

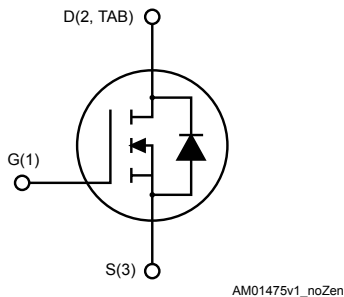

THE DATASHEET OF STF31N65M5

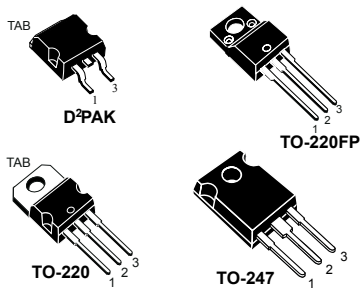

N-channel 650 V, 0.124 Ω , 22 A, MDmesh M5 Power MOSFETs in D²PAK, TO-220FP, TO-220 and TO-247 packages



Features

| Order code | $V_{DS} @ T_{JMAX}$ | $R_{DS(on)}$ max. | I_D | Package |
|------------|---------------------|-------------------|-------|--------------------|
| STB31N65M5 | 710 V | 0.148 Ω | 22 A | D ² PAK |
| STF31N65M5 | | | | TO-220FP |
| STP31N65M5 | | | | TO-220 |
| STW31N65M5 | | | | TO-247 |

- Extremely low $R_{DS(on)}$
- Low gate charge and input capacitance
- Excellent switching performance
- 100% avalanche tested

Applications

- Switching applications

Description

These devices are N-channel Power MOSFETs based on the MDmesh M5 innovative vertical process technology combined with the well-known PowerMESH horizontal layout. The resulting products offer extremely low on-resistance, making them particularly suitable for applications requiring high power and superior efficiency.



Product status link

[STB31N65M5](#)

[STF31N65M5](#)

[STP31N65M5](#)

[STW31N65M5](#)

1 Electrical ratings

Table 1. Absolute maximum ratings

| Symbol | Parameter | Value | | Unit |
|--------------------------------|---|---------------------------------------|---------------------|------|
| | | D ² PAK, TO-220, TO-247 | TO-220FP | |
| V _{GS} | Gate-source voltage | ±25 | | V |
| I _D | Drain current (continuous) at T _C = 25 °C | 22 | 22 ⁽¹⁾ | A |
| I _D | Drain current (continuous) at T _C = 100 °C | 13.9 | 13.9 ⁽¹⁾ | A |
| I _{DM} ⁽²⁾ | Drain current (pulsed) | 88 | 88 ⁽¹⁾ | A |
| P _{TOT} | Total power dissipation at T _C = 25 °C | 150 | 30 | W |
| V _{ISO} | Insulation withstand voltage (RMS) from all three leads to external heat-sink (t = 1 s, T _C = 25 °C) | | 2500 | V |
| dv/dt ⁽³⁾ | Peak diode recovery voltage slope | 15 | | V/ns |
| dv/dt ⁽⁴⁾ | MOSFET dv/dt ruggedness | 50 | | |
| T _J | Operating junction temperature range | -55 to 150 | | °C |
| T _{stg} | Storage temperature range | | | |

1. Limited by package.
2. Limited by maximum junction temperature.
3. I_{SD} ≤ 22 A, di/dt ≤ 400 A/μs; V_{DS} (peak) < V_{(BR)DSS}; V_{DD} = 400 V.
4. V_{DS} ≤ 480 V.

Table 2. Thermal data

| Symbol | Parameter | Value | | | | Unit |
|-------------------------------------|-------------------------------------|--------------------|--------|----------|--------|------|
| | | D ² PAK | TO-220 | TO-220FP | TO-247 | |
| R _{thj-case} | Thermal resistance junction-case | 0.83 | | 4.17 | 0.83 | °C/W |
| R _{thj-amb} | Thermal resistance junction-ambient | | 62.5 | | 50 | °C/W |
| R _{thj-pcb} ⁽¹⁾ | Thermal resistance junction-pcb | 30 | | | | °C/W |

1. When mounted on FR-4 board of 1 inch², 2 oz Cu.

Table 3. Avalanche characteristics

| Symbol | Parameter | Value | Unit |
|----------|--|-------|------|
| I_{AR} | Avalanche current, repetitive or not repetitive (pulse width limited by T_{jmax}) | 5 | A |
| E_{AS} | Single pulse avalanche energy (starting $T_j = 25\text{ °C}$, $I_D = I_{AR}$, $V_{DD} = 50\text{ V}$) | 410 | mJ |

2 Electrical characteristics

$T_C = 25\text{ }^\circ\text{C}$ unless otherwise specified

Table 4. On/off-state

| Symbol | Parameter | Test conditions | Min. | Typ. | Max. | Unit |
|---------------|-----------------------------------|---|------|-------|-----------|---------------|
| $V_{(BR)DSS}$ | Drain-source breakdown voltage | $V_{GS} = 0\text{ V}, I_D = 1\text{ mA}$ | 650 | | | V |
| I_{DSS} | Zero gate voltage drain current | $V_{GS} = 0\text{ V}, V_{DS} = 650\text{ V}$ | | | 1 | μA |
| | | $V_{GS} = 0\text{ V}, V_{DS} = 650\text{ V},$ $T_C = 125\text{ }^\circ\text{C}$ ⁽¹⁾ | | | 100 | μA |
| I_{GSS} | Gate body leakage current | $V_{DS} = 0\text{ V}, V_{GS} = \pm 25\text{ V}$ | | | ± 100 | nA |
| $V_{GS(th)}$ | Gate threshold voltage | $V_{DS} = V_{GS}, I_D = 250\text{ }\mu\text{A}$ | 3 | 4 | 5 | V |
| $R_{DS(on)}$ | Static drain-source on-resistance | $V_{GS} = 10\text{ V}, I_D = 11\text{ A}$ | | 0.124 | 0.148 | Ω |

1. Defined by design, not subject to production test.

Table 5. Dynamic

| Symbol | Parameter | Test conditions | Min. | Typ. | Max. | Unit |
|----------------------------|---------------------------------------|---|------|------|------|----------|
| C_{iss} | Input capacitance | $V_{DS} = 100\text{ V}, f = 1\text{ MHz},$ $V_{GS} = 0\text{ V}$ | - | 1865 | - | pF |
| C_{oss} | Output capacitance | | - | 45 | - | pF |
| C_{rss} | Reverse transfer capacitance | | - | 4.2 | - | pF |
| $C_{o(tr)}$ ⁽¹⁾ | Equivalent capacitance time related | $V_{GS} = 0\text{ V},$ | - | 146 | - | pF |
| $C_{o(er)}$ ⁽²⁾ | Equivalent capacitance energy related | $V_{DS} = 0\text{ to }520\text{ V}$ | - | 43 | - | pF |
| R_g | Intrinsic gate resistance | $f = 1\text{ MHz}$ | - | 2.8 | - | Ω |
| Q_g | Total gate charge | $V_{DD} = 520\text{ V}, I_D = 11\text{ A}$ | - | 45 | - | nC |
| Q_{gs} | Gate-source charge | $V_{GS} = 0\text{ to }10\text{ V}$ | - | 11.5 | - | nC |
| Q_{gd} | Gate-drain charge | (see Figure 18. Test circuit for gate charge behavior) | - | 20 | - | nC |

- $C_{o(tr)}$ is defined as a constant equivalent capacitance giving the same charging time as C_{oss} when V_{DS} increases from 0 to 80% V_{DSS} .
- $C_{o(er)}$ is defined as a constant equivalent capacitance giving the same stored energy as C_{oss} when V_{DS} increases from 0 to 80% V_{DSS} .

Table 6. Switching times

| Symbol | Parameter | Test conditions | Min. | Typ. | Max. | Unit |
|--------------|--------------------|--|------|------|------|------|
| $t_{d(v)}$ | Voltage delay time | $V_{DD} = 400\text{ V}$, $I_D = 14\text{ A}$, | - | 46 | - | ns |
| $t_{r(v)}$ | Voltage rise time | $R_G = 4.7\ \Omega$ | - | 8 | - | ns |
| $t_{f(i)}$ | Current fall time | $V_{GS} = 10\text{ V}$ | - | 8.5 | - | ns |
| $t_{c(off)}$ | Crossing time | (see Figure 19. Test circuit for inductive load switching and diode recovery times and Figure 22. Switching time waveform) | - | 11 | - | ns |

Table 7. Source-drain diode

| Symbol | Parameter | Test conditions | Min. | Typ. | Max. | Unit |
|-----------------|-------------------------------|---|------|------|------|---------------|
| I_{SD} | Source-drain current | | - | | 22 | A |
| $I_{SDM}^{(1)}$ | Source-drain current (pulsed) | | - | | 88 | A |
| $V_{SD}^{(2)}$ | Forward on voltage | $I_{SD} = 22\text{ A}$, $V_{GS} = 0\text{ V}$ | - | | 1.5 | V |
| t_{rr} | Reverse recovery time | $I_{SD} = 22\text{ A}$, $di/dt = 100\text{ A}/\mu\text{s}$, $V_{DD} = 100\text{ V}$ (see Figure 19. Test circuit for inductive load switching and diode recovery times) | - | 336 | | ns |
| Q_{rr} | Reverse recovery charge | | - | 5 | | μC |
| I_{RRM} | Reverse recovery current | | - | 30 | | A |
| t_{rr} | Reverse recovery time | $I_{SD} = 22\text{ A}$, $di/dt = 100\text{ A}/\mu\text{s}$, | - | 406 | | ns |
| Q_{rr} | Reverse recovery charge | $V_{DD} = 100\text{ V}$, $T_J = 150\text{ }^\circ\text{C}$ (see Figure 19. Test circuit for inductive load switching and diode recovery times) | - | 6 | | μC |
| I_{RRM} | Reverse recovery current | | - | 31 | | A |

1. Pulse width limited by safe operating area

2. Pulsed: pulse duration = 300 μs , duty cycle 1.5%

2.1 Electrical characteristics (curves)

Figure 1. Safe operating area for D²PAK, TO-220 and TO-247

Figure 2. Thermal impedance for D²PAK, TO-220 and TO-247

Figure 3. Safe operating area for TO-220FP

Figure 4. Thermal impedance for TO-220FP

Figure 5. Output characteristics

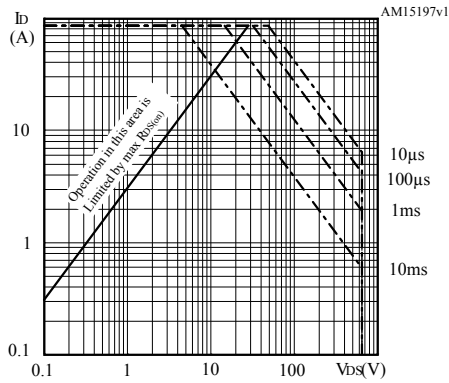
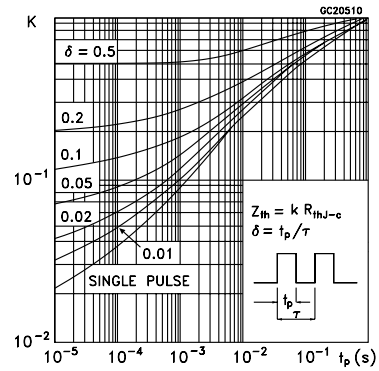
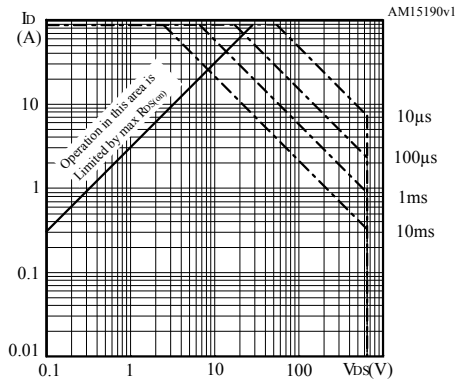
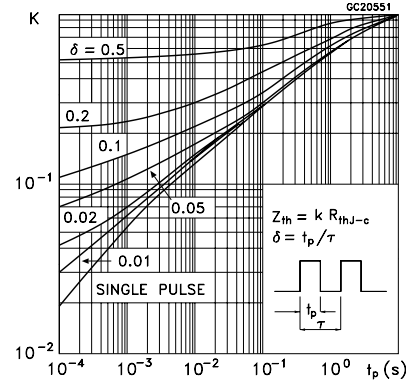
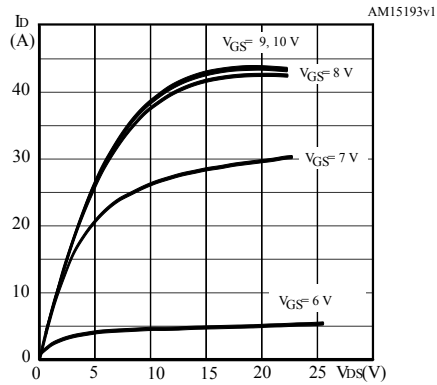
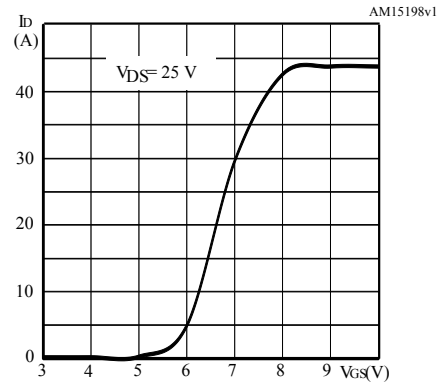
Figure 6. Transfer characteristics

Figure 7. Gate charge vs gate-source voltage

Figure 8. Static drain-source on-resistance

Figure 9. Capacitance variations

Figure 10. Output capacitance stored energy

Figure 11. Normalized gate threshold voltage vs temperature

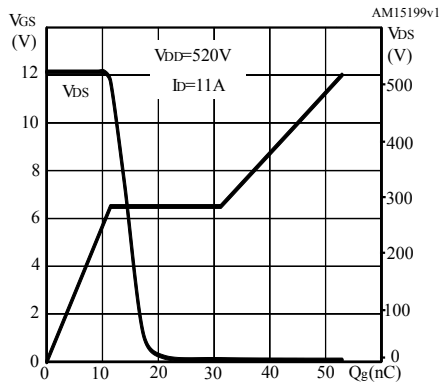
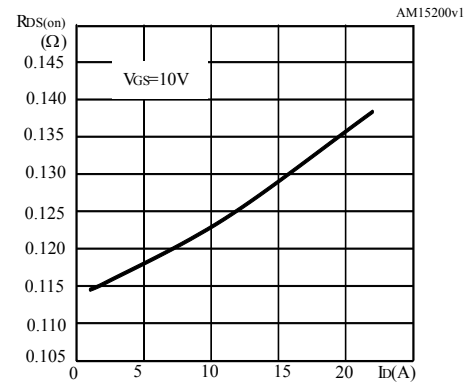
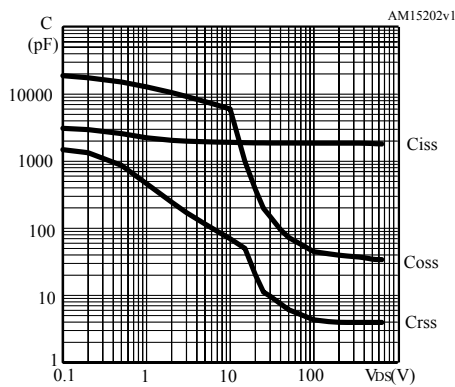
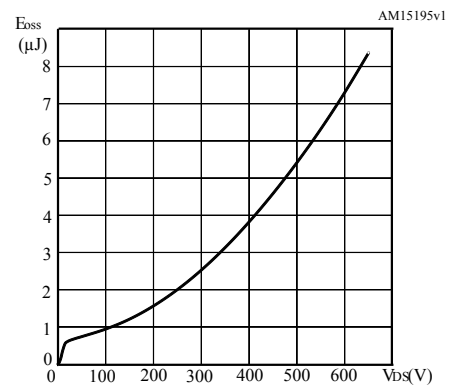
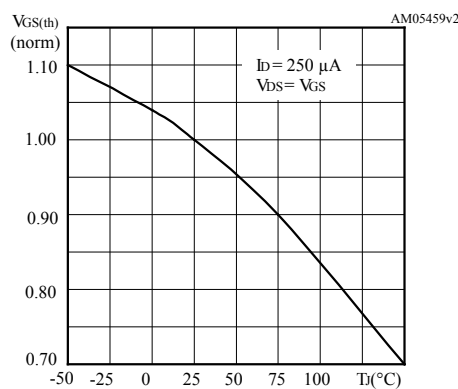
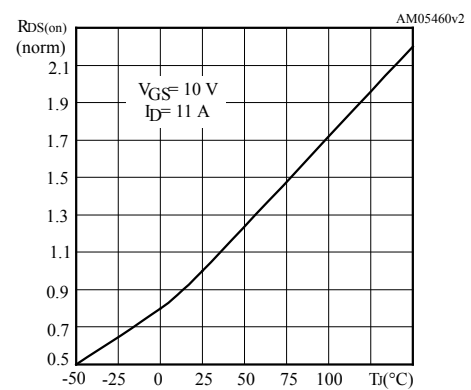
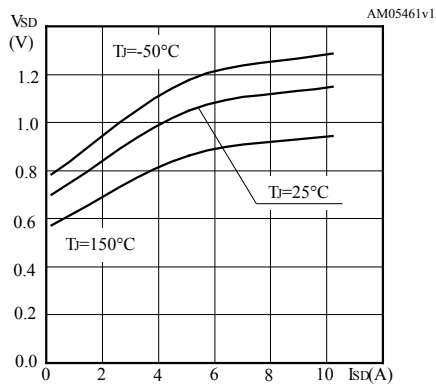
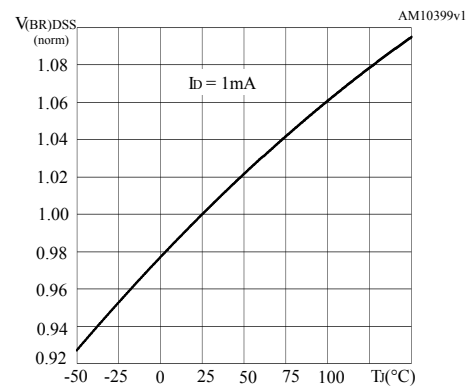
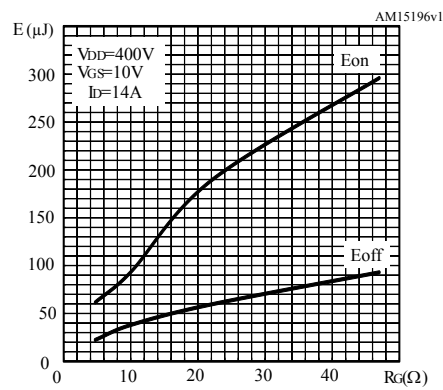
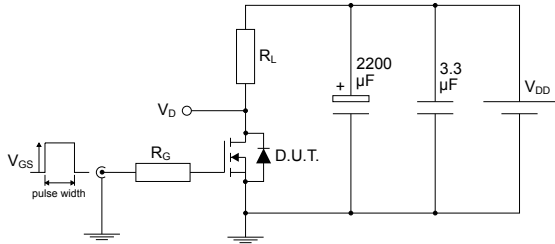
Figure 12. Normalized on-resistance vs temperature

Figure 13. Source-drain diode forward characteristics

Figure 14. Normalized $V_{(BR)DSS}$ vs temperature

Figure 15. Switching energy vs gate resistance

Note: E_{on} including reverse recovery of a SiC diode.

3 Test circuits

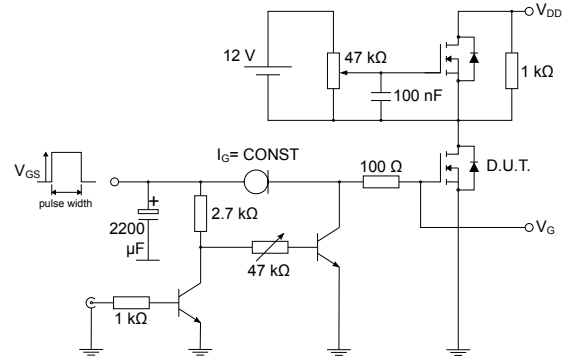
Figure 17. Test circuit for resistive load switching times

AM01468v1

Figure 18. Test circuit for gate charge behavior

AM01469v1

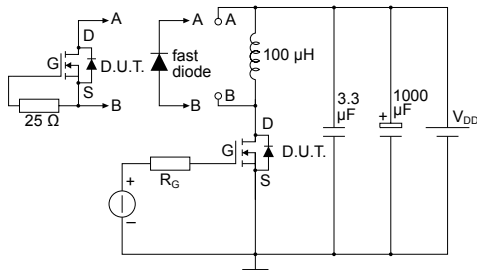
Figure 19. Test circuit for inductive load switching and diode recovery times

AM01470v1

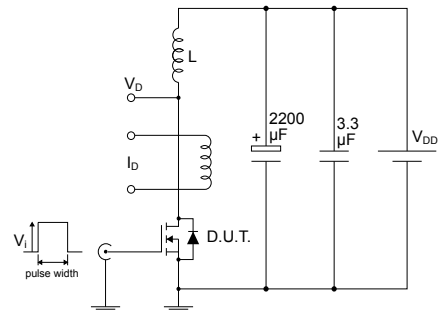
Figure 20. Unclamped inductive load test circuit

AM01471v1

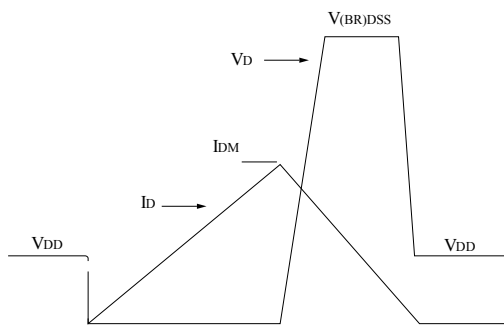
Figure 21. Unclamped inductive waveform

AM01472v1

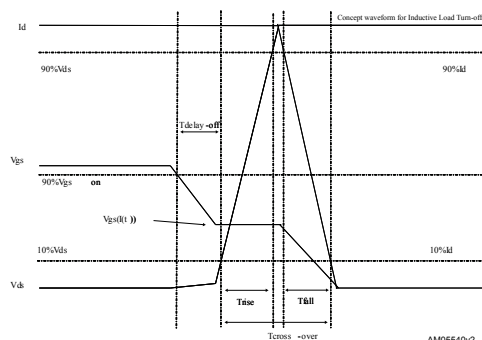
Figure 22. Switching time waveform

AM05540v2

4 Package information

In order to meet environmental requirements, ST offers these devices in different grades of **ECOPACK** packages, depending on their level of environmental compliance. ECOPACK specifications, grade definitions and product status are available at: www.st.com. ECOPACK is an ST trademark.

4.1 D²PAK (TO-263) package information

Figure 23. D²PAK (TO-263) type A package outline

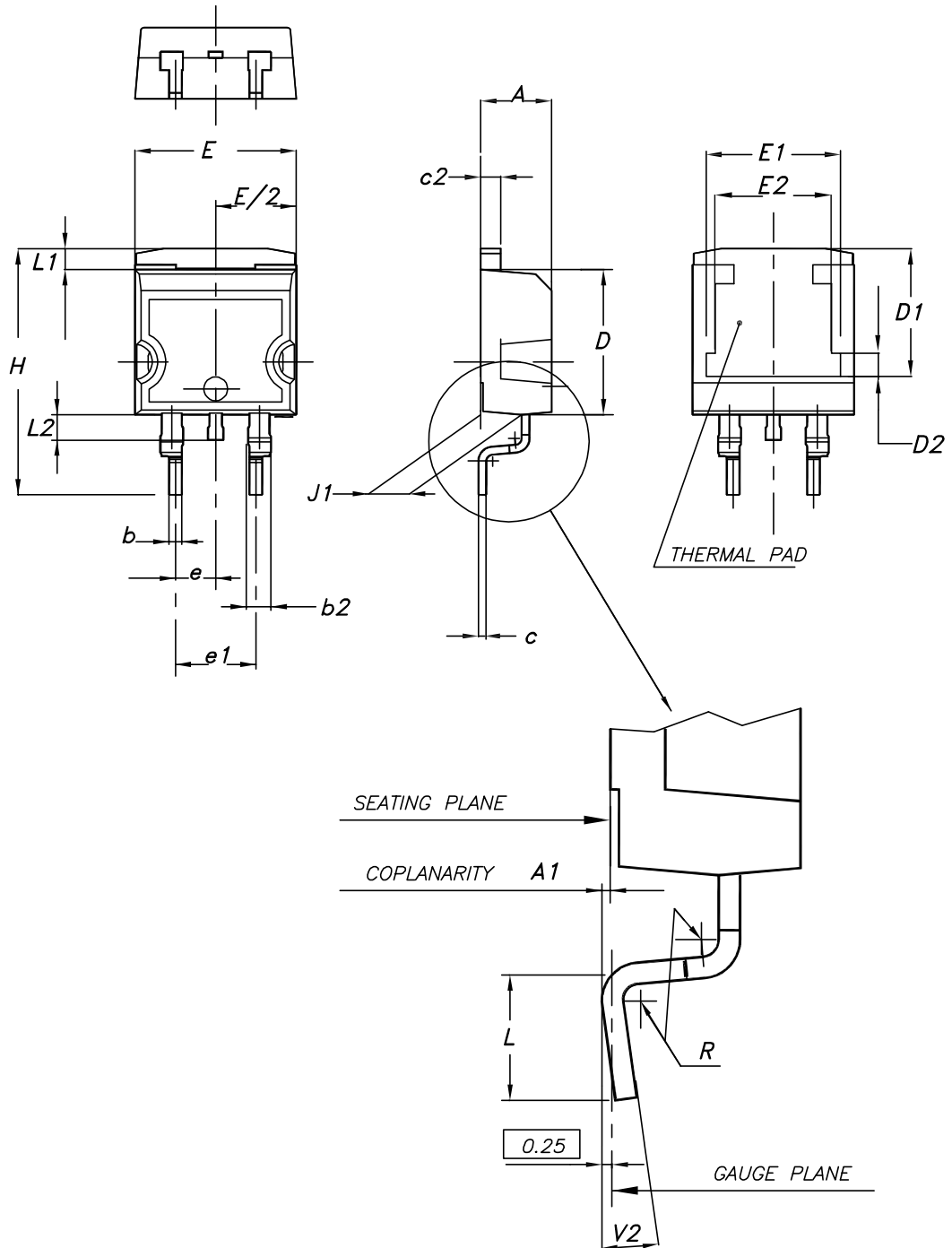

0079457_25

Table 8. D²PAK (TO-263) type A package mechanical data

| Dim. | mm | | |
|------|-------|------|-------|
| | Min. | Typ. | Max. |
| A | 4.40 | | 4.60 |
| A1 | 0.03 | | 0.23 |
| b | 0.70 | | 0.93 |
| b2 | 1.14 | | 1.70 |
| c | 0.45 | | 0.60 |
| c2 | 1.23 | | 1.36 |
| D | 8.95 | | 9.35 |
| D1 | 7.50 | 7.75 | 8.00 |
| D2 | 1.10 | 1.30 | 1.50 |
| E | 10.00 | | 10.40 |
| E1 | 8.30 | 8.50 | 8.70 |
| E2 | 6.85 | 7.05 | 7.25 |
| e | | 2.54 | |
| e1 | 4.88 | | 5.28 |
| H | 15.00 | | 15.85 |
| J1 | 2.49 | | 2.69 |
| L | 2.29 | | 2.79 |
| L1 | 1.27 | | 1.40 |
| L2 | 1.30 | | 1.75 |
| R | | 0.40 | |
| V2 | 0° | | 8° |

Figure 24. D²PAK (TO-263) type B package outline

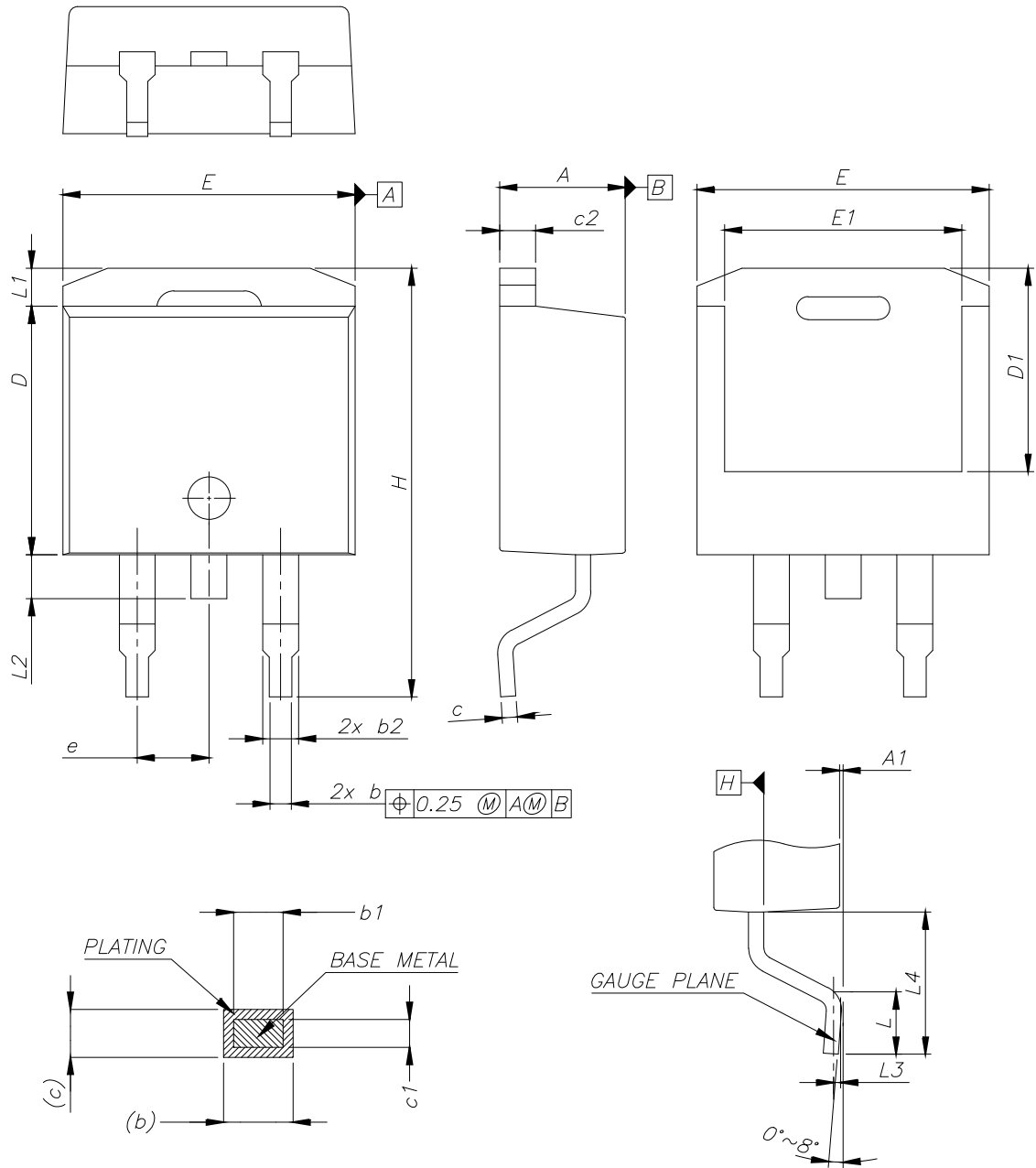

0079457_26_B

Table 9. D²PAK (TO-263) type B mechanical data

| Dim. | mm | | |
|------|----------|------|-------|
| | Min. | Typ. | Max. |
| A | 4.36 | | 4.56 |
| A1 | 0 | | 0.25 |
| b | 0.70 | | 0.90 |
| b1 | 0.51 | | 0.89 |
| b2 | 1.17 | | 1.37 |
| c | 0.38 | | 0.694 |
| c1 | 0.38 | | 0.534 |
| c2 | 1.19 | | 1.34 |
| D | 8.60 | | 9.00 |
| D1 | 6.90 | | 7.50 |
| E | 10.15 | | 10.55 |
| E1 | 8.10 | | 8.70 |
| e | 2.54 BSC | | |
| H | 15.00 | | 15.60 |
| L | 1.90 | | 2.50 |
| L1 | | | 1.65 |
| L2 | | | 1.78 |
| L3 | | 0.25 | |
| L4 | 4.78 | | 5.28 |

Figure 25. D²PAK (TO-263) recommended footprint (dimensions are in mm)

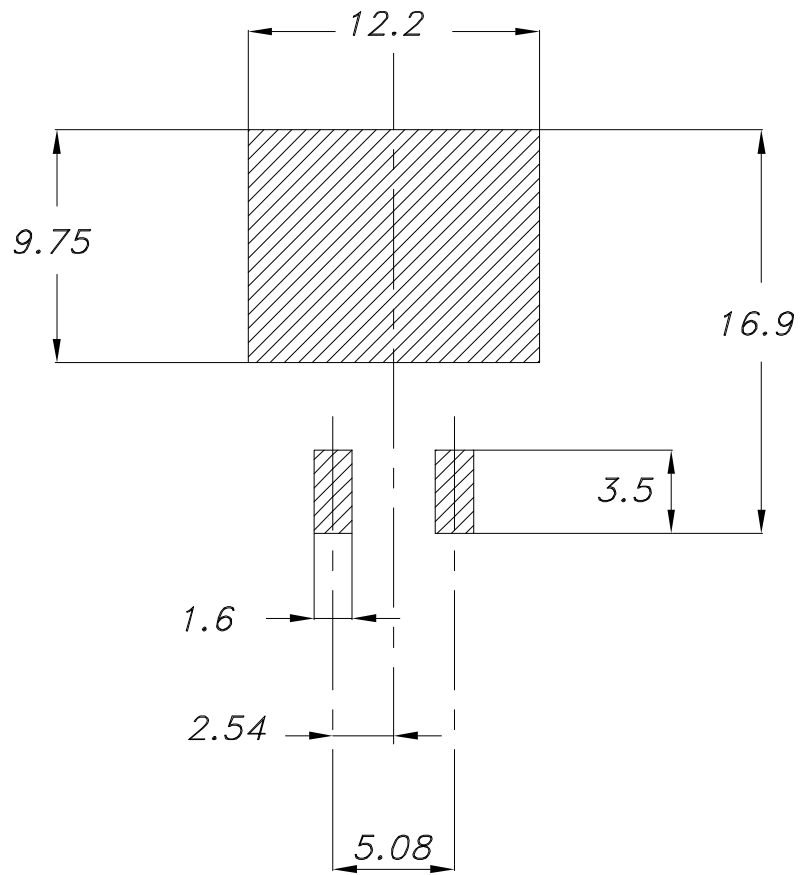

Footprint

4.2 D²PAK packing information

Figure 26. D²PAK tape outline

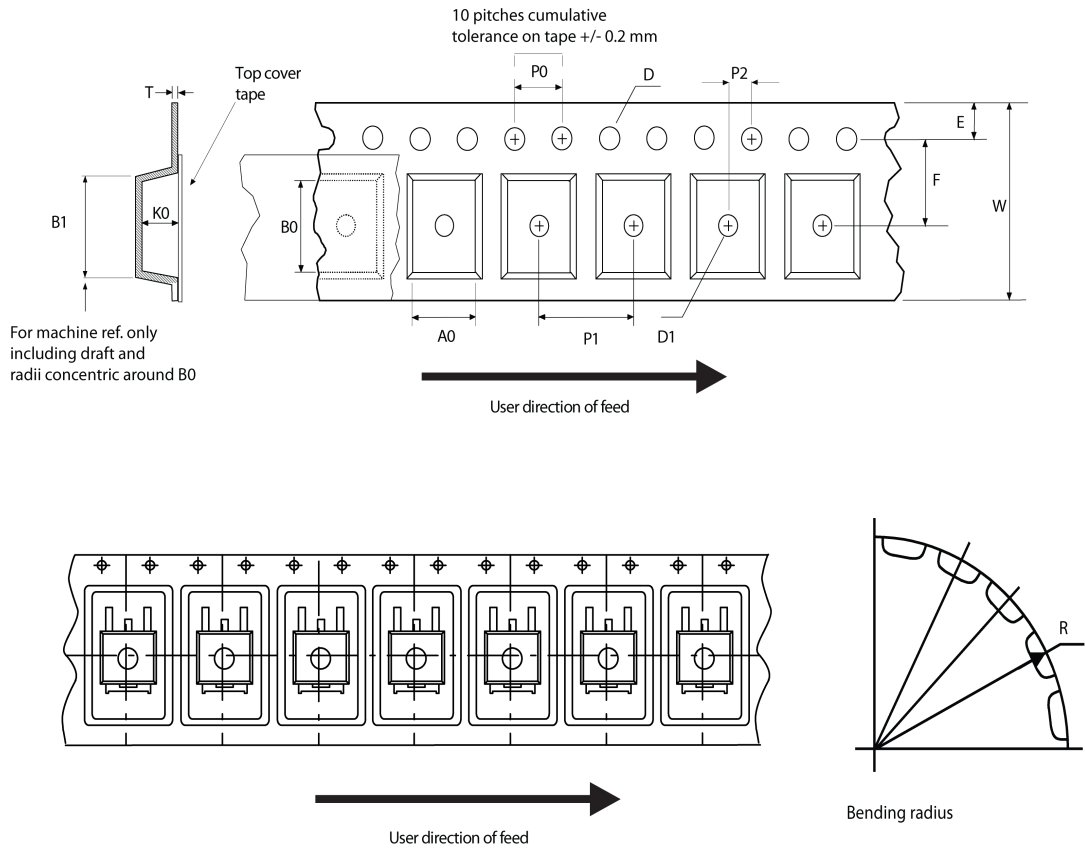

AM08852v1

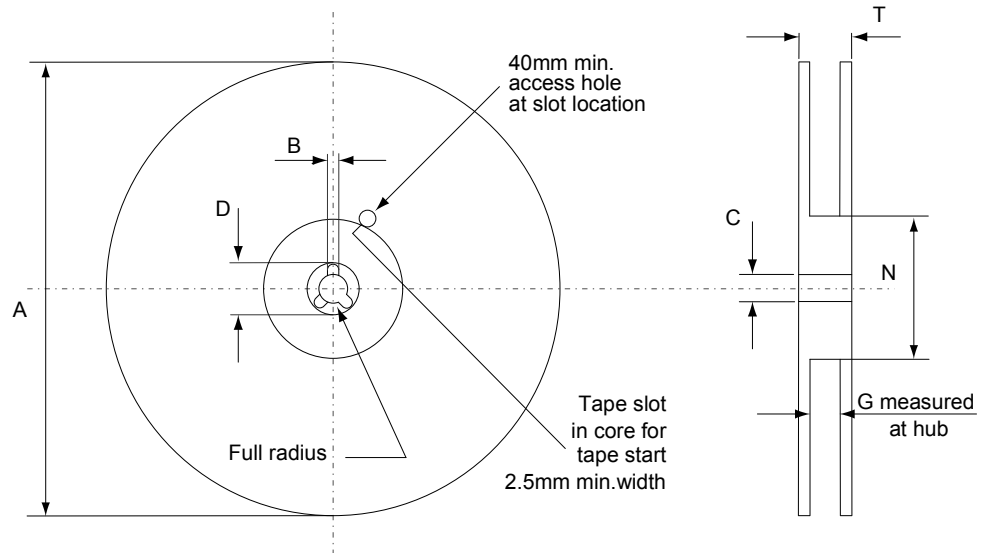
Figure 27. D²PAK reel outline

AM06038v1

Table 10. D²PAK tape and reel mechanical data

| Tape | | | Reel | | | |
|------|------|------|--------------------------------|------|------|------|
| Dim. | mm | | Dim. | mm | | |
| | Min. | Max. | | Min. | Max. | |
| A0 | 10.5 | 10.7 | A | | 330 | |
| B0 | 15.7 | 15.9 | B | 1.5 | | |
| D | 1.5 | 1.6 | C | 12.8 | 13.2 | |
| D1 | 1.59 | 1.61 | D | 20.2 | | |
| E | 1.65 | 1.85 | G | 24.4 | 26.4 | |
| F | 11.4 | 11.6 | N | 100 | | |
| K0 | 4.8 | 5.0 | T | | 30.4 | |
| P0 | 3.9 | 4.1 | Base quantity Bulk quantity | | | |
| P1 | 11.9 | 12.1 | | | | 1000 |
| P2 | 1.9 | 2.1 | | | | 1000 |
| R | 50 | | | | | |
| T | 0.25 | 0.35 | | | | |
| W | 23.7 | 24.3 | | | | |

4.3 D²PAK type B packing information

Figure 28. D²PAK type B tape outline

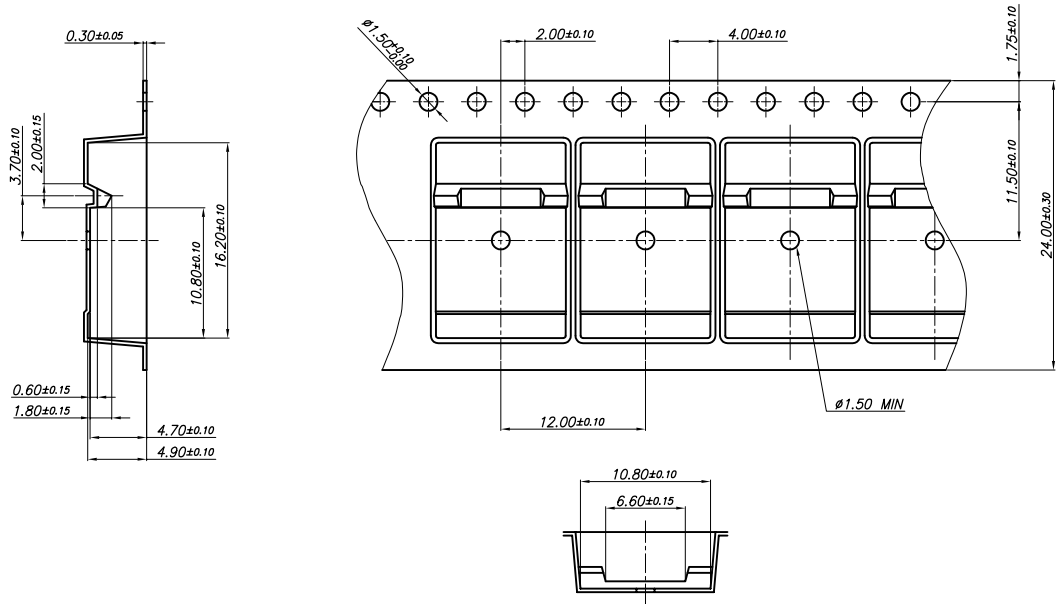
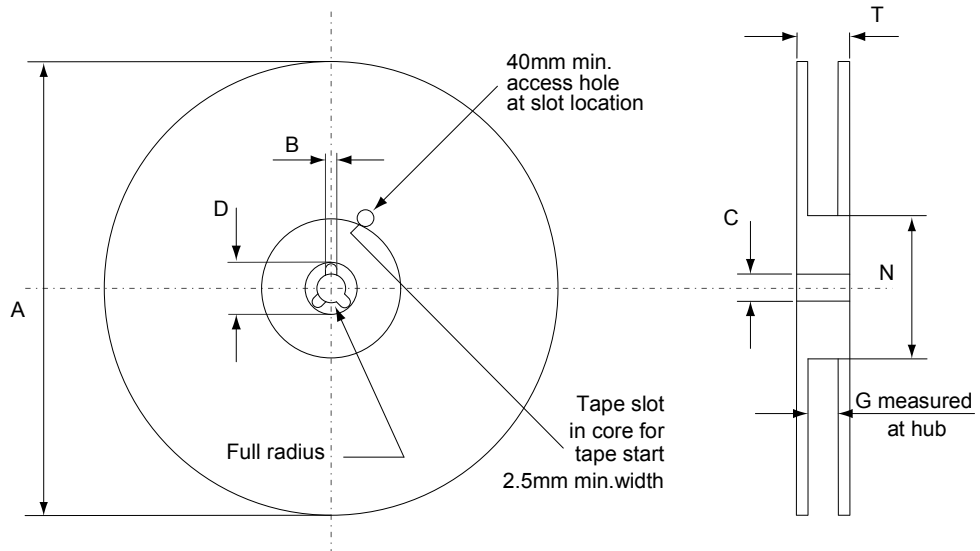

Figure 29. D²PAK type B reel outline



AM06038v1

Table 11. D²PAK type B reel mechanical data

| Dim. | mm | |
|------|------|------|
| | Min. | Max. |
| A | | 330 |
| B | 1.5 | |
| C | 12.8 | 13.2 |
| D | 20.2 | |
| G | 24.4 | 26.4 |
| N | 100 | |
| T | | 30.4 |

4.4 TO-220FP package information

Figure 30. TO-220FP package outline

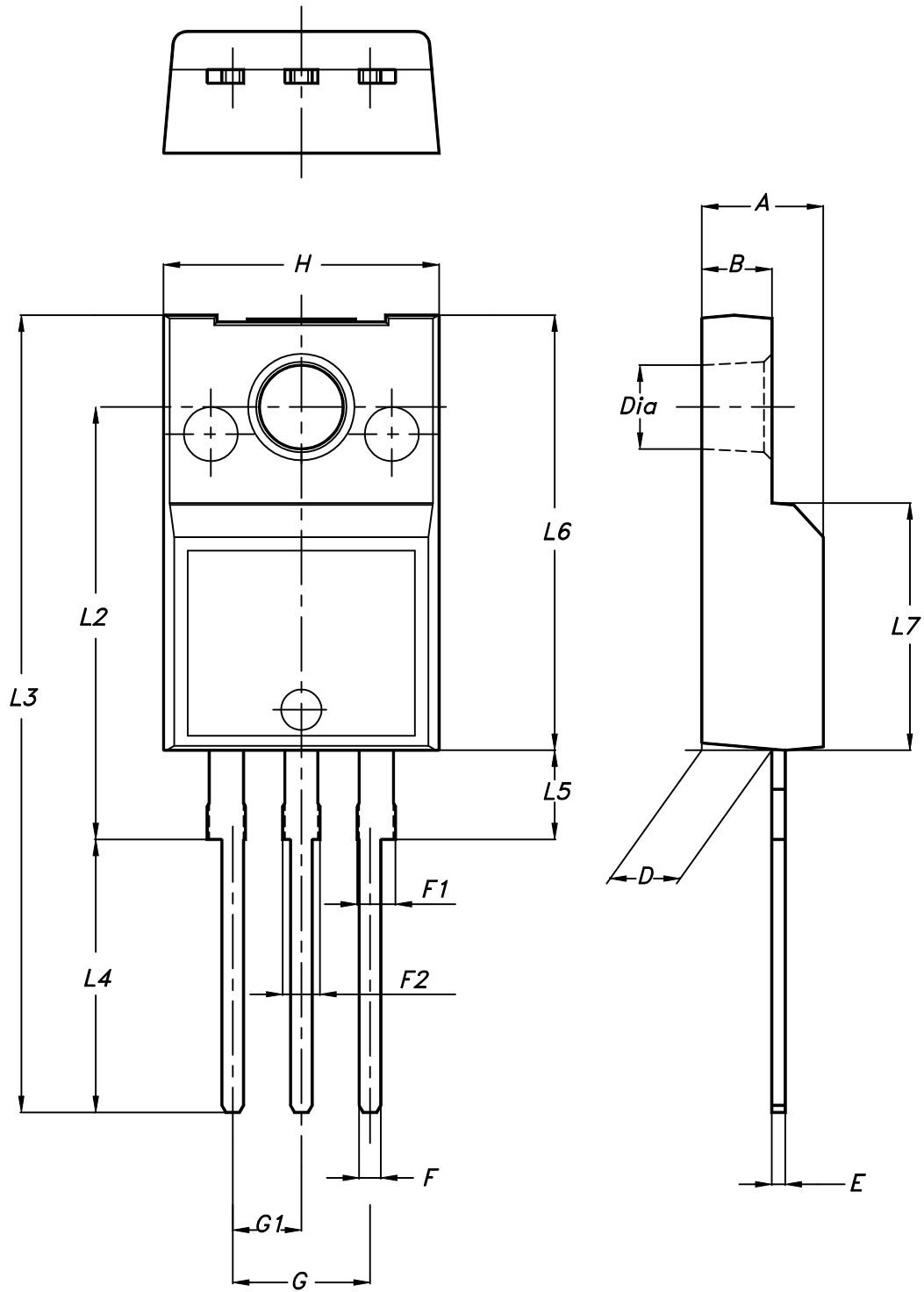

7012510_Rev_12_B

Table 12. TO-220FP package mechanical data

| Dim. | mm | | |
|------|------|------|------|
| | Min. | Typ. | Max. |
| A | 4.4 | | 4.6 |
| B | 2.5 | | 2.7 |
| D | 2.5 | | 2.75 |
| E | 0.45 | | 0.7 |
| F | 0.75 | | 1 |
| F1 | 1.15 | | 1.70 |
| F2 | 1.15 | | 1.70 |
| G | 4.95 | | 5.2 |
| G1 | 2.4 | | 2.7 |
| H | 10 | | 10.4 |
| L2 | | 16 | |
| L3 | 28.6 | | 30.6 |
| L4 | 9.8 | | 10.6 |
| L5 | 2.9 | | 3.6 |
| L6 | 15.9 | | 16.4 |
| L7 | 9 | | 9.3 |
| Dia | 3 | | 3.2 |

4.5 TO-220 type A package information

Figure 31. TO-220 type A package outline

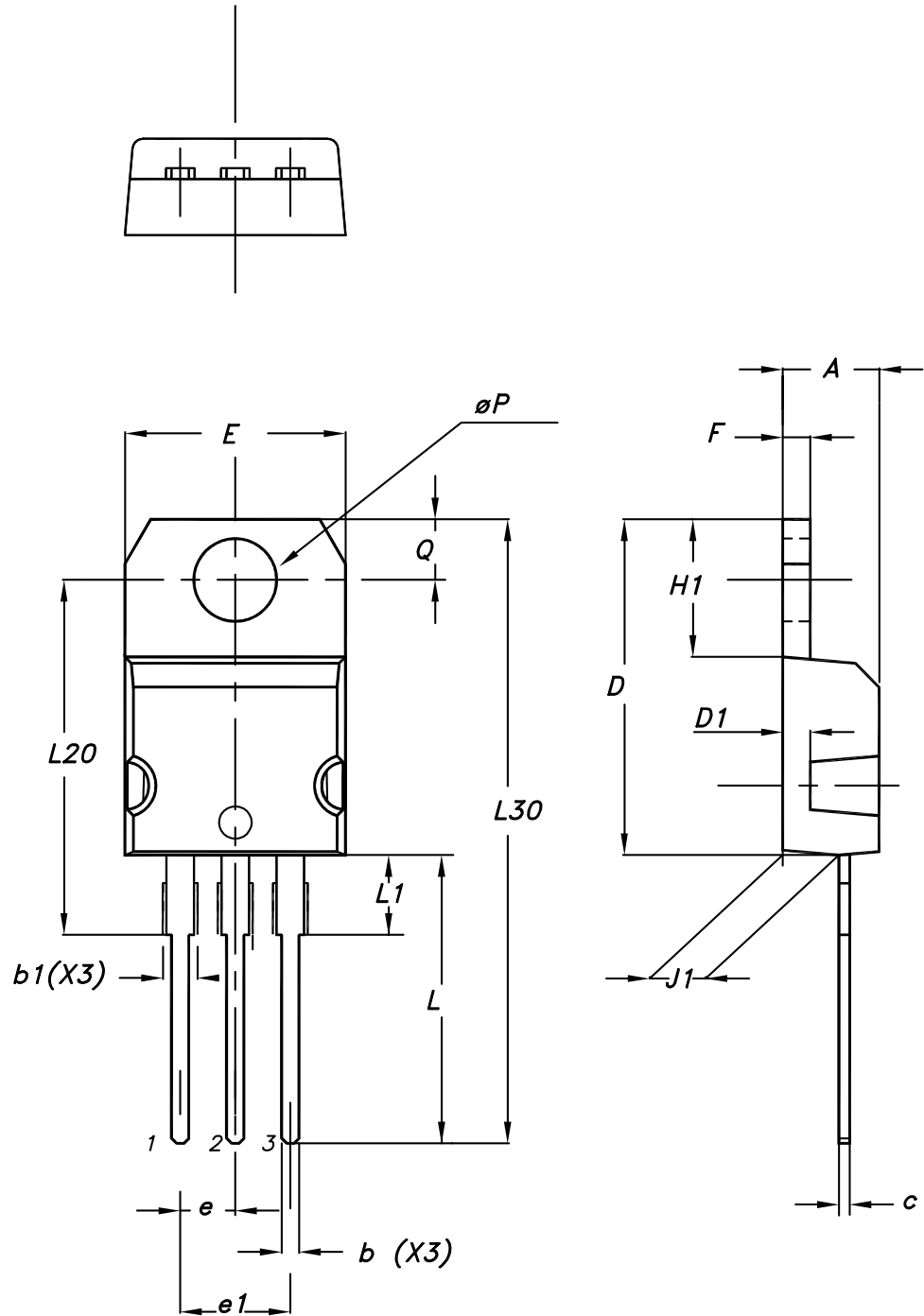

0015988_typeA_Rev_22

Table 13. TO-220 type A package mechanical data

| Dim. | mm | | |
|------|-------|-------|-------|
| | Min. | Typ. | Max. |
| A | 4.40 | | 4.60 |
| b | 0.61 | | 0.88 |
| b1 | 1.14 | | 1.55 |
| c | 0.48 | | 0.70 |
| D | 15.25 | | 15.75 |
| D1 | | 1.27 | |
| E | 10.00 | | 10.40 |
| e | 2.40 | | 2.70 |
| e1 | 4.95 | | 5.15 |
| F | 1.23 | | 1.32 |
| H1 | 6.20 | | 6.60 |
| J1 | 2.40 | | 2.72 |
| L | 13.00 | | 14.00 |
| L1 | 3.50 | | 3.93 |
| L20 | | 16.40 | |
| L30 | | 28.90 | |
| øP | 3.75 | | 3.85 |
| Q | 2.65 | | 2.95 |

4.6 TO-247 package information

Figure 32. TO-247 package outline

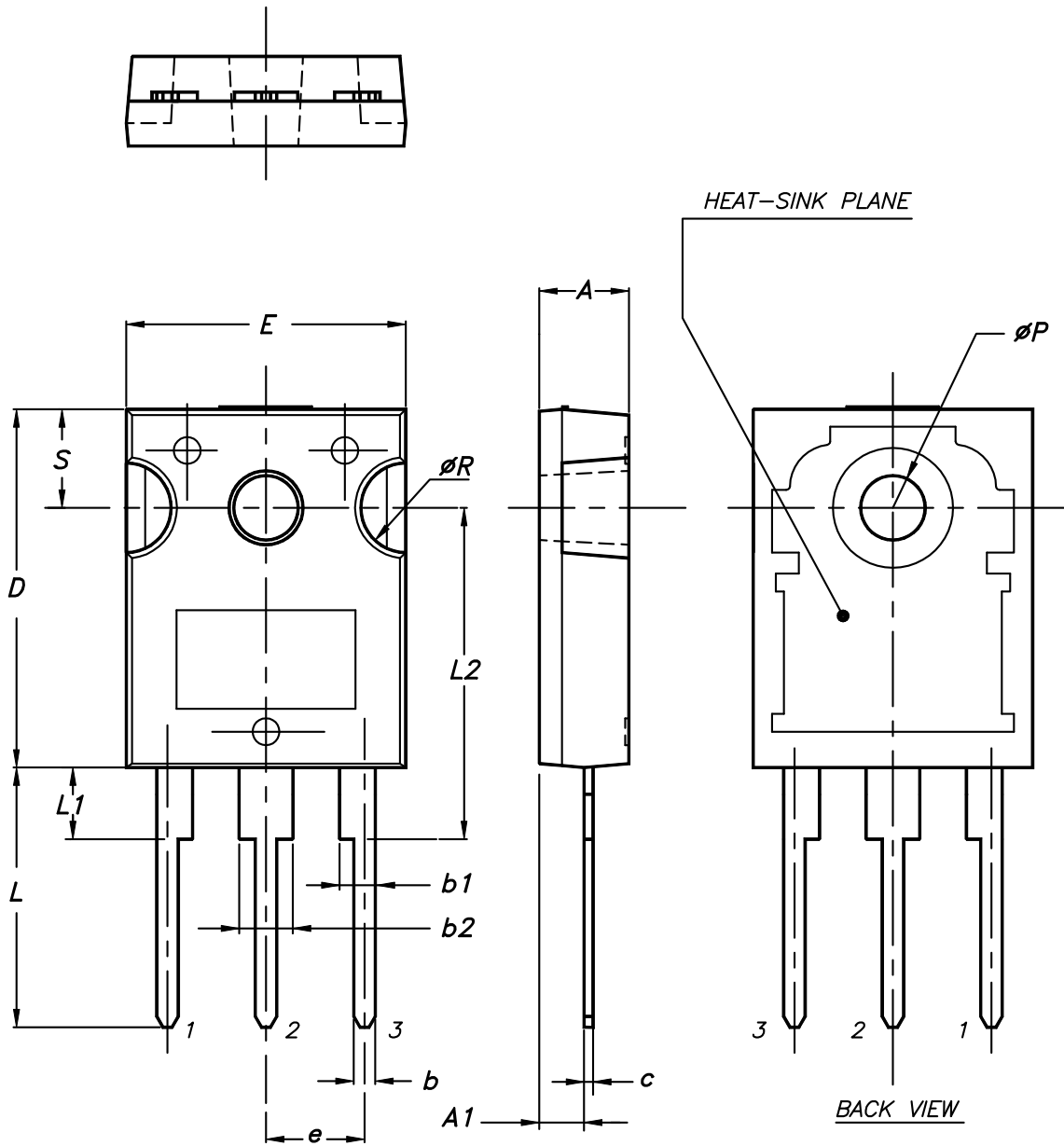

0075325_9

Table 14. TO-247 package mechanical data

| Dim. | mm | | |
|------|-------|-------|-------|
| | Min. | Typ. | Max. |
| A | 4.85 | | 5.15 |
| A1 | 2.20 | | 2.60 |
| b | 1.0 | | 1.40 |
| b1 | 2.0 | | 2.40 |
| b2 | 3.0 | | 3.40 |
| c | 0.40 | | 0.80 |
| D | 19.85 | | 20.15 |
| E | 15.45 | | 15.75 |
| e | 5.30 | 5.45 | 5.60 |
| L | 14.20 | | 14.80 |
| L1 | 3.70 | | 4.30 |
| L2 | | 18.50 | |
| ØP | 3.55 | | 3.65 |
| ØR | 4.50 | | 5.50 |
| S | 5.30 | 5.50 | 5.70 |

5 Ordering information

Table 15. Order codes

| Order code | Marking | Package | Packing |
|------------|---------|--------------------|-------------|
| STB31N65M5 | 31N65M5 | D ² PAK | Tape e reel |
| STF31N65M5 | | TO-220FP | Tube |
| STP31N65M5 | | TO-220 | |
| STW31N65M5 | | TO-247 | |

Revision history

Table 16. Document revision history

| Date | Revision | Changes |
|-------------|----------|--|
| 23-Feb-2012 | 1 | First release. |
| 10-Sep-2012 | 2 | <ul style="list-style-type: none"> – Modified <i>note 2</i> under the <i>Table 2</i>. – Updated typical values in <i>Table 4, 5 and 6</i>. – Added <i>Section 2.1</i>. – Minor text changes on the cover page. |
| 05-Mar-2013 | 3 | Added <i>dv/dt</i> value on <i>Table 2: Absolute maximum ratings</i> . |
| 15-Apr-2019 | 4 | <p>The part number STFI31N65M5 has been moved to a separate datasheet.</p> <p>Removed maturity status indication from cover page. The document status is production data.</p> <p>Updated features and description in cover page.</p> <p>Updated Section 4 Package information.</p> <p>Added Section 5 Ordering information.</p> <p>Minor text changes.</p> |

Contents

| | | |
|------------|---|-----------|
| 1 | Electrical ratings | 2 |
| 2 | Electrical characteristics | 4 |
| 2.1 | Electrical characteristics (curves) | 6 |
| 3 | Test circuits | 9 |
| 4 | Package information | 10 |
| 4.1 | D ² PAK (TO-263) package information | 10 |
| 4.2 | D ² PAK packing information | 15 |
| 4.3 | D ² PAK type B packing information | 18 |
| 4.4 | TO-220FP package information | 19 |
| 4.5 | TO-220 type A package information | 21 |
| 4.6 | TO-247 package information | 23 |
| 5 | Ordering information | 26 |
| | Revision history | 27 |



IMPORTANT NOTICE – PLEASE READ CAREFULLY

STMicroelectronics NV and its subsidiaries (“ST”) reserve the right to make changes, corrections, enhancements, modifications, and improvements to ST products and/or to this document at any time without notice. Purchasers should obtain the latest relevant information on ST products before placing orders. ST products are sold pursuant to ST’s terms and conditions of sale in place at the time of order acknowledgement.

Purchasers are solely responsible for the choice, selection, and use of ST products and ST assumes no liability for application assistance or the design of Purchasers’ products.

No license, express or implied, to any intellectual property right is granted by ST herein.

Resale of ST products with provisions different from the information set forth herein shall void any warranty granted by ST for such product.

ST and the ST logo are trademarks of ST. For additional information about ST trademarks, please refer to www.st.com/trademarks. All other product or service names are the property of their respective owners.

Information in this document supersedes and replaces information previously supplied in any prior versions of this document.

© 2019 STMicroelectronics – All rights reserved

Looking for pricing, stock, or lifecycle information?

Click below to explore more details on WIN SOURCE:

- ⊖ [View STF31N65M5 on WIN SOURCE](#)
- ⊖ [STMicroelectronics Information](#)

Optimize Your Supply Chain with WIN SOURCE Solutions

- ✓ Global Sourcing Solution
- ✓ Obsolete Management
- ✓ Cost Control Management
- ✓ Shortage Management
- ✓ Alternative Solution
- ✓ Excess Inventory Management