



**THE DATASHEET OF
CY7C1440AV33-167BZC**





CY7C1440AV33

CY7C1442AV33

CY7C1446AV33

36-Mbit (1 M × 36/2 M × 18/512 K × 72) Pipelined Sync SRAM

Features

- Supports bus operation up to 250 MHz
- Available speed grades are 250, 200 and 167 MHz
- Registered inputs and outputs for pipelined operation
- 3.3 V core power supply
- 2.5 V/3.3 V I/O power supply
- Fast clock-to-output times
 - 2.6 ns (for 250-MHz device)
- Provide high-performance 3-1-1 access rate
- User-selectable burst counter supporting Intel® Pentium® interleaved or linear burst sequences
- Separate processor and controller address strobes
- Synchronous self-timed writes
- Asynchronous output enable
- Single cycle chip deselect
- CY7C1440AV33, CY7C1442AV33 available in Pb-free 100-pin TQFP package, Pb-free and non Pb-free 165-ball FBGA package. CY7C1446AV33 available in Pb-free and non Pb-free 209-ball FBGA package
- Also available in Pb-free packages
- IEEE 1149.1 JTAG-compatible boundary scan
- “ZZ” sleep mode option

Functional Description^[1]

The CY7C1440AV33/CY7C1442AV33/CY7C1446AV33 SRAM integrates 1 M × 36/2 M × 18 and 512 K × 72 SRAM cells with advanced synchronous peripheral circuitry and a two-bit counter for internal burst operation. All synchronous inputs are gated by registers controlled by a positive-edge-triggered clock input (CLK). The synchronous inputs include all addresses, all data inputs, address-pipelining chip enable (\overline{CE}_1), depth-expansion chip enables (\overline{CE}_2 and \overline{CE}_3), burst control inputs (ADSC, ADSP, and ADV), write enables (\overline{BW}_X and \overline{BWE}), and global write (\overline{GW}). Asynchronous inputs include the output enable (\overline{OE}) and the ZZ pin.

Addresses and chip enables are registered at rising edge of clock when either address strobe processor (ADSP) or address strobe controller (ADSC) are active. Subsequent burst addresses can be internally generated as controlled by the advance pin (ADV).

Address, data inputs, and write controls are registered on-chip to initiate a self-timed write cycle. This part supports byte write operations (see pin descriptions and truth table for further details). Write cycles can be one to two or four bytes wide as controlled by the byte write control inputs. \overline{GW} when active LOW causes all bytes to be written.

The CY7C1440AV33/CY7C1442AV33/CY7C1446AV33 operates from a +3.3 V core power supply while all outputs may operate with either a +2.5 or +3.3 V supply. All inputs and outputs are JEDEC-standard JESD8-5-compatible.

Note

1. For best-practices recommendations, please refer to the Cypress application note *System Design Guidelines* on www.cypress.com.

Logic Block Diagram – CY7C1440AV33 (1 M × 36)

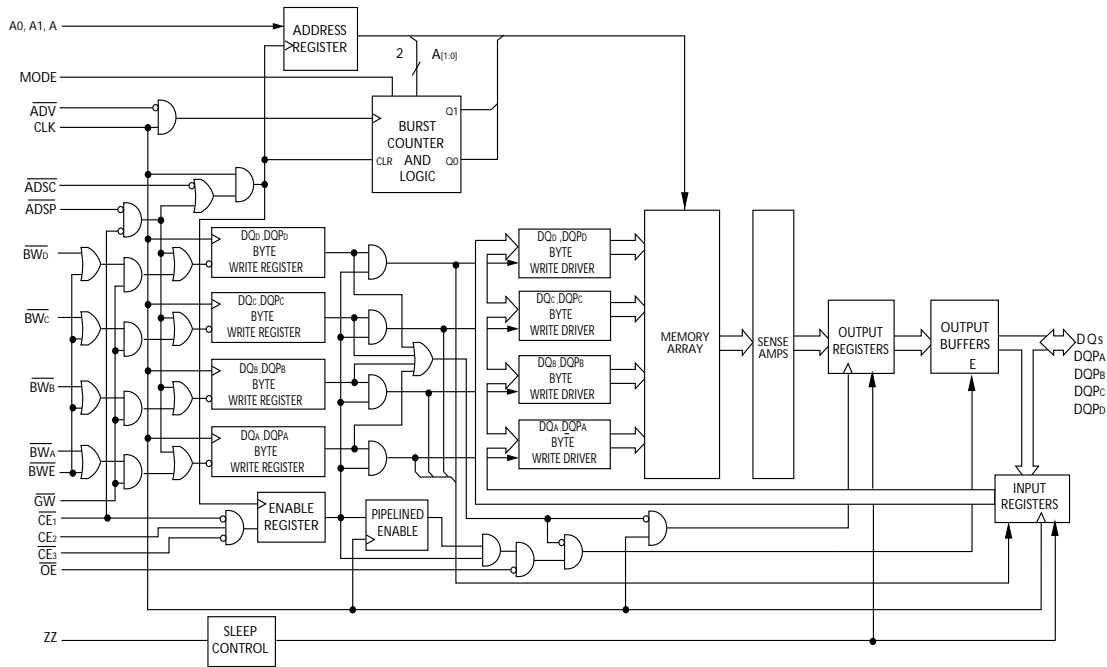

Logic Block Diagram – CY7C1442AV33 (2 M × 18)

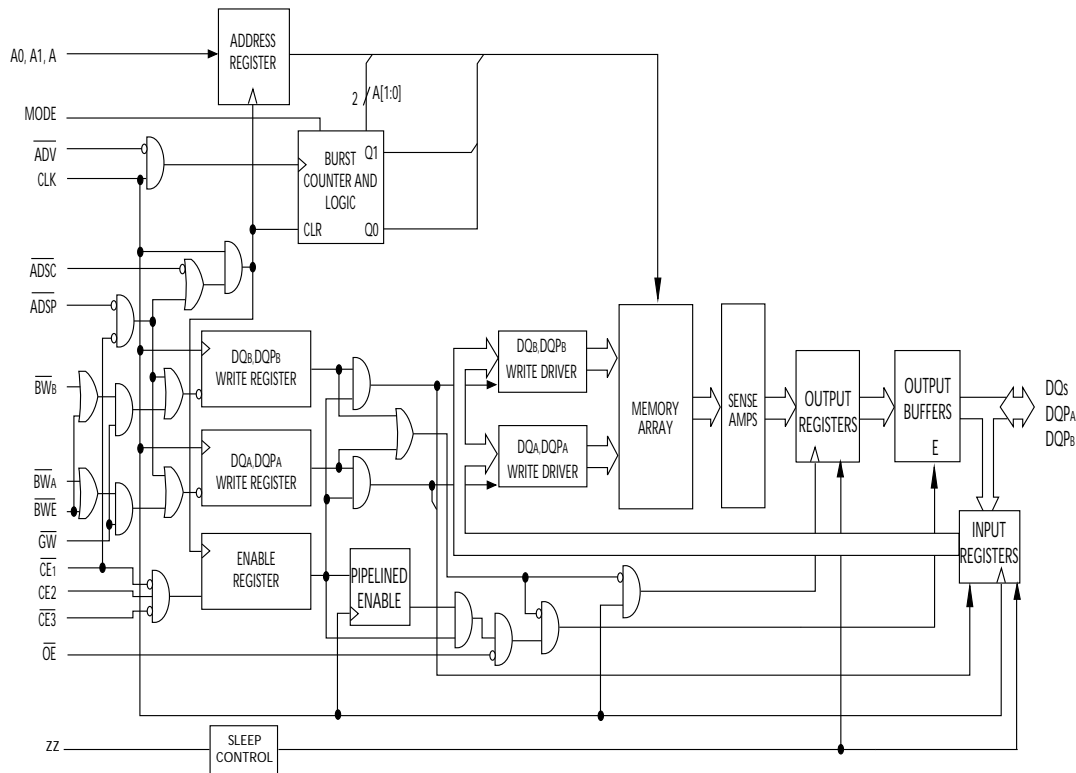

Logic Block Diagram – CY7C1446AV33 (512 K × 72)

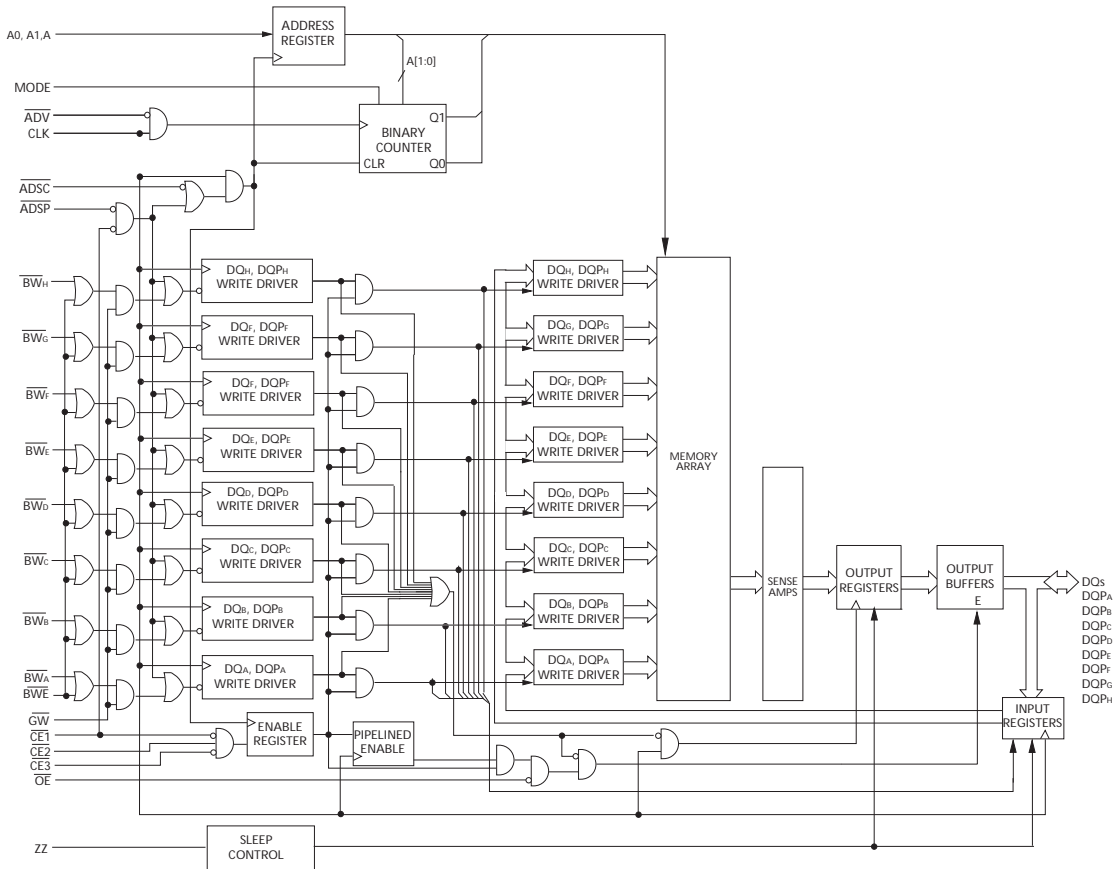

Contents

| | | | |
|--|-----------|--|-----------|
| Selection Guide | 5 | TAP DC Electrical Characteristics and | |
| Pin Configurations | 5 | Operating Conditions | 17 |
| Pin Definitions | 7 | Identification Register Definitions | 17 |
| Functional Overview | 9 | Scan Register Sizes | 17 |
| Single Read Accesses | 9 | Identification Codes | 17 |
| Single Write Accesses Initiated by ADSP | 9 | 165-ball FBGA Boundary Scan Order | 18 |
| Single Write Accesses Initiated by ADSC | 9 | 209-ball FBGA Boundary Scan Order | 19 |
| Burst Sequences | 9 | Maximum Ratings | 20 |
| Sleep Mode | 9 | Operating Range | 20 |
| Interleaved Burst Address Table | | Electrical Characteristics | 20 |
| (MODE = Floating or V_{DD}) | 10 | Capacitance | 21 |
| Linear Burst Address Table (MODE = GND) | 10 | Thermal Resistance | 21 |
| ZZ Mode Electrical Characteristics | 10 | AC Test Loads and Waveforms | 21 |
| Truth Table | 11 | Switching Characteristics | 22 |
| Truth Table for Read/Write | 12 | Switching Waveforms | 23 |
| Truth Table for Read/Write | 12 | Read Cycle Timing | 23 |
| Truth Table for Read/Write | 12 | Write Cycle Timing | 24 |
| IEEE 1149.1 Serial Boundary Scan (JTAG) | 13 | Read/Write Cycle Timing | 25 |
| Disabling the JTAG Feature | 13 | ZZ Mode Timing | 26 |
| TAP Controller State Diagram | 13 | Ordering Information | 27 |
| Test Access Port (TAP) | 13 | Ordering Code Definitions | 27 |
| TAP Controller Block Diagram | 13 | Package Diagrams | 28 |
| PERFORMING A TAP RESET | 13 | Acronyms | 31 |
| TAP REGISTERS | 13 | Document Conventions | 31 |
| TAP Instruction Set | 14 | Units of Measure | 31 |
| TAP Timing | 15 | Document History Page | 32 |
| TAP AC Switching Characteristics | 16 | Sales, Solutions, and Legal Information | 34 |
| 3.3 V TAP AC Test Conditions | 16 | Worldwide Sales and Design Support | 34 |
| 3.3 V TAP AC Output Load Equivalent | 16 | Products | 34 |
| 2.5 V TAP AC Test Conditions | 16 | PSoC Solutions | 34 |
| 2.5 V TAP AC Output Load Equivalent | 16 | | |

Selection Guide

| | 250 MHz | 200 MHz | 167 MHz | Unit |
|------------------------------|---------|---------|---------|------|
| Maximum access time | 2.6 | 3.2 | 3.4 | ns |
| Maximum operating current | 475 | 425 | 375 | mA |
| Maximum CMOS standby current | 120 | 120 | 120 | mA |

Pin Configurations

100-pin TQFP Pinout

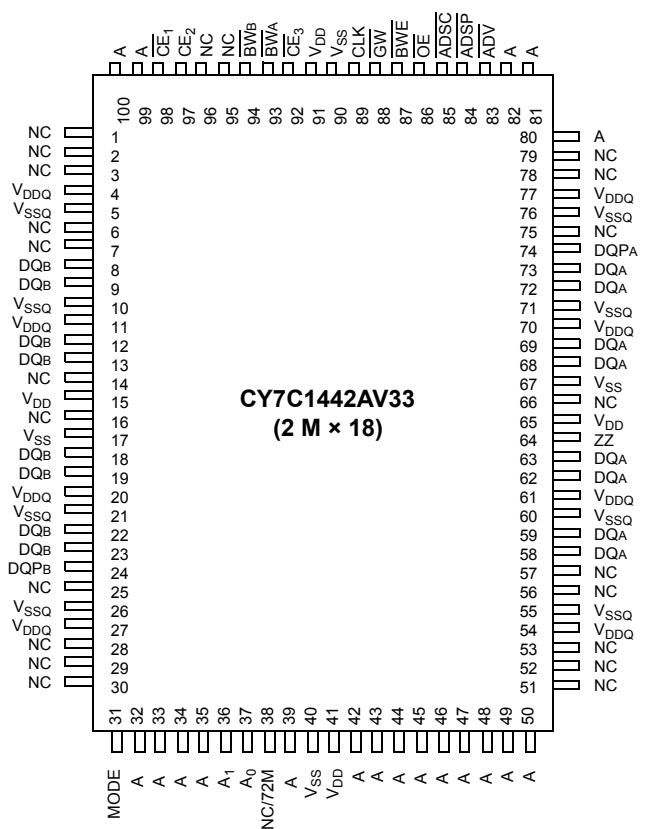
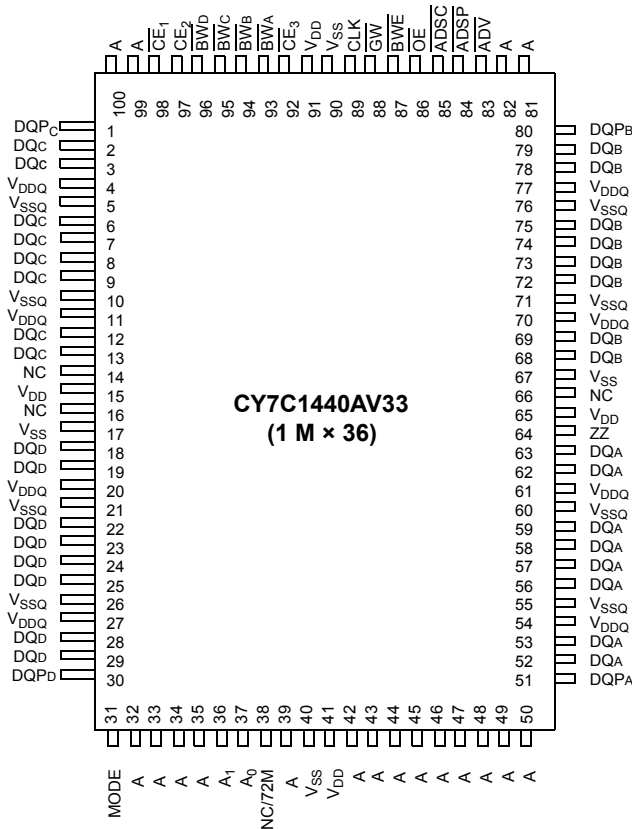

Pin Configurations (continued)

165-ball FBGA (15 × 17 × 1.4 mm) Pinout

CY7C1440AV33 (1 M × 36)

| | 1 | 2 | 3 | 4 | 5 | 6 | 7 | 8 | 9 | 10 | 11 |
|----------|------------------|-----------------|-------------------|-------------------|-------------------|-------------------|------------------|-------------------|-------------------|-----------------|------------------|
| A | NC/288M | A | \overline{CE}_1 | \overline{BW}_C | \overline{BW}_B | \overline{CE}_3 | \overline{BWE} | \overline{ADSC} | \overline{ADV} | A | NC |
| B | NC/144M | A | CE2 | \overline{BW}_D | \overline{BW}_A | CLK | \overline{GW} | \overline{OE} | \overline{ADSP} | A | NC/576M |
| C | DQP _C | NC | V _{DDQ} | V _{SS} | V _{SS} | V _{SS} | V _{SS} | V _{SS} | V _{DDQ} | NC/1G | DQP _B |
| D | DQ _C | DQ _C | V _{DDQ} | V _{DD} | V _{SS} | V _{SS} | V _{SS} | V _{DD} | V _{DDQ} | DQ _B | DQ _B |
| E | DQ _C | DQ _C | V _{DDQ} | V _{DD} | V _{SS} | V _{SS} | V _{SS} | V _{DD} | V _{DDQ} | DQ _B | DQ _B |
| F | DQ _C | DQ _C | V _{DDQ} | V _{DD} | V _{SS} | V _{SS} | V _{SS} | V _{DD} | V _{DDQ} | DQ _B | DQ _B |
| G | DQ _C | DQ _C | V _{DDQ} | V _{DD} | V _{SS} | V _{SS} | V _{SS} | V _{DD} | V _{DDQ} | DQ _B | DQ _B |
| H | NC | NC | NC | V _{DD} | V _{SS} | V _{SS} | V _{SS} | V _{DD} | NC | NC | ZZ |
| J | DQ _D | DQ _D | V _{DDQ} | V _{DD} | V _{SS} | V _{SS} | V _{SS} | V _{DD} | V _{DDQ} | DQ _A | DQ _A |
| K | DQ _D | DQ _D | V _{DDQ} | V _{DD} | V _{SS} | V _{SS} | V _{SS} | V _{DD} | V _{DDQ} | DQ _A | DQ _A |
| L | DQ _D | DQ _D | V _{DDQ} | V _{DD} | V _{SS} | V _{SS} | V _{SS} | V _{DD} | V _{DDQ} | DQ _A | DQ _A |
| M | DQ _D | DQ _D | V _{DDQ} | V _{DD} | V _{SS} | V _{SS} | V _{SS} | V _{DD} | V _{DDQ} | DQ _A | DQ _A |
| N | DQP _D | NC | V _{DDQ} | V _{SS} | NC | A | NC | V _{SS} | V _{DDQ} | NC | DQP _A |
| P | NC | NC/72M | A | A | TDI | A1 | TDO | A | A | A | A |
| R | MODE | A | A | A | TMS | A0 | TCK | A | A | A | A |

CY7C1442AV33 (2 M × 18)

| | 1 | 2 | 3 | 4 | 5 | 6 | 7 | 8 | 9 | 10 | 11 |
|----------|------------------|-----------------|-------------------|-------------------|-------------------|-------------------|------------------|-------------------|-------------------|-----------------|------------------|
| A | NC/288M | A | \overline{CE}_1 | \overline{BW}_B | NC | \overline{CE}_3 | \overline{BWE} | \overline{ADSC} | \overline{ADV} | A | A |
| B | NC/144M | A | CE2 | NC | \overline{BW}_A | CLK | \overline{GW} | \overline{OE} | \overline{ADSP} | A | NC/576M |
| C | NC | NC | V _{DDQ} | V _{SS} | V _{SS} | V _{SS} | V _{SS} | V _{SS} | V _{DDQ} | NC/1G | DQP _A |
| D | NC | DQ _B | V _{DDQ} | V _{DD} | V _{SS} | V _{SS} | V _{SS} | V _{DD} | V _{DDQ} | NC | DQ _A |
| E | NC | DQ _B | V _{DDQ} | V _{DD} | V _{SS} | V _{SS} | V _{SS} | V _{DD} | V _{DDQ} | NC | DQ _A |
| F | NC | DQ _B | V _{DDQ} | V _{DD} | V _{SS} | V _{SS} | V _{SS} | V _{DD} | V _{DDQ} | NC | DQ _A |
| G | NC | DQ _B | V _{DDQ} | V _{DD} | V _{SS} | V _{SS} | V _{SS} | V _{DD} | V _{DDQ} | NC | DQ _A |
| H | NC | NC | NC | V _{DD} | V _{SS} | V _{SS} | V _{SS} | V _{DD} | NC | NC | ZZ |
| J | DQ _B | NC | V _{DDQ} | V _{DD} | V _{SS} | V _{SS} | V _{SS} | V _{DD} | V _{DDQ} | DQ _A | NC |
| K | DQ _B | NC | V _{DDQ} | V _{DD} | V _{SS} | V _{SS} | V _{SS} | V _{DD} | V _{DDQ} | DQ _A | NC |
| L | DQ _B | NC | V _{DDQ} | V _{DD} | V _{SS} | V _{SS} | V _{SS} | V _{DD} | V _{DDQ} | DQ _A | NC |
| M | DQ _B | NC | V _{DDQ} | V _{DD} | V _{SS} | V _{SS} | V _{SS} | V _{DD} | V _{DDQ} | DQ _A | NC |
| N | DQP _B | NC | V _{DDQ} | V _{SS} | NC | A | NC | V _{SS} | V _{DDQ} | NC | NC |
| P | NC | NC/72M | A | A | TDI | A1 | TDO | A | A | A | A |
| R | MODE | A | A | A | TMS | A0 | TCK | A | A | A | A |

Pin Configurations (continued)

209-ball FBGA (14 × 22 × 1.76 mm) Pinout
CY7C1446AV33 (512 K × 72)

| | 1 | 2 | 3 | 4 | 5 | 6 | 7 | 8 | 9 | 10 | 11 |
|----------|------------------|------------------|------------------|------------------|-----------------|-----------------|-----------------|------------------|------------------|------------------|------------------|
| A | DQ _G | DQ _G | A | CE ₂ | ADSP | ADSC | ADV | CE ₃ | A | DQ _B | DQ _B |
| B | DQ _G | DQ _G | BWS _C | BWS _G | NC/288M | BW | A | BWS _B | BWS _F | DQ _B | DQ _B |
| C | DQ _G | DQ _G | BWS _H | BWS _D | NC/144M | CE ₁ | NC/576M | BWS _E | BWS _A | DQ _B | DQ _B |
| D | DQ _G | DQ _G | V _{SS} | NC | NC/1G | OE | GW | NC | V _{SS} | DQ _B | DQ _B |
| E | DQP _G | DQP _C | V _{DDQ} | V _{DDQ} | V _{DD} | V _{DD} | V _{DD} | V _{DDQ} | V _{DDQ} | DQP _F | DQP _B |
| F | DQ _C | DQ _C | V _{SS} | V _{SS} | V _{SS} | NC | V _{SS} | V _{SS} | V _{SS} | DQ _F | DQ _F |
| G | DQ _C | DQ _C | V _{DDQ} | V _{DDQ} | V _{DD} | NC | V _{DD} | V _{DDQ} | V _{DDQ} | DQ _F | DQ _F |
| H | DQ _C | DQ _C | V _{SS} | V _{SS} | V _{SS} | NC | V _{SS} | V _{SS} | V _{SS} | DQ _F | DQ _F |
| J | DQ _C | DQ _C | V _{DDQ} | V _{DDQ} | V _{DD} | NC | V _{DD} | V _{DDQ} | V _{DDQ} | DQ _F | DQ _F |
| K | NC | NC | CLK | NC | V _{SS} | V _{SS} | V _{SS} | NC | NC | NC | NC |
| L | DQ _H | DQ _H | V _{DDQ} | V _{DDQ} | V _{DD} | NC | V _{DD} | V _{DDQ} | V _{DDQ} | DQ _A | DQ _A |
| M | DQ _H | DQ _H | V _{SS} | V _{SS} | V _{SS} | NC | V _{SS} | V _{SS} | V _{SS} | DQ _A | DQ _A |
| N | DQ _H | DQ _H | V _{DDQ} | V _{DDQ} | V _{DD} | NC | V _{DD} | V _{DDQ} | V _{DDQ} | DQ _A | DQ _A |
| P | DQ _H | DQ _H | V _{SS} | V _{SS} | V _{SS} | ZZ | V _{SS} | V _{SS} | V _{SS} | DQ _A | DQ _A |
| R | DQP _D | DQP _H | V _{DDQ} | V _{DDQ} | V _{DD} | V _{DD} | V _{DD} | V _{DDQ} | V _{DDQ} | DQP _A | DQP _E |
| T | DQ _D | DQ _D | V _{SS} | NC | NC | MODE | NC | NC | V _{SS} | DQ _E | DQ _E |
| U | DQ _D | DQ _D | NC/72M | A | A | A | A | A | A | DQ _E | DQ _E |
| V | DQ _D | DQ _D | A | A | A | A1 | A | A | A | DQ _E | DQ _E |
| W | DQ _D | DQ _D | TMS | TDI | A | A0 | A | TDO | TCK | DQ _E | DQ _E |

Pin Definitions

| Name | I/O | Description |
|---|-------------------|---|
| A ₀ , A ₁ , A | Input-synchronous | Address inputs used to select one of the address locations. Sampled at the rising edge of the CLK if ADSP or ADSC is active LOW, and CE ₁ , CE ₂ , and CE ₃ ^[2] are sampled active. A1: A0 are fed to the two-bit counter. |
| BW _A , BW _B , BW _C , BW _D , BW _E , BW _F , BW _G , BW _H | Input-synchronous | Byte write select inputs, active LOW. Qualified with BWE to conduct byte writes to the SRAM. Sampled on the rising edge of CLK. |
| GW | Input-synchronous | Global write enable input, active LOW. When asserted LOW on the rising edge of CLK, a global write is conducted (all bytes are written, regardless of the values on BW _X and BWE). |
| BWE | Input-synchronous | Byte write enable input, active LOW. Sampled on the rising edge of CLK. This signal must be asserted LOW to conduct a byte write. |
| CLK | Input-clock | Clock input. Used to capture all synchronous inputs to the device. Also used to increment the burst counter when ADV is asserted LOW, during a burst operation. |
| CE ₁ | Input-synchronous | Chip enable 1 input, active LOW. Sampled on the rising edge of CLK. Used in conjunction with CE ₂ and CE ₃ to select/deselect the device. ADSP is ignored if CE ₁ is HIGH. CE ₁ is sampled only when a new external address is loaded. |

Note

2. X = "Don't Care." H = Logic HIGH, L = Logic LOW.

Pin Definitions (continued)

| Name | I/O | Description |
|--|--------------------------------|---|
| CE ₂ | Input-synchronous | Chip enable 2 input, active HIGH. Sampled on the rising edge of CLK. Used in conjunction with CE ₁ and CE ₃ to select/deselect the device. CE ₂ is sampled only when a new external address is loaded. |
| CE ₃ | Input-synchronous | Chip enable 3 input, active LOW. Sampled on the rising edge of CLK. Used in conjunction with CE ₁ and CE ₂ to select/deselect the device. Not available for AJ package version. Not connected for BGA. Where referenced, CE ₃ is assumed active throughout this document for BGA. CE ₃ is sampled only when a new external address is loaded. |
| OE | Input-asynchronous | Output enable, asynchronous input, active LOW. Controls the direction of the I/O pins. When LOW, the I/O pins behave as outputs. When deasserted HIGH, I/O pins are tri-stated, and act as input data pins. OE is masked during the first clock of a read cycle when emerging from a deselected state. |
| ADV | Input-synchronous | Advance input signal, sampled on the rising edge of CLK, active LOW. When asserted, it automatically increments the address in a burst cycle. |
| ADSP | Input-synchronous | Address strobe from processor, sampled on the rising edge of CLK, active LOW. When asserted LOW, addresses presented to the device are captured in the address registers. A1: A0 are also loaded into the burst counter. When ADSP and ADSC are both asserted, only ADSP is recognized. ADSP is ignored when CE ₁ is deasserted HIGH. |
| ADSC | Input-synchronous | Address strobe from controller, sampled on the rising edge of CLK, active LOW. When asserted LOW, addresses presented to the device are captured in the address registers. A1: A0 are also loaded into the burst counter. When ADSP and ADSC are both asserted, only ADSP is recognized. |
| ZZ | Input-asynchronous | ZZ “sleep” input, active HIGH. When asserted HIGH places the device in a non-time-critical “sleep” condition with data integrity preserved. For normal operation, this pin has to be LOW or left floating. ZZ pin has an internal pull-down. |
| DQ _s , DQP _x | I/O-synchronous | Bidirectional data I/O lines. As inputs, they feed into an on-chip data register that is triggered by the rising edge of CLK. As outputs, they deliver the data contained in the memory location specified by the addresses presented during the previous clock rise of the read cycle. The direction of the pins is controlled by OE. When OE is asserted LOW, the pins behave as outputs. When HIGH, DQ _s and DQP _x are placed in a tri-state condition. |
| V _{DD} | Power supply | Power supply inputs to the core of the device. |
| V _{SS} | Ground | Ground for the core of the device. |
| V _{SSQ} | I/O ground | Ground for the I/O circuitry. |
| V _{DDQ} | I/O power supply | Power supply for the I/O circuitry. |
| MODE | Input-static | Selects burst order. When tied to GND selects linear burst sequence. When tied to V _{DD} or left floating selects interleaved burst sequence. This is a strap pin and should remain static during device operation. Mode pin has an internal pull-up. |
| TDO | JTAG serial output synchronous | Serial data-out to the JTAG circuit. Delivers data on the negative edge of TCK. If the JTAG feature is not being utilized, this pin should be disconnected. This pin is not available on TQFP packages. |
| TDI | JTAG serial input synchronous | Serial data-in to the JTAG circuit. Sampled on the rising edge of TCK. If the JTAG feature is not being utilized, this pin can be disconnected or connected to V _{DD} . This pin is not available on TQFP packages. |
| TMS | JTAG serial input synchronous | Serial data-in to the JTAG circuit. Sampled on the rising edge of TCK. If the JTAG feature is not being utilized, this pin can be disconnected or connected to V _{DD} . This pin is not available on TQFP packages. |
| TCK | JTAG-clock | Clock input to the JTAG circuitry. If the JTAG feature is not being utilized, this pin must be connected to V _{SS} . This pin is not available on TQFP packages. |
| NC | – | No connects. Not internally connected to the die |
| NC/72M, NC/144M, NC/288M, NC/576M, NC/1G | – | No connects. Not internally connected to the die. NC/72M, NC/144M, NC/288M, NC/576M and NC/1G are address expansion pins are not internally connected to the die. |

Functional Overview

All synchronous inputs pass through input registers controlled by the rising edge of the clock. All data outputs pass through output registers controlled by the rising edge of the clock. Maximum access delay from the clock rise (t_{CO}) is 2.6 ns (250-MHz device).

The CY7C1440AV33/CY7C1442AV33/CY7C1446AV33 supports secondary cache in systems utilizing either a linear or interleaved burst sequence. The interleaved burst order supports Pentium and i486™ processors. The linear burst sequence is suited for processors that utilize a linear burst sequence. The burst order is user selectable, and is determined by sampling the MODE input. Accesses can be initiated with either the processor address strobe (ADSP) or the controller address strobe (ADSC). Address advancement through the burst sequence is controlled by the ADV input. A two-bit on-chip wraparound burst counter captures the first address in a burst sequence and automatically increments the address for the rest of the burst access.

Byte write operations are qualified with the byte write enable (BWE) and byte write select (BW_X) inputs. A global write enable (\overline{GW}) overrides all byte write inputs and writes data to all four bytes. All writes are simplified with on-chip synchronous self-timed Write circuitry.

Three synchronous chip selects (\overline{CE}_1 , CE_2 , \overline{CE}_3) and an asynchronous output enable (\overline{OE}) provide for easy bank selection and output tri-state control. ADSP is ignored if \overline{CE}_1 is HIGH.

Single Read Accesses

This access is initiated when the following conditions are satisfied at clock rise: (1) ADSP or ADSC is asserted LOW, (2) \overline{CE}_1 , CE_2 , CE_3 are all asserted active, and (3) the write signals (\overline{GW} , BWE) are all deserted HIGH. ADSP is ignored if \overline{CE}_1 is HIGH. The address presented to the address inputs (A) is stored into the address advancement logic and the address register while being presented to the memory array. The corresponding data is allowed to propagate to the input of the output registers. At the rising edge of the next clock the data is allowed to propagate through the output register and onto the data bus within 2.6 ns (250-MHz device) if \overline{OE} is active LOW. The only exception occurs when the SRAM is emerging from a deselected state to a selected state, its outputs are always tri-stated during the first cycle of the access. After the first cycle of the access, the outputs are controlled by the \overline{OE} signal. Consecutive single Read cycles are supported. Once the SRAM is deselected at clock rise by the chip select and either ADSP or ADSC signals, its output will tri-state immediately.

Single Write Accesses Initiated by ADSP

This access is initiated when both of the following conditions are satisfied at clock rise: (1) ADSP is asserted LOW, and (2) \overline{CE}_1 , CE_2 , \overline{CE}_3 are all asserted active. The address presented to A is loaded into the address register and the address advancement logic while being delivered to the memory array. The write signals (\overline{GW} , BWE, and BW_X) and ADV inputs are ignored during this first cycle.

ADSP-triggered write accesses require two clock cycles to complete. If \overline{GW} is asserted LOW on the second clock rise, the data presented to the DQs inputs is written into the

corresponding address location in the memory array. If \overline{GW} is HIGH, then the write operation is controlled by BWE and BW_X signals.

The CY7C1440AV33/CY7C1442AV33/CY7C1446AV33 provides byte write capability that is described in the Write Cycle Descriptions table. Asserting the byte write enable input (BWE) with the selected byte write (BW_X) input, will selectively write to only the desired bytes. Bytes not selected during a byte write operation will remain unaltered. A synchronous self-timed Write mechanism has been provided to simplify the write operations.

Because CY7C1440AV33/CY7C1442AV33/CY7C1446AV33 is a common I/O device, the output enable (\overline{OE}) must be deasserted HIGH before presenting data to the DQs inputs. Doing so will tri-state the output drivers. As a safety precaution, DQs are automatically tri-stated whenever a Write cycle is detected, regardless of the state of \overline{OE} .

Single Write Accesses Initiated by ADSC

ADSC Write accesses are initiated when the following conditions are satisfied: (1) ADSC is asserted LOW, (2) ADSP is deserted HIGH, (3) \overline{CE}_1 , CE_2 , CE_3 are all asserted active, and (4) the appropriate combination of the Write inputs (\overline{GW} , BWE, and BW_X) are asserted active to conduct a Write to the desired byte(s). ADSC-triggered write accesses require a single clock cycle to complete. The address presented to A is loaded into the address register and the address advancement logic while being delivered to the memory array. The ADV input is ignored during this cycle. If a global Write is conducted, the data presented to the DQs is written into the corresponding address location in the memory core. If a byte write is conducted, only the selected bytes are written. Bytes not selected during a byte write operation will remain unaltered. A synchronous self-timed write mechanism has been provided to simplify the Write operations.

Because CY7C1440AV33/CY7C1442AV33/CY7C1446AV33 is a common I/O device, the output enable (\overline{OE}) must be deasserted HIGH before presenting data to the DQs inputs. Doing so will tri-state the output drivers. As a safety precaution, DQs are automatically tri-stated whenever a Write cycle is detected, regardless of the state of \overline{OE} .

Burst Sequences

The CY7C1440AV33/CY7C1442AV33/CY7C1446AV33 provides a two-bit wraparound counter, fed by A1: A0, that implements either an interleaved or linear burst sequence. The interleaved burst sequence is designed specifically to support Intel Pentium applications. The linear burst sequence is designed to support processors that follow a linear burst sequence. The burst sequence is user selectable through the MODE input. Asserting ADV LOW at clock rise will automatically increment the burst counter to the next address in the burst sequence. Both read and write burst operations are supported.

Sleep Mode

The ZZ input pin is an asynchronous input. Asserting ZZ places the SRAM in a power conservation "sleep" mode. Two clock cycles are required to enter into or exit from this "sleep" mode. While in this mode, data integrity is guaranteed. Accesses pending when entering the "sleep" mode are not considered valid nor is the completion of the operation

guaranteed. The device must be deselected prior to entering the “sleep” mode. \overline{CE}_1 , CE_2 , \overline{CE}_3 , \overline{ADSP} , and \overline{ADSC} must remain inactive for the duration of t_{ZZREC} after the ZZ input returns LOW.

Interleaved Burst Address Table (MODE = Floating or V_{DD})

| First Address A1: A0 | Second Address A1: A0 | Third Address A1: A0 | Fourth Address A1: A0 |
|-------------------------|--------------------------|-------------------------|--------------------------|
| 00 | 01 | 10 | 11 |
| 01 | 00 | 11 | 10 |
| 10 | 11 | 00 | 01 |
| 11 | 10 | 01 | 00 |

Linear Burst Address Table (MODE = GND)

| First Address A1: A0 | Second Address A1: A0 | Third Address A1: A0 | Fourth Address A1: A0 |
|-------------------------|--------------------------|-------------------------|--------------------------|
| 00 | 01 | 10 | 11 |
| 01 | 10 | 11 | 00 |
| 10 | 11 | 00 | 01 |
| 11 | 00 | 01 | 10 |

ZZ Mode Electrical Characteristics

| Parameter | Description | Test Conditions | Min | Max | Unit |
|-------------|-----------------------------------|---------------------------|------------|------------|------|
| I_{DDZZ} | Sleep mode standby current | $ZZ \geq V_{DD} - 0.2 V$ | – | 100 | mA |
| t_{ZZS} | Device operation to ZZ | $ZZ \geq V_{DD} - 0.2 V$ | – | $2t_{CYC}$ | ns |
| t_{ZZREC} | ZZ recovery time | $ZZ \leq 0.2 V$ | $2t_{CYC}$ | – | ns |
| t_{ZZI} | ZZ active to sleep current | This parameter is sampled | – | $2t_{CYC}$ | ns |
| t_{RZZI} | ZZ inactive to exit sleep current | This parameter is sampled | 0 | – | ns |

Truth Table [3, 4, 5, 6, 7, 8]

| Operation | Add. Used | \overline{CE}_1 | CE_2 | \overline{CE}_3 | ZZ | ADSP | ADSC | ADV | WRITE | OE | CLK | DQ |
|-----------------------------|-----------|-------------------|--------|-------------------|----|------|------|-----|-------|----|-----|-----------|
| Deselect cycle, power-down | None | H | X | X | L | X | L | X | X | X | L-H | Tri-state |
| Deselect cycle, power-down | None | L | L | X | L | L | X | X | X | X | L-H | Tri-state |
| Deselect cycle, power-down | None | L | X | H | L | L | X | X | X | X | L-H | Tri-state |
| Deselect cycle, power-down | None | L | L | X | L | H | L | X | X | X | L-H | Tri-state |
| Deselect cycle, power-down | None | L | X | H | L | H | L | X | X | X | L-H | Tri-state |
| Sleep mode, power-down | None | X | X | X | H | X | X | X | X | X | X | Tri-state |
| READ cycle, begin burst | External | L | H | L | L | L | X | X | X | L | L-H | Q |
| READ cycle, begin burst | External | L | H | L | L | L | X | X | X | H | L-H | Tri-state |
| WRITE cycle, begin burst | External | L | H | L | L | H | L | X | L | X | L-H | D |
| READ cycle, begin burst | External | L | H | L | L | H | L | X | H | L | L-H | Q |
| READ cycle, begin burst | External | L | H | L | L | H | L | X | H | H | L-H | Tri-state |
| READ cycle, continue burst | Next | X | X | X | L | H | H | L | H | L | L-H | Q |
| READ cycle, continue burst | Next | X | X | X | L | H | H | L | H | H | L-H | Tri-state |
| READ cycle, continue burst | Next | H | X | X | L | X | H | L | H | L | L-H | Q |
| READ cycle, continue burst | Next | H | X | X | L | X | H | L | H | H | L-H | Tri-state |
| WRITE cycle, continue burst | Next | X | X | X | L | H | H | L | L | X | L-H | D |
| WRITE cycle, continue burst | Next | H | X | X | L | X | H | L | L | X | L-H | D |
| READ cycle, suspend burst | Current | X | X | X | L | H | H | H | H | L | L-H | Q |
| READ cycle, suspend burst | Current | X | X | X | L | H | H | H | H | H | L-H | Tri-state |
| READ cycle, suspend burst | Current | H | X | X | L | X | H | H | H | L | L-H | Q |
| READ cycle, suspend burst | Current | H | X | X | L | X | H | H | H | H | L-H | Tri-state |
| WRITE cycle, suspend burst | Current | X | X | X | L | H | H | H | L | X | L-H | D |
| WRITE cycle, suspend burst | Current | H | X | X | L | X | H | H | L | X | L-H | D |

Notes

- X = "Don't Care." H = Logic HIGH, L = Logic LOW.
- WRITE = L when any one or more byte write enable signals and $\overline{BWE} = L$ or $\overline{GW} = L$. WRITE = H when all byte write enable signals, \overline{BWE} , $\overline{GW} = H$.
- The DQ pins are controlled by the current cycle and the OE signal. OE is asynchronous and is not sampled with the clock.
- CE_1 , CE_2 , and CE_3 are available only in the TQFP package. BGA package has only 2 chip selects CE_1 and CE_2 .
- The SRAM always initiates a read cycle when ADSP is asserted, regardless of the state of \overline{GW} , \overline{BWE} , or \overline{BW}_x . Writes may occur only on subsequent clocks after the ADSP or with the assertion of ADSC. As a result, OE must be driven HIGH prior to the start of the write cycle to allow the outputs to tri-state. OE is a don't care for the remainder of the write cycle.
- OE is asynchronous and is not sampled with the clock rise. It is masked internally during write cycles. During a read cycle all data bits are tri-state when \overline{OE} is inactive or when the device is deselected, and all data bits behave as output when OE is active (LOW).

Truth Table for Read/Write^[9, 10, 11]

| Function (CY7C1440AV33) | \overline{GW} | \overline{BWE} | \overline{BW}_D | \overline{BW}_C | \overline{BW}_B | \overline{BW}_A |
|--|-----------------|------------------|-------------------|-------------------|-------------------|-------------------|
| Read | H | H | X | X | X | X |
| Read | H | L | H | H | H | H |
| Write byte A – (DQ _A and DQP _A) | H | L | H | H | H | L |
| Write byte B – (DQ _B and DQP _B) | H | L | H | H | L | H |
| Write bytes B, A | H | L | H | H | L | L |
| Write byte C – (DQ _C and DQP _C) | H | L | H | L | H | H |
| Write bytes C, A | H | L | H | L | H | L |
| Write bytes C, B | H | L | H | L | L | H |
| Write bytes C, B, A | H | L | H | L | L | L |
| Write byte D – (DQ _D and DQP _D) | H | L | L | H | H | H |
| Write bytes D, A | H | L | L | H | H | L |
| Write bytes D, B | H | L | L | H | L | H |
| Write bytes D, B, A | H | L | L | H | L | L |
| Write bytes D, C | H | L | L | L | H | H |
| Write bytes D, C, A | H | L | L | L | H | L |
| Write bytes D, C, B | H | L | L | L | L | H |
| Write all bytes | H | L | L | L | L | L |
| Write all bytes | L | X | X | X | X | X |

Truth Table for Read/Write^[9, 10, 11]

| Function (CY7C1442AV33) | \overline{GW} | \overline{BWE} | \overline{BW}_B | \overline{BW}_A |
|--|-----------------|------------------|-------------------|-------------------|
| Read | H | H | X | X |
| Read | H | L | H | H |
| Write byte A – (DQ _A and DQP _A) | H | L | H | L |
| Write byte B – (DQ _B and DQP _B) | H | L | L | H |
| Write bytes B, A | H | L | L | L |
| Write all bytes | H | L | L | L |
| Write all bytes | L | X | X | X |

Truth Table for Read/Write^[9, 10, 11]

| Function (CY7C1446AV33) | \overline{GW} | \overline{BWE} | \overline{BW}_x |
|--|-----------------|------------------|-------------------------|
| Read | H | H | X |
| Read | H | L | All $\overline{BW} = H$ |
| Write byte x – (DQ _x and DQP _x) | H | L | L |
| Write all bytes | H | L | All $\overline{BW} = L$ |
| Write all bytes | L | X | X |

Notes

9. The DQ pins are controlled by the current cycle and the OE signal. OE is asynchronous and is not sampled with the clock.
10. \overline{BW}_x represents any byte write signal. To enable any byte write \overline{BW}_x , a Logic LOW signal should be applied at clock rise. Any number of byte writes can be enabled at the same time for any given write.
11. Table only lists a partial listing of the byte write combinations. Any combination of \overline{BW}_x is valid. Appropriate write will be done based on which byte write is active.

IEEE 1149.1 Serial Boundary Scan (JTAG)

The CY7C1440AV33/CY7C1442AV33/CY7C1446AV33 incorporates a serial boundary scan test access port (TAP). This part is fully compliant with IEEE Standard 1149.1. The TAP operates using JEDEC-standard 3.3 V or 2.5 V I/O logic levels.

The CY7C1440AV33/CY7C1442AV33/CY7C1446AV33 contains a TAP controller, instruction register, boundary scan register, bypass register, and ID register.

Disabling the JTAG Feature

It is possible to operate the SRAM without using the JTAG feature. To disable the TAP controller, TCK must be tied LOW (V_{SS}) to prevent clocking of the device. TDI and TMS are internally pulled up and may be unconnected. They may alternately be connected to V_{DD} through a pull-up resistor. TDO should be left unconnected. Upon power-up, the device will come up in a reset state which will not interfere with the operation of the device.

TAP Controller State Diagram

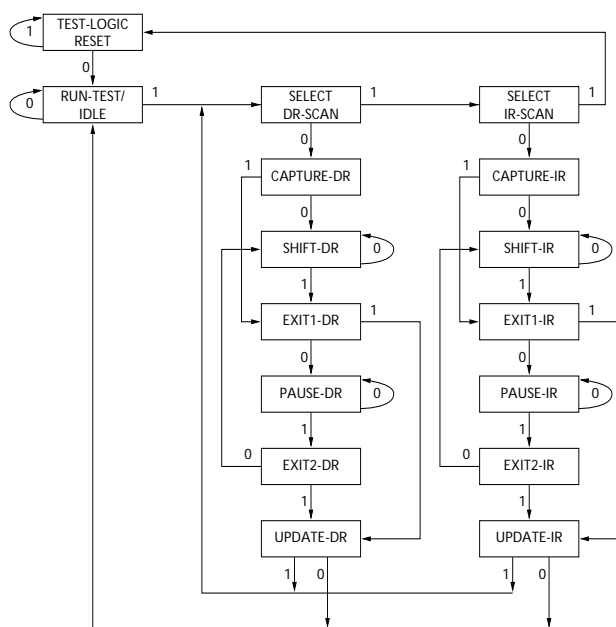

The 0/1 next to each state represents the value of TMS at the rising edge of TCK.

Test Access Port (TAP)

Test Clock (TCK)

The test clock is used only with the TAP controller. All inputs are captured on the rising edge of TCK. All outputs are driven from the falling edge of TCK.

Test Mode Select (TMS)

The TMS input is used to give commands to the TAP controller and is sampled on the rising edge of TCK. It is allowable to leave this ball unconnected if the TAP is not used. The ball is pulled up internally, resulting in a logic HIGH level.

Test Data-In (TDI)

The TDI ball is used to serially input information into the registers and can be connected to the input of any of the registers. The register between TDI and TDO is chosen by the instruction that is loaded into the TAP instruction register. TDI is internally pulled up and can be unconnected if the TAP is unused in an application. TDI is connected to the most significant bit (MSB) of any register. (See [TAP Controller Block Diagram](#).)

Test Data-Out (TDO)

The TDO output ball is used to serially clock data-out from the registers. The output is active depending upon the current state of the TAP state machine. The output changes on the falling edge of TCK. TDO is connected to the least significant bit (LSB) of any register. (See [TAP Controller State Diagram](#).)

TAP Controller Block Diagram

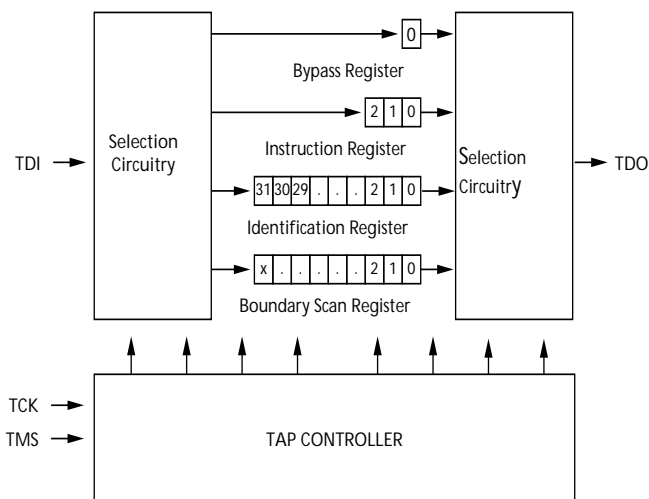

Performing a TAP Reset

A RESET is performed by forcing TMS HIGH (V_{DD}) for five rising edges of TCK. This RESET does not affect the operation of the SRAM and may be performed while the SRAM is operating.

At power-up, the TAP is reset internally to ensure that TDO comes up in a high Z state.

TAP Registers

Registers are connected between the TDI and TDO balls and allow data to be scanned into and out of the SRAM test circuitry. Only one register can be selected at a time through the instruction register. Data is serially loaded into the TDI ball on the rising edge of TCK. Data is output on the TDO ball on the falling edge of TCK.

Instruction Register

Three-bit instructions can be serially loaded into the instruction register. This register is loaded when it is placed between the TDI and TDO balls as shown in the [TAP Controller Block Diagram](#). Upon power-up, the instruction register is loaded with the IDCODE instruction. It is also loaded with the IDCODE instruction if the controller is placed in a reset state as described in the previous section.

When the TAP controller is in the Capture-IR state, the two least significant bits are loaded with a binary “01” pattern to allow for fault isolation of the board-level serial test data path.

Bypass Register

To save time when serially shifting data through registers, it is sometimes advantageous to skip certain chips. The bypass register is a single-bit register that can be placed between the TDI and TDO balls. This allows data to be shifted through the SRAM with minimal delay. The bypass register is set LOW (V_{SS}) when the BYPASS instruction is executed.

Boundary Scan Register

The boundary scan register is connected to all the input and bidirectional balls on the SRAM.

The boundary scan register is loaded with the contents of the RAM I/O ring when the TAP controller is in the Capture-DR state and is then placed between the TDI and TDO balls when the controller is moved to the Shift-DR state. The EXTEST, SAMPLE/PRELOAD and SAMPLE Z instructions can be used to capture the contents of the I/O ring.

The Boundary Scan Order tables show the order in which the bits are connected. Each bit corresponds to one of the bumps on the SRAM package. The MSB of the register is connected to TDI, and the LSB is connected to TDO.

Identification (ID) Register

The ID register is loaded with a vendor-specific, 32-bit code during the Capture-DR state when the IDCODE command is loaded in the instruction register. The IDCODE is hardwired into the SRAM and can be shifted out when the TAP controller is in the Shift-DR state. The ID register has a vendor code and other information described in the Identification Register Definitions table.

TAP Instruction Set

Overview

Eight different instructions are possible with the three bit instruction register. All combinations are listed in the Instruction Codes table. Three of these instructions are listed as RESERVED and should not be used. The other five instructions are described in detail below.

Instructions are loaded into the TAP controller during the Shift-IR state when the instruction register is placed between TDI and TDO. During this state, instructions are shifted through the instruction register through the TDI and TDO balls. To execute the instruction once it is shifted in, the TAP controller needs to be moved into the Update-IR state.

IDCODE

The IDCODE instruction causes a vendor-specific, 32-bit code to be loaded into the instruction register. It also places the instruction register between the TDI and TDO balls and allows the IDCODE to be shifted out of the device when the TAP controller enters the Shift-DR state.

The IDCODE instruction is loaded into the instruction register upon power-up or whenever the TAP controller is given a test logic reset state.

SAMPLE Z

The SAMPLE Z instruction causes the boundary scan register to be connected between the TDI and TDO pins when the TAP controller is in a Shift-DR state. The SAMPLE Z command puts the output bus into a high Z state until the next command is given during the “Update IR” state.

SAMPLE/PRELOAD

SAMPLE/PRELOAD is a 1149.1 mandatory instruction. When the SAMPLE/PRELOAD instructions are loaded into the instruction register and the TAP controller is in the Capture-DR state, a snapshot of data on the inputs and output pins is captured in the boundary scan register.

The user must be aware that the TAP controller clock can only operate at a frequency up to 20 MHz, while the SRAM clock operates more than an order of magnitude faster. Because there is a large difference in the clock frequencies, it is possible that during the Capture-DR state, an input or output will undergo a transition. The TAP may then try to capture a signal while in transition (metastable state). This will not harm the device, but there is no guarantee as to the value that will be captured. Repeatable results may not be possible.

To guarantee that the boundary scan register will capture the correct value of a signal, the SRAM signal must be stabilized long enough to meet the TAP controller’s capture set-up plus hold times (t_{CS} and t_{CH}). The SRAM clock input might not be captured correctly if there is no way in a design to stop (or slow) the clock during a SAMPLE/PRELOAD instruction. If this is an issue, it is still possible to capture all other signals and simply ignore the value of the CK and \overline{CK} captured in the boundary scan register.

Once the data is captured, it is possible to shift out the data by putting the TAP into the Shift-DR state. This places the boundary scan register between the TDI and TDO pins.

PRELOAD allows an initial data pattern to be placed at the latched parallel outputs of the boundary scan register cells prior to the selection of another boundary scan test operation.

The shifting of data for the SAMPLE and PRELOAD phases can occur concurrently when required—that is, while data captured is shifted out, the preloaded data can be shifted in.

BYPASS

When the BYPASS instruction is loaded in the instruction register and the TAP is placed in a Shift-DR state, the bypass register is placed between the TDI and TDO pins. The advantage of the BYPASS instruction is that it shortens the boundary scan path when multiple devices are connected together on a board.

EXTEST

The EXTEST instruction enables the preloaded data to be driven out through the system output pins. This instruction also selects the boundary scan register to be connected for serial access between the TDI and TDO in the shift-DR controller state.

EXTEST OUTPUT BUS TRI-STATE

IEEE Standard 1149.1 mandates that the TAP controller be able to put the output bus into a tri-state mode.

The boundary scan register has a special bit located at, bit #89 (for 165-ball FBGA package) or bit #138 (for 209-ball FBGA package).

package). When this scan cell, called the “extest output bus tri-state”, is latched into the preload register during the “Update-DR” state in the TAP controller, it will directly control the state of the output (Q-bus) pins, when the EXTEST is entered as the current instruction. When HIGH, it will enable the output buffers to drive the output bus. When LOW, this bit will place the output bus into a high Z condition.

This bit can be set by entering the SAMPLE/PRELOAD or EXTEST command, and then shifting the desired bit into that cell, during the “Shift-DR” state. During “Update-DR”, the value

loaded into that shift-register cell will latch into the preload register. When the EXTEST instruction is entered, this bit will directly control the output Q-bus pins. Note that this bit is pre-set HIGH to enable the output when the device is powered-up, and also when the TAP controller is in the “Test-Logic-Reset” state.

Reserved

These instructions are not implemented but are reserved for future use. Do not use these instructions.

TAP Timing

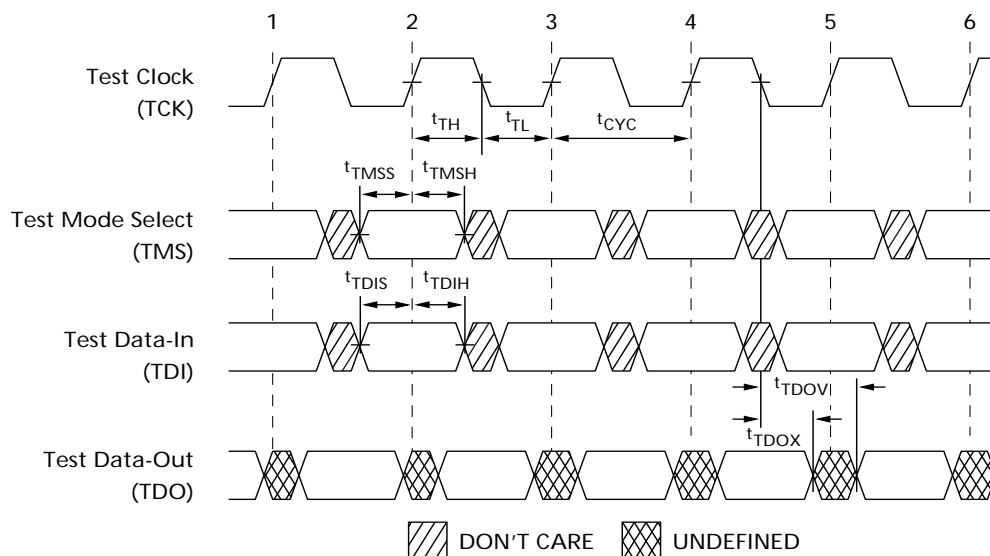

TAP AC Switching Characteristics

Over the operating Range^[12, 13]

| Parameter | Description | Min | Max | Unit |
|---------------------|-------------------------------|-----|-----|------|
| Clock | | | | |
| t_{TCYC} | TCK clock cycle time | 50 | – | ns |
| t_{TF} | TCK clock frequency | – | 20 | MHz |
| t_{TH} | TCK clock HIGH time | 20 | – | ns |
| t_{TL} | TCK clock LOW time | 20 | – | ns |
| Output Times | | | | |
| t_{TDOV} | TCK clock LOW to TDO valid | – | 10 | ns |
| t_{TDOX} | TCK clock LOW to TDO invalid | 0 | – | ns |
| Set-up Times | | | | |
| t_{TMSS} | TMS set-up to TCK clock rise | 5 | – | ns |
| t_{TDIS} | TDI set-up to TCK clock rise | 5 | – | ns |
| t_{CS} | Capture set-up to TCK rise | 5 | – | ns |
| Hold Times | | | | |
| t_{TMSH} | TMS hold after TCK clock rise | 5 | – | ns |
| t_{TDIH} | TDI hold after clock rise | 5 | – | ns |
| t_{CH} | Capture hold after clock rise | 5 | – | ns |

3.3 V TAP AC Test Conditions

Input pulse levels V_{SS} to 3.3 V
 Input rise and fall times 1 ns
 Input timing reference levels 1.5 V
 Output reference levels 1.5 V
 Test load termination supply voltage 1.5 V

3.3 V TAP AC Output Load Equivalent

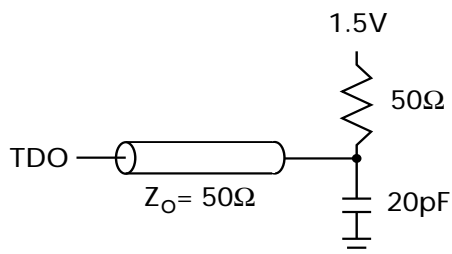

2.5 V TAP AC Test Conditions

Input pulse levels V_{SS} to 2.5 V
 Input rise and fall time 1 ns
 Input timing reference levels 1.25 V
 Output reference levels 1.25 V
 Test load termination supply voltage 1.25 V

2.5 V TAP AC Output Load Equivalent

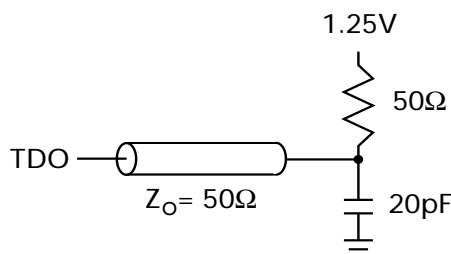

Notes

12. t_{CS} and t_{CH} refer to the set-up and hold time requirements of latching data from the boundary scan register.
 13. Test conditions are specified using the load in TAP AC test Conditions. $t_R/t_F = 1$ ns.

TAP DC Electrical Characteristics and Operating Conditions

(0 °C < T_A < +70 °C; V_{DD} = 3.135 to 3.6 V unless otherwise noted)^[14]

| Parameter | Description | Test Conditions | Min | Max | Unit | |
|------------------|---------------------|---|--------------------------|------|-----------------------|---|
| V _{OH1} | Output HIGH voltage | I _{OH} = -4.0 mA, V _{DDQ} = 3.3 V | 2.4 | - | V | |
| | | I _{OH} = -1.0 mA, V _{DDQ} = 2.5 V | 2.0 | - | V | |
| V _{OH2} | Output HIGH voltage | I _{OH} = -100 μA | V _{DDQ} = 3.3 V | 2.9 | - | V |
| | | | V _{DDQ} = 2.5 V | 2.1 | - | V |
| V _{OL1} | Output LOW voltage | I _{OL} = 8.0 mA | V _{DDQ} = 3.3 V | - | 0.4 | V |
| | | I _{OL} = 1.0 mA | V _{DDQ} = 2.5 V | - | 0.4 | V |
| V _{OL2} | Output LOW voltage | I _{OL} = 100 μA | V _{DDQ} = 3.3 V | - | 0.2 | V |
| | | | V _{DDQ} = 2.5 V | - | 0.2 | V |
| V _{IH} | Input HIGH voltage | | V _{DDQ} = 3.3 V | 2.0 | V _{DD} + 0.3 | V |
| | | | V _{DDQ} = 2.5 V | 1.7 | V _{DD} + 0.3 | V |
| V _{IL} | Input LOW voltage | | V _{DDQ} = 3.3 V | -0.3 | 0.8 | V |
| | | | V _{DDQ} = 2.5 V | -0.3 | 0.7 | V |
| I _X | Input load current | GND ≤ V _{IN} ≤ V _{DDQ} | -5 | 5 | μA | |

Identification Register Definitions

| Instruction Field | CY7C1440AV33 (1 M × 36) | CY7C1442AV33 (2 M × 18) | CY7C1446AV33 (512 K × 72) | Description |
|--------------------------------------|----------------------------|----------------------------|------------------------------|--|
| Revision number (31:29) | 000 | 000 | 000 | Describes the version number. |
| Device depth (28:24) ^[15] | 01011 | 01011 | 01011 | Reserved for internal use |
| Architecture/memory type(23:18) | 000000 | 000000 | 000000 | Defines memory type and architecture |
| Bus width/density(17:12) | 100111 | 010111 | 110111 | Defines width and density |
| Cypress JEDEC ID code (11:1) | 00000110100 | 00000110100 | 00000110100 | Allows unique identification of SRAM vendor. |
| ID register presence indicator (0) | 1 | 1 | 1 | Indicates the presence of an ID register. |

Scan Register Sizes

| Register Name | Bit Size (x 36) | Bit Size (x 18) | Bit Size (x 72) |
|---|-----------------|-----------------|-----------------|
| Instruction | 3 | 3 | 3 |
| Bypass | 1 | 1 | 1 |
| ID | 32 | 32 | 32 |
| Boundary scan order (165-ball FBGA package) | 89 | 89 | - |
| Boundary scan order (209-ball FBGA package) | - | - | 138 |

Identification Codes

| Instruction | Code | Description |
|-------------|------|--|
| EXTEST | 000 | Captures the I/O ring contents. |
| IDCODE | 001 | Loads the ID register with the vendor ID code and places the register between TDI and TDO. This operation does not affect SRAM operations. |
| SAMPLE Z | 010 | Captures I/O ring contents. Places the boundary scan register between TDI and TDO. Forces all SRAM output drivers to a high Z state. |
| RESERVED | 011 | Do Not Use: This instruction is reserved for future use. |

Notes

14. All voltages referenced to V_{SS} (GND).

15. Bit #24 is "1" in the ID Register Definitions for both 2.5 V and 3.3 V versions of this device.

Identification Codes (continued)

| Instruction | Code | Description |
|----------------|------|--|
| SAMPLE/PRELOAD | 100 | Captures I/O ring contents. Places the boundary scan register between TDI and TDO. Does not affect SRAM operation. |
| RESERVED | 101 | Do Not Use: This instruction is reserved for future use. |
| RESERVED | 110 | Do Not Use: This instruction is reserved for future use. |
| BYPASS | 111 | Places the bypass register between TDI and TDO. This operation does not affect SRAM operations. |

165-ball FBGA Boundary Scan Order [16, 17]

CY7C1440AV33 (1 M × 36), CY7C1442AV33 (2 M × 18)

| Bit # | ball ID | Bit # | ball ID | Bit # | ball ID | Bit # | ball ID |
|-------|---------|-------|---------|-------|---------|-------|----------|
| 1 | N6 | 26 | E11 | 51 | A3 | 76 | N1 |
| 2 | N7 | 27 | D11 | 52 | A2 | 77 | N2 |
| 3 | N10 | 28 | G10 | 53 | B2 | 78 | P1 |
| 4 | P11 | 29 | F10 | 54 | C2 | 79 | R1 |
| 5 | P8 | 30 | E10 | 55 | B1 | 80 | R2 |
| 6 | R8 | 31 | D10 | 56 | A1 | 81 | P3 |
| 7 | R9 | 32 | C11 | 57 | C1 | 82 | R3 |
| 8 | P9 | 33 | A11 | 58 | D1 | 83 | P2 |
| 9 | P10 | 34 | B11 | 59 | E1 | 84 | R4 |
| 10 | R10 | 35 | A10 | 60 | F1 | 85 | P4 |
| 11 | R11 | 36 | B10 | 61 | G1 | 86 | N5 |
| 12 | H11 | 37 | A9 | 62 | D2 | 87 | P6 |
| 13 | N11 | 38 | B9 | 63 | E2 | 88 | R6 |
| 14 | M11 | 39 | C10 | 64 | F2 | 89 | Internal |
| 15 | L11 | 40 | A8 | 65 | G2 | | |
| 16 | K11 | 41 | B8 | 66 | H1 | | |
| 17 | J11 | 42 | A7 | 67 | H3 | | |
| 18 | M10 | 43 | B7 | 68 | J1 | | |
| 19 | L10 | 44 | B6 | 69 | K1 | | |
| 20 | K10 | 45 | A6 | 70 | L1 | | |
| 21 | J10 | 46 | B5 | 71 | M1 | | |
| 22 | H9 | 47 | A5 | 72 | J2 | | |
| 23 | H10 | 48 | A4 | 73 | K2 | | |
| 24 | G11 | 49 | B4 | 74 | L2 | | |
| 25 | F11 | 50 | B3 | 75 | M2 | | |

Notes

- 16. Balls that are NC (No Connect) are preset LOW.
- 17. Bit# 89 is preset HIGH.

209-ball FBGA Boundary Scan Order [18, 19]

CY7C1446AV33 (512 K × 72)

| Bit # | ball ID | Bit # | ball ID | Bit # | ball ID | Bit # | ball ID |
|-------|---------|-------|---------|-------|---------|-------|----------|
| 1 | W6 | 36 | F6 | 71 | H6 | 106 | K3 |
| 2 | V6 | 37 | K8 | 72 | C6 | 107 | K4 |
| 3 | U6 | 38 | K9 | 73 | B6 | 108 | K6 |
| 4 | W7 | 39 | K10 | 74 | A6 | 109 | K2 |
| 5 | V7 | 40 | J11 | 75 | A5 | 110 | L2 |
| 6 | U7 | 41 | J10 | 76 | B5 | 111 | L1 |
| 7 | T7 | 42 | H11 | 77 | C5 | 112 | M2 |
| 8 | V8 | 43 | H10 | 78 | D5 | 113 | M1 |
| 9 | U8 | 44 | G11 | 79 | D4 | 114 | N2 |
| 10 | T8 | 45 | G10 | 80 | C4 | 115 | N1 |
| 11 | V9 | 46 | F11 | 81 | A4 | 116 | P2 |
| 12 | U9 | 47 | F10 | 82 | B4 | 117 | P1 |
| 13 | P6 | 48 | E10 | 83 | C3 | 118 | R2 |
| 14 | W11 | 49 | E11 | 84 | B3 | 119 | R1 |
| 15 | W10 | 50 | D11 | 85 | A3 | 120 | T2 |
| 16 | V11 | 51 | D10 | 86 | A2 | 121 | T1 |
| 17 | V10 | 52 | C11 | 87 | A1 | 122 | U2 |
| 18 | U11 | 53 | C10 | 88 | B2 | 123 | U1 |
| 19 | U10 | 54 | B11 | 89 | B1 | 124 | V2 |
| 20 | T11 | 55 | B10 | 90 | C2 | 125 | V1 |
| 21 | T10 | 56 | A11 | 91 | C1 | 126 | W2 |
| 22 | R11 | 57 | A10 | 92 | D2 | 127 | W1 |
| 23 | R10 | 58 | C9 | 93 | D1 | 128 | T6 |
| 24 | P11 | 59 | B9 | 94 | E1 | 129 | U3 |
| 25 | P10 | 60 | A9 | 95 | E2 | 130 | V3 |
| 26 | N11 | 61 | D7 | 96 | F2 | 131 | T4 |
| 27 | N10 | 62 | C8 | 97 | F1 | 132 | T5 |
| 28 | M11 | 63 | B8 | 98 | G1 | 133 | U4 |
| 29 | M10 | 64 | A8 | 99 | G2 | 134 | V4 |
| 30 | L11 | 65 | D8 | 100 | H2 | 135 | 5W |
| 31 | L10 | 66 | C7 | 101 | H1 | 136 | 5V |
| 32 | K11 | 67 | B7 | 102 | J2 | 137 | 5U |
| 33 | M6 | 68 | A7 | 103 | J1 | 138 | Internal |
| 34 | L6 | 69 | D6 | 104 | K1 | | |
| 35 | J6 | 70 | G6 | 105 | N6 | | |

Notes

- 18. Balls that are NC (No Connect) are preset LOW.
- 19. Bit# 138 is preset HIGH.

Maximum Ratings

Exceeding maximum ratings may shorten the useful life of the device. User guidelines are not tested.

Storage temperature -65 °C to +150 °C
 Ambient temperature with power applied -55 °C to +125 °C
 Supply voltage on V_{DD} relative to GND -0.3 V to +4.6 V
 Supply voltage on V_{DDQ} relative to GND -0.3 V to +V_{DD}
 DC voltage applied to outputs in tri-state -0.5 V to V_{DDQ} + 0.5 V

DC input voltage -0.5 V to V_{DD} + 0.5 V
 Current into outputs (LOW) 20 mA
 Static discharge voltage > 2001 V (per MIL-STD-883, method 3015)
 Latch-up current > 200 mA

Operating Range

| Range | Ambient Temperature | V _{DD} | V _{DDQ} |
|------------|---------------------|--------------------|-------------------------------|
| Commercial | 0 °C to +70 °C | 3.3 V – 5% / + 10% | 2.5 V – 5% to V _{DD} |
| Industrial | -40 °C to +85 °C | | |

Electrical Characteristics

Over the Operating Range^[20, 21]

| Parameter | Description | Test Conditions | Min | Max | Unit | |
|-------------------------|---|---|---------------------|------------------------|------|----|
| V _{DD} | Power supply voltage | | 3.135 | 3.6 | V | |
| V _{DDQ} | I/O supply voltage | for 3.3 V I/O | 3.135 | V _{DD} | V | |
| | | for 2.5 V I/O | 2.375 | 2.625 | V | |
| V _{OH} | Output HIGH voltage | for 3.3 V I/O, I _{OH} = -4.0 mA | 2.4 | - | V | |
| | | for 2.5 V I/O, I _{OH} = -1.0 mA | 2.0 | - | V | |
| V _{OL} | Output LOW voltage | for 3.3 V I/O, I _{OL} = 8.0 mA | - | 0.4 | V | |
| | | for 2.5 V I/O, I _{OL} = 1.0 mA | - | 0.4 | V | |
| V _{IH} | Input HIGH voltage ^[20] | for 3.3 V I/O | 2.0 | V _{DD} + 0.3V | V | |
| | | for 2.5 V I/O | 1.7 | V _{DD} + 0.3V | V | |
| V _{IL} | Input LOW voltage ^[20] | for 3.3 V I/O | -0.3 | 0.8 | V | |
| | | for 2.5 V I/O | -0.3 | 0.7 | V | |
| I _X | Input leakage current except ZZ and MODE | GND ≤ V _I ≤ V _{DDQ} | -5 | 5 | µA | |
| | Input current of MODE | Input = V _{SS} | -30 | - | µA | |
| | | Input = V _{DD} | - | 5 | µA | |
| | Input current of ZZ | Input = V _{SS} | -5 | - | µA | |
| Input = V _{DD} | | - | 30 | µA | | |
| I _{OZ} | Output leakage current | GND ≤ V _I ≤ V _{DDQ} , output disabled | -5 | 5 | µA | |
| I _{DD} | V _{DD} operating supply current | V _{DD} = Max, I _{OUT} = 0 mA, f = f _{MAX} = 1/t _{CYC} | 4-ns cycle, 250 MHz | - | 475 | mA |
| | | | 5-ns cycle, 200 MHz | - | 425 | mA |
| | | | 6-ns cycle, 167 MHz | - | 375 | mA |
| I _{SB1} | Automatic CE power-down current—TTL inputs | V _{DD} = Max, device deselected, V _{IN} ≥ V _{IH} or V _{IN} ≤ V _{IL} , f = f _{MAX} = 1/t _{CYC} | - | 225 | mA | |
| I _{SB2} | Automatic CE power-down current—CMOS inputs | V _{DD} = Max, device deselected, V _{IN} ≤ 0.3 V or V _{IN} ≥ V _{DDQ} - 0.3 V, f = 0 | - | 120 | mA | |
| I _{SB3} | Automatic CE power-down current—CMOS inputs | V _{DD} = Max, device deselected, or V _{IN} ≤ 0.3 V or V _{IN} ≥ V _{DDQ} - 0.3 V, f = f _{MAX} = 1/t _{CYC} | - | 200 | mA | |
| I _{SB4} | Automatic CE Power-down Current—TTL Inputs | V _{DD} = Max, device deselected, V _{IN} ≥ V _{IH} or V _{IN} ≤ V _{IL} , f = 0 | - | 135 | mA | |

Notes

20. Overshoot: V_{IH}(AC) < V_{DD} + 1.5 V (Pulse width less than t_{CYC}/2), undershoot: V_{IL}(AC) > -2 V (Pulse width less than t_{CYC}/2).

21. T_{Power-up}: Assumes a linear ramp from 0 V to V_{DD}(min) within 200 ms. During this time V_{IH} < V_{DD} and V_{DDQ} ≤ V_{DD}.

Capacitance^[22]

| Parameter | Description | Test Conditions | 100 TQFP Max | 165 FBGA Max | 209 FBGA Max | Unit |
|-----------|--------------------------|--|--------------|--------------|--------------|------|
| C_{IN} | Input capacitance | $T_A = 25\text{ }^\circ\text{C}$, $f = 1\text{ MHz}$, $V_{DD} = 3.3\text{ V}$ $V_{DDQ} = 2.5\text{ V}$ | 6.5 | 7 | 5 | pF |
| C_{CLK} | Clock input capacitance | | 3 | 7 | 5 | pF |
| $C_{I/O}$ | Input/output capacitance | | 5.5 | 6 | 7 | pF |

Thermal Resistance^[22]

| Parameter | Description | Test Conditions | 100 TQFP Package | 165 FBGA Package | 209 FBGA Package | Unit |
|---------------|--|--|------------------|------------------|------------------|--------------------|
| Θ_{JA} | Thermal resistance (junction to ambient) | Test conditions follow standard test methods and procedures for measuring thermal impedance, per EIA/JESD51. | 25.21 | 20.8 | 25.31 | $^\circ\text{C/W}$ |
| Θ_{JC} | Thermal resistance (junction to case) | | 2.28 | 3.2 | 4.48 | $^\circ\text{C/W}$ |

AC Test Loads and Waveforms

3.3 V I/O Test Load

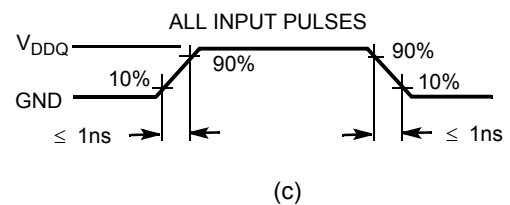
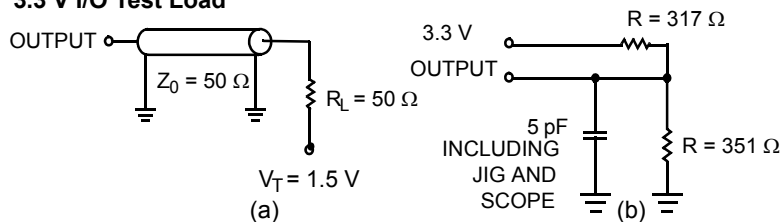

2.5 V I/O Test Load

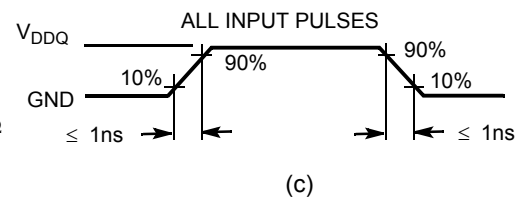
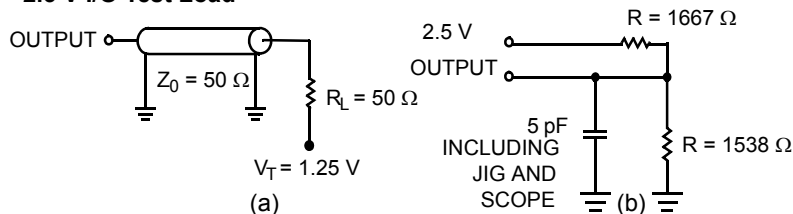

Note

22. Tested initially and after any design or process change that may affect these parameters.

Switching Characteristics

Over the Operating Range [23, 24]

| Parameter | Description | -250 | | -200 | | -167 | | Unit |
|---------------------|---|------|-----|------|-----|------|-----|------|
| | | Min | Max | Min | Max | Min | Max | |
| t _{POWER} | V _{DD} (Typical) to the first access ^[25] | 1 | – | 1 | – | 1 | – | ms |
| Clock | | | | | | | | |
| t _{CYC} | Clock cycle time | 4.0 | – | 5 | – | 6 | – | ns |
| t _{CH} | Clock HIGH | 1.5 | – | 2.0 | – | 2.4 | – | ns |
| t _{CL} | Clock LOW | 1.5 | – | 2.0 | – | 2.4 | – | ns |
| Output Times | | | | | | | | |
| t _{CO} | Data output valid after CLK rise | – | 2.6 | – | 3.2 | – | 3.4 | ns |
| t _{DOH} | Data output hold after CLK rise | 1.0 | – | 1.5 | – | 1.5 | – | ns |
| t _{CLZ} | Clock to low Z ^[26, 27, 28] | 1.0 | – | 1.3 | – | 1.5 | – | ns |
| t _{CHZ} | Clock to high Z ^[26, 27, 28] | – | 2.6 | – | 3.0 | – | 3.4 | ns |
| t _{OEV} | \overline{OE} LOW to output valid | – | 2.6 | – | 3.0 | – | 3.4 | ns |
| t _{OELZ} | \overline{OE} LOW to output low Z ^[26, 27, 28] | 0 | – | 0 | – | 0 | – | ns |
| t _{OEHZ} | \overline{OE} HIGH to output high Z ^[26, 27, 28] | – | 2.6 | – | 3.0 | – | 3.4 | ns |
| Set-up Times | | | | | | | | |
| t _{AS} | Address set-up before CLK rise | 1.2 | – | 1.4 | – | 1.5 | – | ns |
| t _{ADS} | \overline{ADSC} , \overline{ADSP} set-up before CLK rise | 1.2 | – | 1.4 | – | 1.5 | – | ns |
| t _{ADVS} | \overline{ADV} set-up before CLK rise | 1.2 | – | 1.4 | – | 1.5 | – | ns |
| t _{WES} | \overline{GW} , \overline{BWE} , \overline{BW}_X set-up before CLK rise | 1.2 | – | 1.4 | – | 1.5 | – | ns |
| t _{DS} | Data input set-up before CLK rise | 1.2 | – | 1.4 | – | 1.5 | – | ns |
| t _{CES} | Chip enable set-up before CLK rise | 1.2 | – | 1.4 | – | 1.5 | – | ns |
| Hold Times | | | | | | | | |
| t _{AH} | Address hold after CLK rise | 0.3 | – | 0.4 | – | 0.5 | – | ns |
| t _{ADH} | \overline{ADSP} , \overline{ADSC} hold after CLK rise | 0.3 | – | 0.4 | – | 0.5 | – | ns |
| t _{ADVH} | \overline{ADV} hold after CLK rise | 0.3 | – | 0.4 | – | 0.5 | – | ns |
| t _{WEH} | \overline{GW} , \overline{BWE} , \overline{BW}_X hold after CLK rise | 0.3 | – | 0.4 | – | 0.5 | – | ns |
| t _{DH} | Data input hold after CLK rise | 0.3 | – | 0.4 | – | 0.5 | – | ns |
| t _{CEH} | Chip enable hold after CLK rise | 0.3 | – | 0.4 | – | 0.5 | – | ns |

Notes

23. Timing reference level is 1.5 V when V_{DDQ} = 3.3 V and is 1.25 V when V_{DDQ} = 2.5 V.

24. Test conditions shown in (a) of AC Test Loads unless otherwise noted.

25. This part has a voltage regulator internally; t_{POWER} is the time that the power needs to be supplied above V_{DD}(minimum) initially before a read or write operation can be initiated.

26. t_{CHZ}, t_{CLZ}, t_{OELZ}, and t_{OEHZ} are specified with AC test conditions shown in (b) of AC Test Loads. Transition is measured ± 200 mV from steady-state voltage.

27. At any given voltage and temperature, t_{OEHZ} is less than t_{OELZ} and t_{CHZ} is less than t_{CLZ} to eliminate bus contention between SRAMs when sharing the same data bus. These specifications do not imply a bus contention condition, but reflect parameters guaranteed over worst case user conditions. Device is designed to achieve high Z prior to low Z under the same system conditions.

28. This parameter is sampled and not 100% tested.

Switching Waveforms (continued)

Write Cycle Timing [30, 31]

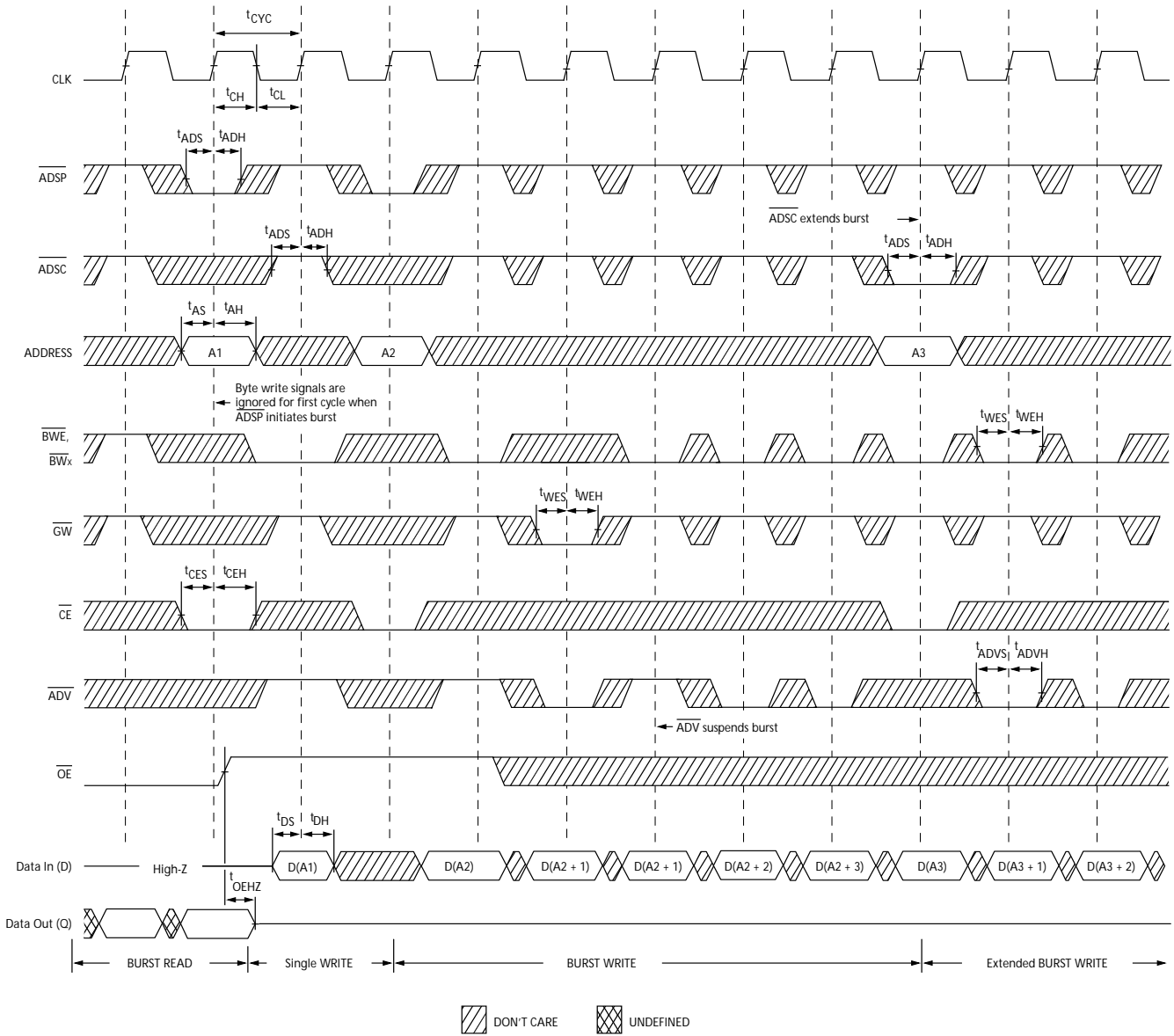

Notes

30. On this diagram, when \overline{CE} is LOW: \overline{CE}_1 is LOW, CE_2 is HIGH and \overline{CE}_3 is LOW. When \overline{CE} is HIGH: \overline{CE}_1 is HIGH or CE_2 is LOW or \overline{CE}_3 is HIGH.
 31. Full width write can be initiated by either GW LOW; or by GW HIGH, BWE LOW and BW_x LOW.

Switching Waveforms (continued)
Read/Write Cycle Timing^[32, 33, 34]

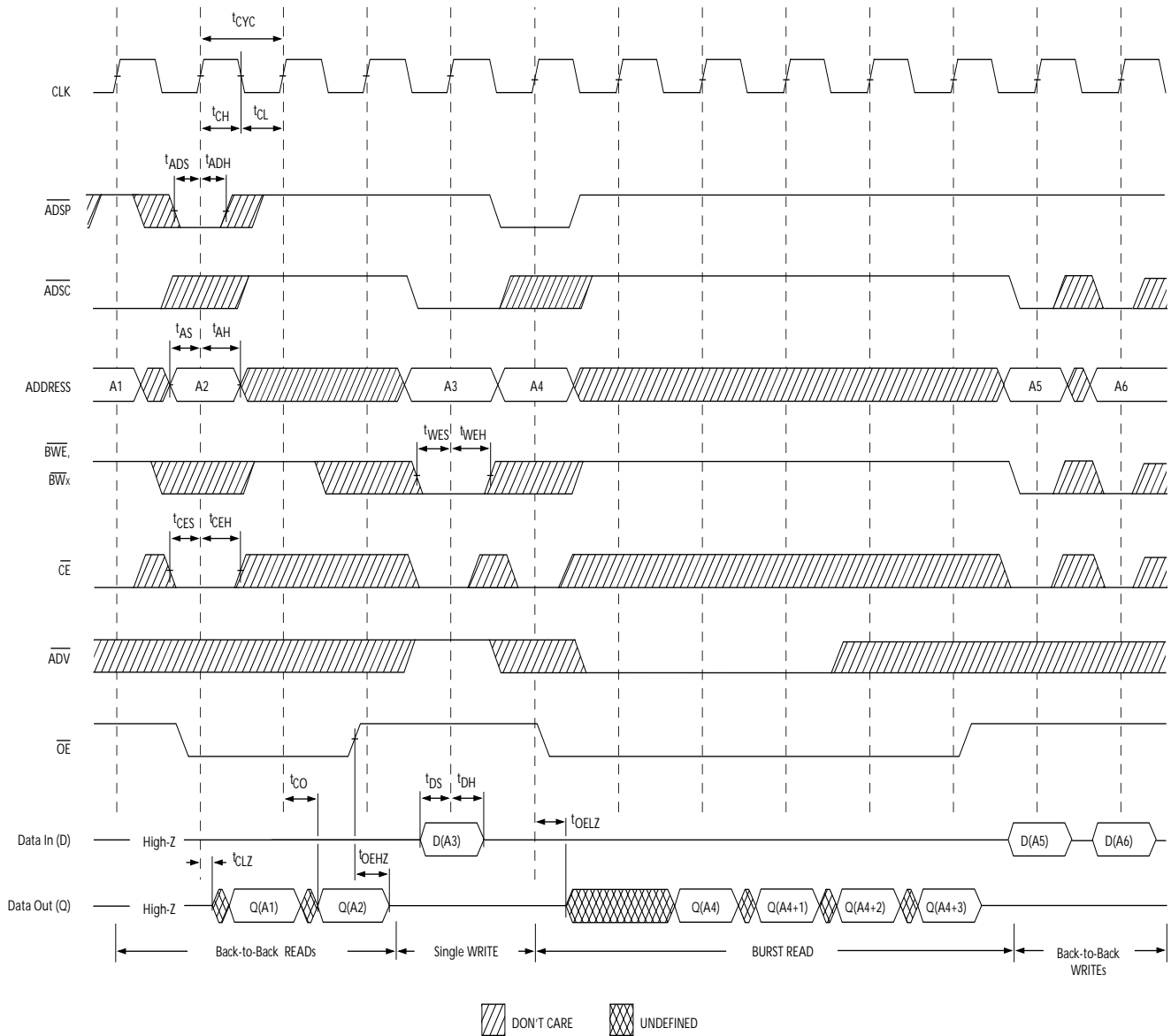

Notes

- 32. On this diagram, when \overline{CE}_1 is LOW: \overline{CE}_1 is LOW, CE_2 is HIGH and \overline{CE}_3 is LOW. When \overline{CE} is HIGH: \overline{CE}_1 is HIGH or CE_2 is LOW or \overline{CE}_3 is HIGH.
- 33. The data bus (Q) remains in high Z following a Write cycle, unless a new read access is initiated by ADSP or ADSC.
- 34. GW is HIGH.

Switching Waveforms (continued)

ZZ Mode Timing^[35, 36]

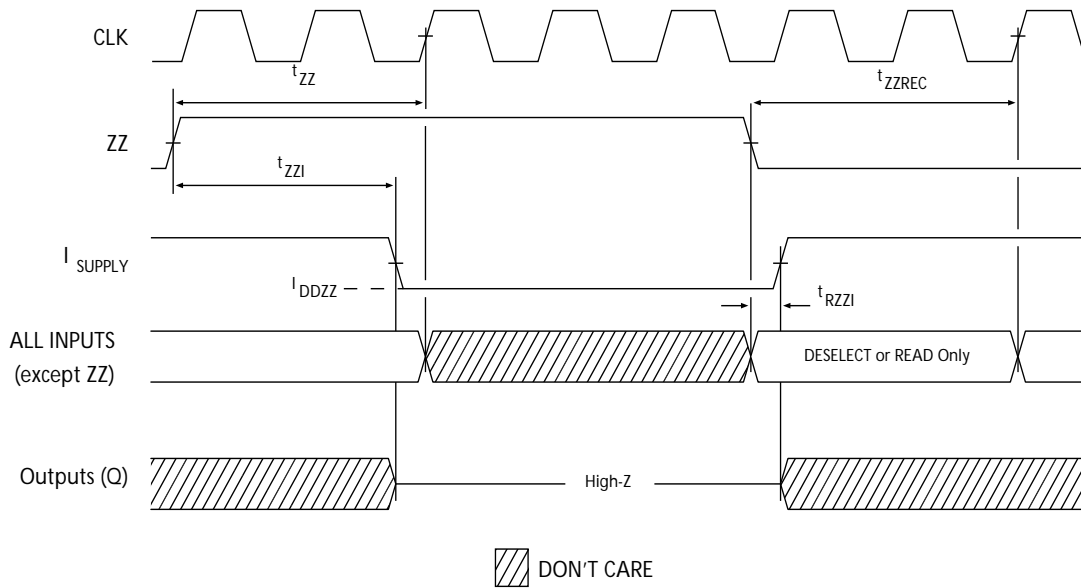

Notes

- 35. Device must be deselected when entering ZZ mode. See Cycle Descriptions table for all possible signal conditions to deselect the device.
- 36. DQs are in high Z when exiting ZZ sleep mode.

Ordering Information

Cypress offers other versions of this type of product in different configurations and features. The following table contains only the list of parts that are currently available.

For a complete listing of all options, visit the Cypress website at www.cypress.com and refer to the product summary page at <http://www.cypress.com/products>, or contact your local sales representative.

Cypress maintains a worldwide network of offices, solution centers, manufacturer's representatives and distributors. To find the office closest to you, visit us at <http://www.cypress.com/go/datasheet/offices>.

| Speed (MHz) | Ordering Code | Package Diagram | Part and Package Type | Operating Range |
|-------------|---------------------|-----------------|--|-----------------|
| 167 | CY7C1440AV33-167AXC | 51-85050 | 100-pin Thin Quad Flat Pack (14 x 20 x 1.4 mm) Pb-free | Commercial |
| 250 | CY7C1440AV33-250AXC | 51-85050 | 100-pin Thin Quad Flat Pack (14 x 20 x 1.4 mm) Pb-free | Commercial |
| | CY7C1440AV33-250AXI | 51-85050 | 100-pin Thin Quad Flat Pack (14 x 20 x 1.4 mm) Pb-free | Industrial |

Ordering Code Definitions

CY7C 1440 A V33 - XXX XX X

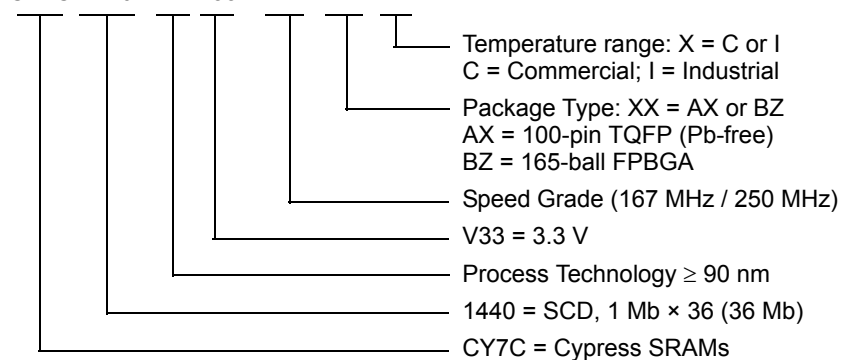

Package Diagrams

100-pin TQFP (14 × 20 × 1.4 mm), 51-85050

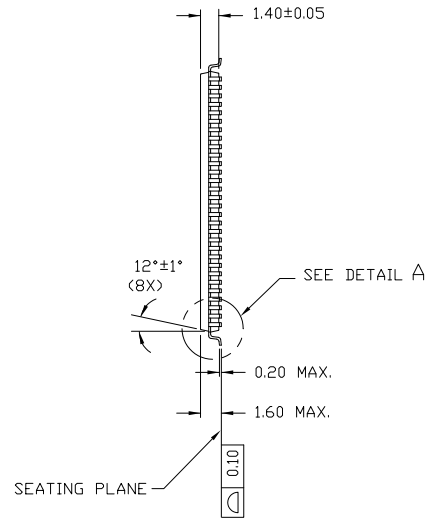
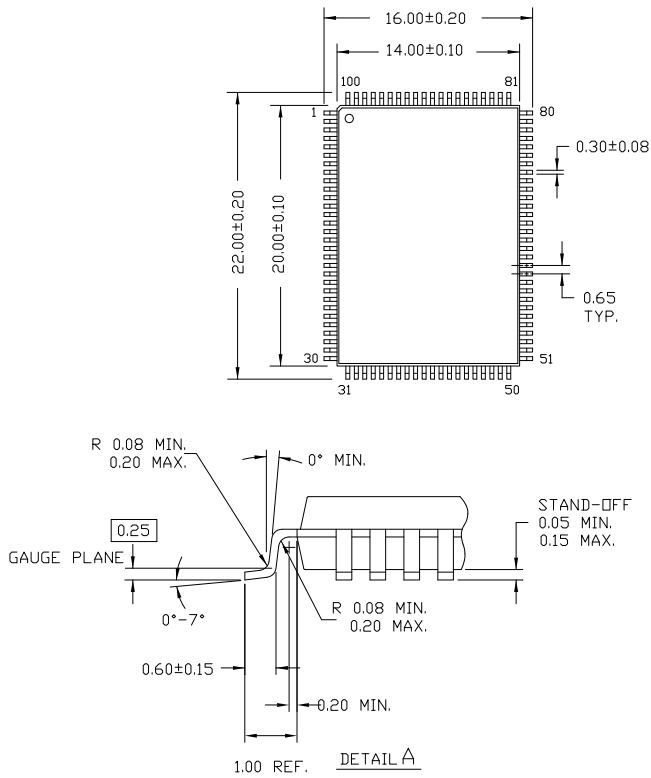

NOTE:

1. JEDEC STD REF MS-026
2. BODY LENGTH DIMENSION DOES NOT INCLUDE MOLD PROTRUSION/END FLASH
MOLD PROTRUSION/END FLASH SHALL NOT EXCEED 0.0098 in (0.25 mm) PER SIDE
BODY LENGTH DIMENSIONS ARE MAX PLASTIC BODY SIZE INCLUDING MOLD MISMATCH
3. DIMENSIONS IN MILLIMETERS

51-85050 *C

Package Diagrams (continued)

165-ball FBGA (15 × 17 × 1.4 mm), 51-85165

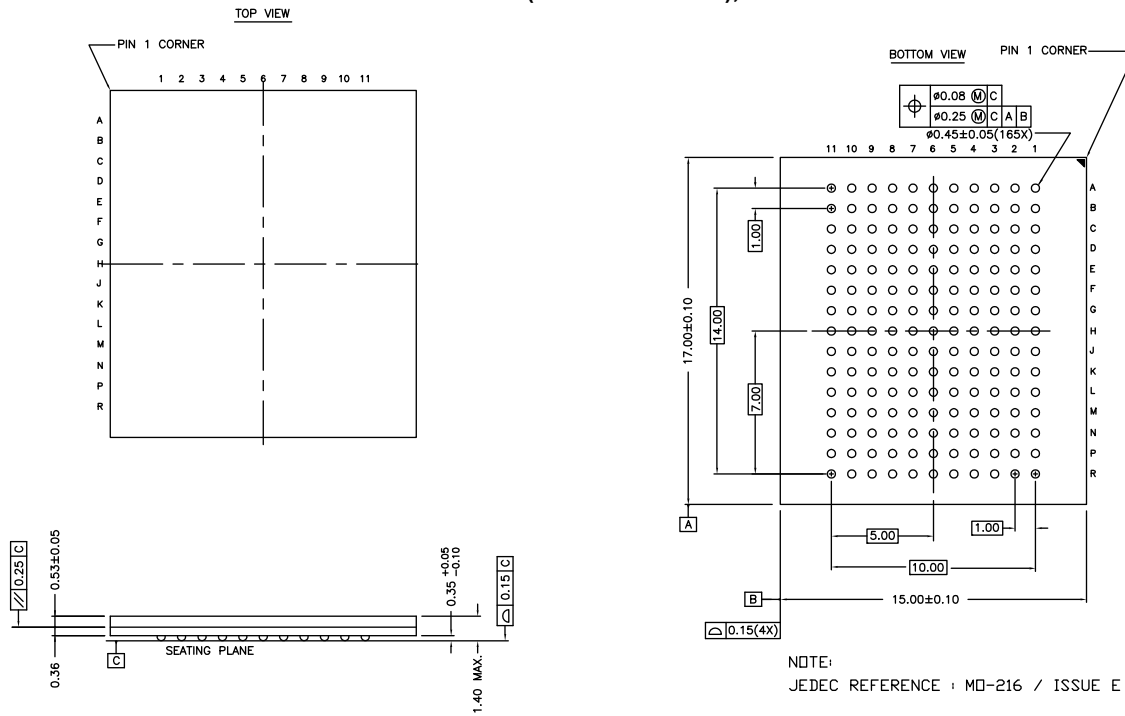

51-85165 *B

Package Diagrams (continued)

209-ball FBGA (14 × 22 × 1.76 mm), 51-85167

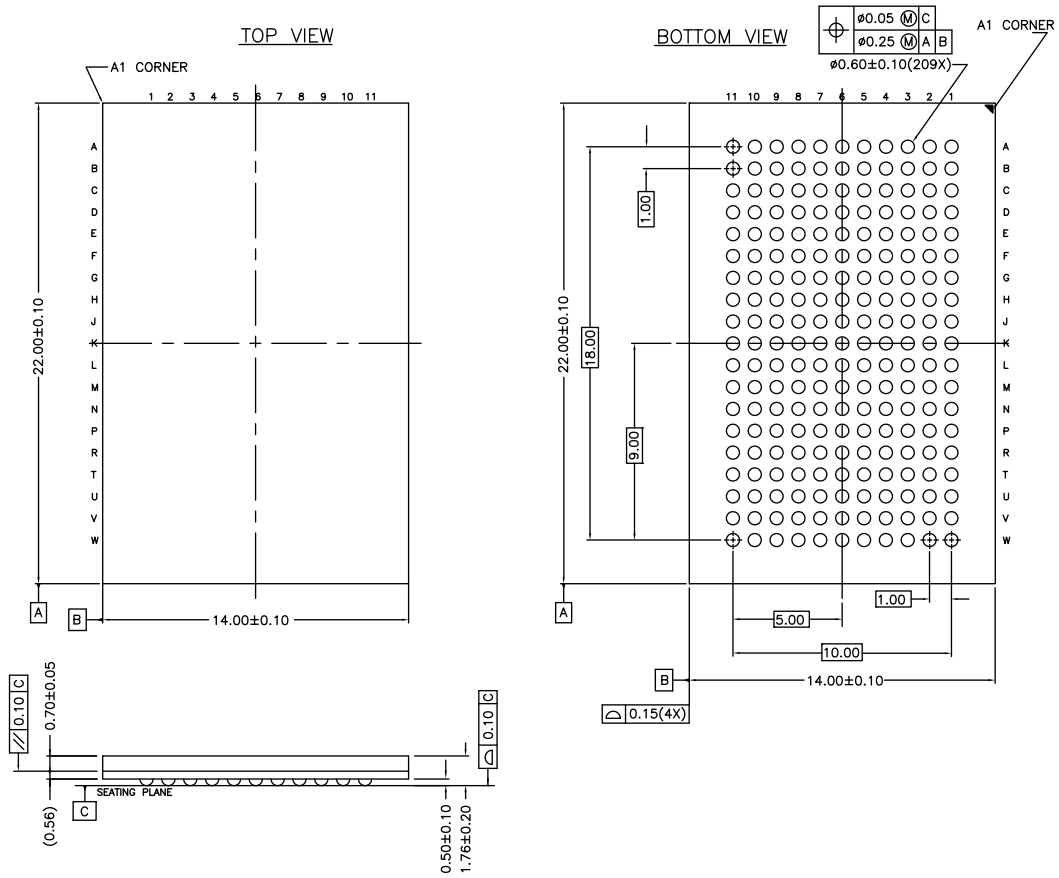

51-85167 *A

Acronyms

| Acronym | Description |
|---------|---|
| CE | chip enable |
| CEN | clock enable |
| CMOS | complementary metal oxide semiconductor |
| FPBGA | fine-pitch ball grid array |
| I/O | input/output |
| JTAG | Joint Test Action Group |
| NoBL | No Bus Latency |
| OE | output enable |
| SRAM | static random access memory |
| TCK | test clock |
| TMS | test mode select |
| TDI | test data-in |
| TDO | test data-out |
| TQFP | thin quad flat pack |
| WE | write enable |

Document Conventions

Units of Measure

| Symbol | Unit of Measure |
|--------|-----------------|
| ns | nano seconds |
| V | Volts |
| μA | micro Amperes |
| mA | milli Amperes |
| ms | milli seconds |
| mm | milli meter |
| MHz | Mega Hertz |
| pF | pico Farad |
| W | Watts |
| °C | degree Celcius |

Document History Page

| Document Title: CY7C1440AV33/CY7C1442AV33/CY7C1446AV33 36-Mbit (1 M × 36/2 M × 18/512 K × 72) Pipelined Sync SRAM | | | | |
|---|---------|------------|-----------------|---|
| Document Number: 38-05383 | | | | |
| REV. | ECN NO. | Issue Date | Orig. of Change | Description of Change |
| ** | 124437 | 03/04/03 | CJM | New data sheet |
| *A | 254910 | See ECN | SYT | Part number changed from previous revision. New and old part number differ by the letter "A" Modified Functional Block diagrams Modified switching waveforms Added Boundary scan information Added Footnote #14 (32-Bit Vendor ID Code changed) Added I _{DD} , I _X and I _{SB} values in the DC Electrical Characteristics Added t _{POWER} specifications in Switching Characteristics table Removed 119 PBGA package Changed 165 FBGA package from BB165C (15 x 17 x 1.20 mm) to BB165 (15 x 17 x 1.40 mm) Changed 209-Lead PBGA BG209 (14 x 22 x 2.20 mm) to BB209A (14 x 22 x 1.76 mm) |
| *B | 306335 | See ECN | SYT | Changed H9 pin from V _{SSQ} to V _{SS} on the Pin Configuration table for 209 FBGA on Page # 6 Changed t _{CO} from 3.0 to 3.2 ns and t _{DOH} from 1.3 ns to 1.5 ns for 200 Mhz speed bin on the Switching Characteristics table on Page # 19 Changed Θ_{JA} and Θ_{JC} from TBD to 25.21 and 2.58 °C/W respectively for TQFP Package on Pg # 19 Replaced Θ_{JA} and Θ_{JC} from TBD to respective Values for 165 BGA and 209 FBGA Packages on the Thermal Resistance Table Added lead-free information for 100-pin TQFP, 165 FBGA and 209 FBGA Packages Changed I _{DD} from 450, 400 and 350 mA to 475, 425 and 375 mA for frequencies of 250, 200 and 167 MHz respectively Changed I _{SB1} from 190, 180 and 170 mA to 225 mA for frequencies of 250, 200 and 167 MHz respectively Changed I _{SB2} from 80 to 100 mA Changed I _{SB3} from 180, 170 and 160 mA to 200 mA for frequencies of 250, 200 and 167 MHz respectively Changed I _{SB4} from 100 to 110 mA |
| *C | 332173 | See ECN | SYT | Modified Address Expansion balls in the pinouts for 165 FBGA and 209 FBGA Package as per JEDEC standards Modified V _{OL} , V _{OH} test conditions Changed C _{IN} , C _{CLK} and C _{I/O} to 7, 7 and 6 pF from 5, 5 and 7 pF for 165 FBGA Package Changed I _{SB2} and I _{SB4} from 100 and 110 mA to 120 and 135 mA respectively Added Industrial Temperature Grade Included the missing 100 TQFP Package Diagram Updated the Ordering Information by Shading and Unshading MPNs as per availability |

Document Title: CY7C1440AV33/CY7C1442AV33/CY7C1446AV33 36-Mbit (1 M × 36/2 M × 18/512 K × 72) Pipelined Sync SRAM
Document Number: 38-05383

| REV. | ECN NO. | Issue Date | Orig. of Change | Description of Change |
|------|---------|------------|-----------------|--|
| *D | 417547 | See ECN | RXU | <p>Converted from Preliminary to Final</p> <p>Changed address of Cypress Semiconductor Corporation on Page# 1 from "3901 North First Street" to "198 Champion Court"</p> <p>Changed I_X current value in MODE from -5 & 30 μA to -30 & 5 μA respectively and also Changed I_X current value in ZZ from -30 & 5 μA to -5 & 30 μA respectively on page# 18</p> <p>Modified test condition in note# 8 from $V_{IH} \leq V_{DD}$ to $V_{IH} < V_{DD}$</p> <p>Modified "Input Load" to "Input Leakage Current except ZZ and MODE" in the Electrical Characteristics Table</p> <p>Replaced Package Name column with Package Diagram in the Ordering Information table</p> <p>Replaced Package Diagram of 51-85050 from *A to *B</p> <p>Updated the Ordering Information</p> |
| *E | 473650 | See ECN | VKN | <p>Added the Maximum Rating for Supply Voltage on V_{DDQ} Relative to GND.</p> <p>Changed t_{TH}, t_{TL} from 25 ns to 20 ns and t_{DOV} from 5 ns to 10 ns in TAP AC Switching Characteristics table.</p> <p>Updated the Ordering Information table.</p> |
| *F | 2897278 | 03/22/2010 | NJY | <p>Removed obsolete part numbers from Ordering Information table and updated package diagrams.</p> |
| *G | 3044512 | 10/01/2010 | NJY | <p>Added Ordering Code Definitions.</p> <p>Added Acronyms and Units of Measure.</p> <p>Minor edits and updated in new template.</p> |
| *H | 3055212 | 10/11/2010 | NJY | <p>Updated Ordering Information.</p> |

Sales, Solutions, and Legal Information

Worldwide Sales and Design Support

Cypress maintains a worldwide network of offices, solution centers, manufacturer's representatives, and distributors. To find the office closest to you, visit us at [Cypress Locations](#).

Products

| | |
|--|--|
| Automotive | cypress.com/go/automotive |
| Clocks & Buffers | cypress.com/go/clocks |
| Interface | cypress.com/go/interface |
| Lighting & Power Control | cypress.com/go/powerpsoc cypress.com/go/plc |
| Memory | cypress.com/go/memory |
| Optical & Image Sensing | cypress.com/go/image |
| PSoC | cypress.com/go/psoc |
| Touch Sensing | cypress.com/go/touch |
| USB Controllers | cypress.com/go/USB |
| Wireless/RF | cypress.com/go/wireless |

PSoC Solutions

psoc.cypress.com/solutions
PSoC 1 | PSoC 3 | PSoC 5

© Cypress Semiconductor Corporation, 2006-2010. The information contained herein is subject to change without notice. Cypress Semiconductor Corporation assumes no responsibility for the use of any circuitry other than circuitry embodied in a Cypress product. Nor does it convey or imply any license under patent or other rights. Cypress products are not warranted nor intended to be used for medical, life support, life saving, critical control or safety applications, unless pursuant to an express written agreement with Cypress. Furthermore, Cypress does not authorize its products for use as critical components in life-support systems where a malfunction or failure may reasonably be expected to result in significant injury to the user. The inclusion of Cypress products in life-support systems application implies that the manufacturer assumes all risk of such use and in doing so indemnifies Cypress against all charges.



Any Source Code (software and/or firmware) is owned by Cypress Semiconductor Corporation (Cypress) and is protected by and subject to worldwide patent protection (United States and foreign), United States copyright laws and international treaty provisions. Cypress hereby grants to licensee a personal, non-exclusive, non-transferable license to copy, use, modify, create derivative works of, and compile the Cypress Source Code and derivative works for the sole purpose of creating custom software and or firmware in support of licensee product to be used only in conjunction with a Cypress integrated circuit as specified in the applicable agreement. Any reproduction, modification, translation, compilation, or representation of this Source Code except as specified above is prohibited without the express written permission of Cypress.

Disclaimer: CYPRESS MAKES NO WARRANTY OF ANY KIND, EXPRESS OR IMPLIED, WITH REGARD TO THIS MATERIAL, INCLUDING, BUT NOT LIMITED TO, THE IMPLIED WARRANTIES OF MERCHANTABILITY AND FITNESS FOR A PARTICULAR PURPOSE. Cypress reserves the right to make changes without further notice to the materials described herein. Cypress does not assume any liability arising out of the application or use of any product or circuit described herein. Cypress does not authorize its products for use as critical components in life-support systems where a malfunction or failure may reasonably be expected to result in significant injury to the user. The inclusion of Cypress' product in a life-support systems application implies that the manufacturer assumes all risk of such use and in doing so indemnifies Cypress against all charges.

Use may be limited by and subject to the applicable Cypress software license agreement.

Looking for pricing, stock, or lifecycle information?

Click below to explore more details on WIN SOURCE:

-  [View CY7C1440AV33-167BZC on WIN SOURCE](#)
-  [Cypress Semiconductor Corp Information](#)

Optimize Your Supply Chain with WIN SOURCE Solutions

-  Global Sourcing Solution
-  Obsolete Management
-  Cost Control Management
-  Shortage Management
-  Alternative Solution
-  Excess Inventory Management