

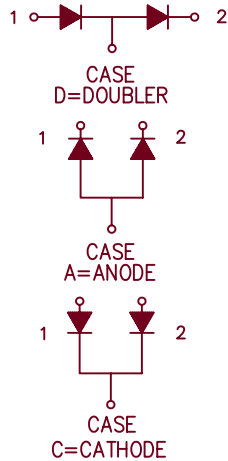

# THE DATASHEET OF SD241

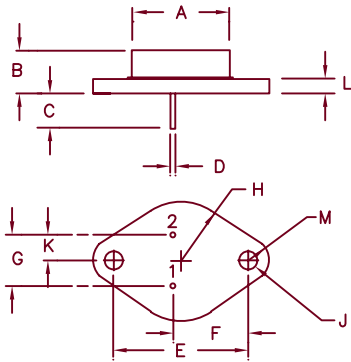

# Schottky Rectifier SD241, SD24145



Dim.	Inches		Millimeter		Notes
	Minimum	Maximum	Minimum	Maximum	
A	—	.875	—	22.23	Dia.
B	.250	.450	6.35	11.43	
C	.435	—	11.05	—	
D	.038	.043	.97	1.09	Dia.
E	1.177	1.197	29.90	30.40	
F	.655	.675	16.64	17.15	
G	.420	.440	10.67	11.18	
H	—	.525	—	13.34	Rad.
J	.151	.161	3.84	4.09	Dia.
K	.205	.225	5.21	5.72	
L	—	.135	—	3.43	
M	—	.188	—	4.78	Rad.

TO-204AA (TO-3)

Microsemi Catalog Number	Working Peak Reverse Voltage	Repetitive Peak Reverse Voltage
SD241*	35V	35V
SD24145*	45V	45V

\*ADD D, C, or A

- Schottky Barrier Rectifier
- Guard Ring Protection
- Low Forward Voltage
- $V_{RRM}$  - 35 & 45V
- 30 Amperes
- Reverse Energy Tested

## Electrical Characteristics Per Leg

Average forward current (standard)	$I_{F(AV)}$ 30 Amps	$T_C = 148^\circ\text{C}$ , Square wave, $R_{\theta JC} = 1.4^\circ\text{C/W}$
Average forward current (reverse)	$I_{F(AV)}$ 30 Amps	$T_C = 132^\circ\text{C}$ , Square wave, $R_{\theta JC} = 2.2^\circ\text{C/W}$
Maximum surge current	$I_{FSM}$ 600 Amps	8.3 ms, half sine $T_J = 175^\circ\text{C}$
Max repetitive peak reverse current	$I_{R(OV)}$ 2 Amps	$f = 1 \text{ KHz}$ , $25^\circ\text{C}$ , 1 $\mu\text{sec}$ Square wave
Max peak forward voltage	$V_{FM}$ .57 Volts	$I_{FM} = 30\text{A}$ ; $T_J = 175^\circ\text{C}^*$
Max peak forward voltage	$V_{FM}$ .70 Volts	$I_{FM} = 30\text{A}$ ; $T_J = 25^\circ\text{C}^*$
Max peak reverse current	$I_{RM}$ 25 mA	$V_{RRM}$ , $T_J = 125^\circ\text{C}^*$
Max peak reverse current	$I_{RM}$ 1.5 mA	$V_{RRM}$ , $T_J = 25^\circ\text{C}$
Typical junction capacitance per leg	$C_J$ 1350 pF	$V_R = 5.0\text{V}$ , $T_J = 25^\circ\text{C}$

\*Pulse test: Pulse width 300  $\mu\text{sec}$ , Duty cycle 2%

## Thermal and Mechanical Characteristics

Storage temp range	$T_{STG}$	$-65^\circ\text{C}$ to $175^\circ\text{C}$
Operating junction temp range	$T_J$	$-65^\circ\text{C}$ to $175^\circ\text{C}$
Maximum thermal resistance (standard polarity)	$R_{\theta JC}$	$1.4^\circ\text{C/W}$ Junction to case
Maximum thermal resistance (reverse polarity)	$R_{\theta JC}$	$2.2^\circ\text{C/W}$ Junction to case
Typical thermal resistance (greased)	$R_{\theta CS}$	$0.5^\circ\text{C/W}$ Case to sink
Weight		1.0 ounces (28 grams) typical



6 Lake Street  
Lawrence, MA 01841  
PH: (978) 620-2600  
FAX: (978) 689-0803  
www.microsemi.com

05-30-07 Rev. 2

# SD241, SD24145

Figure 1  
Typical Forward Characteristics

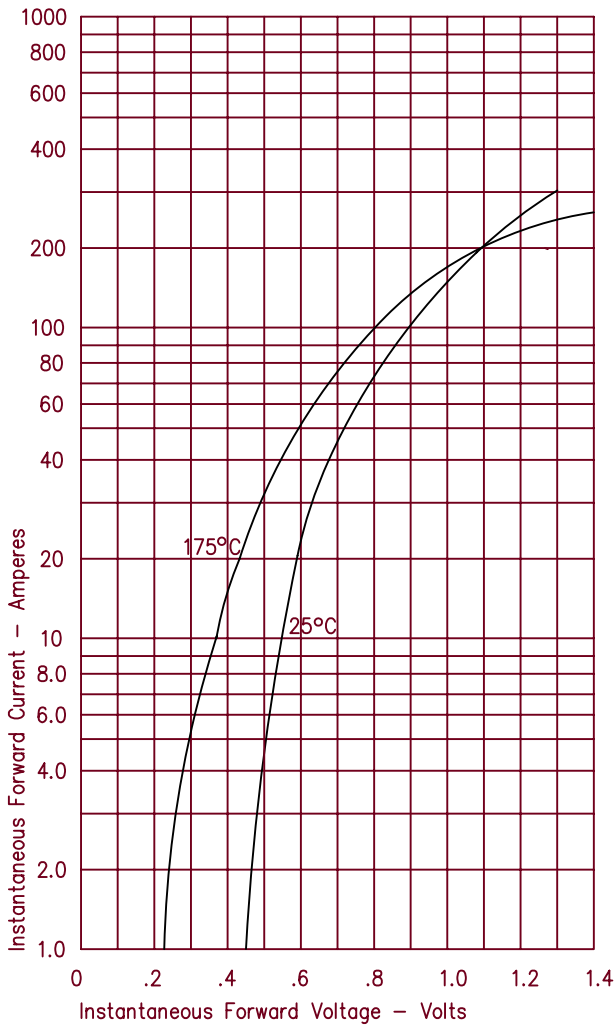

Figure 3  
Typical Junction Capacitance

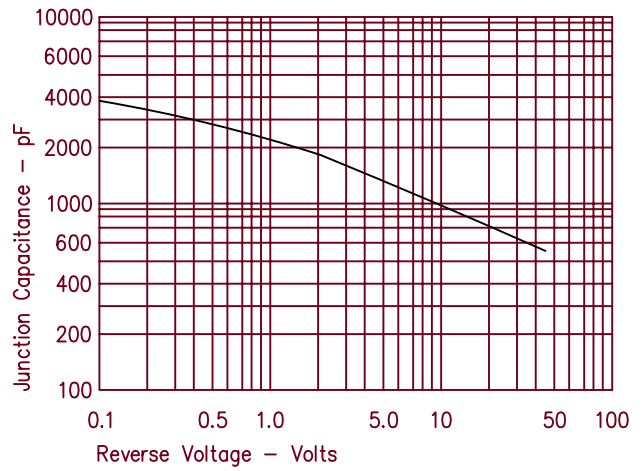

Figure 4  
Forward Current Derating - Standard Polarity

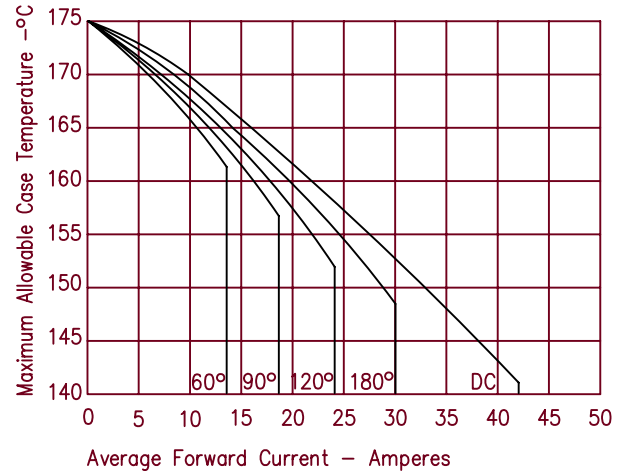

Figure 2  
Typical Reverse Characteristics

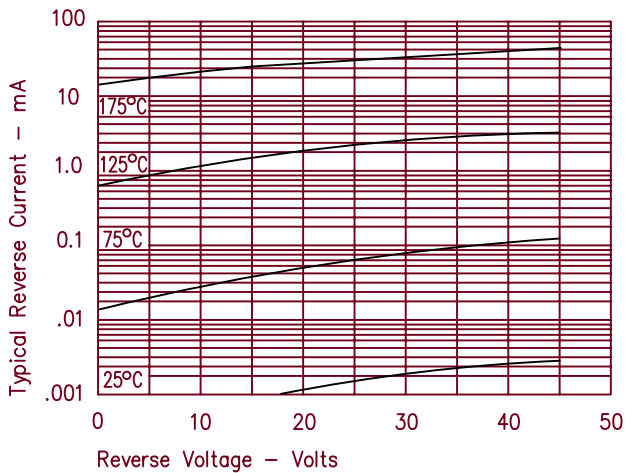
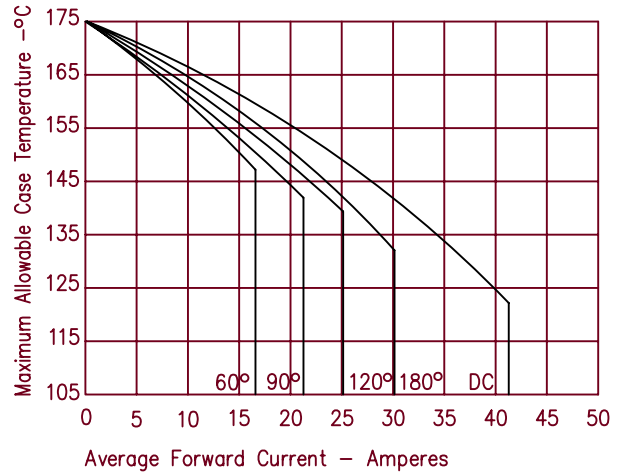

Figure 5  
Forward Current Derating - Reverse Polarity



# SD241, SD24145

Figure 6  
Maximum Forward Power Dissipation – Standard Polarity

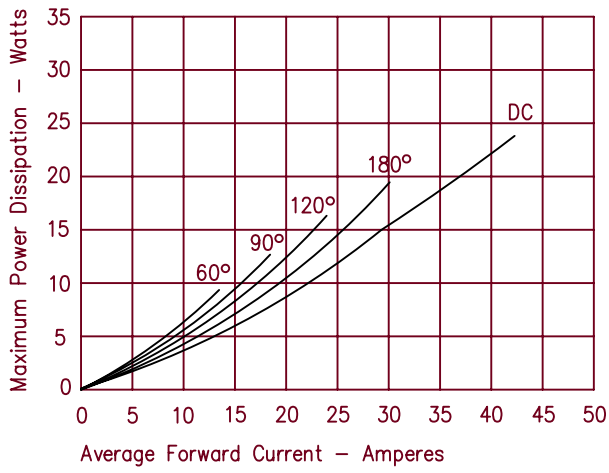
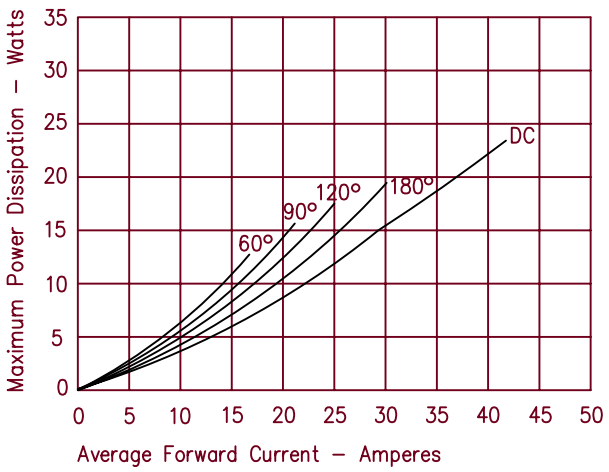



Figure 7  
Maximum Forward Power Dissipation – Reverse Polarity



## Looking for pricing, stock, or lifecycle information?

Click below to explore more details on WIN SOURCE:

-  [View SD241](#) on WIN SOURCE
-  [Microchip Technology](#) Information

## Optimize Your Supply Chain with WIN SOURCE Solutions

-  Global Sourcing Solution
-  Obsolete Management
-  Cost Control Management
-  Shortage Management
-  Alternative Solution
-  Excess Inventory Management