

THS309x High-voltage, Low-distortion, Current-feedback Operational Amplifiers

1 Features

- Low Distortion
 - 77-dBc HD2 at 10 MHz, $R_L = 1\text{ k}\Omega$
 - 69-dBc HD3 at 10 MHz, $R_L = 1\text{ k}\Omega$
- Low Noise
 - 14-pA/ $\sqrt{\text{Hz}}$ Noninverting Current Noise
 - 17-pA/ $\sqrt{\text{Hz}}$ Inverting Current Noise
 - 2-nV/ $\sqrt{\text{Hz}}$ Voltage Noise
- High Slew Rate: 7300 V/ μs ($G = 5$, $V_O = 20\text{ V}_{PP}$)
- Wide Bandwidth: 210 MHz ($G = 2$, $R_L = 100\ \Omega$)
- High Output Current Drive: $\pm 250\text{ mA}$
- Wide Supply Range: $\pm 5\text{ V}$ to $\pm 15\text{ V}$
- Power-Down Feature: THS3095 Only

2 Applications

- High-Voltage Arbitrary Waveform Generators
- Power FET Drivers
- Pin Drivers
- VDSL Line Drivers

3 Description

The THS3091 and THS3095 are high-voltage, low-distortion, high-speed, current-feedback amplifier designed to operate over a wide supply range of $\pm 5\text{ V}$ to $\pm 15\text{ V}$ for applications requiring large, linear output signals such as Pin, Power FET, and VDSL line drivers.

The THS3095 features a power-down pin ($\overline{\text{PD}}$) that puts the amplifier in low power standby mode, and lowers the quiescent current from 9.5 mA to 500 μA .

The wide supply range combined with total harmonic distortion as low as -69 dBc at 10 MHz, in addition, to the high slew rate of 7300 V/ μs makes the THS309x ideally suited for high-voltage arbitrary waveform driver applications. Moreover, having the ability to handle large voltage swings driving into high-resistance and high-capacitance loads while maintaining good settling time performance makes the devices ideal for Pin driver and Power FET driver applications.

The THS3091 and THS3095 are offered in an 8-pin SOIC (D), and the 8-pin SOIC (DDA) packages with PowerPAD™.

Device Information⁽¹⁾

PART NUMBER	PACKAGE	BODY SIZE (NOM)
THS309x	SOIC(8)	4.90 mm x 3.91 mm
	SO PowerPAD(8)	4.89 mm x 3.90 mm

(1) For all available packages, see the orderable addendum at the end of the data sheet.

Typical Arbitrary Waveform Generator Output Drive Circuit

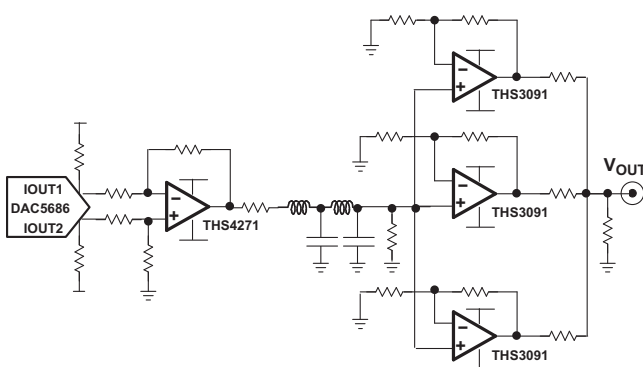

Total Harmonic Distortion vs Frequency

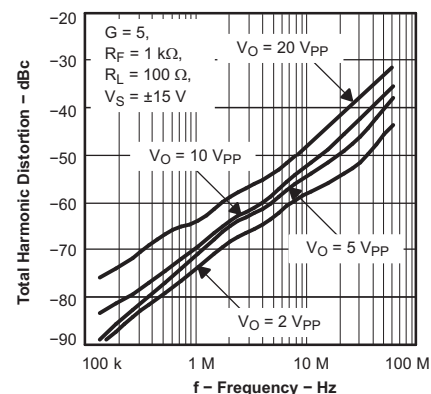

Table of Contents

1 Features 1 2 Applications 1 3 Description 1 4 Revision History 2 5 Pin Configuration and Functions 3 6 Specifications 4 6.1 Absolute Maximum Ratings 4 6.2 ESD Ratings 4 6.3 Recommended Operating Conditions 4 6.4 Thermal Information 4 6.5 Electrical Characteristics THS3091 5 6.6 Electrical Characteristics THS3095 8 6.7 Dissipation Ratings Table 11 6.8 Typical Characteristics 12 6.9 Typical Characteristics (± 15 V) 14 6.10 Typical Characteristics (± 5 V) 21 7 Detailed Description 25 7.1 Overview 25 7.2 Feature Description 25	7.3 Device Functional Modes 26 8 Application and Implementation 29 8.1 Application Information 29 8.2 Typical Application 32 9 Power Supply Recommendations 37 10 Layout 37 10.1 Layout Guidelines 37 10.2 Layout Example 38 10.3 PowerPAD Design Considerations 41 11 Device and Documentation Support 43 11.1 Device Support 43 11.2 Documentation Support 43 11.3 Related Links 43 11.4 Community Resources 43 11.5 Trademarks 44 11.6 Electrostatic Discharge Caution 44 11.7 Glossary 44 12 Mechanical, Packaging, and Orderable Information 44
---------------------------------------------------------------------------------------------------------------------------------------------------------------------------------------------------------------------------------------------------------------------------------------------------------------------------------------------------------------------------------------------------------------------------------------------------------------------------------------------------------------------------------------------------------------------------------------------------------------------------------------------------------------------------------------------------------------------------------------------------------------------------------------	--------------------------------------------------------------------------------------------------------------------------------------------------------------------------------------------------------------------------------------------------------------------------------------------------------------------------------------------------------------------------------------------------------------------------------------------------------------------------------------------------------------------------------------------------------------------------------------------------------------------------------------------------------------------------------------------------------------------------------------------------------

4 Revision History

NOTE: Page numbers for previous revisions may differ from page numbers in the current version.

Changes from Revision G (February, 2007) to Revision H	Page
<ul style="list-style-type: none"> • Added Added <i>ESD Ratings</i> table, <i>Feature Description</i> section, <i>Device Functional Modes</i>, <i>Application and Implementation</i> section, <i>Power Supply Recommendations</i> section, <i>Layout</i> section, <i>Device and Documentation Support</i> section, and <i>Mechanical, Packaging, and Orderable Information</i> section. 	1

Changes from Revision F (February, 2007) to Revision G	Page
<ul style="list-style-type: none"> • Changed common-mode rejection ratio specifications from 78 dB (typ) to 69 dB (typ); from 68 dB at +25°C to 62 dB; from 65 dB at (0°C to +70°C) and (–40°C to +85°C) to 59 dB. • Corrected load resistor value for output current specification (sourcing and sinking) from $R_L = 40 \Omega$ to $R_L = 10 \Omega$ 10 • Changed output current (sourcing) specifications from 200 mA (typ) to 180 mA (typ); from 160 mA at +25°C to 140 mA; from 140 mA at (0°C to +70°C) and (–40°C to +85°C) to 120 mA 10 • Corrected output current (sinking) specifications from 180 mA (typ) to –160 mA (typ); from 150 mA at +25°C to –140 mA; from 125 mA at (0°C to +70°C) and (–40°C to +85°C) to –120 mA 10 	10

5 Pin Configuration and Functions

D, DDA Package (THS3091)
8-Pin SOIC With PowerPAD
 Top View

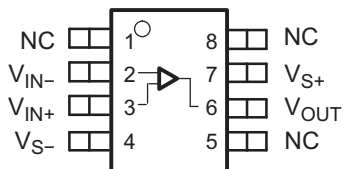

D, DDA Package (THS3095)
8-Pin SOIC With PowerPAD
 Top View

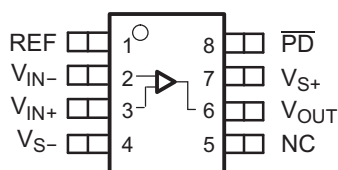

Pin Functions⁽¹⁾

PIN			I/O	DESCRIPTION
NAME	SOIC	SOT-23		
THS3091				
NC	1	—	—	No connection
	5			
	8			
V _{in-}	2	4	I	Inverting input
V _{in+}	3	3	I	Noninverting input
-V _s	4	2	POW	Negative power supply
V _{out}	6	1	O	Output of amplifier
+V _s	7	5	POW	Positive power supply
THS3095				
NC	5	—	—	No connection
$\overline{\text{PD}}$	8	—	I	Amplifier power down, LOW - Amplifier disabled, HIGH (default) - Amplifier enabled
REF	1	—	I	Voltage reference input to set $\overline{\text{PD}}$ threshold level
V _{in-}	2	4	I	Inverting input
V _{in+}	3	3	I	Noninverting input
V _{out}	6	1	O	Output of amplifier
-V _s	4	2	POW	Negative power supply
+V _s	7	5	POW	Positive power supply

(1) NC – No internal connection

6 Specifications

6.1 Absolute Maximum Ratings

 over operating free-air temperature range (unless otherwise noted)⁽¹⁾

		MIN	MAX	UNIT
V_{S-} to V_{S+}	Supply voltage		33	V
V_I	Input voltage			$\pm V_S$
V_{ID}	Differential input voltage		4	$\pm V$
I_O	Output current		350	mA
	Continuous power dissipation	See ESD Ratings		
T_J	Maximum junction temperature		150	°C
$T_J^{(2)}$	Maximum junction temperature, continuous operation, long-term reliability		125	°C
T_{stg}	Storage temperature	-65	150	°C

- (1) Stresses beyond those listed under *Absolute Maximum Ratings* may cause permanent damage to the device. These are stress ratings only, which do not imply functional operation of the device at these or any other conditions beyond those indicated under *Recommended Operating Conditions*. Exposure to absolute-maximum-rated conditions for extended periods may affect device reliability.
- (2) The maximum junction temperature for continuous operation is limited by package constraints. Operation above this temperature may result in reduced reliability and/or lifetime of the device.

6.2 ESD Ratings

		VALUE	UNIT
$V_{(ESD)}$	Electrostatic discharge	Human-body model (HBM), per ANSI/ESDA/JEDEC JS-001 ⁽¹⁾	± 2000
		Charged-device model (CDM), per JEDEC specification JESD22-C101 ⁽²⁾	± 1500

- (1) JEDEC document JEP155 states that 500-V HBM allows safe manufacturing with a standard ESD control process.
- (2) JEDEC document JEP157 states that 250-V CDM allows safe manufacturing with a standard ESD control process.

6.3 Recommended Operating Conditions

over operating free-air temperature range (unless otherwise noted)

		MIN	NOM	MAX	UNIT
Supply voltage	Dual supply	± 5	± 15	± 16	V
	Single supply	10	30	32	
T_A	Operating free-air temperature	-40		85	°C

6.4 Thermal Information

THERMAL METRIC ⁽¹⁾	THS309x		UNIT	
	D (SOIC)	DDA (SO PowerPAD) ⁽²⁾		
	8 PINS	8 PINS		
$R_{\theta JA}$	Junction-to-ambient thermal resistance	113.5	51.8	°C/W
$R_{\theta JC(top)}$	Junction-to-case (top) thermal resistance	57.7	58.3	°C/W
$R_{\theta JB}$	Junction-to-board thermal resistance	54.2	32.3	°C/W
Ψ_{JT}	Junction-to-top characterization parameter	11.5	12.2	°C/W
Ψ_{JB}	Junction-to-board characterization parameter	53.7	32.2	°C/W
$R_{\theta JC(bot)}$	Junction-to-case (bottom) thermal resistance	n/a	7.8	°C/W

- (1) For more information about traditional and new thermal metrics, see the *Semiconductor and IC Package Thermal Metrics* application report, [SPRA953](#).
- (2) The THS3091 and THS3095 may incorporate a PowerPAD on the underside of the chip. This acts as a heatsink and must be connected to a thermally dissipating plane for proper power dissipation. Failure to do so may result in exceeding the maximum junction temperature which could permanently damage the device. See TI Technical Brief [SLMA002](#) for more information about utilizing the PowerPAD thermally enhanced package.

6.5 Electrical Characteristics THS3091

 $V_S = \pm 15\text{ V}$, $R_F = 1.21\text{ k}\Omega$, $R_L = 100\ \Omega$, and $G = 2$ (unless otherwise noted)

PARAMETER	TEST CONDITIONS		MIN	TYP	MAX	UNIT
AC PERFORMANCE						
Small-signal bandwidth, -3 dB	$G = 1$, $R_F = 1.78\text{ k}\Omega$, $V_O = 200\text{ mV}_{PP}$	$T_A = 25^\circ\text{C}$		235		MHz
	$G = 2$, $R_F = 1.21\text{ k}\Omega$, $V_O = 200\text{ mV}_{PP}$	$T_A = 25^\circ\text{C}$		210		
	$G = 5$, $R_F = 1\text{ k}\Omega$, $V_O = 200\text{ mV}_{PP}$	$T_A = 25^\circ\text{C}$		190		
	$G = 10$, $R_F = 866\ \Omega$, $V_O = 200\text{ mV}_{PP}$	$T_A = 25^\circ\text{C}$		180		
0.1-dB Bandwidth flatness	$G = 2$, $R_F = 1.21\text{ k}\Omega$, $V_O = 200\text{ mV}_{PP}$	$T_A = 25^\circ\text{C}$		95		
Large-signal bandwidth	$G = 5$, $R_F = 1\text{ k}\Omega$, $V_O = 4\text{ V}_{PP}$	$T_A = 25^\circ\text{C}$		135		
Slew rate (25% to 75% level)	$G = 2$, $V_O = 10\text{-V step}$, $R_F = 1.21\text{ k}\Omega$	$T_A = 25^\circ\text{C}$		5000		V/ μs
	$G = 5$, $V_O = 20\text{-V step}$, $R_F = 1\text{ k}\Omega$	$T_A = 25^\circ\text{C}$		7300		
Rise and fall time	$G = 2$, $V_O = 5\text{-V}_{PP}$, $R_F = 1.21\text{ k}\Omega$	$T_A = 25^\circ\text{C}$		5		ns
Settling time to 0.1%	$G = -2$, $V_O = 2\text{ V}_{PP}$ step	$T_A = 25^\circ\text{C}$		42		ns
Settling time to 0.01%	$G = -2$, $V_O = 2\text{ V}_{PP}$ step	$T_A = 25^\circ\text{C}$		72		
HARMONIC DISTORTION						
2nd Harmonic distortion	$G = 2$, $R_F = 1.21\text{ k}\Omega$, $V_O = 2\text{ V}_{PP}$, $f = 10\text{ MHz}$	$R_L = 100\ \Omega$, $T_A = 25^\circ\text{C}$		66		dBc
		$R_L = 1\text{ k}\Omega$, $T_A = 25^\circ\text{C}$		77		
		$R_L = 100\ \Omega$, $T_A = 25^\circ\text{C}$		74		
		$R_L = 1\text{ k}\Omega$, $T_A = 25^\circ\text{C}$		69		
Input voltage noise	$f > 10\text{ kHz}$	$T_A = 25^\circ\text{C}$		2		nV / $\sqrt{\text{Hz}}$
Noninverting input current noise	$f > 10\text{ kHz}$	$T_A = 25^\circ\text{C}$		14		pA / $\sqrt{\text{Hz}}$
Inverting input current noise	$f > 10\text{ kHz}$	$T_A = 25^\circ\text{C}$		17		pA / $\sqrt{\text{Hz}}$
Differential gain	$G = 2$, $R_L = 150\ \Omega$, $R_F = 1.21\text{ k}\Omega$	NTSC, $T_A = 25^\circ\text{C}$		0.013%		
		PAL, $T_A = 25^\circ\text{C}$		0.011%		
Differential phase		NTSC, $T_A = 25^\circ\text{C}$		0.020°		
		PAL, $T_A = 25^\circ\text{C}$		0.026°		
DC PERFORMANCE						
Transimpedance	$V_O = \pm 7.5\text{ V}$, Gain = 1	$T_A = 25^\circ\text{C}$		850		k Ω
		$T_A = 25^\circ\text{C}$		350		
		$T_A = 0^\circ\text{C to } 70^\circ\text{C}$		300		
		$T_A = -40^\circ\text{C to } 85^\circ\text{C}$		300		
Input offset voltage	$V_{CM} = 0\text{ V}$	$T_A = 25^\circ\text{C}$		0.9		mV
		$T_A = 25^\circ\text{C}$		3		
		$T_A = 0^\circ\text{C to } 70^\circ\text{C}$		4		
		$T_A = -40^\circ\text{C to } 85^\circ\text{C}$		4		
Average offset voltage drift	$V_{CM} = 0\text{ V}$	$T_A = 0^\circ\text{C to } 70^\circ\text{C}$		± 10		$\mu\text{V}/^\circ\text{C}$
		$T_A = -40^\circ\text{C to } 85^\circ\text{C}$		± 10		
Noninverting input bias current	$V_{CM} = 0\text{ V}$	$T_A = 25^\circ\text{C}$		4		μA
		$T_A = 25^\circ\text{C}$		15		
		$T_A = 0^\circ\text{C to } 70^\circ\text{C}$		20		
		$T_A = -40^\circ\text{C to } 85^\circ\text{C}$		20		
Average bias current drift	$V_{CM} = 0\text{ V}$	$T_A = 0^\circ\text{C to } 70^\circ\text{C}$		± 20		nA/ $^\circ\text{C}$
		$T_A = -40^\circ\text{C to } 85^\circ\text{C}$		± 20		
Inverting input bias current	$V_{CM} = 0\text{ V}$	$T_A = 25^\circ\text{C}$		3.5		μA
		$T_A = 25^\circ\text{C}$		15		
		$T_A = 0^\circ\text{C to } 70^\circ\text{C}$		20		
		$-40^\circ\text{C to } 85^\circ\text{C}$		20		
Average bias current drift	$V_{CM} = 0\text{ V}$	$T_A = 0^\circ\text{C to } 70^\circ\text{C}$		± 20		nA/ $^\circ\text{C}$
		$T_A = -40^\circ\text{C to } 85^\circ\text{C}$		± 20		

Electrical Characteristics THS3091 (continued)
 $V_S = \pm 15\text{ V}$, $R_F = 1.21\text{ k}\Omega$, $R_L = 100\ \Omega$, and $G = 2$ (unless otherwise noted)

PARAMETER	TEST CONDITIONS	MIN	TYP	MAX	UNIT
Input offset current	$V_{CM} = 0\text{ V}$	$T_A = 25^\circ\text{C}$	1.7		μA
		$T_A = 25^\circ\text{C}$		10	
		$T_A = 0^\circ\text{C to } 70^\circ\text{C}$		15	
		$T_A = -40^\circ\text{C to } 85^\circ\text{C}$		15	
Average offset current drift	$V_{CM} = 0\text{ V}$	$T_A = 0^\circ\text{C to } 70^\circ\text{C}$	± 20		$\text{nA}/^\circ\text{C}$
		$T_A = -40^\circ\text{C to } 85^\circ\text{C}$	± 20		
INPUT CHARACTERISTICS					
Common-mode input range		$T_A = 25^\circ\text{C}$	± 13.6		V
		$T_A = 25^\circ\text{C}$	± 13.3		
		$T_A = 0^\circ\text{C to } 70^\circ\text{C}$	± 13		
		$T_A = -40^\circ\text{C to } 85^\circ\text{C}$	± 13		
Common-mode rejection ratio	$V_{CM} = \pm 10\text{ V}$	$T_A = 25^\circ\text{C}$	69		dB
		$T_A = 25^\circ\text{C}$	62		
		$T_A = 0^\circ\text{C to } 70^\circ\text{C}$	59		
		$T_A = -40^\circ\text{C to } 85^\circ\text{C}$	59		
Noninverting input resistance		$T_A = 25^\circ\text{C}$	1.3		$\text{M}\Omega$
Noninverting input capacitance		$T_A = 25^\circ\text{C}$	0.1		pF
Inverting input resistance		$T_A = 25^\circ\text{C}$	30		Ω
Inverting input capacitance		$T_A = 25^\circ\text{C}$	1.4		pF

Electrical Characteristics THS3091 (continued)
 $V_S = \pm 15\text{ V}$, $R_F = 1.21\text{ k}\Omega$, $R_L = 100\ \Omega$, and $G = 2$ (unless otherwise noted)

PARAMETER	TEST CONDITIONS	MIN	TYP	MAX	UNIT
OUTPUT CHARACTERISTICS					
Output voltage swing	$R_L = 1\text{ k}\Omega$	$T_A = 25^\circ\text{C}$	± 13.2		V
		$T_A = 25^\circ\text{C}$	± 12.8		
		$T_A = 0^\circ\text{C to } 70^\circ\text{C}$	± 12.5		
		$T_A = -40^\circ\text{C to } 85^\circ\text{C}$	± 12.5		
	$R_L = 100\ \Omega$	$T_A = 25^\circ\text{C}$	± 12.5		
		$T_A = 25^\circ\text{C}$	± 12.1		
		$T_A = 0^\circ\text{C to } 70^\circ\text{C}$	± 11.8		
		$T_A = -40^\circ\text{C to } 85^\circ\text{C}$	± 11.8		
Output current (sourcing)	$R_L = 40\ \Omega$	$T_A = 25^\circ\text{C}$	280		mA
		$T_A = 25^\circ\text{C}$	225		
		$T_A = 0^\circ\text{C to } 70^\circ\text{C}$	200		
		$T_A = -40^\circ\text{C to } 85^\circ\text{C}$	200		
Output current (sinking)	$R_L = 40\ \Omega$	$T_A = 25^\circ\text{C}$	250		mA
		$T_A = 25^\circ\text{C}$	200		
		$T_A = 0^\circ\text{C to } 70^\circ\text{C}$	175		
		$T_A = -40^\circ\text{C to } 85^\circ\text{C}$	175		
Output impedance	$f = 1\text{ MHz}$, Closed loop	$T_A = 25^\circ\text{C}$	0.06		Ω
POWER SUPPLY					
Specified operating voltage		$T_A = 25^\circ\text{C}$	± 15		V
		$T_A = 25^\circ\text{C}$	± 16		
		$T_A = 0^\circ\text{C to } 70^\circ\text{C}$	± 16		
		$T_A = -40^\circ\text{C to } 85^\circ\text{C}$	± 16		
Maximum quiescent current		$T_A = 25^\circ\text{C}$	9.5		mA
		$T_A = 25^\circ\text{C}$	10.5		
		$T_A = 0^\circ\text{C to } 70^\circ\text{C}$	11		
		$T_A = -40^\circ\text{C to } 85^\circ\text{C}$	11		
Minimum quiescent current		$T_A = 25^\circ\text{C}$	9.5		mA
		$T_A = 25^\circ\text{C}$	8.5		
		$T_A = 0^\circ\text{C to } 70^\circ\text{C}$	8		
		$T_A = -40^\circ\text{C to } 85^\circ\text{C}$	8		
Power supply rejection (+PSRR)	$V_{S+} = 15.5\text{ V to } 14.5\text{ V}$, $V_{S-} = 15\text{ V}$	$T_A = 25^\circ\text{C}$	75		dB
		$T_A = 25^\circ\text{C}$	70		
		$T_A = 0^\circ\text{C to } 70^\circ\text{C}$	65		
		$T_A = -40^\circ\text{C to } 85^\circ\text{C}$	65		
Power supply rejection (-PSRR)	$V_{S+} = 15\text{ V}$, $V_{S-} = -15.5\text{ V to } -14.5\text{ V}$	$T_A = 25^\circ\text{C}$	73		dB
		$T_A = 25^\circ\text{C}$	68		
		$T_A = 0^\circ\text{C to } 70^\circ\text{C}$	65		
		$T_A = -40^\circ\text{C to } 85^\circ\text{C}$	65		
POWER-DOWN CHARACTERISTICS (THS3091 ONLY)					
REF voltage range ⁽¹⁾		$T_A = 25^\circ\text{C}$	$V_{S+} - 4$		V
		$T_A = 25^\circ\text{C}$	V_{S-}		
Power-down voltage level ⁽¹⁾	Enable	$T_A = 25^\circ\text{C}$	$\overline{\text{PD}} \geq \text{REF} + 2$		V
	Disable	$T_A = 25^\circ\text{C}$	$\overline{\text{PD}} \leq \text{REF} + 8$		

(1) For detailed information on the behavior of the power-down circuit, see the *power-down functionality* and *power-down reference* sections in the Application Information section of this data sheet.

Electrical Characteristics THS3091 (continued)
 $V_S = \pm 15\text{ V}$, $R_F = 1.21\text{ k}\Omega$, $R_L = 100\ \Omega$, and $G = 2$ (unless otherwise noted)

PARAMETER	TEST CONDITIONS	MIN	TYP	MAX	UNIT
Power-down quiescent current	$\overline{PD} = 0\text{ V}$	$T_A = 25^\circ\text{C}$	500		μA
		$T_A = 25^\circ\text{C}$		700	
		$T_A = 0^\circ\text{C to } 70^\circ\text{C}$		800	
		$T_A = -40^\circ\text{C to } 85^\circ\text{C}$		800	
V_{PD} quiescent current	$V_{PD} = 0\text{ V}$, $\text{REF} = 0\text{ V}$,	$T_A = 25^\circ\text{C}$	11		μA
		$T_A = 25^\circ\text{C}$		15	
		$T_A = 0^\circ\text{C to } 70^\circ\text{C}$		20	
		$T_A = -40^\circ\text{C to } 85^\circ\text{C}$		20	
	$V_{PD} = 3.3\text{ V}$, $\text{REF} = 0\text{ V}$	$T_A = 25^\circ\text{C}$	11		
		$T_A = 25^\circ\text{C}$		15	
		$T_A = 0^\circ\text{C to } 70^\circ\text{C}$		20	
		$T_A = -40^\circ\text{C to } 85^\circ\text{C}$		20	
Turnon time delay	90% of final value	$T_A = 25^\circ\text{C}$	60		μs
Turnoff time delay	10% of final value	$T_A = 25^\circ\text{C}$	150		

6.6 Electrical Characteristics THS3095
 $V_S = \pm 5\text{ V}$, $R_F = 1.15\text{ k}\Omega$, $R_L = 100\ \Omega$, and $G = 2$ (unless otherwise noted)

PARAMETER	TEST CONDITIONS	MIN	TYP	MAX	UNIT
AC PERFORMANCE					
Small-signal bandwidth, -3 dB	$G = 1$, $R_F = 1.78\text{ k}\Omega$, $V_O = 200\text{ mV}_{PP}$	$T_A = 25^\circ\text{C}$	190		MHz
	$G = 2$, $R_F = 1.15\text{ k}\Omega$, $V_O = 200\text{ mV}_{PP}$	$T_A = 25^\circ\text{C}$	180		
	$G = 5$, $R_F = 1\text{ k}\Omega$, $V_O = 200\text{ mV}_{PP}$	$T_A = 25^\circ\text{C}$	160		
	$G = 10$, $R_F = 866\ \Omega$, $V_O = 200\text{ mV}_{PP}$	$T_A = 25^\circ\text{C}$	150		
0.1-dB Bandwidth flatness	$G = 2$, $R_F = 1.15\text{ k}\Omega$, $V_O = 200\text{ mV}_{PP}$	$T_A = 25^\circ\text{C}$	65		
Large-signal bandwidth	$G = 2$, $R_F = 1.15\text{ k}\Omega$, $V_O = 4\text{ V}_{PP}$	$T_A = 25^\circ\text{C}$	160		
Slew rate (25% to 75% level)	$G = 2$, $V_O = 5\text{-V step}$, $R_F = 1.21\text{ k}\Omega$	$T_A = 25^\circ\text{C}$	1400		$\text{V}/\mu\text{s}$
	$G = 5$, $V_O = 5\text{-V step}$, $R_F = 1\text{ k}\Omega$	$T_A = 25^\circ\text{C}$	1900		
Rise and fall time	$G = 2$, $V_O = 5\text{-V step}$, $R_F = 1.21\text{ k}\Omega$	$T_A = 25^\circ\text{C}$	5		ns
Settling time to 0.1%	$G = -2$, $V_O = 2\text{ V}_{PP}$ step	$T_A = 25^\circ\text{C}$	35		ns
Settling time to 0.01%	$G = -2$, $V_O = 2\text{ V}_{PP}$ step	$T_A = 25^\circ\text{C}$	73		
HARMONIC DISTORTION					
2nd Harmonic distortion	$G = 2$, $R_F = 1.15\text{ k}\Omega$, $V_O = 2\text{ V}_{PP}$, $f = 10\text{ MHz}$	$R_L = 100\ \Omega$	$T_A = 25^\circ\text{C}$	77	dBc
		$R_L = 1\text{ k}\Omega$	$T_A = 25^\circ\text{C}$	73	
$R_L = 100\ \Omega$		$T_A = 25^\circ\text{C}$	70		
$R_L = 1\text{ k}\Omega$		$T_A = 25^\circ\text{C}$	68		
Input voltage noise	$f > 10\text{ kHz}$	$T_A = 25^\circ\text{C}$	2		$\text{nV} / \sqrt{\text{Hz}}$
Noninverting input current noise	$f > 10\text{ kHz}$	$T_A = 25^\circ\text{C}$	14		$\text{pA} / \sqrt{\text{Hz}}$
Inverting input current noise	$f > 10\text{ kHz}$	$T_A = 25^\circ\text{C}$	17		$\text{pA} / \sqrt{\text{Hz}}$
Differential gain	$G = 2$, $R_L = 150\ \Omega$, $R_F = 1.15\text{ k}\Omega$	NTSC	$T_A = 25^\circ\text{C}$	0.027%	
		PAL	$T_A = 25^\circ\text{C}$	0.025%	
NTSC		$T_A = 25^\circ\text{C}$	0.04°		
PAL		$T_A = 25^\circ\text{C}$	0.05°		
Differential phase					
DC PERFORMANCE					
Transimpedance	$V_O = \pm 2.5\text{ V}$, $\text{Gain} = 1$	$T_A = 25^\circ\text{C}$	700		$\text{k}\Omega$
		$T_A = 25^\circ\text{C}$	250		
		$T_A = 0^\circ\text{C to } 70^\circ\text{C}$	200		
		$T_A = -40^\circ\text{C to } 85^\circ\text{C}$	200		

Electrical Characteristics THS3095 (continued)
 $V_S = \pm 5\text{ V}$, $R_F = 1.15\text{ k}\Omega$, $R_L = 100\ \Omega$, and $G = 2$ (unless otherwise noted)

PARAMETER	TEST CONDITIONS	MIN	TYP	MAX	UNIT
Input offset voltage	$V_{CM} = 0\text{ V}$	$T_A = 25^\circ\text{C}$		0.3	mV
		$T_A = 25^\circ\text{C}$		2	
		$T_A = 0^\circ\text{C to } 70^\circ\text{C}$		3	
		$T_A = -40^\circ\text{C to } 85^\circ\text{C}$		3	
Average offset voltage drift	$V_{CM} = 0\text{ V}$	$T_A = 0^\circ\text{C to } 70^\circ\text{C}$		± 10	$\mu\text{V}/^\circ\text{C}$
		$T_A = -40^\circ\text{C to } 85^\circ\text{C}$		± 10	
Noninverting input bias current	$V_{CM} = 0\text{ V}$	$T_A = 25^\circ\text{C}$		2	μA
		$T_A = 25^\circ\text{C}$		15	
		$T_A = 0^\circ\text{C to } 70^\circ\text{C}$		20	
		$T_A = -40^\circ\text{C to } 85^\circ\text{C}$		20	
Average bias current drift	$V_{CM} = 0\text{ V}$	$T_A = 0^\circ\text{C to } 70^\circ\text{C}$		± 20	$\text{nA}/^\circ\text{C}$
		$T_A = -40^\circ\text{C to } 85^\circ\text{C}$		± 20	
Inverting input bias current	$V_{CM} = 0\text{ V}$	$T_A = 25^\circ\text{C}$		5	μA
		$T_A = 25^\circ\text{C}$		15	
		$T_A = 0^\circ\text{C to } 70^\circ\text{C}$		20	
		$T_A = -40^\circ\text{C to } 85^\circ\text{C}$		20	
Average bias current drift	$V_{CM} = 0\text{ V}$	$T_A = 0^\circ\text{C to } 70^\circ\text{C}$		± 20	$\text{nA}/^\circ\text{C}$
		$T_A = -40^\circ\text{C to } 85^\circ\text{C}$		± 20	
Input offset current	$V_{CM} = 0\text{ V}$	$T_A = 25^\circ\text{C}$		1	μA
		$T_A = 25^\circ\text{C}$		10	
		$T_A = 0^\circ\text{C to } 70^\circ\text{C}$		15	
		$T_A = -40^\circ\text{C to } 85^\circ\text{C}$		15	
Average offset current drift	$V_{CM} = 0\text{ V}$	$T_A = 0^\circ\text{C to } 70^\circ\text{C}$		± 20	$\text{nA}/^\circ\text{C}$
		$T_A = -40^\circ\text{C to } 85^\circ\text{C}$		± 20	
INPUT CHARACTERISTICS					
Common-mode input range		$T_A = 25^\circ\text{C}$		± 3.6	V
		$T_A = 25^\circ\text{C}$		± 3.3	
		$T_A = 0^\circ\text{C to } 70^\circ\text{C}$		± 3	
		$T_A = -40^\circ\text{C to } 85^\circ\text{C}$		± 3	
Common-mode rejection ratio	$V_{CM} = \pm 2.0\text{ V}$, $V_O = 0\text{ V}$	$T_A = 25^\circ\text{C}$		66	dB
		$T_A = 25^\circ\text{C}$		60	
		$T_A = 0^\circ\text{C to } 70^\circ\text{C}$		57	
		$T_A = -40^\circ\text{C to } 85^\circ\text{C}$		57	
Noninverting input resistance	$T_A = 25^\circ\text{C}$		1.1		M Ω
Noninverting input capacitance	$T_A = 25^\circ\text{C}$		1.2		pF
Inverting input resistance	$T_A = 25^\circ\text{C}$		32		Ω
Inverting input capacitance	$T_A = 25^\circ\text{C}$		1.5		pF

Electrical Characteristics THS3095 (continued)
 $V_S = \pm 5\text{ V}$, $R_F = 1.15\text{ k}\Omega$, $R_L = 100\ \Omega$, and $G = 2$ (unless otherwise noted)

PARAMETER	TEST CONDITIONS	MIN	TYP	MAX	UNIT
OUTPUT CHARACTERISTICS					
Output voltage swing	$R_L = 1\text{ k}\Omega$	$T_A = 25^\circ\text{C}$	± 3.4		V
		$T_A = 25^\circ\text{C}$	± 3.1		
		$T_A = 0^\circ\text{C to } 70^\circ\text{C}$	± 2.8		
		$T_A = -40^\circ\text{C to } 85^\circ\text{C}$	± 2.8		
	$R_L = 100\ \Omega$	$T_A = 25^\circ\text{C}$	± 3.1		
		$T_A = 25^\circ\text{C}$	± 2.7		
		$T_A = 0^\circ\text{C to } 70^\circ\text{C}$	± 2.5		
		$T_A = -40^\circ\text{C to } 85^\circ\text{C}$	± 2.5		
Output current (sourcing)	$R_L = 10\ \Omega$	$T_A = 25^\circ\text{C}$	180		mA
		$T_A = 25^\circ\text{C}$	140		
		$T_A = 0^\circ\text{C to } 70^\circ\text{C}$	120		
		$T_A = -40^\circ\text{C to } 85^\circ\text{C}$	120		
Output current (sinking)	$R_L = 10\ \Omega$	$T_A = 25^\circ\text{C}$	-160		mA
		$T_A = 25^\circ\text{C}$	-140		
		$T_A = 0^\circ\text{C to } 70^\circ\text{C}$	-120		
		$T_A = -40^\circ\text{C to } 85^\circ\text{C}$	-120		
Output impedance	$f = 1\text{ MHz}$, Closed loop	$T_A = 25^\circ\text{C}$	0.09		Ω
POWER SUPPLY					
Specified operating voltage	$T_A = 25^\circ\text{C}$		± 5		V
	$T_A = 25^\circ\text{C}$		± 4.5		
	$T_A = 0^\circ\text{C to } 70^\circ\text{C}$		± 4.5		
	$T_A = -40^\circ\text{C to } 85^\circ\text{C}$		± 4.5		
Maximum quiescent current	$T_A = 25^\circ\text{C}$		8.2		mA
	$T_A = 25^\circ\text{C}$		9		
	$T_A = 0^\circ\text{C to } 70^\circ\text{C}$		9.5		
	$T_A = -40^\circ\text{C to } 85^\circ\text{C}$		9.5		
Minimum quiescent current	$T_A = 25^\circ\text{C}$		8.2		mA
	$T_A = 25^\circ\text{C}$		7		
	$T_A = 0^\circ\text{C to } 70^\circ\text{C}$		6.5		
	$T_A = -40^\circ\text{C to } 85^\circ\text{C}$		6.5		
Power supply rejection (+PSRR)	$V_{S+} = 5.5\text{ V to } 4.5\text{ V}$, $V_{S-} = 5\text{ V}$	$T_A = 25^\circ\text{C}$	73		dB
		$T_A = 25^\circ\text{C}$	68		
		$T_A = 0^\circ\text{C to } 70^\circ\text{C}$	63		
		$T_A = -40^\circ\text{C to } 85^\circ\text{C}$	63		
Power supply rejection (-PSRR)	$V_{S+} = 5\text{ V}$, $V_{S-} = -4.5\text{ V to } -5.5\text{ V}$	$T_A = 25^\circ\text{C}$	71		dB
		$T_A = 25^\circ\text{C}$	65		
		$T_A = 0^\circ\text{C to } 70^\circ\text{C}$	60		
		$T_A = -40^\circ\text{C to } 85^\circ\text{C}$	60		

Electrical Characteristics THS3095 (continued)

 $V_S = \pm 5\text{ V}$, $R_F = 1.15\text{ k}\Omega$, $R_L = 100\ \Omega$, and $G = 2$ (unless otherwise noted)

PARAMETER	TEST CONDITIONS		MIN	TYP	MAX	UNIT
POWER-DOWN CHARACTERISTICS (THS3095 ONLY)						
REF voltage range ⁽¹⁾	$T_A = 25^\circ\text{C}$		$V_{S+} - 4$			V
	$T_A = 25^\circ\text{C}$		V_{S-}			
Power-down voltage level ⁽¹⁾	Enable	$T_A = 25^\circ\text{C}$	$\overline{\text{PD}} \geq \text{REF} 2$			V
	Disable	$T_A = 25^\circ\text{C}$	$\overline{\text{PD}} \leq \text{REF} 0.8$			
Power-down quiescent current	$\overline{\text{PD}} = 0\text{V}$	$T_A = 25^\circ\text{C}$	300			μA
		$T_A = 25^\circ\text{C}$	500			
		$T_A = 0^\circ\text{C}$ to 70°C	600			
		$T_A = -40^\circ\text{C}$ to 85°C	600			
V_{PD} quiescent current	$V_{\text{PD}} = 0\text{ V}, \text{ REF} = 0\text{ V},$	$T_A = 25^\circ\text{C}$	11			μA
		$T_A = 25^\circ\text{C}$	15			
		$T_A = 0^\circ\text{C}$ to 70°C	20			
		$T_A = -40^\circ\text{C}$ to 85°C	20			
	$V_{\text{PD}} = 3.3\text{ V}, \text{ REF} = 0\text{ V}$	$T_A = 25^\circ\text{C}$	11			
		$T_A = 25^\circ\text{C}$	15			
		$T_A = 0^\circ\text{C}$ to 70°C	20			
		$T_A = -40^\circ\text{C}$ to 85°C	20			
Turnon time delay	90% of final value	$T_A = 25^\circ\text{C}$	60			μs
Turnoff time delay	10% of final value	$T_A = 25^\circ\text{C}$	150			

(1) For detailed information on the behavior of the power-down circuit, see the *power-down functionality* and *power-down reference* sections in the Application Information section of this data sheet.

6.7 Dissipation Ratings Table

PACKAGE	θ_{JC} ($^\circ\text{C}/\text{W}$)	θ_{JA} ($^\circ\text{C}/\text{W}$) ⁽¹⁾	POWER RATING ⁽²⁾ $T_J = 125^\circ\text{C}$	
			$T_A = 25^\circ\text{C}$	$T_A = 85^\circ\text{C}$
D-8	38.3	97.5	1.02 W	410 mW
DDA-8	9.2	45.8	2.18 W	873 mW

- (1) This data was taken using the JEDEC standard High-K test PCB.
 (2) Power rating is determined with a junction temperature of 125°C . This is the point where distortion starts to substantially increase. Thermal management of the final PCB should strive to keep the junction temperature at or below 125°C for best performance and long-term reliability.

6.8 Typical Characteristics

Table 1. Table Of Graphs

±15-V GRAPHS	FIGURE
Noninverting small-signal frequency response	Figure 1, Figure 2
Inverting small-signal frequency response	Figure 3
0.1-dB gain flatness frequency response	Figure 4
Noninverting large-signal frequency response	Figure 5
Inverting large-signal frequency response	Figure 6
Capacitive load frequency response	Figure 7
Recommended R_{ISO} vs Capacitive load	Figure 8
2nd Harmonic distortion vs Frequency	Figure 9, Figure 11
3rd Harmonic distortion vs Frequency	Figure 10, Figure 12
2nd Harmonic distortion vs Frequency	Figure 13
3rd Harmonic distortion vs Frequency	Figure 14
Harmonic distortion vs Output voltage swing	Figure 15, Figure 16
Slew rate vs Output voltage step	Figure 17, Figure 18, Figure 19
Noise vs Frequency	Figure 20
Settling time	Figure 21, Figure 22
Quiescent current vs Supply voltage	Figure 23
Quiescent current vs Frequency	Figure 24
Output voltage vs Load resistance	Figure 25
Input bias and offset current vs Case temperature	Figure 26
Input offset voltage vs Case temperature	Figure 27
Transimpedance vs Frequency	Figure 28
Rejection ratio vs Frequency	Figure 29
Noninverting small-signal transient response	Figure 30
Inverting large-signal transient response	Figure 31, Figure 32
Overdrive recovery time	Figure 33
Differential gain vs Number of loads	Figure 34
Differential phase vs Number of loads	Figure 35
Closed-Loop output impedance vs Frequency	Figure 36
Power-down quiescent current vs Supply voltage	Figure 37
Turnon and turnoff time delay	Figure 38

Table 2. Table Of Graphs (Continued)

±5-V GRAPHS		FIGURE
Noninverting small-signal frequency response		Figure 39
Inverting small-signal frequency response		Figure 40
0.1-dB gain flatness frequency response		Figure 41
Noninverting large-signal frequency response		Figure 42
Inverting large-signal frequency response		Figure 43
Settling time		Figure 44
2nd Harmonic distortion	vs Frequency	Figure 45, Figure 47
3rd Harmonic distortion	vs Frequency	Figure 46, Figure 48
Harmonic distortion	vs Output voltage swing	Figure 49, Figure 50
Slew rate	vs Output voltage step	Figure 51, Figure 52, Figure 53
Quiescent current	vs Frequency	Figure 54
Output voltage	vs Load resistance	Figure 55
Input bias and offset current	vs Case temperature	Figure 56
Overdrive recovery time		Figure 57
Rejection ratio	vs Frequency	Figure 58

6.9 Typical Characteristics (± 15 V)

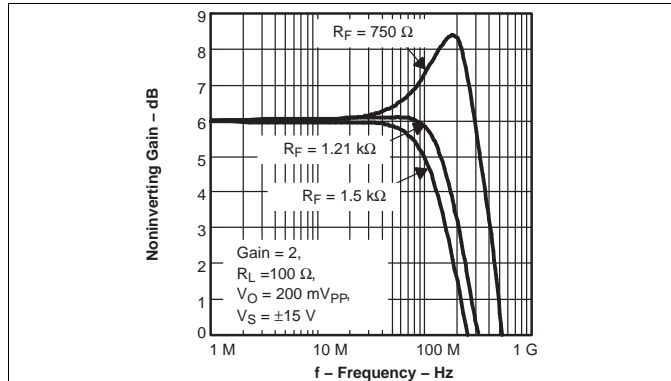

Figure 1. Noninverting Small-Signal Frequency Response

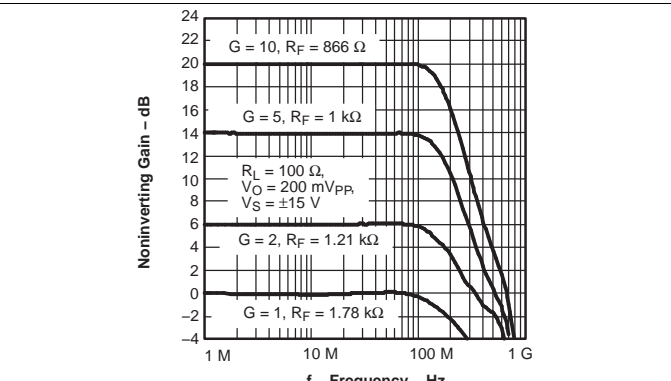

Figure 2. Noninverting Small-Signal Frequency Response

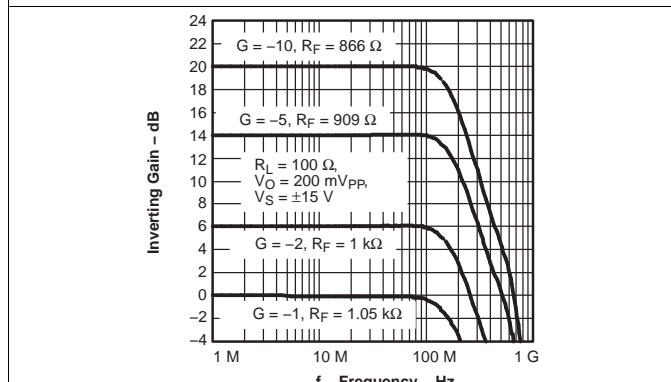

Figure 3. Inverting Small-Signal Frequency Response

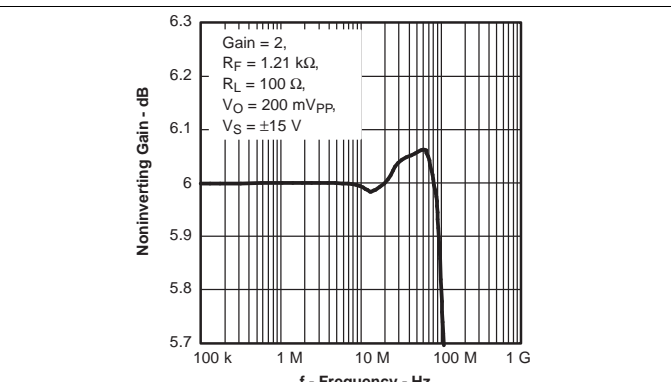

Figure 4. 0.1-dB Gain Flatness Frequency Response

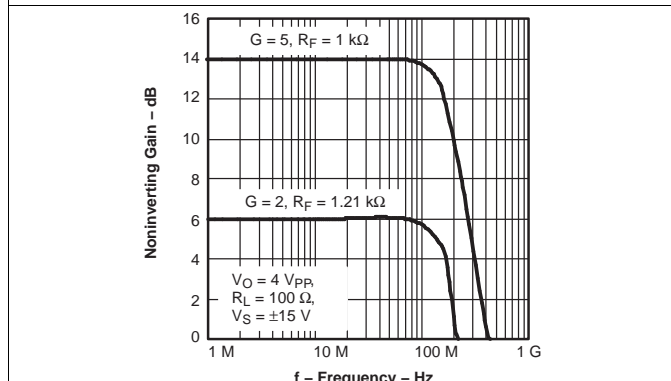

Figure 5. Noninverting Large-Signal Frequency Response

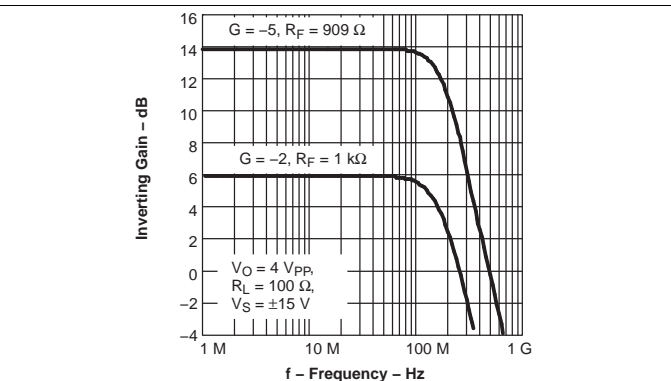

Figure 6. Inverting Large-Signal Frequency Response

Typical Characteristics ($\pm 15\text{ V}$) (continued)

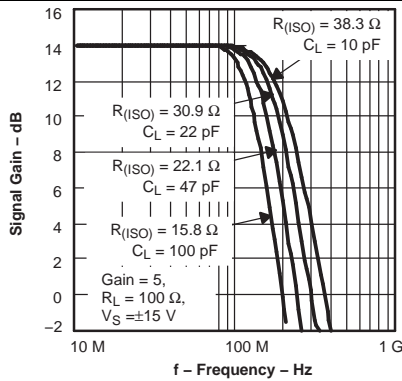

Figure 7. Capacitive Load Frequency Response

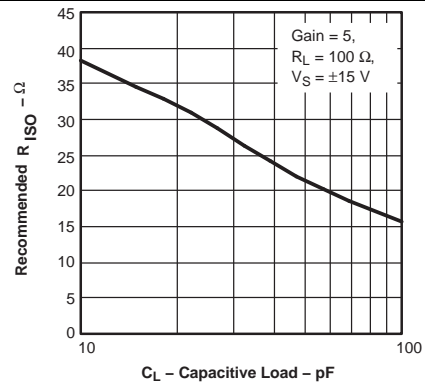

Figure 8. Recommended R_{ISO} vs Capacitive Load

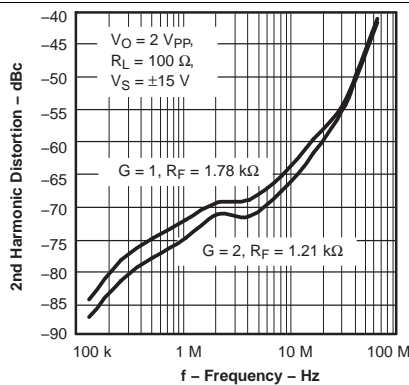

Figure 9. 2nd Harmonic Distortion vs Frequency

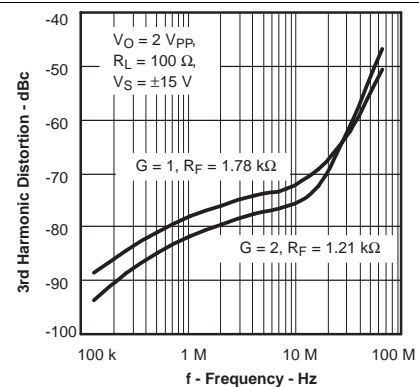

Figure 10. 3rd Harmonic Distortion vs Frequency

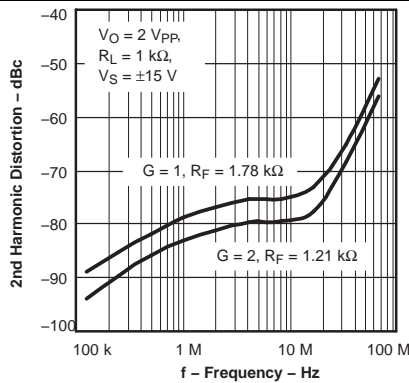

Figure 11. 2nd Harmonic Distortion vs Frequency

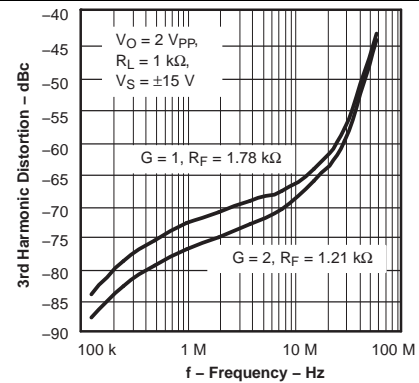

Figure 12. 3rd Harmonic Distortion vs Frequency

Typical Characteristics ($\pm 15\text{ V}$) (continued)

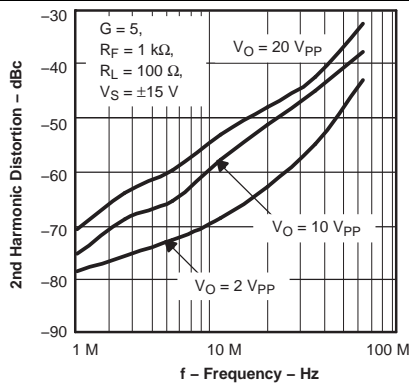

Figure 13. 2nd Harmonic Distortion vs Frequency

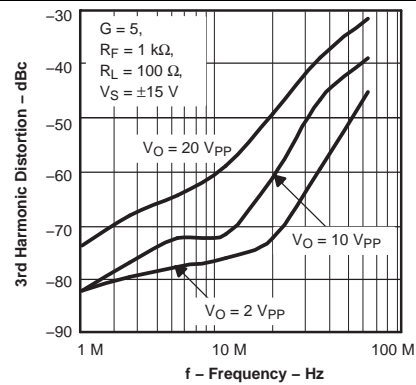

Figure 14. 3rd Harmonic Distortion vs Frequency

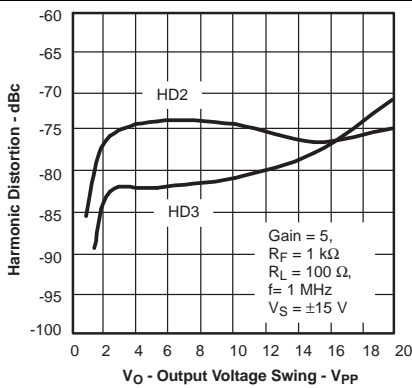

Figure 15. Harmonic Distortion vs Output Voltage Swing

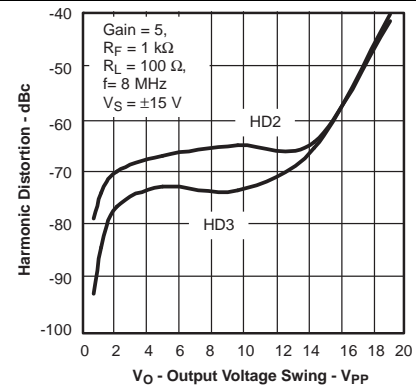

Figure 16. Harmonic Distortion vs Output Voltage Swing

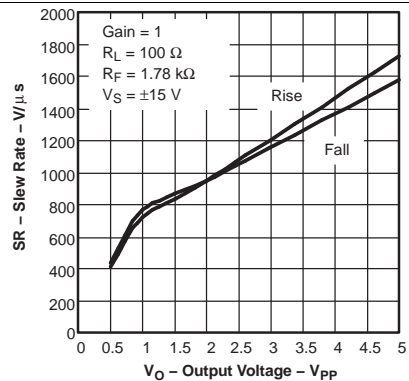

Figure 17. Slew Rate vs Output Voltage Step

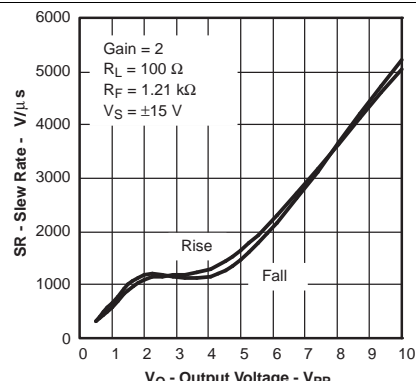

Figure 18. Slew Rate vs Output Voltage Step

Typical Characteristics ($\pm 15\text{ V}$) (continued)

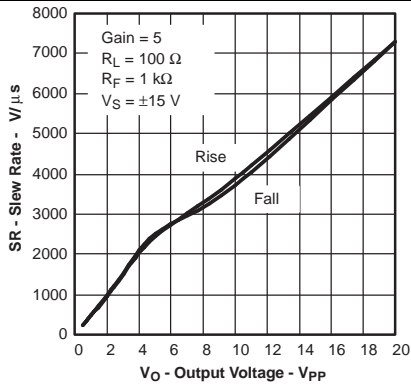

Figure 19. Slew Rate vs Output Voltage Step

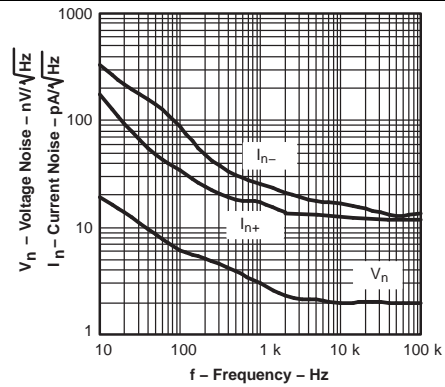

Figure 20. Noise vs Frequency

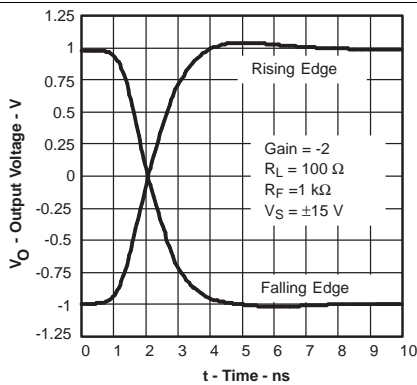

Figure 21. Settling Time

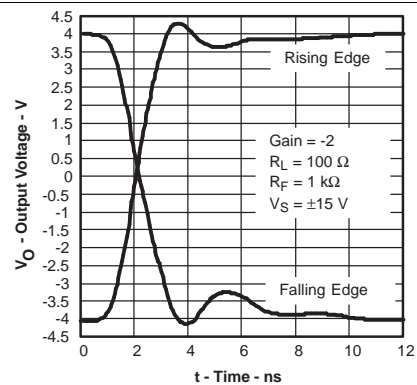

Figure 22. Settling Time

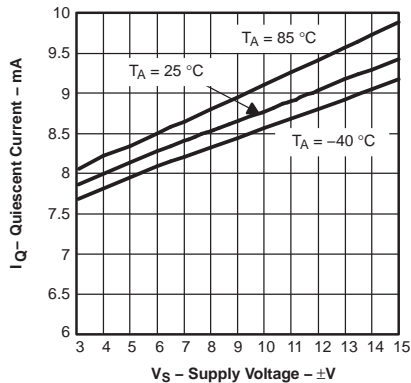

Figure 23. Quiescent Current vs Supply Voltage

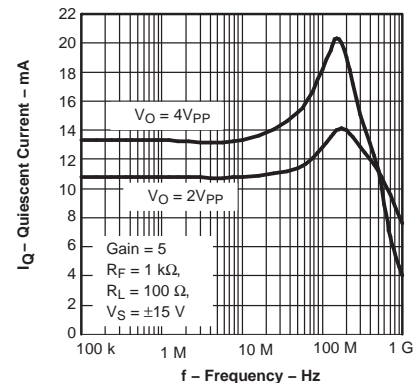

Figure 24. Quiescent Current vs Frequency

Typical Characteristics ($\pm 15\text{ V}$) (continued)

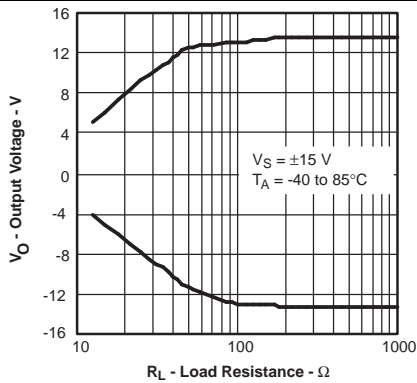

Figure 25. Output Voltage vs Load Resistance

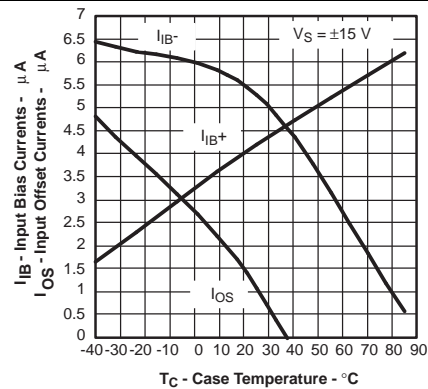

Figure 26. Input Bias and Offset Current vs Case Temperature

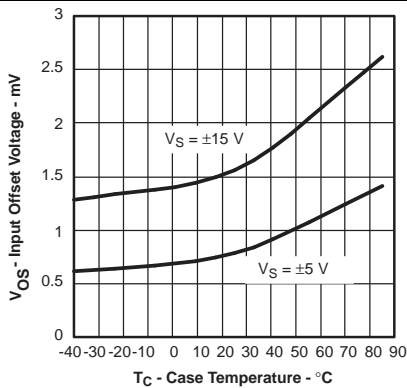

Figure 27. Input Offset Voltage vs Case Temperature

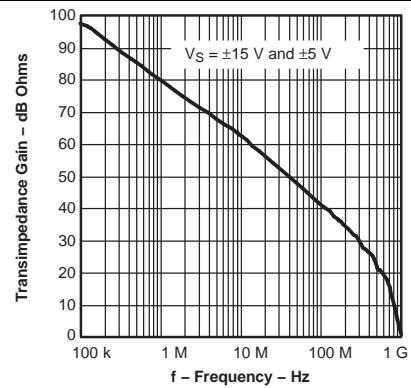

Figure 28. Transimpedance vs Frequency

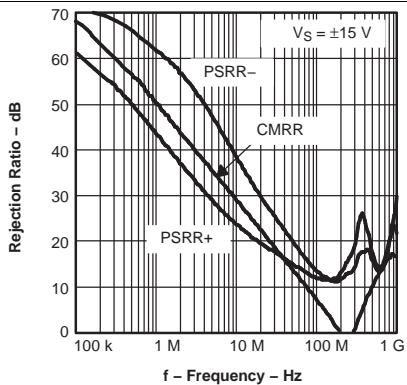

Figure 29. Rejection Ratio vs Frequency

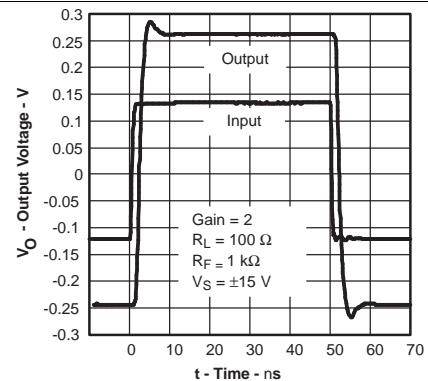
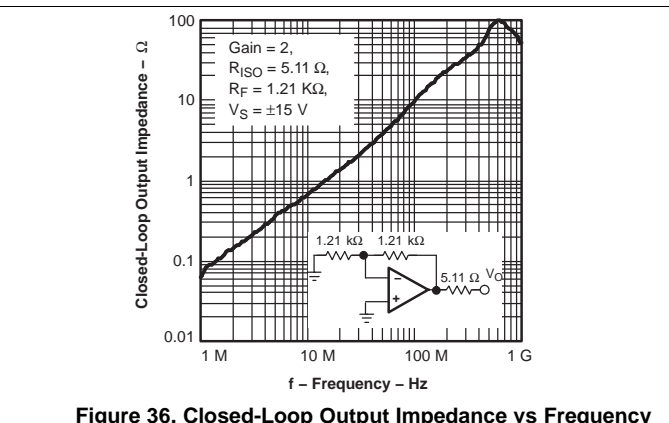
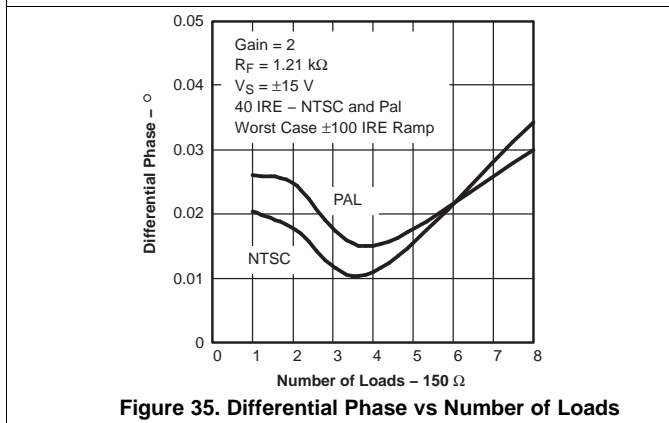
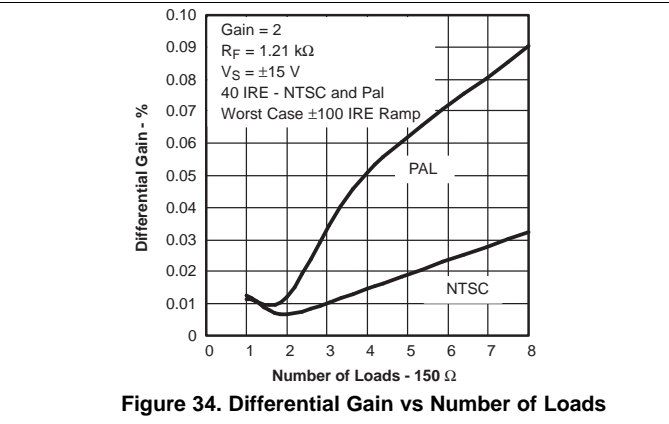
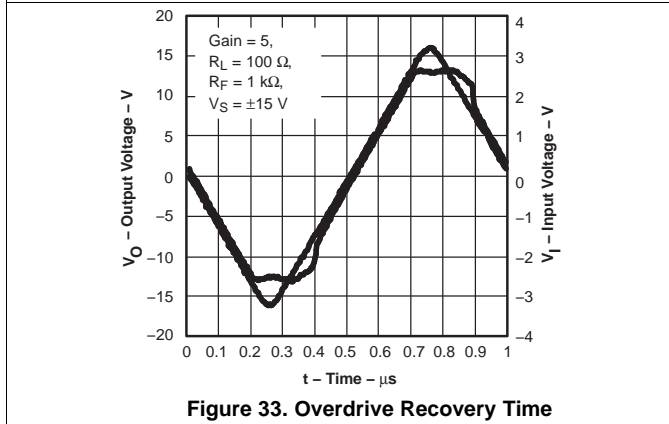
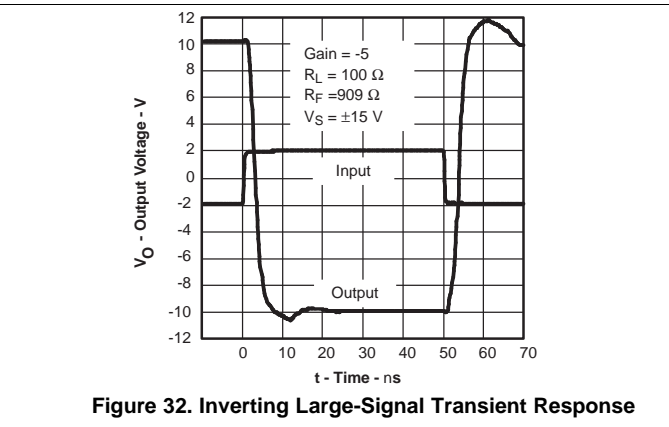
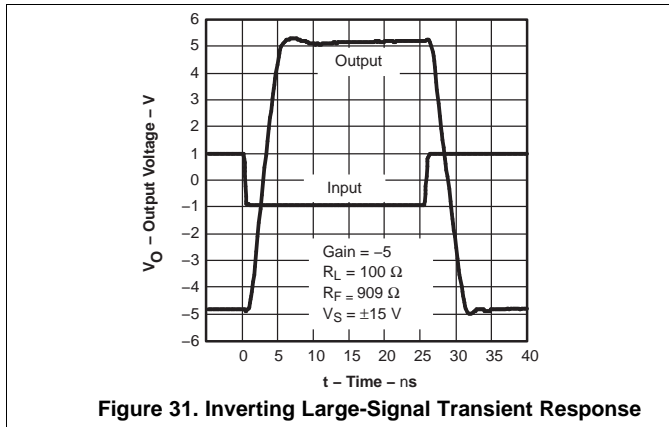

Figure 30. Noninverting Small-Signal Transient Response

Typical Characteristics ($\pm 15\text{ V}$) (continued)



Typical Characteristics (± 15 V) (continued)

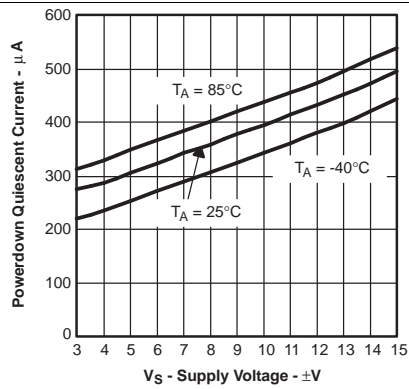

Figure 37. Power-Down Quiescent Current vs Supply Voltage

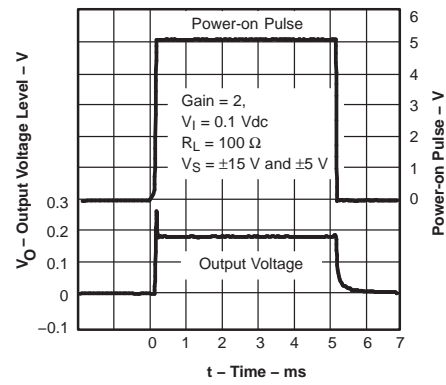

Figure 38. Turnon and Turnoff Time Delay

6.10 Typical Characteristics (± 5 V)

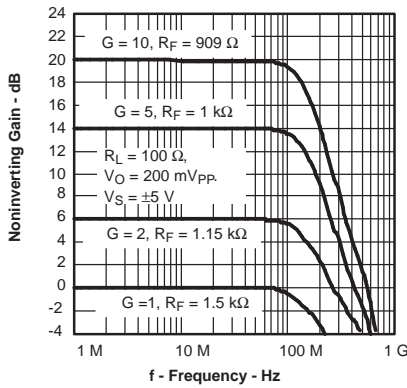

Figure 39. Noninverting Small-Signal Frequency Response

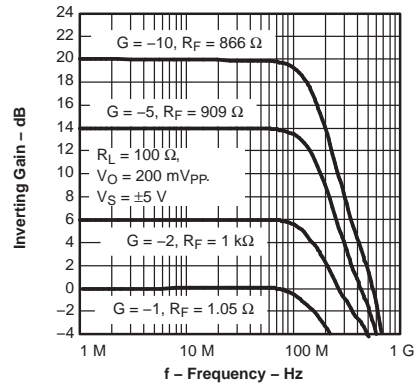

Figure 40. Inverting Small-Signal Frequency Response

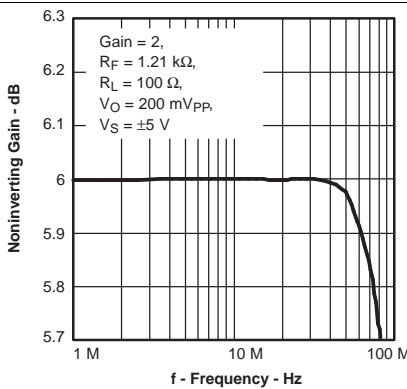

Figure 41. 0.1-dB Gain Flatness Frequency Response

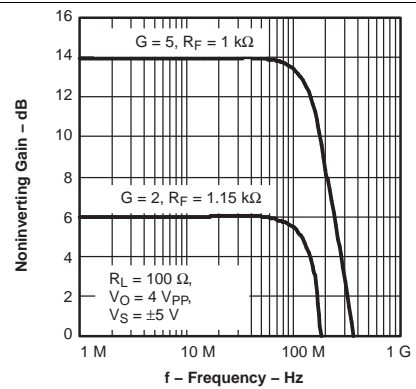

Figure 42. Noninverting Large-Signal Frequency Response

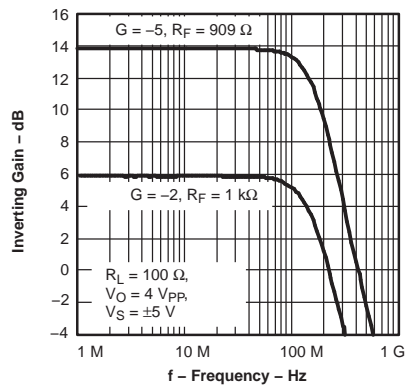

Figure 43. Inverting Large-Signal Frequency Response

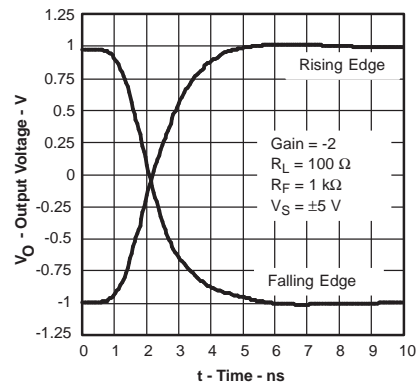
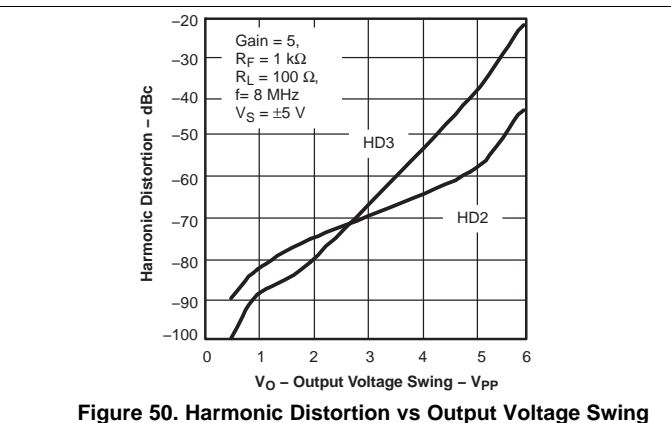
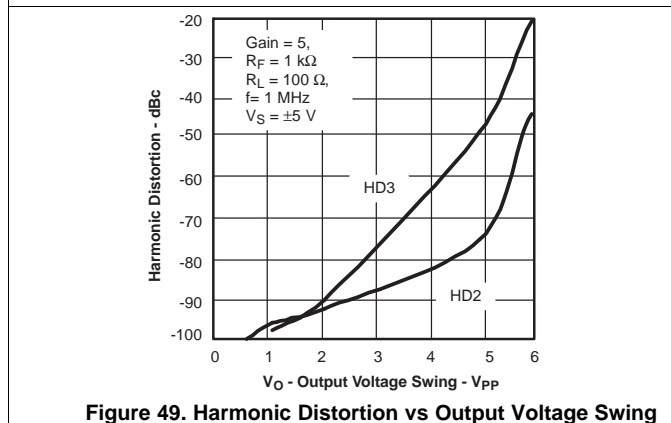
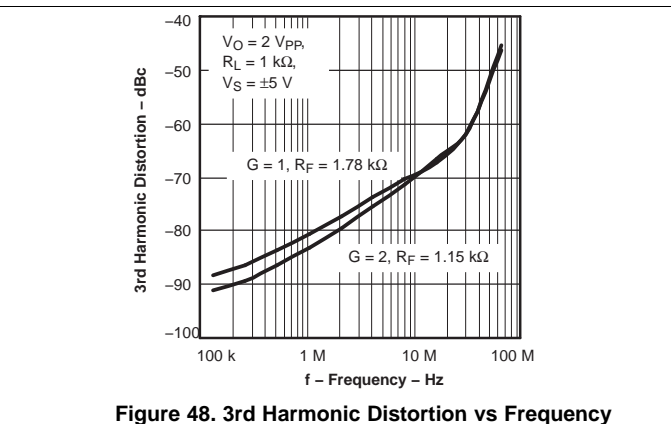
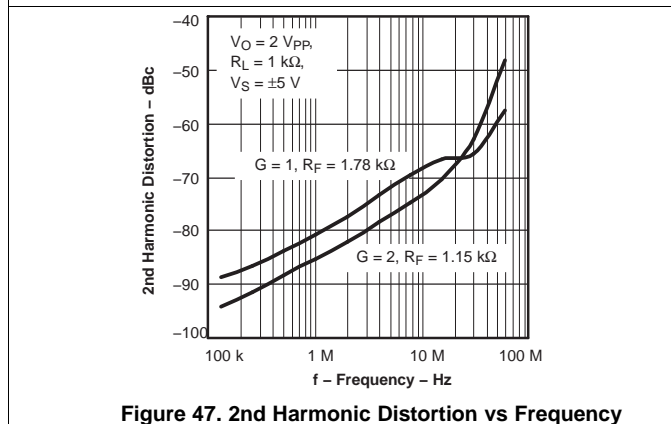
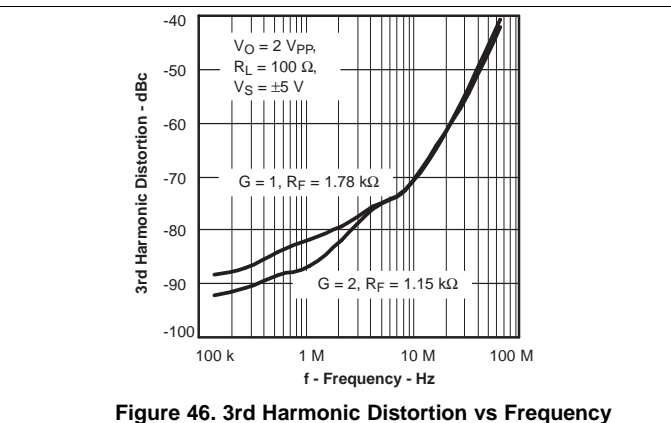
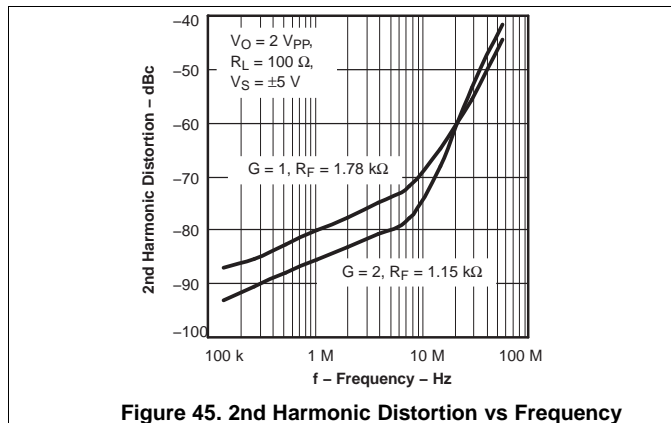

Figure 44. Settling Time

Typical Characteristics (± 5 V) (continued)



Typical Characteristics (± 5 V) (continued)

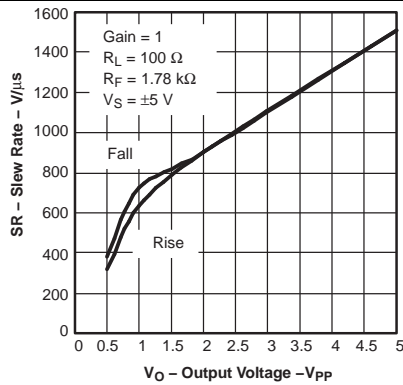

Figure 51. Slew Rate vs Output Voltage Step

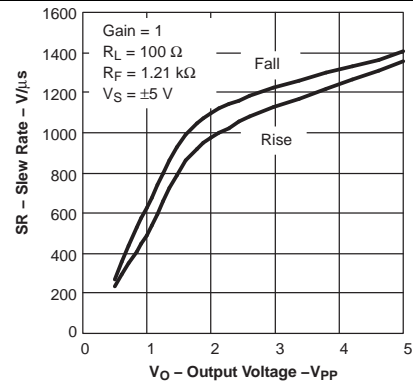

Figure 52. Slew Rate vs Output Voltage Step

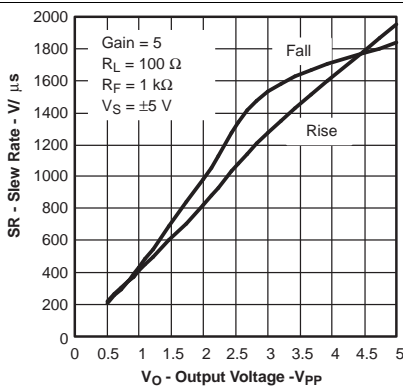

Figure 53. Slew Rate vs Output Voltage Step

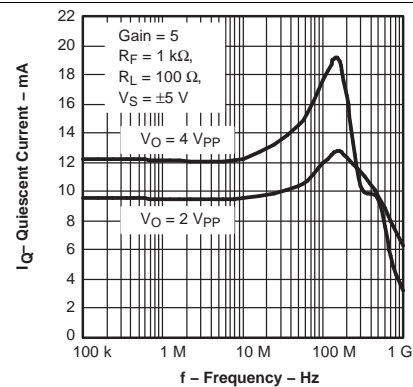

Figure 54. Quiescent Current vs Frequency

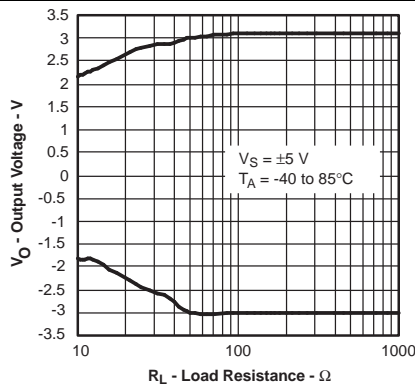

Figure 55. Output Voltage vs Load Resistance

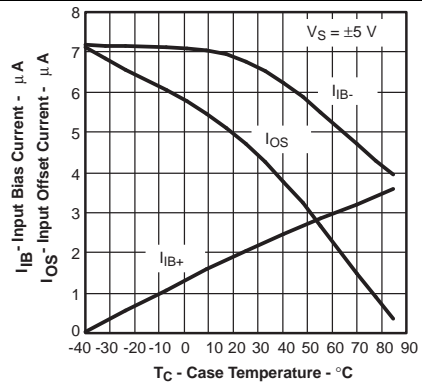
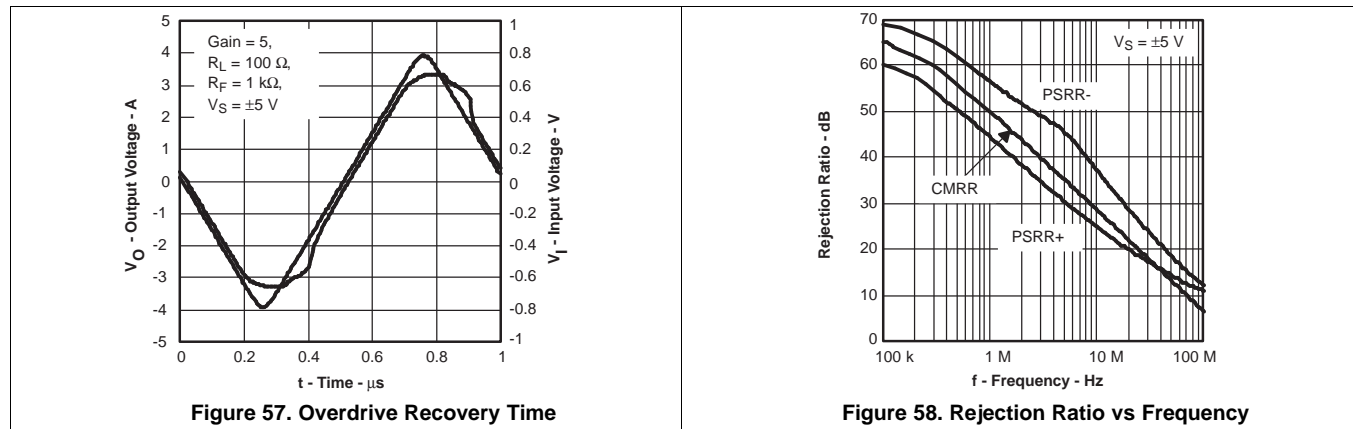

Figure 56. Input Bias and Offset Current vs Case Temperature

Typical Characteristics (± 5 V) (continued)



7 Detailed Description

7.1 Overview

The THS3091 and THS3095 are high-voltage, low-distortion, high-speed, current feedback amplifiers designed to operate over a wide supply range of $\pm V$ to $\pm 15\text{ V}$ for applications requiring large, linear output swings such as Arbitrary Waveform Generators.

The THS3095 features a power-down pin that puts the amplifier in low power standby mode, and lowers the quiescent current from 9.5 mA to 500 μA .

7.2 Feature Description

7.2.1 Saving Power With Power-Down Functionality and Setting Threshold Levels With the Reference Pin

The THS3095 features a power-down pin ($\overline{\text{PD}}$) which lowers the quiescent current from 9.5 mA down to 500 μA , ideal for reducing system power.

The power-down pin of the amplifier defaults to the positive supply voltage in the absence of an applied voltage, putting the amplifier in the power-on mode of operation. To turn off the amplifier in an effort to conserve power, the power-down pin can be driven towards the negative rail. The threshold voltages for power on and power down are relative to the supply rails and are given [Typical Characteristics \(\$\pm 15\text{ V}\$ \)](#) and [Typical Characteristics \(\$\pm 5\text{ V}\$ \)](#) tables. Above the Enable Threshold Voltage, the device is on. Below the Disable Threshold Voltage, the device is off. Behavior in between these threshold voltages is not specified.

Note that this power-down functionality is just that; the amplifier consumes less power in power-down mode. The power-down mode is not intended to provide a high-impedance output. In other words, the power-down functionality is not intended to allow use as a 3-state bus driver. When in power-down mode, the impedance looking back into the output of the amplifier is dominated by the feedback and gain-setting resistors, but the output impedance of the device itself varies depending on the voltage applied to the outputs.

[Figure 59](#) shows the total system output impedance which includes the amplifier output impedance in parallel with the feedback plus gain resistors, which cumulate to 2380 Ω . [Figure 60](#) shows this circuit configuration for reference.

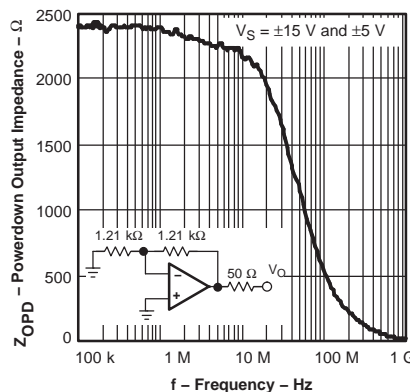

Figure 59. Power-Down Output Impedance vs Frequency

As with most current feedback amplifiers, the internal architecture places some limitations on the system when in power-down mode. Most notably is the fact that the amplifier actually turns *ON* if there is a $\pm 0.7\text{ V}$ or greater difference between the two input nodes (V_+ and V_-) of the amplifier. If this difference exceeds $\pm 0.7\text{ V}$, the output of the amplifier creates an output voltage equal to approximately $[(V_+ - V_-) - 0.7\text{ V}] \times \text{Gain}$. This also implies that if a voltage is applied to the output while in power-down mode, the V_- node voltage is equal to $V_{O(\text{applied})} \times R_G / (R_F + R_G)$. For low gain configurations and a large applied voltage at the output, the amplifier may actually turn *ON* due to the aforementioned behavior.

Feature Description (continued)

The time delays associated with turning the device on and off are specified as the time it takes for the amplifier to reach either 10% or 90% of the final output voltage. The time delays are in the order of microseconds because the amplifier moves in and out of the linear mode of operation in these transitions.

7.2.2 Power-Down Reference Pin Operation

In addition to the power-down pin, the THS3095 features a reference pin (REF) which allows the user to control the enable or disable power-down voltage levels applied to the \overline{PD} pin. In most split-supply applications, the reference pin is connected to ground. In either case, the user needs to be aware of voltage-level thresholds that apply to the power-down pin. The tables below show examples and illustrate the relationship between the reference voltage and the power-down thresholds. In the table, the threshold levels are derived by the following equations:

$$\overline{PD} \leq \text{REF} + 0.8 \text{ V for disable} \quad (1)$$

$$\overline{PD} \geq \text{REF} + 2.0 \text{ V for enable} \quad (2)$$

where the usable range at the REF pin is:

$$V_{S-} \leq V_{\text{REF}} \leq (V_{S+} - 4 \text{ V}). \quad (3)$$

The recommended mode of operation is to tie the REF pin to midrail, thus setting the enable/disable thresholds to $V_{\text{midrail}} + 2 \text{ V}$ and $V_{\text{midrail}} + 0.8 \text{ V}$ respectively.

Table 3. Power-Down Threshold Voltage Levels

SUPPLY VOLTAGE (V)	REFERENCE PIN VOLTAGE (V)	ENABLE LEVEL (V)	DISABLE LEVEL (V)
±15, ±5	0	2	0.8
±15	2	4	2.8
±15	-2	0	-1.2
±5	1	3	1.8
±5	-1	1	-0.2
30	15	17	15.8
10	5	7	5.8

Note that if the REF pin is left unterminated, it will float to the positive rail and will fall outside of the recommended operating range given above ($V_{S-} \leq V_{\text{REF}} \leq V_{S+} - 4 \text{ V}$). As a result, it will no longer serve as a reliable reference for the \overline{PD} pin and the enable/disable thresholds given above will no longer apply. If the \overline{PD} pin is also left unterminated, it will also float to the positive rail and the device will be enabled. If balanced, split supplies are used ($\pm V_s$) and the REF and \overline{PD} pins are grounded, the device will be disabled.

7.3 Device Functional Modes

7.3.1 Wideband, Noninverting Operation

The THS309x are unity gain stable 235-MHz current-feedback operational amplifiers, designed to operate from a $\pm 5\text{-V}$ to $\pm 15\text{-V}$ power supply.

Figure 60 shows the THS3091 in a noninverting gain of 2-V/V configuration typically used to generate the performance curves. Most of the curves were characterized using signal sources with 50-Ω source impedance, and with measurement equipment presenting a 50-Ω load impedance.

Device Functional Modes (continued)

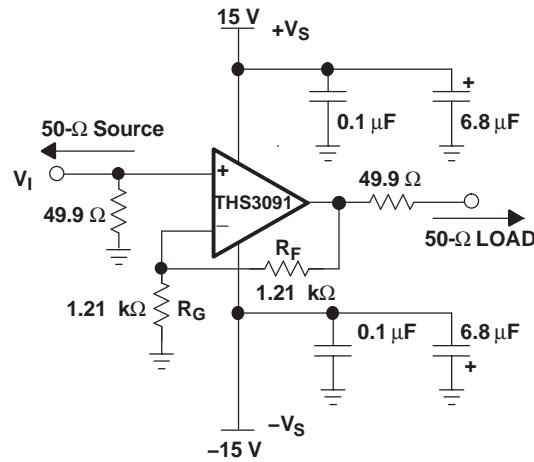

Figure 60. Wideband, Noninverting Gain Configuration

Current-feedback amplifiers are highly dependent on the feedback resistor R_F for maximum performance and stability. Table 4 shows the optimal gain-setting resistors R_F and R_G at different gains to give maximum bandwidth with minimal peaking in the frequency response. Higher bandwidths can be achieved, at the expense of added peaking in the frequency response, by using even lower values for R_F . Conversely, increasing R_F decreases the bandwidth, but stability is improved.

Table 4. Recommended Resistor Values for Optimum Frequency Response

THS3091 and THS3095 R_F and R_G values for minimal peaking with $R_L = 100 \Omega$			
GAIN (V/V)	SUPPLY VOLTAGE (V)	R_G (Ω)	R_F (Ω)
1	± 15	–	1.78 k
	± 5	–	1.78 k
2	± 15	1.21 k	1.21 k
	± 5	1.15 k	1.15 k
5	± 15	249	1 k
	± 5	249	1 k
10	± 15	95.3	866
	± 5	95.3	866
-1	± 15 and ± 5	1.05 k	1.05 k
-2	± 15 and ± 5	499	1 k
-5	± 15 and ± 5	182	909
-10	± 15 and ± 5	86.6	866

7.3.2 Wideband, Inverting Operation

Figure 61 shows the THS3091 in a typical inverting gain configuration where the input and output impedances and signal gain from Figure 60 are retained in an inverting circuit configuration.

Device Functional Modes (continued)

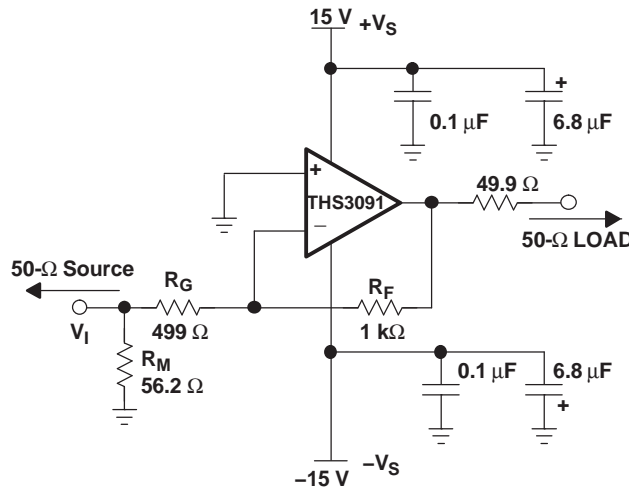

Figure 61. Wideband, Inverting Gain Configuration

7.3.3 Single-Supply Operation

The THS309x have the capability to operate from a single-supply voltage ranging from 10 V to 30 V. When operating from a single power supply, biasing the input and output at mid-supply allows for the maximum output voltage swing. The circuits shown in Figure 62 show inverting and noninverting amplifiers configured for single-supply operations.

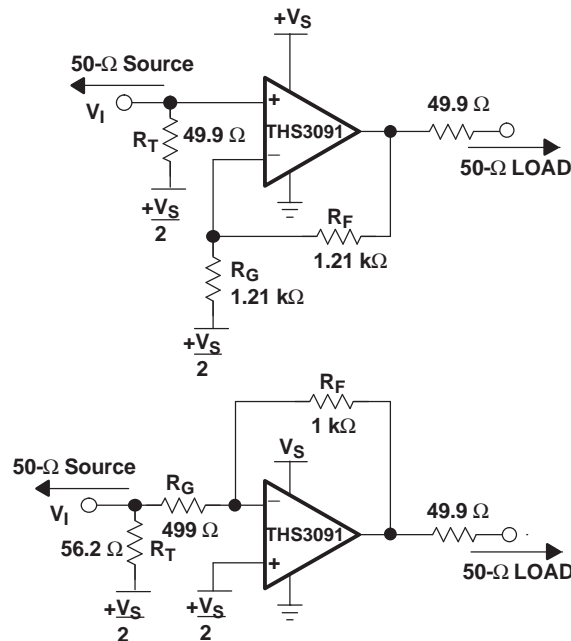

Figure 62. DC-Coupled, Single-Supply Operation

8 Application and Implementation

NOTE

Information in the following applications sections is not part of the TI component specification, and TI does not warrant its accuracy or completeness. TI's customers are responsible for determining suitability of components for their purposes. Customers should validate and test their design implementation to confirm system functionality.

8.1 Application Information

8.1.1 Video Distribution

The wide bandwidth, high slew rate, and high output drive current of the THS309x matches the demands for video distribution for delivering video signals down multiple cables. To ensure high signal quality with minimal degradation of performance, a 0.1-dB gain flatness should be at least 7x the passband frequency to minimize group delay variations from the amplifier. A high slew rate minimizes distortion of the video signal, and supports component video and RGB video signals that require fast transition times and fast settling times for high signal quality.

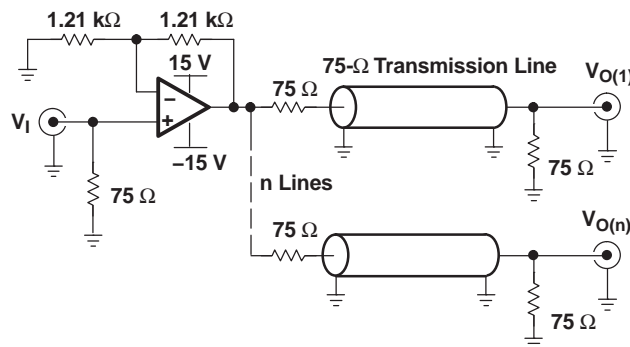

Figure 63. Video Distribution Amplifier Application

8.1.2 Driving Capacitive Loads

Applications such as FET line drivers can be highly capacitive and cause stability problems for high-speed amplifiers.

Figure 64 through Figure 69 show recommended methods for driving capacitive loads. The basic idea is to use a resistor or ferrite chip to isolate the phase shift at high frequency caused by the capacitive load from the amplifier's feedback path. See SLOA013 for recommended resistor values versus capacitive load.

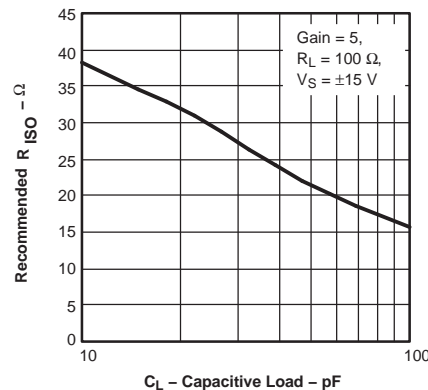
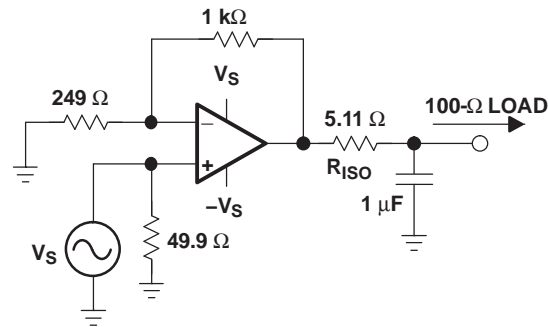
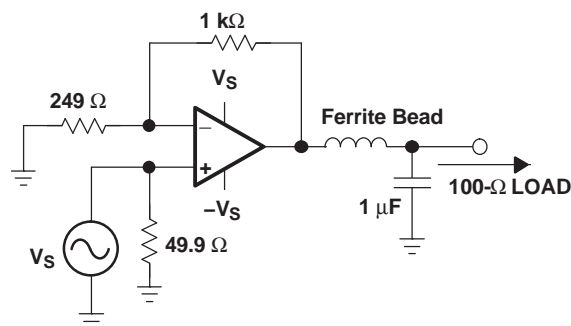

Figure 64. Recommended R_{ISO} vs Capacitive Load

Application Information (continued)

Figure 65. Driving a Large Capacitive Load Using an Output Series Isolation Resistor

Figure 66. Driving a Large Capacitive Load Using an Output Series Ferrite Bead

Placing a small series resistor, R_{ISO} , between the amplifier's output and the capacitive load, as shown in [Figure 65](#), is an easy way of isolating the load capacitance.

Using a ferrite chip in place of R_{ISO} , as shown in [Figure 66](#), is another approach of isolating the output of the amplifier. The ferrite's impedance characteristic versus frequency is useful to maintain the low-frequency load independence of the amplifier while isolating the phase shift caused by the capacitance at high frequency. Use a ferrite with similar impedance to R_{ISO} , 20 Ω to 50 Ω , at 100 MHz and low-impedance at DC.

[Figure 67](#) shows another method used to maintain the low-frequency load independence of the amplifier while isolating the phase shift caused by the capacitance at high frequency. At low frequency, feedback is mainly from the load side of R_{ISO} . At high frequency, the feedback is mainly via the 27-pF capacitor. The resistor R_{IN} in series with the negative input is used to stabilize the amplifier and should be equal to the recommended value of R_F at unity gain. Replacing R_{IN} with a ferrite of similar impedance at about 100 MHz as shown in [Figure 68](#) gives similar results with reduced DC offset and low-frequency noise. (See the [Related Documentation](#) section for expanding the usability of current-feedback amplifiers.)

Application Information (continued)

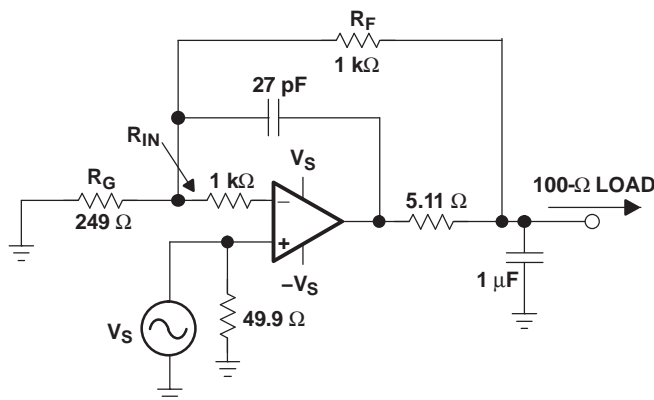

Figure 67. Driving a Large Capacitive Load Using a Multiple Feedback Loop With Stabilizing Input Resistor (R_{IN})

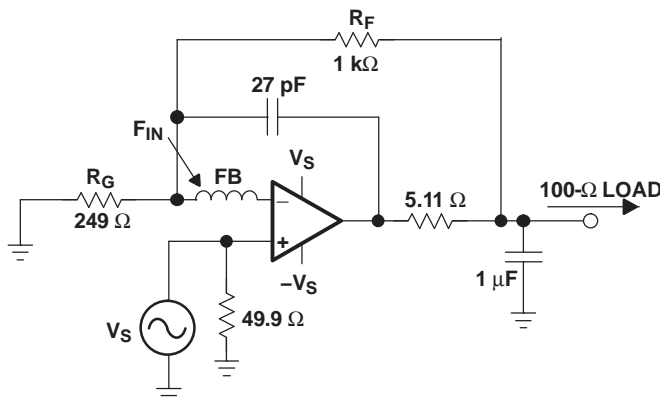

Figure 68. Driving a Large Capacitive Load Using a Multiple Feedback Loop With Stabilizing Input Ferrite Bead (F_{IN})

Figure 69 is shown using two amplifiers in parallel to double the output drive current to larger capacitive loads. This technique is used when more output current is needed to charge and discharge the load faster like when driving large FET transistors.

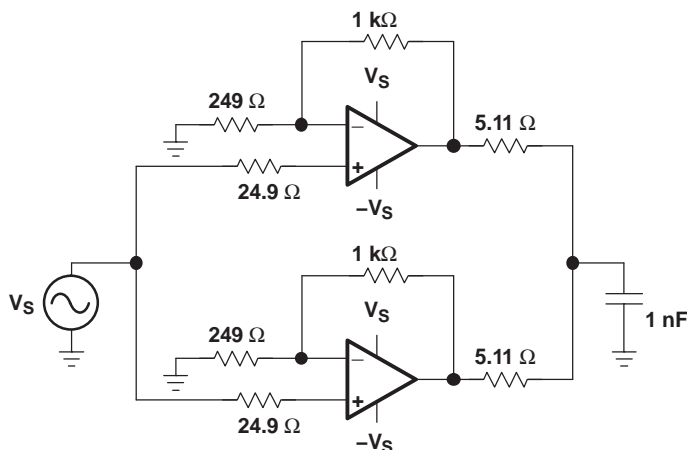

Figure 69. Driving a Large Capacitive Load Using 2 Parallel Amplifier Channels

Application Information (continued)

Figure 70 shows a push-pull FET driver circuit typical of ultrasound applications with isolation resistors to isolate the gate capacitance from the amplifier.

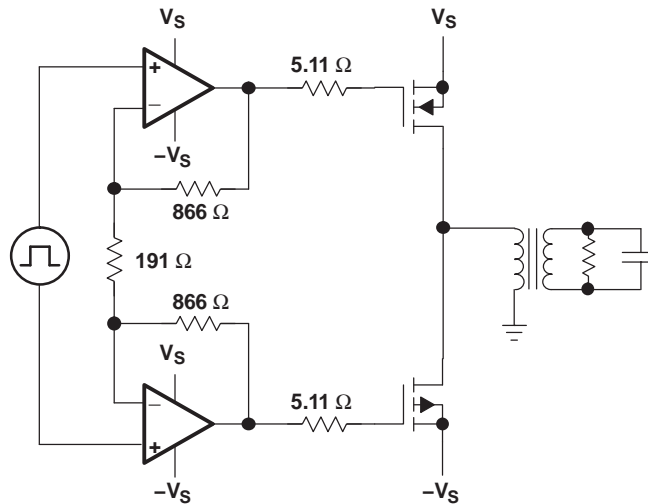

Figure 70. PowerFET Drive Circuit

8.2 Typical Application

The fundamental concept of load sharing is to drive a load using two or more of the same operational amplifiers. Each amplifier is driven by the same source. Figure 71 shows two THS3091 amplifiers sharing the same load. This concept effectively reduces the current load of each amplifier by $1/N$, where N is the number of amplifiers.

Typical Application (continued)

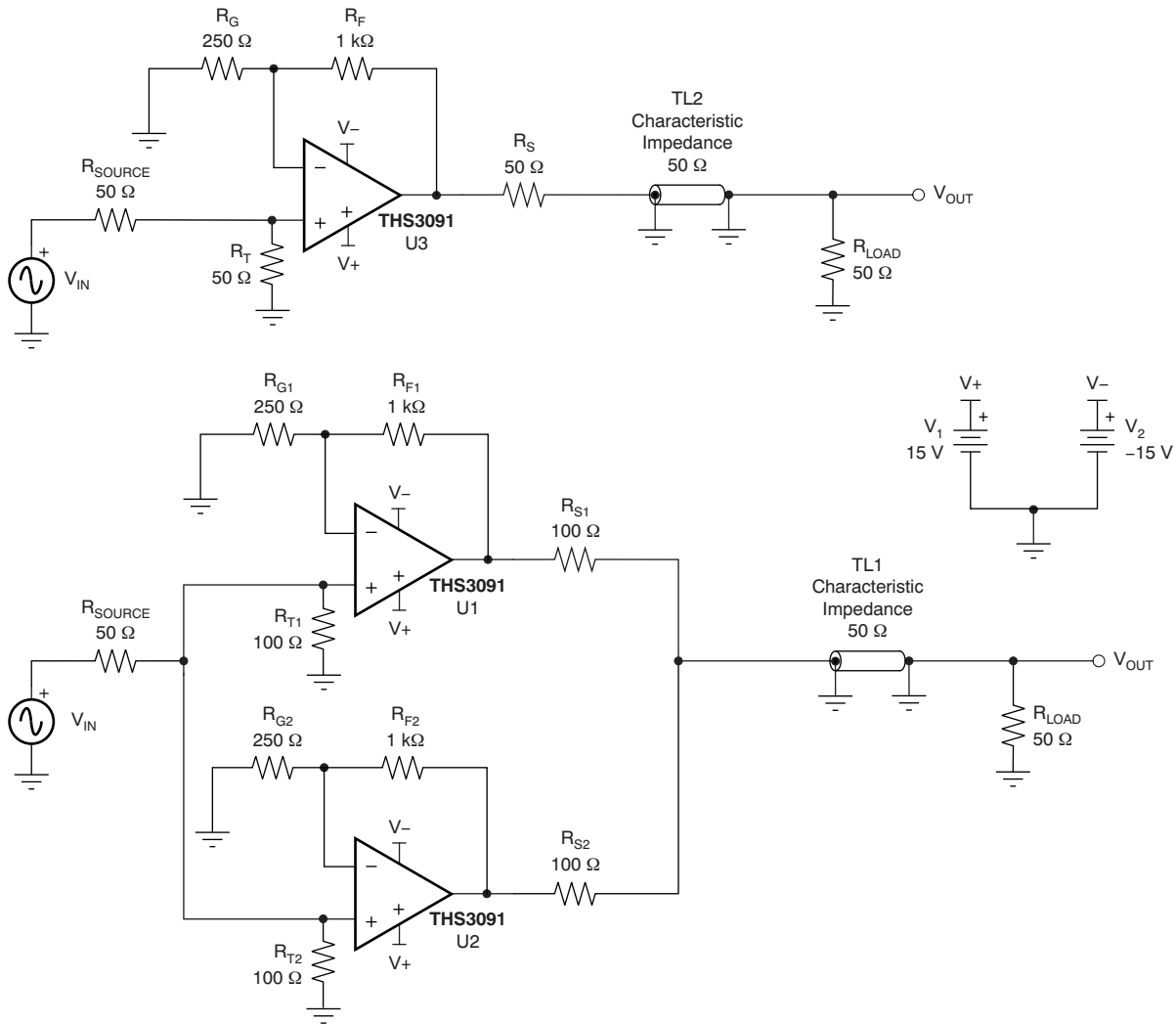

Figure 71. Reference THS3091 and THS3091 Load Sharing Test Configurations

8.2.1 Design Requirements

Use two THS3091 amplifiers in a parallel load-sharing circuit to improve distortion performance.

Table 5. Design Parameters

DESIGN PARAMETER	VALUE
V _{OPP}	20 V
R _{LOAD}	100 Ω

8.2.2 Detailed Design Procedure

In addition to providing higher output current drive to the load, the load sharing configuration can also provide improved distortion performance. In many cases, an operational amplifier shows better distortion performance as the load current decreases (that is, for higher resistive loads) until the feedback resistor starts to dominate the current load. In a load sharing configuration of N amplifiers in parallel, the equivalent current load that each amplifier drives is 1/N times the total load current. For example, in a two-amplifier load sharing configuration with

matching resistance (refer to [Figure 71](#)) driving a resistive load (RL), each series resistance is $2 \cdot RL$ and each amplifier drives $2 \cdot RL$. A convenient indicator of whether an op amp will function well in a load sharing configuration is the characteristic performance graph of harmonic distortion versus load resistance. Such graphs can be found in most of TI's high-speed amplifier data sheets. These graphs can be used to obtain a general sense of whether or not an amplifier will show improved distortion performance in load sharing configurations.

Two test circuits are shown in [Figure 71](#), one for a single THS3091 amplifier driving a double-terminated, 50-Ω cable and one with two THS3091 amplifiers in a load sharing configuration. In the load sharing configuration, the two 100-Ω series output resistors act in parallel to provide 50-Ω back-matching to the 50-Ω cable.

[Figure 72](#) and [Figure 73](#) show the 32-MHz, 18-VPP sine wave output amplitudes for the single THS3091 configuration and the load sharing configuration, respectively, measured using an oscilloscope. An ideal sine wave is also included as a visual reference (the dashed red line). [Figure 72](#) shows visible distortion in the single THS3091 output. In the load sharing configuration of [Figure 73](#), however, no obvious degradation is visible.

[Figure 74](#) and [Figure 75](#) show the 64-MHz sine wave outputs of the two configurations from [Figure 8](#). While the single THS3091 output is clearly distorted in [Figure 74](#), the output of the load sharing configuration in [Figure 75](#) shows only minor deviations from the ideal sine wave.

The improved output waveform as a result of load sharing is quantified in the harmonic distortion versus frequency graphs shown in [Figure 76](#) and [Figure 77](#) for the single amplifier and load sharing configurations, respectively. While second-harmonic distortion remains largely the same between the single and load sharing cases, third-harmonic distortion is improved by approximately 8 dB in the frequency range between 20 MHz to 64 MHz.

Table 6. Bill of Materials

THS3091DDA and THS3095DDA EVM ⁽¹⁾						
ITEM	DESCRIPTION	SMD SIZE	REFERENCE DESIGNATOR	PCB QTY	MANUFACTURER'S PART NUMBER	DISTRIBUTOR'S PART NUMBER
1	Bead, Ferrite, 3 A, 80 Ω	1206	FB1, FB2	2	(Steward) HI1206N800R-00	(Digi-Key) 240-1010-1-ND
2	Cap, 6.8 μF, Tantalum, 50 V, 10%	D	C3, C6	2	(AVX) TAJD685K050R	(Garrett) TAJD685K050R
3	Cap, 0.1 μF, ceramic, X7R, 50 V	0805	C9, C10	2 ⁽²⁾	(AVX) 08055C104KAT2A	(Garrett) 08055C104KAT2A
4	Cap, 0.1 μF, ceramic, X7R, 50 V	0805	C4, C7	2	(AVX) 08055C104KAT2A	(Garrett) 08055C104KAT2A
5	Resistor, 0 Ω, 1/8 W, 1%	0805	R9	1 ⁽²⁾	(KOA) RK73Z2ALTD	(Garrett) RK73Z2ALTD
6	Resistor, 249 Ω, 1/8 W, 1%	0805	R3	1	(KOA) RK73H2ALTD2490F	(Garrett) RK73H2ALTD2490F
7	Resistor, 1 kΩ, 1/8 W, 1%	0805	R4	1	(KOA) RK73H2ALTD1001F	(Garrett) RK73H2ALTD1001F
8	Open	1206	R8	1		
9	Resistor, 0 Ω, 1/4 W, 1%	1206	R1	1	(KOA) RK73Z2BLTD	(Garrett) RK73Z2BLTD
10	Resistor, 49.9 Ω, 1/4 W, 1%	1206	R2, R7	2	(KOA) RK73Z2BLTD49R9F	(Garrett) RK73Z2BLTD49R9F
11	Open	2512	R5, R6	2		
12	Header, 0.1-inch (2,54 mm) centers, 0.025-inch (6,35 mm) square pins		JP1, JP2	2 ⁽²⁾	(Sullins) PZC36SAAN	(Digi-Key) S1011-36-ND
13	Connector, SMA PCB Jack		J1, J2, J3	3	(Amphenol) 901-144-8RFX	(Newark) 01F2208
14	Jack, banana receptacle, 0.25-inch (6,35 mm) dia. hole		J4, J5, J6	3	(SPC) 813	(Newark) 39N867
15	Test point, black		TP1, TP2	2	(Keystone) 5001	(Digi-Key) 5001K-ND
16	Standoff, 4-40 hex, 0.625-inch (15,9 mm) length			4	(Keystone) 1808	(Newark) 89F1934
17	Screw, Phillips, 4-40, 0.25-inch (6,35 mm)			4	SHR-0440-016-SN	
18	IC, THS3091(3) IC, THS3095(2)		U1	1	(TI) THS3091DDA ⁽³⁾ (TI) THS3095DDA ⁽²⁾	
19	Board, printed-circuit			1	(TI) EDGE # 6446289 Rev. A ⁽³⁾ (TI) EDGE # 6446290 Rev. A ⁽²⁾	

(1) All items are designated for both the THS3091DDA and THS3095 EVMs unless otherwise noted.

(2) THS3095 EVM only.

(3) THS3091 EVM only.

8.2.3 Application Curves

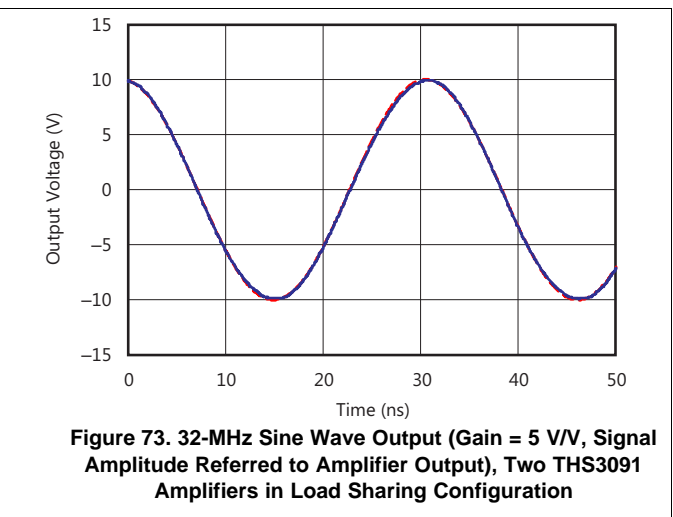
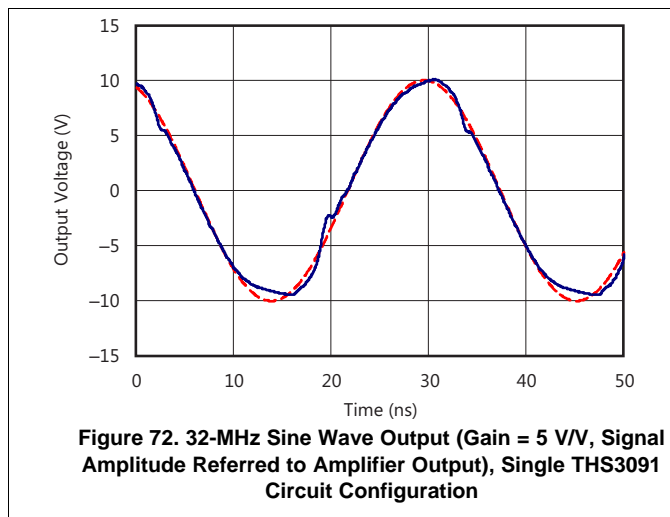

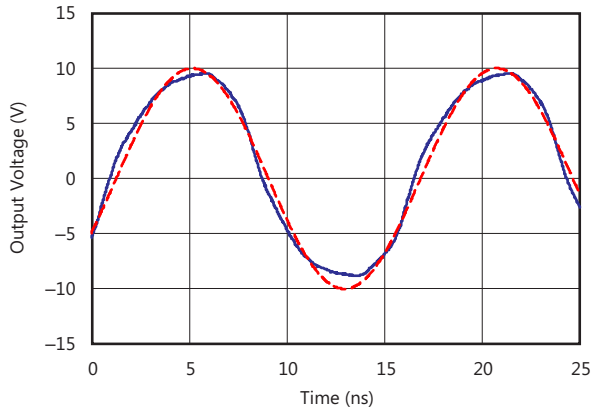

Figure 74. 64-MHz Sine Wave Output (Gain = 5 V/V, Signal Amplitude Referred to Amplifier Output), Single THS3091 Circuit Configuration

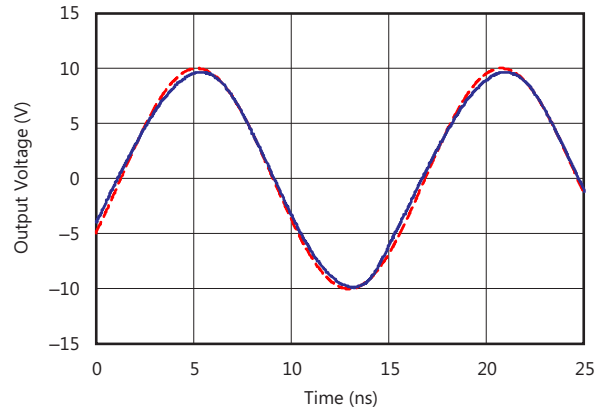

Figure 75. 64-MHz Sine Wave Output (Gain = 5 V/V, Signal Amplitude Referred to Amplifier Output), Two THS3091 Amplifiers in Load Sharing Configuration

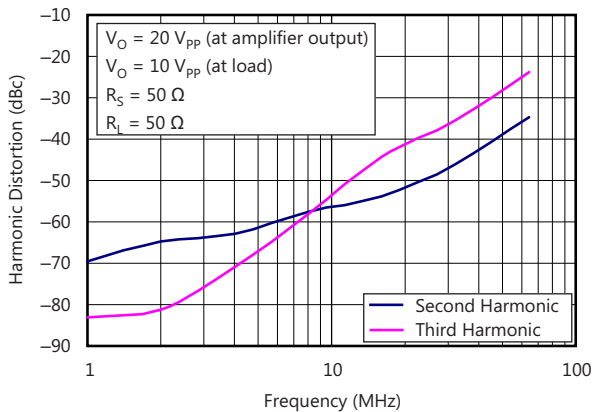

Figure 76. Harmonic Distortion vs Frequency, Single THS3091 Circuit Configuration

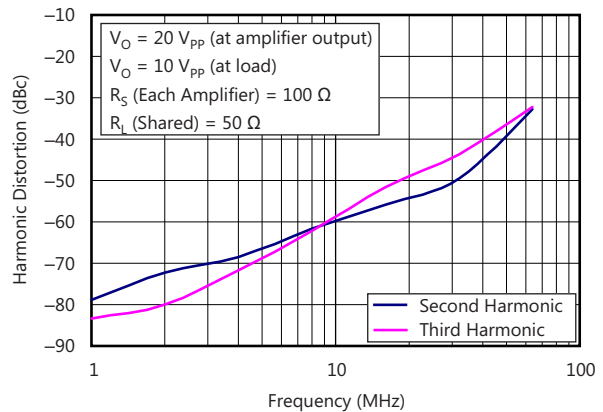

Figure 77. Harmonic Distortion vs Frequency, Two THS3091 Amplifiers in Load Sharing Configuration

9 Power Supply Recommendations

The THS3091 can operate off a single supply or with dual supplies as long as the input CM voltage range (CMIR) has the required headroom to either supply rail. Operating from a single supply can have numerous advantages. With the negative supply at ground, the DC errors due to the $-PSRR$ term can be minimized. Supplies should be decoupled with low inductance, often ceramic, capacitors to ground less than 0.5 inches from the device pins. The use of ground plane is recommended, and as in most high speed devices, it is advisable to remove ground plane close to device sensitive pins such as the inputs. An optional supply decoupling capacitor across the two power supplies (for split supply operation) improves second harmonic distortion performance.

10 Layout

10.1 Layout Guidelines

Achieving optimum performance with a high-frequency amplifier, like the THS309x, requires careful attention to board layout parasitic and external component types.

Recommendations that optimize performance include:

- Minimize parasitic capacitance to any ac ground for all of the signal I/O pins. Parasitic capacitance on the output and input pins can cause instability. To reduce unwanted capacitance, a window around the signal I/O pins should be opened in all of the ground and power planes around those pins. Otherwise, ground and power planes should be unbroken elsewhere on the board.
- Minimize the distance [< 0.25 inch (6.35 mm)] from the power supply pins to high-frequency 0.1- μ F and 100-pF decoupling capacitors. At the device pins, the ground and power plane layout should not be in close proximity to the signal I/O pins. Avoid narrow power and ground traces to minimize inductance between the pins and the decoupling capacitors. The power supply connections should always be decoupled with these capacitors. Larger (6.8 μ F or more) tantalum decoupling capacitors, effective at lower frequency, should also be used on the main supply pins. These may be placed somewhat farther from the device and may be shared among several devices in the same area of the PC board.
- Careful selection and placement of external components preserve the high-frequency performance of the THS309x. Resistors should be a low reactance type. Surface-mount resistors work best and allow a tighter overall layout. Again, keep their leads and PC board trace length as short as possible. Never use wire-bound type resistors in a high-frequency application. Because the output pin and inverting input pins are the most sensitive to parasitic capacitance, always position the feedback and series output resistors, if any, as close as possible to the inverting input pins and output pins. Other network components, such as input termination resistors, should be placed close to the gain-setting resistors. Even with a low parasitic capacitance shunting the external resistors, excessively high resistor values can create significant time constants that can degrade performance. Good axial metal-film or surface-mount resistors have approximately 0.2 pF in shunt with the resistor. For resistor values > 2 k Ω , this parasitic capacitance can add a pole and/or a zero that can effect circuit operation. Keep resistor values as low as possible, consistent with load-driving considerations.
- Connections to other wideband devices on the board may be made with short direct traces or through onboard transmission lines. For short connections, consider the trace and the input to the next device as a lumped capacitive load. Relatively wide traces [0.05 inch (1.3 mm) to 0.1 inch (2.54 mm)] should be used, preferably with ground and power planes opened up around them. Estimate the total capacitive load and determine if isolation resistors on the outputs are necessary. Low parasitic capacitive loads (< 4 pF) may not need an R_S because the THS309x are nominally compensated to operate with a 2-pF parasitic load. Higher parasitic capacitive loads without an R_S are allowed as the signal gain increases (increasing the unloaded phase margin). If a long trace is required, and the 6-dB signal loss intrinsic to a doubly terminated transmission line is acceptable, implement a matched impedance transmission line using microstrip or stripline techniques (consult an ECL design handbook for microstrip and stripline layout techniques). A 50- Ω environment is not necessary onboard, and in fact, a higher impedance environment improves distortion as shown in the distortion versus load plots. With a characteristic board trace impedance based on board material and trace dimensions, a matching series resistor into the trace from the output of the THS309x is used as well as a terminating shunt resistor at the input of the destination device. Remember also that the terminating impedance is the parallel combination of the shunt resistor and the input impedance of the destination device; this total effective impedance should be set to match the trace impedance. If the 6-dB attenuation of a doubly terminated transmission line is unacceptable, a long trace can be series-terminated at the source end only. Treat the trace as a capacitive load in this case. This does not preserve signal integrity as well as a doubly terminated line. If the input impedance of the destination device is low, there is some

Layout Guidelines (continued)

signal attenuation due to the voltage divider formed by the series output into the terminating impedance.

- Socketing a high-speed part like the THS309x is not recommended. The additional lead length and pin-to-pin capacitance introduced by the socket can create an extremely troublesome parasitic network which can make it almost impossible to achieve a smooth, stable frequency response. Best results are obtained by soldering the THS309x parts directly onto the board.

10.2 Layout Example

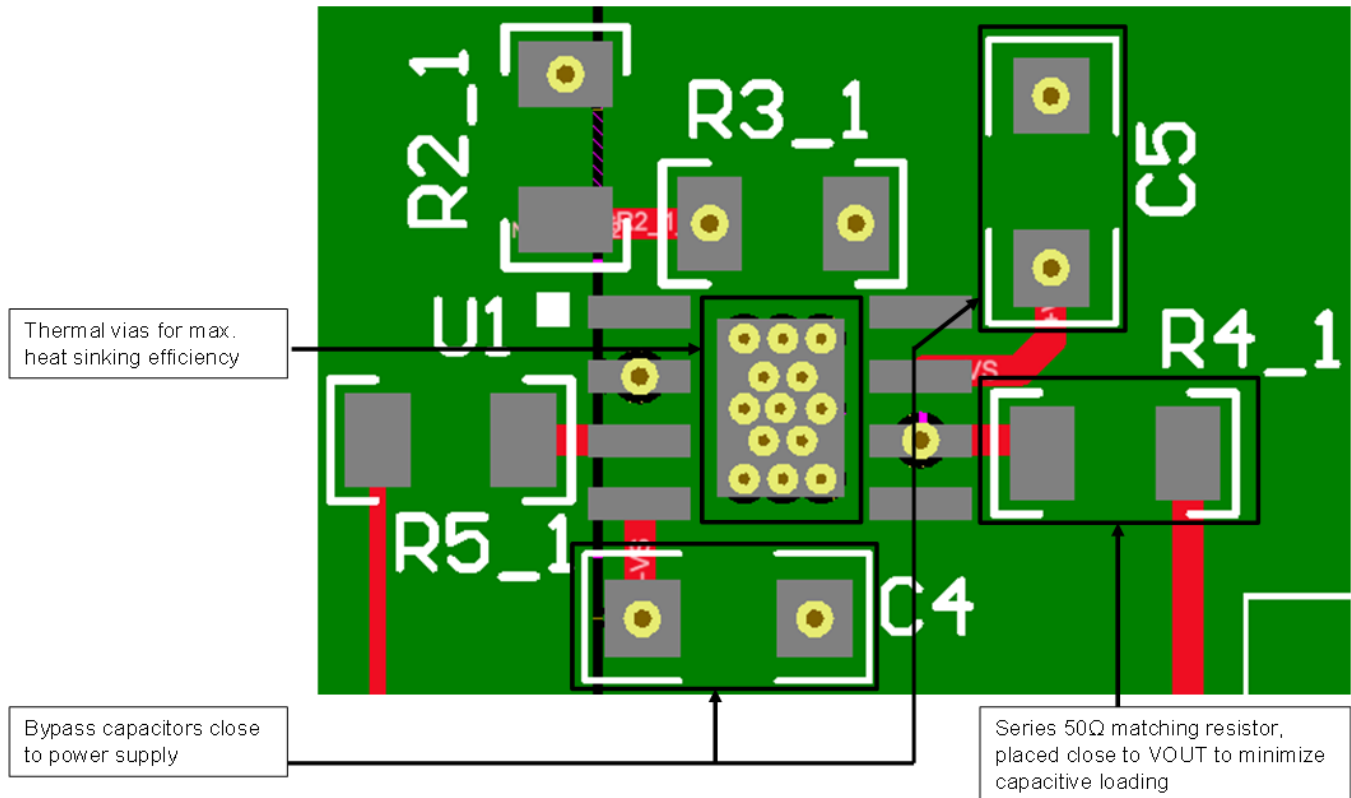

Figure 78. Layout Recommendation

Layout Example (continued)

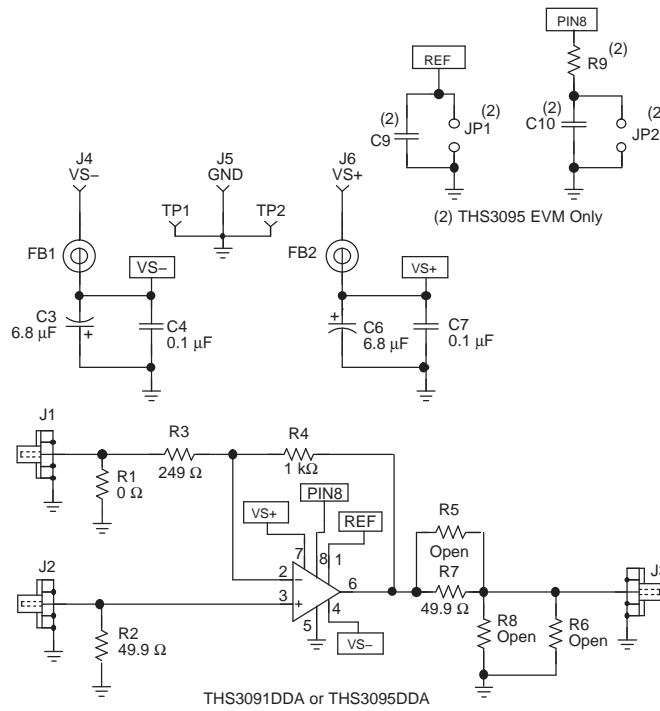

Figure 79. THS3091 EVM Circuit Configuration

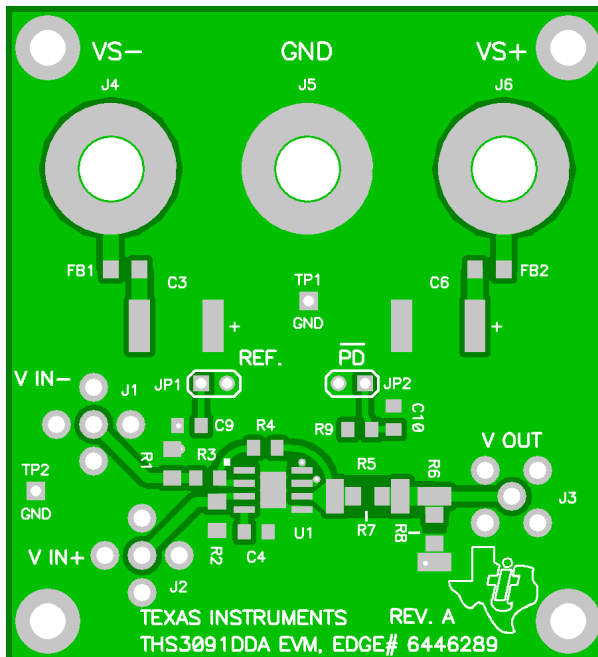

Figure 80. THS3091 EVM Board Layout (Top Layer)

Layout Example (continued)

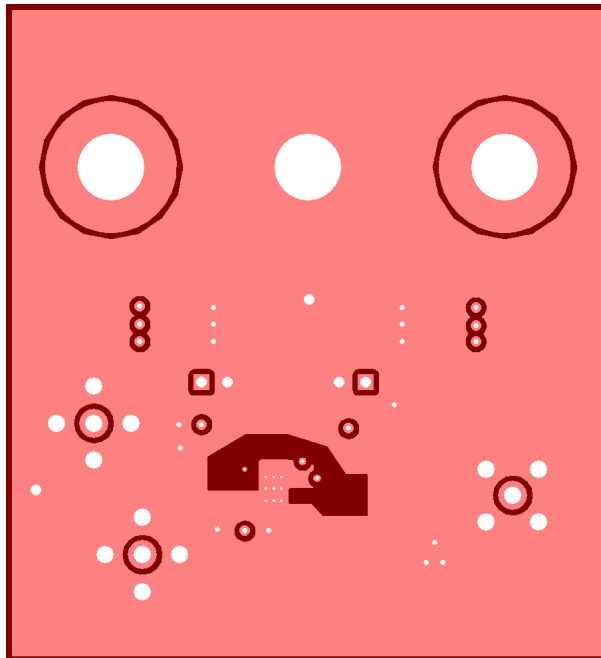

Figure 81. THS3091 EVM Board Layout (Second and Third Layers)

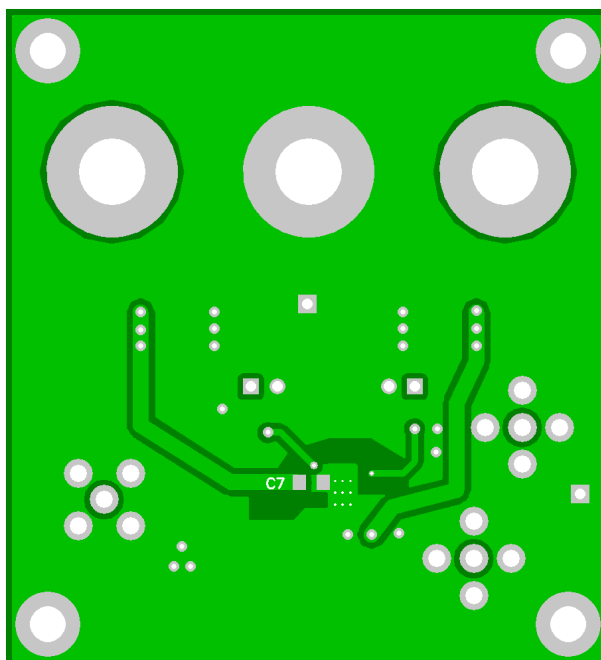

Figure 82. THS3091 EVM Board Layout (Bottom Layer)

10.3 PowerPAD Design Considerations

The THS309x are available in a thermally-enhanced PowerPAD family of packages. These packages are constructed using a downset leadframe on which the die is mounted [see Figure 83(a) and Figure 83(b)]. This arrangement results in the thermal pad being exposed as a thermal pad on the underside of the package [see Figure 83(c)]. Because this thermal pad has direct thermal contact with the die, excellent thermal performance can be achieved by providing a good thermal path away from the thermal pad. Note that devices such as the THS309x have no electrical connection between the PowerPAD and the die.

The PowerPAD package allows for both assembly and thermal management in one manufacturing operation. During the surface-mount solder operation (when the leads are being soldered), the thermal pad can also be soldered to a copper area underneath the package. Through the use of thermal paths within this copper area, heat can be conducted away from the package into either a ground plane or other heat-dissipating device.

The PowerPAD package represents a breakthrough in combining the small area and ease of assembly of surface mount with the, heretofore, awkward mechanical methods of heatsinking.

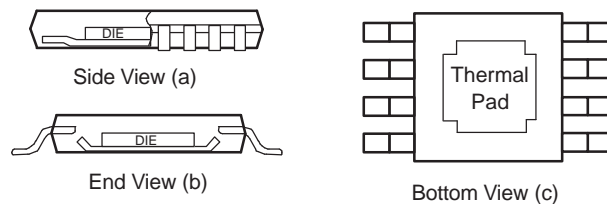

Figure 83. Views of Thermal Enhanced Package

Although there are many ways to properly heatsink the PowerPAD package, the following steps illustrate the recommended approach.

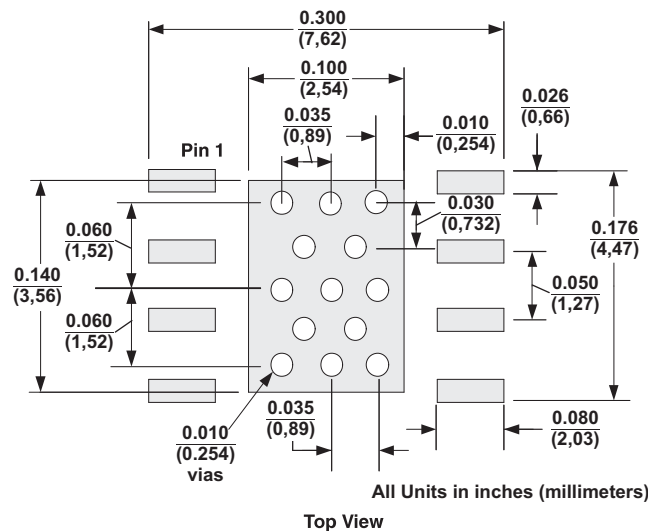

Figure 84. DDA PowerPAD PCB Etch and via Pattern

10.3.1 PowerPAD Layout Considerations

1. PCB with a top-side etch pattern is shown in Figure 84. There should be etch for the leads as well as etch for the thermal pad.
2. Place 13 holes in the area of the thermal pad. These holes should be 0.01 inch (0.254 mm) in diameter. Keep them small so that solder wicking through the holes is not a problem during reflow.
3. Additional vias may be placed anywhere along the thermal plane outside of the thermal pad area. This helps dissipate the heat generated by the THS309x IC. These additional vias may be larger than the 0.01-inch (0.254 mm) diameter vias directly under the thermal pad. They can be larger because they are not in the thermal pad area to be soldered so that wicking is not a problem.

PowerPAD Design Considerations (continued)

4. Connect all holes to the internal ground plane. Note that the PowerPAD is electrically isolated from the silicon and all leads. Connecting the PowerPAD to any potential voltage such as V_{S-} is acceptable as there is no electrical connection to the silicon.
5. When connecting these holes to the ground plane, do not use the typical web or spoke via connection methodology. Web connections have a high thermal resistance connection that is useful for slowing the heat transfer during soldering operations. This makes the soldering of vias that have plane connections easier. In this application, however, low thermal resistance is desired for the most efficient heat transfer. Therefore, the holes under the THS309x PowerPAD package should make their connection to the internal ground plane with a complete connection around the entire circumference of the plated-through hole.
6. The top-side solder mask should leave the terminals of the package and the thermal pad area with its 13 holes exposed. The bottom-side solder mask should cover the 13 holes of the thermal pad area. This prevents solder from being pulled away from the thermal pad area during the reflow process.
7. Apply solder paste to the exposed thermal pad area and all of the IC terminals.
8. With these preparatory steps in place, the IC is simply placed in position and run through the solder reflow operation as any standard surface-mount component. This results in a part that is properly installed.

10.3.2 Power Dissipation and Thermal Considerations

The THS309x incorporates automatic thermal shutoff protection. This protection circuitry shuts down the amplifier if the junction temperature exceeds approximately 160°C. When the junction temperature reduces to approximately 140°C, the amplifier turns on again. But, for maximum performance and reliability, the designer must ensure that the design does not exceed a junction temperature of 125°C. Between 125°C and 150°C, damage does not occur, but the performance of the amplifier begins to degrade and long-term reliability suffers. The thermal characteristics of the device are dictated by the package and the PC board. Maximum power dissipation for a given package can be calculated using the following formula.

$$P_{Dmax} = \frac{T_{max} - T_A}{\theta_{JA}}$$

where:

P_{Dmax} is the maximum power dissipation in the amplifier (W).

T_{max} is the absolute maximum junction temperature (°C).

T_A is the ambient temperature (°C).

$$\theta_{JA} = \theta_{JC} + \theta_{CA}$$

θ_{JC} is the thermal coefficient from the silicon junctions to the case (°C/W).

θ_{CA} is the thermal coefficient from the case to ambient air (°C/W).

(4)

For systems where heat dissipation is more critical, the THS3091 and THS3095 are offered in an 8-pin SOIC (DDA) with PowerPAD package. The thermal coefficient for the PowerPAD packages are substantially improved over the traditional SOIC. Maximum power dissipation levels are depicted in the graph for the available packages. The data for the PowerPAD packages assume a board layout that follows the PowerPAD layout guidelines referenced above and detailed in the PowerPAD application note ([SLMA002](#)). If the PowerPAD is not soldered to the PCB, the thermal impedance will increase substantially which may cause serious heat and performance issues. Be sure to always solder the PowerPAD to the PCB for optimum performance.

When determining whether or not the device satisfies the maximum power dissipation requirement, it is important to consider not only quiescent power dissipation, but also dynamic power dissipation. Often times, this is difficult to quantify because the signal pattern is inconsistent, but an estimate of the RMS power dissipation can provide visibility into a possible problem.

11 Device and Documentation Support

11.1 Device Support

11.1.1 Development Support

11.1.1.1 Evaluation Fixtures, Spice Models, and Application Support

Texas Instruments is committed to providing its customers with the highest quality of applications support. To support this goal, an evaluation board has been developed for the THS309x operational amplifier. The board is easy to use, allowing for straightforward evaluation of the device. The evaluation board can be ordered through the Texas Instruments Web site, www.ti.com, or through your local Texas Instruments sales representative.

Computer simulation of circuit performance using SPICE is often useful when analyzing the performance of analog circuits and systems. This is particularly true for video and RF-amplifier circuits where parasitic capacitance and inductance can have a major effect on circuit performance. A SPICE model for the THS309x is available through the Texas Instruments Web site (www.ti.com). The Product Information Center (PIC) is also available for design assistance and detailed product information. These models do a good job of predicting small-signal ac and transient performance under a wide variety of operating conditions. They are not intended to model the distortion characteristics of the amplifier, nor do they attempt to distinguish between the package types in their small-signal ac performance. Detailed information about what is and is not modeled is contained in the model file itself.

11.2 Documentation Support

11.2.1 Related Documentation

For related documentation, see the following:

- PowerPAD™ Made Easy, application brief ([SLMA004](#))
- PowerPAD™ Thermally Enhanced Package, technical brief ([SLMA002](#))
- Voltage Feedback vs Current Feedback Amplifiers, ([SLVA051](#))
- Current Feedback Analysis and Compensation ([SLOA021](#))
- Current Feedback Amplifiers: Review, Stability, and Application ([SBOA081](#))
- Effect of Parasitic Capacitance in Op Amp Circuits ([SLOA013](#))
- Expanding the Usability of Current-Feedback Amplifiers, 3Q 2003 Analog Applications Journal.

11.3 Related Links

The table below lists quick access links. Categories include technical documents, support and community resources, tools and software, and quick access to sample or buy.

Table 7. Related Links

PARTS	PRODUCT FOLDER	SAMPLE & BUY	TECHNICAL DOCUMENTS	TOOLS & SOFTWARE	SUPPORT & COMMUNITY
THS3091	Click here	Click here	Click here	Click here	Click here
THS3095	Click here	Click here	Click here	Click here	Click here

11.4 Community Resources

The following links connect to TI community resources. Linked contents are provided "AS IS" by the respective contributors. They do not constitute TI specifications and do not necessarily reflect TI's views; see TI's [Terms of Use](#).

TI E2E™ Online Community *TI's Engineer-to-Engineer (E2E) Community*. Created to foster collaboration among engineers. At e2e.ti.com, you can ask questions, share knowledge, explore ideas and help solve problems with fellow engineers.

Design Support *TI's Design Support* Quickly find helpful E2E forums along with design support tools and contact information for technical support.

11.5 Trademarks

PowerPAD, E2E are trademarks of Texas Instruments.
All other trademarks are the property of their respective owners.

11.6 Electrostatic Discharge Caution



These devices have limited built-in ESD protection. The leads should be shorted together or the device placed in conductive foam during storage or handling to prevent electrostatic damage to the MOS gates.

11.7 Glossary

[SLYZ022](#) — *TI Glossary*.

This glossary lists and explains terms, acronyms, and definitions.

12 Mechanical, Packaging, and Orderable Information

The following pages include mechanical, packaging, and orderable information. This information is the most current data available for the designated devices. This data is subject to change without notice and revision of this document. For browser-based versions of this data sheet, refer to the left-hand navigation.

PACKAGING INFORMATION

Orderable Device	Status (1)	Package Type	Package Drawing	Pins	Package Qty	Eco Plan (2)	Lead/Ball Finish (6)	MSL Peak Temp (3)	Op Temp (°C)	Device Marking (4/5)	Samples
THS3091D	ACTIVE	SOIC	D	8	75	Green (RoHS & no Sb/Br)	CU NIPDAU	Level-1-260C-UNLIM	-40 to 85	3091	Samples
THS3091DDA	ACTIVE	SO PowerPAD	DDA	8	75	Green (RoHS & no Sb/Br)	CU SN	Level-1-260C-UNLIM	-40 to 85	3091	Samples
THS3091DDAG3	ACTIVE	SO PowerPAD	DDA	8	75	Green (RoHS & no Sb/Br)	CU SN	Level-1-260C-UNLIM	-40 to 85	3091	Samples
THS3091DDAR	ACTIVE	SO PowerPAD	DDA	8	2500	Green (RoHS & no Sb/Br)	CU SN	Level-1-260C-UNLIM	-40 to 85	3091	Samples
THS3091DDARG3	ACTIVE	SO PowerPAD	DDA	8	2500	Green (RoHS & no Sb/Br)	CU SN	Level-1-260C-UNLIM	-40 to 85	3091	Samples
THS3091DR	ACTIVE	SOIC	D	8	2500	Green (RoHS & no Sb/Br)	CU NIPDAU	Level-1-260C-UNLIM	-40 to 85	3091	Samples
THS3095D	ACTIVE	SOIC	D	8	75	Green (RoHS & no Sb/Br)	CU NIPDAU	Level-1-260C-UNLIM	-40 to 85	3095	Samples
THS3095DDA	ACTIVE	SO PowerPAD	DDA	8	75	Green (RoHS & no Sb/Br)	CU SN	Level-1-260C-UNLIM	-40 to 85	3095	Samples
THS3095DDAR	ACTIVE	SO PowerPAD	DDA	8	2500	Green (RoHS & no Sb/Br)	CU SN	Level-1-260C-UNLIM	-40 to 85	3095	Samples

(1) The marketing status values are defined as follows:

ACTIVE: Product device recommended for new designs.

LIFEBUY: TI has announced that the device will be discontinued, and a lifetime-buy period is in effect.

NRND: Not recommended for new designs. Device is in production to support existing customers, but TI does not recommend using this part in a new design.

PREVIEW: Device has been announced but is not in production. Samples may or may not be available.

OBSOLETE: TI has discontinued the production of the device.

(2) **RoHS:** TI defines "RoHS" to mean semiconductor products that are compliant with the current EU RoHS requirements for all 10 RoHS substances, including the requirement that RoHS substance do not exceed 0.1% by weight in homogeneous materials. Where designed to be soldered at high temperatures, "RoHS" products are suitable for use in specified lead-free processes. TI may reference these types of products as "Pb-Free".

RoHS Exempt: TI defines "RoHS Exempt" to mean products that contain lead but are compliant with EU RoHS pursuant to a specific EU RoHS exemption.

Green: TI defines "Green" to mean the content of Chlorine (Cl) and Bromine (Br) based flame retardants meet JS709B low halogen requirements of <=1000ppm threshold. Antimony trioxide based flame retardants must also meet the <=1000ppm threshold requirement.

(3) MSL, Peak Temp. - The Moisture Sensitivity Level rating according to the JEDEC industry standard classifications, and peak solder temperature.

(4) There may be additional marking, which relates to the logo, the lot trace code information, or the environmental category on the device.

(5) Multiple Device Markings will be inside parentheses. Only one Device Marking contained in parentheses and separated by a "~" will appear on a device. If a line is indented then it is a continuation of the previous line and the two combined represent the entire Device Marking for that device.

(6) Lead/Ball Finish - Orderable Devices may have multiple material finish options. Finish options are separated by a vertical ruled line. Lead/Ball Finish values may wrap to two lines if the finish value exceeds the maximum column width.

Important Information and Disclaimer:The information provided on this page represents TI's knowledge and belief as of the date that it is provided. TI bases its knowledge and belief on information provided by third parties, and makes no representation or warranty as to the accuracy of such information. Efforts are underway to better integrate information from third parties. TI has taken and continues to take reasonable steps to provide representative and accurate information but may not have conducted destructive testing or chemical analysis on incoming materials and chemicals. TI and TI suppliers consider certain information to be proprietary, and thus CAS numbers and other limited information may not be available for release.

In no event shall TI's liability arising out of such information exceed the total purchase price of the TI part(s) at issue in this document sold by TI to Customer on an annual basis.

TAPE AND REEL INFORMATION



QUADRANT ASSIGNMENTS FOR PIN 1 ORIENTATION IN TAPE



*All dimensions are nominal

Device	Package Type	Package Drawing	Pins	SPQ	Reel Diameter (mm)	Reel Width W1 (mm)	A0 (mm)	B0 (mm)	K0 (mm)	P1 (mm)	W (mm)	Pin1 Quadrant
THS3091DDAR	SO Power PAD	DDA	8	2500	330.0	12.4	6.4	5.2	2.1	8.0	12.0	Q1
THS3091DR	SOIC	D	8	2500	330.0	12.4	6.4	5.2	2.1	8.0	12.0	Q1
THS3095DDAR	SO Power PAD	DDA	8	2500	330.0	12.4	6.4	5.2	2.1	8.0	12.0	Q1

TAPE AND REEL BOX DIMENSIONS

*All dimensions are nominal

Device	Package Type	Package Drawing	Pins	SPQ	Length (mm)	Width (mm)	Height (mm)
THS3091DDAR	SO PowerPAD	DDA	8	2500	350.0	350.0	43.0
THS3091DR	SOIC	D	8	2500	350.0	350.0	43.0
THS3095DDAR	SO PowerPAD	DDA	8	2500	350.0	350.0	43.0

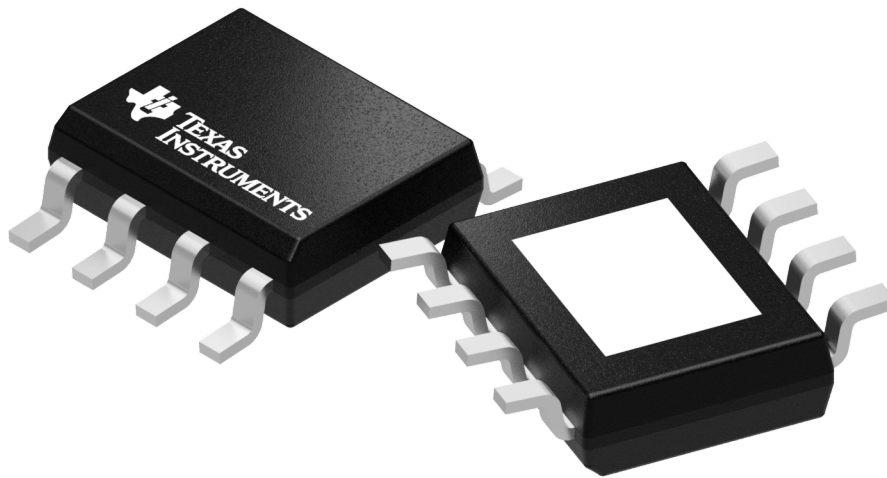

Images above are just a representation of the package family, actual package may vary.
Refer to the product data sheet for package details.

DDA (R-PDSO-G8)

PowerPAD™ PLASTIC SMALL-OUTLINE

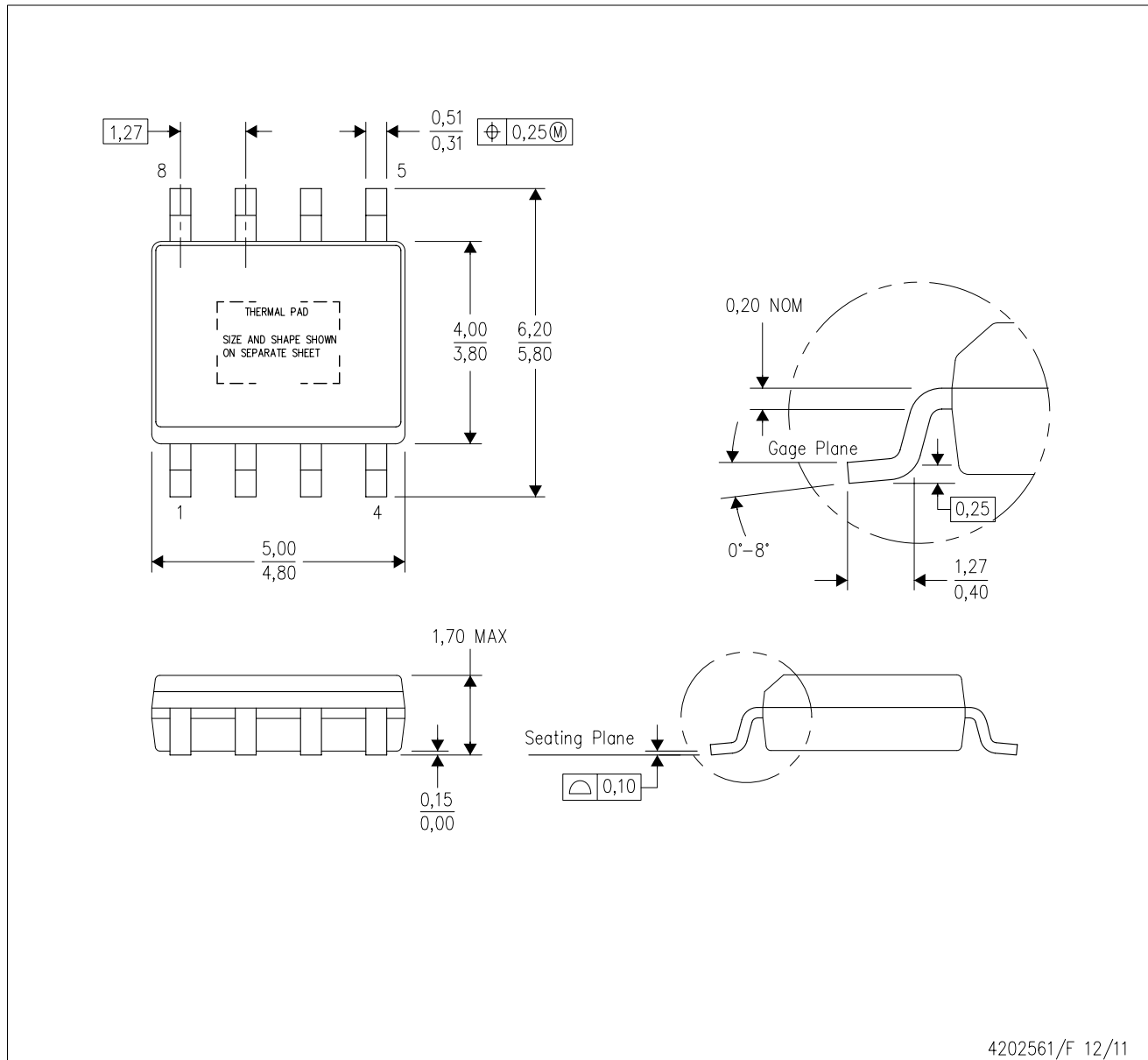

4202561/F 12/11

- NOTES:
- A. All linear dimensions are in millimeters. Dimensioning and tolerancing per ASME Y14.5-1994.
 - B. This drawing is subject to change without notice.
 - C. Body dimensions do not include mold flash or protrusion not to exceed 0,15.
 - D. This package is designed to be soldered to a thermal pad on the board. Refer to Technical Brief, PowerPad Thermally Enhanced Package, Texas Instruments Literature No. SLMA002 for information regarding recommended board layout. This document is available at www.ti.com <<http://www.ti.com>>.
 - E. See the additional figure in the Product Data Sheet for details regarding the exposed thermal pad features and dimensions.
 - F. This package complies to JEDEC MS-012 variation BA

PowerPAD is a trademark of Texas Instruments.

DDA (R-PDSO-G8)

PowerPAD™ PLASTIC SMALL OUTLINE

THERMAL INFORMATION

This PowerPAD™ package incorporates an exposed thermal pad that is designed to be attached to a printed circuit board (PCB). The thermal pad must be soldered directly to the PCB. After soldering, the PCB can be used as a heatsink. In addition, through the use of thermal vias, the thermal pad can be attached directly to the appropriate copper plane shown in the electrical schematic for the device, or alternatively, can be attached to a special heatsink structure designed into the PCB. This design optimizes the heat transfer from the integrated circuit (IC).

For additional information on the PowerPAD package and how to take advantage of its heat dissipating abilities, refer to Technical Brief, PowerPAD Thermally Enhanced Package, Texas Instruments Literature No. SLMA002 and Application Brief, PowerPAD Made Easy, Texas Instruments Literature No. SLMA004. Both documents are available at www.ti.com.

The exposed thermal pad dimensions for this package are shown in the following illustration.

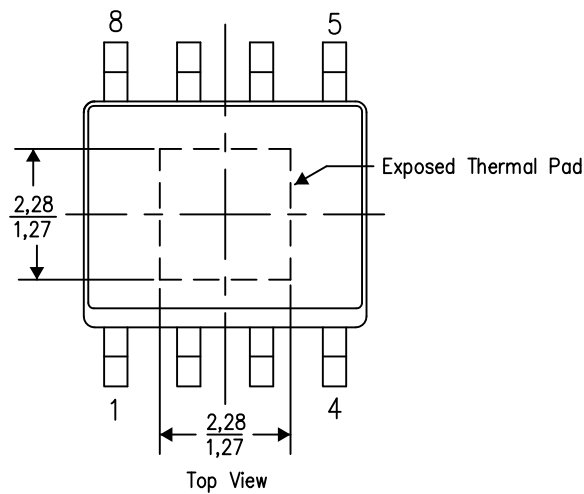

Exposed Thermal Pad Dimensions

4206322-2/L 05/12

NOTE: A. All linear dimensions are in millimeters

PowerPAD is a trademark of Texas Instruments

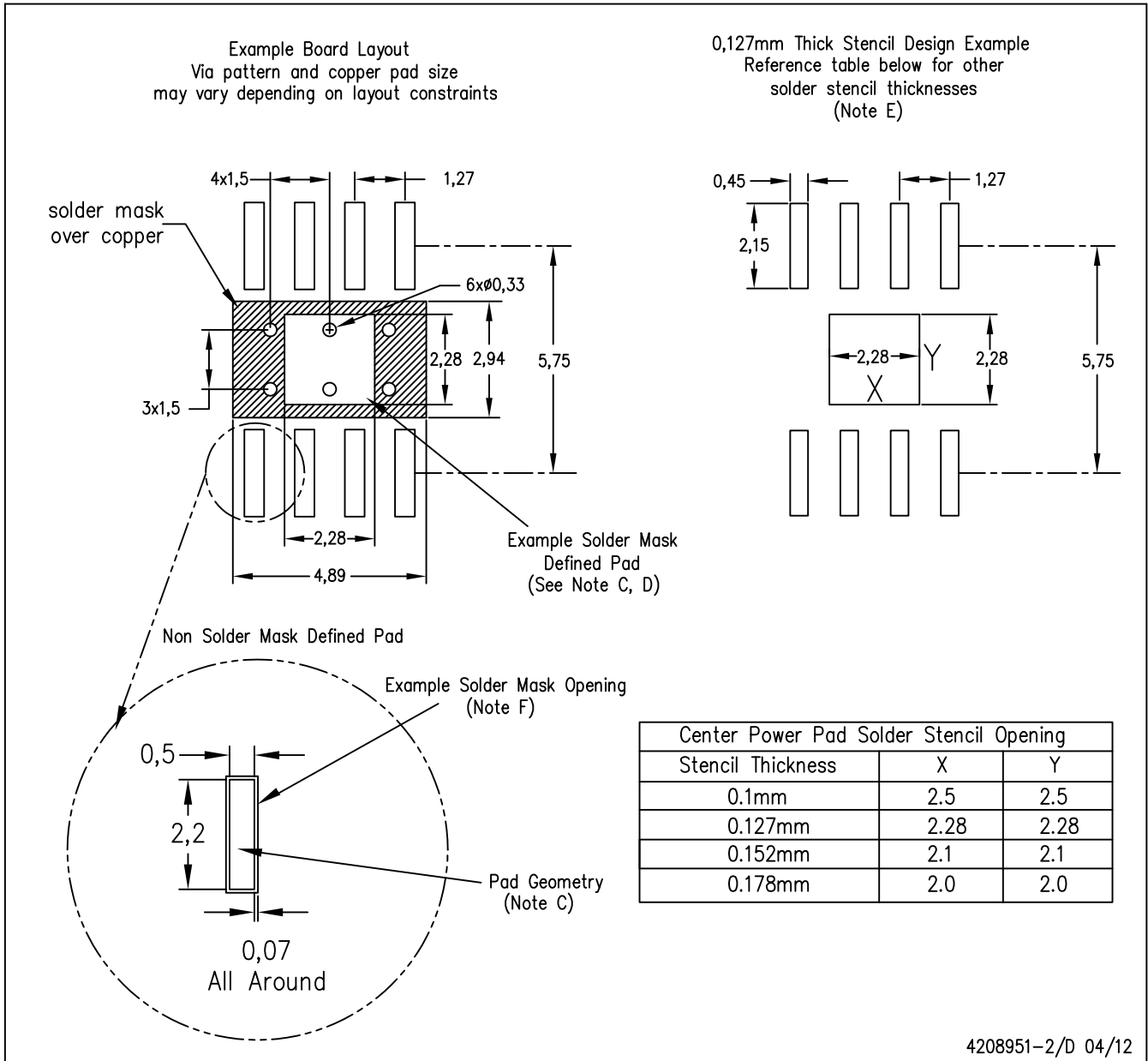

4208951-2/D 04/12

- NOTES:
- A. All linear dimensions are in millimeters.
 - B. This drawing is subject to change without notice.
 - C. Publication IPC-7351 is recommended for alternate designs.
 - D. This package is designed to be soldered to a thermal pad on the board. Refer to Technical Brief, PowerPAD Thermally Enhanced Package, Texas Instruments Literature No. SLMA002, SLMA004, and also the Product Data Sheets for specific thermal information, via requirements, and recommended board layout. These documents are available at www.ti.com <<http://www.ti.com>>. Publication IPC-7351 is recommended for alternate designs.
 - E. Laser cutting apertures with trapezoidal walls and also rounding corners will offer better paste release. Customers should contact their board assembly site for stencil design recommendations. Example stencil design based on a 50% volumetric metal load solder paste. Refer to IPC-7525 for other stencil recommendations.
 - F. Customers should contact their board fabrication site for solder mask tolerances between and around signal pads.

PowerPAD is a trademark of Texas Instruments.



D0008A

PACKAGE OUTLINE

SOIC - 1.75 mm max height

SMALL OUTLINE INTEGRATED CIRCUIT



4214825/C 02/2019

NOTES:

1. Linear dimensions are in inches [millimeters]. Dimensions in parenthesis are for reference only. Controlling dimensions are in inches. Dimensioning and tolerancing per ASME Y14.5M.
2. This drawing is subject to change without notice.
3. This dimension does not include mold flash, protrusions, or gate burrs. Mold flash, protrusions, or gate burrs shall not exceed $.006$ [0.15] per side.
4. This dimension does not include interlead flash.
5. Reference JEDEC registration MS-012, variation AA.

EXAMPLE BOARD LAYOUT

D0008A

SOIC - 1.75 mm max height

SMALL OUTLINE INTEGRATED CIRCUIT



LAND PATTERN EXAMPLE
 EXPOSED METAL SHOWN
 SCALE:8X



SOLDER MASK DETAILS

4214825/C 02/2019

NOTES: (continued)

- 6. Publication IPC-7351 may have alternate designs.
- 7. Solder mask tolerances between and around signal pads can vary based on board fabrication site.

EXAMPLE STENCIL DESIGN

D0008A

SOIC - 1.75 mm max height

SMALL OUTLINE INTEGRATED CIRCUIT



SOLDER PASTE EXAMPLE
BASED ON .005 INCH [0.125 MM] THICK STENCIL
SCALE:8X

4214825/C 02/2019

NOTES: (continued)

8. Laser cutting apertures with trapezoidal walls and rounded corners may offer better paste release. IPC-7525 may have alternate design recommendations.
9. Board assembly site may have different recommendations for stencil design.

IMPORTANT NOTICE AND DISCLAIMER

TI PROVIDES TECHNICAL AND RELIABILITY DATA (INCLUDING DATASHEETS), DESIGN RESOURCES (INCLUDING REFERENCE DESIGNS), APPLICATION OR OTHER DESIGN ADVICE, WEB TOOLS, SAFETY INFORMATION, AND OTHER RESOURCES "AS IS" AND WITH ALL FAULTS, AND DISCLAIMS ALL WARRANTIES, EXPRESS AND IMPLIED, INCLUDING WITHOUT LIMITATION ANY IMPLIED WARRANTIES OF MERCHANTABILITY, FITNESS FOR A PARTICULAR PURPOSE OR NON-INFRINGEMENT OF THIRD PARTY INTELLECTUAL PROPERTY RIGHTS.

These resources are intended for skilled developers designing with TI products. You are solely responsible for (1) selecting the appropriate TI products for your application, (2) designing, validating and testing your application, and (3) ensuring your application meets applicable standards, and any other safety, security, or other requirements. These resources are subject to change without notice. TI grants you permission to use these resources only for development of an application that uses the TI products described in the resource. Other reproduction and display of these resources is prohibited. No license is granted to any other TI intellectual property right or to any third party intellectual property right. TI disclaims responsibility for, and you will fully indemnify TI and its representatives against, any claims, damages, costs, losses, and liabilities arising out of your use of these resources.

TI's products are provided subject to TI's Terms of Sale (www.ti.com/legal/termsofsale.html) or other applicable terms available either on ti.com or provided in conjunction with such TI products. TI's provision of these resources does not expand or otherwise alter TI's applicable warranties or warranty disclaimers for TI products.

Mailing Address: Texas Instruments, Post Office Box 655303, Dallas, Texas 75265
Copyright © 2019, Texas Instruments Incorporated

Looking for pricing, stock, or lifecycle information?

Click below to explore more details on WIN SOURCE:

 [View THS3091DR on WIN SOURCE](#)

 [Texas Instruments](#) Information

Optimize Your Supply Chain with WIN SOURCE Solutions

-  Global Sourcing Solution
-  Obsolete Management
-  Cost Control Management
-  Shortage Management
-  Alternative Solution
-  Excess Inventory Management