



**THE DATASHEET OF
ADS62C15IRGCR**



Dual Channel 11-Bits, 125 MSPS ADC With Parallel CMOS/DDR LVDS Outputs

Check for Samples: [ADS62P15](#)

FEATURES

- **Maximum Sample Rate: 125 MSPS**
- **11-Bit Resolution With No Missing Codes**
- **84 dBc SFDR at $F_{in} = 50$ MHz**
- **67.1 dBFS SNR at $F_{in} = 50$ MHz**
- **92 dB Crosstalk**
- **Parallel CMOS and DDR LVDS Output Options**
- **3.5 dB Coarse Gain and Programmable Fine Gain up to 6 dB for SNR/SFDR Trade-Off**
- **Digital Processing Block With:**
 - Offset Correction
 - Fine Gain Correction, in Steps of 0.05 dB
 - Decimation by 2/4/8
 - Built-in and Custom Programmable 24-Tap Low/High /Band Pass Filters
- **Supports Sine, LVPECL, LVDS & LVCMOS Clocks & Amplitude Down to 400 mV_{PP}**
- **Clock Duty Cycle Stabilizer**
- **Internal Reference; Supports External**

Reference also

- **64-QFN Package (9mm × 9mm)**
- **Pin Compatible 14-bit and 12-bit Family (ADS62P4X/ADS62P2X)**

APPLICATIONS

- **Wireless Communications Infrastructure**
- **Software Defined Radio**
- **Power Amplifier Linearization**
- **802.16d/e**
- **Medical Imaging**
- **Radar Systems**
- **Test and Measurement Instrumentation**

Table 1. ADS62PXX Dual Channel Family

| | 125 MSPS | 105 MSPS | 80 MSPS | 65 MSPS |
|--------------------------|----------|----------|----------|----------|
| ADS62P4X (14 bit) | ADS62P45 | ADS62P44 | ADS62P43 | ADS62P42 |
| ADS62P2X (12 bit) | ADS62P25 | ADS62P24 | ADS62P23 | ADS62P22 |
| (11 bit) | ADS62P15 | - | - | - |

DESCRIPTION

ADS62P15 is a dual channel 11-bit A/D converter with maximum sample rates up to 125 MSPS. It combines high performance and low power consumption in a compact 64 QFN package. Using an internal sample and hold and low jitter clock buffer, the ADC supports high SNR and high SFDR at high input frequencies. It has coarse and fine gain options that can be used to improve SFDR performance at lower full-scale input ranges.

ADS62P15 includes a digital processing block that consists of several useful and commonly used digital functions such as ADC offset correction, fine gain correction (in steps of 0.05 dB), decimation by 2,4,8 and in-built and custom programmable filters. By default, the digital processing block is bypassed, and its functions are disabled.

Two output interface options exist – parallel CMOS and DDR LVDS (Double Data Rate). ADS62P15 includes internal references while traditional reference pins and associated decoupling capacitors have been eliminated. Nevertheless, the device can also be driven with an external reference. The device is specified over the industrial temperature range (–40°C to 85°C).



Please be aware that an important notice concerning availability, standard warranty, and use in critical applications of Texas Instruments semiconductor products and disclaimers thereto appears at the end of this data sheet.



This integrated circuit can be damaged by ESD. Texas Instruments recommends that all integrated circuits be handled with appropriate precautions. Failure to observe proper handling and installation procedures can cause damage.

ESD damage can range from subtle performance degradation to complete device failure. Precision integrated circuits may be more susceptible to damage because very small parametric changes could cause the device not to meet its published specifications.

FUNCTIONAL BLOCK DIAGRAM

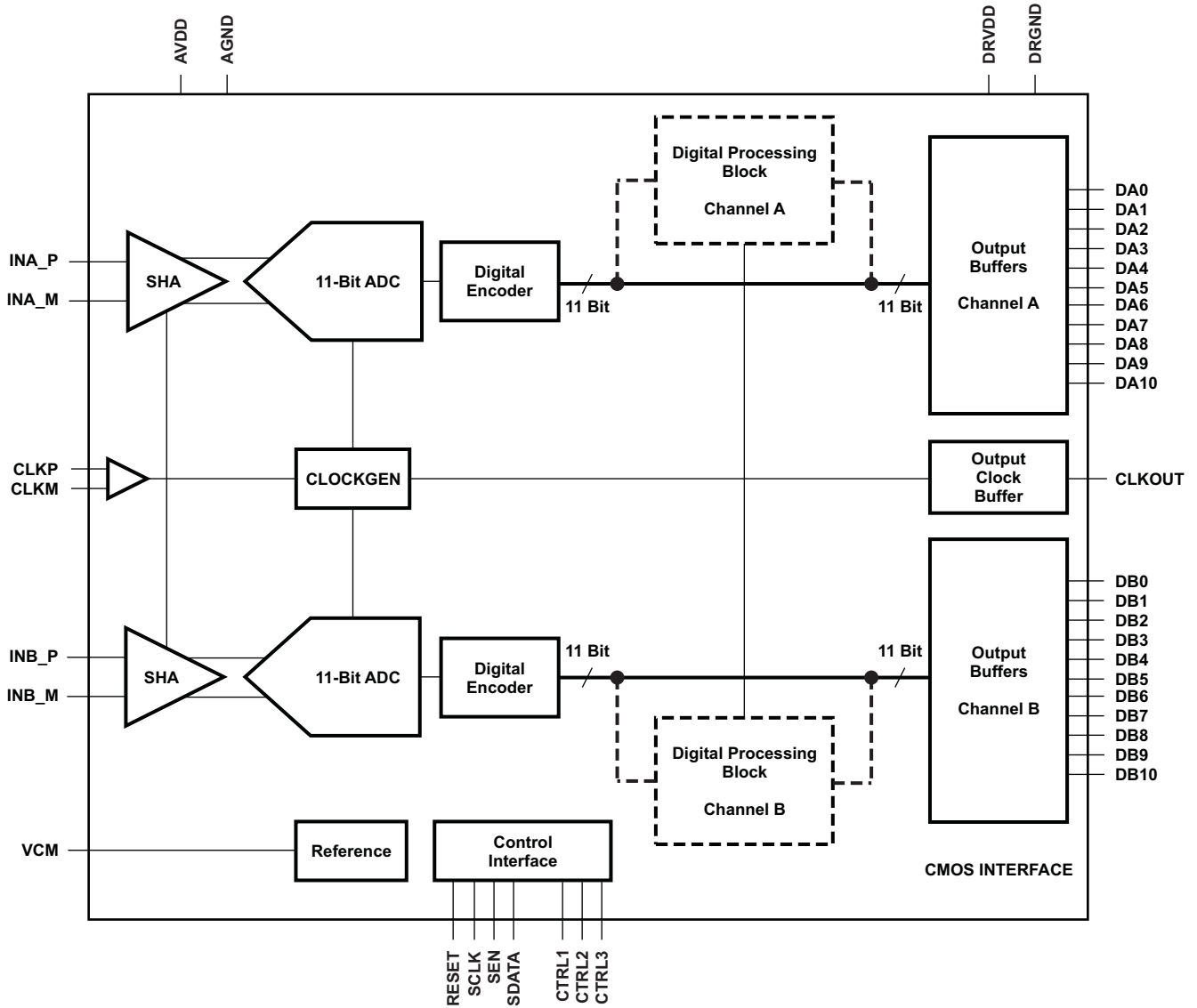

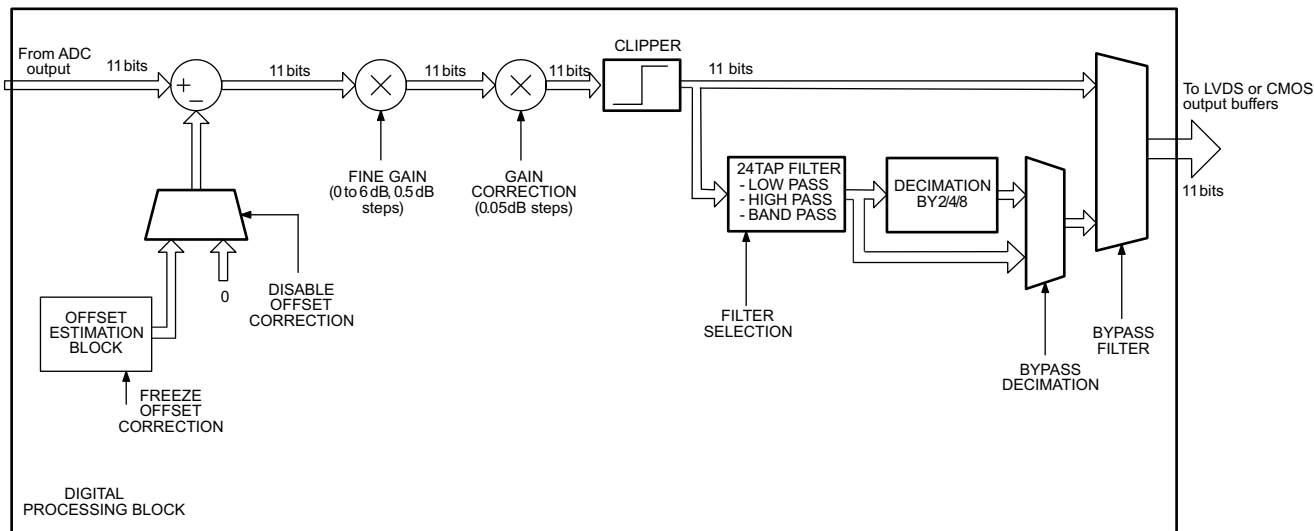

Figure 1. Digital Processing Block Diagram

PACKAGE/ORDERING INFORMATION⁽¹⁾

| PRODUCT | PACKAGE-LEAD | PACKAGE DESIGNATOR | SPECIFIED TEMPERATURE RANGE | LEAD/BALL FINISH | PACKAGE MARKING | ORDERING ⁽²⁾ NUMBER | TRANSPORT MEDIA, QUANTITY |
|----------|--------------|--------------------|-----------------------------|------------------|-----------------|--------------------------------|---------------------------|
| ADS62P15 | QFN-64 | RGC | -40°C to 85°C | Cu NiPdAu | AZ62P15 | ADS62P15RGCT | 250 Tape/Reel |
| | | | | | | ADS62P15RGCRCR | 2000 Tape/Reel |

- (1) For thermal pad size on the package, see the mechanical drawings at the end of this data sheet. $\theta_{JA} = 23.17 \text{ }^\circ\text{C/W}$ (0 LFM airflow), $\theta_{JC} = 22.1 \text{ }^\circ\text{C/W}$ when used with 2 oz. copper trace and pad soldered directly to a JEDEC standard four layer 3 in. x 3 in. PCB.
- (2) For the most current package and ordering information, see the Package Option Addendum at the end of this document, or see the TI website at www.ti.com.

ABSOLUTE MAXIMUM RATINGS⁽¹⁾

| | | VALUE | UNIT |
|-----------|--|--------------------------------------|------|
| V_{SS} | Supply voltage range, AVDD, DRVDD | -0.3 V to 3.9 | V |
| | | -0.3 V to 3.9 | V |
| | Voltage between AGND and DRGND | -0.3 to 0.3 | V |
| | Voltage between AVDD to DRVDD | -0.3 to 3.3 | V |
| | Voltage applied to external pin, CM (in external reference mode) | -0.3 to 2 | V |
| | Voltage applied to analog input pins, INA_P, INA_M, INB_P, INB_M | -0.3V to minimum (3.6, AVDD + 0.3 V) | V |
| | Voltage applied to clock input pins, CLKP, CLKM | -0.3 V to AVDD + 0.3 V | V |
| T_A | Operating free-air temperature range | -40 to 85 | °C |
| T_J | Operating junction temperature range | 125 | °C |
| T_{stg} | Storage temperature range | -65 to 150 | °C |

- (1) Stresses beyond those listed under *absolute maximum ratings* may cause permanent damage to the device. These are stress ratings only and functional operation of the device at these or any other conditions beyond those indicated under *recommended operating conditions* is not implied. Exposure to absolute maximum rated conditions for extended periods may affect device reliability.

RECOMMENDED OPERATING CONDITIONS

over operating free-air temperature range (unless otherwise noted)

| | | MIN | NOM | MAX | UNIT | |
|--|--|---|------|------------|-----------------|---|
| SUPPLIES | | | | | | |
| V _{SS} | Analog supply voltage, AVDD | 3 | 3.3 | 3.6 | V | |
| | Digital supply voltage, DRVDD | CMOS interface | 1.65 | 1.8 to 3.3 | 3.6 | V |
| | | LVDS interface | 3.0 | 3.3 | 3.6 | |
| ANALOG INPUTS | | | | | | |
| Differential input voltage range | | 2 | | | V _{PP} | |
| Input common-mode voltage | | 1.5 ± 0.1 | | | V | |
| Voltage applied on CM in external reference mode | | 1.5 ± 0.05 | | | V | |
| CLOCK INPUT | | | | | | |
| F _s | Input clock sample rate | 1 | | 125 | MSPS | |
| Input clock amplitude differential (V _{CLKP} –V _{CLKM}) | Sine wave, ac-coupled | 0.4 | 3 | | V _{PP} | |
| | LVPECL, ac-coupled | | 1.6 | | | |
| | LVDS, ac-coupled | | 0.7 | | V | |
| | LVC MOS, single-ended, ac-coupled | | 3.3 | | | |
| Input clock duty cycle | | 35% | 50% | 65% | | |
| DIGITAL OUTPUTS | | | | | | |
| Output buffer drive strength ⁽¹⁾ | For C _{LOAD} ≤ 5 pF and DRVDD ≥ 2.2 V | Default strength | | | | |
| | For C _{LOAD} ≥ 5 pF and DRVDD ≥ 2.2 V | Maximum strength | | | | |
| | For DRVDD < 2.2 V | Maximum strength | | | | |
| C _{LOAD} | Maximum external load capacitance from each output pin to DRGND | CMOS interface | | | 5 | |
| | | LVDS interface, without internal termination | | | 5 | |
| | | LVDS interface, with 100 Ω internal termination | | | 10 | |
| R _{LOAD} | Differential load resistance between the LVDS output pairs (LVDS mode) | 100 | | | Ω | |
| T _A | Operating free-air temperature | –40 | | 85 | °C | |

(1) See the [Output buffer strength programmability](#) in application section

ELECTRICAL CHARACTERISTICS

Typical values at 25°C, min and max values are across the full temperature range $T_{MIN} = -40^{\circ}\text{C}$ to $T_{MAX} = 85^{\circ}\text{C}$, $AVDD = 3.3\text{V}$, $DRVDD = 1.8\text{V}$ to 3.3V , sampling frequency = 125 MSPS, 50% clock duty cycle, -1dBFS differential analog input, internal reference mode, applies to CMOS and LVDS interfaces (unless otherwise noted).

| PARAMETER | | TEST CONDITIONS | MIN | TYP | MAX | UNIT |
|--|---|---|------|-----------|-------|----------|
| Resolution | | | | | 11 | bits |
| ANALOG INPUTS | | | | | | |
| | Differential input voltage range | | | 2 | | V_{PP} |
| | Differential input resistance (at dc) | See Figure 33 | | > 1 | | MΩ |
| | Differential input capacitance | See Figure 34 | | 7 | | pF |
| | Analog input bandwidth | | | 450 | | MHz |
| | Analog input common mode current (per input pin) | | | 125 | | μA |
| | VCM common mode voltage output | | | 1.5 | | V |
| | VCM output current capability | | | 4 | | mA |
| POWER SUPPLY | | | | | | |
| I_{SS} | Analog supply current (AVDD) | | | 216 | | mA |
| | Output buffer supply current (DRVDD) CMOS interface | DRVDD=1.8V, 2.5 MHz input signal no load capacitance ⁽¹⁾ | | 17 | | |
| | Total power – CMOS interface | | | 0.74 | | W |
| | Total power – CMOS interface | DRVDD=3.3V, 50MHz input signal 10pF load capacitance | | | 1.225 | W |
| | Total power – LVDS interface | DRVDD = 3.3V | | 0.94 | | W |
| | Global power down | | | 30 | 60 | mW |
| DC ACCURACY | | | | | | |
| | No missing codes | | | Specified | | |
| DNL | Differential Non-Linearity | | -0.8 | ±0.4 | 0.8 | LSB |
| INL | Integral Non-Linearity | | -3.5 | ±1 | 3.5 | LSB |
| E_O | Offset Error | | -10 | ±3 | 10 | mV |
| | Offset error temperature coefficient | | | 0.05 | | mV/°C |
| There are two sources of gain error – internal reference inaccuracy and channel gain error | | | | | | |
| E_{GREF} | Gain error due to internal reference inaccuracy alone | | -1 | ±0.25 | 1 | %FS |
| E_{GCHAN} | Gain error of channel alone ⁽²⁾ | | -1 | ±0.3 | 1 | %FS |
| | Channel gain error temperature coefficient | | | 0.005 | | Δ%/°C |

(1) In CMOS mode, the DRVDD current scales with the sampling frequency and the load capacitance on output pins (see [Figure 30](#)).

(2) This is specified by design and characterization; it is not tested in production.

ELECTRICAL CHARACTERISTICS (continued)

Typical values at 25°C, min and max values are across the full temperature range $T_{MIN} = -40^{\circ}C$ to $T_{MAX} = 85^{\circ}C$, $AVDD = 3.3V$, $DRVDD = 1.8V$ to $3.3V$, sampling frequency = 125 MSPS, 50% clock duty cycle, -1dBFS differential analog input, internal reference mode, applies to CMOS and LVDS interfaces (unless otherwise noted).

| PARAMETER | | TEST CONDITIONS | | MIN | TYP | MAX | UNIT |
|-----------|--------------------------------------|-----------------|-------------|------|------|-----|------|
| SNR | Signal to noise ratio | Fin = 10 MHz | | | 67.2 | | dBFS |
| | | Fin = 50 MHz | | 65.5 | 67.1 | | |
| | | Fin = 70 MHz | | | 67.1 | | |
| | | Fin = 170 MHz | 0 dB gain | | 66.8 | | |
| | | | 3.5 dB gain | | 66.4 | | |
| | | Fin = 230 MHz | 0 dB gain | | 66.6 | | |
| | | | 3.5 dB gain | | 66.2 | | |
| SINAD | Signal to noise and distortion ratio | Fin = 10 MHz | | | 67.1 | | dBFS |
| | | Fin = 50 MHz | | 65 | 66.9 | | |
| | | Fin = 70 MHz | | | 66.9 | | |
| | | Fin = 170 MHz | 0 dB gain | | 66.5 | | |
| | | | 3.5 dB gain | | 66.2 | | |
| | | Fin = 230 MHz | 0 dB gain | | 66.3 | | |
| | | | 3.5 dB gain | | 65.9 | | |
| ENOB | Effective number of bits | Fin = 50 MHz | | 10.5 | 10.8 | | LSB |
| SFDR | Spurious free dynamic range | Fin = 10 MHz | | | 89 | | dBc |
| | | Fin = 50 MHz | | 75 | 79 | | |
| | | Fin = 70 MHz | | | 85 | | |
| | | Fin = 170 MHz | 0 dB gain | | 82 | | |
| | | | 3.5 dB gain | | 84 | | |
| | | Fin = 230 MHz | 0 dB gain | | 78 | | |
| | | | 3.5 dB gain | | 80 | | |
| THD | Total harmonic distortion | Fin = 10 MHz | | | 87 | | dBc |
| | | Fin = 50 MHz | | 72 | 77 | | |
| | | Fin = 70 MHz | | | 83 | | |
| | | Fin = 170 MHz | 0 dB gain | | 79 | | |
| | | | 3.5 dB gain | | 81 | | |
| | | Fin = 230 MHz | 0 dB gain | | 75 | | |
| | | | 3.5 dB gain | | 77 | | |
| HD2 | Second harmonic distortion | Fin = 10 MHz | | | 95 | | dBc |
| | | Fin = 50 MHz | | 75 | 93 | | |
| | | Fin = 70 MHz | | | 93 | | |
| | | Fin = 170 MHz | 0 dB gain | | 85 | | |
| | | | 3.5 dB gain | | 87 | | |
| | | Fin = 230 MHz | 0 dB gain | | 82 | | |
| | | | 3.5 dB gain | | 84 | | |
| HD3 | Third harmonic distortion | Fin = 10 MHz | | | 89 | | dBc |
| | | Fin = 50 MHz | | 75 | 79 | | |
| | | Fin = 70 MHz | | | 85 | | |
| | | Fin = 170 MHz | 0 dB gain | | 82 | | |
| | | | 3.5 dB gain | | 84 | | |
| | | Fin = 230 MHz | 0 dB gain | | 78 | | |
| | | | 3.5 dB gain | | 80 | | |

ELECTRICAL CHARACTERISTICS (continued)

Typical values at 25°C, min and max values are across the full temperature range $T_{MIN} = -40^{\circ}C$ to $T_{MAX} = 85^{\circ}C$, AVDD = 3.3V, DRVDD = 1.8V to 3.3V, sampling frequency = 125 MSPS, 50% clock duty cycle, -1dBFS differential analog input, internal reference mode, applies to CMOS and LVDS interfaces (unless otherwise noted).

| PARAMETER | | TEST CONDITIONS | MIN | TYP | MAX | UNIT |
|------------|------------------------------------|---|-----|-----|-----|--------------|
| Worst Spur | Other than second, third harmonics | Fin = 10 MHz | | 94 | | dBc |
| | | Fin = 50 MHz | | 92 | | |
| | | Fin = 70 MHz | | 94 | | |
| | | Fin = 170 MHz | | 90 | | |
| | | Fin = 230 MHz | | 88 | | |
| IMD | 2-Tone intermodulation distortion | F1 = 185 MHz, F2 = 190 MHz each tone at -7 dBFS | | 88 | | dBFS |
| | Input overload recovery | Recovery to within 1% (of final value) for 6-dB overload with sine wave input | | 1 | | clock cycles |
| | Cross-talk | Cross-talk signal frequency upto 100 MHz | | 95 | | dB |
| PSRR | AC Power supply rejection ratio | For 100 mV pp signal on AVDD supply, frequency upto 10 MHz | | 45 | | dBc |

DIGITAL CHARACTERISTICS

The DC specifications refer to the condition where the digital outputs are not switching, but are permanently at a valid logic level 0 or 1. AVDD=3.3V, DRVDD=1.8V to 3.3V, unless otherwise specified.

| PARAMETER | TEST CONDITIONS | MIN | TYP | MAX | UNIT |
|--|-----------------------------|--|-------|------|------|
| DIGITAL INPUTS | | | | | |
| High-level input voltage | | 2.4 | | | V |
| Low-level input voltage | | | | 0.8 | V |
| High-level input current | | | 33 | | μA |
| Low-level input current | | | -33 | | μA |
| Input capacitance | | | 4 | | Pf |
| DIGITAL OUTPUTS – CMOS MODE, DRVDD = 1.8 to 3.3V | | | | | |
| High-level output voltage | | | DRVDD | | V |
| Low-level output voltage | | | 0 | | V |
| Output capacitance (internal to device) | | | 2 | | pF |
| DIGITAL OUTPUTS – LVDS MODE^{(1) (2)}, DRVDD = 3.3V | | | | | |
| High-level output voltage | | | 1375 | | mV |
| Low-level output voltage | | | 1025 | | mV |
| V _{OD} | Output differential voltage | 250 | 350 | 500 | mV |
| V _{OS} | Output offset voltage | Common-mode voltage of OUTP and OUTM | | 1200 | mV |
| | Output Capacitance | Output capacitance inside the device, from either output to ground | | 2 | pF |

(1) LVDS buffer current setting, I_O = 3.5 mA.

(2) External differential load resistance between the LVDS output pairs, R_{LOAD} = 100 Ω.

TIMING REQUIREMENTS – LVDS AND CMOS MODES⁽¹⁾

Typical values are at 25°C, min and max values are across the full temperature range $T_{MIN} = -40^{\circ}C$ to $T_{MAX} = 85^{\circ}C$, $AVDD = 3.3V$, $DRVDD = 1.8V$ to $3.3V$, sampling frequency = 125MSPS, sine wave input clock, $3V_{PP}$ clock amplitude, $C_{LOAD} = 5pF$ ⁽²⁾, $I_O = 3.5mA$, $R_{LOAD} = 100\Omega$ ⁽³⁾, no internal termination, unless otherwise noted.

| PARAMETER | | TEST CONDITIONS | MIN | TYP | MAX | UNIT | |
|---|-----------------------------------|---|------|-----|-----|--------------|----|
| t_a | Aperture delay | | 0.8 | 1.8 | 2.8 | ns | |
| | Aperture delay matching | $ t_{a1} - t_{a2} $, Channel-to-channel within the same device | 50 | | | ps | |
| | | $ t_{a1} - t_{a2} $, Channel-to-channel across two devices at same temperature | 450 | | | | |
| t_j | Aperture jitter | | 130 | | | fs rms | |
| | Wake-up time to valid output data | from global power down | 15 | 50 | | μs | |
| | | from channel standby | 100 | 200 | | ns | |
| | | from output buffer disable | CMOS | 100 | 200 | | ns |
| | | | LVDS | 200 | 500 | | ns |
| | Latency | default, after reset | 14 | | | clock cycles | |
| | | in low latency mode | 10 | | | clock cycles | |
| | | with decimation filter enabled | 15 | | | clock cycles | |
| DDR LVDS MODE⁽⁴⁾ DRVDD = 3.3V | | | | | | | |
| t_{su} | Data setup time ⁽⁵⁾ | Data valid ⁽⁶⁾ to zero-crossing of CLKOUTP | 0.6 | 1.5 | | ns | |
| t_h | Data hold time ⁽⁵⁾ | Zero-crossing of CLKOUTP to data becoming invalid ⁽⁶⁾ | 1.0 | 2.3 | | ns | |
| t_{PDI} | Clock propagation delay | Input clock rising edge cross-over to output clock rising edge cross-over $20\text{ MSPS} \leq \text{Sampling frequency} \leq 125\text{ MSPS}$ | 3.5 | 5.5 | 7.5 | ns | |
| | LVDS bit clock duty cycle | Duty cycle of differential clock, (CLKOUTP-CLKOUTM) $10\text{ MSPS} \leq \text{Sampling frequency} \leq 125\text{ MSPS}$ | 46% | 49% | 52% | | |
| t_{RISE} | Data rise time | Rise time measured from -100 mV to $+100\text{ mV}$ $1\text{ MSPS} \leq \text{Sampling frequency} \leq 125\text{ MSPS}$ | 70 | 110 | 170 | ps | |
| t_{FALL} | Data fall time | Fall time measured from $+100\text{ mV}$ to -100 mV $1\text{ MSPS} \leq \text{Sampling frequency} \leq 125\text{ MSPS}$ | 70 | 110 | 170 | ps | |
| $t_{CLKRISE}$ | Output clock rise time | Rise time measured from -100 mV to $+100\text{ mV}$ $1\text{ MSPS} \leq \text{Sampling frequency} \leq 125\text{ MSPS}$ | 70 | 110 | 170 | ps | |
| $t_{CLKFALL}$ | Output clock fall time | Fall time measured from $+100\text{ mV}$ to -100 mV $1\text{ MSPS} \leq \text{Sampling frequency} \leq 125\text{ MSPS}$ | 70 | 110 | 170 | ps | |
| PARALLEL CMOS MODE DRVDD = 2.5V to 3.3V | | | | | | | |
| t_{su} | Data setup time ⁽⁵⁾ | Data valid ⁽⁷⁾ to 50% of CLKOUT rising edge | 2.0 | 3.5 | | ns | |
| t_h | Data hold time ⁽⁵⁾ | 50% of CLKOUT rising edge to data becoming invalid ⁽⁷⁾ | 2.0 | 3.5 | | ns | |
| t_{PDI} | Clock propagation delay | 50% of input clock rising edge to 50% of CLKOUT rising edge $20\text{ MSPS} \leq \text{Sampling frequency} \leq 125\text{ MSPS}$ | 5.8 | 7.3 | 8.8 | ns | |
| | Output clock duty cycle | Duty cycle of output clock, CLKOUT $10\text{ MSPS} \leq \text{Sampling frequency} \leq 125\text{ MSPS}$ | 45% | 53% | 60% | | |
| t_{RISE} | Data rise time | Rise time measured from 20% to 80% of DRVDD $1\text{ MSPS} \leq \text{Sampling frequency} \leq 125\text{ MSPS}$ | 0.7 | 1.5 | 2.5 | ns | |
| t_{FALL} | Data fall time | Fall time measured from 80% to 20% of DRVDD $1\text{ MSPS} \leq \text{Sampling frequency} \leq 125\text{ MSPS}$ | 0.7 | 1.5 | 2.5 | ns | |
| $t_{CLKRISE}$ | Output clock rise time | Rise time measured from 20% to 80% of DRVDD $1\text{ MSPS} \leq \text{Sampling frequency} \leq 125\text{ MSPS}$ | 0.7 | 1.5 | 2.5 | ns | |

(1) Timing parameters are ensured by design and characterization and not tested in production.

(2) C_{LOAD} is the effective external single-ended load capacitance between each output pin and ground

(3) I_O refers to the LVDS buffer current setting; R_{LOAD} is the differential load resistance between the LVDS output pair.

(4) Measurements are done with a transmission line of 100 Ω characteristic impedance between the device and the load.

(5) Setup and hold time specifications take into account the effect of jitter on the output data and clock.

(6) Data valid refers to LOGIC HIGH of +100.0 mV and LOGIC LOW of -100.0 mV .

(7) Data valid refers to LOGIC HIGH of 2V (1.7V) and LOGIC LOW of 0.8V (0.7V) for DRVDD = 3.3V (2.5V)

TIMING REQUIREMENTS – LVDS AND CMOS MODES⁽¹⁾ (continued)

Typical values are at 25°C, min and max values are across the full temperature range T_{MIN} = -40°C to T_{MAX} = 85°C, AVDD = 3.3V, DRVDD = 1.8V to 3.3V, sampling frequency = 125MSPS, sine wave input clock, 3V_{PP} clock amplitude, C_{LOAD} = 5pF⁽²⁾, I_O = 3.5mA, R_{LOAD} = 100Ω⁽³⁾, no internal termination, unless otherwise noted.

| PARAMETER | | TEST CONDITIONS | MIN | TYP | MAX | UNIT |
|---|------------------------|--|------|------|------|------|
| t _{CLKFALL} | Output clock fall time | Fall time measured from 80% to 20% of DRVDD 1 MSPS ≤ Sampling frequency ≤ 125 MSPS | 0.7 | 1.5 | 2.5 | ns |
| PARALLEL CMOS INTERFACE, DRVDD = 1.8V, maximum buffer drive strength⁽⁸⁾ | | | | | | |
| t _{START} | Start time | Input clock rising edge to data getting valid, ⁽⁹⁾ ⁽¹⁰⁾ | | | 8.5 | ns |
| t _{DV} | | Width of valid data window | 3.3 | 6.0 | | ns |
| PARALLEL CMOS INTERFACE, DRVDD = 1.8V, MULTIPLEXED MODE, FS = 65 MSPS, maximum buffer drive strength | | | | | | |
| t _{START_CHA} | Start time, channel A | Input clock falling edge to channel A data getting valid, ⁽⁹⁾ ⁽¹⁰⁾ | | 0.8 | 2.3 | ns |
| t _{DV_CHA} | Data valid, channel A | Width of valid data window | 5.4 | 6.4 | | ns |
| t _{START_CHB} | Start time, channel B | Input clock rising edge to channel B data getting valid | | 1.1 | 2.4 | ns |
| t _{DV_CHB} | Data valid, channel B | Width of valid data window | 5 | 6 | | ns |
| PARALLEL CMOS INTERFACE, DRVDD = 1.8V, MULTIPLEXED MODE, FS = 40 MSPS, maximum buffer drive strength | | | | | | |
| t _{START_CHA} | Start time, channel A | Input clock falling edge to channel A data getting valid, ⁽⁹⁾ ⁽¹⁰⁾ | | -4.5 | -3 | ns |
| t _{DV_CHA} | Data valid, channel A | Width of valid data window | 10.3 | 11.3 | | ns |
| t _{START_CHB} | Start time, channel B | Input clock rising edge to channel B data getting valid | | -4.1 | -2.5 | ns |
| t _{DV_CHB} | Data valid, channel B | Width of valid data window | 9.7 | 10.7 | | ns |

- (8) For DRVDD < 2.2V, output clock cannot be used for data capture. A delayed version of the input clock can be used, that gives the desired setup & hold times at the receiving chip
- (9) Data valid refers to LOGIC HIGH of 1.26V and LOGIC LOW of 0.54V for DRVDD = 1.8V.
- (10) Measured from zero-crossing of input clock having 50% duty cycle.

Table 2. Timing Characteristics at Lower Sampling Frequencies

| Sampling Frequency, MSPS | t _{su} DATA SETUP TIME, ns | | | t _h DATA HOLD TIME, ns | | |
|--|-------------------------------------|------|-----|-----------------------------------|------|-----|
| | MIN | TYP | MAX | MIN | TYP | MAX |
| CMOS INTERFACE, DRVDD = 2.5 TO 3.3V | | | | | | |
| 105 | 2.8 | 4.3 | | 2.7 | 4.2 | |
| 80 | 4.3 | 5.8 | | 4.2 | 5.7 | |
| 65 | 5.7 | 7.2 | | 5.6 | 7.1 | |
| 40 | 10.5 | 12 | | 10.3 | 11.8 | |
| 20 | 23 | 24.5 | | 23 | 24.5 | |
| DDR LVDS INTERFACE, DRVDD = 3.3V | | | | | | |
| 105 | 1 | 2.3 | | 1.0 | 2.3 | |
| 80 | 2.4 | 3.8 | | | | |
| 65 | 3.8 | 5.2 | | | | |
| 40 | 8.5 | 10 | | | | |
| 20 | 21 | 22.5 | | | | |

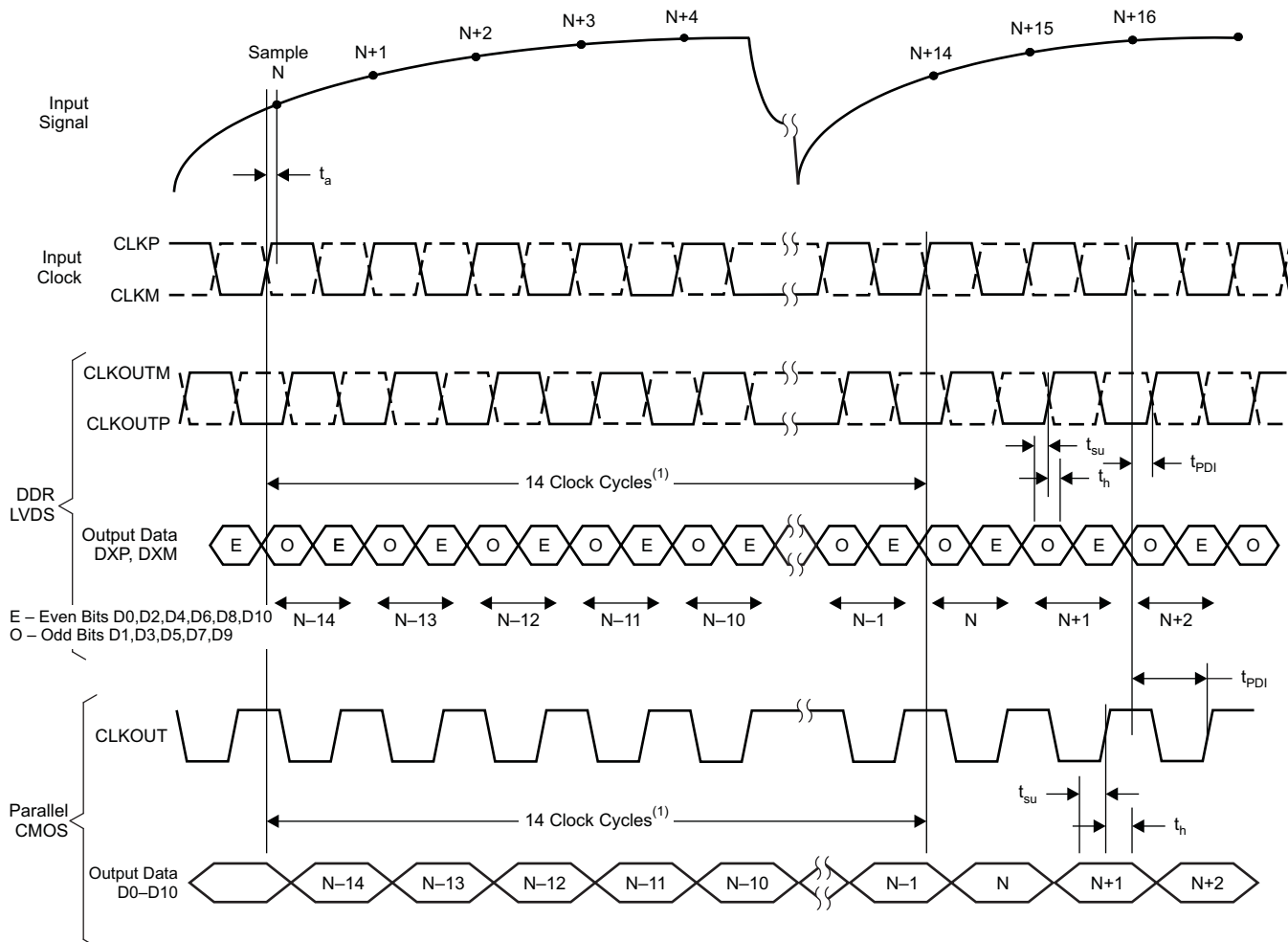

T0105-05

(1) Latency is 10 clock cycles in low-latency mode

Figure 2. Latency Diagram

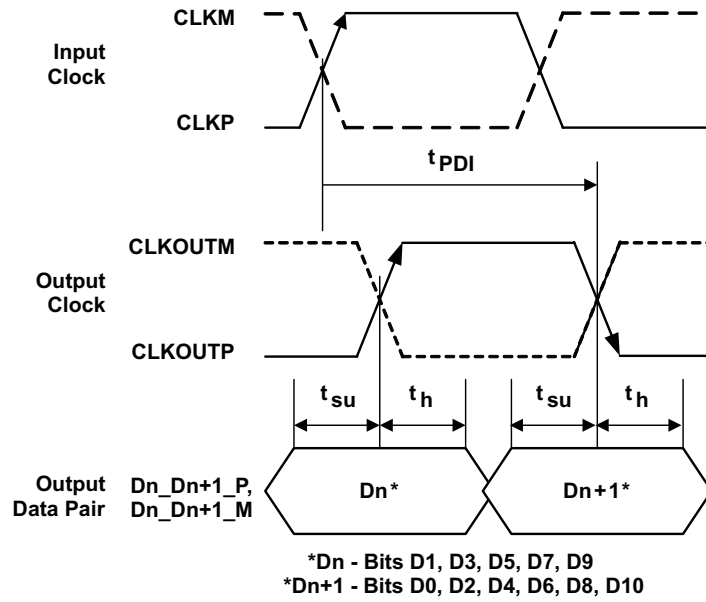
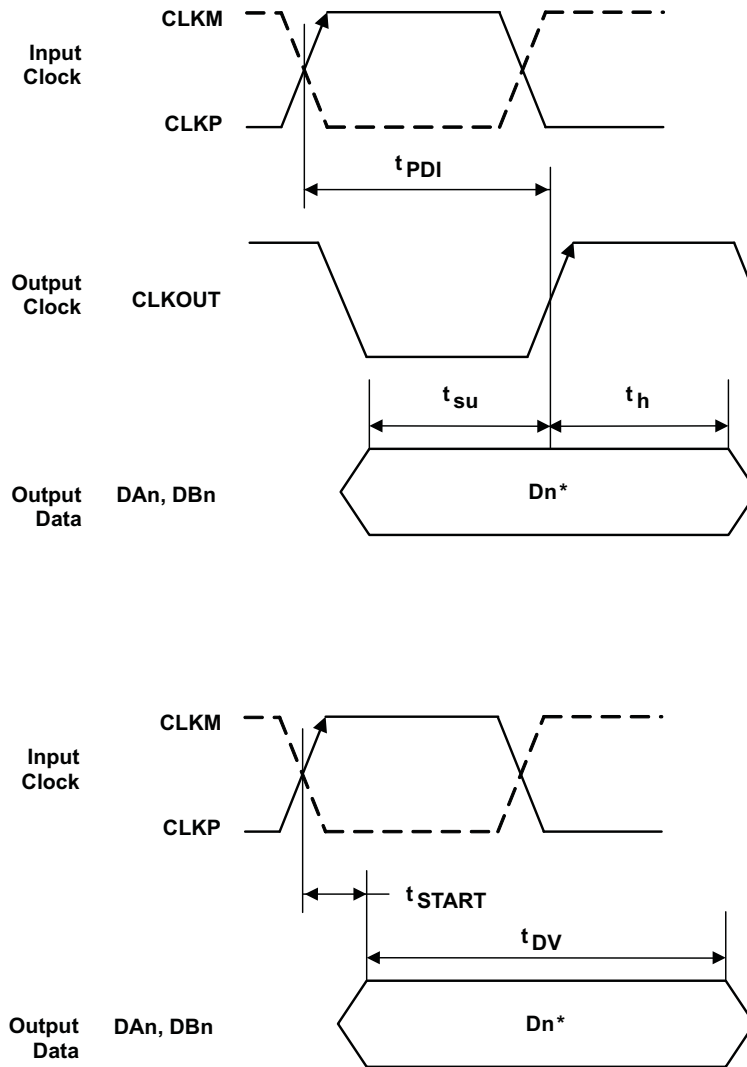
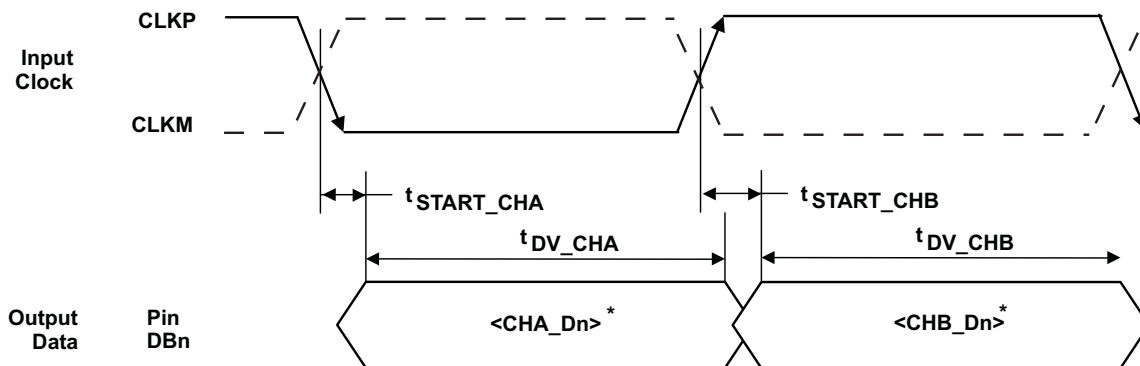

Figure 3. LVDS Mode Timing



*Dn - Bits D0, D1, D2, . . . of Channels A & B

Figure 4. CMOS Mode Timing



*Dn - Bits D0, D1, D2, . . .

Figure 5. Multiplexed Mode Timing (CMOS only)

DEVICE CONFIGURATION

ADS62P15 can be configured independently using either parallel interface control or serial interface programming.

USING PARALLEL INTERFACE CONTROL ONLY

To control the device using the parallel interface, keep RESET tied to **high** (AVDD). Pins SEN, SCLK, CTRL1, CTRL2 and CTRL3 can be used to directly control certain modes of the ADC. After power-up, the device will automatically get configured as per the parallel pin voltage settings (Table 4 to Table 6).

In this mode, SEN and SCLK function as parallel *analog* control pins, which can be configured using a simple resistor divider (Figure 6, using resistors $\leq 10\%$ tolerance). Table 3 has a brief description of the modes controlled by the parallel pins. SDATA has no parallel function and can be kept low.

Table 3. Parallel Pin Definition

| PIN | TYPE OF PIN | CONTROLS MODES |
|-------|---|---|
| SCLK | Analog control pins (controlled by analog voltage levels, see) | Coarse Gain and Internal/External reference |
| SEN | | LVDS/CMOS interface and Output Data Format |
| CTRL1 | Digital control pins (controlled by digital logic levels) | Together control various power down modes and MUX mode. |
| CTRL2 | | |
| CTRL3 | | |

USING SERIAL INTERFACE PROGRAMMING ONLY

To program the device using the serial interface, keep RESET low. Pins SEN, SDATA, and SCLK function as serial interface *digital* pins and are used to access the internal registers of ADC. The registers must first be reset to their default values either by applying a pulse on RESET pin or by setting bit <RST> = 1. After reset, the RESET pin must be kept low.

The serial interface section describes the register programming and register reset in more detail. Since the parallel pins (CTRL1, CTRL2, CTRL3) are not used in this mode, they must be tied to ground.

USING BOTH SERIAL INTERFACE and PARALLEL CONTROLS

For increased flexibility, a combination of serial interface registers and parallel pin controls (CTRL1 to CTRL3) can also be used to configure the device. To allow this, keep RESET **low**.

The parallel interface control pins CTRL1 to CTRL3 are available. After power-up, the device will automatically get configured as per the voltage settings on these pins (Table 6).

SEN, SDATA, and SCLK function as serial interface *digital* pins and are used to access the internal registers of ADC. The registers must first be reset to their default values either by applying a pulse on RESET pin or by setting bit <RST> = 1. After reset, the RESET pin must be kept low. The serial interface section describes the register programming and register reset in more detail.

Since the power down modes can be controlled using both the parallel pins and serial registers, the priority between the two is determined by <OVRD> bit. When <OVRD> bit = 0, pins CTRL1 to CTRL3 control the power down modes. With <OVRD> = 1, register bits <POWER DOWN> control these modes, over-riding the pin settings.

DETAILS OF PARALLEL CONFIGURATION ONLY

The functions controlled by each parallel pin are described below. A simple way of configuring the parallel pins is shown in [Figure 6](#).

Table 4. SCLK (Analog Control Pin)

| VOLTAGE APPLIED ON SCLK | DESCRIPTION |
|-------------------------|--|
| 0 +200mV/-0mV | 0dB gain and Internal reference |
| (3/8)AVDD +/- 200mV | 0dB gain and External reference |
| (5/8)2AVDD +/- 200mV | 3.5dB Coarse gain and External reference |
| AVDD +0mV/-200mV | 3.5dB Coarse gain and Internal reference |

Table 5. SEN (Analog Control Pin)

| VOLTAGE APPLIED ON SEN | DESCRIPTION |
|------------------------|---|
| 0 +200mV/-0mV | 2s complement format and DDR LVDS output |
| (3/8)AVDD +/- 200mV | Straight binary and DDR LVDS output |
| (5/8)AVDD +/- 200mV | Straight binary and parallel CMOS output |
| AVDD +0mV/-200mV | 2s complement format and parallel CMOS output |

Table 6. CTRL1, CTRL2 and CTRL3 (Digital Control Pins)

| CTRL1 | CTRL2 | CTRL3 | DESCRIPTION |
|-------|-------|-------|--|
| LOW | LOW | LOW | Normal operation |
| LOW | LOW | HIGH | Channel A output buffer disabled |
| LOW | HIGH | LOW | Channel B output buffer disabled |
| LOW | HIGH | HIGH | Channel A and B output buffer disabled |
| HIGH | LOW | LOW | Power down global |
| HIGH | LOW | HIGH | Channel A standby |
| HIGH | HIGH | LOW | Channel B standby |
| HIGH | HIGH | HIGH | MUX mode of operation, channel A and B data is multiplexed and output on DB10 to DB0 pins. See Multiplexed output mode for detailed description. |

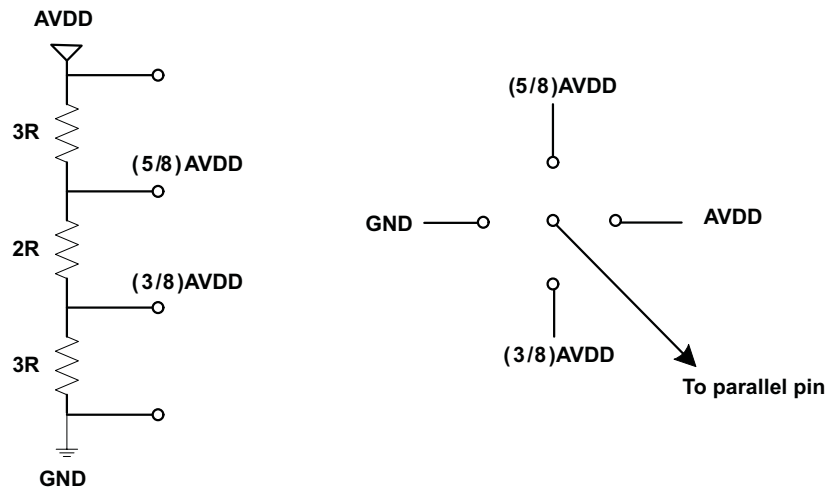

Figure 6. Simple Scheme to Configure Parallel Pins

SERIAL INTERFACE

The ADC has a set of internal registers, which can be accessed by the serial interface formed by pins SEN (Serial interface Enable), SCLK (Serial Interface Clock) and SDATA (Serial Interface Data).

Serial shift of bits into the device is enabled when SEN is low. Serial data SDATA is latched at every falling edge of SCLK when SEN is active (low). The serial data is loaded into the register at every 16th SCLK falling edge when SEN is low. In case the word length exceeds a multiple of 16 bits, the excess bits are ignored. Data can be loaded in multiple of 16-bit words within a single active SEN pulse.

The first 8 bits form the register address and the remaining 8 bits the register data. The interface can work with SCLK frequency from 20 MHz down to low speeds (few Hertz), and also with a non-50% SCLK duty cycle.

Register Initialization

After power-up, the internal registers *must* be initialized to their default values. This can be done in one of two ways:

1. Either through hardware reset by applying a high-going pulse on RESET pin (of width greater than 10ns) as shown in Figure 7.

OR

2. By applying software reset. Using the serial interface, set the <RST> bit to *high*. This initializes internal registers to their default values and then self-resets the <RST> bit to *low*. In this case the RESET pin is kept *low*.

SERIAL INTERFACE TIMING CHARACTERISTICS

Typical values at 25°C, min and max values across the full temperature range T_{MIN} = -40°C to T_{MAX} = 85°C, AVDD = 3.3V, DRVDD = 1.8V to 3.3V, unless otherwise noted.

| PARAMETER | | MIN | TYP | MAX | UNIT |
|---------------------|------------------------|------|-----|-----|------|
| f _{SCLK} | SCLK frequency | > DC | | 20 | MHz |
| t _{SLOADS} | SEN to SCLK setup time | 25 | | | ns |
| t _{SLOADH} | SCLK to SEN hold time | 25 | | | ns |
| t _{DS} | SDATA setup time | 25 | | | ns |
| t _{DH} | SDATA hold time | 25 | | | ns |

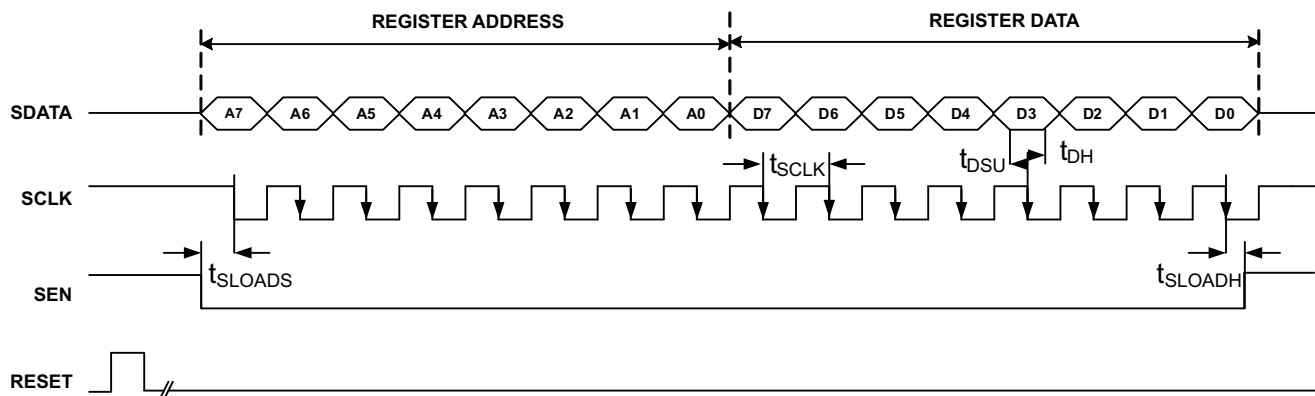

Figure 7. Serial Interface Timing

Serial Register Readout (only when CMOS interface is used)

The device includes an option where the contents of the internal registers can be read back. This may be useful as a diagnostic check to verify the serial interface communication between the external controller and the ADC.

1. First, set register bit <SERIAL READOUT> = 1. This also disables any further writes into the registers.
2. Initiate a serial interface cycle specifying the address of the register (A7-A0) whose content has to be read.
3. The device outputs the contents (D7-D0) of the selected register on the SDOUT pin.
4. The external controller can latch the contents at the falling edge of SCLK.
5. To enable register writes, reset register bit <SERIAL READOUT> = 0.

The serial register readout works only with CMOS interface; with LVDS interface, pin 56 functions as CLKOUTM. When <SERIAL READOUT> is disabled, SDOUT pin is forced low or high by the device (and not put in high-impedance). If serial readout is not used, SDOUT pin must be floated.

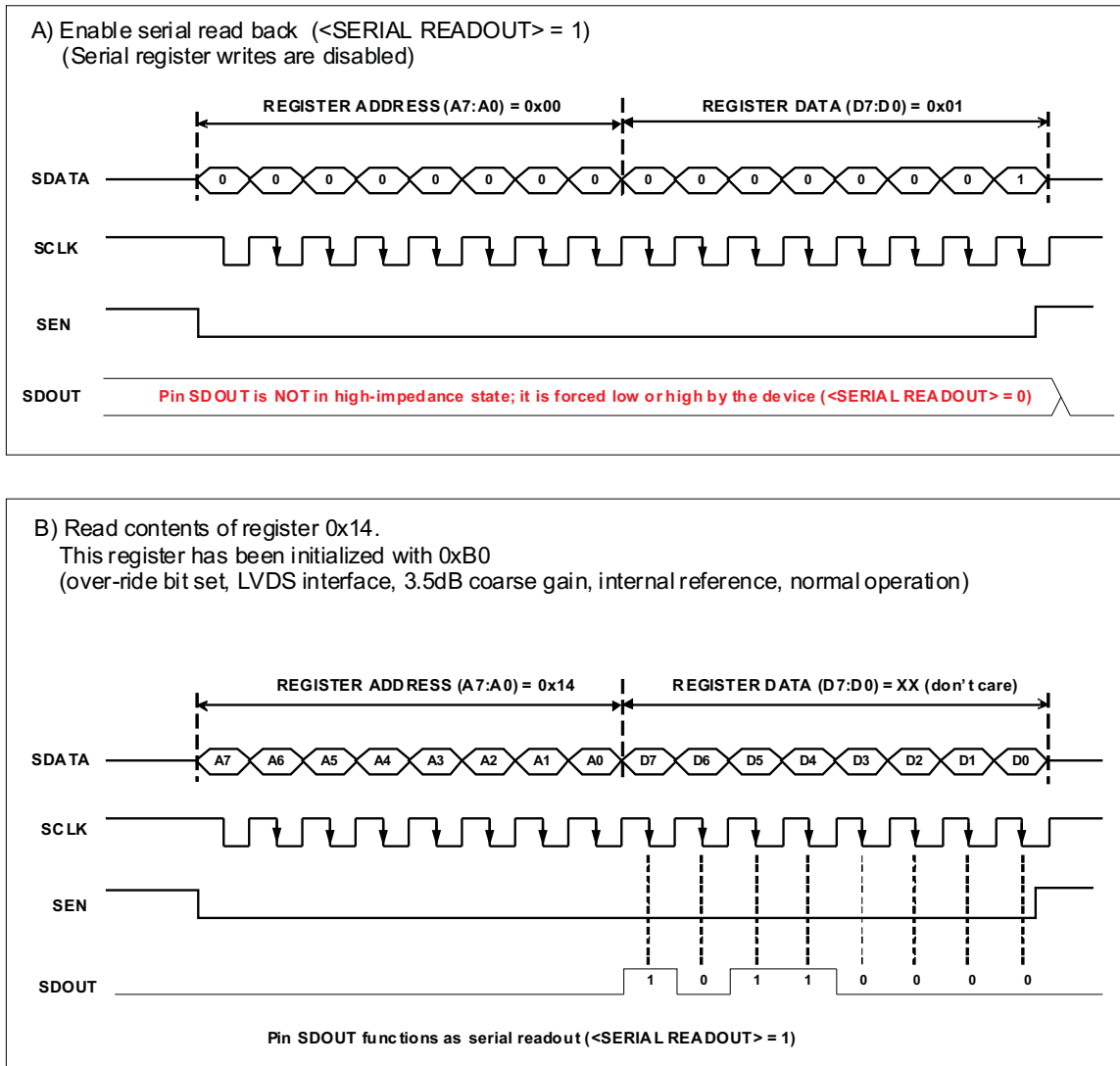
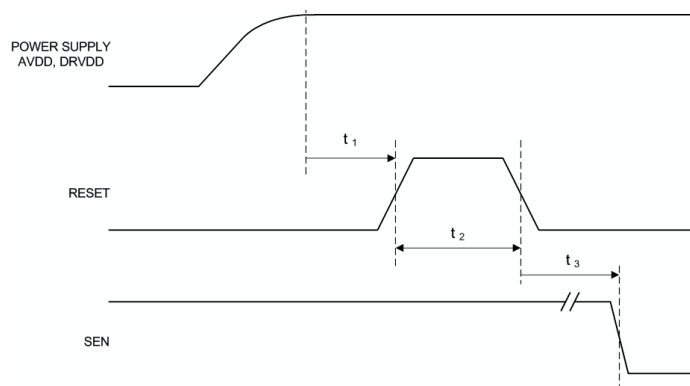

Figure 8. Serial Readout

RESET TIMING

Typical values at 25°C, min and max values across the full temperature range $T_{MIN} = -40^{\circ}C$ to $T_{MAX} = 85^{\circ}C$, unless otherwise noted.

| PARAMETER | CONDITIONS | MIN | TYP | MAX | UNIT |
|-----------|----------------------|-----|-----|-----|------|
| t_1 | Power-on delay | 5 | | | ms |
| t_2 | Reset pulse width | 10 | | | ns |
| t_3 | Register write delay | 25 | | | ns |
| t_{PO} | Power-up time | | 7 | | ms |



NOTE: : A high-going pulse on RESET pin is required in serial interface mode in case of initialization through hardware reset. For parallel interface operation, RESET has to be tied permanently HIGH.

Figure 9. Reset Timing Diagram

SERIAL REGISTER MAP

Table 7. Summary of Functions Supported by Serial Interface ⁽¹⁾

| REGISTER ADDRESS | REGISTER FUNCTIONS | | | | | | | |
|------------------|--|---|---|---|--|---|--------------------------------|------------------|
| A7–A0 IN HEX | D7 | D6 | D5 | D4 | D3 | D2 | D1 | D0 |
| 00 | 0 | 0 | 0 | 0 | 0 | 0 | <RST> Software Reset | <SERIAL READOUT> |
| 10 | <CLKOUT STRENGTH> | | 0 | 0 | 0 | 0 | 0 | 0 |
| 11 | 0 | 0 | <CURRENT DOUBLE> LVDS <i>buffer current double</i> | | <LVDS CURRENT> LVDS <i>buffer current programmability</i> | | <DATAOUT STRENGTH> | |
| 12 | 0 | 0 | <LVDS TERMINATION> <i>Internal termination programmability</i> | | | | | |
| 13 | 0 | 0 | 0 | <OFFSET FREEZE> | 0 | 0 | 0 | 0 |
| 14 | <OVRD> <i>Over-ride bit</i> | 0 | <OUTPUT INTERFACE> LVDS or CMOS <i>interface</i> | <COARSE GAIN> 3.5 dB gain | <REF> <i>Internal/External reference</i> | <POWER DOWN MODES> and MUX mode | | |
| 16 | 0 | 0 | 0 | <DATA FORMAT> 2s complement or straight binary | Bit/Byte wise (LVDS only) | <TEST PATTERNS> | | |
| 17 | 0 | 0 | 0 | 0 | <FINE GAIN> <i>0 to 6 dB gain in 0.5 dB steps</i> | | | |
| 18 | <CUSTOM LOW> <i>Lower 5bits</i> | | | | | 0 | 0 | 0 |
| 19 | 0 | 0 | <CUSTOM HIGH> <i>Upper 6 bits</i> | | | | | |
| 1A | <LOW LATENCY> | <OFFSET TC> <i>Offset correction time constant</i> | | | <GAIN CORRECTION> <i>0 to 0.5 dB, steps of 0.05 dB</i> | | | |
| 1B | <OFFSET EN> <i>Other correction enable</i> | 0 | <FILTER COEFF SELECT> <i>In-built or custom coefficients</i> | <DECIMATION Enable> <i>Enable decimation</i> | <ODD TAP Enable> | <DECIMATION RATE> <i>Decimate by 2, 4, 8</i> | | |
| 1D | 0 | 0 | 0 | 0 | 0 | 0 | <DECIMATION FILTER FREQ BANDS> | |
| 1E to 2F | <FILTER COEFFICIENTS> <i>12 coefficients, each 12 bit signed</i> | | | | | | | |

(1) Multiple functions in a register can be programmed in a single write operation.

DESCRIPTION OF SERIAL REGISTERS
Table 8.

| A7–A0 (hex) | D7 | D6 | D5 | D4 | D3 | D2 | D1 | D0 |
|----------------|----|----|----|----|----|----|-------------------------|---------------------|
| 00 | 0 | 0 | 0 | 0 | 0 | 0 | <RST> Software Reset | <SERIAL READOUT> |

D1 <RST>

1 Software reset applied – resets all internal registers and self-clears to 0.

D0 <SERIAL READOUT>

1 Serial readout disabled. SDOOUT pin is forced low or high by the device (and not put in high-impedance state)

0 Serial readout enabled, SDOOUT functions as serial data readout pin.

Table 9.

| A7–A0 (hex) | D7 | D6 | D5 | D4 | D3 | D2 | D1 | D0 |
|----------------|-------------------|----|----|----|----|----|----|----|
| 10 | <CLKOUT STRENGTH> | | 0 | 0 | 0 | 0 | 0 | 0 |

D7–D6 <CLKOUT STRENGTH> **Output clock buffer drive strength control**

01 WEAKER than default drive

00 DEFAULT drive strength

11 STRONGER than default drive strength (recommended for load capacitances > 5 pF)

10 MAXIMUM drive strength (recommended for load capacitances > 5 pF)

Table 10.

| A7–A0 (hex) | D7 | D6 | D5 | D4 | D3 | D2 | D1 | D0 |
|----------------|----|----|--|----|---|----|-------------------|----|
| 11 | 0 | 0 | <CURRENT DOUBLE> LVDS buffer current double | | LVDS CURRENT> LVDS buffer current programmability | | DATAOUT STRENGTH> | |

D1–D0 <DATAOUT STRENGTH> **Output data buffer drive strength control**

01 WEAKER than default drive

00 DEFAULT drive strength

11 STRONGER than default drive strength (recommended for load capacitances > 5 pF)

10 MAXIMUM drive strength (recommended for load capacitances > 5 pF)

D3–D2 <LVDS CURRENT> **LVDS Current programmability**

00 3.5 mA

01 2.5 mA

10 4.5 mA

11 1.75 mA

D5–D4 <CURRENT DOUBLE> **LVDS Current double control**

00 default current, set by <LVDS CURR>

01 LVDS clock buffer current is doubled, 2x <LVDS CURR>

10 LVDS data and clock buffers current are doubled, 2x <LVDS CURR>

11 unused

Table 11.

| A7–A0 (hex) | D7 | D6 | D5 | D4 | D3 | D2 | D1 | D0 |
|----------------|----|----|--|----|----|----|----|----|
| 12 | 0 | 0 | <LVDS TERMINATION> <i>Internal termination programmability</i> | | | | | |

D5–D3 <LVDS DATA TERM> **Internal termination control for data outputs**

| | |
|-----|-------------------------|
| 000 | No internal termination |
| 001 | 300 Ω |
| 010 | 180 Ω |
| 011 | 110 Ω |
| 100 | 150 Ω |
| 101 | 100 Ω |
| 110 | 81 Ω |
| 111 | 60 Ω |

D2–D0 <LVDS CLK TERM> **Internal termination control for clock output**

| | |
|-----|-------------------------|
| 000 | No internal termination |
| 001 | 300 Ω |
| 010 | 180 Ω |
| 011 | 110 Ω |
| 100 | 150 Ω |
| 101 | 100 Ω |
| 110 | 81 Ω |
| 111 | 60 Ω |

Table 12.

| A7–A0 (hex) | D7 | D6 | D5 | D4 | D3 | D2 | D1 | D0 |
|----------------|----|----|----|-----------------|----|----|----|----|
| 13 | 0 | 0 | 0 | <OFFSET FREEZE> | 0 | 0 | 0 | 0 |

D4 <OFFSET FREEZE> **Offset correction becomes inactive and the last estimated offset value is used to cancel the offset**

| | |
|---|----------------------------|
| 0 | Offset correction active |
| 1 | Offset correction inactive |

Table 13.

| A7–A0 (hex) | D7 | D6 | D5 | D4 | D3 | D2 | D1 | D0 |
|----------------|--------------------------------|----|--|-------------------------------------|---|-----------------------|----|----|
| 14 | <OVRD> <i>Over-ride bit</i> | 0 | <OUTPUT INTERFACE> <i>LVDS or CMOS interface</i> | <COARSE GAIN> <i>3.5 dB gain</i> | <REF> <i>Internal / External reference</i> | <POWER DOWN MODES> | | |

D2-D0 <POWER DOWN MODES>

| | |
|-----|--|
| 000 | Normal operation |
| 001 | Channel A output buffer disabled |
| 010 | Channel B output buffer disabled |
| 011 | Channel A and B output buffers disabled |
| 100 | Global power down |
| 101 | Channel A standby |
| 110 | Channel B standby |
| 111 | Multiplexed mode, MUX – (only with CMOS interface) Channel A and B data is multiplexed and output on DB10 to DB0 pins. |

D3 <REF> Reference mode

| | |
|---|----------------------------|
| 0 | Internal reference enabled |
| 1 | External reference enabled |

D4 <COARSE GAIN> Coarse gain control

| | |
|---|--------------------|
| 0 | 0 dB coarse gain |
| 1 | 3.5 dB coarse gain |

D5 <OUTPUT INTERFACE> Output interface selection

| | |
|---|----------------------------|
| 0 | Parallel CMOS data outputs |
| 1 | DDR LVDS data outputs |

D7 <OVRD> Over-ride bit – the LVDS/CMOS selection, power down and MUX modes can also be controlled using parallel pins. By setting <OVRD> = 1, register bits LVDS <CMOS> and <POWER DOWN MODES> will over-ride the settings of the parallel pins.

| | |
|---|-------------------|
| 0 | Disable over-ride |
| 1 | Enable over-ride |

Table 14.

| A7–A0 (hex) | D7 | D6 | D5 | D4 | D3 | D2 | D1 | D0 |
|-------------|----|----|----|--|-----------------------------|-----------------|----|----|
| 16 | 0 | 0 | 0 | DATA FORMAT> 2s complement or straight binary | Bit / Byte wise (LVDS only) | <TEST PATTERNS> | | |

D2–D0 <TEST PATTERNS> Test Patterns to verify capture

- 000 Normal ADC operation
- 001 Outputs all zeros
- 010 Outputs all ones
- 011 Outputs toggle pattern
- 100 Outputs digital ramp
- 101 Outputs custom pattern
- 110 Unused
- 111 Unused

D3 Bit-wise/Byte-wise selection (DDR LVDS mode ONLY)

- 0 Bit wise – Odd bits (D1, D3, D5, D7, D9) on CLKOUT rising edge and Even bits (D0, D2, D4, D6, D8, D10) on CLKOUT falling edge
- 1 Byte wise – Lower 7 bits (D0-D6) at CLKOUT rising edge and Upper 4 bits (D7-D10) at CLKOUT falling edge

D4 <DATA FORMAT> Data format selection

- 0 2s complement
- 1 Straight binary

Table 15.

| A7–A0 (hex) | D7 | D6 | D5 | D4 | D3 | D2 | D1 | D0 |
|-------------|----|----|----|----|--|----|----|----|
| 17 | 0 | 0 | 0 | 0 | <FINE GAIN> 0 to 6 dB gain in 0.5 dB steps | | | |

D2–D0 <FINE GAIN> Gain programmability in 0.5 dB steps

- 0000 0 dB gain, default after reset
- 0001 0.5 dB gain
- 0010 1.0 dB gain
- 0011 1.5 dB gain
- 0100 2.0 dB gain
- 0101 2.5 dB gain
- 0110 3.0 dB gain
- 0111 3.5 dB gain
- 1000 4.0 dB gain
- 1001 4.5 dB gain
- 1010 5.0 dB gain
- 1011 5.5 dB gain
- 1100 6.0 dB gain
- Others Unused

Table 16.

| A7–A0 (hex) | D7 | D6 | D5 | D4 | D3 | D2 | D1 | D0 |
|-------------|--------------------------|----|----------------------------|----|----|----|----|----|
| 18 | <CUSTOM LOW> Lower 5bits | | | | | 0 | 0 | 0 |
| 19 | 0 | 0 | <CUSTOM HIGH> Upper 6 bits | | | | | |

D7-D4 <CUSTOM LOW>

5 lower bits of custom pattern available at the output instead of ADC data.

D5-D0 <CUSTOM HIGH>

6 upper bits of custom pattern available at the output instead of ADC data.

Table 17.

| A7-A0 (hex) | D7 | D6 | D5 | D4 | D3 | D2 | D1 | D0 |
|----------------|---------------|---|----|----|---|----|----|----|
| 1A | <LOW LATENCY> | <OFFSET TC> <i>Offset correction time constant</i> | | | <GAIN CORRECTION> <i>0 to 0.5 dB, steps of 0.05 dB</i> | | | |

D2-D0 <GAIN CORRECTION> **Enables fine gain correction in steps of 0.05 dB (same correction applies to both channels)**

0000 0 dB gain, default after reset

0001 +0.5 dB gain

0010 +0.10 dB gain

0011 +0.15 dB gain

0100 +0.20 dB gain

0101 +0.25 dB gain

0110 +0.30 dB gain

0111 +0.35 dB gain

1000 +0.40 dB gain

1001 +0.45 dB gain

1010 +0.5 dB gain

D6-D4 <OFFSET TC> **Time constant of offset correction in number of clock cycles (seconds, for sampling frequency = 125MSPS)**

 000 2^{27} (1.1 s)

 001 2^{26} (0.55 s)

 010 2^{25} (0.27 s)

 011 2^{24} (0.13 s)

 100 2^{28} (2.15 s)

 101 2^{29} (4.3 s)

 110 2^{27} (1.1 s)

 111 2^{27} (1.1 s)

D7 <LOW LATENCY>

0 Default latency, 13 clock cycles

1 Low latency enabled, 9 clock cycles – Digital Processing Block is bypassed.

Table 18.

| A7-A0 (hex) | D7 | D6 | D5 | D4 | D3 | D2 | D1 | D0 |
|-------------|---|----|--|--|------------------|---|----|----|
| 1B | <OFFSET Enable> Offset correction enable | 0 | <FILTER COEFF SELECT> In-built or custom coefficients | <DECIMATION Enable> Enable decimation | <ODD TAP Enable> | <DECIMATION RATE> <i>Decimate by 2,4,8</i> | | |

- D2-D0** <DECIMATION RATE> [Decimation filters](#)
- 000 Decimate by 2 (pre-defined or user coefficients can be used)
 - 001 Decimate by 4 (pre-defined or user coefficients can be used)
 - 011 No decimation (Pre-defined coefficients are disabled, only custom coefficients are available)
 - 100 Decimate by 8 (Only custom coefficients are available)
- D3** <ODD TAP ENABLE>
- 0 Even taps enabled (24 coefficients)
 - 1 0 Odd taps enabled (23 coefficients)
- D4** <DECIMATION ENABLE>
- 0 Decimation disabled
 - 1 0 Decimation enabled
- D5** <FILTER COEFF SELECT>
- 0 Pre-defined coefficients are loaded in the filter
 - 1 User-defined coefficients are loaded in the filter (coefficients have to be loaded in registers – to -)
- D7** <OFFSET Enable>
- 0 Offset correction disabled
 - 1 Offset correction enabled

Table 19.

| A7-A0 (hex) | D7 | D6 | D5 | D4 | D3 | D2 | D1 | D0 |
|-------------|----|----|----|----|----|----|--------------------------------|----|
| 1D | 0 | 0 | 0 | 0 | 0 | 0 | <DECIMATION FILTER FREQ BANDS> | |

- D1-D0** <DECIMATION FILTER FREQ BAND> [Decimation filters](#)
- With decimate by 2, <DECIMATION RATE> = 000:
- 00 Low pass filter (-6 dB frequency at $F_s/4$)
 - 01 High pass filter (-6 dB frequency at $F_s/4$)
 - 10, 11 Unused
- With decimate by 4, <DECIMATION RATE> = 001:
- 00 Low pass filter (-3 dB frequency at $F_s/8$)
 - 01 Band pass filter (center frequency at $3F_s/16$)
 - 10 Band pass filter (center frequency at $5F_s/16$)
 - 11 High pass filter (-3 dB frequency at $3F_s/8$)

PIN DESCRIPTION (CMOS INTERFACE)

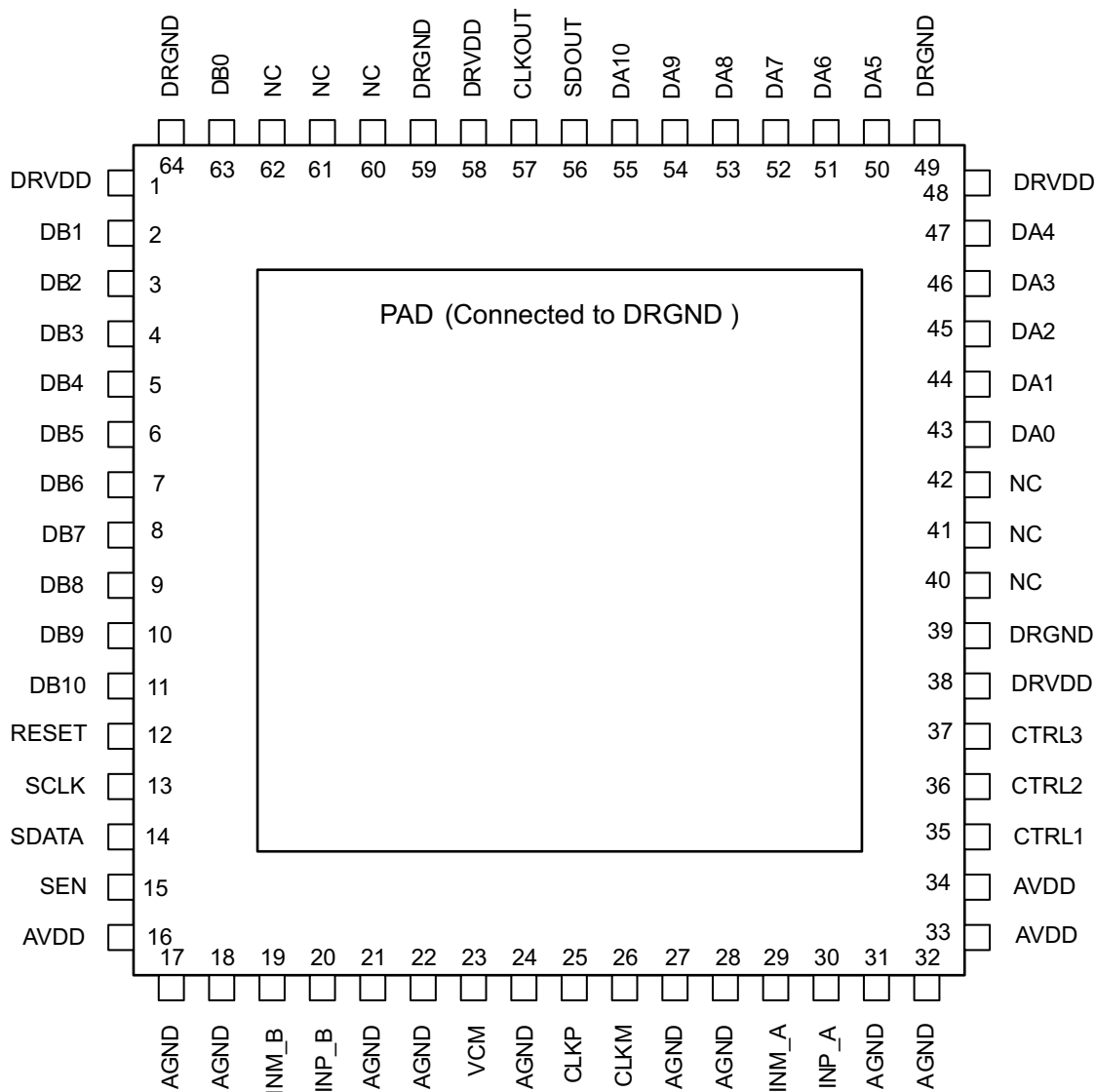

Pin Assignments (CMOS INTERFACE)

| PIN NAME | DESCRIPTION | PIN NUMBER | NUMBER OF PINS |
|--------------|--|------------------------------------|----------------|
| AVDD | Analog power supply | 16, 33, 34 | 3 |
| AGND | Analog ground | 17, 18, 21, 22, 24, 27, 28, 31, 32 | 9 |
| CLKP, CLKM | Differential input clock | 25, 26 | 2 |
| INM_A, INP_A | Differential input signal – channel A. When not used, the analog input pins (INM_A, INP_A) MUST be tied to VCM and CANNOT be floated. | 29, 30 | 2 |
| INM_B, INP_B | Differential input signal – channel B. When not used, the analog input pins (INM_B, INP_B) MUST be tied to VCM and CANNOT be floated. | 19, 20 | 2 |
| VCM | Internal reference mode – Common-mode voltage output. External reference mode – Reference input. The voltage forced on this pin sets the ADC internal references. | 23 | 1 |
| RESET | Serial interface RESET input. In serial interface mode, the user must initialize internal registers through hardware RESET by applying a high-going pulse on this pin or by using software reset (refer to Serial Interface section). In parallel interface mode, the user has to tie RESET pin permanently high . (SCLK, SDATA and SEN are used as parallel pin controls in this mode) The pin has an internal 100 kΩ pull-down resistor. | 12 | 1 |
| SCLK | This pin functions as serial interface clock input when RESET is low . It functions as analog control pin when RESET is tied high & controls coarse gain and internal/external reference selection. See Table 4 for details. The pin has an internal pull-down resistor to ground. | 13 | 1 |
| SDATA | This pin functions as serial interface data input when RESET is low. The pin has an internal pull-down resistor to ground. | 14 | 1 |
| SEN | This pin functions as serial interface enable input when RESET is low . It functions as analog control pin when RESET is tied high & controls the output interface (LVDS/CMOS) and data format selection. See Table 5 for details. The pin has an internal pull-up resistor to AVDD. | 15 | 1 |
| CTRL1 | These are digital logic input pins. Together they control various power down and multiplexed mode. see Table 6 for details | 35 | 1 |
| CTRL2 | | 36 | 1 |
| CTRL3 | | 37 | 1 |
| DA0 to DA10 | Channel A 11-bit data outputs, CMOS | 43 - 47, 50 - 55 | 11 |
| DB0 to DB10 | Channel B 11-bit data outputs, CMOS | 63, 2 - 11 | 11 |
| CLKOUT | CMOS Output clock | 57 | 1 |
| DRVDD | Digital supply | 1, 38, 48, 58 | 4 |
| DRGND | Digital ground | 39, 49, 59, 64 and PAD | 4 |
| PAD | Digital ground. Solder the pad to the digital ground on the board using multiple vias for good electrical and thermal performance. | – | 1 |
| SDOUT | It functions as serial data readout pin ONLY when <SERIAL READOUT> =1. When <SERIAL READOUT> = 0, SDOUT pin is forced low or high by the device (and not put in high-impedance state). If serial readout is not used, SDOUT pin has to be floated & should not be connected on the board. | 56 | 1 |
| NC | Do not connect | 40, 41, 42, 60, 61, 62 | 7 |

PIN DESCRIPTION (LVDS INTERFACE)

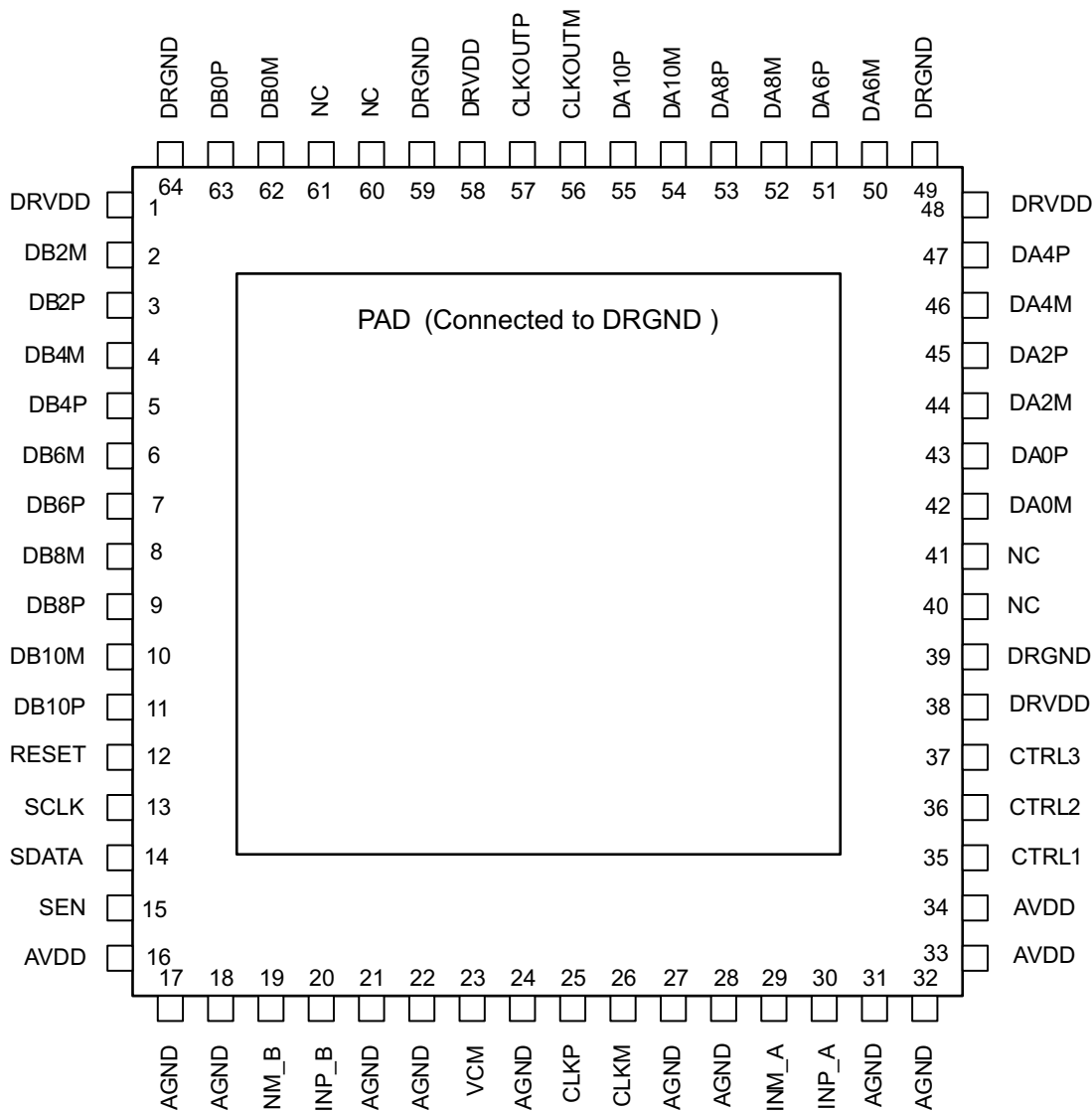

Pin Assignments (LVDS INTERFACE)

| PIN NAME | DESCRIPTION | PIN NUMBER | NUMBER OF PINS |
|--------------|--|------------------------------------|----------------|
| AVDD | Analog power supply | 16, 33, 34 | 3 |
| AGND | Analog ground | 17, 18, 21, 22, 24, 27, 28, 31, 32 | 9 |
| CLKP, CLKM | Differential input clock | 25, 26 | 2 |
| INM_A, INP_A | Differential input signal – Channel A. When not used, the analog input pins (INM_A, INP_A) MUST be tied to VCM and CANNOT be floated. | 29, 30 | 2 |
| INM_B, INP_B | Differential input signal – Channel B. When not used, the analog input pins (INM_B, INP_B) MUST be tied to VCM and CANNOT be floated. | 19, 20 | 2 |
| VCM | Internal reference mode – Common-mode voltage output. External reference mode – Reference input. The voltage forced on this pin sets the ADC internal references. | 23 | 1 |

Pin Assignments (LVDS INTERFACE) (continued)

| PIN NAME | DESCRIPTION | PIN NUMBER | NUMBER OF PINS |
|----------|--|----------------|----------------|
| RESET | Serial interface RESET input. In serial interface mode, the user must initialize internal registers through hardware RESET by applying a high-going pulse on this pin or by using software reset (refer to Serial Interface section). In parallel interface mode, the user has to tie RESET pin permanently high . (SCLK, SDATA and SEN are used as parallel pin controls in this mode) The pin has an internal 100 kΩ pull-down resistor. | 12 | 1 |
| SCLK | This pin functions as serial interface clock input when RESET is low . It functions as analog control pin when RESET is tied high & controls coarse gain and internal/external reference selection. See Table 4 for details. The pin has an internal pull-down resistor to ground. | 13 | 1 |
| SDATA | This pin functions as serial interface data input when RESET is low. The pin has an internal pull-down resistor to ground. | 14 | 1 |
| SEN | This pin functions as serial interface enable input when RESET is low . It functions as analog control pin when RESET is tied high & controls the output interface (LVDS/CMOS) and data format selection. See Table 5 for details. The pin has an internal pull-up resistor to AVDD. | 15 | 1 |
| CTRL1 | These are digital logic input pins. Together they control various power down and multiplexed mode. See Table 6 for details. | 35 | 1 |
| CTRL2 | | 36 | 1 |
| CTRL3 | | 37 | 1 |
| NC | Do not connect | 40, 41, 60, 61 | 4 |
| DA0P | Channel A Differential output data 0 and D0 multiplexed, true | 43 | 1 |
| DA0M | Channel A Differential output data 0 and D0 multiplexed, complement | 42 | 1 |
| DA2P | Channel A Differential output data D1 and D2 multiplexed, true | 45 | 1 |
| DA2M | Channel A Differential output data D1 and D2 multiplexed, complement | 44 | 1 |
| DA4P | Channel A Differential output data D3 and D4 multiplexed, true | 47 | 1 |
| DA4M | Channel A Differential output data D3 and D4 multiplexed, complement | 46 | 1 |
| DA6P | Channel A Differential output data D5 and D6 multiplexed, true | 51 | 1 |
| DA6M | Channel A Differential output data D5 and D6 multiplexed, complement | 50 | 1 |
| DA8P | Channel A Differential output data D7 and D8 multiplexed, true | 53 | 1 |
| DA8M | Channel A Differential output data D7 and D8 multiplexed, complement | 52 | 1 |
| DA10P | Channel A Differential output data D9 and D10 multiplexed, true | 55 | 1 |
| DA10M | Channel A Differential output data D9 and D10 multiplexed, complement | 54 | 1 |
| CLKOUTP | Differential output clock, true | 57 | 1 |
| CLKOUTM | Differential output clock, complement | 56 | 1 |
| DB0P | Channel B Differential output data 0 and D0 multiplexed, true | 63 | 1 |
| DB0M | Channel B Differential output data 0 and D0 multiplexed, complement | 62 | 1 |
| DB2P | Channel B Differential output data D1 and D2 multiplexed, true | 3 | 1 |
| DB2M | Channel B Differential output data D1 and D2 multiplexed, complement | 2 | 1 |
| DB4P | Channel B Differential output data D3 and D4 multiplexed, true | 5 | 1 |
| DB4M | Channel B Differential output data D3 and D4 multiplexed, complement | 4 | 1 |
| DB6P | Channel B Differential output data D5 and D6 multiplexed, true | 7 | 1 |
| DB6M | Channel B Differential output data D5 and D6 multiplexed, complement | 6 | 1 |
| DB8P | Channel B Differential output data D7 and D8 multiplexed, true | 9 | 1 |
| DB8M | Channel B Differential output data D7 and D8 multiplexed, complement | 8 | 1 |
| DB10P | Channel B Differential output data D9 and D10 multiplexed, true | 11 | 1 |
| DB10M | Channel B Differential output data D9 and D10 multiplexed, complement | 10 | 1 |
| DRVDD | Digital supply | 1, 38, 48, 58 | 4 |

Pin Assignments (LVDS INTERFACE) (continued)

| PIN NAME | DESCRIPTION | PIN NUMBER | NUMBER OF PINS |
|----------|--|------------------------|----------------|
| DRGND | Digital ground | 39, 49, 59, 64 and PAD | 4 |
| PAD | Digital ground. Solder the pad to the digital ground on the board using multiple vias for good electrical and thermal performance. | – | 1 |

TYPICAL CHARACTERISTICS

All plots are at 25°C, AVDD = 3.3V, DRVDD = 3.3V, sampling frequency = 125 MSPS, sine wave clock, 50% clock duty cycle, -1dBFS differential analog input, internal reference mode, 0 dB gain, applies to CMOS and LVDS interfaces (unless otherwise noted).

SPECTRUM FOR 20MHZ INPUT SIGNAL

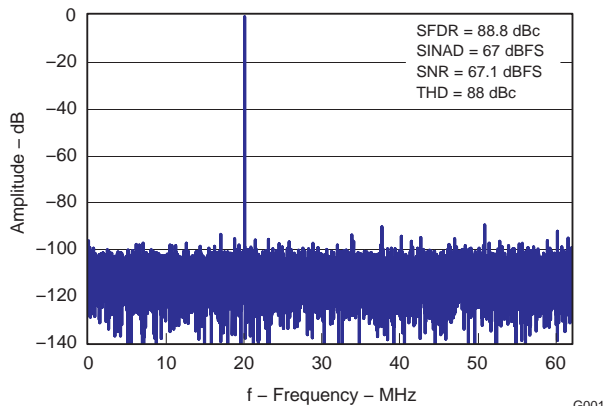

Figure 10.

SPECTRUM FOR 70MHZ INPUT SIGNAL

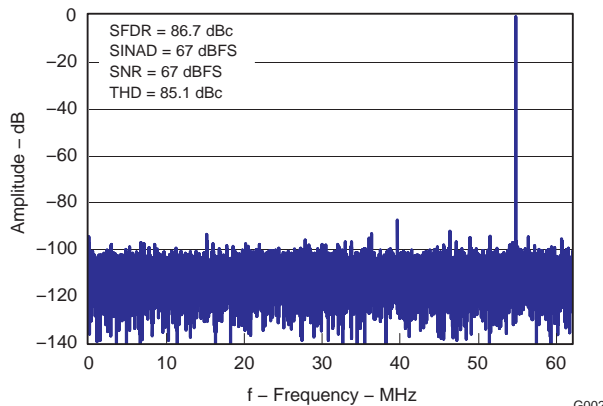

Figure 11.

SPECTRUM FOR 190MHZ INPUT SIGNAL

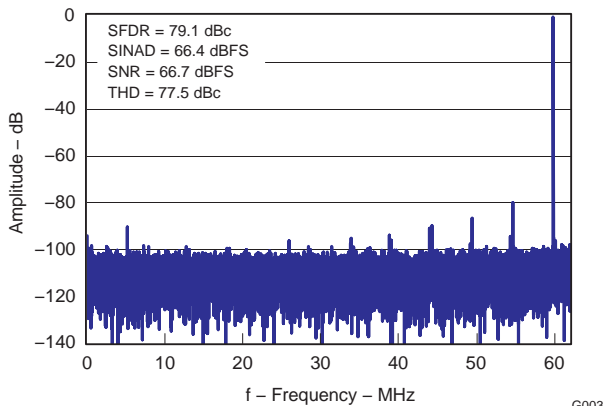

Figure 12.

SPECTRUM FOR 2-TONE INPUT SIGNAL (INTERMODULATION DISTORTION)

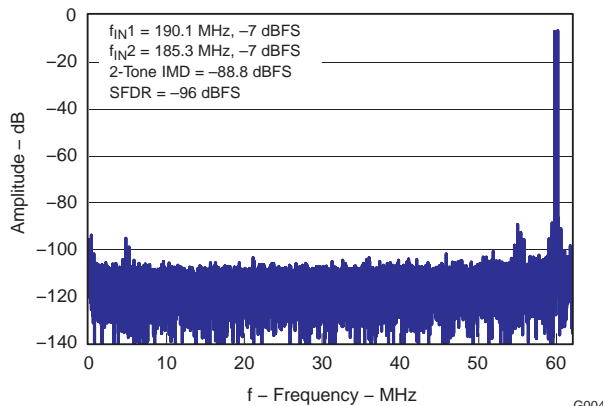

Figure 13.

TYPICAL CHARACTERISTICS (continued)

All plots are at 25°C, AVDD = 3.3V, DRVDD = 3.3V, sampling frequency = 125 MSPS, sine wave clock, 50% clock duty cycle, -1dBFS differential analog input, internal reference mode, 0 dB gain, applies to CMOS and LVDS interfaces (unless otherwise noted).

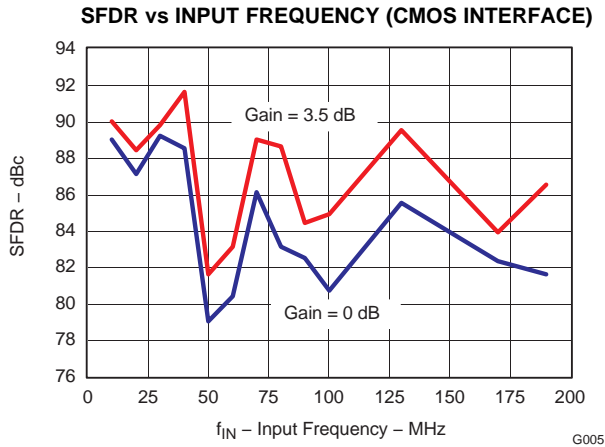

Figure 14.

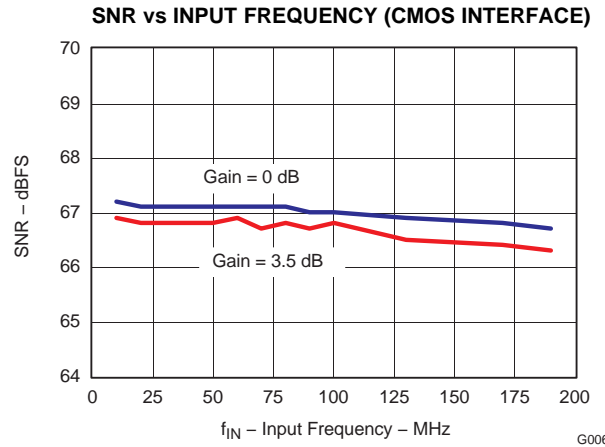

Figure 15.

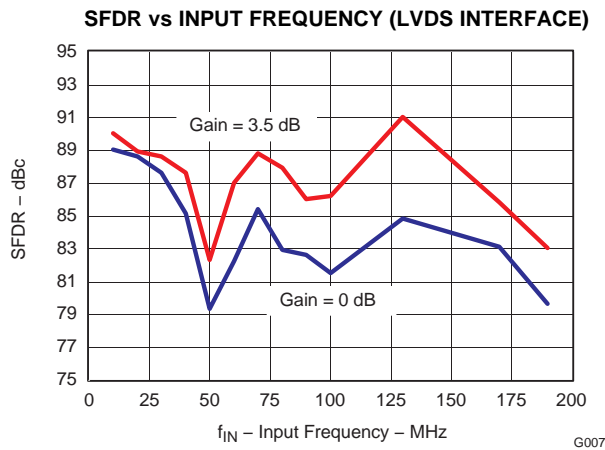

Figure 16.

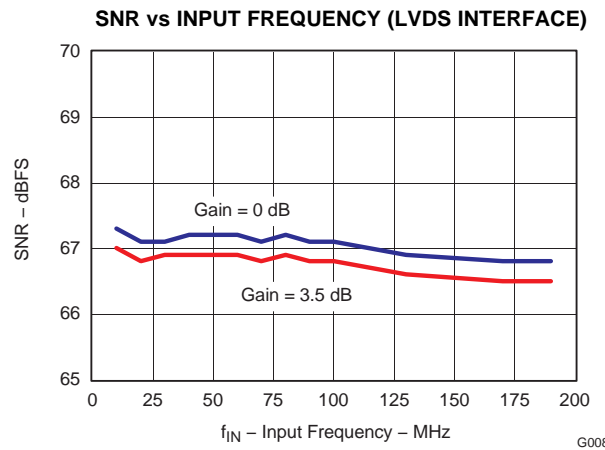

Figure 17.

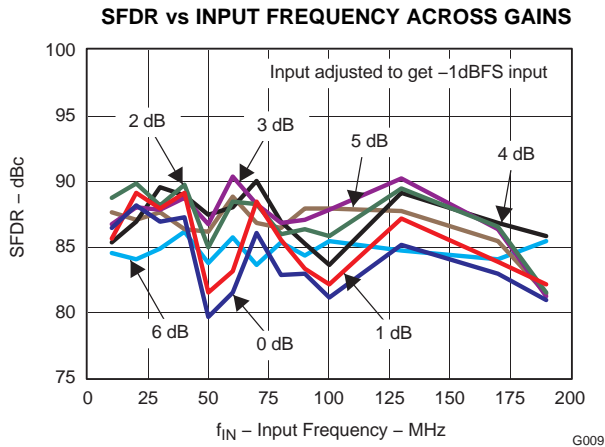

Figure 18.

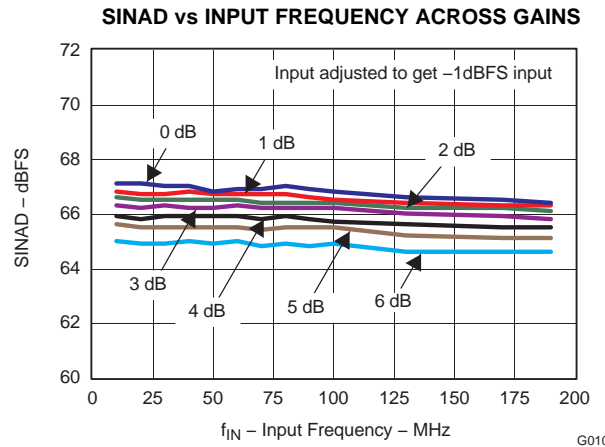

Figure 19.

TYPICAL CHARACTERISTICS (continued)

All plots are at 25°C, AVDD = 3.3V, DRVDD = 3.3V, sampling frequency = 125 MSPS, sine wave clock, 50% clock duty cycle, -1dBFS differential analog input, internal reference mode, 0 dB gain, applies to CMOS and LVDS interfaces (unless otherwise noted).

PERFORMANCE vs AVDD SUPPLY

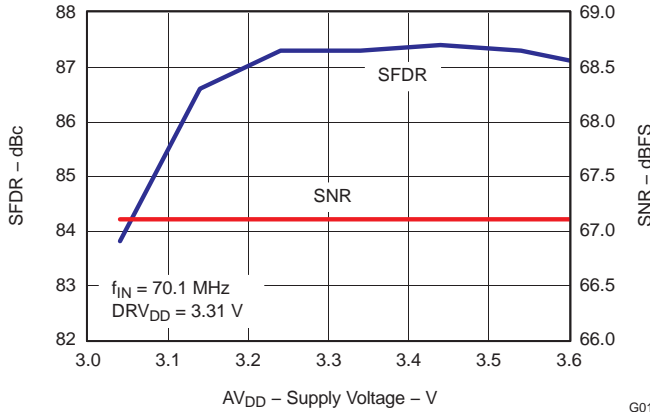

Figure 20.

PERFORMANCE vs DRVDD SUPPLY

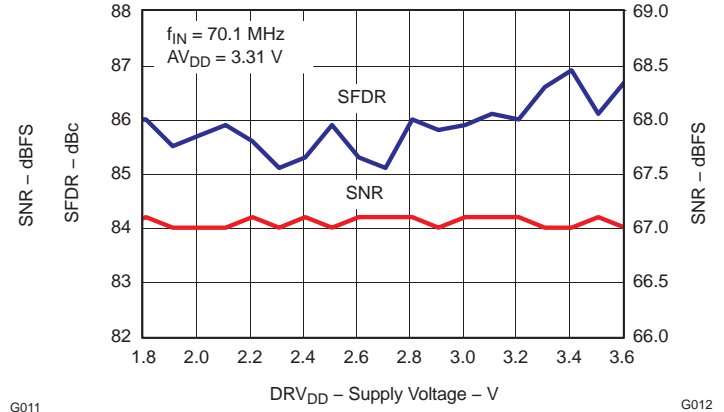

Figure 21.

PERFORMANCE vs TEMPERATURE

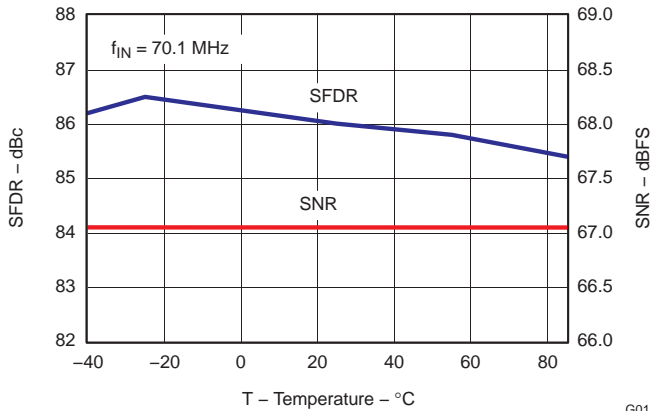

Figure 22.

PERFORMANCE vs INPUT AMPLITUDE

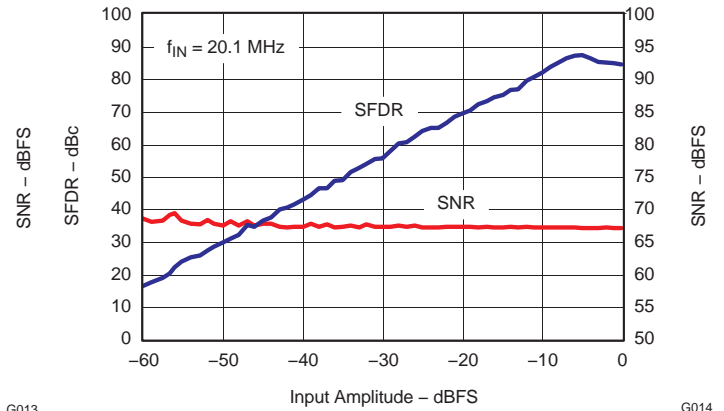

Figure 23.

PERFORMANCE vs INPUT CLOCK AMPLITUDE

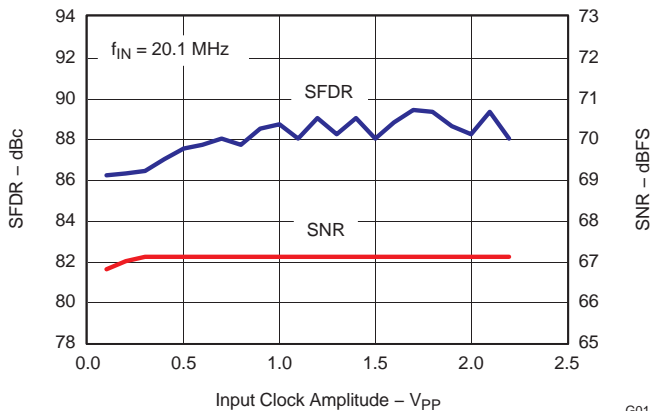

Figure 24.

PERFORMANCE vs INPUT CLOCK DUTY CYCLE

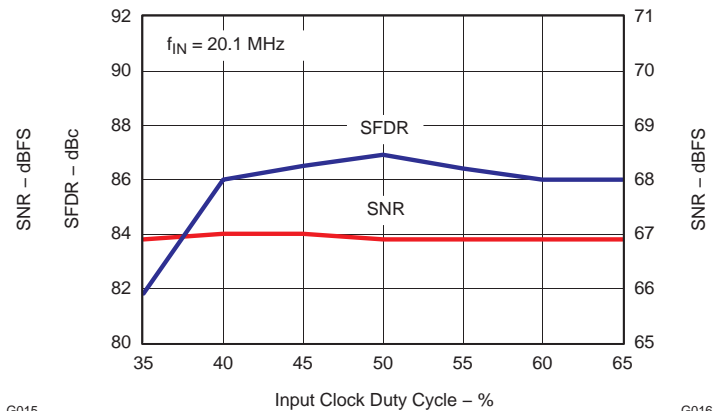

Figure 25.

TYPICAL CHARACTERISTICS (continued)

All plots are at 25°C, AVDD = 3.3V, DRVDD = 3.3V, sampling frequency = 125 MSPS, sine wave clock, 50% clock duty cycle, -1dBFS differential analog input, internal reference mode, 0 dB gain, applies to CMOS and LVDS interfaces (unless otherwise noted).

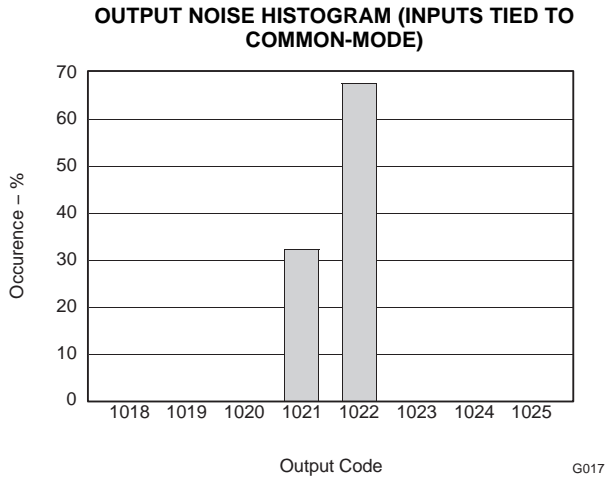

Figure 26.

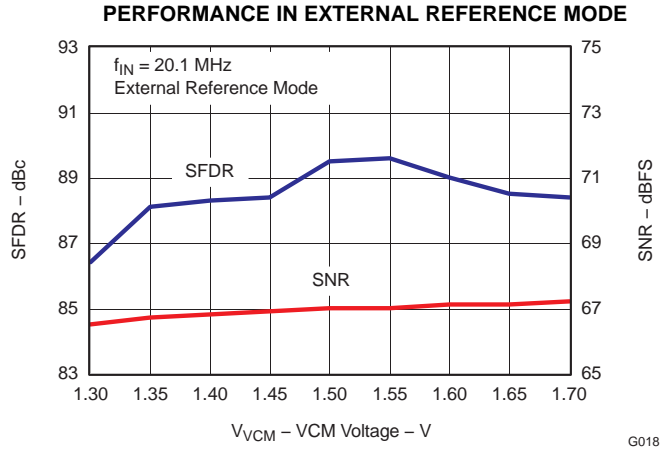

Figure 27.

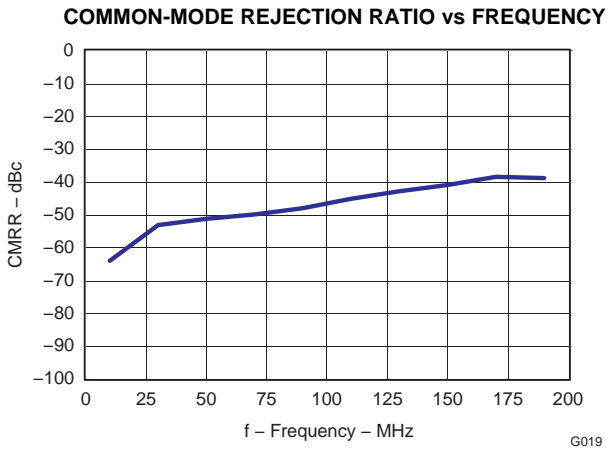

Figure 28.

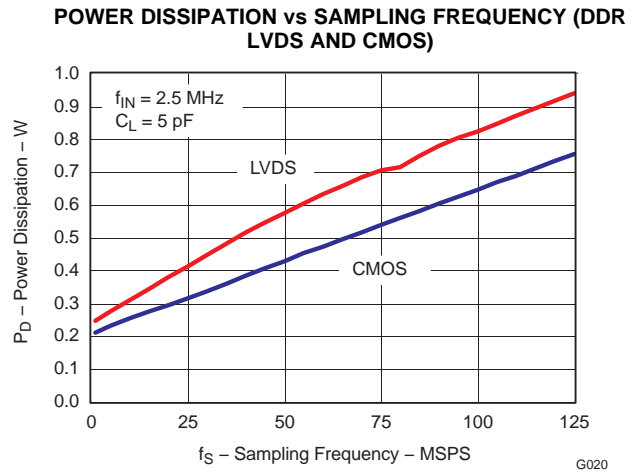

Figure 29.

DRVDD CURRENT vs SAMPLING FREQUENCY ACROSS LOAD CAPACITANCE (CMOS)

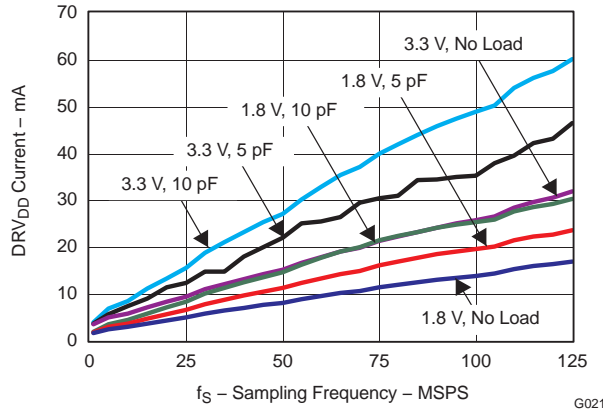

Figure 30.

APPLICATION INFORMATION

THEORY OF OPERATION

ADS62P15 is a low power 11-bit dual channel pipeline ADC family fabricated in a CMOS process using switched capacitor techniques.

The conversion process is initiated by a rising edge of the external input clock. Once the signal is captured by the input sample and hold, the input sample is sequentially converted by a series of small resolution stages, with the outputs combined in a digital correction logic block. At every clock edge the sample propagates through the pipeline resulting in a data latency of 14 clock cycles. The output is available as 11-bit data, in DDR LVDS or CMOS and coded in either straight offset binary or binary 2s complement format.

ANALOG INPUT

The analog input consists of a switched-capacitor based differential sample and hold architecture.

This differential topology results in very good AC performance even for high input frequencies at high sampling rates. The INP and INM pins have to be externally biased around a common-mode voltage of 1.5V, available on VCM pin 13. For a full-scale differential input, each input pin INP, INM has to swing symmetrically between $V_{CM} + 0.5V$ and $V_{CM} - 0.5V$, resulting in a $2V_{PP}$ differential input swing. The maximum swing is determined by the internal reference voltages REFP (2.5V nominal) and REFM (0.5V, nominal).

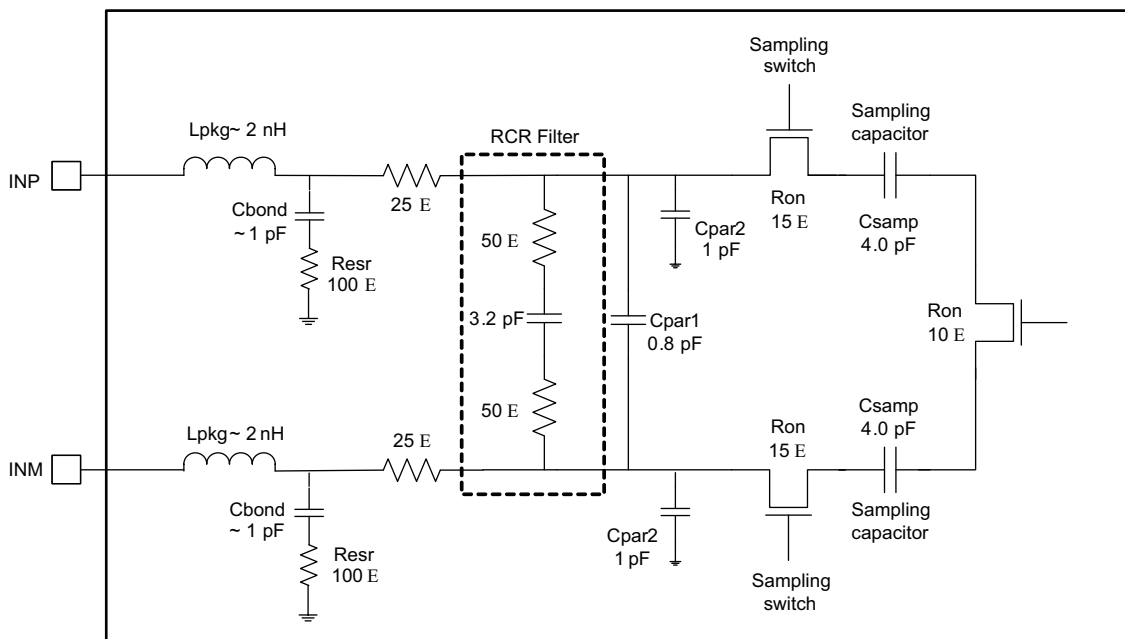

Figure 31. Analog Input Equivalent Circuit

The input sampling circuit has a high 3-dB bandwidth that extends up to 450 MHz (measured from the input pins to the sampled voltage).

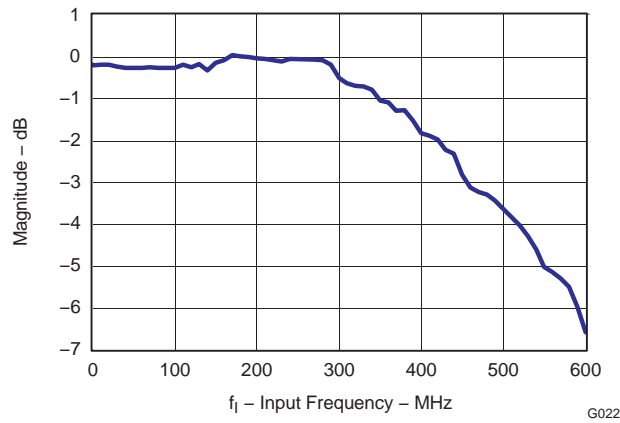

Figure 32. ADC Analog Bandwidth

Drive Circuit Requirements

For optimum performance, the analog inputs must be driven differentially. This improves the common-mode noise immunity and even order harmonic rejection. A <math> < 5 \Omega </math> resistor in series with each input pin is recommended to damp out ringing caused by the package parasitics.

It is also necessary to present low impedance (50Ω) for the common mode switching currents. This can be achieved by using two resistors from each input terminated to the common mode voltage (VCM).

In addition, the drive circuit may have to be designed to provide a low insertion loss over the desired frequency range and matched impedance to the source. While doing this, the ADC input impedance must be considered. [Figure 33](#) and [Figure 34](#) show the impedance ($Z_{in} = R_{in} || C_{in}$) looking into the ADC input pins.

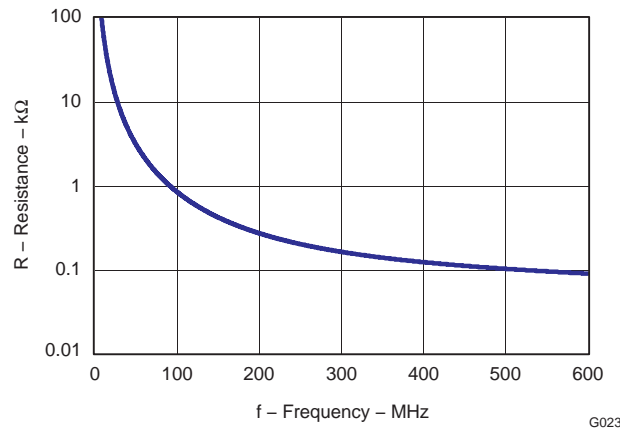

Figure 33. ADC Analog Input Resistance (R_{in}) Across Frequency

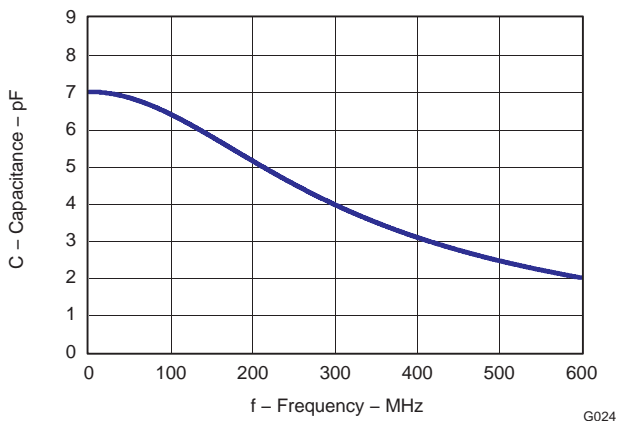

Figure 34. ADC Analog Input Capacitance (C_{in}) Across Frequency

Using RF-Transformer Based Drive Circuits

Figure 35 shows a configuration using a single 1:1 turns ratio transformer (for example, Coilcraft WBC1-1) that can be used for low input frequencies (about 100 MHz). The single-ended signal is fed to the primary winding of the RF transformer. The transformer is terminated on the secondary side. Putting the termination on the secondary side helps to shield the kickbacks caused by the sampling circuit from the RF transformer’s leakage inductances. The termination is accomplished by two resistors connected in series, with the center point connected to the 1.5 V common mode (VCM pin). The value of the termination resistors (connected to common mode) has to be low (<100 Ω) to provide a low-impedance path for the ADC common-mode switching currents.

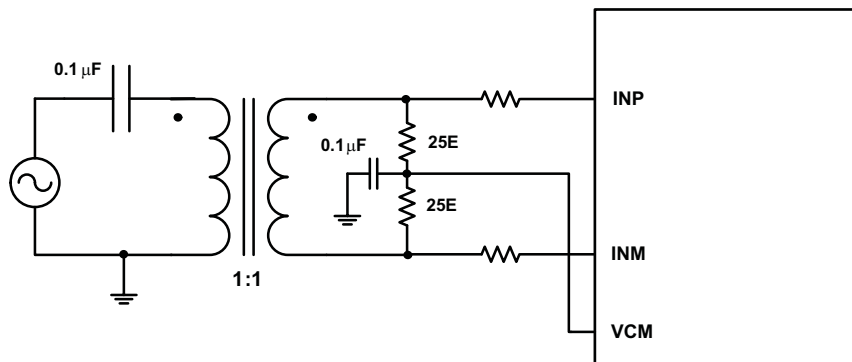

Figure 35. Drive Circuit at Low Input Frequencies

At high input frequencies, the mismatch in the transformer parasitic capacitance (between the windings) results in degraded even-order harmonic performance. Connecting two identical RF transformers back-to-back helps minimize this mismatch, and good performance is obtained for high frequency input signals. Figure 36 shows an example using two transformers (Coilcraft WBC1-1). An additional termination resistor pair (enclosed within the shaded box) may be required between the two transformers to improve the balance between the P and M sides. The center point of this termination must be connected to ground.

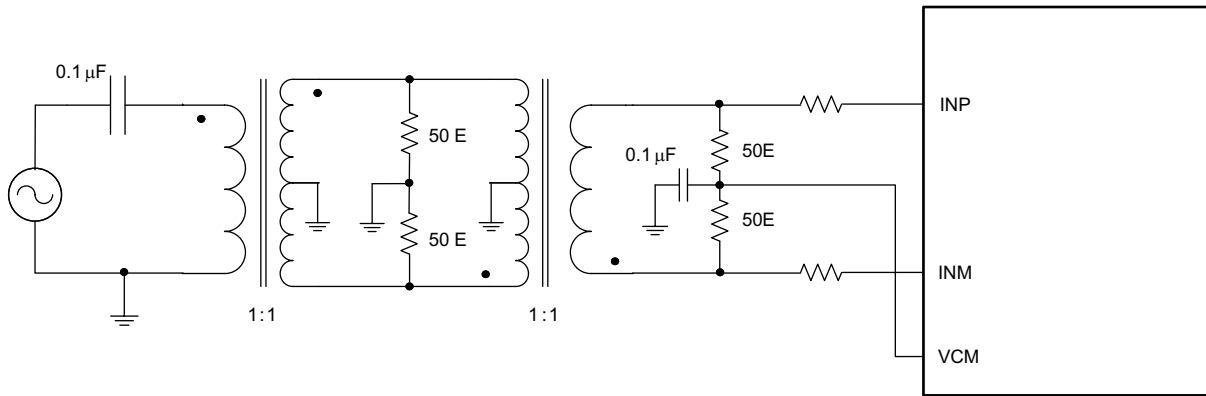

Figure 36. Drive Circuit at High Input Frequencies

Using Differential Amplifier Drive Circuits

Figure 37 shows a drive circuit using a differential amplifier (TI's THS4509) to convert a single-ended input to differential output that can be interface to the ADC analog input pins. In addition to the single-ended to differential conversion, the amplifier also provides gain (10 dB). RFIL helps to isolate the amplifier outputs from the switching input of the ADC. Together with CFIL it also forms a low-pass filter that band-limits the noise (and signal) at the ADC input. As the amplifier output is ac-coupled, the common-mode voltage of the ADC input pins is set using two 200 Ω resistors connected to VCM.

The amplifier output can also be dc-coupled. Using the output common-mode control of the THS4509, the ADC input pins can be biased to 1.5 V. In this case, use +4 V and -1 V supplies for the THS4509 so that its output common-mode voltage (1.5 V) is at mid-supply.

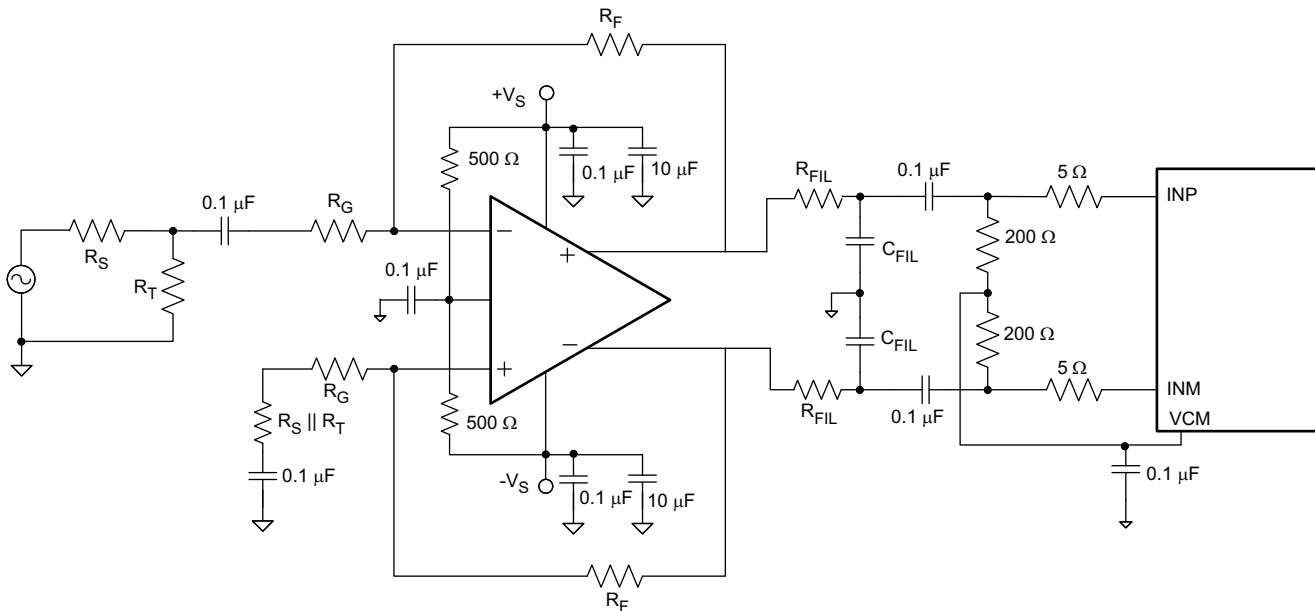

Figure 37. Drive Circuit Using the THS4509

Input Common-Mode

To ensure a low-noise common-mode reference, the VCM pin is filtered with a 0.1 μF low-inductance capacitor connected to ground. The VCM pin is designed to directly drive the ADC inputs. The input stage of the ADC sinks a common-mode current in the order of 165 μA (at 125 MSPS). Equation 1 describes the dependency of the common-mode current and the sampling frequency.

$$\frac{165 \mu\text{A} \times F_s}{125 \text{ MSPS}} \quad (1)$$

This equation helps to design the output capability and impedance of the CM driving circuit accordingly.

REFERENCE

ADS62P15 has built-in internal references REFP and REFM, requiring no external components. Design schemes are used to linearize the converter load seen by the references; this and the on-chip integration of the requisite reference capacitors eliminates the need for external decoupling. The full-scale input range of the converter can be controlled in the external reference mode as explained below. The internal or external reference modes can be selected by programming the serial interface register bit ([REF](#)).

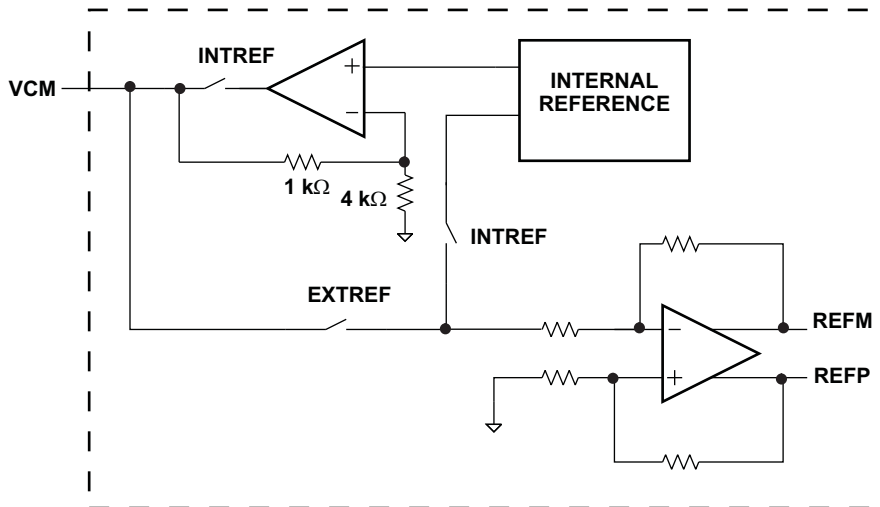

Figure 38. Reference Section

Internal Reference

When the device is in internal reference mode, the REFP and REFM voltages are generated internally. Common-mode voltage (1.5V nominal) is output on VCM pin, which can be used to externally bias the analog input pins.

External Reference

When the device is in external reference mode, the VCM acts as a reference input pin. The voltage forced on the VCM pin is buffered and gained by 1.33 internally, generating the REFP and REFM voltages. The differential input voltage corresponding to full-scale is given in [Equation 2](#).

$$\text{Full-scale differential input pp} = (\text{Voltage forced on VCM}) \times 1.33 \quad (2)$$

In this mode, the 1.5V common-mode voltage to bias the input pins has to be generated externally.

COARSE GAIN AND PROGRAMMABLE FINE GAIN

ADS62P15 includes gain settings that can be used to get improved SFDR performance (over 0dB gain mode). For each gain setting, the analog input full-scale range scales proportionally, as shown in [Table 20](#).

The coarse gain is a fixed setting of 3.5 dB and is designed to improve SFDR with little degradation in SNR. The fine gain is programmable in 0.5 dB steps from 0 to 6 dB; however the SFDR improvement is achieved at the expense of SNR. So, the programmable fine gain makes it possible to trade-off between SFDR and SNR. The coarse gain makes it possible to get best SFDR but without losing SNR significantly.

The gains can be programmed using the serial interface (bits [COARSE GAIN](#) and [FINE GAIN](#)). Note that the default gain after reset is 0dB.

Table 20. Full-Scale Range Across Gains

| GAIN, dB | TYPE | FULL-SCALE, V _{PP} |
|----------|---------------------|-----------------------------|
| 0 | Default after reset | 2V |
| 3.5 | Coarse (fixed) | 1.34 |
| 0.5 | Fine (programmable) | 1.89 |
| 1.0 | | 1.78 |
| 1.5 | | 1.68 |
| 2.0 | | 1.59 |
| 2.5 | | 1.50 |
| 3.0 | | 1.42 |
| 3.5 | | 1.34 |
| 4.0 | | 1.26 |
| 4.5 | | 1.19 |
| 5.0 | | 1.12 |
| 5.5 | | 1.06 |
| 6.0 | | 1.00 |

CLOCK INPUT

The clock inputs can be driven differentially (SINE, LVPECL or LVDS) or single-ended (LVCMOS), with little or no difference in performance between them. The common-mode voltage of the clock inputs is set to VCM using internal 5 kΩ resistors as shown in Figure 39. This allows using transformer-coupled drive circuits for sine wave clock or ac-coupling for LVPECL, LVDS clock sources (Figure 41 and Figure 42).

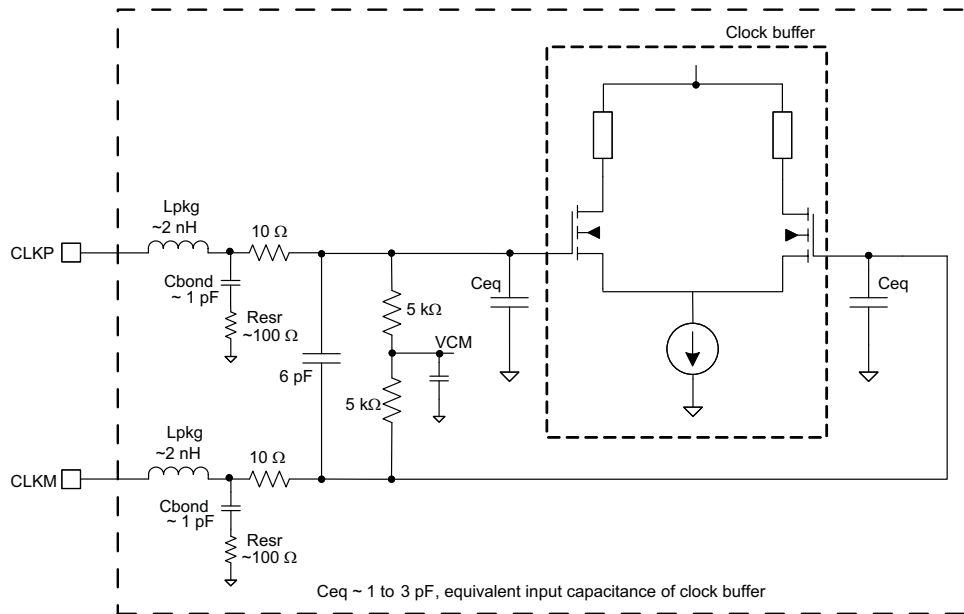

Figure 39. Internal Clock Buffer

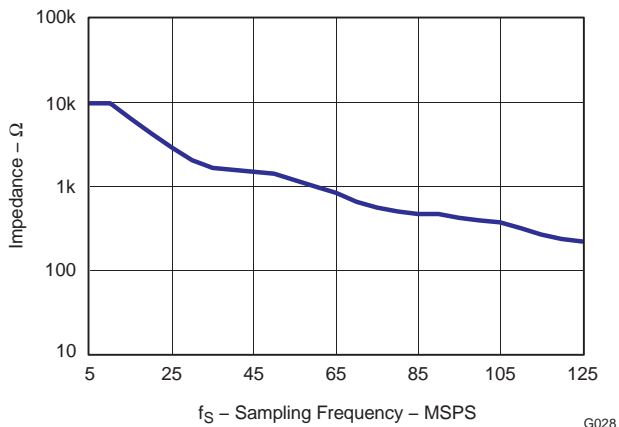

Figure 40. Clock Input Impedance

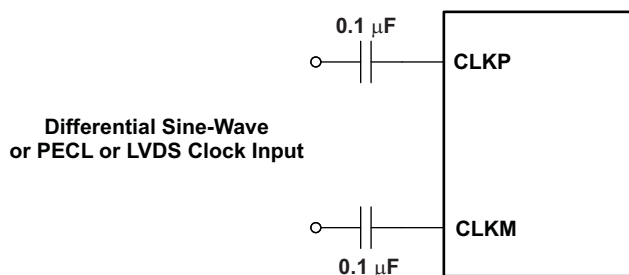

Figure 41. Differential Clock Driving Circuit

Single-ended CMOS clock can be ac-coupled to the CLKP input, with CLKM connected to ground with a 0.1-μF capacitor, as shown in Figure 42.

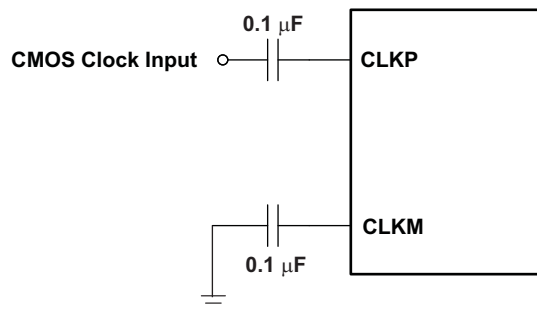

Figure 42. Single-Ended Clock Driving Circuit

For best performance, the clock inputs have to be driven differentially, reducing susceptibility to common-mode noise. For high input frequency sampling, it is recommended to use a clock source with very low jitter. Bandpass filtering of the clock source can help reduce the effect of jitter. There is no change in performance with a non-50% duty cycle clock input.

POWER DOWN

ADS62P15 has three power down modes – power down global, individual channel standby and individual channel output buffer disable. These can be set using either the serial register bits or using the control pins CTRL1 to CTRL3.

Table 21. Power Down Modes

| POWER DOWN MODES | CONFIGURE USING | | | | WAKE-UP TIME |
|---|--|-----------------------|-------|-------|-------------------|
| | SERIAL INTERFACE <POWER DOWN MODES> | PARALLEL CONTROL PINS | | | |
| | | CTRL1 | CTRL2 | CTRL3 | |
| Normal operation | 000 | low | low | low | — |
| Channel A output buffer disabled | 001 | low | low | high | Fast (100 ns) |
| Channel B output buffer disabled | 010 | low | high | low | Fast (100 ns) |
| Channel A and B output buffer disabled | 011 | low | high | high | Fast (100 ns) |
| Global power down | 100 | high | low | low | Slow (15 μ S) |
| Channel A standby | 101 | high | low | high | Fast (100 ns) |
| Channel B standby | 110 | high | high | low | Fast (100 ns) |
| Multiplexed (MUX) mode – Output data of channel A and B is multiplexed and available on DB10 to DB0 pins. | 111 | high | high | high | — |

Power Down Global

In this mode, the entire chip including both the A/D converters, internal reference and the output buffers are powered down resulting in reduced total power dissipation of about 50 mW. The output buffers are in high impedance state. The wake-up time from the global power down to data becoming valid in normal mode is typically 15 μ s.

Channel Standby (Individual or Both Channels)

This mode allows the individual ADCs to be powered down. The internal references are active & this results in fast wake-up time, about 100 ns. The total power dissipation in standby is about 482 mW.

Output Buffer Disable (Individual or Both Channels)

Each channel’s output buffer can be disabled and put in high impedance state -- wakeup time from this mode is fast, about 100 ns.

Input Clock Stop

In addition to the above, the converter enters a low-power mode when the input clock frequency falls below 1 MSPS. The power dissipation is about 140 mW.

POWER SUPPLY SEQUENCE

During power-up, the AVDD and DRVDD supplies can come up in any sequence. The two supplies are separated in the device. Externally, they can be driven from separate supplies or derived from a single supply.

DIGITAL OUTPUT INFORMATION

ADS62P15 provides 11 bit data per channel and a common output clock synchronized with the data. The output interface can be either parallel CMOS or DDR LVDS voltage levels and can be selected using serial register bit <OUTPUT INTERFACE> or parallel pin SEN.

Parallel CMOS Interface

In the CMOS mode, the output buffer supply (DRVDD) can be operated over a wide range from 1.8 V to 3.3 V (typical). Each data bit is output on separate pin as CMOS voltage level, every clock cycle (see Figure 43).

For DRVDD > 2.2 V, it is recommended to use the CMOS output clock (CLKOUT) to latch data in the receiving chip. The rising edge of CLKOUT can be used to latch data in the receiver, even at the highest sampling speed. It is recommended to minimize the load capacitance seen by data and clock output pins by using short traces to the receiver. Also, match the output data and clock traces to minimize the skew between them.

For DRVDD < 2.2 V, it is recommended to use external clock (for example, input clock delayed to get desired setup/hold times).

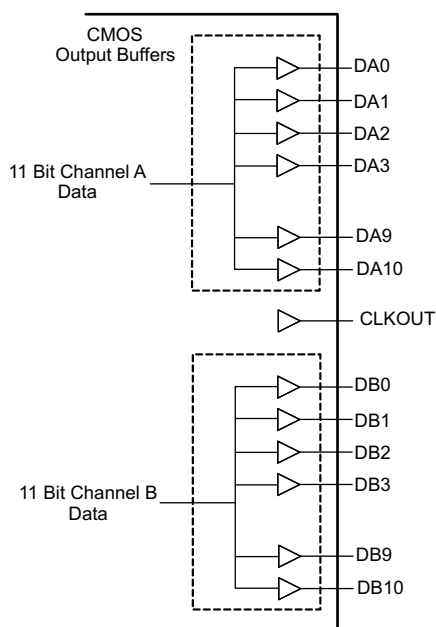

Figure 43. CMOS Output Interface

Output Buffer Strength Programmability

Switching noise (caused by CMOS output data transitions) can couple into the analog inputs during the instant of sampling and degrade the SNR. The coupling and SNR degradation increases as the output buffer drive is made stronger. To minimize this, ADS62P15 CMOS output buffers are designed with controlled drive strength to get best SNR. The default drive strength also ensures wide data stable window for load capacitances up to 5 pF and DRVDD supply voltage >2.2 V.

To ensure wide data stable window for load capacitance > 5 pF, there exists option to increase the output data and clock drive strengths using the serial interface ([DATAOUT STRENGTH](#) and [CLKOUT STRENGTH](#)). Note that for DRVDD supply voltage <2.2 V, it is recommended to use maximum drive strength (for any value of load capacitance).

CMOS Mode Power Dissipation

With CMOS outputs, the DRVDD current scales with the sampling frequency and the load capacitance on every output pin. The maximum DRVDD current occurs when each output bit toggles between 0 and 1 every clock cycle. In actual applications, this condition is unlikely to occur. The actual DRVDD current would be determined by the average number of output bits switching, which is a function of the sampling frequency and the nature of the analog input signal.

$$\text{Digital current due to CMOS output switching} = C_L \times \text{DRVDD} \times (N \times F_{\text{AVG}}),$$

where C_L = load capacitance, $N \times F_{\text{AVG}}$ = average number of output bits switching.

Figure 30 shows the current with various load capacitances across sampling frequencies at 2 MHz analog input frequency.

DDR LVDS Interface

The LVDS interface works only with 3.3V DRVDD supply. In this mode, the 11 data bits of each channel and a common output clock are available as LVDS (Low Voltage Differential Signal) levels. Two successive data bits are multiplexed and output on each LVDS differential pair every clock cycle (DDR – Double Data Rate, Figure 45).

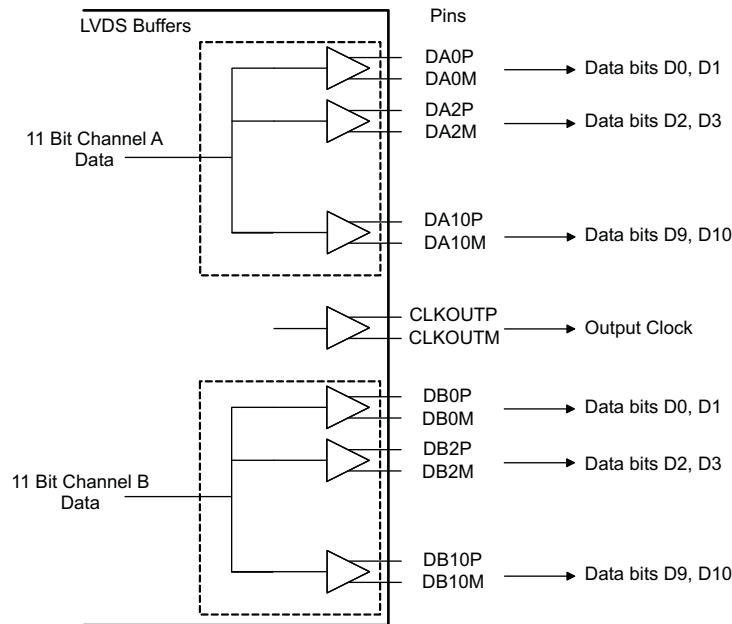

Figure 44. DDR LVDS Outputs

Odd data bits D1, D3, D5, D7, D9 are output at the rising edge of CLKOUTP and even data bits D0, D2, D4, D6, D8, D10 are output at the falling edge of CLKOUTP. Both the rising and falling edges of CLKOUTP have to be used to capture all the data bits.

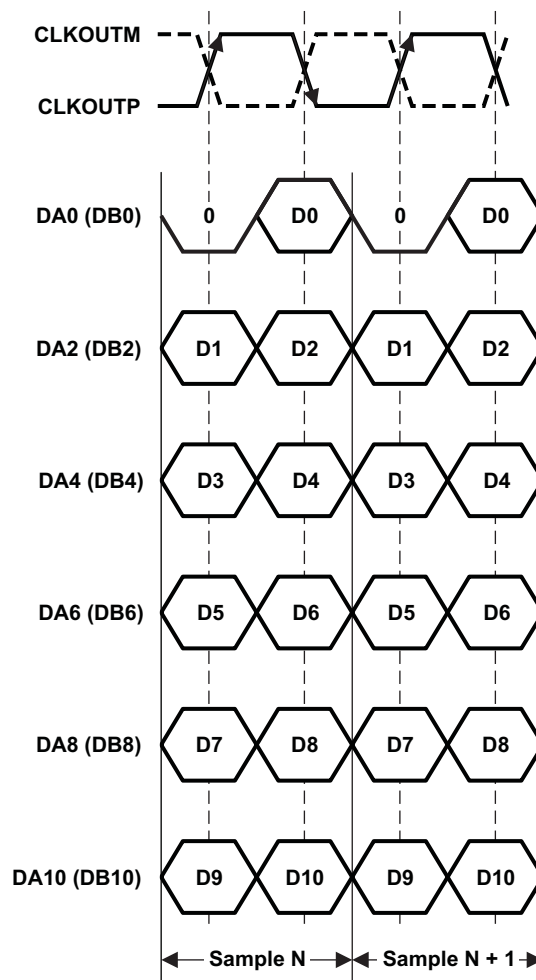

Figure 45. DDR LVDS Interface

LVDS Buffer Current Programmability

The default LVDS buffer output current is 3.5 mA. When terminated by 100 Ω , this results in a 350-mV single-ended voltage swing (700-mV_{PP} differential swing). The LVDS buffer currents can also be programmed to 2.5 mA, 4.5 mA, and 1.75 mA ([LVDS CURRENT](#)). In addition, there exists a current double mode, where this current is doubled for the data and output clock buffers (register bits [CURRENT DOUBLE](#)).

LVDS Buffer Internal Termination

An internal termination option is available (using the serial interface), by which the LVDS buffers are differentially terminated inside the device. The termination resistances available are –300 Ω , 185 Ω , and 150 Ω (nominal with $\pm 20\%$ variation). Any combination of these three terminations can be programmed; the effective termination is the parallel combination of the selected resistances. This results in eight effective terminations from open (no termination) to 60 Ω .

The internal termination helps to absorb any reflections coming from the receiver end, improving the signal integrity. With 100 Ω internal and 100 Ω external termination, the voltage swing at the receiver end is halved (compared to no internal termination). The voltage swing can be restored by using the LVDS current double mode. [Figure 46](#) and [Figure 47](#) compare the LVDS eye diagrams without and with 100 Ω internal termination. With internal termination, the eye looks clean even with 10 pF load capacitance (from each output pin to ground). The terminations can be programmed using register bits ([LVDS TERMINATION](#)).

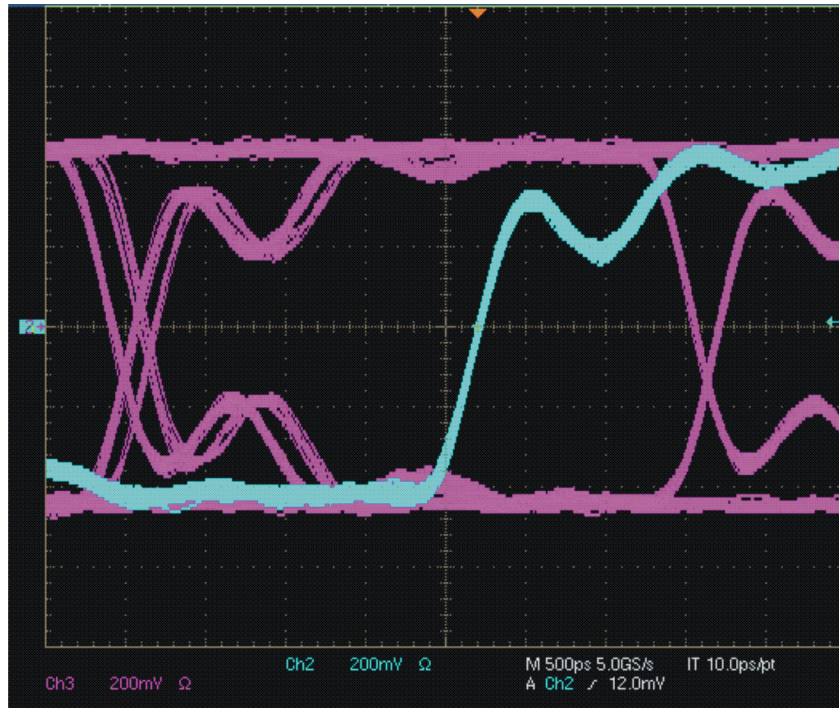

Figure 46. LVDS Eye Diagram – No Internal Termination, External Termination = 100 Ω

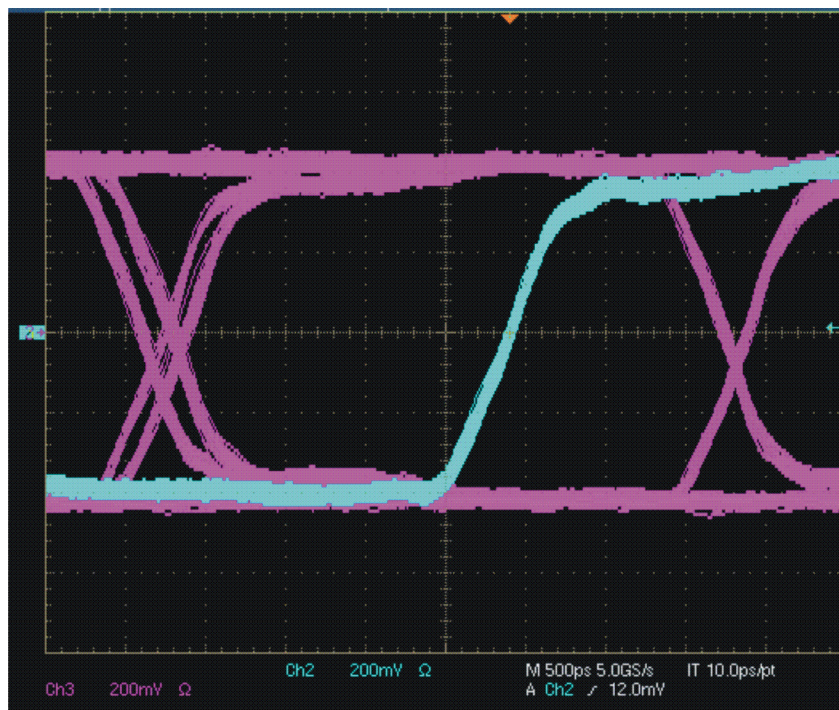

Figure 47. LVDS Eye Diagram – With 100Ω Internal Termination, External termination = 100 Ω and LVDS current double mode enabled

Output Data Format

Two output data formats are supported – 2s complement and straight binary. They can be selected using the serial interface register bit **<DATA FORMAT>** or controlling the SEN pin in parallel configuration mode.

In the event of an input voltage overdrive, the digital outputs go to the appropriate full scale level. For a positive overdrive, the output code is 0x7FF in offset binary output format, and 0x3FF in 2s complement output format. For a negative input overdrive, the output code is 0x000 in offset binary output format and 0x400 in 2s complement output format.

Multiplexed Output mode

This mode is available only with CMOS interface. In this mode, the digital outputs of both the channels are multiplexed and output on a single bus (DB0-DB10 pins), as per the timing diagram shown in Figure 48. The channel A output pins (DA0-DA10) are tri-stated. Since the output data rate on the DB bus is effectively doubled, this mode is recommended only for low sampling frequencies (<65 MSPS).

This mode can be enabled using register bits **<POWER DOWN MODES>** or using the parallel pins CTRL1 -3 ().

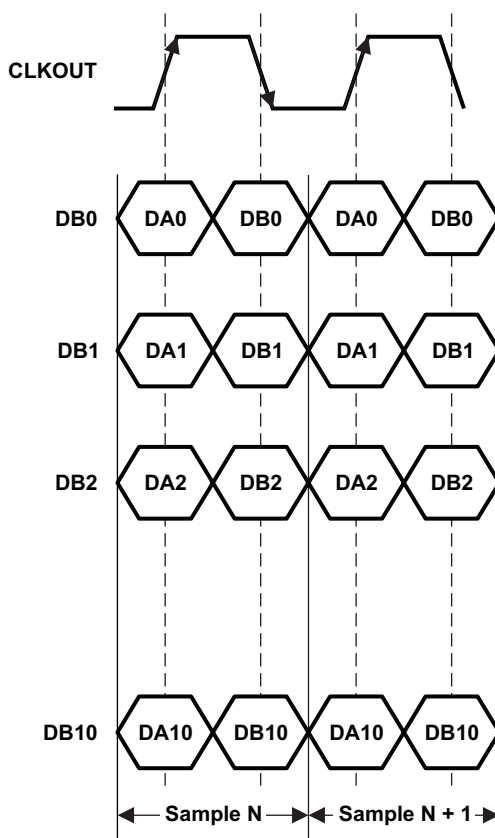

Figure 48. Multiplexed mode – Output Timing

Low Latency Mode

The default latency of ADS62P15 is 14 clock cycles. For applications, which cannot tolerate large latency, ADS62P15 includes a special mode with 10 clock cycles latency. In the low latency condition, the Digital Processing block is bypassed and its features (offset correction, fine gain, decimation filters) are not available.

DETAILS OF DIGITAL PROCESSING BLOCK

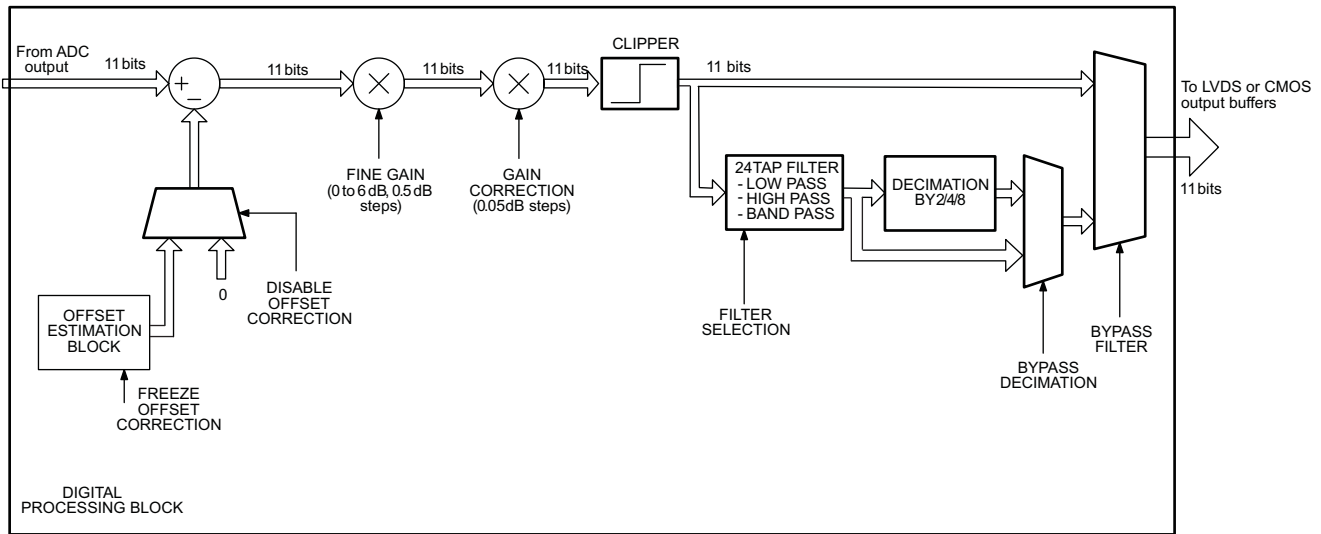

Figure 49. Digital Processing Block Diagram

Offset Correction

ADS62P15 has an internal offset correction algorithm that estimates and corrects dc offset up to $\pm 10\text{mV}$. The correction can be enabled using the serial register bit ([OFFSET LOOP EN](#)). Once enabled, the algorithm estimates the channel offset and applies the correction every clock cycle. The time constant of the correction loop is a function of the sampling clock frequency. The time constant can be controlled using register bits ([OFFSET LOOP TC](#)) as described in [Table 22](#).

Table 22. Time Constant of Offset Correction Algorithm

| <OFFSET LOOP TC> D6-D5-D4 | Time constant (TC_{CLK}), number of clock cycles | Time constant, sec ($=TC_{CLK} \times 1/F_s$) ⁽¹⁾ |
|------------------------------|---|---|
| 000 | 2^{27} | 1.1 |
| 001 | 2^{26} | 0.55 |
| 010 | 2^{25} | 0.27 |
| 011 | 2^{24} | 0.13 |
| 100 | 2^{28} | 2.15 |
| 101 | 2^{29} | 4.3 |
| 110 | 2^{27} | 1.1 |
| 111 | 2^{27} | 1.1 |

(1) Sampling frequency, $F_s = 125 \text{ MSPS}$

It is also possible to freeze the offset correction using the serial interface (<OFFSET LOOP FREEZE>). Once frozen, the offset estimation becomes inactive and the last estimated value is used for correction every clock cycle. Note that the offset correction is disabled by default after reset.

Figure 50 shows the time response of the offset correction algorithm, after it is enabled.

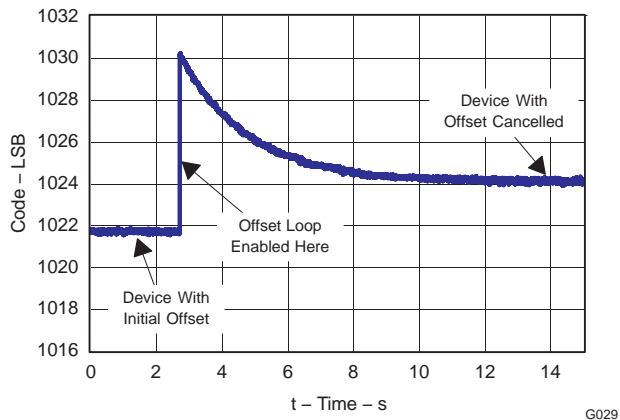

Figure 50. Time Response of Offset Correction

Gain Correction

ADS62P15 has ability to make fine corrections to the ADC channel gain. The corrections can be done in steps of 0.05 dB, up to a maximum of 0.5 dB, using the register bits ([GAIN CORRECTION](#)). Only positive corrections are supported and the same correction applies to both the channels.

Table 23. Gain Correction Values

| <GAIN CORRECTION> D3-D2-D1-D0 | Amount of correction, dB |
|----------------------------------|-----------------------------|
| 0000 | 0 |
| 0001 | +0.05 |
| 0010 | +0.1 |
| 0011 | +0.15 |
| 0100 | +0.20 |
| 0101 | +0.25 |
| 0110 | +0.30 |
| 0111 | +0.35 |
| 1000 | +0.40 |
| 1001 | +0.45 |
| 1010 | +0.5 |
| Other combinations | Unused |

Decimation Filters

ADS62P15 includes option to decimate the ADC output data with in-built low pass, high pass or band pass filters. The decimation rate and type of filter can be selected using register bits ([DECIMATION RATE](#)) and ([DECIMATION FILTER TYPE](#)). Decimation rates of 2, 4 or 8 are available and either low pass, high pass or band pass filters can be selected (see [Table 24](#)). By default, the decimation filter is disabled – use register bit [<DECIMATION ENABLE>](#) to enable it.

Table 24. Decimation Filter Modes

| COMBINATION OF DECIMATION RATES AND FILTER TYPES | | <DECIMATION RATE> | | | <DECIMATION FILTER FREQ BAND> | | <FILTER COEFF SELECT > | <DECIMATION ENABLE> |
|--|---|-------------------|---|---|-------------------------------|---|------------------------|---------------------|
| DECIMATION | TYPE OF FILTER | | | | | | | |
| Decimate by 2 | In-built low pass filter (pass band = 0 to Fs/4) | 0 | 0 | 0 | 0 | 0 | 0 | 1 |
| | In-built high pass filter (pass band = Fs/4 to Fs/2) | 0 | 0 | 0 | 0 | 1 | 0 | 1 |
| Decimate by 4 | In-built low pass filter (pass band = 0 to Fs/8) | 0 | 0 | 1 | 0 | 0 | 0 | 1 |
| | In-built 2 nd band pass filter (pass band = Fs/8 to Fs/4) | 0 | 0 | 1 | 0 | 1 | 0 | 1 |
| | In-built 3 rd band pass filter (pass band = Fs/4 to 3Fs/8) | 0 | 0 | 1 | 1 | 0 | 0 | 1 |
| | In-built last band pass filter (pass band = 3Fs/8 to Fs/2) | 0 | 0 | 1 | 1 | 1 | 0 | 1 |
| Decimate by 2 | Custom filter (user programmable coefficients) | 0 | 0 | 0 | X | X | 1 | 1 |
| Decimate by 4 | Custom filter (user programmable coefficients) | 0 | 0 | 1 | X | X | 1 | 1 |
| Decimate by 8 | Custom filter (user programmable coefficients) | 1 | 0 | 0 | X | X | 1 | 1 |
| No decimation | Custom filter (user programmable coefficients) | 0 | 1 | 1 | X | X | 1 | 0 |

Decimation Filter Equation

The decimation filter is implemented as 24-tap FIR with symmetrical coefficients (each coefficient is 12-bit signed). The filter equation is:

$$y(n) = \left(\frac{1}{2^{11}}\right) \times [h_0 \times x(n) + h_1 \times x(n - 1) + h_2 \times x(n - 2) + \dots + h_{11} \times x(n - 11) + h_{11} \times x(n - 12) + \dots + h_1 \times x(n - 22) + h_0 \times x(n - 23)] \tag{3}$$

By setting the register bit [<ODD TAP ENABLE>](#) = 1, a 23-tap FIR is implemented:

$$y(n) = \left(\frac{1}{2^{11}}\right) \times [h_0 \times x(n) + h_1 \times x(n - 1) + h_2 \times x(n - 2) + \dots + h_{10} \times x(n - 10) + h_{11} \times x(n - 11) + h_{10} \times x(n - 12) + \dots + h_1 \times x(n - 21) + h_0 \times x(n - 22)] \tag{4}$$

In the above equations,

- h0, h1 ...h11 are 12-bit signed representation of the coefficients,
- x(n) is the input data sequence to the filter
- y(n) is the filter output sequence

Pre-defined Coefficients

The in-built filter types (low pass, high pass and band pass) use pre-defined coefficients. The frequency response of the in-built filters is shown in [Figure 51](#) and [Figure 52](#).

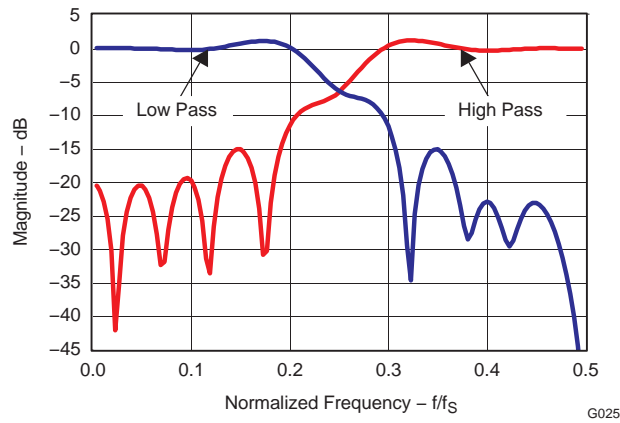

Figure 51. Decimate by 2 Filter Response

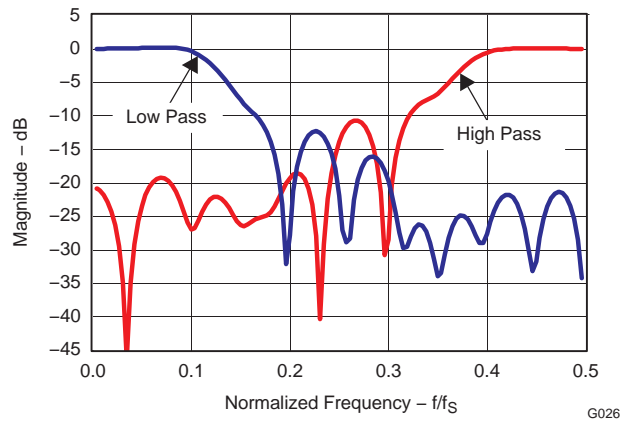

Figure 52. Decimate by 4 Filter Response

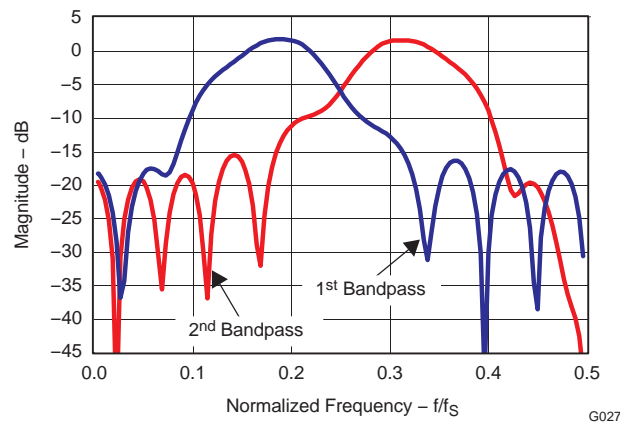

Figure 53. Decimate by 4 Bandpass Response

Table 25. Predefined Coefficients for Decimation by 2 Filters

| COEFFICIENTS | DECIMATE BY 2 | |
|--------------|-----------------|------------------|
| | LOW PASS FILTER | HIGH PASS FILTER |
| h0 | 23 | -22 |
| h1 | -37 | -65 |
| h2 | -6 | -52 |
| h3 | 68 | 30 |
| h4 | -36 | 66 |
| h5 | -61 | -35 |
| h6 | 35 | -107 |
| h7 | 118 | 38 |
| h8 | -100 | 202 |
| h9 | -197 | -41 |
| h10 | 273 | -644 |
| h11 | 943 | 1061 |

Table 26. Predefined Coefficients for Decimation by 4 Filters

| COEFFICIENTS | DECIMATE BY 4 | | | |
|--------------|-----------------|----------------------|----------------------|------------------|
| | LOW PASS FILTER | 1st BAND PASS FILTER | 2ND BAND PASS FILTER | HIGH PASS FILTER |
| h0 | -17 | -7 | -34 | 32 |
| h1 | -50 | 19 | -34 | -15 |
| h2 | 71 | -47 | -101 | -95 |
| h3 | 46 | 127 | 43 | 22 |
| h4 | 24 | 73 | 58 | -8 |
| h5 | -42 | 0 | -28 | -81 |
| h6 | -100 | 86 | -5 | 106 |
| h7 | -97 | 117 | -179 | -62 |
| h8 | 8 | -190 | 294 | -97 |
| h9 | 202 | -464 | 86 | 310 |
| h10 | 414 | -113 | -563 | -501 |
| h11 | 554 | 526 | 352 | 575 |

Custom Filter Coefficients with Decimation

The filter coefficients can also be programmed by the user (custom). For custom coefficients, set the register bit ([FILTER COEFF SELECT](#)) and load the coefficients (h0 to h11) in registers 1E to 2F using the serial interface ([Table 27](#)) as:

$$\text{Register content} = 12 \text{ bit signed representation of } [\text{real coefficient value} \times 2^{11}]$$

Custom Filter Coefficients without Decimation

The filter with custom coefficients can also be used with the decimation mode disabled. In this mode, the filter implementation is 12-tap FIR:

 $y(n) =$

$$\left(\frac{1}{2^{11}}\right) \times [h_6 \times x(n) + h_7 \times x(n-1) + h_8 \times x(n-2) + \dots + h_{11} \times x(n-5) + h_{11} \times x(n-6) + \dots + h_7 \times x(n-10) + h_6 \times x(n-11)] \quad (5)$$

Table 27. Register Map of Custom Coefficients

| A7-A0 (hex) | D7 | D6 | D5 | D4 | D3 | D2 | D1 | D0 |
|----------------|------------------------|----|----|----|------------------------|----|----|----|
| 1E | Coefficient h0 <7:0> | | | | | | | |
| 1F | Coefficient h1 <3:0> | | | | Coefficient h0 <11:8> | | | |
| 20 | Coefficient h1 <11:4> | | | | | | | |
| 21 | Coefficient h2 <7:0> | | | | | | | |
| 22 | Coefficient h3 <3:0> | | | | Coefficient h2 <11:8> | | | |
| 23 | Coefficient h3 <11:4> | | | | | | | |
| 24 | Coefficient h4 <7:0> | | | | | | | |
| 25 | Coefficient h5 <3:0> | | | | Coefficient h4 <11:8> | | | |
| 26 | Coefficient h5 <11:4> | | | | | | | |
| 27 | Coefficient h6 <7:0> | | | | | | | |
| 28 | Coefficient h7 <3:0> | | | | Coefficient h6 <11:8> | | | |
| 29 | Coefficient h7 <11:4> | | | | | | | |
| 2A | Coefficient h8 <7:0> | | | | | | | |
| 2B | Coefficient h9 <3:0> | | | | Coefficient h8 <11:8> | | | |
| 2C | Coefficient h9 <11:4> | | | | | | | |
| 2D | Coefficient h10 <7:0> | | | | | | | |
| 2E | Coefficient h11 <3:0> | | | | Coefficient h10 <11:8> | | | |
| 2F | Coefficient h11 <11:4> | | | | | | | |

BOARD DESIGN CONSIDERATIONS

Grounding

A single ground plane is sufficient to give good performance, provided the analog, digital, and clock sections of the board are cleanly partitioned. See the EVM User Guide ([SLAU237](#)) for details on layout and grounding.

Supply Decoupling

As the ADS62P15 already includes internal decoupling, minimal external decoupling can be used without loss in performance. Note that decoupling capacitors can help filter external power supply noise, so the optimum number of capacitors would depend on the actual application. The decoupling capacitors should be placed very close to the converter supply pins.

It is recommended to use separate supplies for the analog and digital supply pins to isolate digital switching noise from sensitive analog circuitry. In case only a single 3.3-V supply is available, it should be routed first to AVDD. It can then be tapped and isolated with a ferrite bead (or inductor) with decoupling capacitor, before being routed to DRVDD.

Exposed Thermal Pad

It is necessary to solder the exposed pad at the bottom of the package to a ground plane for best thermal performance. For detailed information, see application notes ***QFN Layout Guidelines*** ([SLOA122](#)) and ***QFN/SON PCB Attachment*** ([SLUA271](#)).

DEFINITION OF SPECIFICATIONS

Analog Bandwidth – The analog input frequency at which the power of the fundamental is reduced by 3 dB with respect to the low frequency value.

Aperture Delay – The delay in time between the rising edge of the input sampling clock and the actual time at which the sampling occurs. This delay will be different across channels. The maximum variation is specified as aperture delay variation (channel-channel).

Aperture Uncertainty (Jitter) – The sample-to-sample variation in aperture delay.

Clock Pulse Width/Duty Cycle – The duty cycle of a clock signal is the ratio of the time the clock signal remains at a logic high (clock pulse width) to the period of the clock signal. Duty cycle is typically expressed as a percentage. A perfect differential sine-wave clock results in a 50% duty cycle.

Maximum Conversion Rate – The maximum sampling rate at which certified operation is given. All parametric testing is performed at this sampling rate unless otherwise noted.

Minimum Conversion Rate – The minimum sampling rate at which the ADC functions.

Differential Nonlinearity (DNL) – An ideal ADC exhibits code transitions at analog input values spaced exactly 1 LSB apart. The DNL is the deviation of any single step from this ideal value, measured in units of LSBs.

Integral Nonlinearity (INL) – The INL is the deviation of the ADC's transfer function from a best fit line determined by a least squares curve fit of that transfer function, measured in units of LSBs.

Gain Error – The gain error is the deviation of the ADC's actual input full-scale range from its ideal value. The gain error is given as a percentage of the ideal input full-scale range. The gain error does not include the error caused by the internal reference deviation from ideal value. This is specified separately as internal reference error. The maximum variation of the gain error across devices and across channels within a device is specified separately.

Offset Error – The offset error is the difference, given in number of LSBs, between the ADC's actual average idle channel output code and the ideal average idle channel output code. This quantity is often mapped into mV.

Temperature Drift – The temperature drift coefficient (with respect to gain error and offset error) specifies the change per degree Celsius of the parameter from T_{MIN} to T_{MAX} . It is calculated by dividing the maximum deviation of the parameter across the T_{MIN} to T_{MAX} range by the difference $T_{MAX}-T_{MIN}$.

Signal-to-Noise Ratio – SNR is the ratio of the power of the fundamental (P_S) to the noise floor power (P_N), excluding the power at DC and the first nine harmonics.

$$SNR = 10\text{Log}_{10} \frac{P_S}{P_N} \quad (6)$$

SNR is either given in units of dBc (dB to carrier) when the absolute power of the fundamental is used as the reference, or dBFS (dB to full scale) when the power of the fundamental is extrapolated to the converter's full-scale range.

Signal-to-Noise and Distortion (SINAD) – SINAD is the ratio of the power of the fundamental (P_S) to the power of all the other spectral components including noise (P_N) and distortion (P_D), but excluding dc.

$$SINAD = 10\text{Log}_{10} \frac{P_S}{P_N + P_D} \quad (7)$$

SINAD is either given in units of dBc (dB to carrier) when the absolute power of the fundamental is used as the reference, or dBFS (dB to full scale) when the power of the fundamental is extrapolated to the converter's full-scale range.

Effective Number of Bits (ENOB) – The ENOB is a measure of a converter's performance as compared to the theoretical limit based on quantization noise.

$$ENOB = \frac{SINAD - 1.76}{6.02} \quad (8)$$

Total Harmonic Distortion (THD) – THD is the ratio of the power of the fundamental (P_S) to the power of the first nine harmonics (P_D).

$$\text{THD} = 10\text{Log}_{10} \frac{P_s}{P_D} \quad (9)$$

THD is typically given in units of dBc (dB to carrier).

Spurious-Free Dynamic Range (SFDR) – The ratio of the power of the fundamental to the highest other spectral component (either spur or harmonic). SFDR is typically given in units of dBc (dB to carrier).

Two-Tone Intermodulation Distortion – IMD3 is the ratio of the power of the fundamental (at frequencies f_1 and f_2) to the power of the worst spectral component at either frequency $2f_1 - f_2$ or $2f_2 - f_1$. IMD3 is either given in units of dBc (dB to carrier) when the absolute power of the fundamental is used as the reference, or dBFS (dB to full scale) when the power of the fundamental is extrapolated to the converter's full-scale range.

DC Power Supply Rejection Ratio (DC PSRR) – The DC PSRR is the ratio of the change in offset error to a change in analog supply voltage. The DC PSRR is typically given in units of mV/V.

AC Power Supply Rejection Ratio (AC PSRR) – AC PSRR is the measure of rejection of variations in the supply voltage by the ADC. If ΔV_{sup} is the change in supply voltage and ΔV_{out} is the resultant change of the ADC output code (referred to the input), then

$$\text{PSRR} = 20\text{Log}_{10} \frac{\Delta V_{\text{out}}}{\Delta V_{\text{sup}}}, \text{ expressed in dBc} \quad (10)$$

Voltage Overload Recovery – The number of clock cycles taken to recover to less than 1% error after an overload on the analog inputs. This is tested by separately applying a sine wave signal with 6dB positive and negative overload. The deviation of the first few samples after the overload (from their expected values) is noted.

Common Mode Rejection Ratio (CMRR) – CMRR is the measure of rejection of variation in the analog input common-mode by the ADC. If $\Delta V_{\text{cm_in}}$ is the change in the common-mode voltage of the input pins and ΔV_{out} is the resultant change of the ADC output code (referred to the input), then

$$\text{CMRR} = 20\text{Log}_{10} \frac{\Delta V_{\text{out}}}{\Delta V_{\text{cm_in}}}, \text{ expressed in dBc} \quad (11)$$

Cross-Talk (only for multi-channel ADC)– This is a measure of the internal coupling of a signal from adjacent channel into the channel of interest. It is specified separately for coupling from the immediate neighbouring channel (near-channel) and for coupling from channel across the package (far-channel). It is usually measured by applying a full-scale signal in the adjacent channel. Cross-talk is the ratio of the power of the coupling signal (as measured at the output of the channel of interest) to the power of the signal applied at the adjacent channel input. It is typically expressed in dBc.

REVISION HISTORY

| Changes from Revision A (February 2008) to Revision B | Page |
|---|------|
| • Added Aperture delay matching to TIMING REQUIREMENTS – LVDS AND CMOS MODES | 9 |
| • Added t_{START} description to TIMING REQUIREMENTS – LVDS AND CMOS MODES | 10 |
| • Added t_{DV} description to TIMING REQUIREMENTS – LVDS AND CMOS MODES | 10 |
| • Added t_{START_CHA} description to TIMING REQUIREMENTS – LVDS AND CMOS MODES | 10 |
| • Added t_{DV_CHA} description to TIMING REQUIREMENTS – LVDS AND CMOS MODES | 10 |
| • Added t_{START_CHB} description to TIMING REQUIREMENTS – LVDS AND CMOS MODES | 10 |
| • Added t_{DV_CHB} description to TIMING REQUIREMENTS – LVDS AND CMOS MODES | 10 |
| • Added t_{START_CHA} description to TIMING REQUIREMENTS – LVDS AND CMOS MODES | 10 |
| • Added t_{DV_CHA} description to TIMING REQUIREMENTS – LVDS AND CMOS MODES | 10 |
| • Added t_{START_CHB} description to TIMING REQUIREMENTS – LVDS AND CMOS MODES | 10 |
| • Added t_{DV_CHB} description to TIMING REQUIREMENTS – LVDS AND CMOS MODES | 10 |
| • Changed Figure 4 CMOS Mode Timing | 13 |
| • Added Figure 5 Multiplexed Mode Timing (CMOS only) | 13 |
| • Added text to USING PARALLEL INTERFACE CONTROL ONLY section description | 14 |
| • Added voltage values to Table 4 | 15 |
| • Added voltage values to Table 5 | 15 |
| • Changed Channel A and B powered down to Power down global in Table 6 | 15 |
| • Deleted only with CMOS interface from Table 6 | 15 |
| • Added Serial Register Readout section | 18 |
| • Added SERIAL READOUT to register address 00 in Table 7 | 20 |
| • Added SERIAL READOUT to register address 00 description | 21 |
| • Changed register address 14, bits D2-D0 111 description from DA10 to DA0 pins to DB10 to DB0 pins. | 23 |
| • Changed pin 56 from NC to SDOUT in CMOS interface pinout | 27 |
| • Changed pin 56 from NC to SDOUT and added SDOUT description in Pin Assignments (CMOS INTERFACE) | 28 |
| • Changed Channel A and B powered down to Global power down in Table 21 | 42 |
| Changes from Revision B (April 2009) to Revision C | |
| • Changed 29, 30 and 19, 20 in CMOS interface pinout | 27 |
| • Changed pins 29, 30 in Pin Assignments (CMOS INTERFACE) | 28 |
| • Changed pins 19, 20 in Pin Assignments (CMOS INTERFACE) | 28 |
| • Changed 29, 30 and 19, 20 in LVDS interface pinout | 29 |
| • Changed pins 29,30 in Pin Assignments (LVDS INTERFACE) | 29 |
| • Changed pins 19,20 in Pin Assignments (LVDS INTERFACE) | 29 |

PACKAGING INFORMATION

| Orderable Device | Status (1) | Package Type | Package Drawing | Pins | Package Qty | Eco Plan (2) | Lead/Ball Finish (6) | MSL Peak Temp (3) | Op Temp (°C) | Device Marking (4/5) | Samples |
|------------------|---------------|--------------|--------------------|------|----------------|----------------------------|-------------------------|----------------------|--------------|-------------------------|---------|
| ADS62P15IRGCT | ACTIVE | VQFN | RGC | 64 | 250 | Green (RoHS & no Sb/Br) | CU NIPDAU | Level-3-260C-168 HR | -40 to 85 | AZ62P15 | Samples |

(1) The marketing status values are defined as follows:

ACTIVE: Product device recommended for new designs.

LIFEBUY: TI has announced that the device will be discontinued, and a lifetime-buy period is in effect.

NRND: Not recommended for new designs. Device is in production to support existing customers, but TI does not recommend using this part in a new design.

PREVIEW: Device has been announced but is not in production. Samples may or may not be available.

OBSOLETE: TI has discontinued the production of the device.

(2) **RoHS:** TI defines "RoHS" to mean semiconductor products that are compliant with the current EU RoHS requirements for all 10 RoHS substances, including the requirement that RoHS substance do not exceed 0.1% by weight in homogeneous materials. Where designed to be soldered at high temperatures, "RoHS" products are suitable for use in specified lead-free processes. TI may reference these types of products as "Pb-Free".

RoHS Exempt: TI defines "RoHS Exempt" to mean products that contain lead but are compliant with EU RoHS pursuant to a specific EU RoHS exemption.

Green: TI defines "Green" to mean the content of Chlorine (Cl) and Bromine (Br) based flame retardants meet JS709B low halogen requirements of <=1000ppm threshold. Antimony trioxide based flame retardants must also meet the <=1000ppm threshold requirement.

(3) MSL, Peak Temp. - The Moisture Sensitivity Level rating according to the JEDEC industry standard classifications, and peak solder temperature.

(4) There may be additional marking, which relates to the logo, the lot trace code information, or the environmental category on the device.

(5) Multiple Device Markings will be inside parentheses. Only one Device Marking contained in parentheses and separated by a "~" will appear on a device. If a line is indented then it is a continuation of the previous line and the two combined represent the entire Device Marking for that device.

(6) Lead/Ball Finish - Orderable Devices may have multiple material finish options. Finish options are separated by a vertical ruled line. Lead/Ball Finish values may wrap to two lines if the finish value exceeds the maximum column width.

Important Information and Disclaimer: The information provided on this page represents TI's knowledge and belief as of the date that it is provided. TI bases its knowledge and belief on information provided by third parties, and makes no representation or warranty as to the accuracy of such information. Efforts are underway to better integrate information from third parties. TI has taken and continues to take reasonable steps to provide representative and accurate information but may not have conducted destructive testing or chemical analysis on incoming materials and chemicals. TI and TI suppliers consider certain information to be proprietary, and thus CAS numbers and other limited information may not be available for release.

In no event shall TI's liability arising out of such information exceed the total purchase price of the TI part(s) at issue in this document sold by TI to Customer on an annual basis.

TAPE AND REEL INFORMATION



QUADRANT ASSIGNMENTS FOR PIN 1 ORIENTATION IN TAPE

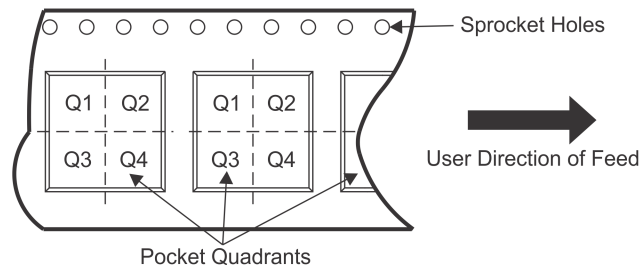

*All dimensions are nominal

| Device | Package Type | Package Drawing | Pins | SPQ | Reel Diameter (mm) | Reel Width W1 (mm) | A0 (mm) | B0 (mm) | K0 (mm) | P1 (mm) | W (mm) | Pin1 Quadrant |
|---------------|--------------|-----------------|------|-----|--------------------|--------------------|---------|---------|---------|---------|--------|---------------|
| ADS62P15IRGCT | VQFN | RGC | 64 | 250 | 180.0 | 16.4 | 9.3 | 9.3 | 1.5 | 12.0 | 16.0 | Q2 |

TAPE AND REEL BOX DIMENSIONS

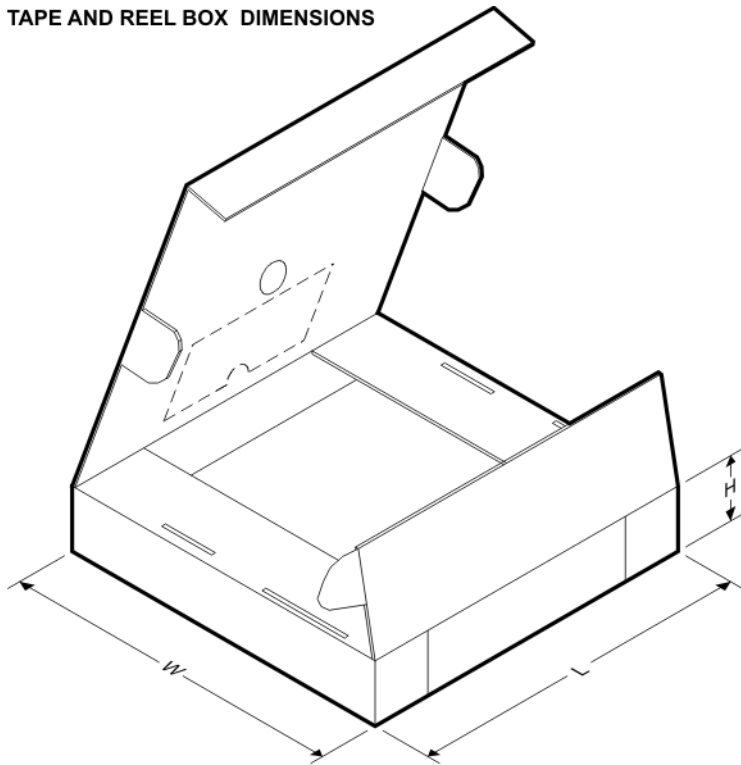

*All dimensions are nominal

| Device | Package Type | Package Drawing | Pins | SPQ | Length (mm) | Width (mm) | Height (mm) |
|---------------|--------------|-----------------|------|-----|-------------|------------|-------------|
| ADS62P15IRGCT | VQFN | RGC | 64 | 250 | 213.0 | 191.0 | 55.0 |

GENERIC PACKAGE VIEW

RGC 64

VQFN - 1 mm max height

9 x 9, 0.5 mm pitch

PLASTIC QUAD FLATPACK - NO LEAD

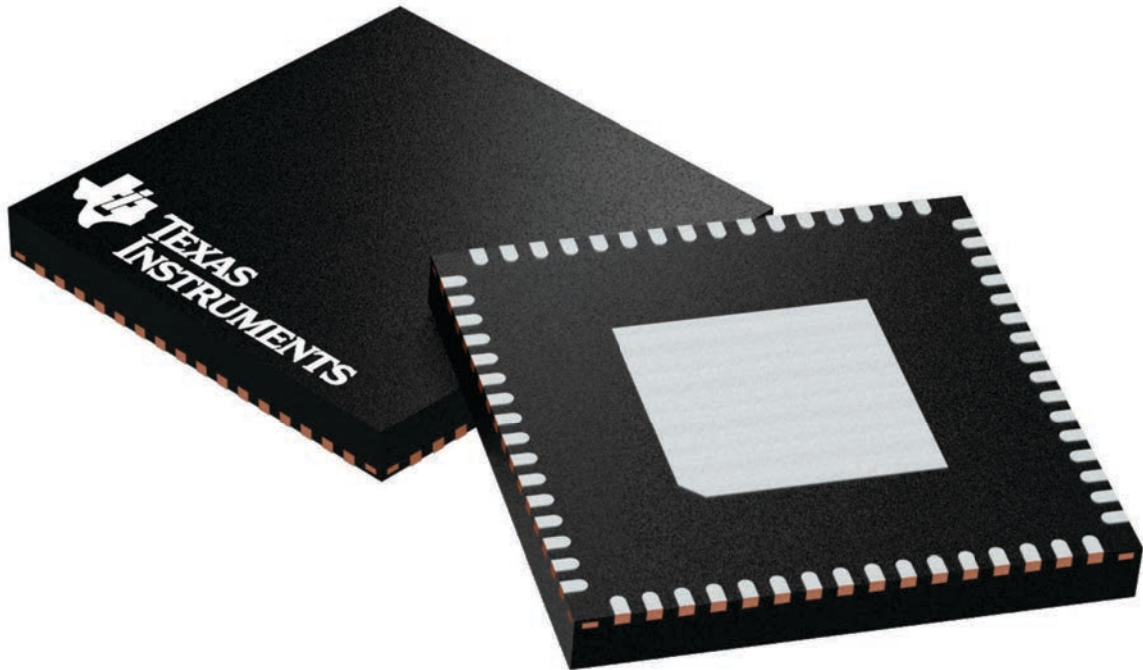

Images above are just a representation of the package family, actual package may vary.
Refer to the product data sheet for package details.

4224597/A

EXAMPLE BOARD LAYOUT

RGC0064H

VQFN - 1 mm max height

PLASTIC QUAD FLATPACK - NO LEAD

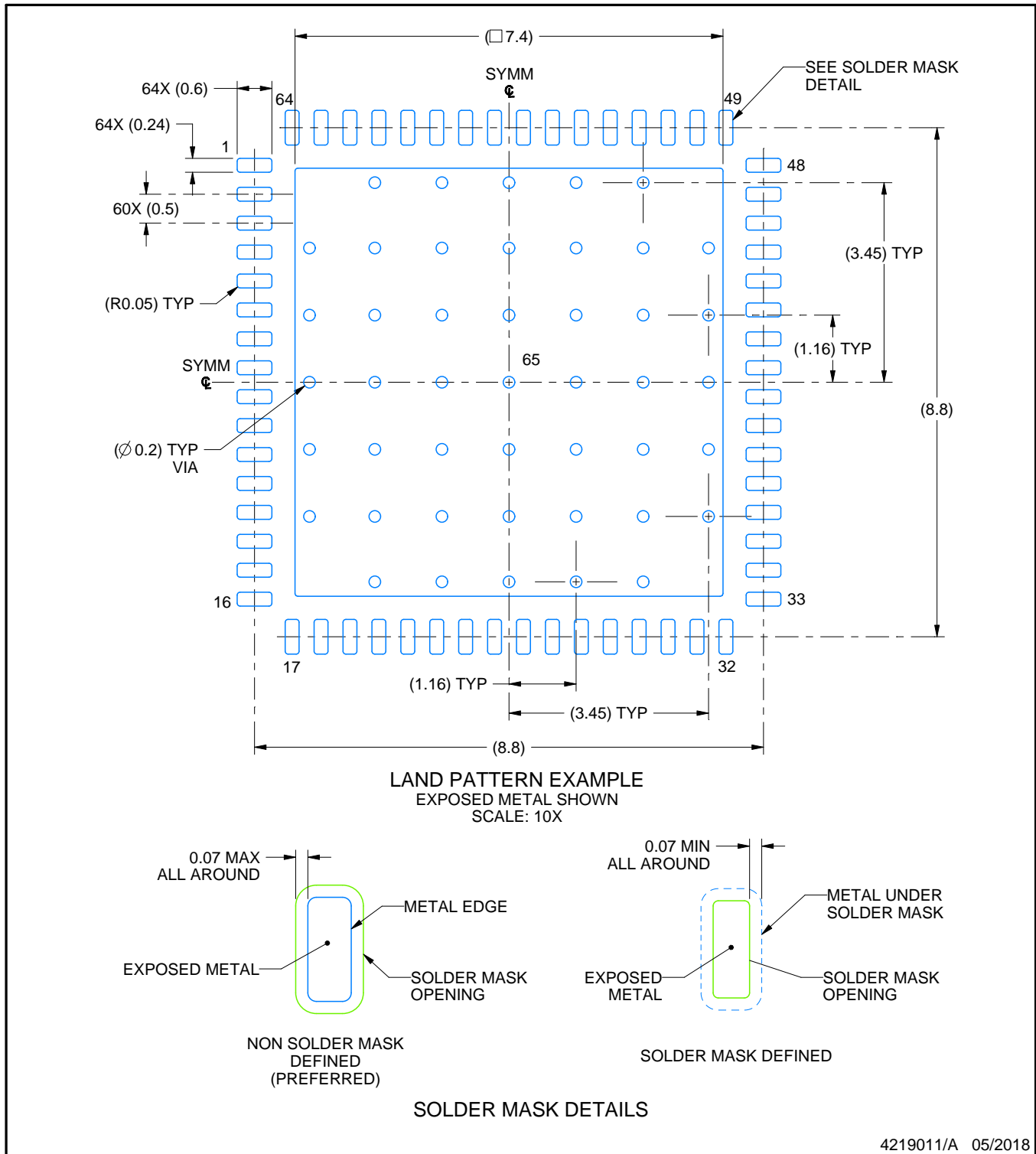

4219011/A 05/2018

NOTES: (continued)

4. This package is designed to be soldered to a thermal pad on the board. For more information, see Texas Instruments literature number SLUA271 (www.ti.com/lit/sluea271).
5. Vias are optional depending on application, refer to device data sheet. If any vias are implemented, refer to their locations shown on this view. It is recommended that vias under paste be filled, plugged or tented.

EXAMPLE STENCIL DESIGN

RGC0064H

VQFN - 1 mm max height

PLASTIC QUAD FLATPACK - NO LEAD

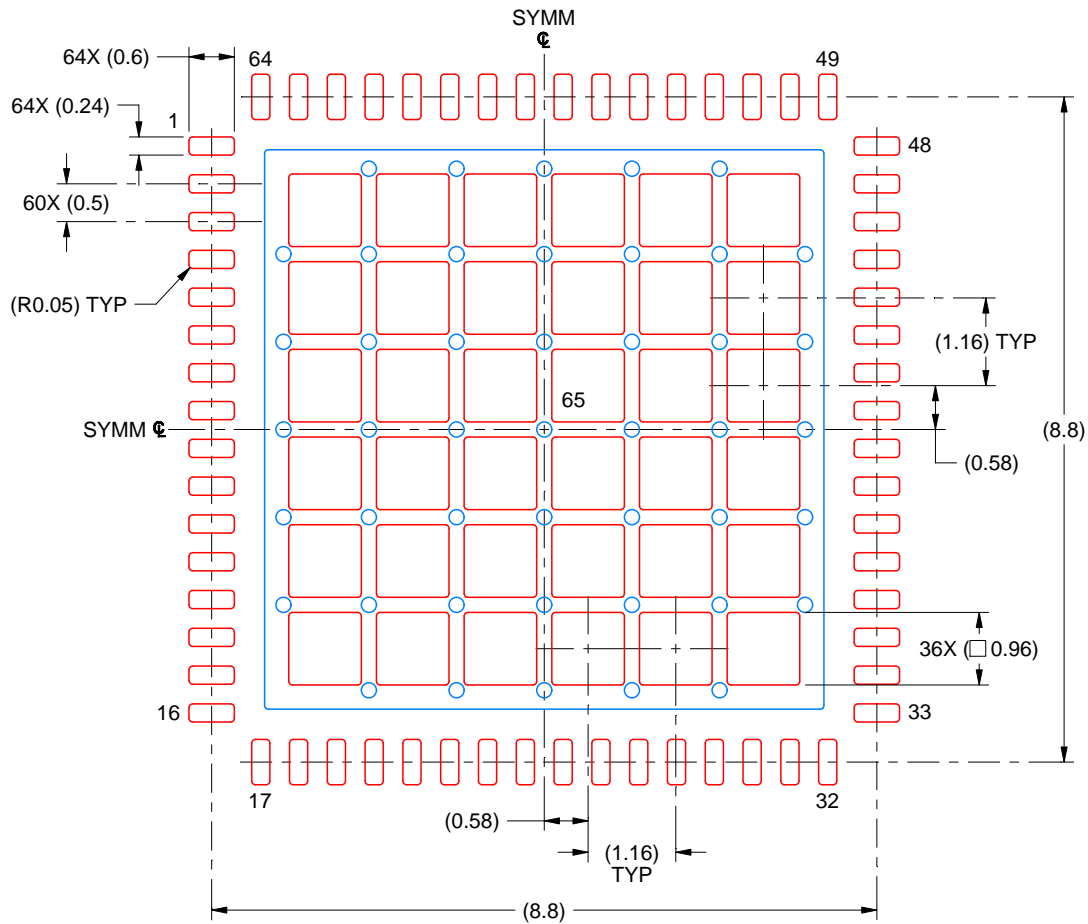

SOLDER PASTE EXAMPLE
 BASED ON 0.125 MM THICK STENCIL
 SCALE: 10X

EXPOSED PAD 65
 61% PRINTED SOLDER COVERAGE BY AREA UNDER PACKAGE

4219011/A 05/2018

NOTES: (continued)

6. Laser cutting apertures with trapezoidal walls and rounded corners may offer better paste release. IPC-7525 may have alternate design recommendations.

IMPORTANT NOTICE AND DISCLAIMER

TI PROVIDES TECHNICAL AND RELIABILITY DATA (INCLUDING DATASHEETS), DESIGN RESOURCES (INCLUDING REFERENCE DESIGNS), APPLICATION OR OTHER DESIGN ADVICE, WEB TOOLS, SAFETY INFORMATION, AND OTHER RESOURCES "AS IS" AND WITH ALL FAULTS, AND DISCLAIMS ALL WARRANTIES, EXPRESS AND IMPLIED, INCLUDING WITHOUT LIMITATION ANY IMPLIED WARRANTIES OF MERCHANTABILITY, FITNESS FOR A PARTICULAR PURPOSE OR NON-INFRINGEMENT OF THIRD PARTY INTELLECTUAL PROPERTY RIGHTS.

These resources are intended for skilled developers designing with TI products. You are solely responsible for (1) selecting the appropriate TI products for your application, (2) designing, validating and testing your application, and (3) ensuring your application meets applicable standards, and any other safety, security, or other requirements. These resources are subject to change without notice. TI grants you permission to use these resources only for development of an application that uses the TI products described in the resource. Other reproduction and display of these resources is prohibited. No license is granted to any other TI intellectual property right or to any third party intellectual property right. TI disclaims responsibility for, and you will fully indemnify TI and its representatives against, any claims, damages, costs, losses, and liabilities arising out of your use of these resources.

TI's products are provided subject to TI's Terms of Sale (www.ti.com/legal/termsofsale.html) or other applicable terms available either on ti.com or provided in conjunction with such TI products. TI's provision of these resources does not expand or otherwise alter TI's applicable warranties or warranty disclaimers for TI products.

Mailing Address: Texas Instruments, Post Office Box 655303, Dallas, Texas 75265
Copyright © 2018, Texas Instruments Incorporated

Looking for pricing, stock, or lifecycle information?

Click below to explore more details on WIN SOURCE:

 [View ADS62C15IRGCR on WIN SOURCE](#)

 [Texas Instruments](#) Information

Optimize Your Supply Chain with WIN SOURCE Solutions

-  Global Sourcing Solution
-  Obsolete Management
-  Cost Control Management
-  Shortage Management
-  Alternative Solution
-  Excess Inventory Management