



**THE DATASHEET OF
NB4N507ADR2G**



NB4N507A

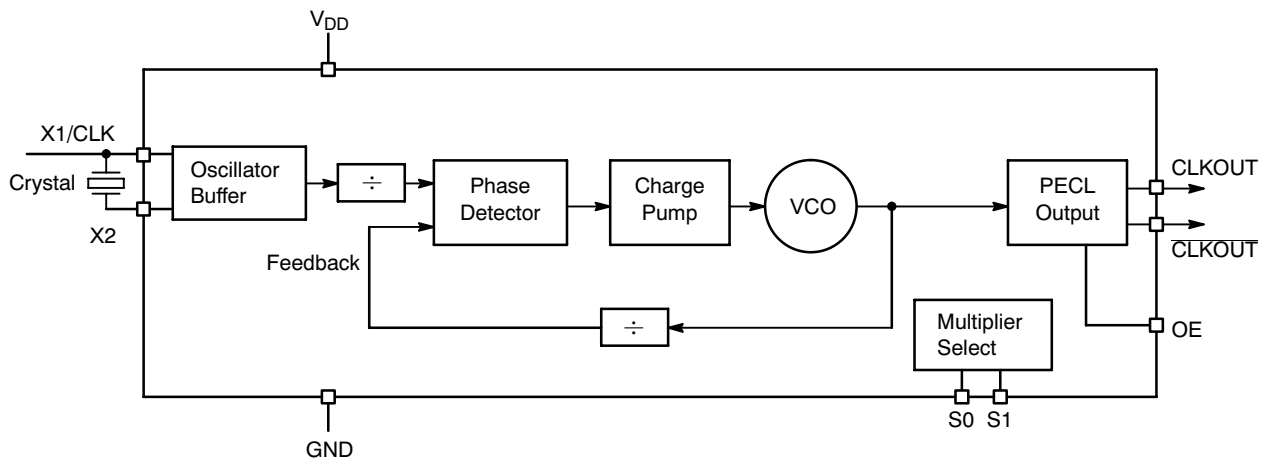

Figure 2. NB4N507A Logic Diagram

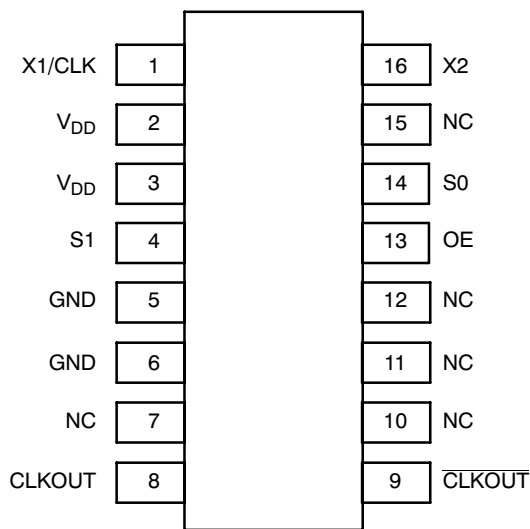

Figure 3. 16-Pin SOIC (Top View)

Table 1. CLOCK MULTIPLIER SELECT TABLE

S1	S0	Multiplier
L	L	9.72X*
L	M	10X
L	H	12X
M	L	6.25X
M	M	8X
M	H	5X
H	L	NA
H	M	3X
H	H	4X

*Example Crystal = 16 MHz, $f_{CLKOUT} = 155.52$ MHz
 L = GND
 H = V_{DD}
 M = OPEN

Table 2. OE, OUTPUT ENABLE FUNCTION

OE	Function
0	Disable
1	Enable

NB4N507A

Table 3. PIN DESCRIPTION

Pin # SOIC-16	Name	I/O	Description
1	X1/CLK	Crystal Input	Crystal or Clock Input
2,3	V _{DD}	Power Supply	Positive Supply Voltage (3.0 V to 5.5 V)
4	S1	Tri-Level Input	Multiplier Select Pin; When Left Open, Defaults to V _{DD} ÷ 2
5,6	GND	Power Supply	Negative Supply Voltage
7,10,11,12, 15	NC	No Connect	Pin 10 does not require an external resistor. The NB4N507A will function with or without a resistor on Pin 10.
8	CLKOUT	PECL Output*	Non-inverted differential PECL clock output.
9	$\overline{\text{CLKOUT}}$	PECL Output*	Inverted differential PECL clock output.
13	OE	(LV)CMOS/(LV)TTL Input	Output Enable for the CLKOUT/ $\overline{\text{CLKOUT}}$ Outputs. Outputs are enabled when HIGH or when left open; OE pin has internal pullup resistor. Disables both outputs when LOW. CLKOUT goes LOW, $\overline{\text{CLKOUT}}$ goes HIGH.
14	S0	Tri-Level Input	Multiplier Select Pin; When Left Open, Defaults to V _{DD} ÷ 2
16	X2	Crystal Input	Crystal Input

*The PECL Outputs are 15 mA open collector and must be DC loaded and AC terminated. See Figures 4, 5 and 6.

Table 4. ATTRIBUTES

Characteristics	Value
ESD Protection	Human Body Model Machine Model Charged Device Model
	> 1 kV > 150 V > 1 kV
Moisture Sensitivity, Indefinite Time Out of Drypack (Note 1)	Level 1
Flammability Rating	Oxygen Index: 28 to 34
	UL 94 V-0 @ 0.125 in
Transistor Count	1145 Devices
Meets or exceeds JEDEC Spec EIA/JESD78 IC Latchup Test	

1. For additional information, see Application Note AND8003/D.

Table 5. MAXIMUM RATINGS

Symbol	Parameter	Condition 1	Condition 2	Rating	Unit
V _{CC}	Positive Power Supply	GND = 0 V		6	V
V _I	Input Voltage			GND - 0.5 ≤ V _I ≤ V _{DD} + 0.5	V
T _A	Operating Temperature Range			-40 to +85	°C
T _{stg}	Storage Temperature Range			-65 to +150	°C
θ _{JA}	Thermal Resistance (Junction-to-Ambient)	0 lfpm 500 lfpm	SOIC-16	100 60	°C/W °C/W
θ _{JC}	Thermal Resistance (Junction-to-Case)	(Note 2)	SOIC-16	33 to 36	°C/W
T _{sol}	Wave Solder	Pb < 3 sec @ 248°C Pb-Free < 3 sec @ 260°C		265 265	°C

Stresses exceeding Maximum Ratings may damage the device. Maximum Ratings are stress ratings only. Functional operation above the Recommended Operating Conditions is not implied. Extended exposure to stresses above the Recommended Operating Conditions may affect device reliability.

2. JEDEC standard multilayer board - 2S2P (2 signal, 2 power).

NB4N507A

Table 6. DC CHARACTERISTICS ($V_{DD} = 3.0\text{ V to }5.5\text{ V}$, $GND = 0\text{ V}$, $T_A = -40^\circ\text{C to }+85^\circ\text{C}$ (Note 3))

Symbol	Characteristic	Min	Typ	Max	Unit	
I_{DD}	Power Supply Current (does not include output load resistor current)	$V_{DD} = 5\text{ V}$ $V_{DD} = 3.3\text{ V}$	15 10	27 23	35 30	mA mA
V_{OH}	Output HIGH Voltage (Notes 5 & 6)	$V_{DD} = 5\text{ V}$ $V_{DD} = 3.3\text{ V}$	3.95 2.57	4.05 2.67	4.15 2.77	V
V_{OL}	Output LOW Voltage (Notes 5 & 6)	$V_{DD} = 5\text{ V}$ $V_{DD} = 3.3\text{ V}$	3.12 1.90	3.20 2.00	3.30 2.10	V
V_{IH}	Input HIGH Voltage (Note 4)	S0, S1, X1/CLK OE	$V_{DD} - 0.5$ 2.0		V_{DD}	V
V_{IL}	Input LOW Voltage, (Note 4)	S0, S1, X1/CLK OE	0		0.5 0.8	V
C_x	Internal Crystal Capacitance, X1 & X2			0		pF
C_{in}	Input Capacitance, S0, S1, OE			5.0		pF

NOTE: Device will meet the specifications after thermal equilibrium has been established when mounted in a test socket or printed circuit board with maintained transverse airflow greater than 500 lfpm. Electrical parameters are guaranteed only over the declared operating temperature range. Functional operation of the device exceeding these conditions is not implied. Device specification limit values are applied individually under normal operating conditions and not valid simultaneously.

- PECL output parameters vary 1:1 with V_{DD} .
- S0 and S1 default to $V_{DD} \div 2$ when left open.

Table 7. AC CHARACTERISTICS ($V_{DD} = 3.0\text{ V to }5.5\text{ V}$, $GND = 0\text{ V}$, $T_A = -40^\circ\text{C to }+85^\circ\text{C}$ (Note 5))

Symbol	Characteristic	Min	Typ	Max	Unit
f_{xtal}	Crystal Input Frequency (Note 7)	10		27	MHz
f_{CLK}	Input Clock Frequency (Note 8)	5		52	MHz
f_{OUT}	Output Frequency Range	50		200	MHz
$V_{out\ pk-pk}$	Output Amplitude	550	680		mV
DC	Clock Output Duty Cycle (Note 8)	48		52	%
PLL _{BW}	PLL Bandwidth (Note 8)	10			kHz
$t_{jitter\ (pd)}$	Period Jitter (RMS, 1 σ , 10,000 Cycles)			10	ps
$t_{jitter\ (pd)}$	Period Jitter (Peak-to-Peak, 10,000 Cycles)			± 20	ps
t_r/t_f	Output Rise and Fall Times (Note 8)	50	270	500	ps

NOTE: Device will meet the specifications after thermal equilibrium has been established when mounted in a test socket or printed circuit board with maintained transverse airflow greater than 500 lfpm. Electrical parameters are guaranteed only over the declared operating temperature range. Functional operation of the device exceeding these conditions is not implied. Device specification limit values are applied individually under normal operating conditions and not valid simultaneously.

- PECL outputs loaded with external resistors for proper operation (see Figures 4, 5 and 6).
- V_{OH} and V_{OL} can be set by the external resistors, which can be modified.
- The crystal should be fundamental mode, parallel resonant. Do not use third overtone. For exact tuning when using a crystal, capacitors should be connected from pins X1 to ground and X2 to ground. The value of these capacitors is given by the following equation, where CL is the specified crystal load capacitance: Crystal caps (pF) = (CL-5) x 2. So, for a crystal with 16 pF load capacitance, use two 22 pF caps, including board trace capacitance (see Figure 7).
- Guaranteed by design and characterization.

NB4N507A

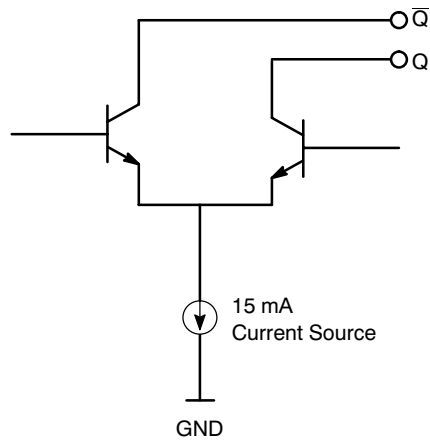

Figure 4. Output Structure

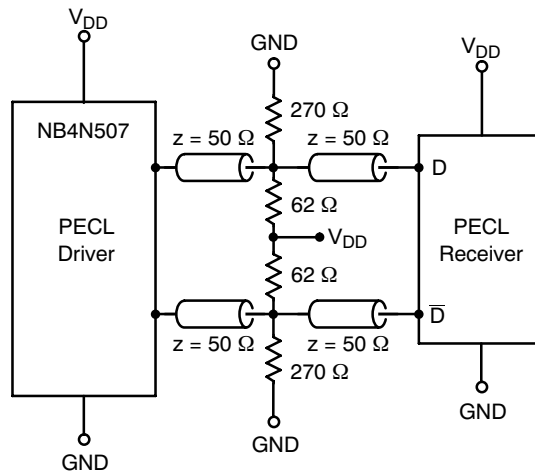

Figure 5. Evaluation Test Load for the NB4N507A

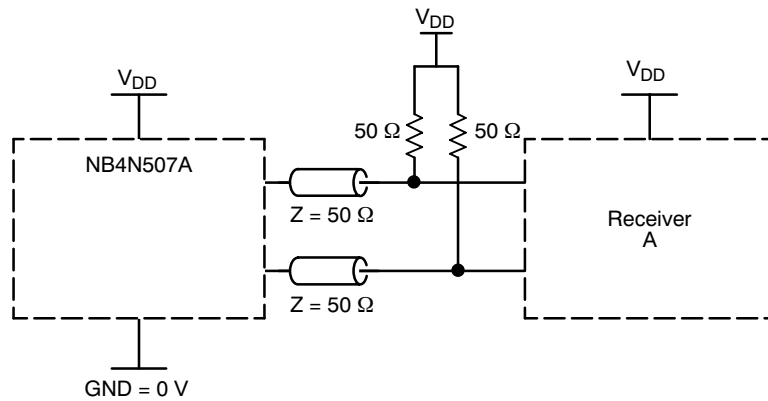

Figure 6. Alternate Termination for Output Driver and Device Evaluation

NB4N507A

APPLICATIONS INFORMATION

High Frequency Differential PECL Oscillators: The NB4N507A, along with a low frequency fundamental mode crystal, can build a high frequency differential PECL output oscillator. For example, a 10 MHz crystal connected to the NB4N507A with the 12X output selected (S1 = 0, S0 = 1) produces a 120 MHz PECL output clock.

Crystal Oscillator Input Interface

The NB4N507A features an integrated crystal oscillator to minimize system implementation costs. The oscillator circuit is a parallel resonant circuit and thus, for optimum performance, a parallel resonant crystal should be used.

As the oscillator is somewhat sensitive to loading on its inputs, the user is advised to mount the crystal as close to the NB4N507A as possible to avoid any board level parasitics. Surface mount crystals are recommended, but not required.

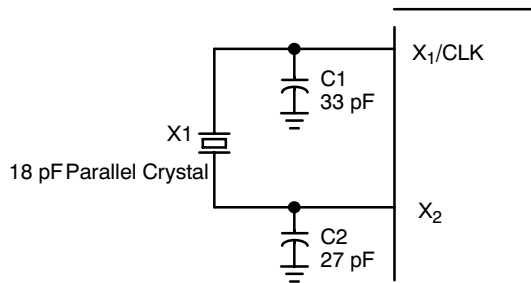

Figure 7. Crystal Input Interface

High Frequency VCXO: The bandwidth of the PLL is guaranteed to be greater than 10 kHz. This means that the PLL will track any modulation on the input with a frequency of less than 10 kHz. By using this property, a low frequency VCXO can be built. The output can then be multiplied by the NB4N507A, thereby producing a high frequency VCXO.

High Frequency TCXO: Extending the previous application, an inexpensive, low frequency TCXO can be built and the output frequency can be multiplied using the NB4N507A. Since the output of the chip is phase-locked to the input, the NB4N507A has no temperature dependence, and the temperature coefficient of the combined system is the same as that of the low frequency TCXO.

Decoupling and External Components

The NB4N507A requires a 0.01 μ F decoupling capacitor to be connected between V_{DD} and GND on pins 2 and 5. It must be connected close to the NB4N507A. Other V_{DD} and GND connections should be connected to those pins, or to the V_{DD} and GND planes on the board. Another four resistors are needed for the PECL outputs as shown in Figure 4. Suggested values of these resistors are shown, but they can be varied to change the differential pair output swing, and the DC level.

ORDERING INFORMATION

Device	Package	Shipping [†]
NB4N507AD	SOIC-16	48 Units / Rail
NB4N507ADG	SOIC-16 (Pb-Free)	48 Units / Rail
NB4N507ADR2	SOIC-16	2500 / Tape & Reel
NB4N507ADR2G	SOIC-16 (Pb-Free)	2500 / Tape & Reel

[†]For information on tape and reel specifications, including part orientation and tape sizes, please refer to our Tape and Reel Packaging Specifications Brochure, BRD8011/D.

Resource Reference of Application Notes

- AN1405/D** - ECL Clock Distribution Techniques
- AN1406/D** - Designing with PECL (ECL at +5.0 V)
- AN1503/D** - ECLinPS™ I/O SPICE Modeling Kit
- AN1504/D** - Metastability and the ECLinPS Family
- AN1568/D** - Interfacing Between LVDS and ECL
- AN1672/D** - The ECL Translator Guide
- AND8090/D** - AC Characteristics of ECL Devices

NB4N507A

Resource Reference of Application Notes

- AND8001/D** - Odd Number Counters Design
- AND8002/D** - Marking and Date Codes
- AND8020/D** - Termination of ECL Logic Devices
- AND8066/D** - Interfacing with ECLinPS
- AND8090/D** - AC Characteristics of ECL Devices

NB4N507A

PACKAGE DIMENSIONS

SOIC-16
D SUFFIX
CASE 751B-05
ISSUE J

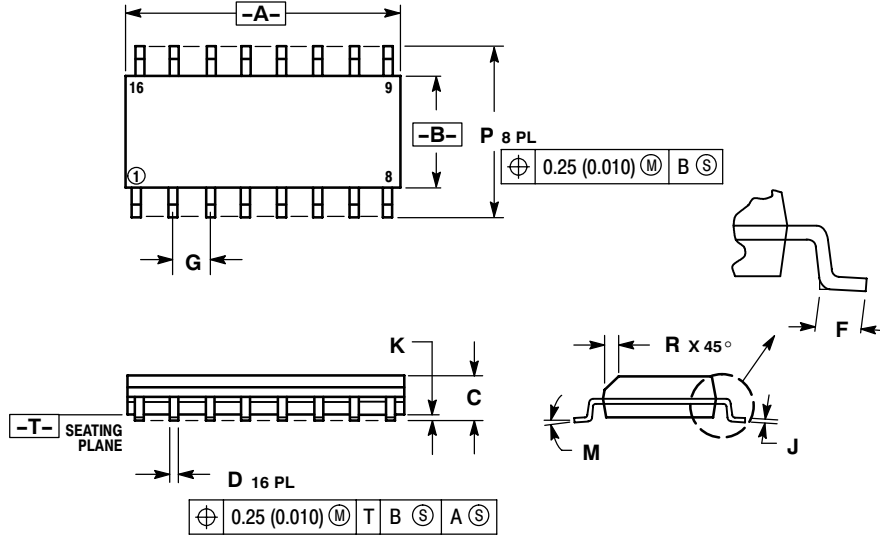

- NOTES:
1. DIMENSIONING AND TOLERANCING PER ANSI Y14.5M, 1982.
 2. CONTROLLING DIMENSION: MILLIMETER.
 3. DIMENSIONS A AND B DO NOT INCLUDE MOLD PROTRUSION.
 4. MAXIMUM MOLD PROTRUSION 0.15 (0.006) PER SIDE.
 5. DIMENSION D DOES NOT INCLUDE DAMBAR PROTRUSION. ALLOWABLE DAMBAR PROTRUSION SHALL BE 0.127 (0.005) TOTAL IN EXCESS OF THE D DIMENSION AT MAXIMUM MATERIAL CONDITION.

DIM	MILLIMETERS		INCHES	
	MIN	MAX	MIN	MAX
A	9.80	10.00	0.386	0.393
B	3.80	4.00	0.150	0.157
C	1.35	1.75	0.054	0.068
D	0.35	0.49	0.014	0.019
F	0.40	1.25	0.016	0.049
G	1.27 BSC		0.050 BSC	
J	0.19	0.25	0.008	0.009
K	0.10	0.25	0.004	0.009
M	0 $^\circ$	7 $^\circ$	0 $^\circ$	7 $^\circ$
P	5.80	6.20	0.229	0.244
R	0.25	0.50	0.010	0.019

ECLinPS is a trademark of Semiconductor Components Industries, LLC (SCILLC).

ON Semiconductor and are registered trademarks of Semiconductor Components Industries, LLC (SCILLC). SCILLC reserves the right to make changes without further notice to any products herein. SCILLC makes no warranty, representation or guarantee regarding the suitability of its products for any particular purpose, nor does SCILLC assume any liability arising out of the application or use of any product or circuit, and specifically disclaims any and all liability, including without limitation special, consequential or incidental damages. "Typical" parameters which may be provided in SCILLC data sheets and/or specifications can and do vary in different applications and actual performance may vary over time. All operating parameters, including "Typicals" must be validated for each customer application by customer's technical experts. SCILLC does not convey any license under its patent rights nor the rights of others. SCILLC products are not designed, intended, or authorized for use as components in systems intended for surgical implant into the body, or other applications intended to support or sustain life, or for any other application in which the failure of the SCILLC product could create a situation where personal injury or death may occur. Should Buyer purchase or use SCILLC products for any such unintended or unauthorized application, Buyer shall indemnify and hold SCILLC and its officers, employees, subsidiaries, affiliates, and distributors harmless against all claims, costs, damages, and expenses, and reasonable attorney fees arising out of, directly or indirectly, any claim of personal injury or death associated with such unintended or unauthorized use, even if such claim alleges that SCILLC was negligent regarding the design or manufacture of the part. SCILLC is an Equal Opportunity/Affirmative Action Employer. This literature is subject to all applicable copyright laws and is not for resale in any manner.

PUBLICATION ORDERING INFORMATION

LITERATURE FULFILLMENT:
Literature Distribution Center for ON Semiconductor
RD, Box 5163, Denver, Colorado 80217 USA
Phone: 303-675-2175 or 800-344-3860 Toll Free USA/Canada
Fax: 303-675-2176 or 800-344-3867 Toll Free USA/Canada
Email: orderlit@onsemi.com

N. American Technical Support: 800-282-9855 Toll Free
USA/Canada
Europe, Middle East and Africa Technical Support:
Phone: 421 33 790 2910
Japan Customer Focus Center
Phone: 81-3-5773-3850

ON Semiconductor Website: www.onsemi.com
Order Literature: <http://www.onsemi.com/orderlit>
For additional information, please contact your local Sales Representative

Looking for pricing, stock, or lifecycle information?

Click below to explore more details on WIN SOURCE:

 [View NB4N507ADR2G on WIN SOURCE](#)

 [ON Semiconductor](#) Information

Optimize Your Supply Chain with WIN SOURCE Solutions

-  Global Sourcing Solution
-  Obsolete Management
-  Cost Control Management
-  Shortage Management
-  Alternative Solution
-  Excess Inventory Management