



Is Now Part of



ON Semiconductor®

To learn more about ON Semiconductor, please visit our website at
www.onsemi.com

Please note: As part of the Fairchild Semiconductor integration, some of the Fairchild orderable part numbers will need to change in order to meet ON Semiconductor's system requirements. Since the ON Semiconductor product management systems do not have the ability to manage part nomenclature that utilizes an underscore (_), the underscore (_) in the Fairchild part numbers will be changed to a dash (-). This document may contain device numbers with an underscore (_). Please check the ON Semiconductor website to verify the updated device numbers. The most current and up-to-date ordering information can be found at www.onsemi.com. Please email any questions regarding the system integration to Fairchild_questions@onsemi.com.

ON Semiconductor and the ON Semiconductor logo are trademarks of Semiconductor Components Industries, LLC dba ON Semiconductor or its subsidiaries in the United States and/or other countries. ON Semiconductor owns the rights to a number of patents, trademarks, copyrights, trade secrets, and other intellectual property. A listing of ON Semiconductor's product/patent coverage may be accessed at www.onsemi.com/site/pdf/Patent-Marking.pdf. ON Semiconductor reserves the right to make changes without further notice to any products herein. ON Semiconductor makes no warranty, representation or guarantee regarding the suitability of its products for any particular purpose, nor does ON Semiconductor assume any liability arising out of the application or use of any product or circuit, and specifically disclaims any and all liability, including without limitation special, consequential or incidental damages. Buyer is responsible for its products and applications using ON Semiconductor products, including compliance with all laws, regulations and safety requirements or standards, regardless of any support or applications information provided by ON Semiconductor. "Typical" parameters which may be provided in ON Semiconductor data sheets and/or specifications can and do vary in different applications and actual performance may vary over time. All operating parameters, including "Typicals" must be validated for each customer application by customer's technical experts. ON Semiconductor does not convey any license under its patent rights nor the rights of others. ON Semiconductor products are not designed, intended, or authorized for use as a critical component in life support systems or any FDA Class 3 medical devices or medical devices with a same or similar classification in a foreign jurisdiction or any devices intended for implantation in the human body. Should Buyer purchase or use ON Semiconductor products for any such unintended or unauthorized application, Buyer shall indemnify and hold ON Semiconductor and its officers, employees, subsidiaries, affiliates, and distributors harmless against all claims, costs, damages, and expenses, and reasonable attorney fees arising out of, directly or indirectly, any claim of personal injury or death associated with such unintended or unauthorized use, even if such claim alleges that ON Semiconductor was negligent regarding the design or manufacture of the part. ON Semiconductor is an Equal Opportunity/Affirmative Action Employer. This literature is subject to all applicable copyright laws and is not for resale in any manner.



FSAV433 — High-Bandwidth (550MHz), 3-Channel, 3:1 Video Switch

Features

- Ground between Channels to Optimize Isolation and Reduce Hostile Crosstalk
- -70dB Non-Adjacent Channel Crosstalk at 30MHz
- On Resistance: 6.5Ω (Typical)
- -3dB Bandwidth: 550MHz
- Low Power Consumption: 1μA (Maximum)

Applications

- RGB Video Switch in LCD, Plasma and Projector Displays
- DVD-RW

Description

The FSAV433 is an ultra-low power, high-bandwidth video switch specially designed for switching three analog video signals, including computer RGB and high-definition YPbPr signals. The wide bandwidth (550MHz) of the switch allows signal passage with minimum edge and phase distortion, while -70dB non-adjacent channel crosstalk generates negligible image noise between active channels. Optimized differential gain and phases maintain the image integrity of video applications, while low on resistance offers low signal insertion loss.

The Fairchild switch family derives from and embodies Fairchild's proven switch technology used for years in its 74LVX3L384 (FST3384) bus switch product.

Ordering Information

Part Number	Operating Temperature Range	Package	Packing Method
FSAV433MTCX	-40 to +85°C	20-Lead, Thin Shrink Small Outline Package (TSSOP), JEDEC MO-153, 4.4mm Wide	Tape and Reel

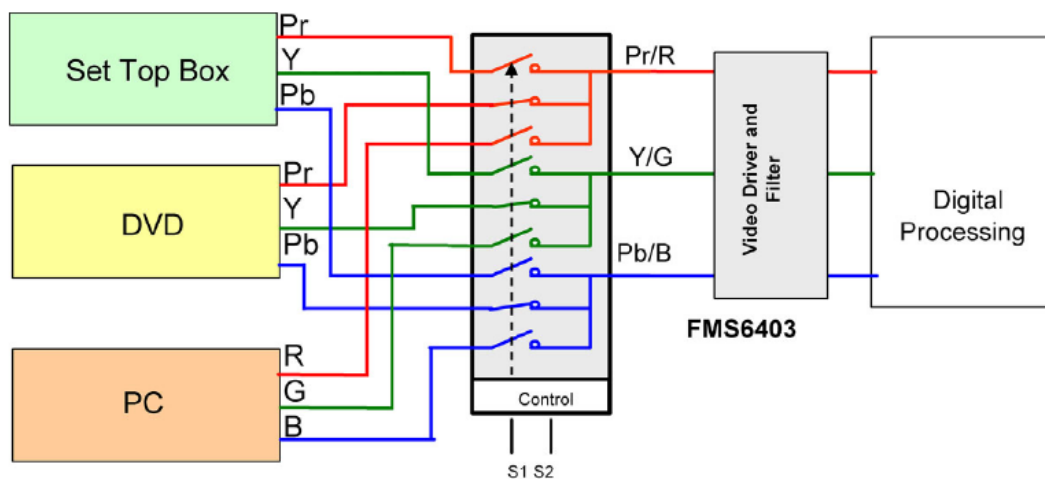

Figure 1. Typical Application Diagram

Pin Configurations

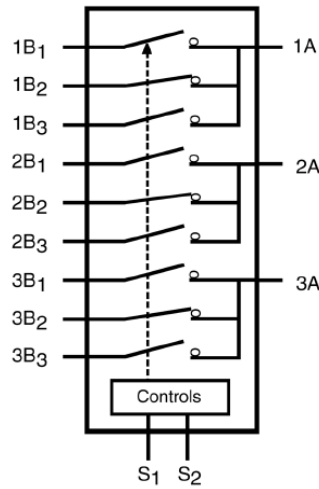

Figure 2. Analog Symbol

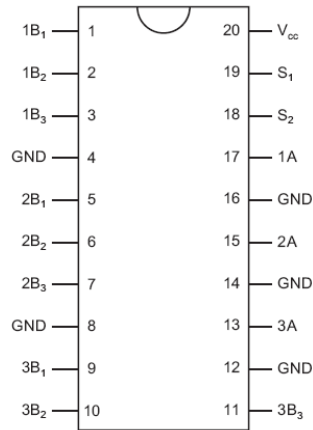

Figure 3. TSSOP Pin Assignments (Top Through View)

Pin Descriptions

Pin #	Name	Description
1, 2, 3, 5, 6, 7, 9, 10, 11	1B ₁ , 2B ₂ , 3B ₂	Bus B
4, 8, 12, 14, 16	GND	Ground
13, 15, 17	1A, 2A, 3A	Bus A
18, 19	S ₁ , S ₂	Select Input
20	V _{CC}	Supply Voltage

Truth Table

S ₁	S ₂	Function
LOW	LOW	Disconnected
LOW	HIGH	A=B ₁
HIGH	LOW	A=B ₂
HIGH	HIGH	A=B ₃

Absolute Maximum Ratings

Stresses exceeding the absolute maximum ratings may damage the device. The device may not function or be operable above the recommended operating conditions and stressing the parts to these levels is not recommended. In addition, extended exposure to stresses above the recommended operating conditions may affect device reliability. The absolute maximum ratings are stress ratings only.

Symbol	Parameter	Min.	Max.	Unit
V_{CC}	Supply Voltage	-0.5	+4.6	V
V_S	DC Switch Voltage	-0.5	$V_{CC}+0.5$	V
V_{IN}	DC Input Voltage ⁽¹⁾	-0.5	+4.6	V
I_{IK}	DC Input Diode Current, $V_{IN} < 0V$	-50		mA
I_{OUT}	DC Output Sink Current		100	mA
I_{CC}/I_{GND}	DC V_{CC} / GND Current		±100	mA
T_{STG}	Storage Temperature Range	-65	+150	°C
ESD	Human Body Model, JESD22-A114		7000	V

Note:

- The input and output negative voltage ratings may be exceeded if the input and output diode current ratings are observed.

Recommended Operating Conditions

The Recommended Operating Conditions table defines the conditions for actual device operation. Recommended operating conditions are specified to ensure optimal performance to the datasheet specifications. Fairchild does not recommend exceeding them or designing to Absolute Maximum Ratings.

Symbol	Parameter	Min.	Max.	Unit
V_{CC}	Power Supply Operating	2.3	3.6	V
V_{IN}	Input Voltage	0	V_{CC}	V
T_A	Operating Temperature, Free Air	-40	+85	°C

Note:

- Unused control inputs must be held HIGH or LOW; they may not float.

DC Electrical Characteristics

Typical values are at $T_A = +25^\circ\text{C}$.

Symbol	Parameter	Conditions	V_{CC} (V)	$T_A = -40 \text{ to } +85^\circ\text{C}$			Units
				Min.	Typ.	Max.	
V_{ANALOG}	Analog Signal Range		2.3 to 3.0	0		2	V
V_{IK}	Clamp Diode Voltage	$I_{IN} = -18\text{mA}$	3.0			-1.2	V
V_{IH}	High-Level Input Voltage		2.3	1.8			V
			3.0 to 3.6	2.0			V
V_{IL}	Low-Level Input Voltage		2.3			0.8	V
			3.0 to 3.6				V
I_I	Input Leakage Current	$0 \leq V_{IN} \leq 3.6V$	3.6			±1.0	μA
I_{OFF}	Off-State Leakage Current	$0 \leq A, B \leq V_{CC}$, See Figure 9	3.6			±1.0	μA
R_{ON}	Switch On Resistance ⁽³⁾	$V_{IN} = 1.0V$, $I_{ON} = 13\text{mA}$, See Figure 7	2.3		9.0	13.0	Ω
			3.0		6.5	9.0	
		$V_{IN} = 2.0V$, $I_{ON} = 26\text{mA}$, See Figure 7	2.3		10.0	15.0	
			3.0		6.5	9.0	
I_{CC}	Quiescent Supply Current	$V_{IN} = V_{CC}$ or GND, $I_{OUT} = 0$	3.6			1	μA
I_{CCT}	Increase in I_{CC} per Input	One Control Input at 3.0V Other Inputs at V_{CC} or GND	3.6			10	μA

Note:

- Measured by the voltage drop between the A and B pins at the indicated current through the switch. On resistance is determined by the lower of the voltages on the A or B pins.

AC Electrical Characteristics

Typical values are at $V_{CC}=3.3V$ and $T_A=+25^{\circ}C$.

Symbol	Parameter	Conditions	V_{CC}	$T_A=-40\text{ to }+85^{\circ}C$			Units	Figure
				Min.	Typ.	Max.		
t_{ON}	Turn On Time S to Bus A	$V_B=2V$	3.0 to 3.6			5.5	ns	Figure 8, Figure 10
			2.3 to 2.7			7		
t_{OFF}	Turn Off Time S to Bus A	$V_B=2V$	3.0 to 3.6			4	ns	Figure 8, Figure 10
			2.3 to 2.7			5		
D_G	Differential Gain	$R_L=75\Omega$, $f=3.58MHz$	3.0 to 3.6		0.2		%	
D_P	Differential Phase	$R_L=75\Omega$, $f=3.58MHz$	3.0 to 3.6		0.1		$^{\circ}$	
O_{IRR}	Non-Adjacent Off Isolation	$R_L=75\Omega$, $f=30MHz$	3.0 to 3.6		-45		dB	Figure 13
	Adjacent Off Isolation		2.3 to 2.7		-45			
X_{TALK}	Non-Adjacent Channel Crosstalk	$R_L=75\Omega$, $f=30MHz$	3.0 to 3.6		-70		dB	Figure 15
	Adjacent Channel Crosstalk		2.3 to 2.7		-70			Figure 14
B_W	-3dB Bandwidth	$R_L=50\Omega$	3.0 to 3.6		550		MHz	Figure 12
		$R_L=75\Omega$			300			

Capacitance

Typical values are at $V_{CC}=3.3V$ and $T_A=+25^{\circ}C$.

Symbol	Parameter	Conditions	Typ.	Units	Figure
C_{IN}	Control Pin Input Capacitance	$V_{CC}=0V$	3	pF	
C_{ON}	A/B On Capacitance	$V_{CC}=3.0V=0V$	15	pF	Figure 17
C_{OFF}	Port B Off Capacitance	$V_{CC}=3.3V$	4	pF	Figure 16

Typical Characteristics

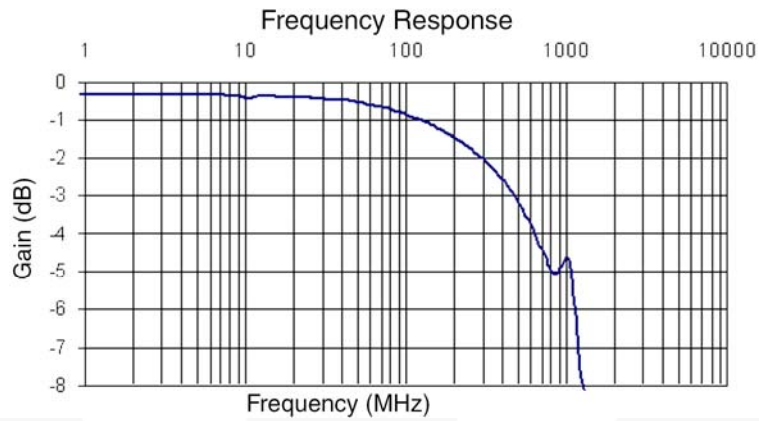

Figure 4. Gain vs. Frequency ($V_{BAIS}=0.5V$, $V_{CC}=3.6V$, $R_L=50\Omega$)

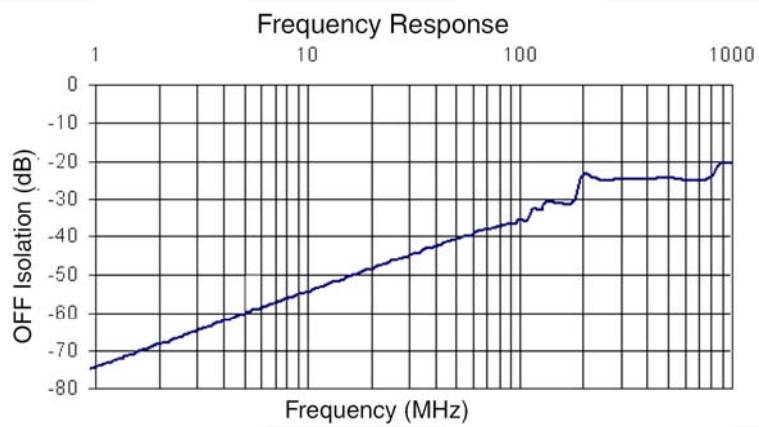

Figure 5. Off Isolation ($V_{BAIS}=0.5V$, $V_{CC}=3.0V$, $SEL_n=LOW$)

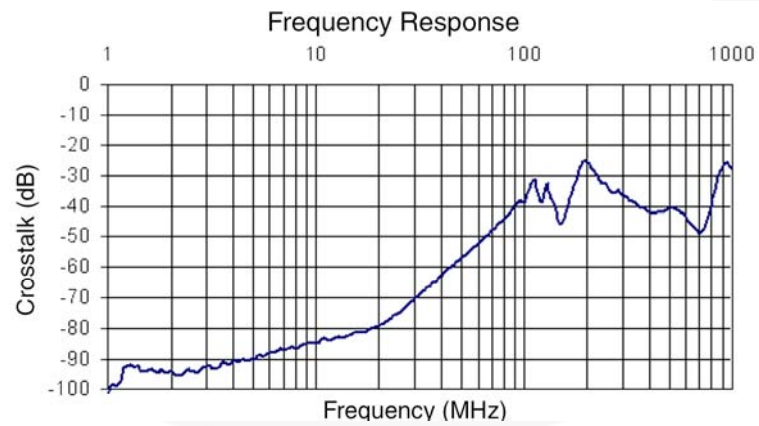

Figure 6. Crosstalk ($V_{BAIS}=0.5V$, $V_{CC}=3.0V$, $SEL_n=HIGH$)

Test Diagrams

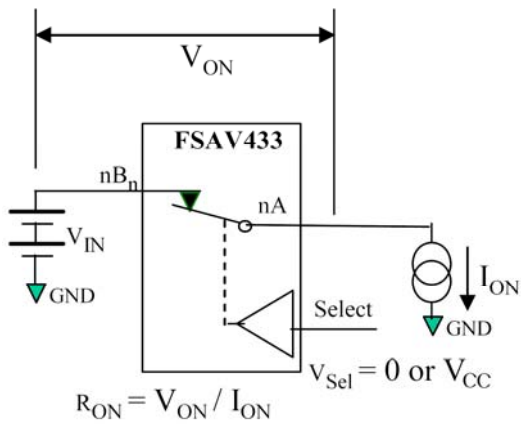
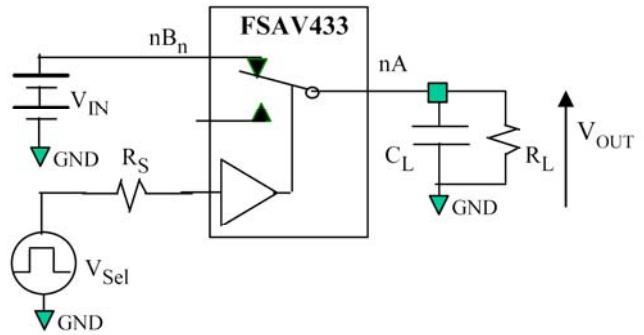

Figure 7. On Resistance



Note:

- R_L and C_L are functions of the application environment (50, 75, or 100Ω) C_L includes test fixture and stray capacitance.

Figure 8. Test Circuit Load

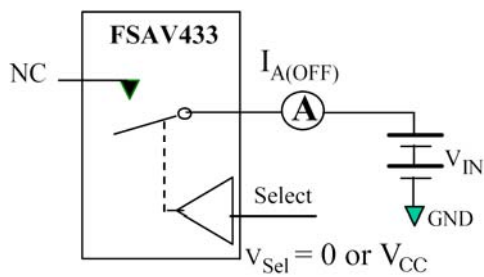

Figure 9. Off Leakage

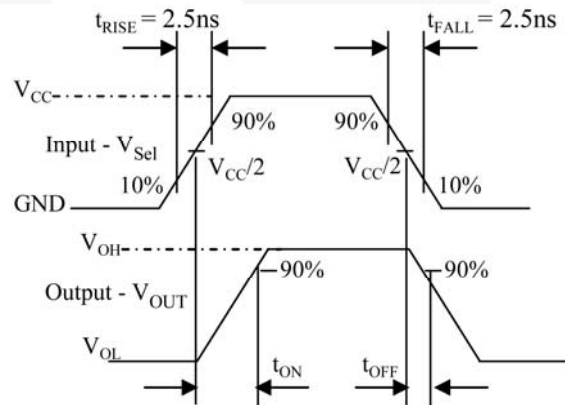

Figure 10. Turn On / Off Waveforms

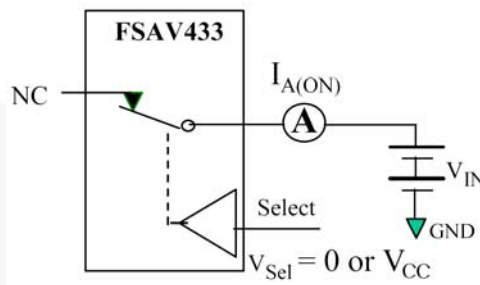
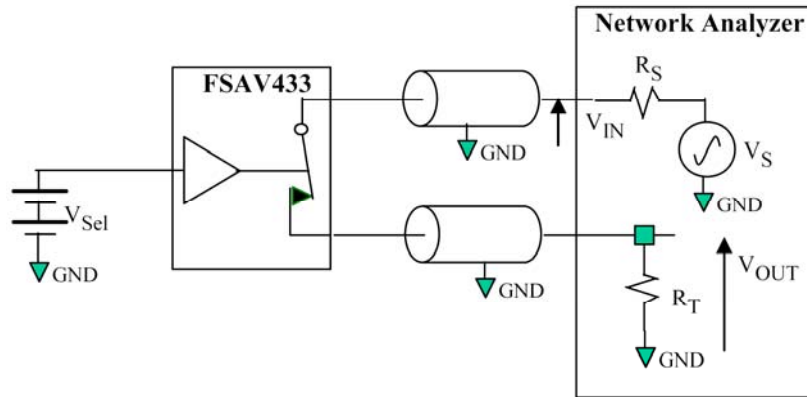

Figure 11. On Leakage

Test Diagrams (Continued)



Notes:

- 5. R_S and R_T are functions of the application environment (50, 75, or 100 Ω).

Figure 12. Bandwidth

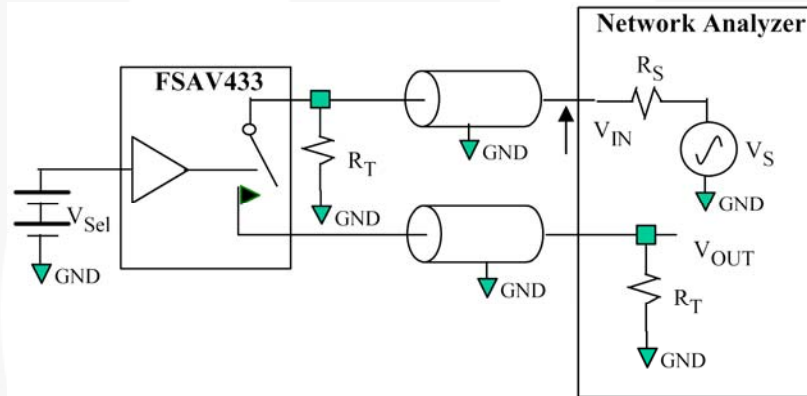

Notes:

- 6. R_S and R_T are functions of the application environment (50, 75, or 100 Ω).
- 7. Off isolation = $20 \text{ Log } (V_{OUT} / V_{IN})$.

Figure 13. Channel Off Isolation

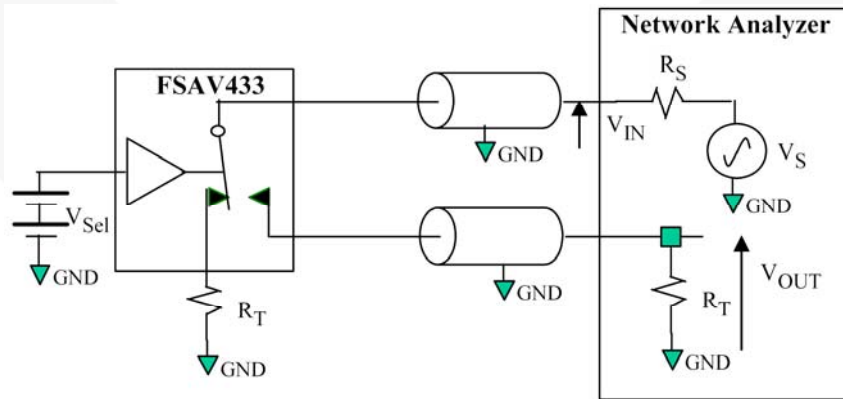

Note:

- 8. Crosstalk = $20 \text{ Log } (V_{OUT} / V_{IN})$.

Figure 14. Adjacent Channel Crosstalk

Test Diagrams (Continued)

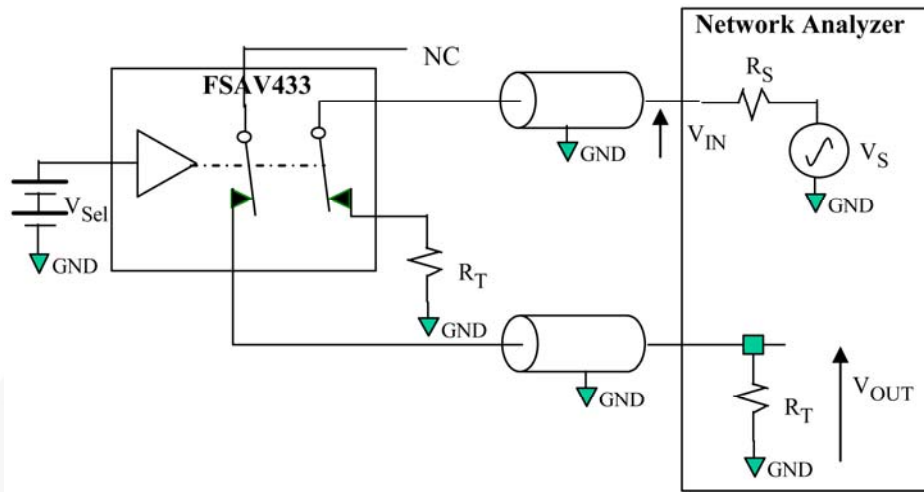

Notes:

- 9. R_S and R_T are functions of the application environment (50, 75, or 100 Ω).
- 10. Crosstalk = $20 \text{ Log} (V_{OUT} / V_{IN})$.

Figure 15. Non-Adjacent Channel-to-Channel Crosstalk

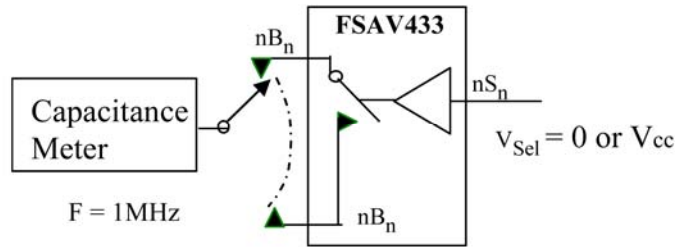

Figure 16. Channel Off Capacitance

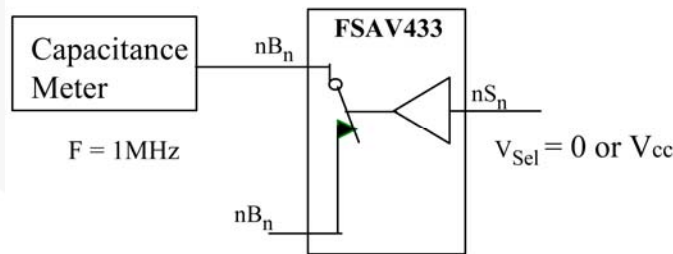
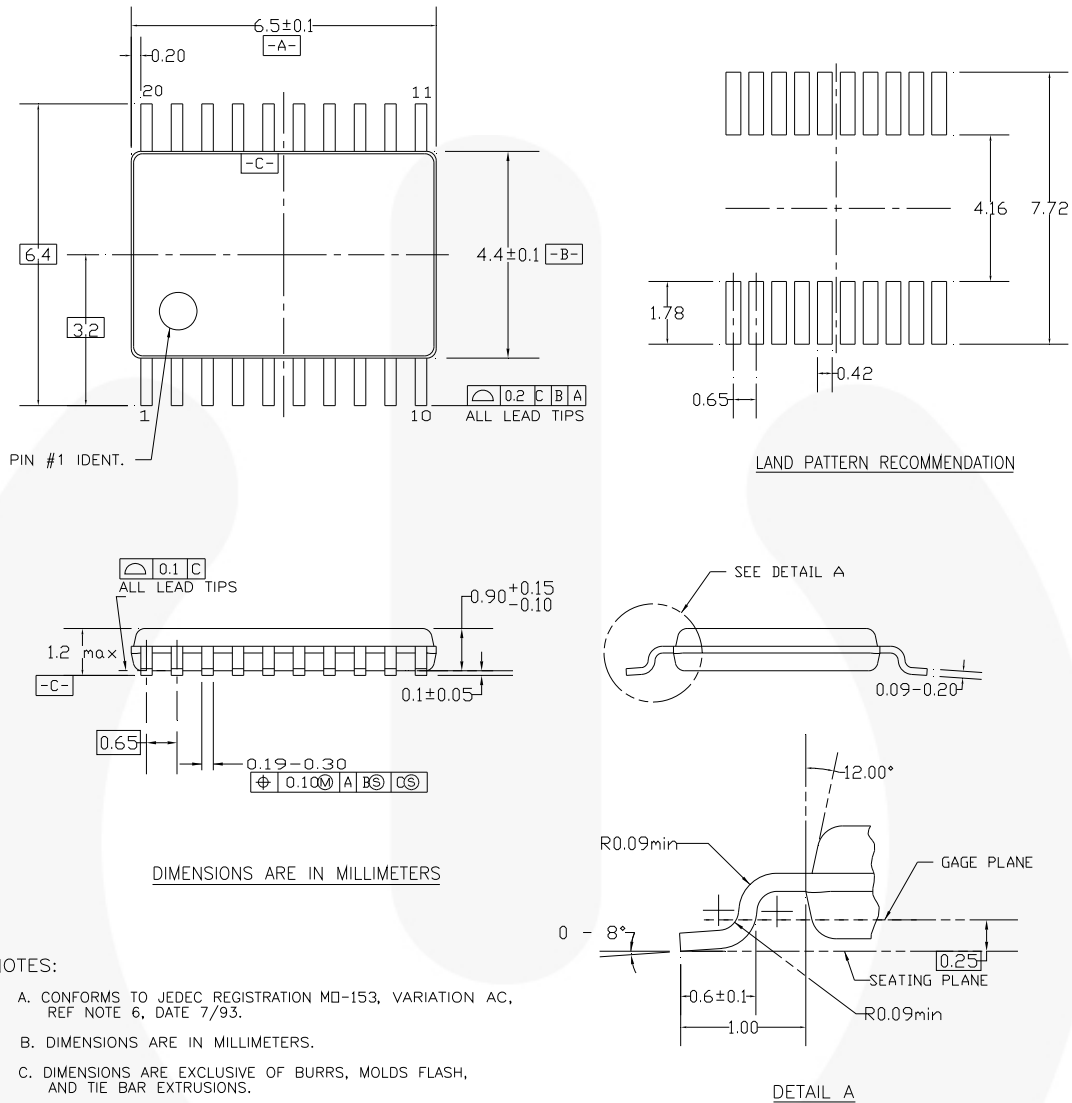

Figure 17. Channel On Capacitance

Physical Dimensions



MTC20REV D1

Figure 18. 20-Lead, Thin Shrink Small Outline Package (TSSOP)

Package drawings are provided as a service to customers considering Fairchild components. Drawings may change in any manner without notice. Please note the revision and/or date on the drawing and contact a Fairchild Semiconductor representative to verify or obtain the most recent revision. Package specifications do not expand the terms of Fairchild's worldwide terms and conditions, specifically the warranty therein, which covers Fairchild products.

Always visit Fairchild Semiconductor's online packaging area for the most recent package drawings:
<http://www.fairchildsemi.com/packaging>.



TRADEMARKS

The following includes registered and unregistered trademarks and service marks, owned by Fairchild Semiconductor and/or its global subsidiaries, and is not intended to be an exhaustive list of all such trademarks.

AccuPower™	F-PFS™	Power-SPM™	The Power Franchise®
Auto-SPM™	FRFET®	PowerTrench®	The Right Technology for Your Success™
AX-CAP™*	Global Power Resource™	PowerXS™	the power franchise
Build it Now™	Green FPST™	Programmable Active Droop™	TinyBoost™
CorePLUS™	Green FPST™ e-Series™	QFET®	TinyBuck™
CorePOWER™	Gmax™	QS™	TinyCalc™
CROSSVOLT™	GTO™	Quiet Series™	TinyLogic®
CTL™	IntelliMAX™	RapidConfigure™	TINYOPTO™
Current Transfer Logic™	ISOPLANAR™	™	TinyPower™
DEUXPEED®	MegaBuck™	Saving our world, 1mW/kW at a time™	TinyPWM™
Dual Cool™	MICROCOUPLER™	SignalWise™	TinyWire™
EcoSPARK®	MicroFET™	SmartMax™	TrnFault Detect™
EfficientMax™	MicroPak™	SMART START™	TRUECURRENT®*
ESBC™	MicroPak2™	SPM®	µSerDes™
F ®	MillerDrive™	STEALTH™	SerDes™
Fairchild®	MotionMax™	SuperFET®	UHC®
Fairchild Semiconductor®	Motion-SPM™	SuperSOT™3	Ultra FRFET™
FACT Quiet Series™	mWSaver™	SuperSOT™-6	UniFET™
FACT®	OptoHit™	SuperSOT™-8	Vcx™
FAST®	OPTOLOGIC®	SupreMOS®	VisualMax™
FastvCore™	OPTOPLANAR®	SynCFET™	XST™
FETBench™	™	Syn-Lock™	
FlashWriter®*	PDP SPM™	SYSTEM GENERAL®*	
FPST™			

* Trademarks of System General Corporation, used under license by Fairchild Semiconductor.

DISCLAIMER

FAIRCHILD SEMICONDUCTOR RESERVES THE RIGHT TO MAKE CHANGES WITHOUT FURTHER NOTICE TO ANY PRODUCTS HEREIN TO IMPROVE RELIABILITY, FUNCTION, OR DESIGN. FAIRCHILD DOES NOT ASSUME ANY LIABILITY ARISING OUT OF THE APPLICATION OR USE OF ANY PRODUCT OR CIRCUIT DESCRIBED HEREIN; NEITHER DOES IT CONVEY ANY LICENSE UNDER ITS PATENT RIGHTS, NOR THE RIGHTS OF OTHERS. THESE SPECIFICATIONS DO NOT EXPAND THE TERMS OF FAIRCHILD'S WORLDWIDE TERMS AND CONDITIONS, SPECIFICALLY THE WARRANTY THEREIN, WHICH COVERS THESE PRODUCTS.

LIFE SUPPORT POLICY

FAIRCHILD'S PRODUCTS ARE NOT AUTHORIZED FOR USE AS CRITICAL COMPONENTS IN LIFE SUPPORT DEVICES OR SYSTEMS WITHOUT THE EXPRESS WRITTEN APPROVAL OF FAIRCHILD SEMICONDUCTOR CORPORATION.

As used herein:

1. Life support devices or systems are devices or systems which, (a) are intended for surgical implant into the body or (b) support or sustain life, and (c) whose failure to perform when properly used in accordance with instructions for use provided in the labeling, can be reasonably expected to result in a significant injury of the user.
2. A critical component in any component of a life support, device, or system whose failure to perform can be reasonably expected to cause the failure of the life support device or system, or to affect its safety or effectiveness.

ANTI-COUNTERFEITING POLICY

Fairchild Semiconductor Corporation's Anti-Counterfeiting Policy. Fairchild's Anti-Counterfeiting Policy is also stated on our external website, www.fairchildsemi.com, under Sales Support.

Counterfeiting of semiconductor parts is a growing problem in the industry. All manufacturers of semiconductor products are experiencing counterfeiting of their parts. Customers who inadvertently purchase counterfeit parts experience many problems such as loss of brand reputation, substandard performance, failed applications, and increased cost of production and manufacturing delays. Fairchild is taking strong measures to protect ourselves and our customers from the proliferation of counterfeit parts. Fairchild strongly encourages customers to purchase Fairchild parts either directly from Fairchild or from Authorized Fairchild Distributors who are listed by country on our web page cited above. Products customers buy either from Fairchild directly or from Authorized Fairchild Distributors are genuine parts, have full traceability, meet Fairchild's quality standards for handling and storage and provide access to Fairchild's full range of up-to-date technical and product information. Fairchild and our Authorized Distributors will stand behind all warranties and will appropriately address any warranty issues that may arise. Fairchild will not provide any warranty coverage or other assistance for parts bought from Unauthorized Sources. Fairchild is committed to combat this global problem and encourage our customers to do their part in stopping this practice by buying direct or from authorized distributors.

PRODUCT STATUS DEFINITIONS

Definition of Terms

Datasheet Identification	Product Status	Definition
Advance Information	Formative / In Design	Datasheet contains the design specifications for product development. Specifications may change in any manner without notice.
Preliminary	First Production	Datasheet contains preliminary data; supplementary data will be published at a later date. Fairchild Semiconductor reserves the right to make changes at any time without notice to improve design.
No Identification Needed	Full Production	Datasheet contains final specifications. Fairchild Semiconductor reserves the right to make changes at any time without notice to improve the design.
Obsolete	Not In Production	Datasheet contains specifications on a product that is discontinued by Fairchild Semiconductor. The datasheet is for reference information only.

Rev. 153

ON Semiconductor and  are trademarks of Semiconductor Components Industries, LLC dba ON Semiconductor or its subsidiaries in the United States and/or other countries. ON Semiconductor owns the rights to a number of patents, trademarks, copyrights, trade secrets, and other intellectual property. A listing of ON Semiconductor's product/patent coverage may be accessed at www.onsemi.com/site/pdf/Patent-Marking.pdf. ON Semiconductor reserves the right to make changes without further notice to any products herein. ON Semiconductor makes no warranty, representation or guarantee regarding the suitability of its products for any particular purpose, nor does ON Semiconductor assume any liability arising out of the application or use of any product or circuit, and specifically disclaims any and all liability, including without limitation special, consequential or incidental damages. Buyer is responsible for its products and applications using ON Semiconductor products, including compliance with all laws, regulations and safety requirements or standards, regardless of any support or applications information provided by ON Semiconductor. "Typical" parameters which may be provided in ON Semiconductor data sheets and/or specifications can and do vary in different applications and actual performance may vary over time. All operating parameters, including "Typicals" must be validated for each customer application by customer's technical experts. ON Semiconductor does not convey any license under its patent rights nor the rights of others. ON Semiconductor products are not designed, intended, or authorized for use as a critical component in life support systems or any FDA Class 3 medical devices or medical devices with a same or similar classification in a foreign jurisdiction or any devices intended for implantation in the human body. Should Buyer purchase or use ON Semiconductor products for any such unintended or unauthorized application, Buyer shall indemnify and hold ON Semiconductor and its officers, employees, subsidiaries, affiliates, and distributors harmless against all claims, costs, damages, and expenses, and reasonable attorney fees arising out of, directly or indirectly, any claim of personal injury or death associated with such unintended or unauthorized use, even if such claim alleges that ON Semiconductor was negligent regarding the design or manufacture of the part. ON Semiconductor is an Equal Opportunity/Affirmative Action Employer. This literature is subject to all applicable copyright laws and is not for resale in any manner.

PUBLICATION ORDERING INFORMATION

LITERATURE FULFILLMENT:

Literature Distribution Center for ON Semiconductor
19521 E. 32nd Pkwy, Aurora, Colorado 80011 USA
Phone: 303-675-2175 or 800-344-3860 Toll Free USA/Canada
Fax: 303-675-2176 or 800-344-3867 Toll Free USA/Canada
Email: orderlit@onsemi.com

N. American Technical Support: 800-282-9855 Toll Free
USA/Canada
Europe, Middle East and Africa Technical Support:
Phone: 421 33 790 2910
Japan Customer Focus Center
Phone: 81-3-5817-1050

ON Semiconductor Website: www.onsemi.com
Order Literature: <http://www.onsemi.com/orderlit>
For additional information, please contact your local
Sales Representative

Looking for pricing, stock, or lifecycle information?

Click below to explore more details on WIN SOURCE:

- ⊖ [View FSAV433BQX on WIN SOURCE](#)
- ⊖ [Fairchild/ON Semiconductor Information](#)

Optimize Your Supply Chain with WIN SOURCE Solutions

- ✓ Global Sourcing Solution
- ✓ Obsolete Management
- ✓ Cost Control Management
- ✓ Shortage Management
- ✓ Alternative Solution
- ✓ Excess Inventory Management