



**THE DATASHEET OF
AD5301BRT-500RL7**



FEATURES

- AD5301:** buffered voltage output 8-bit DAC
- AD5311:** buffered voltage output 10-bit DAC
- AD5321:** buffered voltage output 12-bit DAC
- 6-lead SOT-23 and 8-lead MSOP packages
- Micropower operation: 120 μ A at 3 V
- 2-wire (I²C-compatible) serial interface
- Data readback capability
- 2.5 V to 5.5 V power supply
- Guaranteed monotonic by design over all codes
- Power-down to 50 nA at 3 V
- Reference derived from power supply
- Power-on reset to 0 V
- On-chip rail-to-rail output buffer amplifier
- 3 power-down functions

APPLICATIONS

- Portable battery-powered instruments
- Digital gain and offset adjustment
- Programmable voltage and current sources
- Programmable attenuators

GENERAL DESCRIPTION

The AD5301/AD5311/AD5321¹ are single 8-/10-/12-bit, buffered, voltage-output DACs that operate from a single 2.5 V to 5.5 V supply, consuming 120 μ A at 3 V. The on-chip output amplifier allows rail-to-rail output swing with a slew rate of 0.7 V/ μ s. It uses a 2-wire (I²C-compatible) serial interface that operates at clock rates up to 400 kHz. Multiple devices can share the same bus.

The reference for the DAC is derived from the power supply inputs and thus gives the widest dynamic output range. These devices incorporate a power-on reset circuit, which ensures that the DAC output powers up to 0 V and remains there until a valid write takes place. The devices contain a power-down feature that reduces the current consumption of the device to 50 nA at 3 V and provides software-selectable output loads while in power-down mode.

The low power consumption in normal operation makes these DACs ideally suited to portable battery-operated equipment. The power consumption is 0.75 mW at 5 V and 0.36 mW at 3 V, reducing to 1 μ W in all power-down modes.

FUNCTIONAL BLOCK DIAGRAM

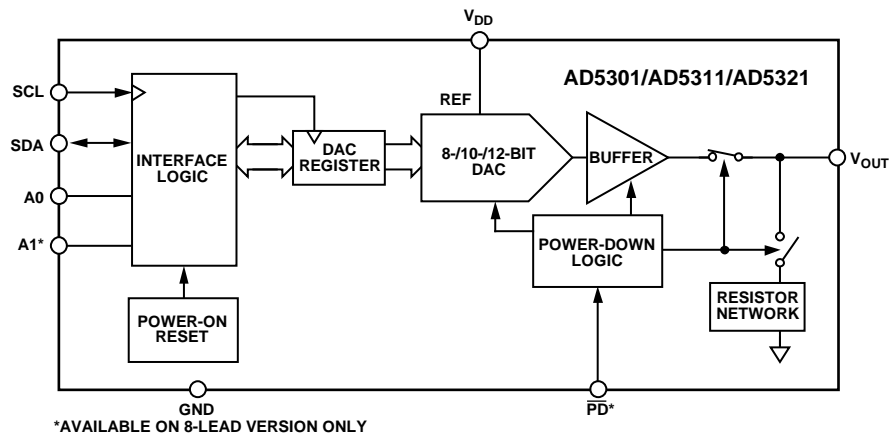

Figure 1.

¹ Protected by U.S. Patent No. 5684481.

Rev. C

Information furnished by Analog Devices is believed to be accurate and reliable. However, no responsibility is assumed by Analog Devices for its use, nor for any infringements of patents or other rights of third parties that may result from its use. Specifications subject to change without notice. No license is granted by implication or otherwise under any patent or patent rights of Analog Devices. Trademarks and registered trademarks are the property of their respective owners.

Document Feedback

TABLE OF CONTENTS

Features	1	Output Amplifier.....	13
Applications.....	1	Power-On Reset.....	13
General Description	1	Serial Interface	14
Functional Block Diagram	1	2-Wire Serial Bus.....	14
Revision History	2	Input Shift Register	14
Specifications.....	3	Write Operation.....	15
AC Characteristics.....	5	Read Operation.....	16
Timing Characteristics	5	Power-Down Modes	17
Absolute Maximum Ratings.....	6	Applications Notes	18
ESD Caution.....	6	Using the REF193/REF195 as a Power Supply	18
Pin Configurations and Function Descriptions	7	Bipolar Operation Using the AD5301/ AD5311/AD5321....	18
Terminology	8	Multiple Devices on One Bus	18
Typical Performance Characteristics	9	CMOS Driven SCL and SDA Lines.....	18
Theory of Operation	13	Power Supply Decoupling	19
Digital-to-Analog	13	Outline Dimensions	20
Resistor String.....	13	Ordering Guide	21

REVISION HISTORY

6/2016—Rev. B to Rev. C

Changes to Figure 33 and Figure 34.....	16
Changes to Ordering Guide	22

3/2007—Rev. A to Rev. B

Updated Format.....	Universal
Changes to Table 4.....	6
Changes to Figure 4 Caption.....	7
Updated Outline Dimensions	20
Changes to Ordering Guide	21

11/2003—Rev. 0 to Rev. A

Changes to Ordering Guide	4
Updated Outline Dimensions	15

7/1999—Revision 0: Initial Version

SPECIFICATIONS

$V_{DD} = 2.5\text{ V to }5.5\text{ V}$; $R_L = 2\text{ k}\Omega$ to GND; $C_L = 200\text{ pF}$ to GND; all specifications T_{MIN} to T_{MAX} , unless otherwise noted.

Table 1.

Parameter ²	B Version ¹			Unit	Test Conditions/Comments
	Min	Typ	Max		
DC PERFORMANCE ^{3,4}					
AD5301					
Resolution		8		Bits	Guaranteed monotonic by design over all codes.
Relative Accuracy		± 0.15	± 1	LSB	
Differential Nonlinearity		± 0.02	± 0.25	LSB	
AD5311					
Resolution		10		Bits	Guaranteed monotonic by design over all codes.
Relative Accuracy		± 0.5	± 4	LSB	
Differential Nonlinearity		± 0.05	± 0.5	LSB	
AD5321					
Resolution		12		Bits	Guaranteed monotonic by design over all codes.
Relative Accuracy		± 2	± 16	LSB	
Differential Nonlinearity		± 0.3	± 0.8	LSB	
Zero-Code Error		5	20	mV	All zeros loaded to DAC, see Figure 12.
Full-Scale Error		± 0.15	± 1.25	% of FSR	All ones loaded to DAC, see Figure 12.
Gain Error		± 0.15	± 1	% of FSR	
Zero-Code Error Drift ⁵		-20		$\mu\text{V}/^\circ\text{C}$	
Gain Error Drift ⁵		-5		ppm of FSR/ $^\circ\text{C}$	
OUTPUT CHARACTERISTICS ⁵					
Minimum Output Voltage		0.001		V	This is a measure of the minimum drive capability of the output amplifier.
Maximum Output Voltage		$V_{DD} - 0.001$		V	This is a measure of the maximum drive capability of the output amplifier.
DC Output Impedance		1		Ω	
Short-Circuit Current		50		mA	$V_{DD} = 5\text{ V}$.
		20		mA	$V_{DD} = 3\text{ V}$.
Power-Up Time		2.5		μs	Coming out of power-down mode. $V_{DD} = 5\text{ V}$.
		6		μs	Coming out of power-down mode. $V_{DD} = 3\text{ V}$.
LOGIC INPUTS (A0, A1, PD) ⁵					
Input Current			± 1	μA	
Input Low Voltage, V_{IL}			0.8	V	$V_{DD} = 5\text{ V} \pm 10\%$.
			0.6	V	$V_{DD} = 3\text{ V} \pm 10\%$.
			0.5	V	$V_{DD} = 2.5\text{ V}$.
Input High Voltage, V_{IH}	2.4			V	$V_{DD} = 5\text{ V} \pm 10\%$.
	2.1			V	$V_{DD} = 3\text{ V} \pm 10\%$.
	2.0			V	$V_{DD} = 2.5\text{ V}$.
Pin Capacitance		3		pF	
LOGIC INPUTS (SCL, SDA) ⁵					
Input High Voltage, V_{IH}	$0.7 \times V_{DD}$		$V_{DD} + 0.3$	V	$V_{IN} = 0\text{ V to }V_{DD}$.
Input Low Voltage, V_{IL}	-0.3		$+0.3 \times V_{DD}$	V	
Input Leakage Current, I_{IN}			± 1	μA	
Input Hysteresis, V_{HYST}	$0.05 \times V_{DD}$			V	
Input Capacitance, C_{IN}		6		pF	
Glitch Rejection ⁶			50	ns	

Parameter ²	B Version ¹			Unit	Test Conditions/Comments
	Min	Typ	Max		
LOGIC OUTPUT (SDA) ⁵					
Output Low Voltage, V_{OL}			0.4	V	$I_{SINK} = 3 \text{ mA}$.
			0.6	V	$I_{SINK} = 6 \text{ mA}$.
Three-State Leakage Current			± 1	μA	
Three-State Output Capacitance		6		pF	
POWER REQUIREMENTS					
V_{DD}	2.5		5.5	V	I_{DD} specification is valid for all DAC codes. DAC active and excluding load current.
I_{DD} (Normal Mode)					
$V_{DD} = 4.5 \text{ V to } 5.5 \text{ V}$		150	250	μA	$V_{IH} = V_{DD}$ and $V_{IL} = \text{GND}$.
$V_{DD} = 2.5 \text{ V to } 3.6 \text{ V}$		120	220	μA	$V_{IH} = V_{DD}$ and $V_{IL} = \text{GND}$.
I_{DD} (Power-Down Mode)					
$V_{DD} = 4.5 \text{ V to } 5.5 \text{ V}$		0.2	1	μA	$V_{IH} = V_{DD}$ and $V_{IL} = \text{GND}$.
$V_{DD} = 2.5 \text{ V to } 3.6 \text{ V}$		0.05	1	μA	$V_{IH} = V_{DD}$ and $V_{IL} = \text{GND}$.

¹ Temperature range is as follows: B Version: -40°C to $+105^{\circ}\text{C}$.

² See the Terminology section.

³ DC specifications tested with the outputs unloaded.

⁴ Linearity is tested using a reduced code range: AD5301 (Code 7 to 250); AD5311 (Code 28 to 1000); and AD5321 (Code 112 to 4000).

⁵ Guaranteed by design and characterization, not production tested.

⁶ Input filtering on both the SCL and SDA inputs suppress noise spikes that are less than 50 ns.

AC CHARACTERISTICS¹

$V_{DD} = 2.5\text{ V to }5.5\text{ V}$; $R_L = 2\text{ k}\Omega$ to GND; $C_L = 200\text{ pF}$ to GND; all specifications T_{MIN} to T_{MAX} , unless otherwise noted.

Table 2.

Parameter ³	B Version ²			Unit	Test Conditions/Comments
	Min	Typ	Max		
Output Voltage Settling Time					$V_{DD} = 5\text{ V}$
AD5301	6	8		μs	1/4 scale to 3/4 scale change (0x40 to 0xC0)
AD5311	7	9		μs	1/4 scale to 3/4 scale change (0x100 to 0x300)
AD5321	8	10		μs	1/4 scale to 3/4 scale change (0x400 to 0xC00)
Slew Rate	0.7			V/ μs	
Major-Code Change Glitch Impulse	12			nV-s	1 LSB change around major carry
Digital Feedthrough	0.3			nV-s	

¹ See the Terminology section.

² Temperature range for the B Version is as follows: -40°C to $+105^\circ\text{C}$.

³ Guaranteed by design and characterization, not production tested.

TIMING CHARACTERISTICS¹

$V_{DD} = 2.5\text{ V to }5.5\text{ V}$; all specifications T_{MIN} to T_{MAX} , unless otherwise noted.

Table 3.

Parameter ²	Limit at T_{MIN} , T_{MAX} , B Version	Unit	Test Conditions/Comments
f_{SCL}	400	kHz max	SCL clock frequency
t_1	2.5	μs min	SCL cycle time
t_2	0.6	μs min	t_{HIGH} , SCL high time
t_3	1.3	μs min	t_{LOW} , SCL low time
t_4	0.6	μs min	$t_{HD,STA}$, start/repeated start condition hold time
t_5	100	ns min	$t_{SU,DAT}$, data setup time
t_6^3	0.9	μs max	$t_{HD,DAT}$, data hold time
	0	μs min	
t_7	0.6	μs min	$t_{SU,STA}$, setup time for repeated start
t_8	0.6	μs min	$t_{SU,STO}$, stop condition setup time
t_9	1.3	μs min	t_{BUF} , bus free time between a stop condition and a start condition
t_{10}	300	ns max	t_R , rise time of both SCL and SDA when receiving ⁴
	0	ns min	May be CMOS driven
t_{11}	250	ns max	t_F , fall time of SDA when receiving ⁴
	300	ns max	t_F , fall time of both SCL and SDA when transmitting ⁴
C_b	$20 + 0.1C_b^5$	ns min	
	400	pF max	Capacitive load for each bus line

¹ See Figure 2.

² Guaranteed by design and characterization, not production tested.

³ A master device must provide a hold time of at least 300 ns for the SDA signal (refer to the $V_{IH,MIN}$ of the SCL signal) in order to bridge the undefined region of the falling edge of the SCL.

⁴ t_R and t_F measured between $0.3 V_{DD}$ and $0.7 V_{DD}$.

⁵ C_b is the total capacitance of one bus line in picofarads.

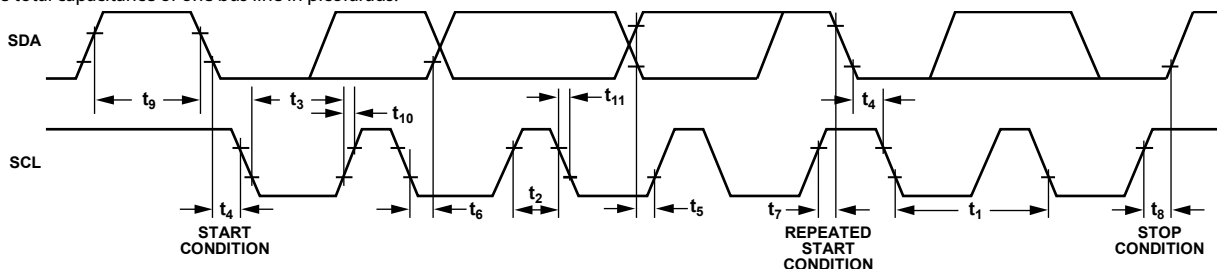

Figure 2. 2-Wire Serial Interface Timing Diagram

00927-002

ABSOLUTE MAXIMUM RATINGS

$T_A = 25^\circ\text{C}$, unless otherwise noted.¹

Table 4.

Parameter	Rating
V_{DD} to GND	-0.3 V to +7 V
SCL, SDA to GND	-0.3 V to $V_{DD} + 0.3$ V
\overline{PD} , A1, A0 to GND	-0.3 V to $V_{DD} + 0.3$ V
V_{OUT} to GND	-0.3 V to $V_{DD} + 0.3$ V
Operating Temperature Range	
Industrial (B Version)	-40°C to +105°C
Storage Temperature Range	-65°C to +150°C
Junction Temperature (T_J max)	150°C
SOT-23 Package	
Power Dissipation	$(T_J \text{ max} - T_A)/\theta_{JA}$
θ_{JA} Thermal Impedance	229.6°C/W
MSOP Package	
Power Dissipation	$(T_J \text{ max} - T_A)/\theta_{JA}$
θ_{JA} Thermal Impedance	206°C/W
Lead Temperature	JEDEC Industry Standard
Soldering	J-STD-020

¹Transient currents of up to 100 mA do not cause SCR latch-up.

Stresses at or above those listed under Absolute Maximum Ratings may cause permanent damage to the product. This is a stress rating only; functional operation of the product at these or any other conditions above those indicated in the operational section of this specification is not implied. Operation beyond the maximum operating conditions for extended periods may affect product reliability.

ESD CAUTION



ESD (electrostatic discharge) sensitive device. Charged devices and circuit boards can discharge without detection. Although this product features patented or proprietary protection circuitry, damage may occur on devices subjected to high energy ESD. Therefore, proper ESD precautions should be taken to avoid performance degradation or loss of functionality.

PIN CONFIGURATIONS AND FUNCTION DESCRIPTIONS

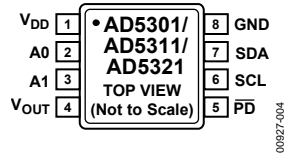

Figure 3. 8-Lead MSOP (RM-8) Pin Configuration

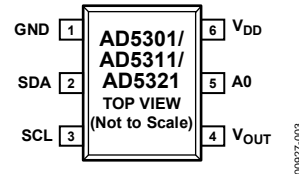

Figure 4. 6-Lead SOT-23 (RJ-6) Pin Configuration

Table 5. Pin Function Descriptions

Pin No.		Mnemonic	Description
MSOP	SOT-23		
1	6	V _{DD}	Power Supply Input. These parts can be operated from 2.5 V to 5.5 V and the supply should be decoupled with a 10 μ F in parallel with a 0.1 μ F capacitor to GND.
2	5	A0	Address Input. Sets the least significant bit of the 7-bit slave address.
3	Not applicable	A1	Address Input. Sets the second least significant bit of the 7-bit slave address.
4	4	V _{OUT}	Buffered Analog Output Voltage from the DAC. The output amplifier has rail-to-rail operation.
5	Not applicable	$\overline{\text{PD}}$	Active Low Control Input. Acts as a hardware power-down option. This pin overrides any software power-down option. The DAC output goes three-state and the current consumption of the part drops to 50 nA at 3 V (200 nA at 5 V).
6	3	SCL	Serial Clock Line. This is used in conjunction with the SDA line to clock data into the 16-bit input shift register. Clock rates of up to 400 kbps can be accommodated in the I ² C-compatible interface. SCL may be CMOS/TTL driven.
7	2	SDA	Serial Data Line. This is used in conjunction with the SCL line to clock data into the 16-bit input shift register during the write cycle and to read back one or two bytes of data (one byte for the AD5301 , two bytes for the AD5311/AD5321) during the read cycle. It is a bidirectional open-drain data line that should be pulled to the supply with an external pull-up resistor. If not used in readback mode, SDA may be CMOS/TTL driven.
8	1	GND	Ground Reference Point for All Circuitry on the Device.

TERMINOLOGY

Relative Accuracy

For the DAC, relative accuracy or integral nonlinearity (INL) is a measure of the maximum deviation, in LSBs, from a straight line passing through the actual endpoints of the DAC transfer function. Typical INL vs. code plots can be seen in Figure 5 to Figure 7.

Differential Nonlinearity (DNL)

DNL is the difference between the measured change and the ideal 1 LSB change between any two adjacent codes. A specified differential nonlinearity of ± 1 LSB maximum ensures monotonicity. These DACs are guaranteed monotonic by design over all codes. Typical DNL vs. code plots can be seen in Figure 8 to Figure 10.

Zero-Code Error

Zero-code error is a measure of the output error when zero code (0x00) is loaded to the DAC register. Ideally, the output should be 0 V. The zero-code error of the [AD5301/AD5311/AD5321](#) is always positive because the output of the DAC cannot go below 0 V, due to a combination of the offset errors in the DAC and output amplifier. It is expressed in millivolts (see Figure 12).

Full-Scale Error (FSR)

Full-scale error is a measure of the output error when full scale is loaded to the DAC register. Ideally, the output should be $V_{DD} - 1$ LSB. Full-scale error is expressed in percent of FSR. A plot can be seen in Figure 12.

Gain Error

Gain error is a measure of the span error of the DAC. It is the deviation in slope of the actual DAC transfer characteristic from the ideal expressed as a percentage of the full-scale range.

Zero-Code Error Drift

Zero-code error drift is a measure of the change in zero-code error with a change in temperature. It is expressed in $\mu\text{V}/^\circ\text{C}$.

Gain Error Drift

Gain error drift is a measure of the change in gain error with changes in temperature. It is expressed in (ppm of full-scale range)/ $^\circ\text{C}$.

Major Code Transition Glitch Energy

Major code transition glitch energy is the energy of the impulse injected into the analog output when the code in the DAC register changes state. It is normally specified as the area of the glitch in nV-s and is measured when the digital code is changed by 1 LSB at the major carry transition (011 . . . 11 to 100 . . . 00 or 100 . . . 00 to 011 . . . 11).

Digital Feedthrough

Digital feedthrough is a measure of the impulse injected into the analog output of the DAC from the digital input pins of the device, but is measured when the DAC is not being written to. It is specified in nV-s and is measured with a full-scale change on the digital input pins, that is, from all 0s to all 1s and vice versa.

TYPICAL PERFORMANCE CHARACTERISTICS

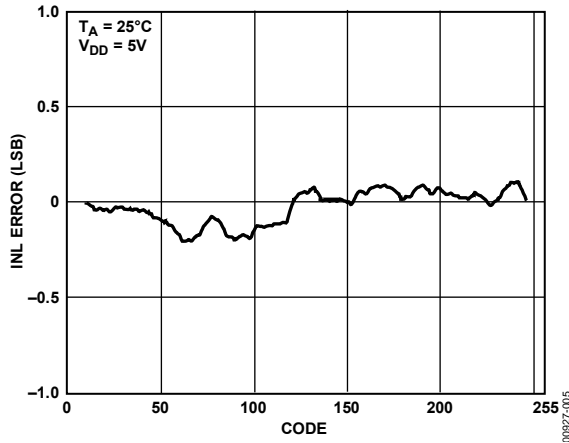

Figure 5. AD5301 Typical INL Plot



Figure 8. AD5301 Typical DNL Plot

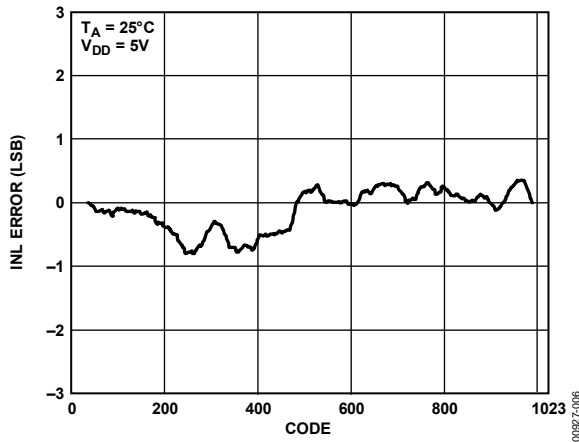

Figure 6. AD5311 Typical INL Plot

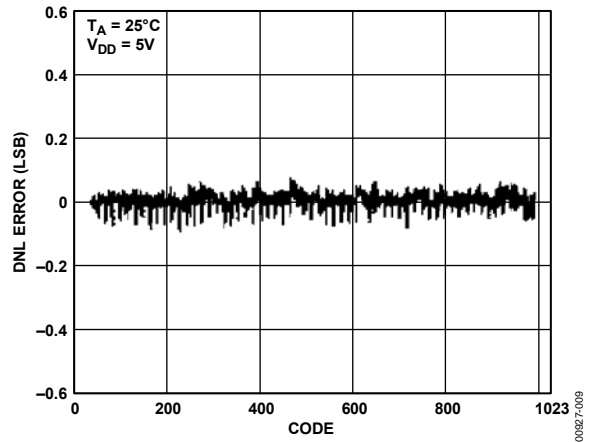

Figure 9. AD5311 Typical DNL Plot

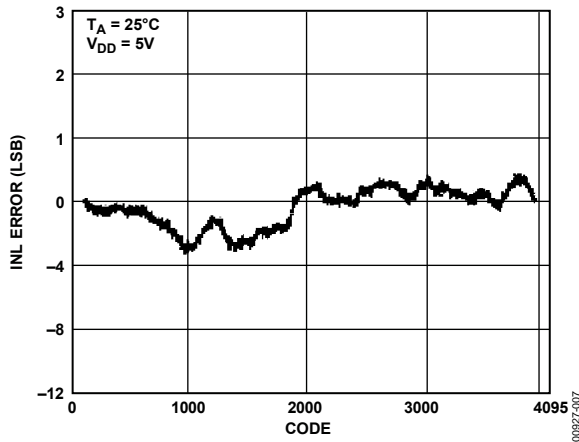

Figure 7. AD5321 Typical INL Plot

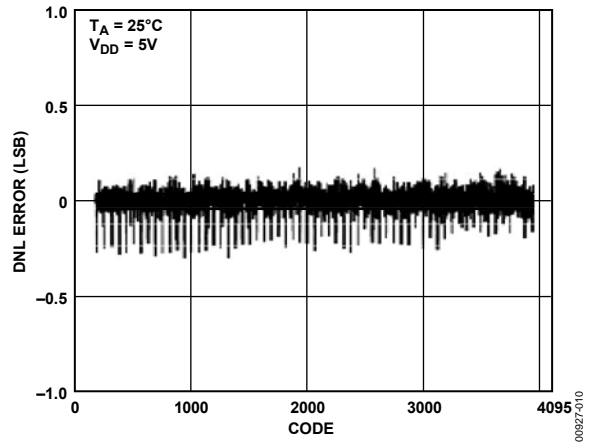

Figure 10. AD5321 Typical DNL Plot



Figure 11. AD5301 INL Error and DNL Error vs. Temperature

00927-011

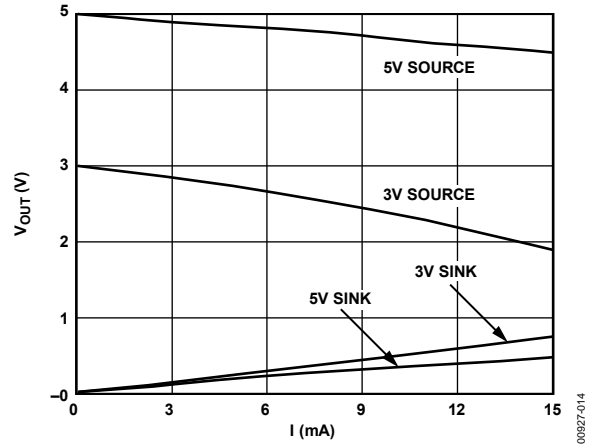

Figure 14. Source and Sink Current Capability

00927-014

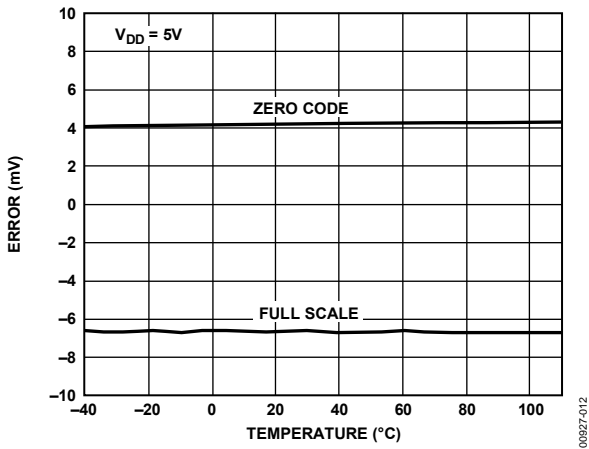

Figure 12. Zero-Code Error and Full-Scale Error vs. Temperature

00927-012

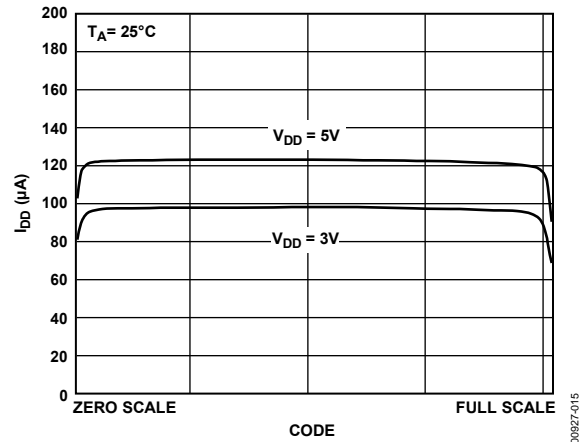

Figure 15. Supply Current vs. Code

00927-015

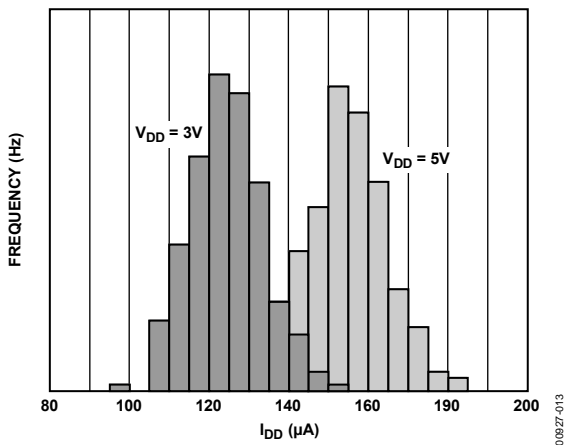

Figure 13. I_{DD} Histogram with $V_{DD} = 3V$ and $V_{DD} = 5V$

00927-013

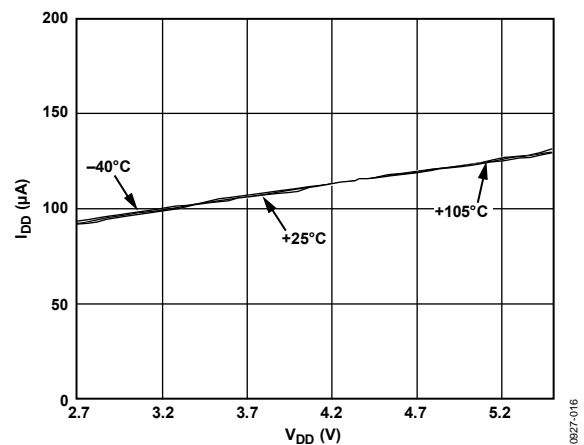

Figure 16. Supply Current vs. Supply Voltage

00927-016

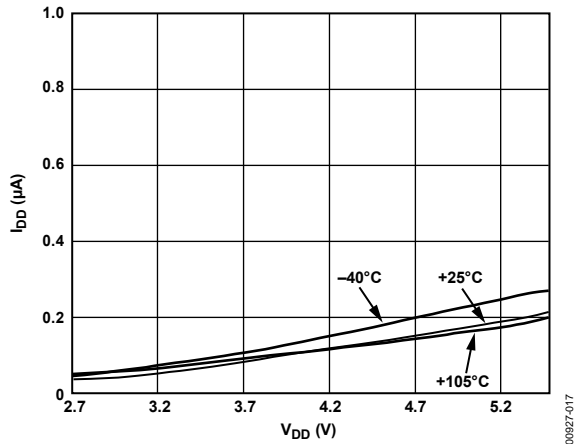

Figure 17. Power-Down Current vs. Supply Voltage

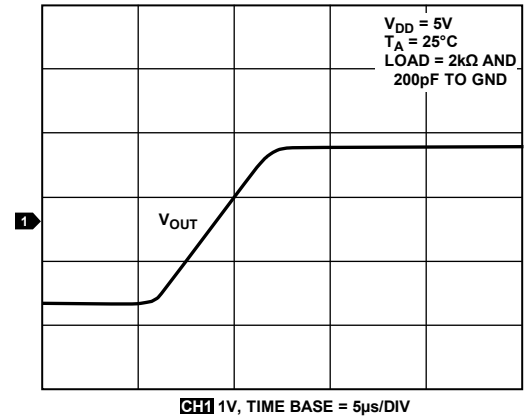

Figure 19. Half-Scale Settling (1/4 to 3/4 Scale Code Charge)

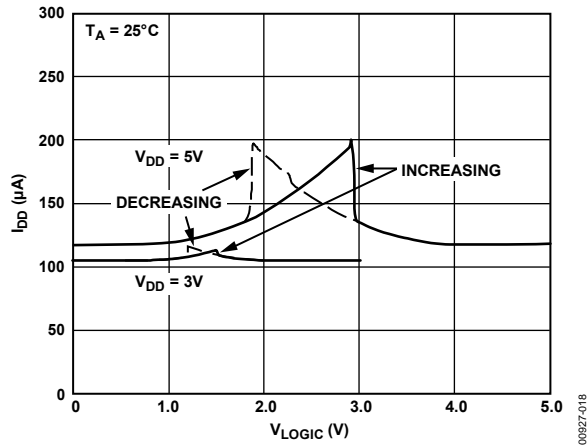

Figure 18. Supply Current vs. Logic Input Voltage for SDA and SCL Voltage Increasing and Decreasing

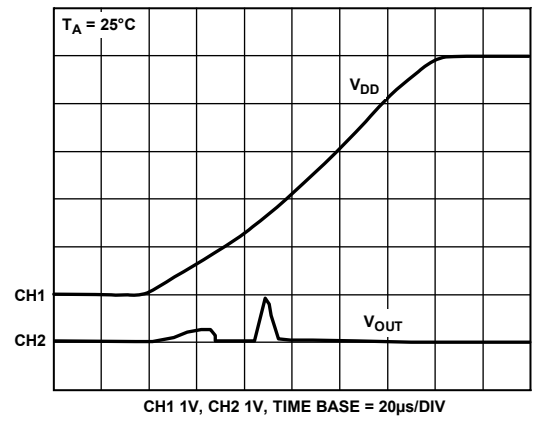

Figure 20. Power-On Reset to 0 V

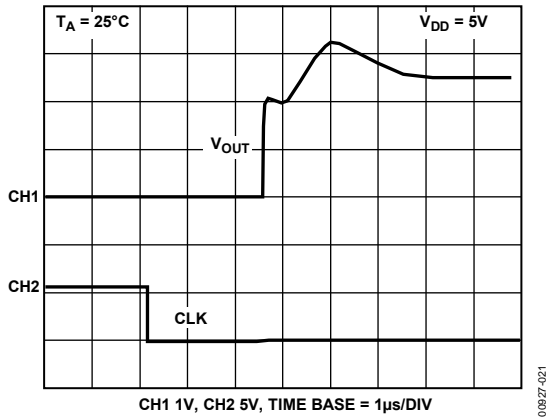

Figure 21. Exiting Power-Down to Midscale

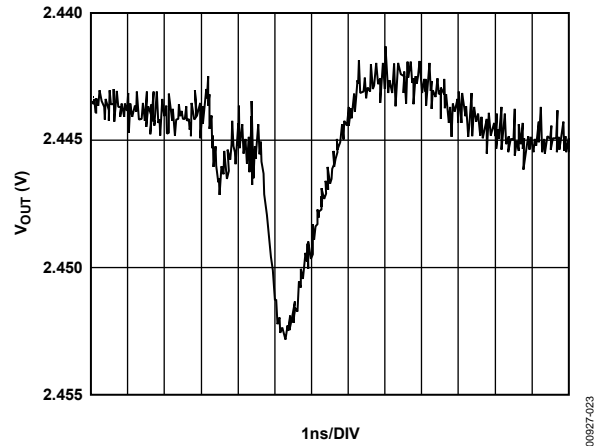

Figure 23. Digital Feedthrough

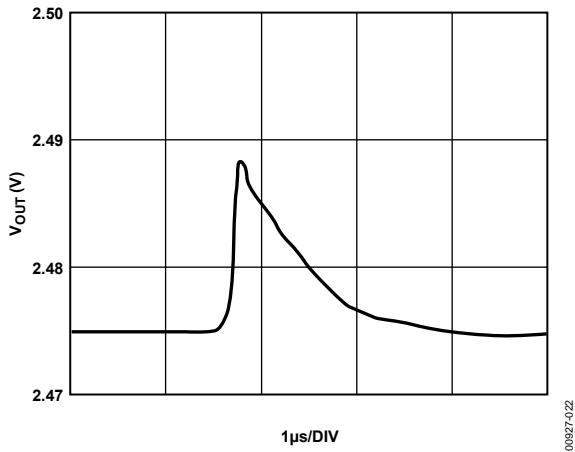

Figure 22. Major-Code Transition

THEORY OF OPERATION

The [AD5301/AD5311/AD5321](#) are single resistor-string DACs fabricated on a CMOS process with resolutions of 8/10/12 bits, respectively. Data is written via a 2-wire serial interface. The devices operate from single supplies of 2.5 V to 5.5 V and the output buffer amplifiers provide rail-to-rail output swing with a slew rate of 0.7 V/ μ s. The power supply (V_{DD}) acts as the reference to the DAC. The [AD5301/AD5311/AD5321](#) have three programmable power-down modes, in which the DAC can be turned off completely with a high impedance output, or the output can be pulled low by an on-chip resistor (see the Power-Down Modes section).

DIGITAL-TO-ANALOG

The architecture of the DAC channel consists of a resistor string DAC followed by an output buffer amplifier. The voltage at the V_{DD} pin provides the reference voltage for the DAC. Figure 24 shows a block diagram of the DAC architecture. Since the input coding to the DAC is straight binary, the ideal output voltage is given by

$$V_{OUT} = \frac{V_{DD} \times D}{2^N}$$

where:

N = DAC resolution.

D = decimal equivalent of the binary code that is loaded to the DAC register:

0–255 for [AD5301](#) (8 bits)

0–1023 for [AD5311](#) (10 bits)

0–4095 for [AD5321](#) (12 bits).

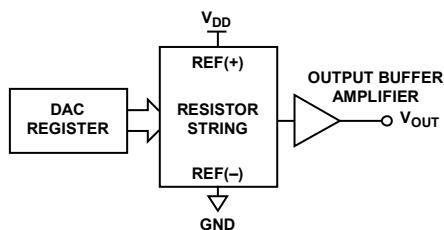

Figure 24. DAC Channel Architecture

RESISTOR STRING

The resistor string section is shown in Figure 25. It is simply a string of resistors, each with a value of R . The digital code loaded to the DAC register determines at what node on the string the voltage is tapped off to be fed into the output amplifier. The voltage is tapped off by closing one of the switches connecting the string to the amplifier. Because it is a string of resistors, it is guaranteed monotonic over all codes.

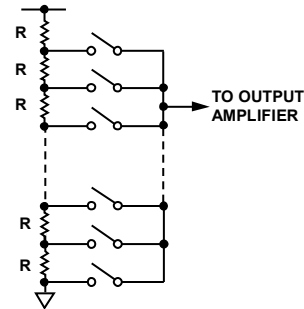

Figure 25. Resistor String

OUTPUT AMPLIFIER

The output buffer amplifier is capable of generating output voltages to within 1 mV from either rail, which gives an output range of 0.001 V to $V_{DD} - 0.001$ V. It is capable of driving a load of 2 k Ω to GND and V_{DD} , in parallel with 500 pF to GND. The source and sink capabilities of the output amplifier can be seen in Figure 14.

The slew rate is 0.7 V/ μ s with a half-scale settling time to ± 0.5 LSB (at 8 bits) of 6 μ s with the output unloaded.

POWER-ON RESET

The [AD5301/AD5311/AD5321](#) are provided with a power-on reset function, ensuring that they power up in a defined state.

The DAC register is filled with zeros and remains so until a valid write sequence is made to the device. This is particularly useful in applications where it is important to know the state of the DAC output while the device is powering up.

SERIAL INTERFACE

2-WIRE SERIAL BUS

The AD5301/AD5311/AD5321 are controlled via an I²C-compatible serial bus. The DACs are connected to this bus as slave devices (no clock is generated by the AD5301/AD5311/AD5321 DACs).

The AD5301/AD5311/AD5321 has a 7-bit slave address. In the case of the 6-lead device, the six MSBs are 000110 and the LSB is determined by the state of the A0 pin. In the case of the 8-lead device, the five MSBs are 00011 and the two LSBs are determined by the state of the A0 and A1 pins. A1 and A0 allow the user to use up to four of these DACs on one bus.

The 2-wire serial bus protocol operates as follows:

1. The master initiates data transfer by establishing a start condition, which is when a high-to-low transition on the SDA line occurs while SCL is high. The following byte is the address byte that consists of the 7-bit slave address followed by an R/W bit (this bit determines whether data is read from or written to the slave device).
2. The slave whose address corresponds to the transmitted address responds by pulling the SDA line low during the ninth clock pulse (this is termed the acknowledge bit). At this stage, all other devices on the bus remain idle while the selected device waits for data to be written to or read from its serial register. If the R/W bit is high, the master reads from the slave device. However, if the R/W bit is low, the master writes to the slave device.
3. Data is transmitted over the serial bus in sequences of nine clock pulses (eight data bits followed by an acknowledge bit). The transitions on the SDA line must occur during the low period of SCL and remain stable during the high period of SCL.
4. When all data bits have been read or written, a stop condition is established by the master. A stop condition is defined as a low-to-high transition on the SDA line while

SCL is high. In write mode, the master pulls the SDA line high during the 10th clock pulse to establish a stop condition. In read mode, the master issues a no acknowledge for the ninth clock pulse (that is, the SDA line remains high). The master then brings the SDA line low before the 10th clock pulse and then high during the 10th clock pulse to establish a stop condition.

In the case of the AD5301/AD5311/AD5321, a write operation contains two bytes whereas a read operation may contain one or two bytes. See Figure 29 to Figure 34 for a graphical explanation of the serial interface.

A repeated write function gives the user flexibility to update the DAC output a number of times after addressing the device only once. During the write cycle, each multiple of two data bytes updates the DAC output. For example, after the DAC acknowledges its address byte, and receives two data bytes; the DAC output updates after the two data bytes, if another two data bytes are written to the DAC while it is still the addressed slave device. These data bytes also cause an output update. A repeat read of the DAC is also allowed.

INPUT SHIFT REGISTER

The input shift register is 16 bits wide. Figure 26, Figure 27, and Figure 28 illustrate the contents of the input shift register for each device. Data is loaded into the device as a 16-bit word under the control of a serial clock input, SCL. The timing diagram for this operation is shown in Figure 2. The 16-bit word consists of four control bits followed by 8/10/12 bits of data, depending on the device type. MSB (Bit 15) is loaded first. The first two bits are don't cares. The next two are control bits that control the mode of operation of the device (normal mode or any one of three power-down modes). See the Power-Down Modes section for a complete description. The remaining bits are left justified DAC data bits, starting with the MSB and ending with the LSB.

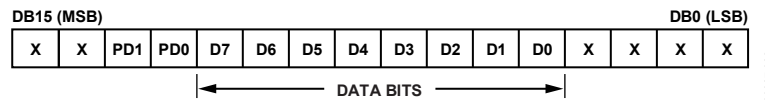

Figure 26. AD5301 Input Shift Register Contents

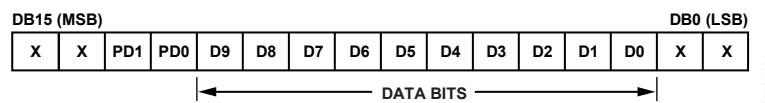

Figure 27. AD5311 Input Shift Register Contents

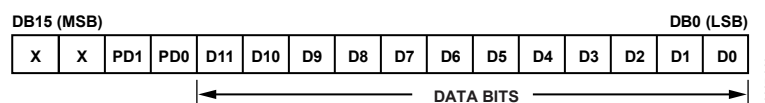

Figure 28. AD5321 Input Shift Register Contents

WRITE OPERATION

When writing to the AD5301/AD5311/AD5321 DACs, the user must begin with an address byte, after which the DAC acknowledges that it is prepared to receive data by pulling

SDA low. This address byte is followed by the 16-bit word in the form of two control bytes. The write operations for the three DACs are shown in Figure 29 to Figure 31.

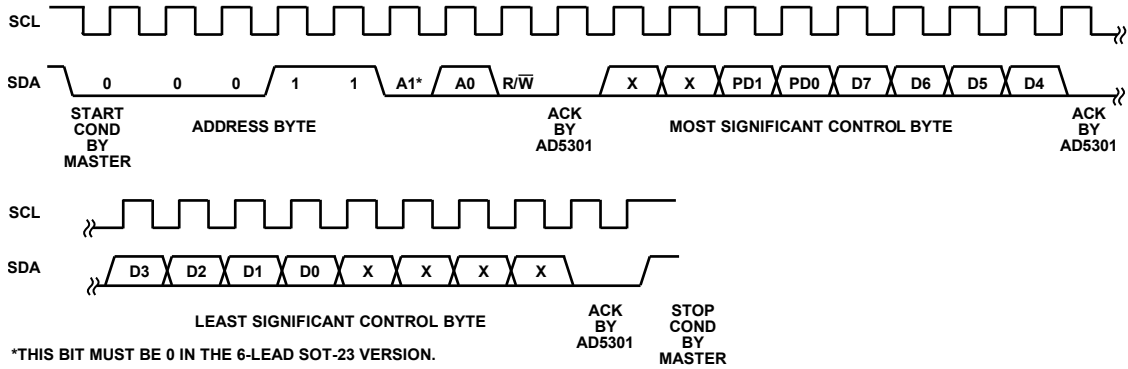

Figure 29. AD5301 Write Sequence

00927-027

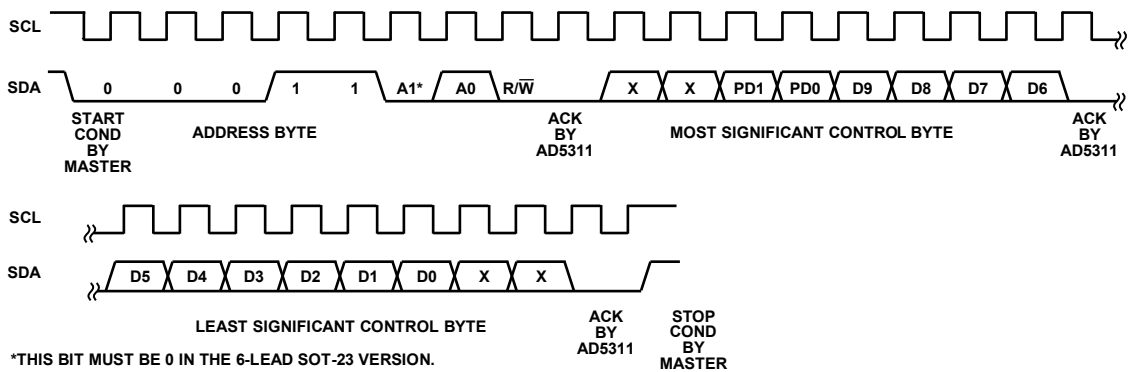

Figure 30. AD5311 Write Sequence

00927-028

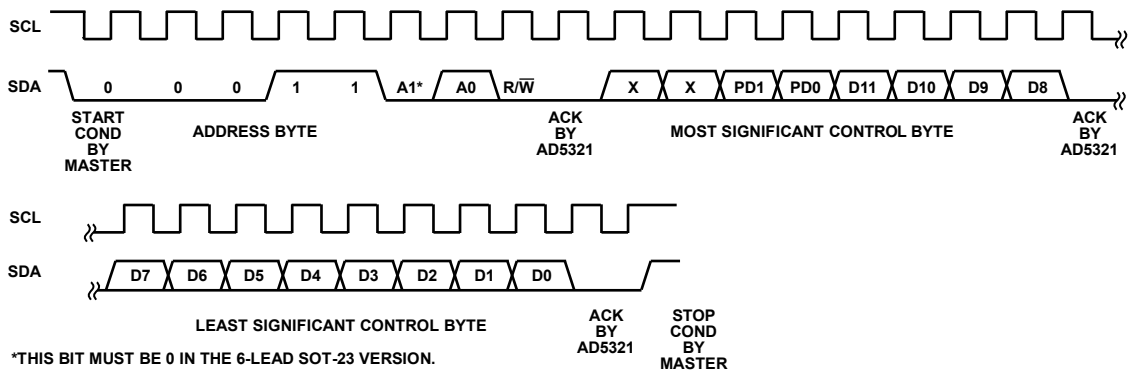

Figure 31. AD5321 Write Sequence

00927-029

READ OPERATION

When reading data back from the [AD5301/AD5311/AD5321](#) DACs, the user must begin with an address byte after which the DAC acknowledges that it is prepared to transmit data by pulling SDA low. There are two different read operations. In the case of the [AD5301](#), the readback is a single byte that consists of

the eight data bits in the DAC register. However, in the case of the [AD5311](#) and [AD5321](#), the readback consists of two bytes that contain both the data and the power-down mode bits. The read operations for the three DACs are shown in Figure 32 to Figure 34.

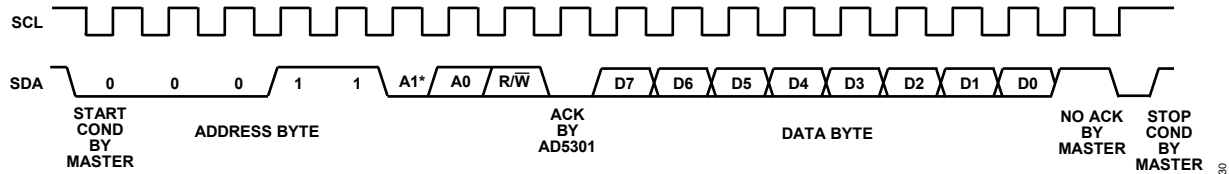

*THIS BIT MUST BE 0 IN THE 6-LEAD SOT-23 VERSION.

Figure 32. [AD5301](#) Readback Sequence

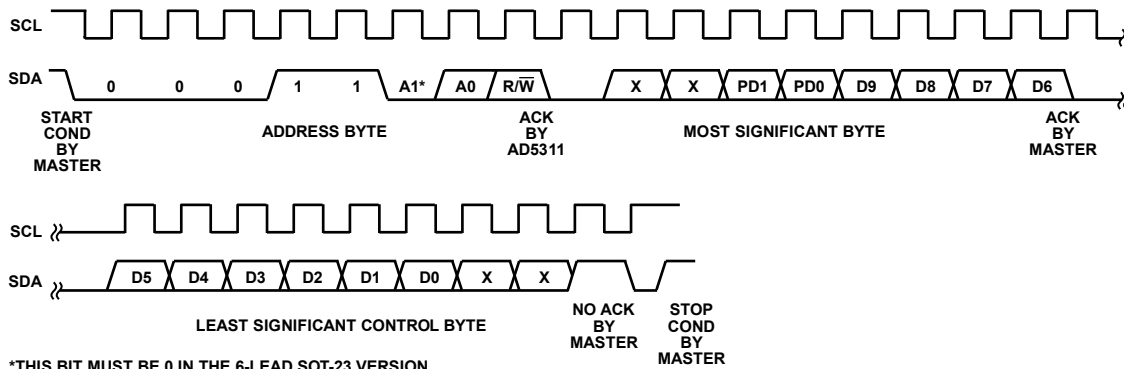

*THIS BIT MUST BE 0 IN THE 6-LEAD SOT-23 VERSION.

Figure 33. [AD5311](#) Readback Sequence

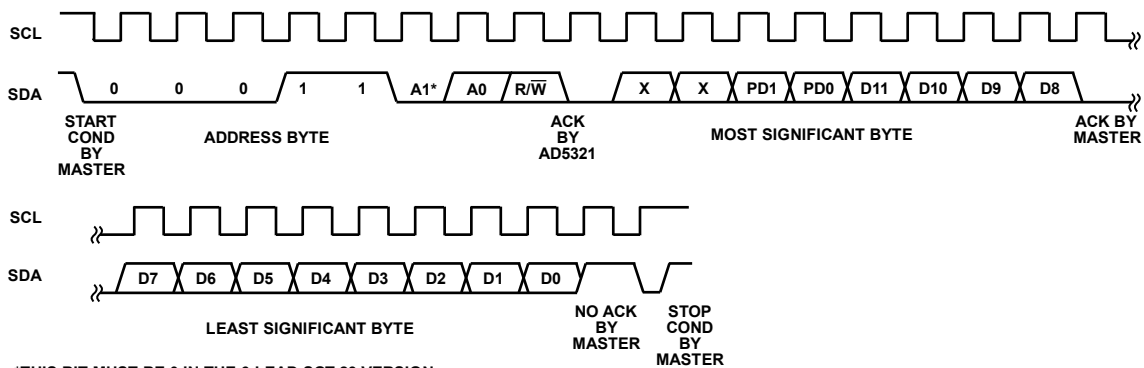

*THIS BIT MUST BE 0 IN THE 6-LEAD SOT-23 VERSION.

Figure 34. [AD5321](#) Readback Sequence

POWER-DOWN MODES

The AD5301/AD5311/AD5321 have very low power consumption, dissipating typically 0.36 mW with a 3 V supply and 0.75 mW with a 5 V supply. Power consumption can be further reduced when the DAC is not in use by putting it into one of three power-down modes, which are selected by Bit 13 and Bit 12 (PD1 and PD0) of the control word. Table 6 shows how the state of the bits corresponds to the mode of operation of the DAC.

Table 6. PD1 and PD0 Operating Modes

PD1	PD0	Operating Mode
0	0	Normal operation
0	1	Power-down (1 k Ω load to GND)
1	0	Power-down (100 k Ω load to GND)
1	1	Power-down (three-state output)

The software power-down modes programmed by PD1 and PD0 may be overridden by the PD pin on the 8-lead version. Taking this pin low puts the DAC into three-state power-down mode. If PD is not used, tie it high.

When both bits are set to 0, the DAC works normally with its normal power consumption of 150 μ A at 5 V, while for the three power-down modes, the supply current falls to 200 nA at 5 V (50 nA at 3 V). Not only does the supply current drop, but the

output stage is also internally switched from the output of the amplifier to a resistor network of known values. This has the advantage that the output impedance of the device is known while the device is in power-down mode and provides a defined input condition for whatever is connected to the output of the DAC amplifier. There are three different options. The output is connected internally to GND through a 1 k Ω resistor, a 100 k Ω resistor, or it is left three-stated. Resistor tolerance = $\pm 20\%$. The output stage is illustrated in Figure 35.

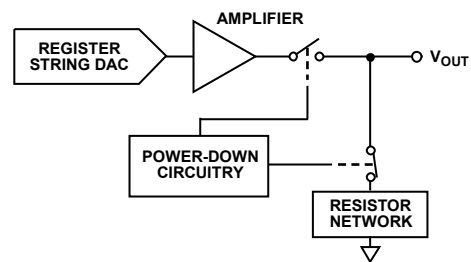

Figure 35. Output Stage During Power-Down

The bias generator, the output amplifier, the resistor string, and all other associated linear circuitry are shut down when the power-down mode is activated. However, the contents of the DAC register are unchanged when in power-down. The time to exit power-down is typically 2.5 μ s for $V_{DD} = 5$ V and 6 μ s when $V_{DD} = 3$ V (see Figure 21).

APPLICATIONS NOTES

USING THE REF193/REF195 AS A POWER SUPPLY

Because the supply current required by the AD5301/AD5311/AD5321 is extremely low, the user has an alternative option to employ a REF195 voltage reference (for 5 V) or a REF193 voltage reference (for 3 V) to supply the required voltage to the device (see Figure 36).

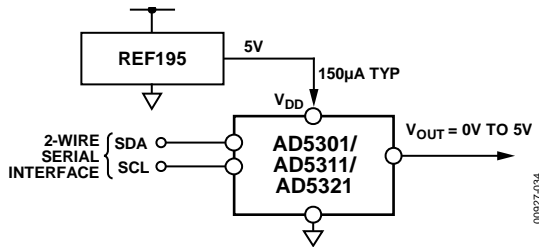

Figure 36. REF195 as Power Supply to AD5301/AD5311/AD5321

This is especially useful if the power supply is quite noisy or if the system supply voltages are at some value other than 5 V or 3 V (for example, 15 V). The REF193/REF195 output a steady supply voltage for the AD5301/AD5311/AD5321. If the low dropout REF195 is used, it needs to supply a current of 150 µA to the AD5301/AD5311/AD5321. This is with no load on the output of the DAC. When the DAC output is loaded, the REF195 also needs to supply the current to the load.

The total current required (with a 2 kΩ load on the DAC output and full scale loaded to the DAC) is

$$150 \mu\text{A} + (5 \text{ V} / 2 \text{ k}\Omega) = 2.65 \text{ mA}$$

The load regulation of the REF195 is typically 2 ppm/mA, which results in an error of 5.3 ppm (26.5 µV) for the 2.65 mA current drawn from it. This corresponds to a 0.00136 LSB error.

BIPOLAR OPERATION USING THE AD5301/AD5311/AD5321

The AD5301/AD5311/AD5321 has been designed for single-supply operation, but a bipolar output range is also possible using the circuit in Figure 37. The circuit below gives an output voltage range of ±5 V. Rail-to-rail operation at the amplifier output is achievable using an AD820 or an OP295 as the output amplifier.

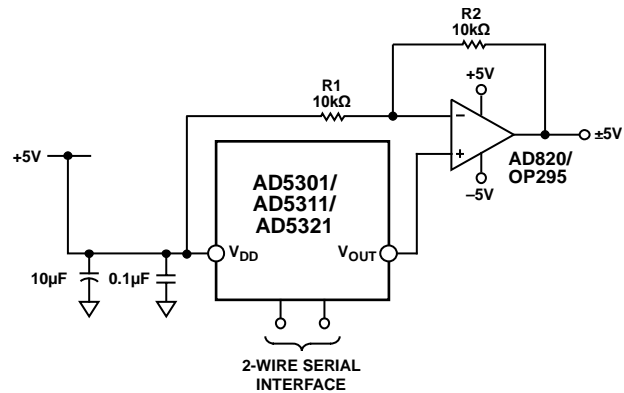

Figure 37. Bipolar Operation with the AD5301/AD5311/AD5321

The output voltage for any input code can be calculated as

$$V_{OUT} = ((V_{DD} \times (D/2^N) \times R1 + R2)/R1) - V_{DD} \times (R2/R1))$$

where:

D is the decimal equivalent of the code loaded to the DAC.

N is the DAC resolution.

With $V_{DD} = 5 \text{ V}$, $R1 = R2 = 10 \text{ k}\Omega$,

$$V_{OUT} = (10 \times D/2^N) - 5 \text{ V}$$

MULTIPLE DEVICES ON ONE BUS

Figure 38 shows four AD5301 devices on the same serial bus. Each has a different slave address since the state of their A0 and A1 pins is different. This allows each DAC to be written to or read from independently. The master device output bus line drivers are open-drain, pull-downs in a fully I²C-compatible interface.

CMOS DRIVEN SCL AND SDA LINES

For single or multisupply systems where the minimum SCL swing requirements allow it, a CMOS SCL driver may be used, and the SCL pull-up resistor can be removed, making the SCL bus line fully CMOS compatible. This reduces power consumption in both the SCL driver and receiver devices. The SDA line remains open-drain, I²C compatible.

Further changes, in the SDA line driver, may be made to make the system more CMOS compatible and save more power. As the SDA line is bidirectional, it cannot be made fully CMOS compatible. A switched pull-up resistor can be combined with a CMOS device with an open-circuit (three-state) input such that the CMOS SDA driver is enabled during write cycles and I²C mode is enabled during shared cycles, that is, readback, acknowledge bit cycles, start conditions, and stop conditions.

POWER SUPPLY DECOUPLING

In any circuit where accuracy is important, careful consideration of the power supply and ground return layout helps to ensure the rated performance. The [AD5301/AD5311/AD5321](#) should be decoupled to GND with 10 μF in parallel with a 0.1 μF capacitor, located as close to the package as possible. The 10 μF capacitor should be the tantalum bead type, while a ceramic 0.1 μF capacitor provides a sufficient low impedance path to

ground at high frequencies. The power supply lines of the [AD5301/AD5311/AD5321](#) should use as large a trace as possible to provide low impedance paths. A ground line routed between the SDA and SCL lines helps reduce crosstalk between them. This is not required on a multilayer board as there is a ground plane layer, but separating the lines helps.

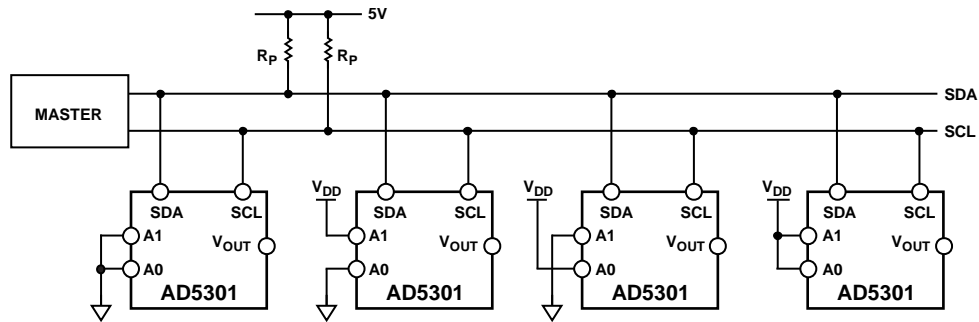
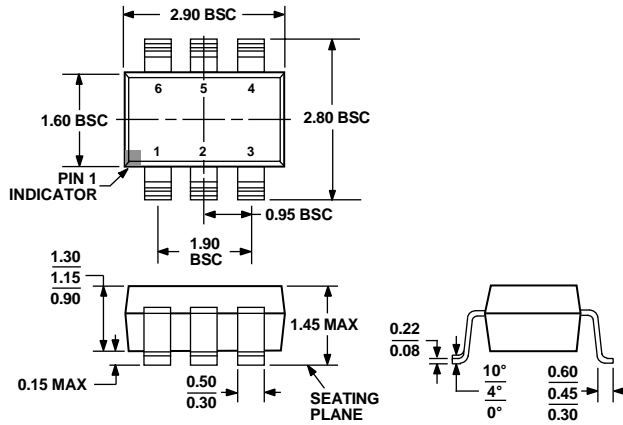

Figure 38. Multiple [AD5301](#) Devices on One Bus

00927-036

OUTLINE DIMENSIONS



COMPLIANT TO JEDEC STANDARDS MO-178-AB

Figure 39. 6-Lead Small Outline Transistor Package [SOT-23] (RJ-6)

Dimensions shown in millimeters

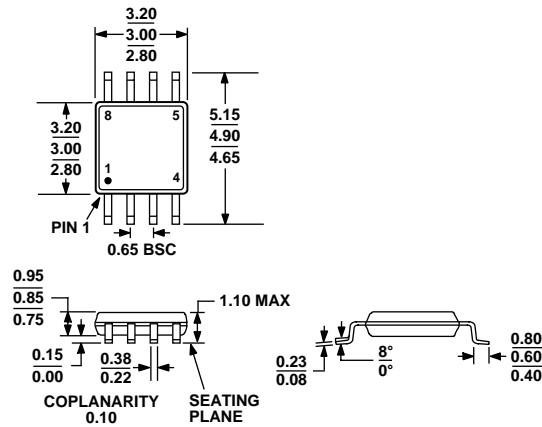

COMPLIANT TO JEDEC STANDARDS MO-187-AA

Figure 40. 8-Lead Mini Small Outline Package [MSOP] (RM-8)

Dimensions shown in millimeters

ORDERING GUIDE

Model ¹	Temperature Range	Package Description	Package Option	Branding
AD5301BRMZ	-40°C to +105°C	8-Lead Mini Small Outline Package [MSOP]	RM-8	D8B
AD5301BRMZ-REEL7	-40°C to +105°C	8-Lead Mini Small Outline Package [MSOP]	RM-8	D8B
AD5301BRTZ-500RL7	-40°C to +105°C	6-Lead Small Outline Transistor Package [SOT-23]	RJ-6	D8B
AD5301BRTZ-REEL7	-40°C to +105°C	6-Lead Small Outline Transistor Package [SOT-23]	RJ-6	D8B
AD5311BRMZ	-40°C to +105°C	8-Lead Mini Small Outline Package [MSOP]	RM-8	D9B
AD5311BRMZ-REEL	-40°C to +105°C	8-Lead Mini Small Outline Package [MSOP]	RM-8	D9B
AD5311BRMZ-REEL7	-40°C to +105°C	8-Lead Mini Small Outline Package [MSOP]	RM-8	D9B
AD5311BRTZ-500RL7	-40°C to +105°C	6-Lead Small Outline Transistor Package [SOT-23]	RJ-6	D9B
AD5311BRTZ-REEL7	-40°C to +105°C	6-Lead Small Outline Transistor Package [SOT-23]	RJ-6	D9B
AD5321BRM	-40°C to +105°C	8-Lead Mini Small Outline Package [MSOP]	RM-8	DAB
AD5321BRM-REEL7	-40°C to +105°C	8-Lead Mini Small Outline Package [MSOP]	RM-8	DAB
AD5321BRMZ	-40°C to +105°C	8-Lead Mini Small Outline Package [MSOP]	RM-8	DAB
AD5321BRMZ-REEL	-40°C to +105°C	8-Lead Mini Small Outline Package [MSOP]	RM-8	DAB
AD5321BRMZ-REEL7	-40°C to +105°C	8-Lead Mini Small Outline Package [MSOP]	RM-8	DAB
AD5321BRTZ-500RL7	-40°C to +105°C	6-Lead Small Outline Transistor Package [SOT-23]	RJ-6	DAB
AD5321BRTZ-REEL7	-40°C to +105°C	6-Lead Small Outline Transistor Package [SOT-23]	RJ-6	DAB

¹ Z = RoHS Compliant Part.

NOTES

NOTES

NOTES

I²C refers to a communications protocol originally developed by Philips Semiconductors (now NXP Semiconductors).

©1999–2016 Analog Devices, Inc. All rights reserved. Trademarks and registered trademarks are the property of their respective owners.
D00927-0-6/16(C)



www.analog.com

Looking for pricing, stock, or lifecycle information?

Click below to explore more details on WIN SOURCE:

- ⊖ [View AD5301BRT-500RL7 on WIN SOURCE](#)
- ⊖ [Analog Devices Inc. Information](#)

Optimize Your Supply Chain with WIN SOURCE Solutions

- ✓ Global Sourcing Solution
- ✓ Obsolete Management
- ✓ Cost Control Management
- ✓ Shortage Management
- ✓ Alternative Solution
- ✓ Excess Inventory Management