



**THE DATASHEET OF
GC5337IZEV**



Wideband Transmit-Receive Digital Signal Processors

Check for Samples: [GC5330](#), [GC5337](#)

FEATURES

- Integrated Transmit and Receive Digital IF Solution
- Up to 4 TX, 8 RX, Plus DPD Feedback
- TX-Transmit Includes DUC, CFR, DPD, TX Equalizer, and Bulk Upconverter
- 62-MHz TX Signal Bandwidth With Fifth-Order DPD Correction
- CFR: 6-dB PAR for WCDMA, 7-dB LTE Signals With EVM Meeting 3GPP Specs; Configurable for All Major Wireless Infrastructure Standards
- DPD: Memory Compensation, Typical ACLR Improvement of 20 dB or More
- RX-Receive Includes DC-Offset Cancellation, Front-End and Back-End AGC, Bulk Downconverter, RX Equalizer, I/Q Imbalance Correction, DDC
- 4 DDUCs, 1–12 Channels per DDUC, Each DDUC Can Be Programmed to TX or RX, at a Common Resampler Rate – Multimode Support
- Seamless Interface to TI High-Speed Data Converters
- 4 TX Aggregate Output to DACs up to 930 MSPS Complex
- 8 RX Aggregate Input From ADCs up to 1.24 GSPS Real
- Supports Envelope Tracking Techniques
- 16-Tap (Complex) RX Equalizers
- Two 4K Complex Word Capture Buffers for Signal Analysis, Adaptive Filtering, and DPD Algorithms
- TMS320C6748 DPD Optimization Software
- 1.1-V Core, 3.3-V I/O CMOS, 1.8-V I/O LVDS
- Power Consumption, 3.5 W Typical
- 484-Ball TE-PBGA Package, 23 mm × 23 mm

APPLICATIONS

- Multi-Standard Base Stations
- 3GPP (LTE, W-CDMA, TDS-CDMA)
- MC-GSM
- WiMAX and WiBro (OFDMA)
- Multi-Carrier Power Amplifiers (MCPAs)
- Wireless Infrastructure Repeaters
- Up to 4 × 4 MIMO

DESCRIPTION

The GC533x is a wideband transmit and receive signal processor that includes digital downconverter / upconverter (DDUC), transmit, receive, and capture buffer blocks. The transmit path includes crest factor reduction (CFR), digital predistortion (DPD) and associated feedback path, complex equalization, and bulk upconversion.

The receive path includes wideband and narrowband automatic gain control (AGC), bulk downconversion, complex equalization, and I/Q imbalance correction.

The DDUC section consists of four identical DDUC blocks, each supporting up to 12 channels. Each channel has independent fractional resamplers and NCOs to enable flexible carrier configurations. Multi-mode/multi-standard operation can be supported by configuring the individual DDUC blocks to different filtering and oversampling scenarios.

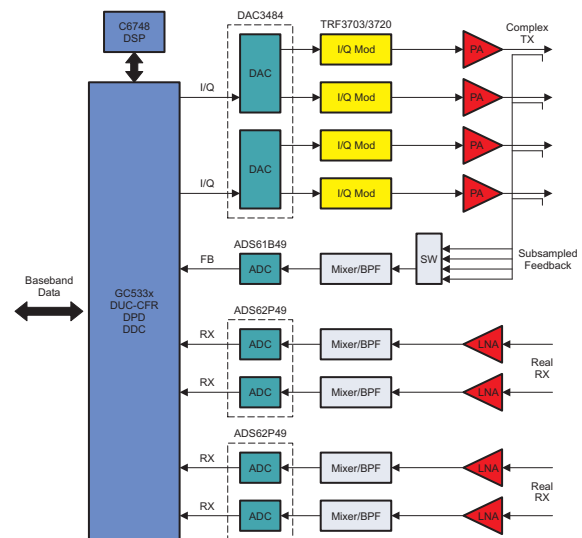

B0441-01



Please be aware that an important notice concerning availability, standard warranty, and use in critical applications of Texas Instruments semiconductor products and disclaimers thereto appears at the end of this data sheet.



These devices have limited built-in ESD protection. The leads should be shorted together or the device placed in conductive foam during storage or handling to prevent electrostatic damage to the MOS gates.

DESCRIPTION (Continued)

The CFR block reduces the peak-to-average ratio (PAR) of the digital transmit signals, such as those used in third-generation (3G) code division multiple access (CDMA) and orthogonal frequency-division multiple-access (OFDMA) applications.

The DPD path with a 310-MHz DPD clock can be configured to support one antenna at 62 MHz, two antennas at 62 MHz each, or four antennas at 31 MHz each, all with an associated 5× DPD expansion bandwidth. The GC533x DPD processor reduces power amplifier (PA) nonlinearity, e.g., as measured by adjacent-channel leakage ratio (ACLR), by over 20 dB. By reducing the PAR of the digital signal and the PA nonlinearity, the operational efficiency of follow-on power amplifiers can be substantially improved.

A higher DPD bandwidth is possible with reduced DPD performance. Several architectures that provide performance and cost optimization are listed in [Table 1](#)

Table 1. Sample Configurations for GC5330 {GC5337}

Figure	TX Antenna	DPD Bandwidth	ET Support	Feedback	RX Antenna	Other
Figure 1	2-62 {74} MHz	310 {370} MHz		Subsampled real	2 typical at 250 Msps, up to 4 at 250 Msps	Lower-cost 2-antenna solution
Figure 2	2-62 {74} MHz	310 {370} MHz		Full-rate real up to 1Gsps	2 at 250Msps, 4 with lower-rate RX ADC	2-antenna solution with full-rate real feedback
Figure 3	2-62 {74} MHz	310 {370} MHz		Subsampled complex	2 at 250Msps, 4 with lower-rate RX ADC	2-antenna solution with complex feedback, lower subsampling ratio
Figure 4	2-62 {74} MHz	310 {370} MHz	2-envelope tracking	Full-rate real up to 1Gsps	2 at 250Msps, 4 with lower-rate RX ADC	2-antenna solution, with envelope tracking with full-rate real feedback
Figure 5	4-31 {37} MHz	155 {185} MHz		Subsampled real	4 at 250Msps, 8 with lower-rate RX ADC	Lower-cost 4 antenna solution

ANTENNA MODE EXAMPLE DIAGRAMS

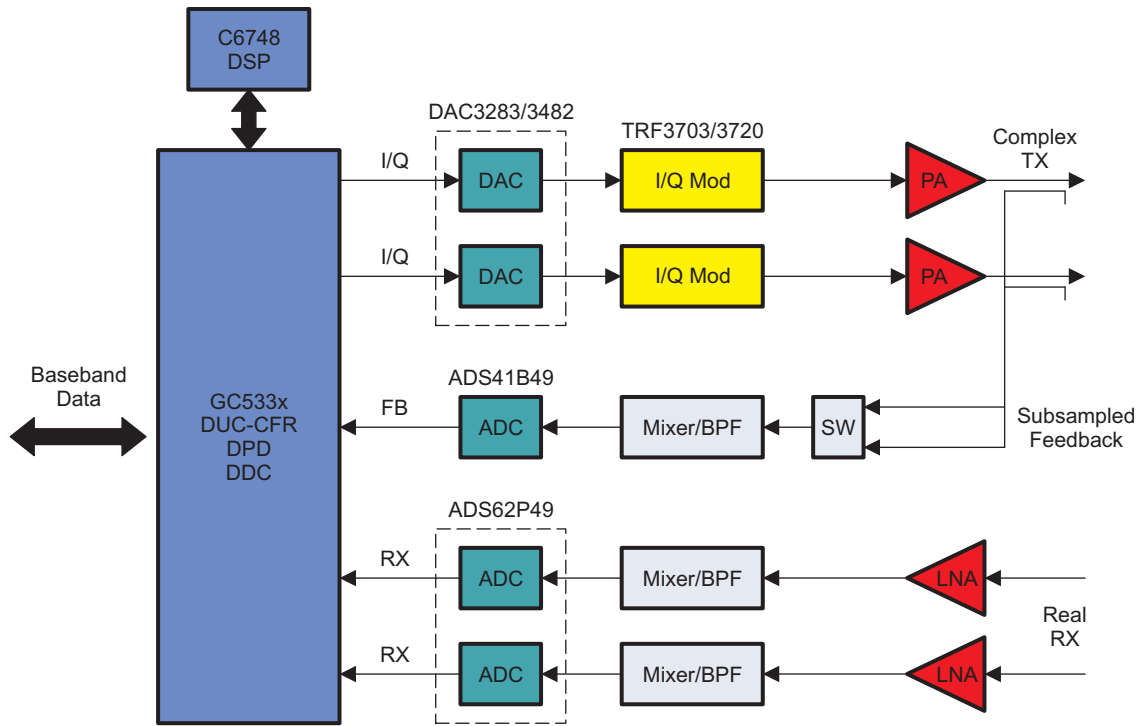

B0442-01

Figure 1. Two-Antenna-Mode Subsampled-Feedback Diagram

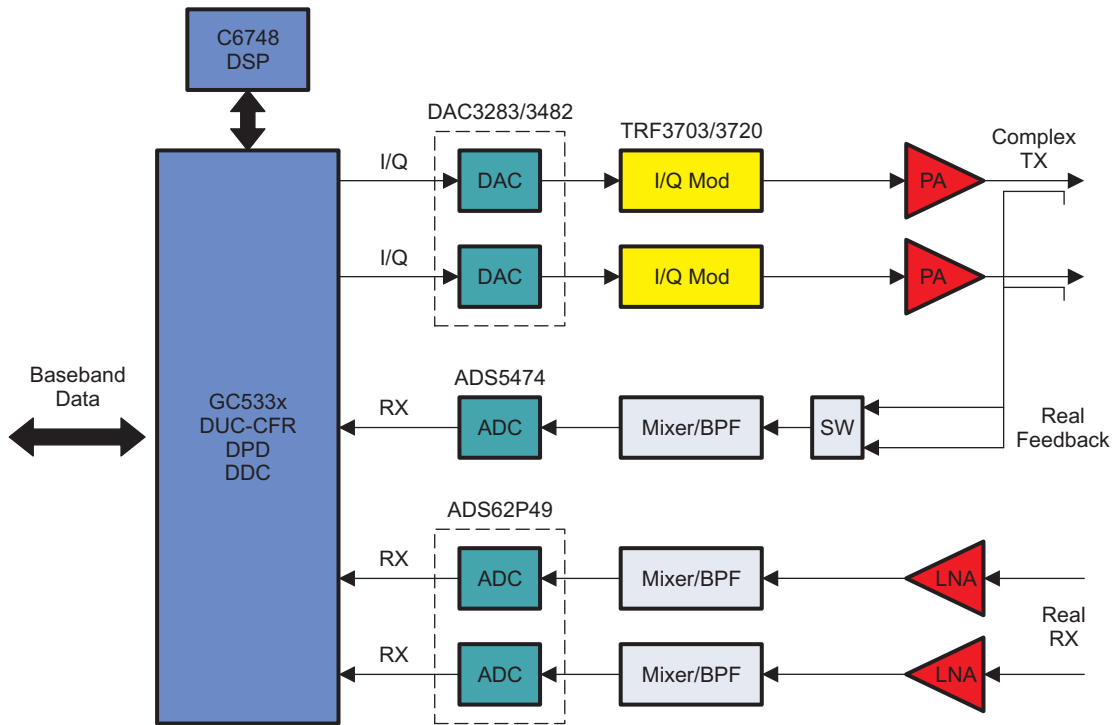

B0443-01

Figure 2. Two-Antenna-Mode Full-Rate Real-Feedback Diagram

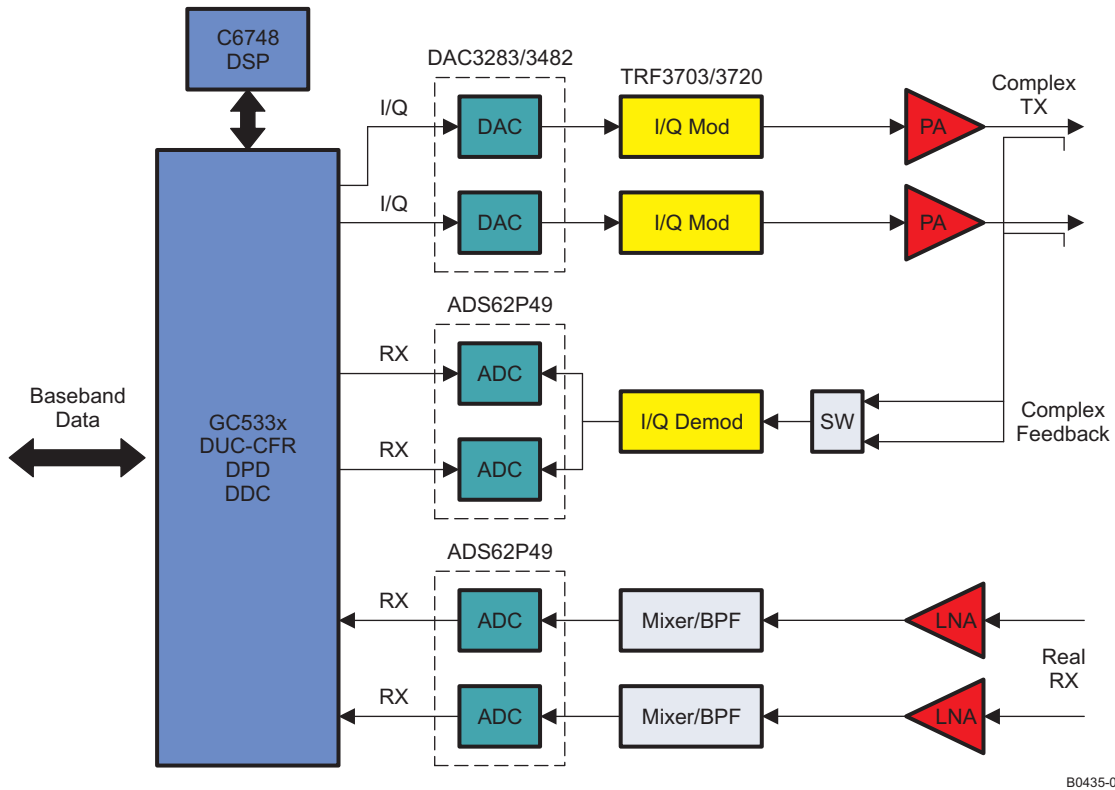

Figure 3. Two-Antenna-Mode Complex-Feedback Diagram

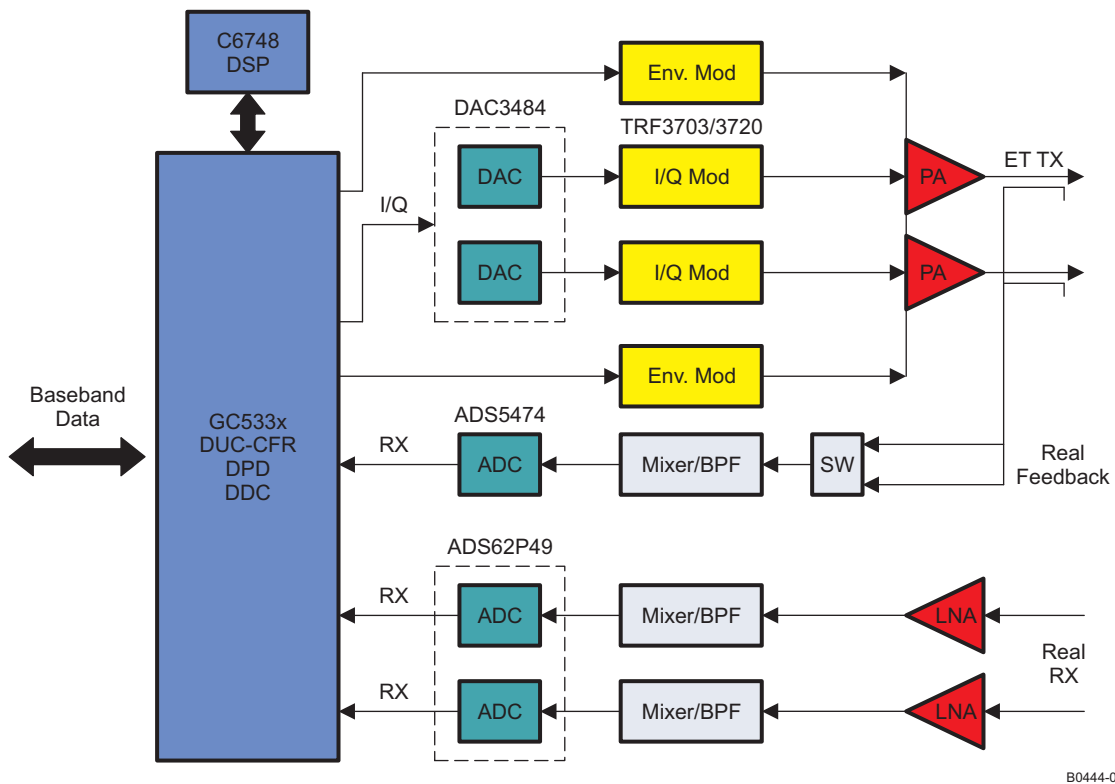
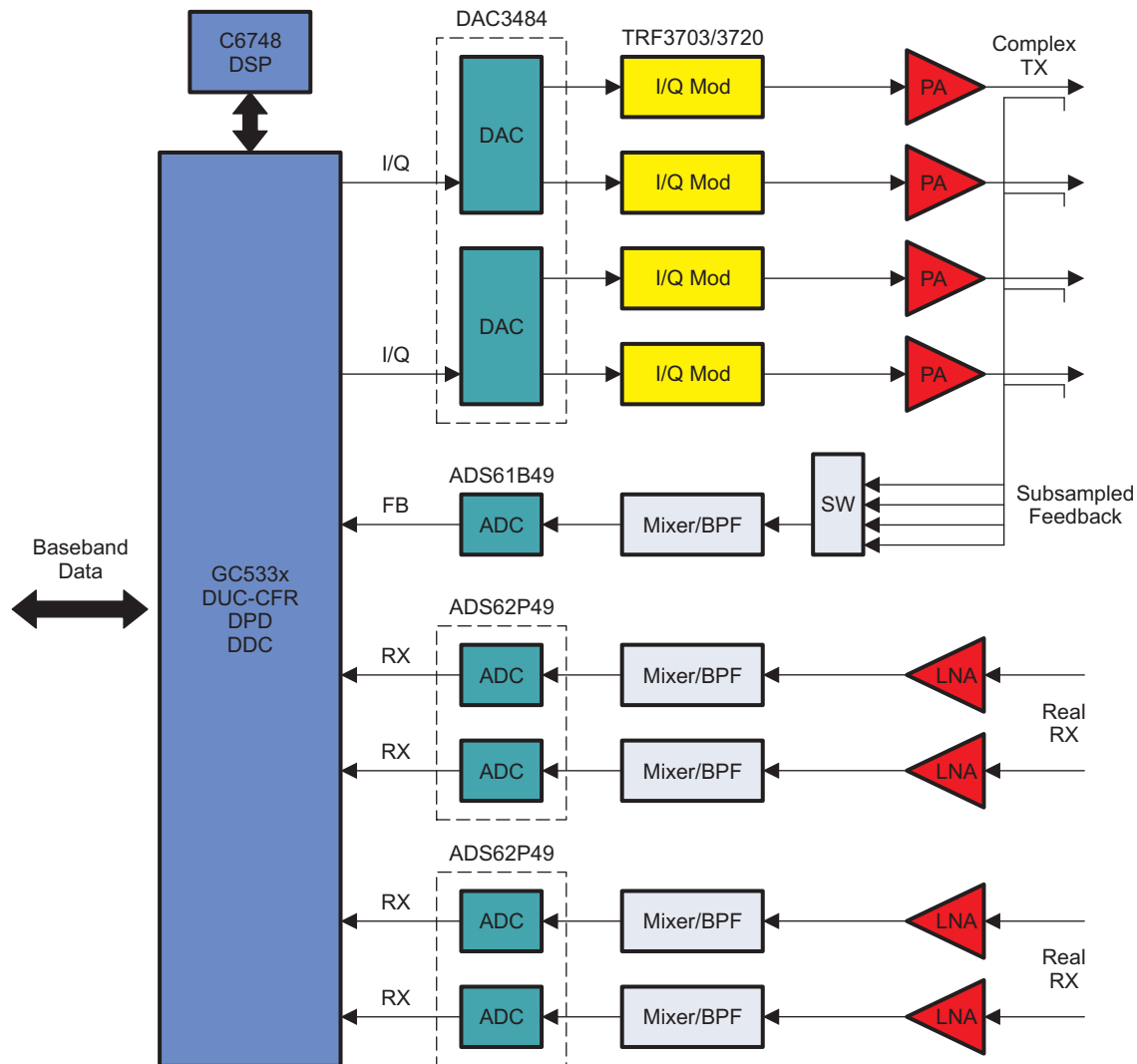

Figure 4. Two-Antenna-Mode, Envelope-Tracking, Full-Rate Real-Feedback Diagram



B0441-01

Figure 5. Four-Antenna-Mode Subsampled Real-Feedback Example Diagram

GENERAL DESCRIPTION

The GC533x is a wideband transmit and receive signal processor that includes digital downconverter/upconverter (DDUC), transmit, receive, and capture buffer blocks. The transmit path includes crest factor reduction (CFR), digital predistortion (DPD) and associated feedback path, complex equalization, and bulk upconversion. The receive path includes wideband and narrowband automatic gain control (AGC), bulk downconversion, complex equalization, and I/Q imbalance correction. The GC5337 is a higher-speed version of the GC5330 that has the same package, but with interfaces that can provide more processing performance for higher-bandwidth applications. In the descriptions, the GC5337 differences are shown with { } values.

The architecture supports different RX, TX, and feedback modes of operation. This provides for many configurations to optimize performance and cost.

- RX – real or complex input
- TX – real, complex, complex with envelope tracking
- Feedback – subsampled real, full-rate real, full-rate complex

The RX path can be configured for one or two multichannel ADC input ports. The RX block provides each ADC channel with a front-end AGC, IQ demodulation correction, real-to-complex conversion, complex mixing, decimation, and complex equalization. The RX block output is input to the DDUC block. The output of the DDUC block goes through gain and back-end AGC and is formatted for the baseband output.

There are four DDUC blocks. Each can be used for the RX DDC downconversion or TX DUC upconversion, one at a time. The DDUC has a complex mixer, cascade integrator comb filter, resampler, and a programmable FIR filter. Each DDUC can support 1 to 12 channels.

The TX path can be configured for one, two, or four antenna streams. In addition, with one or two antenna streams, an envelope modulator output is available. The DAC and envelope modulator share the same output ports. The TX input is from the baseband input, through the DDUC to create complex antenna streams. The CFR block provides for gain adjustment, peak reduction, and peak limiting. The CFR block peak power reduction and follow-on circular limiter provide the headroom to apply the DPD correction, and to lower the peak power results for more power amplifier efficiency. Additional interpolation stages after CFR expand the antenna stream bandwidth to the DPD bandwidth.

The DPD has both high-performance (more correction) and high-bandwidth (more bandwidth) modes. The high-bandwidth mode supports 62 MHz {74 MHz} for one or two antenna streams, and 31 MHz {37 MHz} for four antenna streams with fifth-order expansion bandwidth. The high-performance mode supports one antenna at 62 MHz {74 MHz}, two antennae at 31 MHz {37 MHz}, or four antennae at 15.5 MHz {18.5 MHz}. The GC533x DPD processor provides phase correction, gain correction, and nonlinear feedforward correction for each TX stream. The spectral emission or ACP performance is improved by 20 dB or more.

Specialized capture logic collects the RX input, feedback input, RX output, DPD input, and DPD output for the DSP processor to perform the adaption algorithm. The capture logic can also be used for performance monitoring and power measurement.

AVAILABLE OPTIONS

PART NUMBER	T _c	PACKAGE	THERMAL PROPERTIES
GC5330IZEV	–40°C to 85°C	484 ball 23-mm × 23-mm PBGA	Heat transfer through package top
GC5337IZEV	–40°C to 85°C	484 ball 23-mm × 23-mm PBGA	Heat transfer through package top

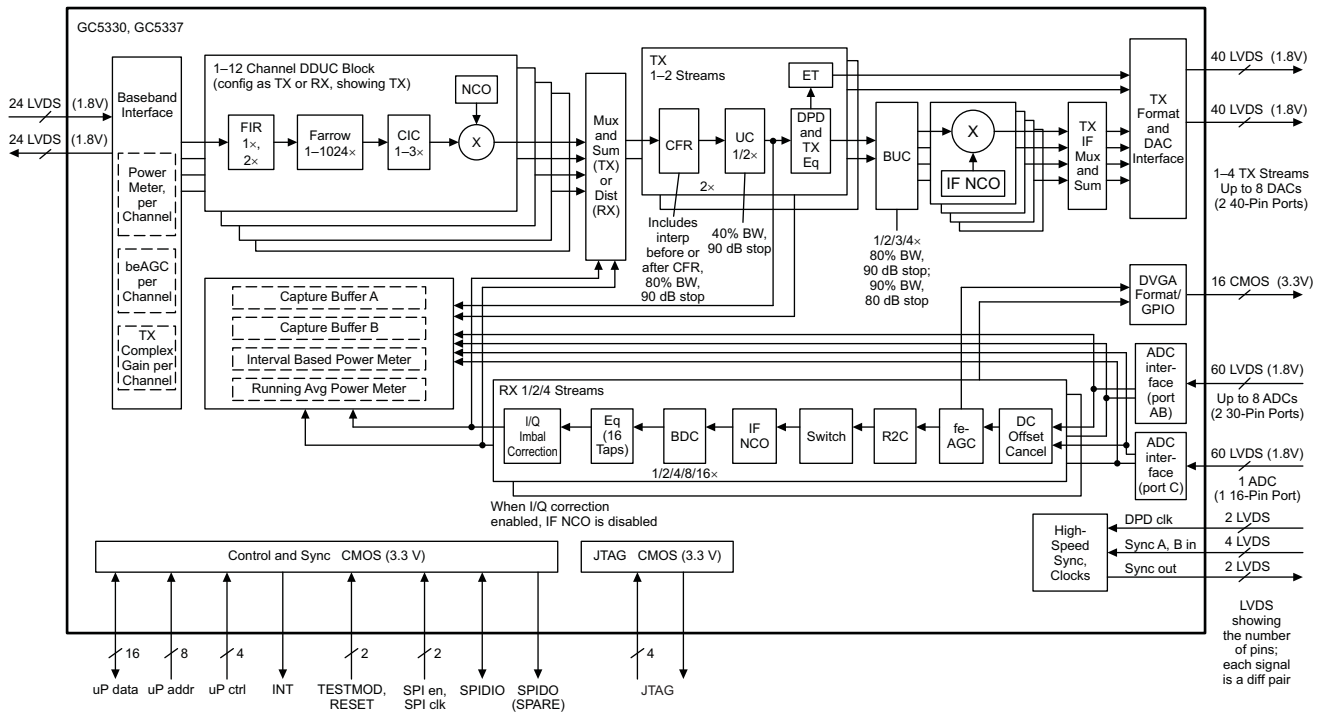

B0445-01

NOTE: UC1 and UC2 are for CFR interpolation; UC2 can only be used if UC1 is also used.

Figure 6. GC533x Block Diagram

GC533x Introduction

The GC533x is a flexible transmit and receive digital signal processor that includes receiver and transmitter blocks, digital downconverter / upconverter (DDUC) blocks, crest factor reduction (CFR) and digital predistortion (DPD) engines, flexible LVDS data converter and baseband interfaces, and capture buffers for DPD and adaptive filtering algorithms.

Each of the four DDUC blocks can be configured as either a digital downconverter (DDC) or a digital upconverter (DUC). Typically, a system can be implemented as both TX and RX, with both DDC and DUC functions. The DDUC blocks provide programmable FIR filters with flexible numbers of taps, depending on signal bandwidth and number of channels, as well as fractional resamplers, CIC filters, and complex mixers. The DDUC complex mixers support static or hopping tuning functions.

beAGC after the DDC is part of the baseband interface. Static gain is applied in the BB block for both the DDC output and DUC input.

The receiver block provides dc offset correction, front-end AGC, real-to-complex conversion, complex mixing, decimating filters, a complex equalizer, and a blind RX IQ imbalance correction function.

The CFR block reduces the peak-to-average ratio (PAR) of complex, arbitrary TX signals. Reducing the PAR of the TX signal allows wireless-infrastructure (WI) base stations and repeaters to use smaller and lower-cost multi-carrier power amplifiers (MCPAs).

The DPD block can process one or two TX streams at 62 MHz {74 MHz} or four TX streams at 31 MHz {37 MHz} each, with fifth-order nonlinear correction. The DPD engine uses a companion TI DSP TMS320C6748 to collect the reference and feedback data, calculate the feedforward correction, and update the GC533x registers.

In WI applications, the GC533x meets multi-carrier 3G and 4G performance standards (PCDE, composite EVM, and ACLR) at PAR levels down to 6 dB for WCDMA and 7 dB for LTE, and improves the ACLR by over 20 dB at the PA output. The GC533x integrates easily into the transmit/receive signal chain between Texas Instruments' high-performance data converters and baseband processors such as the TI TMS320C64xx family. In wireless repeater applications, the GC533x can provide seamless interfaces to TI data converters, along with receive and transmit filtering, DDC, and DUC functions.

The GC533x is extremely flexible and can be used in system architectures with different signal types and TX-by-RX antenna configurations such as 2×2, 2×4, 4×4, and 4×8.

The GC533x EVM system provides an example sector transmit-receive signal chain solution, from the multi-carrier baseband to the RF antenna.

ABSOLUTE MAXIMUM RATINGS

over recommended operating free-air temperature range (unless otherwise noted)⁽¹⁾

		MIN	MAX	UNIT
V _{DD}	Core supply voltage	-0.3	1.32	V
V _{DDA}	PLL analog voltage	-0.3	2	V
V _{DDS}	Digital supply voltage for TX	-0.3	2	V
V _{DDSHV}	Digital supply voltage	-0.3	3.6	V
V _{IN}	Input voltage (under/overshoot)	-0.5	V _{DDSHV} + 0.5	V
	Clamp current for an input/output	-20	20	mA
T _{stg}	Storage temperature	-65	140	°C
	ESD classification	Class 2 (2.5 kV HBM, 500 V CDM, 150 V MM)		
	Moisture sensitivity	Moisture sensitivity Class 3 (1 week floor life at 30°C / 60% H)		

- (1) Stresses beyond those listed under *Absolute Maximum Ratings* may cause permanent damage to the device. These are stress ratings only, and functional operation of the device at these or any other conditions beyond those indicated under *Recommended Operating Conditions* is not implied. Exposure to absolute-maximum-rated conditions for extended periods may affect device reliability.

RECOMMENDED OPERATING CONDITIONS

		MIN	TYP	MAX	UNIT
V _{DD}	Core supply voltage ⁽¹⁾	310 MHz, 5.7 A max. ⁽²⁾⁽¹⁾			V
		{370 MHz} ⁽³⁾			
V _{DDA}	Analog supply for PLLs	60 mA max. (each) ⁽²⁾			
V _{DDS}	Digital supply voltage for LVDS I/O	700 mA max. ⁽²⁾			V
V _{DDSHV}	Digital supply voltage CMOS I/O	PC board design dependent			V
T _C	Case temperature	-40	30	90	°C
T _J	Junction temperature	⁽⁴⁾			105 °C

- (1) Production tested hot using checksum at 310 MHz and maximum supplies. Power scales linearly with frequency with a dc consumption around 350 mA typical, 700 mA worst case.
- (2) Chip specifications are production tested to 90°C case temperature. QA tests are performed at 85°C.
- (3) Power consumption is a strong function of the configuration. A calculator is available to estimate power for a specific configuration.
- (4) Reliability calculations presume junction temperature 105°C or below. Operation above 105°C junction temperature reduces product lifetime.

THERMAL INFORMATION

THERMAL METRIC		GC5330	UNIT
		ZEV	
		484 PINS	
θ_{JA}	Junction-to-ambient thermal resistance ⁽¹⁾	15.4	°C/W
θ_{JcTop}	Junction-to-case (top) thermal resistance ⁽²⁾	2.1	°C/W
θ_{JB}	Junction-to-board thermal resistance ⁽³⁾	7.6	°C/W
ψ_{JT}	Junction-to-top characterization parameter ⁽⁴⁾	0.5	°C/W
ψ_{JB}	Junction-to-board characterization parameter ⁽⁵⁾	7.5	°C/W
θ_{JcBot}	Junction-to-case (bottom) thermal resistance ⁽⁶⁾	N/A	°C/W

- (1) The junction-to-ambient thermal resistance under natural convection is obtained in a simulation on a JEDEC-standard, high-K board, as specified in JESD51-7, in an environment described in JESD51-2a.
- (2) The junction-to-case (top) thermal resistance is obtained by simulating a cold plate test on the package top. No specific JEDEC-standard test exists, but a close description can be found in the ANSI SEMI standard G30-88.
- (3) The junction-to-board thermal resistance is obtained by simulating in an environment with a ring cold plate fixture to control the PCB temperature, as described in JESD51-8.
- (4) The junction-to-top characterization parameter, ψ_{JT} , estimates the junction temperature of a device in a real system and is extracted from the simulation data for obtaining θ_{JA} , using a procedure described in JESD51-2a (sections 6 and 7).
- (5) The junction-to-board characterization parameter, ψ_{JB} , estimates the junction temperature of a device in a real system and is extracted from the simulation data for obtaining θ_{JA} , using a procedure described in JESD51-2a (sections 6 and 7).
- (6) The junction-to-case (bottom) thermal resistance is obtained by simulating a cold plate test on the exposed (power) pad. No specific JEDEC standard test exists, but a close description can be found in the ANSI SEMI standard G30-88.

Pin Assignment and Descriptions (Top View)

	1	2	3	4	5	6	7	8	9	10	11	12	13	14	15	16	17	18	19	20	21	22		
A	NC	BBIN5P	BBIN4P	BBIN3P	BBIN1P	SPIDENB	SPICLK	CEB	UPA5	UPA2	UPD15	UPD12	UPD8	UPD5	UPD1	VSSA2	SYNCBN	SYNC OUTN	SYNC OUTP	TXA1N	TXA2P	NC	A	
B	BBIN7N	BBIN7P	BBIN5N	BBIN4N	BBIN3N	BBIN1N	SPIDIO	INTERRPT	UPA6	UPA3	WEB	UPD13	UPD9	UPD6	UPD2	UPD0	VDDA2	SYNCBP	TXA0N	TXA1P	TXA2N	TXA5N	B	
C	BBIN8N	BBIN8P	BBIN6P	BBIN6N	VSSA1	BBIN2P	BBIN0P	EMIFENA	UPA7	UPA4	UPA0	UPD14	UPD10	UPD7	UPD3	SYNCAP	DPDCLKP	TXA0P	TXA3P	TXA4P	TXA4N	TXA5P	C	
D	NC	BBIN9N	BBIN9P	NC	VDDA1	BBIN2N	BBIN0N	VSS	OEB	VSS	UPA1	VSS	UPD11	VSS	UPD4	SYNCAN	DPDCLKN	TXA3N	TXA6N	TXA7N	TXA8N	TXA9P	D	
E	BBOUT0P	BBIN10P	BBIN10N	BBIN11P	BBIN11N	VDD	VDD	VDD	VDD	VDD	VDD	VDD	VDD	VDD	VDD	VDD	NC	NC	TXA6P	TXA7P	TXA8P	TXA9N	E	
F	BBOUT0N	BBOUT2N	BBOUT2P	BBOUT1N	BBOUT1P	NC	VDDS2	VDDSHV1	VDD	VDDSHV1	VDD	VDDSHV1	VDD	VDDSHV1	VDD	VDD	VDDS1	NC	VDD	TXA11N	TXA11P	TXA10N	TXA10P	F
G	BBOUT4N	BBOUT4P	BBOUT3N	BBOUT3P	VDDS2	VSS	VSS	VSS	VSS	VSS	VSS	VSS	VSS	VSS	VSS	VSS	VSS	VSS	VDD	TXA13P	TXA13N	TXA12P	TXA12N	G
H	BBOUT6N	BBOUT6P	BBOUT5N	BBOUT5P	VDD	VSS	VSS	VSS	VSS	VSS	VSS	VSS	VSS	VSS	VSS	VSS	VSS	VSS	VDD	TXA15P	TXA15N	TXA14N	TXA14P	H
J	BBOUT8N	BBOUT8P	BBOUT7N	BBOUT7P	VDD	VSS	VSS	VSS	VSS	VSS	VSS	VSS	VSS	VSS	VSS	VSS	VSS	VSS	VDD	TXA17P	TXA17N	TXA16N	TXA16P	J
K	BBOUT10N	BBOUT10P	BBOUT9N	BBOUT9P	VDDS2	VSS	VSS	VSS	VSS	VSS	VSS	VSS	VSS	VSS	VSS	VSS	VSS	VSS	VDD	TXA19N	TXA19P	TXA18N	TXA18P	K
L	RXA13P	RXA14N	RXA14P	BBOUT11P	BBOUT11N	VSS	VSS	VSS	VSS	VSS	VSS	VSS	VSS	VSS	VSS	VSS	VSS	VSS	VDD	TXB1P	TXB1N	TXB0P	TXB0N	L
M	RXA13N	RXA12P	RXA11N	RXA11P	VDDS2	VSS	VSS	VSS	VSS	VSS	VSS	VSS	VSS	VSS	VSS	VSS	VSS	VSS	VDD	TXB3P	TXB3N	TXB2P	TXB2N	M
N	RXA12N	RXA10P	RXA9N	RXA9P	VDD	VSS	VSS	VSS	VSS	VSS	VSS	VSS	VSS	VSS	VSS	VSS	VSS	VSS	VDD	TXB5P	TXB5N	TXB4P	TXB4N	N
P	RXA10N	RXA8N	RXA8P	RXA7N	RXA7P	VSS	VSS	VSS	VSS	VSS	VSS	VSS	VSS	VSS	VSS	VSS	VSS	VSS	VDD	TXB7P	TXB7N	TXB6P	TXB6N	P
R	RXA6N	RXA6P	RXA5N	RXA5P	VDD	VSS	VSS	VSS	VSS	VSS	VSS	VSS	VSS	VSS	VSS	VSS	VSS	VSS	VDD	TXB9P	TXB9N	TXB8P	TXB8N	R
T	RXA4N	RXA3N	RXA3P	RXA2N	RXA2P	VSS	VSS	VSS	VSS	VSS	VSS	VSS	VSS	VSS	VSS	VSS	VSS	VSS	VDD	TXB11P	TXB11N	TXB10P	TXB10N	T
U	RXA4P	RXA1P	RXA0N	RXA0P	VDD	NC	VDDS2	VDD	VDDSHV2	VDD	VDDSHV2	VDD	VDDSHV2	VDD	VDD	VDD	VDD	VDD	VDD	TXB13P	TXB13N	TXB12P	TXB12N	U
V	RXA1N	RXB14N	RXB10N	RXB10P	NC	NC	VDD	VDD	VDD	VDD	VDD	VDD	VDD	VDD	VDD	VDD	NC	NC	TXB15P	TXB15N	TXB14N	TXB14P	V	
W	RXB14P	RXB13P	NC	RXB6P	RXB6N	RXB4P	RXB2P	VPP	VSS	VPP	VSS	DVGA6	VSS	TDO	TMS	RXC6N	RXC4N	NC	TXB17P	TXB17N	TXB16P	TXB16N	W	
Y	RXB13N	RXB12N	RXB8N	RXB8P	RXB5P	RXB4N	RXB2N	VDDMON	RESETB	DVGA13	DVGA10	DVGA7	DVGA3	DVGA0	TDI	RXC6P	RXC5N	RXC4P	TXB19N	TXB19P	TXB18N	TXB18P	Y	
AA	RXB12P	RXB11P	RXB9P	RXB7N	RXB5N	RXB3P	RXB1N	VSSMON	SPIDIO (SPARE)	DVGA14	DVGA11	DVGA8	DVGA4	DVGA1	TRSTB	RXC7N	RXC5P	RXC3P	RXC2N	RXC2P	RXC0N	NC	AA	
AB	NC	RXB11N	RXB9N	RXB7P	NC	RXB3N	RXB1P	RXB0P	RXB0N	TESTMOD	DVGA15	DVGA12	DVGA9	DVGA5	DVGA2	TCK	RXC7P	RXC3N	RXC1N	RXC1P	RXC0P	NC	AB	

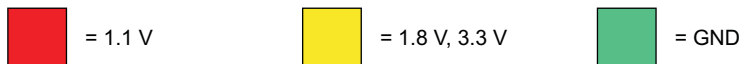

P0131-01

Figure 7. GC533x Pinout (Top View)

Pin Functions

NAME	NUMBER	TYPE	DESCRIPTION
POWER AND BIASING			
VDD	E6, E7, E8, E9, E10, E11, E12, E13, E14, E15, E16, F9, F11, F13, F15, F18, G18, H5, J5, J18, L18, N5, N18, P18, R5, T18, U5, U8, U10, U12, U14, U15, U18, V7, V8, V9, V10, V11, V12, V13, V14, V15, V16	PWR	1.1-V power supply
VDDSHV2	U9, U11, U13	PWR	3.3-V power supply for CMOS I/O
VDDSHV1	F8, F10, F12, F14	PWR	3.3-V power supply for CMOS I/O
VDDS1	F16, H18, K18, M18, R18, U16,	PWR	1.8-V power supply for LVDS I/O
VDDS2	F7, G5, K5, M5, U7	PWR	1.8-V power supply for LVDS I/O
VPP	W8, W10	PWR	1.1-V E-fuse supply, connect to VDD
VDDMON	Y8	NC	Do not connect, internal monitor point
VSSMON	AA8	NC	Do not connect, internal monitor point
VDDA2	B17	PWR	1.8-V power for PLL (requires filtering)
VDDA1	D5	PWR	1.8-V power for PLL (requires filtering)
VSSA2	A16	PWR	Ground for PLL (requires filtering)
VSSA1	C5	PWR	Ground for PLL (requires filtering)
VSS	D8, D10, D12, D14, G6, G7, G8, G9, G10, G11, G12, G13, G14, G15, G16, G17, H6, H7, H8, H9, H10, H11, H12, H13, H14, H15, H16, H17, J6, J7, J8, J9, J10, J11, J12, J13, J14, J15, J16, J17, K6, K7, K8, K9, K10, K11, K12, K13, K14, K15, K16, K17, L6, L7, L8, L9, L10, L11, L12, L13, L14, L15, L16, L17, M6, M7, M8, M9, M10, M11, M12, M13, M14, M15, M16, M17, N6, N7, N8, N9, N10, N11, N12, N13, N14, N15, N16, N17, P6, P7, P8, P9, P10, P11, P12, P13, P14, P15, P16, P17, R6, R7, R8, R9, R10, R11, R12, R13, R14, R15, R16, R17, T6, T7, T8, T9, T10, T11, T12, T13, T14, T15, T16, T17, W9, W11, W13	PWR	Ground
NC	E17, E18, F6, F17, U6, U17, V5, V6, V17, V18	NC	No connection. Recommend connecting to ground
NC	A1, A22, D1, D4, W3, W18, AA22, AB1, AB5, AB22,	NC	No connection
BASEBAND INPUT/OUTPUT			
BBIN[11:0]P	E4, E2, D3, C2, B2, C3, A2, A3, A4, C6, A5, C7	I	Baseband input – LVDS positive
BBIN[11:0]N	E5, E3, D2, C1, B1, C4, B3, B4, B5, D6, B6, D7	I	Baseband input – LVDS negative
BBOUT[11:0]P	L4, K2, K4, J2, J4, H2, H4, G2, G4, F3, F5, E1	O	Baseband output – LVDS positive
BBOUT[11:0]N	L5, K1, K3, J1, J3, H1, H3, G1, G3, F2, F4, F1	O	Baseband output – LVDS negative
TX DAC INTERFACE			
TXA[19:0]P	K20, K22, J19, J22, H19, H22, G19, G21, F20, F22, D22, E21, E20, E19, C22, C20, C19, A21, B20, C18	O	DAC TX port A – LVDS positive
TXA[19:0]N	K19, K21, J20, J21, H20, H21, G20, G22, F19, F21, E22, D21, D20, D19, B22, C21, D18, B21, A20, B19	O	DAC TX port A – LVDS negative
TXB[19:0]P	Y20, Y22, W19, W21, V19, V22, U19, U21, T19, T21, R19, R21, P19, P21, N19, N21, M19, M21, L19, L21	O	DAC TX port B – LVDS positive
TXB[19:0]N	Y19, Y21, W20, W22, V20, V21, U20, U22, T20, T22, R20, R22, P20, P22, N20, N22, M20, M22, L20, L22	O	DAC TX port B – LVDS negative
RX and FB ADC INTERFACE			
RXA[14:0]P	L3, L1, M2, M4, N2, N4, P3, P5, R2, R4, U1, T3, T5, U2, U4	I	ADC receive port A – LVDS positive
RXA[14:0]N	L2, M1, N1, M3, P1, N3, P2, P4, R1, R3, T1, T2, T4, V1, U3	I	ADC receive port A – LVDS negative
RXB[14:0]P	W1, W2, AA1, AA2, V4, AA3, Y4, AB4, W4, Y5, W6, AA6, W7, AB7, AB8	I	ADC receive port B – LVDS positive
RXB[14:0]N	V2, Y1, Y2, AB2, V3, AB3, Y3, AA4, W5, AA5, Y6, AB6, Y7, AA7, AB9	I	ADC receive port B – LVDS negative
RXC[7:0]P	AB17, Y16, AA17, Y18, AA18, AA20, AB20, AB21	I	ADC receive port C – LVDS positive
RXC[7:0]N	AA16, W16, Y17, W17, AB18, AA19, AB19, AA21	I	ADC receive port C – LVDS negative

Pin Functions (continued)

NAME	NUMBER	TYPE	DESCRIPTION
DVGA INTERFACE			
DVGA[15:0]	AB11, AA10, Y10, AB12, AA11, Y11, AB13, AA12, Y12, W12, AB14, AA13, Y13, AB15, AA14, Y14	O	
MPU INTERFACE			
UPD[15:0]	A11, C12, B12, A12, D13, C13, B13, A13, C14, B14, A14, D15, C15, B15, A15, B16	I/O	
UPA[7:0]	C9, B9, A9, C10, B10, A10, D11, C11	I	
WEB	B11	I	Write enable, active-low
EMIFENA	C8	I	EMIFENA switches between address/data μ P access and SPI access. Its value may be changed at any time, but both address/data access and SPI access must be idle during the change. Logic 1 = EMIF, logic 0 = SPI pin has internal pullup.
OEB	D9	I	Read and output enable, active-low
CEB	A8	I	Chip enable, active-low
JTAG INTERFACE			
TRSTB	AA15	I	JTAG reset (active-low); pull down if JTAG is not used.
TMS	W15	I	JTAG mode select
TDO	W14	O	JTAG data out
TDI	Y15	I	JTAG data in
TCK	AB16	I	JTAG clock
SPI INTERFACE			
SPIDENB	A6	I	Serial interface enable
SPICLK	A7	I	Serial interface clock
SPIDIO	B7	I/O	Serial interface data
SPIDO(SPARE)	AA9	O	Serial interface data out in four-wire SPI mode
MISCELLANEOUS			
TESTMOD	AB10	I	Test mode for GC533x, typically grounded
RESETB	Y9	I	Chip reset – required – active-low
INTERRPT	B8	O	Output interrupt
DPDCLKP	C17	I	DPD CLK input – LVDS positive
DPDCLKN	D17	I	DPD CLK input – LVDS negative
SYNCOUTP	A19	O	Sync output – LVDS positive
SYNCOUTN	A18	O	Sync output – LVDS negative
SYNCAP	C16	I	Sync input A – LVDS positive
SYNCAN	D16	I	Sync input A – LVDS negative
SYNCBP	B18	I	Sync input B – LVDS positive
SYNCBN	A17	I	Sync input B – LVDS negative

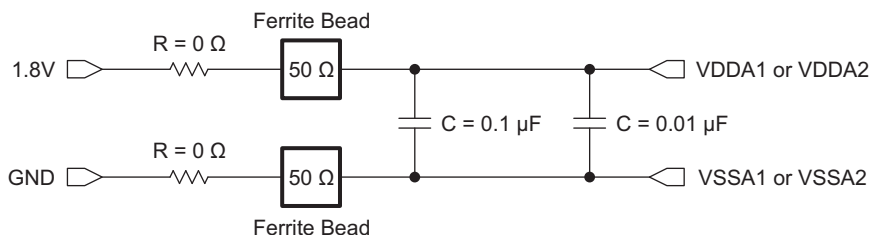

S0510-01

NOTE: 0- Ω R0603 resistor is used to accommodate series resistor if needed.**Figure 8. GC533x PLL Filtering**

The two GC533x PLLs require a filtered power supply. The supply can be generated by filtering the digital supply (VDDS1, VSSA1, VDDS2, and VSSA2). A representative filter is shown in Figure 8. The two PLLs should have separate filters that are located as close as is reasonable to their respective pins (especially the bypass capacitors). The ferrite beads should be series 50R (similar to Murata P/N: BLM31P500SPT, Description: IND FB BLM31P500SPT 50R 1206).

Sub-Chip Descriptions

Figure 9 shows the TX functional block diagram, and Figure 10 shows the RX functional block diagram. Note that each figure shows up to four DUC or DDC blocks in the TX or RX paths, and there are a total of four DDUC blocks that may be configured as either DUC or DDC each.

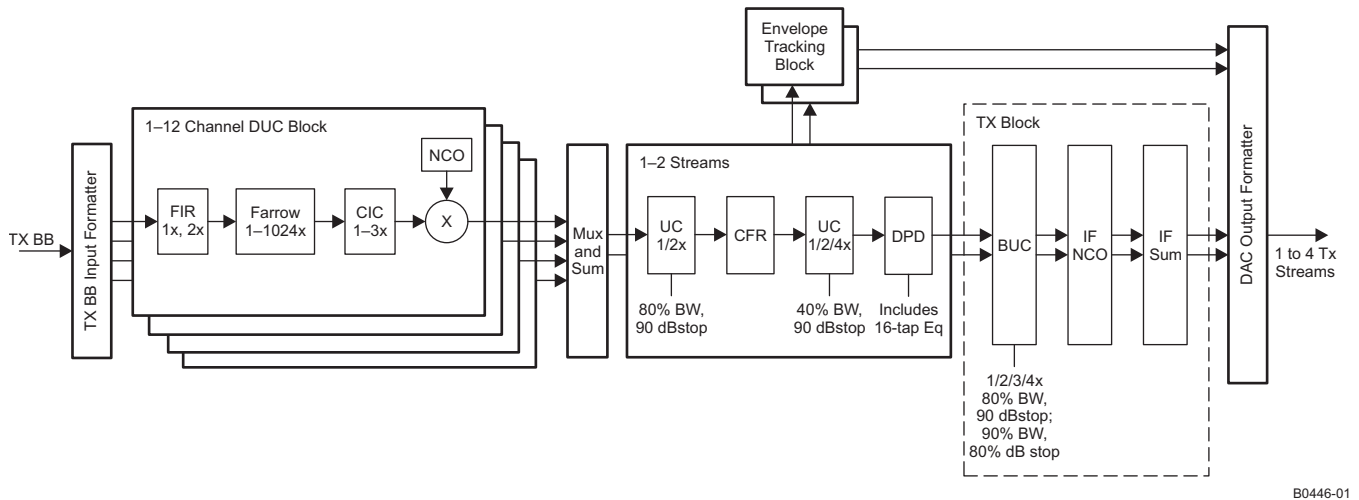

B0446-01

Figure 9. TX Functional Block Diagram

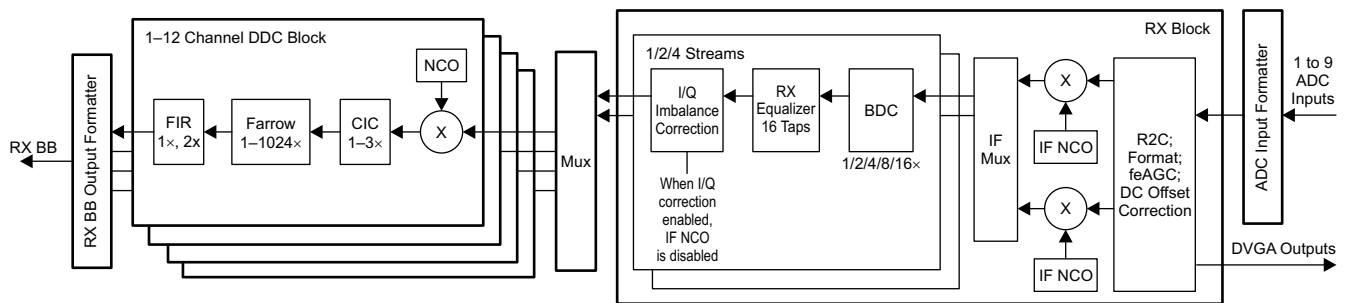

B0447-01

Figure 10. RX Functional Block Diagram

TX Baseband Input Formatter

The TX baseband (BB) input-formatter block accepts TX baseband inputs from the FPGA or baseband processor and formats them for the DUC blocks. There are 12 unidirectional LVDS pairs for the TX input formatter, and their function depends on the operational mode. There are three operational modes for the TX BB input formatter: byte mode (B, 8 or 9 bits), nibble mode (N, 4 bits), and serial mode (S, 2 bits) to allow multiple BB input rates. The GC533x can accept up to three different BB input data rates. Table 2 and Table 3 summarize each mode and the pin assignments. In Table 3, BBIN[X] is the BBIN differential pair (assumed positive and negative connections), and BB0, BB1, and BB2 represent three different TX baseband ports at arbitrary rates.

Table 2. TX BB Formatter Modes

MODE	DESCRIPTION	Total Number of Interface Pins	Maximum Complex Interface Rate per Channel N is the number of channels.
1B	Byte mode, 1 interface rate	10 or 11 = 8 or 9 data + 1 clk + 1 sync	$(\text{Clk} \times 4/4)/N$; maximum 192.31 MSPS total (for all channels)
1N	Nibble mode, 1 interface rate	6 = 4 data + 1 clk + 1 sync	$(\text{Clk} \times 4/8)/N$; maximum 125 (Nibble 0), 96.15 (Nibble 1) MSPS total
1S	Serial mode, 1 interface rate	4 = 2 data + 1 clk + 1 sync	$(\text{Clk} \times 4/16)/N$; maximum 48.07 MSPS total
2N	Nibble mode, 2 interface rates	12 = 4 data + 1 clk + 1 sync + 4 data + 1 clk + 1 sync	$(\text{Clk} \times 4/8)/N \times 2$; maximum 221.15 MSPS total
2N ⁽¹⁾	Nibble + byte mode, 2 interface rates, RX-ADC input pins used for byte-mode port.	16 = 4 data + 1 clk + 1 sync + 8 data + 1 clk + 1 sync	Nibble port: $(\text{Clk} \times 4/8)/N$; maximum 125 MSPS total Byte port: $(\text{Clk} \times 2/4)/N$; maximum 125, 250 MSPS total
2S	Serial mode, 2 interface rates	8 = 2 data + 1 clk + 1 sync + 2 data + 1 clk + 1 sync	$(\text{Clk} \times 4/16)/N$; maximum 96.15 MSPS total
3S	Serial mode, 3 interface rates	12 = 2 data + 1 clk + 1 sync + 2 data + 1 clk + 1 sync + 2 data + 1 clk + 1 sync	$(\text{Clk} \times 4/16)/N$; maximum 144.23 MSPS total

(1) 2N' is the only configuration that allows a special mode to re-use RX input port A as baseband TX inputs

Table 3. TX BB Pin Assignments

LVDS PAIR BBI[11:0]	BYTE MODE	NIBBLE MODE	SERIAL MODE
BBIN[0] pos. and neg.	BB0_DATA_0	BB0_DATA_0	BB0_DATA_0
BBIN[1] pos. and neg.	BB0_DATA_1	BB0_DATA_1	BB0_DATA_1
BBIN[2] pos. and neg.	BB0_DATA_2	BB0_SYNC	BB0_SYNC
BBIN[3] pos. and neg.	Spare	BB0_CLOCK	BB0_CLOCK
BBIN[4] pos. and neg.	BB0_DATA_3	BB0_DATA_2	BB1_DATA_0
BBIN[5] pos. and neg.	BB0_DATA_4	BB0_DATA_3	BB1_DATA_1
BBIN[6] pos. and neg.	BB0_SYNC	BB1_SYNC	BB1_SYNC
BBIN[7] pos. and neg.	BB0_CLOCK	BB1_CLOCK	BB1_CLOCK
BBIN[8] pos. and neg.	BB0_DATA_5	BB1_DATA_0	BB2_DATA_0
BBIN[9] pos. and neg.	BB0_DATA_6	BB1_DATA_1	BB2_DATA_1
BBIN[10] pos. and neg.	BB0_DATA_7	BB1_DATA_2	BB2_SYNC
BBIN[11] pos. and neg.	BB0_DATA_8	BB1_DATA_3	BB2_CLOCK
Number of BBdata streams	1	2	3
Number of DDR clocks to transfer 1 complex sample	2	4	8

The actual data transfer rate in nibble mode is 2 times higher than the byte mode for the same total throughput. If two ports are required (e.g., to support two different sample rates), and a lower speed on the interface is desired, the GC533x can re-use the RX ADC input port A as a baseband TX input bus. RX ADC port A has 15 pairs of LVDS input pins and supports one set of baseband input data in byte mode. When RX port A is used as a baseband TX input, it cannot be also used as an RX input port.

The baseband interface supports a full-clock or gated-clock format. These formats are shown in [Figure 11](#)

The mapping for the RX port A pins when in BB TX input mode is:

- RXA14: clock
- RXA13: sync
- RXA12–5: BB0_DATA7–0

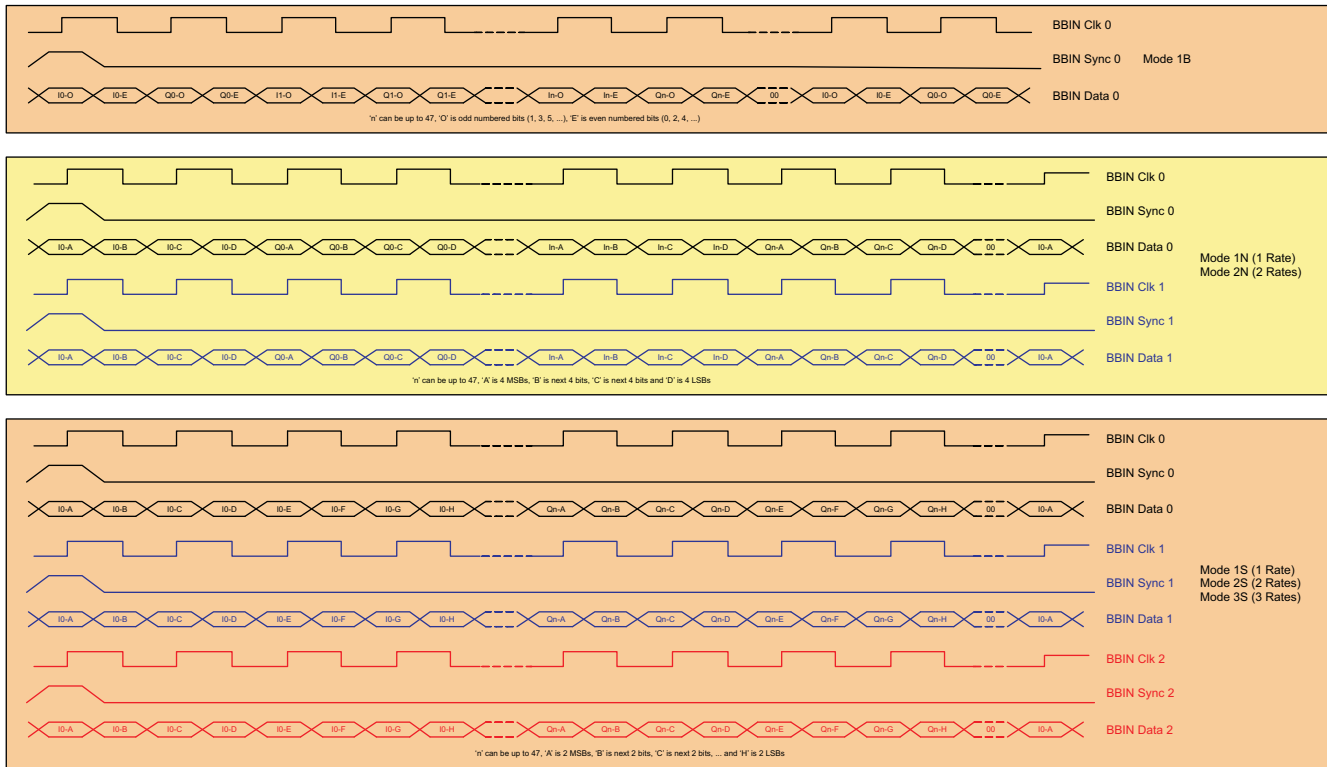

T0504-01

Figure 11. TX BB Formats

The TX formatter block includes a per-channel TX gain adjust via a 16-bit complex digital word which can be set to have gain between $-\infty$ and 9 dB.

Digital Down- and Upconverters (DDUCs)

The GC533x has four identical and independent DDUC blocks that can be configured as either DDC or DUC. Each DDUC can support up to 12 channels with scalable bandwidth.

The only difference between the DUC and DDC configurations is the interpolate (DUC) versus decimate (DDC) functions and the data path direction as shown in Figure 12. Both DDC and DUC are described in this section. Note that each DDUC block must be configured statically as a DUC or DDC and cannot switch modes dynamically in TDD applications.

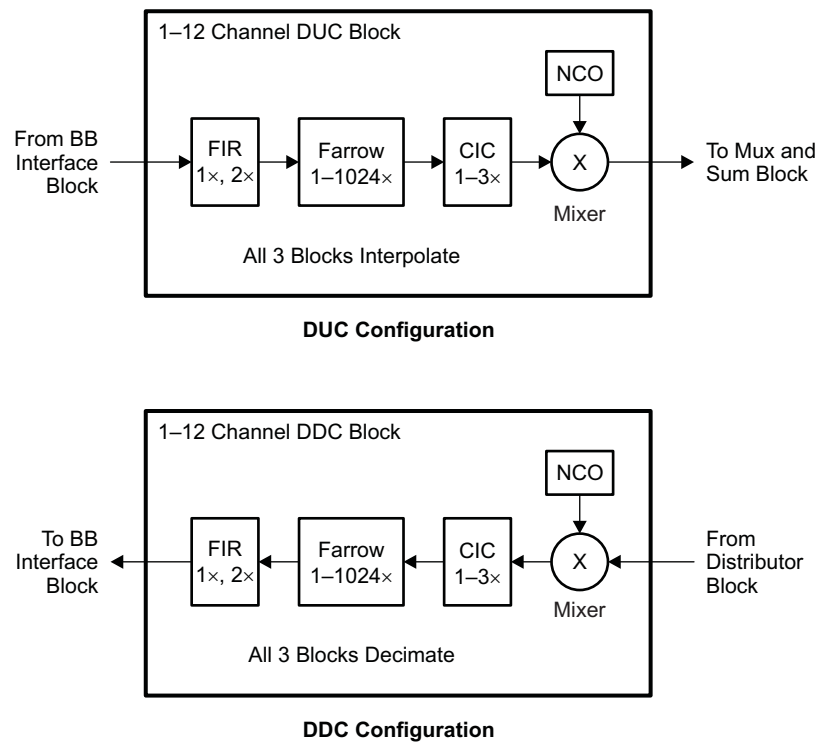

B0448-01

Figure 12. DUC and DDC Functional Block Diagram

In combination with the follow-on mux and sum block, the DUC block interpolates, filters, mixes each carrier, and combines multiple channels into one to four wideband, composite TX signal streams. Any input channel can be mapped to any TX stream in the mux and sum block.

The DDC configuration accepts an RX stream from the distributor block and provides mixing, decimation filtering, fractional resampling, and filtering to RX channels. The RX block outputs are mapped to the mixer CIC stream via the distributor block.

Each DDUC block contains a finite impulse response (FIR) filter, a fractional resampler (Farrow filter), a cascaded integrator-comb (CIC) filter, a complex mixer and NCO for channel placement in the composite stream, and a programmable frequency hopper (see [Figure 12](#)).

The number of taps available in the FIR filter depends on various parameters such as the BBclk rate (derived from DPDCLK), input sample rate, interpolate and decimate settings, and number of channels. Different tap values may be used for each channel (however, that reduces the number of filter taps available).

Note that the input sample rate is the input from the TX BB input formatter for the DUC configuration and the input from the distributor block for DDC configuration. The number of taps for various wireless standards and configurations is shown in [Table 4](#).

The Farrow filter supports one real channel or 1–12 complex channels and can be configured for any resampling ratio from 1 to 1024 with 32-bit resolution. A different delay value for each channel is supported. The Farrow filter is used to resample different TX BB input sample rates to a common CFR and DPD sample rate, and it provides 95-dB rejection at ± 0.25 output f_s (sample rate), 83-dB rejection at ± 0.375 output f_s , and 56-dB rejection at ± 0.4 output f_s .

The CIC interpolates or decimates by a factor of 1, 2, or 3. If each DDUC must support more than eight carriers, the CIC must interpolate/decimate by 3. If each DDUC must support between four and eight carriers, the CIC can interpolate/decimate by 2 or 3. If each DDUC must support fewer than four carriers, the CIC can interpolate by 1, 2, or 3.

The NCO contains a 48-bit frequency word and 48-bit accumulator, and operates at the DUC output sample rate. The minimum resolution is the DUC output sample rate or DDC input sample rate divided by 2^{48} , or about 0.2 μ Hz for a 61.44-MSPS DUC output rate. The mixer and NCO can be used for frequency planning or fine frequency control.

Per-channel phase can be adjusted in the mixer/NCO block with a 16-bit phase word, while per channel fractional delay can be adjusted in the Farrow block.

Table 4. Number of FIR Filter Taps for Example Signal Types

Name	BBclk	Input Sample Rate	Filter Type	DUC Mode Interp.	DDC Mode Decim.	No. of Channels	Max. Taps
	MHz	MSPS	Sym or Un-Sym	1 or 2	1 or 2		
lte20_1	245.76	30.72	S	1	1	1	159
lte20_2	245.76	30.72	S	1	1	2	79
lte10_2	245.76	15.36	S	1	1	2	159
lte10_3	245.76	15.36	S	1	1	3	99
lte10_4	245.76	15.36	S	1	1	4	79
lte5_4	245.76	7.68	S	1	1	4	159
lte5_8	245.76	7.68	S	1	1	8	79
wimax20_r3	246.4	44.8	S	1	2	3	59
wimax20_t3	246.4	22.4	S	2	1	3	39
wimax20_r2	246.4	44.8	S	1	2	2	99
wimax20_t2	246.4	22.4	S	2	1	2	79
wimax20_r1	246.4	44.8	S	1	2	1	219
wimax20_t1	246.4	22.4	S	2	1	1	199
wimax10_r2	246.4	22.4	S	1	2	2	219
wimax10_t2	246.4	11.2	S	2	1	2	199
wimax10_r3	246.4	22.4	S	1	2	3	139
wimax10_t3	246.4	11.2	S	2	1	3	119
wimax10_r4	246.4	22.4	S	1	2	4	99
wimax10_t4	246.4	11.2	S	2	1	4	79
wimax5_r4	246.4	11.2	S	1	2	4	219
wimax5_t4	246.4	5.6	S	2	1	4	199
wimax5_r8	246.4	11.2	S	1	2	8	99
wimax5_t8	246.4	5.6	S	2	1	8	79
wbcdma_r4	245.76	7.68	S	1	1	4	159
wbcdma_t4	245.76	3.84	S	2	1	4	319
wbcdma_r8	245.76	7.68	S	1	1	8	79
wbcdma_t8	245.76	3.84	S	2	1	8	159
cdma_r12	245.76	2.4576	S	1	1	12	99
cdma_t12	245.76	1.2288	U	2	1	12	100
tdscdma_r12	245.76	2.56	S	1	1	12	99
tdscdma_t12	245.76	1.28	S	2	1	12	199
gsm_12	243.8	0.5417	S	1	1	12	99
eedge_12	243.8	1.625	S	1	1	12	99
wideband_60MHz_r	250	75	S	1	1	1	59
wideband_60MHz_t	250	75	S	2	1	1	39

MUX and SUM (TX Direction)

The MUX and SUM block maps any channel from the DUC to any TX stream for subsequent per-stream processing.

Crest Factor Reduction (CFR)

The CFR blocks include the CFR function and two interpolate-by-2 filters (referred to here as UC1 and UC2). The two CFR blocks together can support 1, 2, or 4 TX streams. The CFR function selectively reduces the peak-to-average ratio (PAR) of wideband digital signals provided in quadrature (I and Q) format, such as those used in 3G and 4G wireless applications. For example, the CFR function can reduce the PAR of WCDMA Test Model 1 signals to 5.7 dB, while still meeting all 3GPP requirements for ACLR, composite EVM, and peak code domain error (PCDE).

The CFR blocks can be configured in eleven different modes, depending on the number of TX streams, the DPD mode, and the signal sample rates. Relative to previous TI CFR products, the GC533x CFR has enhanced features such as:

- Constant PAR mode
- Constant input-to-output power mode
- Dynamic PAR target levels for different portions of the time-domain signal
- Up to 25% less latency for certain configurations
- Enhanced CFR performance for narrowband signals
- Automatic (i.e., no host interaction required) CFR coefficient generation for frequency-hopping signals

The UC1 and UC2 blocks can be set to 1× or 2× interpolation and may be used to provide optimum selection of signal oversampling ratio at CFR. UC1 may be positioned before or after the CFR function, while UC2 is always at the output of CFR. Since UC2 has only a 40% bandwidth image rejection (90 dB) filter, it is only used if preceded by UC1, which has an 80% bandwidth image-rejection (90 dB) filter.

Digital Predistortion (DPD)

The DPD blocks include the DPD function, TX equalization, and the envelope tracking (ET) function. The GC533x supports two modes of operation, depending on signal bandwidth and desired DPD correction capability: high-performance (HP) mode and high-bandwidth (HB) mode. For 5× DPD expansion bandwidth (fifth-order DPD correction), the following signal bandwidths and number of streams can be supported.

High-performance DPD mode

- 1 TX stream at 62 {74} MHz
- 2 TX streams at 31 {37} MHz each
- 4 TX streams at 15.5 {18.5} MHz each

This mode provides more extensive nonlinear correction or longer DPD memory and is suitable for the most-difficult and high-performance DPD requirements.

High-bandwidth DPD mode

- 1 TX stream at 62 {74} MHz
- 2 TX streams at 62 {74} MHz each
- 4 TX streams at 31 {37} MHz each

This mode provides excellent DPD correction for most DPD requirements.

The TX equalizer is a complex equalizer and is configurable from 17 to 34 taps, depending on the DPD mode of operation. In HP modes, the number of taps may be up to 34. In HB modes, the number of taps may be up to 17. Contact the TI factory for additional details.

The predistortion correction terms are computed by an external processor (e.g., TI TMS320C6748 DSP) based on reference-input and PA-feedback data captured in the GC533x capture buffers. The external processor reads the captured data buffers from the GC533x and writes back the newly computed DPD correction terms on a continuous basis.

DPD – Envelope Tracking (ET) Mode

The ET block provides a 10-, 12-, or 14-bit real digital word, at a rate up to 155 MSPS, that is proportional to the peak envelope signal of the composite TX stream either before or after the DPD function. The ET block includes fixed and fractional delay adjustments and a LUT to provide nonlinear shaping to the ET waveform. The GC533x can provide one or two ET outputs along with the corresponding one or two TX signal stream outputs. The ET outputs use one of the LVDS DAC ports and have two interface format modes:

- a. One or two antenna streams. One antenna stream per port, with interleaved MSB half-word and LSB half-word. The port can be configured as 7-, 6-, or 5-bit DDR data (see [Table 14](#) and [Figure 18](#)), plus clock (maximum clock rate of 155 MHz in this mode). In all three cases, the 16-bit internal data is rounded to the specified 14, 12, or 10 bits. Format on the DDR data port for the three cases is:
 - 14-bit: [13:7], then [6:0]
 - 12-bit: [11:6], then [5:0]
 - 10-bit: [9:5], then [4:0]
- b. One antenna stream only. One antenna stream per port. The port can be configured as 14-, 12-, or 10-bit SDR data (see [Figure 18](#)), plus clock (maximum clock rate of 155 MHz in this mode). In all three cases, the 16-bit internal data is rounded to the specified 14, 12, or 10 bits.

Note that clock out may have a few hundred ps of jitter and is not suitable for directly driving the ET modulator DAC. The clock for the ET modulator DAC should come directly from a TI CDC clock chip, which is already on the board to provide clock sources.

TX IF Sub-Chip

The TX IF sub-chip includes a bulk upconverter (BUC), four IF mixer/NCO blocks, and TX stream MUX and SUM.

The BUC block has interpolations of 1 \times , 1.5 \times , 2 \times , 3 \times , and 4 \times . In the DPD high-band width mode, the 2 \times interpolation from the BUC is routed to the DPD input. In the high-bandwidth mode, BUC interpolation is not used after DPD. In the DPD high-performance mode, BUC interpolation is dependent on the configuration.

There are four parallel NCO/MIX blocks to allow frequency translation of each composite TX stream. The NCO is 48 bits and is referenced to the TX output rate. The NCO/MIX block can be used in either HP or HB modes; however, using the mixer reduces the DPD expansion bandwidth by the amount of frequency translation.

The TX stream MUX and SUM block allows summing of TX streams to create composite TX streams.

TX DAC Formatter

The DAC output consists of two 20-pair LVDS blocks that can be configured by the DAC formatter block for several TI DACs and system configurations. The formatter can support up to 8 DACs for 4 TX streams in complex mode. The DAC formatter block supports the TI DAC5682, DAC328x, and DAC348x families. [Table 5](#) illustrates the pin connections the different DAC and envelope [ET] modulator types.

Table 5. GC533x DAC Interface Pin Map

GC533x	328x (ET)	3482 Byte	5682	3484	3482 Word
TXA0	P1-d7	P1-d7	P1-sync	P1-sync	P1-sync
TXA1	P1-d6	P1-d6	P1-d15	P1-d15	P1-d15
TXA2	P1-d5	P1-d5	P1-d14	P1-d14	P1-d14
TXA3	P1-d4	P1-d4	P1-d13	P1-d13	P1-d13
TXA4	P1-dataclk	P1-dataclk	P1-d12	P1-d12	P1-d12
TXA5	P1-frame	P1-frame	P1-d11	P1-d11	P1-d11
TXA6	P1-d3	P1-d3	P1-d10	P1-d10	P1-d10
TXA7	P1-d2	P1-d2	P1-d9	P1-d9	P1-d9
TXA8	P1-d1	P1-d1	P1-d8	P1-d8	P1-d8
TXA9	P1-d0	P1-d0	P1-dataclk	P1-dataclk	P1-dataclk
TXA10	P2-d7	P2-d7	NA	P1-frame	NA
TXA11	P2-d6	P2-d6	P1-d7	P1-d7	P1-d7
TXA12	P2-d5	P2-d5	P1-d6	P1-d6	P1-d6
TXA13	P2-d4	P2-d4	P1-d5	P1-d5	P1-d5
TXA14	P2-dataclk	P2-dataclk	P1-d4	P1-d4	P1-d4
TXA15	P2-frame	P2-frame	P1-d3	P1-d3	P1-d3
TXA16	P2-d3	P2-d3	P1-d2	P1-d2	P1-d2
TXA17	P2-d2	P2-d2	P1-d1	P1-d1	P1-d1
TXA18	P2-d1	P2-d1	P1-d0	P1-d0	P1-d0
TXA19	P2-d0	P2-d0	NA	P1-parity	P1-parity
TXB0	P3-d7	P3-d7	P2- sync	P2-sync	P2-sync
TXB1	P3-d6	P3-d6	P2-d15	P2-d15	P2-d15
TXB2	P3-d5	P3-d5	P2-d14	P2-d14	P2-d14
TXB3	P3-d4	P3-d4	P2-d13	P2-d13	P2-d13
TXB4	P3-dataclk	P3-dataclk	P2-d12	P2-d12	P2-d12
TXB5	P3-frame	P3-frame	P2-d11	P2-d11	P2-d11
TXB6	P3-d3	P3-d3	P2-d10	P2-d10	P2-d10
TXB7	P3-d2	P3-d2	P2-d9	P2-d9	P2-d9
TXB8	P3-d1	P3-d1	P2-d8	P2-d8	P2-d8
TXB9	P3-d0	P3-d0	P2-dataclk	P2-dataclk	P2-dataclk
TXB10	P4-d7	P4-d7	NA	P2-frame	NA
TXB11	P4-d6	P4-d6	P2-d7	P2-d7	P2-d7
TXB12	P4-d5	P4-d5	P2-d6	P2-d6	P2-d6
TXB13	P4-d4	P4-d4	P2-d5	P2-d5	P2-d5
TXB14	P4-dataclk	P4-dataclk	P2-d4	P2-d4	P2-d4
TXB15	P4-frame	P4-frame	P2-d3	P2-d3	P2-d3
TXB16	P4-d3	P4-d3	P2-d2	P2-d2	P2-d2
TXB17	P4-d2	P4-d2	P2-d1	P2-d1	P2-d1
TXB18	P4-d1	P4-d1	P2-d0	P2-d0	P2-d0
TXB19	P4-d0	P4-d0	NA	P2-parity	P2-parity

Note: P1, P2, P3, and P4 are used to identify a specific DAC port. Different ports have different timing.

RX ADC Formatter

There are three ADC input ports: two 15-pair LVDS ports (referred to as ports A and B) and one 8-pair LVDS port (referred to as port C and typically used for the DPD feedback path). Depending on the ADCs selected, these three ports can accommodate up to 17 ADCs (e.g., using two octals and a single). The formatter block can route any port to either the capture buffer block or the RX signal processing blocks. The pin connections for the ADCs are shown in [Table 6](#).

The GC533x works seamlessly with the following TI ADCs.

Single: 5400, 12-bit, 1 GSPS, may need special routing on the PCB.

5463, 12-bit, 500 MSPS, may need clock-to-data-skew special routing on the PCB.

54RF63, 12-bit, 550 MSPS, may need clock-to-data-skew special routing on the PCB.

5474, 14-bit, 400 MSPS, may need clock-to-data-skew special routing on the PCB.

5493, 16-bit, 130 MSPS

548x, 16-bit, 80-200 MSPS

612x, 12-bit, 65–250 MSPS

614x, 14-bit, 65-250 MSPS

58B18, 11-bit, 200 MSPS

414x, 14-bit, 160–250 MSPS

412x, 12-bit, 160–250 MSPS

552x, 12-bit, 170–210 MSPS

554x, 14-bit, 170–210 MSPS

5517, 11-bit, 200 MSPS

Dual:

62c15, 11-bit, 125 MSPS

62c17, 11-bit, 200 MSPS

58c28, 11-bit, 200 MSPS

62p4x, 14-bit, 65-250 MSPS

62p2x, 12-bit, 65-250 MSPS

624x, 14-bit, 65-125 MSPS

622x, 12-bit, 65-125 MSPS

Quad:

642x, 12-bit, 65–125 MSPS

644x, 14-bit, 65–125 MSPS

Octal:

527x, 12-bit, 65 MSPS

528x, 12-bit, 65 MSPS

Table 6. GC533x ADC Interface Pin Map

GC533x Pin Name	58b18 5517 4149 61B49 5547	548x 6145	58c48 42x9 64p4x 62p4x 62c15	5463 5444 5474	5400L	5400R	642x 644x	527x 528x	Two 624x
RXA0	0		0	0	[12] ⁽¹⁾	syncout	[istrobe]		
RXA1	2		2	1	11	0			
RXA2	4		4	2	10	1	d1		b1
RXA3	6	0	6	3	9	2	d0		b0
RXA4	8	2	8	4	8	3	c1		f
RXA5	10	4	10	5	7	4	c0	c0	a1
RXA6	12	6	12	6	6	5	frame	c1	a0
RXA7	clk	clk	clk	7	clk	clk	clk	clk	clk
RXA8	[14]	8	0	8	5	6	b1	c2	
RXA9		10	2	9	4	7	b0	c3	b1
RXA10		12	4	10	3	8	a1	c4	b0
RXA11		14	6	11	2	9	a0	c5	f
RXA12			8	12	1	10		c6	a1
RXA13			10	13	0	11		c7	a0
RXA14	[istrobe]	[istrobe]	12	clk	syncout	[12]		fr	clk
RXB0	0		0	0	[12]	syncout			
RXB1	2		2	1	11	0			
RXB2	4		4	2	10	1			
RXB3	6	0	6	3	9	2			
RXB4	8	2	8	4	8	3			
RXB5	10	4	10	5	7	4			
RXB6	12	6	12	6	6	5			
RXB7	clk	clk	clk	7	clk	clk			
RXB8	[14]	8	0	8	5	6			
RXB9		10	2	9	4	7			
RXB10		12	4	10	3	8			
RXB11		14	6	11	2	9			
RXB12			8	12	1	10			
RXB13			10	13	0	11			
RXB14	[istrobe]	[istrobe]	12	clk	syncout	[12]			
RXC0	0								
RXC1	2								
RXC2	4								
RXC3	6								
RXC4	8								
RXC5	10								
RXC6	12								
RXC7	clk								

(1) [] indicates assignment if pins available

Feedback Processing

The feedback path is input to RXC as a real ADC. This is captured in the capture buffer and sent to the DSP. In cases where a higher-rate real ADC (>250 Msps) or a complex feedback path is desired, for better feedback performance, one of the RX ADC inputs can be used for the feedback path, and one RX ADC input is used for the RX path. Note: both RX downconverters can still be used for the RX path, or one can be used for feedback.

The widest-band feedback is seen directly from the ADC interface to the capture buffer. Further RX processing to get the complex data to the capture buffer requires that the complex rate is one-half the DPD clock rate or lower.

RX Sub-Chips

Each of two RX sub-chips consists of the following blocks (each block may be optionally bypassed), which operate on a per-stream basis:

- DC offset cancellation
- Front-end automatic gain control (feAGC)
- Real-to-Complex (R2C) conversion
- Switch for replicating or moving streams across the four paths (per sub-chip)
- IF NCO for complex mixing (frequency translation)
- Bulk downconverter (BDC)
- Equalizer
- IQ imbalance correction

DC offset cancellation

The dc offset canceller can be programmed to integrate a number of input samples automatically, divide by a power of 2, and subtract the mean offset or a programmed offset from the input. The input can be real or complex. Each input ADC has a separate cancellation for each RX block channel.

Front-end AGC

The feAGC block is used to control the RX ADC input level by controlling an external DVGA.

The feAGC has multiple channels in each RX block:

- 1 real stream up to 4 × DPD clock rate (only use one block)
- 2 real (using both blocks) or 1 complex stream (only use one block) up to 2 × DPD clock rate each
- 4 real or 2 complex streams up to DPD clock rate each (uses both blocks)
- 8 real or 4 complex streams up to 1/2 DPD clock rate each (uses both blocks)

The feAGC has both threshold comparison and an integrated power measurement. The feAGC has an error accumulation. The error accumulation can be mapped to a specific ADC desired operating point. The integral controller outputs the DVGA value to control the ADC input. DVGA controls are mapped to the specific DVGA outputs, supporting multiple DVGA types. Multipliers in the data path can be used to compensate for external DVGA gain changes (from the feAGC output control word). A delay block aligns the gain value applied to the internal multiplier with the point in time on the data samples where the external gain change was applied. Use of this multiplier minimizes gain steps that would cause transients in the downstream digital filters and allows relative power measurements on the digital signals.

The AGC operation may be suspended during certain conditions. The internal controlled-delay AGC update and special clock gating can be used to suspend the AGC operation.

The control word outputs from the feAGC blocks are applied to external DVGA parts via the DVGA pins. There are 16 DVGA pins (3.3-V CMOS) which may be individually configured as DVGA output signals or GPIO (input or output) signals. When used as DVGA control signals, there are two modes:

- Transparent mode – parallel output words are connected directly to DVGAs that are being used in a mode without a clock or latch signal to clock-in the gain word. This is the minimum latency mode. There can be two ports of 8 bits each, three ports of 5 bits each, four ports of 4 bits each, or five ports of 3 bits each.
- Clocked mode – eight latch enable (LE) signals and one 8-bit output word. This mode allows up to eight control signals, up to 8 bits each, but with increased latency. The LE signal may be a positive or negative pulse, with programmable width.

R2C

In the real-to-complex conversion block, real signal inputs are up- or downconverted by $f_s/4$, filtered to isolate the selected sideband, and decimated by a factor of 2. Real-to-complex conversion is bypassed for complex inputs.

The rejection of the R2C decimation filter is:

- For 90% bandwidth signal, –68 dB, stop band
- For 80% bandwidth signal, –106 dB, stop band

Switch

Any of the up to eight complex RX antenna/signal inputs across both sub-chips may be switched to one or more of the up to 4 output streams of each sub-chip.

IF NCO

The NCO/mixer block generates in-phase and quadrature sinusoidal signals (cos/sin) and mixes them with the switched antenna streams to frequency-translate the RX signals. The NCO contains a 48-bit frequency word and 48-bit accumulator.

BDC

The BDC supports the following modes and sample rates at its input (across both sub-chips):

- Single – $4 \times$ DPD clock rate real, $2 \times$ DPD clock rate complex
- Dual – $2 \times$ DPD clock rate real, DPD clock rate complex
- Quad – DPD clock rate real, $1/2$ DPD clock rate complex
- Octal – $1/2$ DPD clock rate real

Total decimation factors may be 1, 2, 4, 8, or 16. The decimation filtering is achieved with the cascade of the real-to-complex filter (R2C), a fixed filter F1, and a fixed filter F2. The rejection of the F1 and F2 filters is:

- Filter F1 (decimate by 1 or 2)
 - If used, always followed by filter F2, so relaxed requirements
 - 45% bandwidth, -107 dB stopband
- Filter F2
 - Recirculated 1–3 times to provide 2, 4, or $8 \times$ decimation factor
 - 90% bandwidth, -75 dB, stop band
 - 80% bandwidth, -106 dB, stop band

Equalizer

The receive equalizer is full-complex 16-tap filter that performs the following signal-processing functions:

- Programmable spectral inversion at the input
- Equalization of analog signal paths
- Channel equalization for repeater applications
- Gain/phase/fractional delay adjust (MIMO/smart antenna support)
- Fixed dc offset compensation at the output

Independent complex coefficients for real and imaginary signal data allow full flexibility for independent equalization of the direct- and cross-IQ signal components, as well as frequency-dependent IQ gain and phase imbalance compensation. The programmable 16-bit coefficient sets (i.e., C_{ij} , C_{qq} , C_{iq} and C_{qi} , for each tap) can be updated on the fly.

IQ imbalance correction

Automatic correction of IQ imbalance is provided with a 1-tap blind adaptive algorithm. The correction coefficients also may be programmed to fixed values. This block supports programmable integration intervals and flexible gating of loop operation.

RX Distributor

The outputs from the RX sub-chips are routed to the RX distributor block, which enables arbitrary assignment of RX streams to DDC channels and blocks.

RX Baseband Output Formatter

The RX baseband (BB) output formatter block accepts data from the DDC and formats the data for output on the BB LVDS pins. A back-end AGC (beAGC) function is included that optionally adjusts the gain of each channel and provides multiple format options. There are 12 unidirectional LVDS pairs for the RX BB interface.

Back-end AGC

The beAGC function is available for receive channels from DDUC3 and DDUC2 (DDUC1 and DDUC0 may also be used for receive—with the formats as described following—but without the beAGC function). When the floating-point format is selected (described following), the beAGC is not used. For the fixed-point formats, the beAGC may be on or off. There are separate beAGC blocks associated with DDUC3 and DDUC2, and each block can process up to 12 channels. Within a block, there are two sets of control parameters. This provides support for two different signal types sharing the same DDUC block. Each channel may have a programmable-gain starting point or a fixed gain, and there is a per-channel flexible gating signal to control freeze/operate intervals for TDD signal types. The beAGC has approximately a 100 dB dynamic range. The beAGC algorithm adjusts the gain to drive the median magnitude of gain-loop output data to a target threshold value. There are four step-sizes used (two for above and two for below the threshold), depending on distance from the threshold value.

Output formatter

There are three operational modes for the RX BB output formatter: byte mode (B, 9 bits), nibble mode (N, 4 bits), and serial mode (S, 2 bits). The nibble and serial modes allow multiple BB output rates and the use of fewer pins on the interface. The GC533x can provide up to three different BB output data rates. [Table 7](#) and [Table 8](#) summarize the different modes and pin assignments for the byte, nibble, and serial modes. As can be seen in [Table 8](#), there are two data formats supported:

- Floating point (indicated with an F in the mode label; 14- or 16-bit mantissa, 4-bit exponent)
- Fixed point without gain word (16- or 18-bit options)

In [Table 8](#), BBOUT[X] is the BBOUT differential pair (assumed positive and negative connections), and BB0, BB1, and BB2 represent three different RX differential baseband input signals that can be at arbitrary rates.

[Figure 13](#) shows the BB output formats. The maximum-data-rate configurations have the DDR clock out transitioning synchronously with the data (referred to as *DDR Mode 0* in the table). At half the maximum possible data rate (referred to as *DDR Mode 1* in the table) and a quarter of the maximum possible data rate (referred to as *DDR Mode 2* in the table), the DDR clock out transitions in the middle of the data-steady time .

Table 7. RX BB Formatter Modes

MODE	Description	Total Number of Interface Pins	Maximum Complex Interface Rate per Channel N is the number of channels
1B	1 interface rate (up to 18 bits)	11 = 9 data + 1 clk + 1 sync	(Clk4/4)/N/2; maximum 125 MSPS total (for all channels)
1BF	1 interface rate (up to 16 bits) + exponent (4 bits)	10 = 8 data + 1 clk + 1 sync	(Clk4/4)/N/2; maximum 125 MSPS total (for all channels)
1N	1 interface rate (16 bits)	6 = 4 data + 1 clk + 1 sync	(Clk4/8)/N; maximum 96.15 (Nibble0), 125 (Nibble1) MSPS total
1NF	1 interface rate (14 bits) + exponent (4 bits)	6 = 4 data + 1 clk + 1 sync	(Clk4/8)/N; maximum 96.15 (Nibble0), 125 (Nibble1) MSPS total
1S	1 interface rate (16 bits)	4 = 2 data + 1 clk + 1 sync	(Clk4/16)/N; maximum 48.07 MSPS total
1SF	1 interface rate (14 bits) + exponent (4 bits)	4 = 2 data + 1 clk + 1 sync	(Clk4/16)/N; maximum 48.07 MSPS total
2N	2 interface rates (16 bits)	12 = 4 data + 1 clk + 1 sync + 4 data + 1 clk + 1 sync	(Clk4/8)/N; maximum 221.15 MSPS total
2NF	2 interface rates (14 bits) + exponent (4 bits)	12 = 4 data + 1 clk + 1 sync + 4 data + 1 clk + 1 sync	(Clk4/8)/N; maximum 221.15 MSPS total
2S	2 interface rates (16 bits)	8 = 2 data + 1 clk + 1 sync + 2 data + 1 clk + 1 sync	(Clk4/16)/N; maximum 96.15 MSPS total
2SF	2 interface rates (14 bits)+ exponent (4 bits)	8 = 2 data + 1 clk + 1 sync + 2 data + 1 clk + 1 sync	(Clk4/16)/N; maximum 96.15 MSPS total
3S	3 interface rates (16 bits)	12 = 2 data + 1 clk + 1 sync + 2 data + 1 clk + 1 sync + 2 data + 1 clk + 1 sync	(Clk4/16)/N; maximum 144.23 MSPS total
3SF	3 interface rates (14 bits)+ exponent (4 bits)	12 = 2 data + 1 clk + 1 sync + 2 data + 1 clk + 1 sync + 2 data + 1 clk + 1 sync	(Clk4/16)/N; maximum 144.23 MSPS total

Table 8. RX BB Pin Assignments

LVDS Pair BBI[11:0]	Byte Mode	Nibble Mode	Serial Mode
BBOUT[0] pos. and neg.	BB0_DATA_0	BB0_DATA_0	BB0_DATA_0
BBOUT[1] pos. and neg.	BB0_DATA_1	BB0_DATA_1	BB0_DATA_1
BBOUT[2] pos. and neg.	BB0_DATA_2	BB0_SYNC	BB0_SYNC
BBOUT[3] pos. and neg.	Spare	BB0_CLOCK	BB0_CLOCK
BBOUT[4] pos. and neg.	BB0_DATA_3	BB0_DATA_2	BB1_DATA_0
BBOUT[5] pos. and neg.	BB0_DATA_4	BB0_DATA_3	BB1_DATA_1
BBOUT[6] pos. and neg.	BB0_SYNC	BB1_SYNC	BB1_SYNC
BBOUT[7] pos. and neg.	BB0_CLOCK	BB1_CLOCK	BB1_CLOCK
BBOUT[8] pos. and neg.	BB0_DATA_5	BB1_DATA_0	BB2_DATA_0
BBOUT[9] pos. and neg.	BB0_DATA_6	BB1_DATA_1	BB2_DATA_1
BBOUT[10] pos. and neg.	BB0_DATA_7	BB1_DATA_2	BB2_SYNC
BBOUT[11] pos. and neg.	BB0_DATA_8	BB1_DATA_3	BB2_CLOCK
Number of BBdata streams	1	2	3
Number of DDR clocks to transfer 1 complex sample	2	4	8

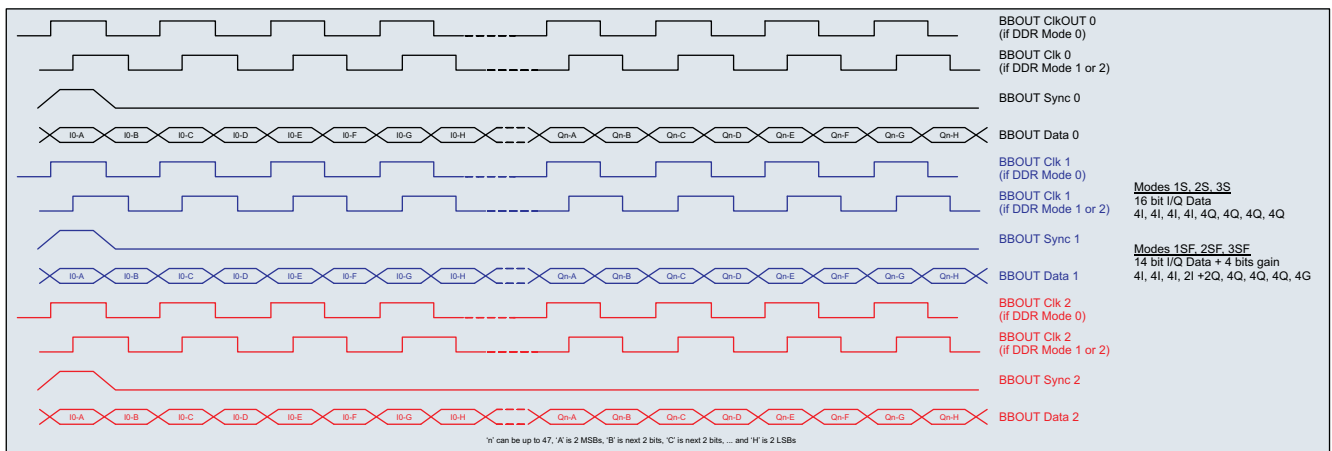
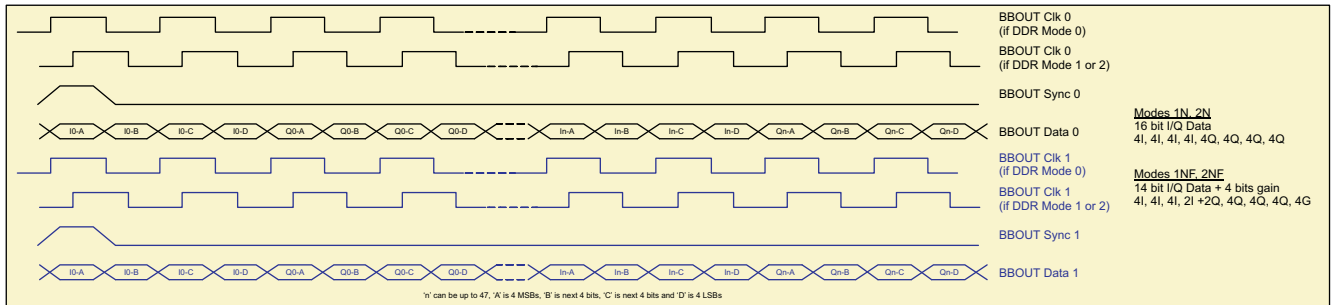
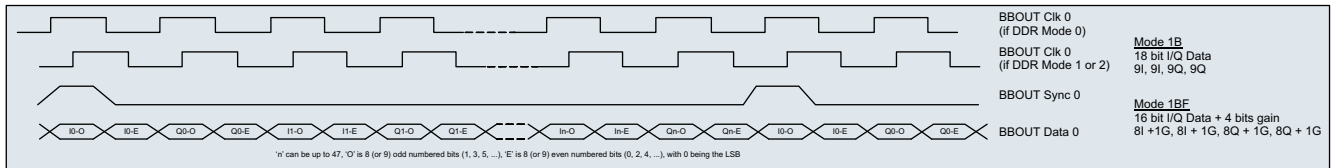

T0505-01

Figure 13. RX BB Formats

Capture Buffers

The GC533x has two capture buffers, each 4096 complex words (18-bits I, 18-bits Q) deep, which are periodically read by the external coefficient update controller (DSP) in order to optimize the DPD coefficients. The capture buffers can be configured to sample data signals at the following points in the GC533x:

- DPD HP mode input (Referred to as node A)
- DPD HP mode output (Node B)
- DPD HB mode input (Node C)
- DPD HB mode output (Node D)
- RX AB input (Node E)
- RX path 0/1 output (Node F)
- RX C (feedback) input (Node G)
- Testbus

The capture buffers can be triggered via an external sync signal, through a software trigger, or when the monitored signal exceeds the user-configurable thresholds. The capture buffers can be programmed to monitor the signal statistics continuously and only capture data when certain requirements are met, as well as to generate an interrupt when a qualified buffer is captured. This helps in selecting an optimum set of data for the DSP to use in optimizing the DPD coefficients. The capture buffers can be read by the DSP via the MPU interface.

The capture buffers also allow synchronized multi-chip data capture. For a multiple antenna system that uses more than one GC533x, a feedback signal to use in adapting DPD coefficients in multiple GC533x chips can be connected to just one of the GC533x chips. The SYNCOUT signal can be used to daisy-chain (e.g., connecting to SYNCA on the next chip) across the GC533x chips in the system. The SYNCOUT signal indicates the end of the data capture and can be used as a capture trigger in all chips.

Microprocessor (MPU) Interface

The MPU interface is designed to interface with external memory interface (EMIF) ports on TI DSPs operating in asynchronous mode. It consists of a 16-bit bidirectional data bus, an 8-bit address bus, and WEB, OEB, CEB, and EMIFENA control signals. The interface supports the TI 'C6748 as an EMIF asynchronous interface. The MPU interface has two address spaces: a paged address space and an auto-increment address space.

To enable the EMIF interface, pin EMIFENA must be set to logic high.

In an MPU write cycle, a GC533x internal MPUCLK signal is generated by NORing CEB and WEB. The MPUCLK signal goes high when both CEB and WEB are asserted and goes low as soon as either CEB or WEB is de-asserted. The MPU data is latched on the rising edge of the MPUCLK signal. For the auto-increment address spaces, the auto-increment address increments on the falling edge of the MPUCLK signal.

In an MPU read cycle, a GC533x internal MPUCLK signal is generated by NORing CEB and OEB. The MPUCLK signal goes high when both CEB and OEB are asserted and goes low as soon as either CEB or OEB is de-asserted. The MPU readback data is available soon after the rising edge of the MPUCLK signal. For the auto-increment address spaces, the auto-increment address increments on the failing edge of the MPUCLK signal.

[Figure 14](#) shows the MPU interface timing diagram. The timing specifications are provided in [Table 26](#) and [Table 27](#).

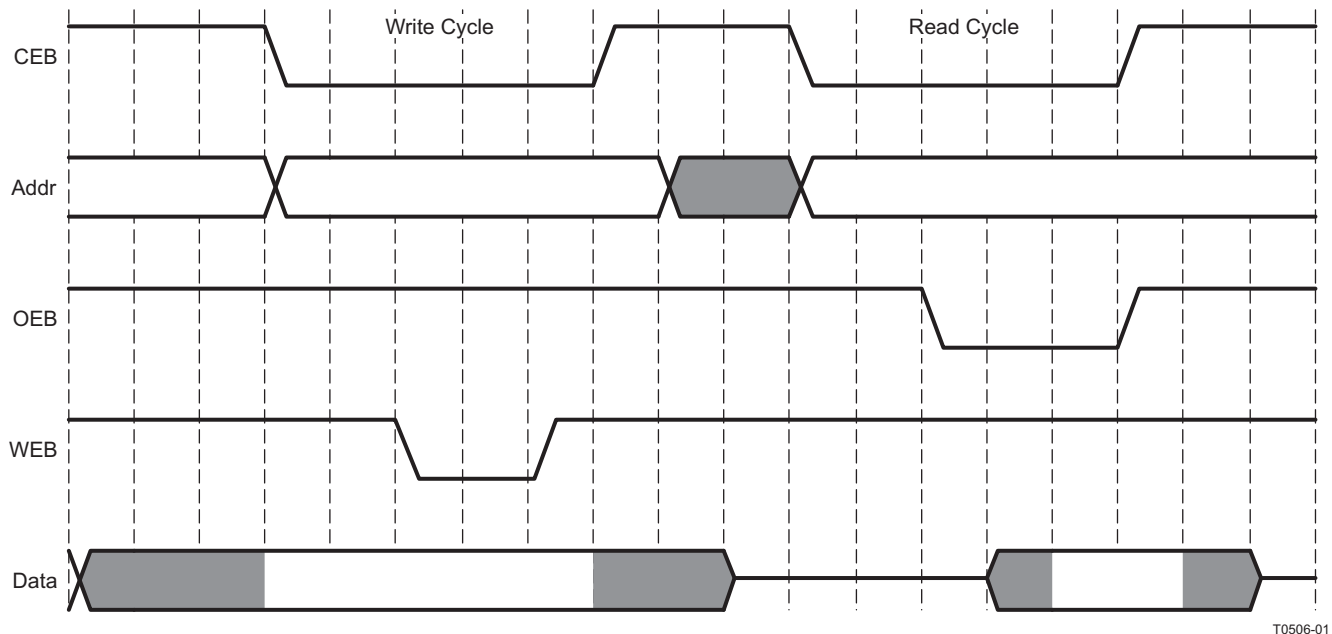

Figure 14. MPU Interface Format

Serial Peripheral Interface (SPI)

The MPU and SPI interfaces can be only enabled one at a time. EMIFENA must be set to logic low to enable the SPI interface. A three- or four-wire SPI interface is supported in the GC533x. It consists of SPIDENB, SPICLK, SPIDIO, and SPIDO-(SPARE) (output in four-wire mode) signals. See [Table 25](#) and [Figure 25](#).

JTAG Interface

The GC533x includes a five-pin JTAG interface that supports boundary scan for all CMOS pads in the chip, aside from the TESTMOD pin. The BBIN, BBOU, RX, TX, and SYNC pins are all LVDS and do not get JTAG boundary scan. **IMPORTANT NOTE:** if not using JTAG, the TRSTB signal should be grounded (or pulled to ground through $R \leq 1 \text{ k}\Omega$); otherwise, the JTAG port may take control of the pins. See [Table 24](#) and [Figure 24](#).

A BSDL file is available on the GC533x Web page.

Input and Output Syncs

The GC533x features two LVDS input syncs (SYNCA and SYNCB) and one LVDS output (SYNCOUT) user-programmable sync. These are typically used as trigger/synchronization mechanisms to activate features within the device. The input syncs can be used to trigger events such as:

- Power measurements
- DUC channel delay, mixer phase and dither
- Initializing/loading filter coefficients
- Capturing and sourcing of data in the capture buffers
- Controlling gating intervals for AGC and other adaptive loops
- Frequency NCO changes, or hopping synchronization

The SYNCA signal is used for device startup. The SYNCB signal can be used for shared feedback synchronization between multiple GC533x devices. The sync signal is active-high. The width (number of positive edges of the DPD clock) of the sync signal depends on the configuration. See the GC533x sync and MPU application note to determine the proper sync duration. A typical sync-pulse duration is four DPD clocks. The sync must be periodic, and usually starts at the beginning of the TX frame.

The output sync can be programmed to reflect triggering of specific events within the GC533x, and is primarily used to output the capture-buffer sync out signal.

Programmable Power Meters

Interval-Based Power Meter

There are three interval-based power meters which compute magnitude-squared sample values during programmable time intervals and provide the following results:

- Integrated magnitude-squared power
- Peak power
- Number of magnitude-squared values above a first threshold
- Number of magnitude-squared values above a second threshold

An interrupt bit is set when new measurement results are available. For its input, each power meter can independently select from the same set of internal node sources as the capture buffers.

Running-Average Power Meter for PA Protection

The running-average power meter monitors up to four signal streams on a single node, which is selectable from the same set of internal sources as the capture buffers. For each signal stream, it measures running-average power and counts instantaneous power values above a threshold (referred to as *peaks*). It can be used in conjunction with hardware alarms for monitoring power levels for PA protection.

The running-average power meter has the following features:

- Running average mode, with programmable forgetting factor exponent, u ($0 < u < 15$)

$$y(k+1) = (1 - 2^{-u}) \times y(k) + 2^{-u} \times |x(k)|^2,$$
 where $x(k)$ is the signal sample and $y(k)$ is the power meter output.
 Typically, one must set $u = 11$ to get 0.5-dB accuracy, $u = 14$ to get 0.1-dB accuracy.
- Peak count mode: counts the number of power values, $|x(k)|^2$, above a threshold in a specified number of samples (*window*). The number of power values, threshold, and window are all programmable.
- Flexible gating of the operation interval

Alarms

The output, $y(k)$, from the running-average power meter can be compared on an ongoing basis to programmable high and low thresholds (always positive). There are two alarms, *alarm0* and *alarm1*. Each alarm is triggered (if it is enabled) based on the programmed mode:

(0) Disabled

(1) Average power alarm. The alarm is triggered based on the following conditions:

If alarm polarity = 0 (see the *alm_polarity* register), $y(k) > \text{high_threshold}$

If alarm polarity = 1, $y(k) < \text{low_threshold}$

If alarm polarity = 2, $y(k) > \text{high_threshold}$ or $y(k) < \text{low_threshold}$

(2) Peak power alarm. The alarm is triggered based on the following conditions:

If the count of power values $|x(k)|^2 > \text{peak_threshold}$ exceeds the programmed number of samples, *peak_samples*, in a programmed window, *peak_window*

(3) The alarm is triggered if either (1) or (2) occurs.

Alarm checks are computed on a per-antenna-stream basis. Each antenna stream $y(k)$ result is compared to per-stream programmable thresholds.

Once an alarm has been triggered, the output INTERRPT pin is asserted and the appropriate (*alarm0* or *alarm1*) alarm interrupt bit is set and, for *alarm1*, a programmable action takes place. The programmable action is the same for all antenna streams, but the alarm triggering is independent for each antenna stream.

Programmable trigger actions for alarm1:

- (0) No action
- (1) Reduce gain of DPD output by programmable scale factor (programmed with stream[n].gain_reduce), only if alarm caused by $y(k) > \text{high_threshold}$ and $\text{alm_polarit} = 0$ or 2 . The gain reduction is applied at the CFR input. A control signal from the capture buffer block is used to select the programmed gain value for the multiplier at the CFR input. When the host resets this alarm by writing to the appropriate register, the control signal returns to 0 (state that is not selecting the programmed gain value).

GENERAL SPECIFICATIONS

General Electrical Characteristics

This section describes the electrical characteristics for the CMOS interfaces (DVGA, MPU, JTAG, SPI, TESTMOD, RESETB and INTERRPT) and LVDS interfaces (BBIN, BBOU, TXA, TXB, RXA, RXB, RXC, SYNC, DPDCLK) over recommended operating conditions (unless otherwise noted).

Table 9. General Electrical Characteristics, CMOS Interface

PARAMETER		TEST CONDITIONS	MIN	NOM	MAX	UNIT
V_{IL}	Voltage input low	See ⁽¹⁾			0.8	V
V_{IH}	Voltage input high	See ⁽¹⁾	2		V_{DDSHV}	V
V_{OL}	Voltage output low	$I_{OL} = 2 \text{ mA}^{(1)}$			0.5	V
V_{OH}	Voltage output high	$I_{OH} = -2 \text{ mA}^{(1)}$	2.4		V_{DDSHV}	V
$ I_{PU} $	Pullup current	$V_{IN} = 0 \text{ V}^{(1)}$	30	100	250	μA
$ I_{PD} $	Pulldown current	$V_{IN} = V_{DDSHV}^{(1)}$	30	100	250	μA
$ I_{IN} $	Leakage current	$V_{IN} = 0$ or $V_{DDSHV}^{(1)(2)}$			20	μA

- (1) Chip specifications are production tested at 90°C case temperature for the given specification. Early production lots are sample tested at -40°C.
- (2) For inputs with no pullup or pulldown, inputs with pullup and $V_{IN} = V_{DDSHV}$, inputs with pulldown and $V_{IN} = 0$, and bidirectionals in input mode in either state.

Table 10. General Electrical Characteristics, LVDS Interfaces

PARAMETER		TEST CONDITIONS	MIN	NOM	MAX	UNIT
V_{ICM}	Input common mode voltage $(V_P - V_N)/2$	See ⁽¹⁾	700		1500	mV
$ V_P - V_N $	Input differential voltage	See ⁽¹⁾	150		700	mV
R_{IN}	Input differential impedance	See ⁽¹⁾	80	92	120	Ω
V_{COM}	Output common-mode voltage	See ⁽²⁾	1125	1200	1275	mV
V_{OD}	Output differential voltage	See ⁽¹⁾	250		500	mV

- (1) Chip specifications are production tested at 90°C case temperature for the given specification. Early production lots are sample tested at -40°C.
- (2) Characteristics are determined by design.

General Switching Characteristics

The baseband interface TX has a single DDR interface input mode. The customer logic and trace routing must meet the listed t_{su} and t_h input timing.

Table 11. General Switching Characteristics, TX BB LVDS Input

PARAMETER	TEST CONDITIONS	MIN	NOM	MAX	UNIT
BASEBAND INTERFACE DDR LVDS					
$f_{CLK(BB-Serial)}$	Baseband input clock frequency	See ⁽¹⁾	500(Nibble0) 384(Nibble1)	384	MHz
$f_{CLK(BB-Nibble)}$					
$f_{CLK(BB-Byte)}$					
$f_{CLK(RXA)}$	Baseband input clock frequency, using RXA	See ⁽¹⁾		250	MHz
$t_{su(BBS0)}$	BBIN3 Clk, BBIN1:0 Data, BBIN2 Sync	See ⁽¹⁾⁽²⁾		250	ps
$t_{hi(BBS0)}$	BBIN3 Clk, BBIN1:0 Data, BBIN2 Sync	See ⁽¹⁾⁽²⁾		200	ps
$t_{su(BBS1)}$	BBIN7 Clk, BBIN5:4 Data, BBIN6 Sync	See ⁽¹⁾⁽²⁾		210	ps
$t_{hi(BBS1)}$	BBIN7 Clk, BBIN5:4 Data, BBIN6 Sync	See ⁽¹⁾⁽²⁾		250	ps
$t_{su(BBS2)}$	BBIN11 Clk, BBIN9:8 Data, BBIN10 Sync	See ⁽¹⁾⁽²⁾		240	ps
$t_{hi(BBS2)}$	BBIN11 Clk, BBIN9:8 Data, BBIN10 Sync	See ⁽¹⁾⁽²⁾		190	ps
$t_{su(BBN0)}$	BBIN3 Clk, BBIN5,4,1,0 Data, BBIN2 Sync	See ⁽¹⁾⁽²⁾		250	ps
$t_h(BBN0)$	BBIN3 Clk, BBIN5,4,1,0 Data, BBIN2 Sync	See ⁽¹⁾⁽²⁾		220	ps
$t_{su(BBN1)}$	BBIN7 Clk, BBIN11:8 Data, BBIN6 Sync	See ⁽¹⁾⁽²⁾		250	ps
$t_h(BBN1)$	BBIN7 Clk, BBIN11:8 Data, BBIN6 Sync	See ⁽¹⁾⁽²⁾		220	ps
$t_{su(BB)}$	BBIN7 Clk, BBIN11:8,5:4,2:0 Data, BBIN6 Sync	See ⁽¹⁾⁽²⁾		280	ps
$t_h(BB)$	BBIN7 Clk, BBIN11:8,5:4,2:0 Data, BBIN6 Sync	See ⁽¹⁾⁽²⁾		250	ps

- (1) Chip specifications are production tested at 90°C case temperature for the given specification. Early production lots are sample tested at -40°C.
- (2) Setup and hold times are measured from differential data crossing zero to differential clock crossing zero.

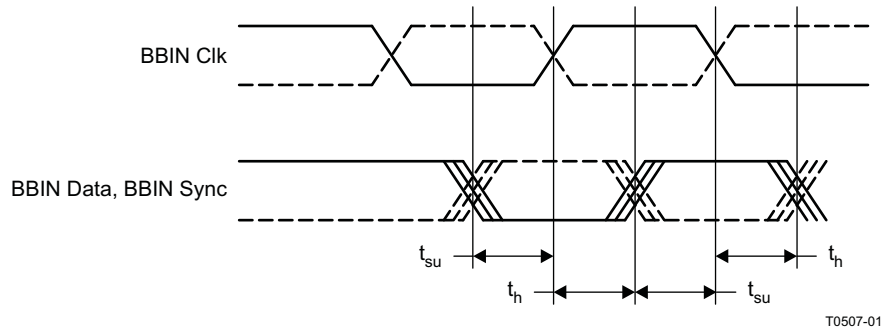

Figure 15. TX Baseband LVDS Input Timing Specifications

The BB LVDS RX outputs have three different output timing modes, DDR0, DDR1 and DDR2. DDR1 and DDR2 modes output data, and the BBclk output is centered over the data. In DDR0 mode, the data and clock are edge-aligned. Different BBOUT pins are used for clock, frame, and data pins depending on the byte, nibble, and serial modes. The DDR1 and DDR2 modes are shown in Table 12 and Figure 16. The DDR0 mode is shown in Table 13 and Figure 17. Table 12 and Figure 16. DDR1 mode is used upto a BBclk frequency of 310 MHz. DDR2 mode is used upto a BBclk frequency of 155 MHz. When the data rate is higher than 500 MHz, BBclk above 250 MHz, the operating mode is DDR0. In this mode, the clock is aligned with the output data transition. In DDR0 mode, the customer must delay the clock to meet the t_{su} and t_{hi} target for the baseband input. The t_{skw} time is measured as the relative skew for the data and frame to the clock output. This is shown in Figure 13 and Table 17.

In receive (uplink) mode, the GC5330 outputs data using the LVDS pins BBOUT. The BBOUT port may be operated in three modes, DDR0, DDR1, and DDR2.

The lowest-rate outputs use DDR2 mode, where the output clock changes on one rising edge of the internal clock and the output data changes on the subsequent rising edge. In DDR2 mode, the output bit rate (per LVDS pair) is half of the internal clock. Middle-rate outputs use DDR1 mode, where the output clock changes on the falling edge of the internal clock and the output data changes on the rising edge of the internal clock, which results in an output bit rate equal to the internal clock rate. Both DDR1 and DDR2 result in the output clock edge occurring in the middle of output data-stable time. The DDR1 and DDR2 modes are shown in Table 12 and Figure 16.

The highest-rate outputs use DDR0 mode, where both the output clock and output data change with both the rising and falling edges of the internal clock. The DDR0 output bit rate is twice the internal clock rate. DDR0 results in the clock and data changing at the same time, and typically requires extra trace length on the PC board for the clockout signal to provide the required setup time for the receiving chip. The DDR0 mode is shown in Table 13 and Figure 17.

Table 12. General Switching Characteristics, RX BB LVDS Output – DDR1, DDR2

PARAMETER		TEST CONDITIONS	MIN	NOM	MAX	UNIT
BASEBAND INTERFACE DDR LVDS						
$f_{CLK(BB-DDR2)}$	Baseband output clock frequency	See ⁽¹⁾ . Applies to BBOUT byte, nibble, or serial	155			MHz
$f_{CLK(BB-DDR1)}$			310			
$t_{skmin(BB)Serial0}$	BBOUT3 Clk, BBOUT1:0 Data, BBOUT2 Sync	See ⁽²⁾⁽³⁾	-20			ps
$t_{skmax(BB)Serial0}$	BBOUT3 Clk, BBOUT1:0 Data, BBOUT2 Sync	See ⁽²⁾⁽³⁾	350			ps
$t_{skmin(BB)Serial1}$	BBOUT7 Clk, BBOUT5:4 Data, BBOUT6 Sync	See ⁽²⁾⁽³⁾	15			ps
$t_{skmax(BB)Serial1}$	BBOUT7 Clk, BBOUT5:4 Data, BBOUT6 Sync	See ⁽²⁾⁽³⁾	310			ps
$t_{skmin(BB)Serial2}$	BBOUT11 Clk, BBOUT9:8 Data, BBOUT10 Sync	See ⁽²⁾⁽³⁾	60			ps
$t_{skmin(BB)Serial2}$	BBOUT11 Clk, BBOUT9:8 Data, BBOUT10 Sync	See ⁽²⁾⁽³⁾	300			ps
$t_{skmax(BB)Nibble0}$	BBOUT3 Clk, BBOUT5,4,1,0 Data, BBOUT2 Sync	See ⁽²⁾⁽³⁾	170			ps
$t_{skmax(BB)Nibble0}$	BBOUT3 Clk, BBOUT5,4,1,0 Data, BBOUT2 Sync	See ⁽²⁾⁽³⁾	340			ps
$t_{skmin(BB)Nibble1}$	BBOUT7 Clk, BBOUT11:8 Data, BBOUT6 Sync	See ⁽²⁾⁽³⁾	55			ps
$t_{skmax(BB)Nibble1}$	BBOUT7 Clk, BBOUT11:8 Data, BBOUT6 Sync	See ⁽²⁾⁽³⁾	305			ps
$t_{skmin(BB)Byte}$	BBOUT7 Clk, BBOUT11:8,5:4,2:0 Data, BBOUT6 Sync	See ⁽²⁾⁽³⁾	250			ps
$t_{skmax(BB)Byte}$	BBOUT7 Clk, BBOUT11:8,5:4,2:0 Data, BBOUT6 Sync	See ⁽²⁾⁽³⁾	255			ps

- (1) Chip specifications are production tested at 90°C case temperature for the given specification. Early production lots are sample tested at -40°C.
- (2) Skew measured for RX BBOUT data and frame signals, relative to the BBclk signal at zero crossing. BBclk is measured at threshold crossing. Lab measurement +signal → 50 Ω → Vcommon → 50 Ω → -signal. Vcommon has a 0.01-μF filter capacitor to GND. Differential probe used for measurement.
- (3) t_{su} calculation: 1/4 BBclk period - t_{skmin} ; t_h calculation: 1/4 BBclk period - t_{skmax}

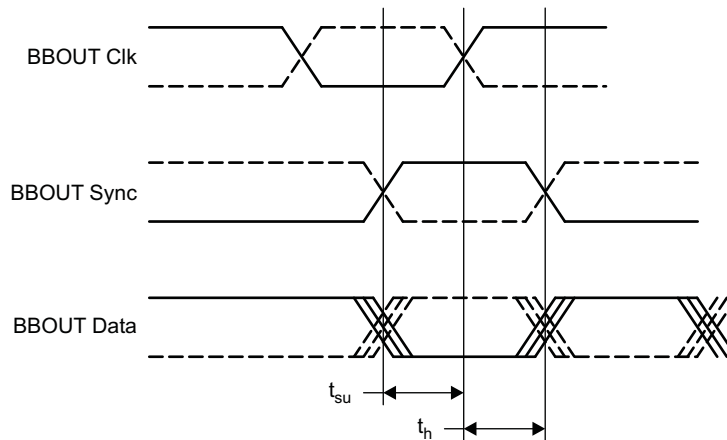

T0508-01

Figure 16. RX Baseband LVDS DDR1, DDR2 Output Timing Specifications

Table 13. General Switching Characteristics, RX BB LVDS Output – DDR0

PARAMETER		TEST CONDITIONS	MIN	NOM	MAX	UNIT
BASEBAND INTERFACE DDR LVDS						
$f_{CLK(Byte)}$	Baseband output clock frequency	See ⁽¹⁾			384	MHz
$f_{CLK(Nibble0)}$					384	MHz
$f_{CLK(Nibble1)}$					500	MHz
$f_{CLK(Serial)}$					384	MHz
$t_{skmax(BB)Serial0}$	BBOUT3 Clk, BBOUT1:0 Data, BBOUT2 Sync	See ⁽²⁾⁽³⁾		-60		ps
$t_{skmin(BB)Serial0}$	BBOUT3 Clk, BBOUT1:0 Data, BBOUT2 Sync	See ⁽²⁾⁽³⁾⁽⁴⁾		400		ps
$t_{skmax(BB)Serial1}$	BBOUT3 Clk, BBOUT1:0 Data, BBOUT2 Sync	See ⁽²⁾⁽³⁾		-130		ps
$t_{skmin(BB)Serial1}$	BBOUT3 Clk, BBOUT1:0 Data, BBOUT2 Sync	See ⁽²⁾⁽³⁾⁽⁴⁾		500		ps
$t_{skmax(BB)Serial2}$	BBOUT7 Clk, BBOUT5:4 Data, BBOUT6 Sync	See ⁽⁵⁾⁽⁶⁾		-45		ps
$t_{skmin(BB)Serial2}$	BBOUT7 Clk, BBOUT5:4 Data, BBOUT6 Sync	See ⁽⁵⁾⁽⁶⁾⁽⁷⁾		425		ps
$t_{skmax(BB)Nibble0}$	BBOUT3 Clk, BBOUT5,4,1,0 Data, BBOUT2 Sync	See ⁽⁵⁾⁽⁶⁾		0		ps
$t_{skmin(BB)Nibble0}$	BBOUT3 Clk, BBOUT5,4,1,0 Data, BBOUT2 Sync	See ⁽⁵⁾⁽⁶⁾⁽⁷⁾		400		ps
$t_{skmax(BB)Nibble1}$	BBOUT7 Clk, BBOUT11:8 Data, BBOUT6 Sync	See ⁽⁵⁾⁽⁶⁾		10		ps
$t_{skmin(BB)Nibble1}$	BBOUT7 Clk, BBOUT11:8 Data, BBOUT6 Sync	See ⁽⁵⁾⁽⁶⁾⁽⁷⁾		460		ps
$t_{skmax(BB)Byte}$	BBOUT7 Clk, BBOUT11:8,5:4,2:0 Data, BBOUT6 Sync	See ⁽⁵⁾⁽⁶⁾		0		ps
$t_{skmin(BB)Byte}$	BBOUT7 Clk, BBOUT11:8,5:4,2:0 Data, BBOUT6 Sync	See ⁽⁵⁾⁽⁶⁾⁽⁷⁾		480		ps

- (1) Chip specifications are production tested at 90°C case temperature for the given specification. Early production lots are sample tested at -40°C.
- (2) Skew measured for RX BBOUT data and frame signals, relative to the BBclk signal at zero crossing. BBclk is measured at threshold crossing. Lab measurement +signal → 50 Ω → Vcommon → 50 Ω → -signal. Vcommon has a 0.01-μF filter capacitor to GND. Differential probe used for measurement.
- (3) The customer interface design modifies the trace lengths based on the desired receiver timing and clock delays.
- (4) $t_{su} = -t_{skmax}$; $t_{hold} = 1/4$ BBclk period - t_{skmin} .
- (5) Skew measured for RX BBOUT data and frame signals, relative to the BBclk signal at zero crossing. BBclk is measured at threshold crossing. Lab measurement +signal → 50 Ω → Vcommon → 50 Ω → -signal. Vcommon has a 0.01-μF filter capacitor to GND. Differential probe used for measurement.
- (6) The customer interface design modifies the trace lengths based on the desired receiver timing and clock delays.
- (7) $t_{su} = -t_{skmax}$; $t_{hold} = 1/4$ BBclk period - t_{skmin} .

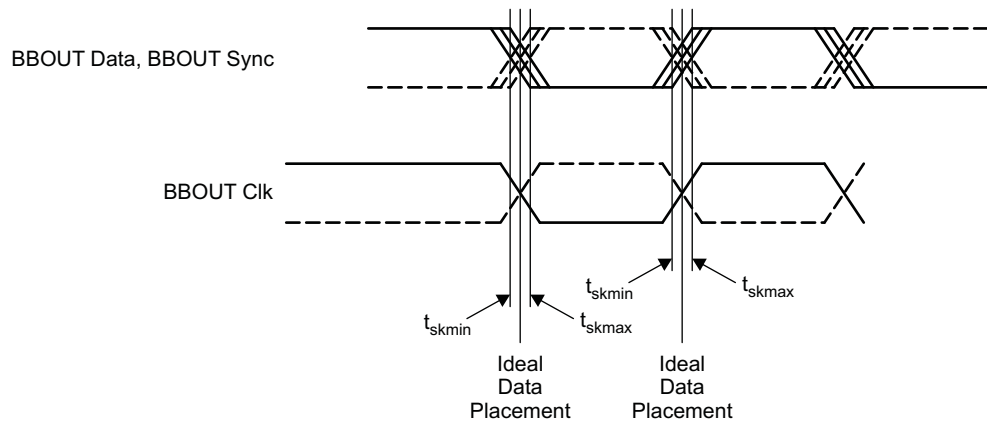

T0509-01

Figure 17. RX Baseband LVDS DDR0 Output Timing Specifications

The DAC TX interface has a 40-signal output bus. The DAC TX bus can provide 4-byte-wide or 2-word-wide interfaces. Table 5 shows the different DAC devices that can be connected to the TX output ports. The DAC TX interface has two styles of clock output, one where the DDR clock is centered over the output data-stable time, and one where the clock transition is aligned with the data transition. If the output clock rate is greater than 500 MHz, the GC533x must be configured for clock transition aligned with the data transition. Depending on the DAC type selected, the clock, frame, and data for the DAC may require a trace routing delay for proper alignment. See Table 14, Table 15, and Table 16.

Table 14. TX DAC and Envelope Modulator Characteristics

DAC or Envelope Modulator Type	Timing Model	DAC Data Rate	Table Number	Figure Number
DAC3282, 3283 byte-envelope modulator	Clock centered over data	<1000 Mbyte/s	Table 15	Figure 18
DAC3282, 3283 byte-envelope modulator	Clock aligned with data at GC533x, routing provides timing skew for clock centered over data	≥ 1000 Mbyte/s	Table 16	Figure 19
DAC3484, 3482 word	Clock centered over data	<1000 Mword/s	Table 15	Figure 18
DAC3484, 3482 word	Clock aligned with data at GC533x, routing provides timing skew for clock centered over data	≥ 1000 Mword/s	Table 16	Figure 19
DAC5682	Clock aligned with data at GC533x. PC board routing may be required to provide some timing skew for optimum performance.	All	Table 16	Figure 19

Table 15. TX DAC Clock Centered Over Data Switching Characteristics (See Table 5 for Connections)

PARAMETER		TEST CONDITIONS	MIN	MAX	UNIT
DDR LVDS					
$f_{CLK(DAC)}$	DAC output clock frequency	See ⁽¹⁾		620	MHz
CLOCK	DATA	TEST CONDITIONS	MIN SKEW	MAX SKEW	UNIT
TXA4	TXA9:5, 3:0	See ⁽²⁾⁽³⁾	-190	139	ps
TXA14	TXA19:15, 13:10	See ⁽²⁾⁽³⁾	-241	205	ps
TXA9	TXA19:10, 8:0	See ⁽²⁾⁽³⁾	-200	155	ps
TXB4	TXB9:5, 3:0	See ⁽²⁾⁽³⁾	-169	238	ps
TXB14	TXB19:15, 13:10	See ⁽²⁾⁽³⁾	-198	146	ps
TXB9	TXB19:10, 8:0	See ⁽²⁾⁽³⁾	-145	235	ps

- (1) Chip specifications are production tested at 90°C case temperature for the given specification. Early production lots are sample tested at -40°C.
- (2) Skew measured from DAC DATA desired P/N crossing to DATA P/N crossing. A negative skew is when the data arrives prior to the clock.
- (3) $t_{su} = 1/4$ DAC clock period - Max. Skew, $t_h = 1/4$ DAC clock period + Min. Skew

Table 16. TX DAC Clock Aligned With Data Switching Characteristics (See Table 5 for Connections)

PARAMETER		TEST CONDITIONS	MIN	MAX	UNIT
DDR LVDS					
$f_{CLK(DAC)}$	DAC output clock frequency	See ⁽¹⁾		620	MHz
CLOCK	DATA	TEST CONDITIONS	MIN SKEW	MAX SKEW	UNIT
TXA4	TXA9:5, 3:0	See ⁽²⁾	-190	139	ps
TXA14	TXA19:15, 13:10	See ⁽²⁾	-241	205	ps
TXA9	TXA19:10, 8:0	See ⁽²⁾	-200	155	ps
TXB4	TXB9:5, 3:0	See ⁽²⁾	-169	238	ps
TXB14	TXB19:15, 13:10	See ⁽²⁾	-198	146	ps
TXB9	TXB19:10, 8:0	See ⁽²⁾	-145	235	ps

- (1) Chip specifications are production tested at 90°C case temperature for the given specification. Early production lots are sample tested at -40°C.
- (2) Skew measured from DAC DATA desired P/N crossing to DATA P/N crossing. A negative skew is when the data arrives prior to the clock.

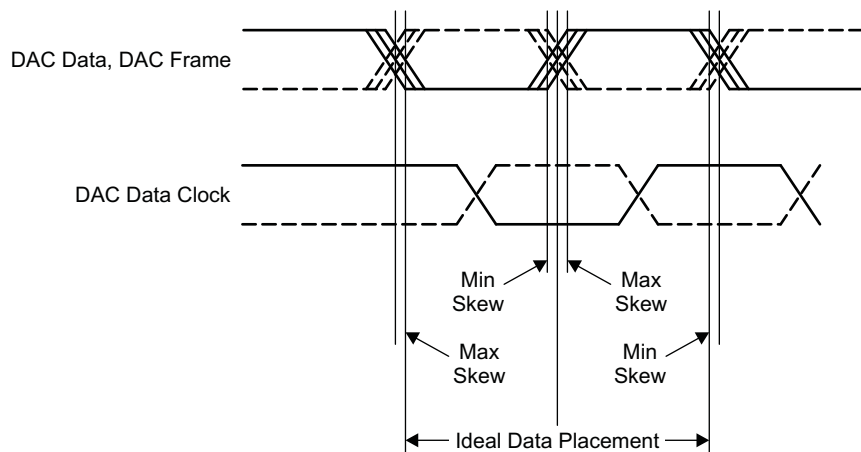

T0510-01

Figure 18. TX LVDS Timing Specifications (TXA and TXB) (DACCLK Centered Over Data)

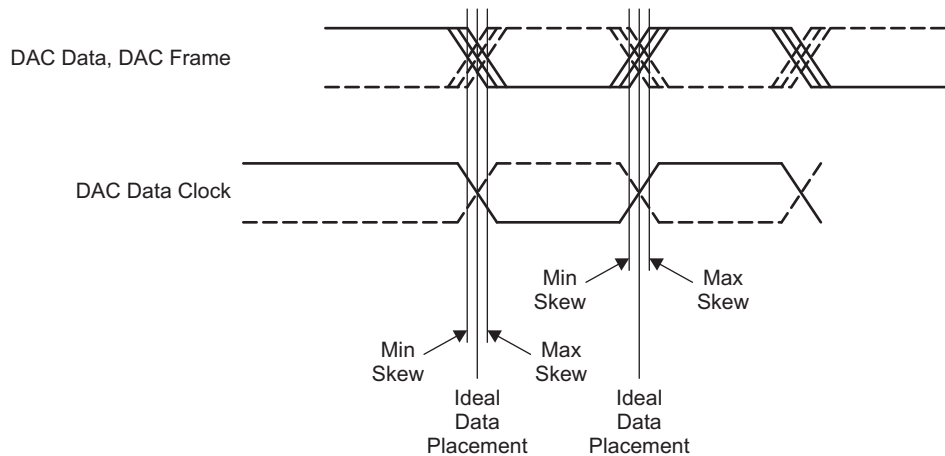

T0511-01

Figure 19. TX LVDS Timing Specifications (TXA and TXB) (DACCLK Aligned With Data)

The envelope modulator interface uses the same pins as the DAC interface. The ET connections are shown in [Table 5](#). The ET modulator timing is listed in [Table 15](#).

Data is output most-significant byte (half-word) first with the rising edge of the clockout in the middle of data-stable time, then least-significant byte (half-word) with the falling edge of the clockout in the middle of the data-stable time.

The ADC output interface has two types of timing, based on the clock centered over the data, or clock edge-aligned with the data. The GC533x only processes clock centered over the data. Each ADC type is characterized by the data and clock alignment, in [Table 17](#), from which the proper table and timing diagram can be determined as follows: ADC W7 in [Table 18](#) and [Figure 20](#); ADC W14 in [Table 19](#) and [Figure 21](#); and ADC B7 in [Table 20](#) and [Figure 20](#). Note: The general ADC routing is to align the clock and data traces with a common routing delay. For the ADS5463 and ADS5474 the clock trace must be adjusted in length to meet the system timing design.

Note: when RXA is used as a baseband interface, the specification is shown in [Table 17](#). The table shows a sampling of ADCs released at publication time. If the clock is not centered, the pc board may require added routing delay to the clock out to satisfy the setup time requirements. See (*) in [Table 17](#).

W7 – word-wide ADC interface, clock on bit 7

W14 – word-wide ADC interface, clock on bit 14

B7 – byte-wide ADC interface, clock on bit 7

B14 – byte-wide ADC interface, clock on bit 14

Table 17. General LVDS ADC Interface Table

ADC Type	Bits per Rail	Clock Centered	ADC Format	ADC Input Timing Table	ADC Figure
ADS5400	1	Yes	W7	Table 18	Figure 20
ADS54RF63 (*)	1	No	W14	Table 19	Figure 20
ADS5463 (*)	1	No	W14	Table 19	Figure 20
ADS5474 (*)	1	No	W14	Table 19	Figure 20
RXA as baseband TX input	2	Yes	Baseband format – W14	Table 21	Figure 20
ADS61xx, ADS41xx, ADS62pxx	2	Yes	B7	Table 20	Figure 20
ADS55xx	2	Yes	B7, W7	Table 20Table 18	Figure 20
ADS58B18	2	Yes	B7, W7	Table 20Table 18	Figure 20
ADS58B28, ADS62c1x	2	Yes	B7, W7	Table 20Table 18	Figure 20
ADS64xx	6 or 7	Yes	W7	Table 18	Figure 21
ADS52xx	12 or 14	Yes	W7	Table 18	Figure 21

Table 18. RX ADC-W7 Switching Characteristics

PARAMETER	TEST CONDITIONS	MIN	NOM	MAX	UNIT
$f_{CLK(ADC)}$ RX input clock frequency, ADCA7 Clk	See (1)			620	MHz
$t_{su(ADC,A)}$ Input data setup time on port A before ADCA7 Clk transition	See (1)(2)	260			ps
$t_{h(ADC,A)}$ Input data hold time on port A after ADCA7 Clk transition	See (1)(2)	170			ps
$t_{su(ADC,B)}$ Input data setup time on port B before ADCB7 Clk transition	See (1)(2)	260			ps
$t_{h(ADC,B)}$ Input data hold time on port B after ADCB7 Clk transition	See (1)(2)	140			ps

- (1) Chip specifications are production tested at 90°C case temperature for the given specification. Early production lots are sample tested at -40°C.
 (2) Setup and hold times apply to data and appropriate ADC Clk, respectively. Timing is measured from ADC Clk threshold crossing.

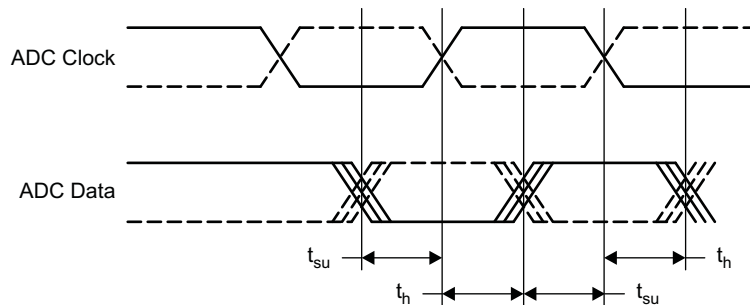

T0512-01

Figure 20. RX ADC LVDS Timing Specifications (RXA and RXB)

Table 19. RX ADC-W14 Switching Characteristics

PARAMETER		TEST CONDITIONS	MIN	NOM	MAX	UNIT
$f_{\text{CLK(ADC)}}$	RX input clock frequency ADCA14 Clk, ADCB14 Clk	See (1)			620	MHz
$t_{\text{su(ADC,A)}}$	Input data setup time on port A before ADCA14 Clk transition	See (1)(2)	160			ps
$t_{\text{h(ADC,A)}}$	Input data hold time on port A after ADCA14 Clk transition	See (1)(2)	200			ps
$t_{\text{su(ADC,B)}}$	Input data setup time on port B before ADCB14 Clk transition	See (1)(2)	180			ps
$t_{\text{h(ADC,B)}}$	Input data hold time on port B after ADCB14 Clk transition	See (1)(2)	220			ps

- (1) Chip specifications are production tested at 90°C case temperature for the given specification. Early production lots are sample tested at –40°C.
- (2) Setup and hold times apply to data and appropriate ADC Clk, respectively. Timing is measured from ADC Clk threshold crossing.

Table 20. RX ADC-B7, B14 Switching Characteristics

PARAMETER		TEST CONDITIONS	MIN	NOM	MAX	UNIT
$f_{\text{CLK(ADC-AB)}}$	RX input clock frequency, ADCA7 Clk, ADCB7 Clk	See (1)			620	MHz
$f_{\text{CLK(ADC-C)}}$	RX input clock frequency, ADCC7 Clk	See (1)			620	MHz
$t_{\text{su(ADC,A)}}$	Input data setup time on port A before ADCA7 Clk transition	See (1)(2)	260			ps
$t_{\text{h(ADC,A)}}$	Input data hold time on port A after ADCA7 Clk transition	See (1)(2)	160			ps
$t_{\text{su(ADC,B)}}$	Input data setup time on port B before ADCB7 Clk transition	See (1)(2)	170			ps
$t_{\text{h(ADC,B)}}$	Input data hold time on port B after ADCB7 Clk transition	See (1)(2)	140			ps
$t_{\text{su(ADC,C)}}$	Input data setup time on port C before ADCC7 Clk transition	See (1)(2)	290			ps
$t_{\text{h(ADC,C)}}$	Input data hold time on port C after ADCC7 Clk transition	See (1)(2)	150			ps
$t_{\text{su(ADC,A)}}$	Input data setup time on port A before ADCA14 Clk transition	See (1)(2)	130			ps
$t_{\text{h(ADC,A)}}$	Input data hold time on port A after ADCA14 Clk transition	See (1)(2)	200			ps
$t_{\text{su(ADC,B)}}$	Input data setup time on port B before ADCB14 Clk transition	See (1)(2)	170			ps
$t_{\text{h(ADC,B)}}$	Input data hold time on port B after ADCB14 Clk transition	See (1)(2)	240			ps

- (1) Chip specifications are production tested at 90°C case temperature for the given specification. Early production lots are sample tested at –40°C.
- (2) Setup and hold times apply to data and appropriate ADC Clk, respectively. Timing is measured from ADC Clk threshold crossing.

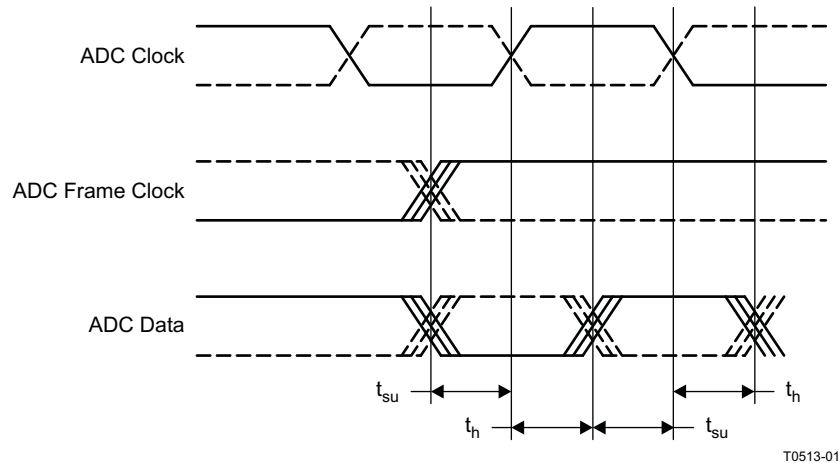

Figure 21. RX ADC LVDS Timing Specifications (RXA and RXB)

Table 21. RXA-BB Switching Characteristics

PARAMETER	TEST CONDITIONS	MIN	NOM	MAX	UNIT
$f_{CLK(BB-A)}$	RX input clock frequency	See ⁽¹⁾		250	MHz
$t_{su(BB-A)}$	Input data setup time on port A before ADCA Clk transition	See ⁽¹⁾⁽²⁾	160		ps
$t_h(BB-A)$	Input data hold time on port A after ADCA Clk transition	See ⁽¹⁾⁽²⁾	200		ps

- (1) Chip specifications are production tested at 90°C case temperature for the given specification. Early production lots are sample tested at -40°C.
- (2) Setup and hold times apply to data and appropriate ADC Clk, respectively. Timing is measured from ADC Clk threshold crossing.

Table 22. DPD Clock and Sync A,B Switching Characteristics⁽¹⁾

PARAMETER	TEST CONDITIONS	MIN	NOM	MAX	UNIT
$f_{CLK(DPD)}$	DPD input clock frequency	See ⁽²⁾		310 {370}	MHz
$f_{CLK(BB)}$	BB internal clock frequency	See ⁽¹⁾		250 {290}	MHz
$t_{DUTY-CYCLE}$	DPD input clock duty cycle	See ⁽³⁾	40%	60%	
$f_{CLK (JITTERMS-DPD)}$	DPD clock input jitter	See ⁽³⁾		2.5%	
$t_{su(SYNCA)}$	Input data setup time before $f_{CLK}\uparrow$	See ⁽²⁾	0.25		ns
$t_h(SYNCA)$	Input data hold time after $f_{CLK}\uparrow$	See ⁽²⁾	0.1		ns
$t_{su(SYNCB)}$	Input data setup time before $f_{CLK}\uparrow$	See ⁽²⁾	0.35		ns
$t_h(SYNCB)$	Input data hold time after $f_{CLK}\uparrow$	See ⁽²⁾	0.05		ns

- (1) The PLL output ranges are 400–1000 MHz. These are configuration dependent but related to the DPDCLK frequency. The cmd5330 software automatically checks these limits when compiling a configuration.
- (2) Chip specifications are production tested at 90°C case temperature for the given specification. Early production lots are sample tested at -40°C.
- (3) Specification is from the PLL specification and is not production tested.

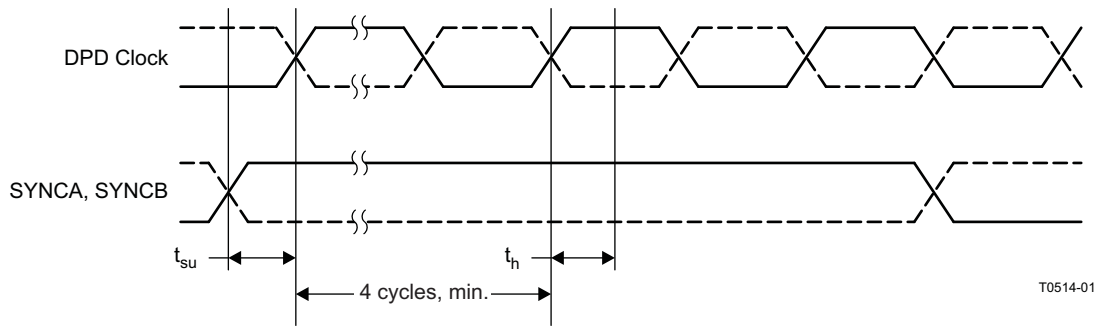

Figure 22. SYNCA, SYNCB Timing to DPD Clock

Table 23. DPD Clock and Sync Out Switching Characteristics

PARAMETER	TEST CONDITIONS	MIN	NOM	MAX	UNIT
$t_{d(\text{SYNCOut})}$	Data valid after DPD clock	See (1)		0.95	ns
$t_{HO(\text{SYNCOut})}$	Data held valid after next DPD clock	0.3			ns

(1) Chip specifications are production tested at 90°C case temperature for the given specification. Early production lots are sample tested at -40°C.

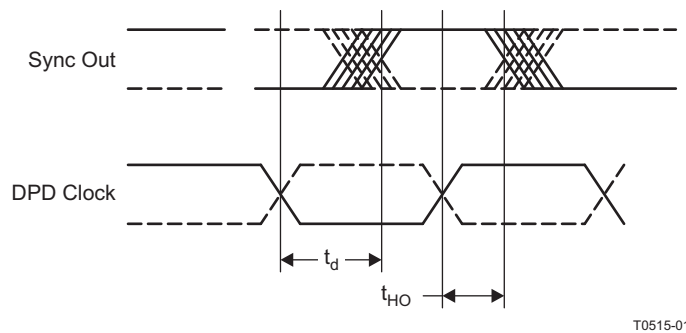

Figure 23. Sync Out Timing to DPD Clock

The JTAG test connections are used with the CMOS signals for board interconnection tests. The TRSTB pin must be toggled low, or low initially. If JTAG is not used, the TRSTB signal should be GROUNDed or tied to GND through < 1 kΩ resistance. TRSTB should be 0 for normal operation.

Table 24. JTAG Switching Characteristics

PARAMETER	TEST CONDITIONS	MIN	MAX	UNIT
f_{TCK}	JTAG clock frequency		50	MHz
t_{TCKL}	JTAG clock low period	See (1)	10	ns
t_{TCKH}	JTAG clock high period	See (1)	10	ns
$t_{\text{su(TDI,TMS)}}$	Input data setup time before $f_{\text{TCK}}\uparrow$	See (1)	7	ns
$t_{\text{H(TDI,TMS)}}$	Input data hold time after $f_{\text{TCK}}\uparrow$	See (1)	1.5	
t_{d}	Output data delay from $f_{\text{TCK}}\downarrow$	See (1)	10	ns
$t_{\text{OHD(TDO)}}$	Previous data valid from $f_{\text{TCK}}\downarrow$	See (1)	2	ns

(1) Chip specifications are production tested at 90°C case temperature for the given specification. Early production lots are sample tested at -40°C.

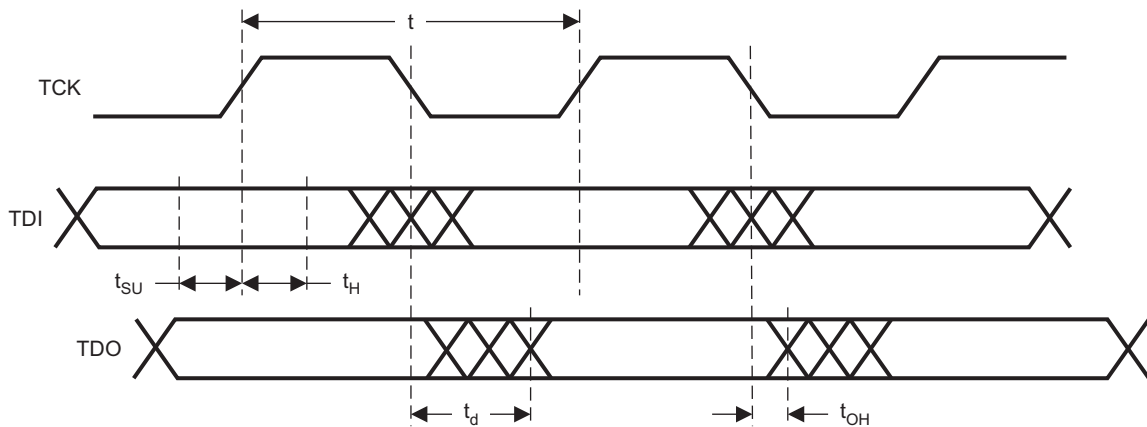

T0289-02

Figure 24. JTAG Timing Specifications

The SPI programming interface is active only when EMIFENA is 0. There are both three-wire and four-wire SPI interfaces; the SPIDO(SPARE) is the fourth wire for SPI data output.

Table 25. SPI Switching Characteristics

PARAMETER	TEST CONDITIONS	MIN	NOM	MAX	UNIT
$t_{su(DENB)}$	Enable setup time before SPI CLK \uparrow	Valid for SPIDENB, see ⁽¹⁾	5		ns
$t_{su(DI)}$	Data setup time before SPI CLK \uparrow	Valid for SPIDIO, see ⁽¹⁾	5		ns
$t_{h(DI)}$	Input data hold time after CLK \uparrow	Valid for SPIDIO, see ⁽¹⁾	0.6		ns
$t_{d(DO)}$	Output data delay from $f_{TCK}\downarrow$	Valid for SPIDIO, see ⁽²⁾		8	ns
$t_{d(DO1)}$	Output data delay from $f_{TCK}\downarrow$	Valid for SPIDO(SPARE), see ⁽²⁾		8	ns
$f_{clk\ SPI}$	SPI clock frequency	See ⁽¹⁾		50	MHz

- (1) Chip specifications are production tested at 90°C case temperature for the given specification. Early production lots are sample tested at -40°C.
- (2) The SPI data output in three-wire mode comes from SPIDIO; in four-wire mode the output is from SPIDO(SPARE).

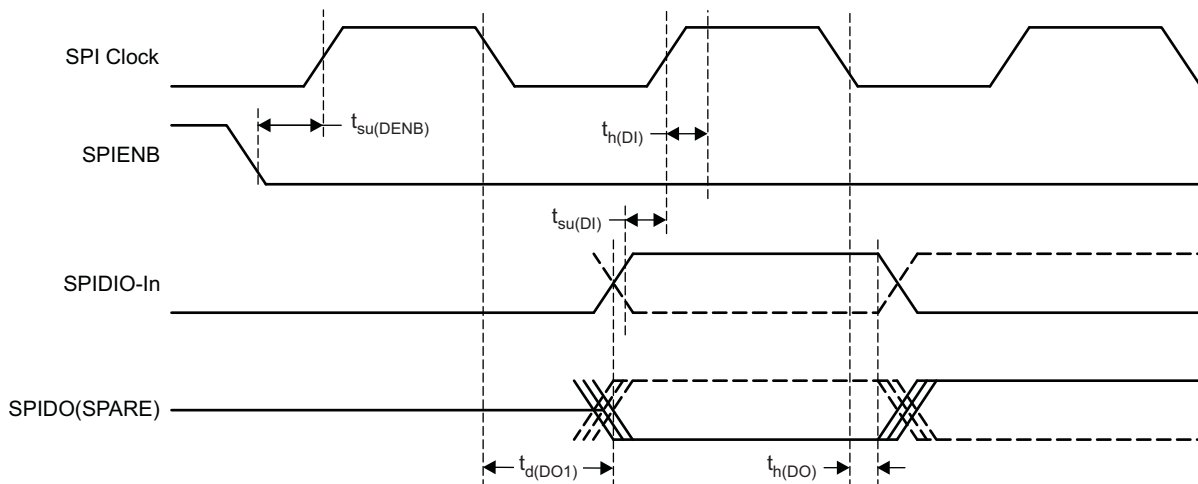

T0516-01

Figure 25. SPI Timing Specifications

Table 26. MPU Switching Characteristics (READ)

PARAMETER		TEST CONDITIONS	MIN	MAX	UNIT
$t_{su(RD)}$	CEB and ADDR setup time to \downarrow OEB	See ⁽¹⁾	1.5		ns
$t_{dly(RD)}$	Data valid time after \downarrow OEB	See ⁽¹⁾		15	ns
$t_{h(RD)}$	CEB and ADDR hold time to \uparrow OEB	See ⁽¹⁾	2.5		ns
$t_{HIGH(RD)}$	Time OEB must remain HIGH between READS	See ⁽¹⁾	6		ns
$t_{z(RD)}$	Data goes to high-impedance state after \uparrow OEB or \uparrow CEB	See ⁽²⁾		5	ns
$t_{cycle(RD)}$	Time between READS	See ⁽¹⁾	21		ns
$t_{oh(RD)}$	Time after OEB \uparrow that data is valid	See ⁽²⁾		TBD	ns

- (1) Chip specifications are production tested at 90°C case temperature for the given specification. Early production lots are sample tested at -40°C.
 (2) Bench tested for output start changing after releasing strobe with a 50-Ω load on the output

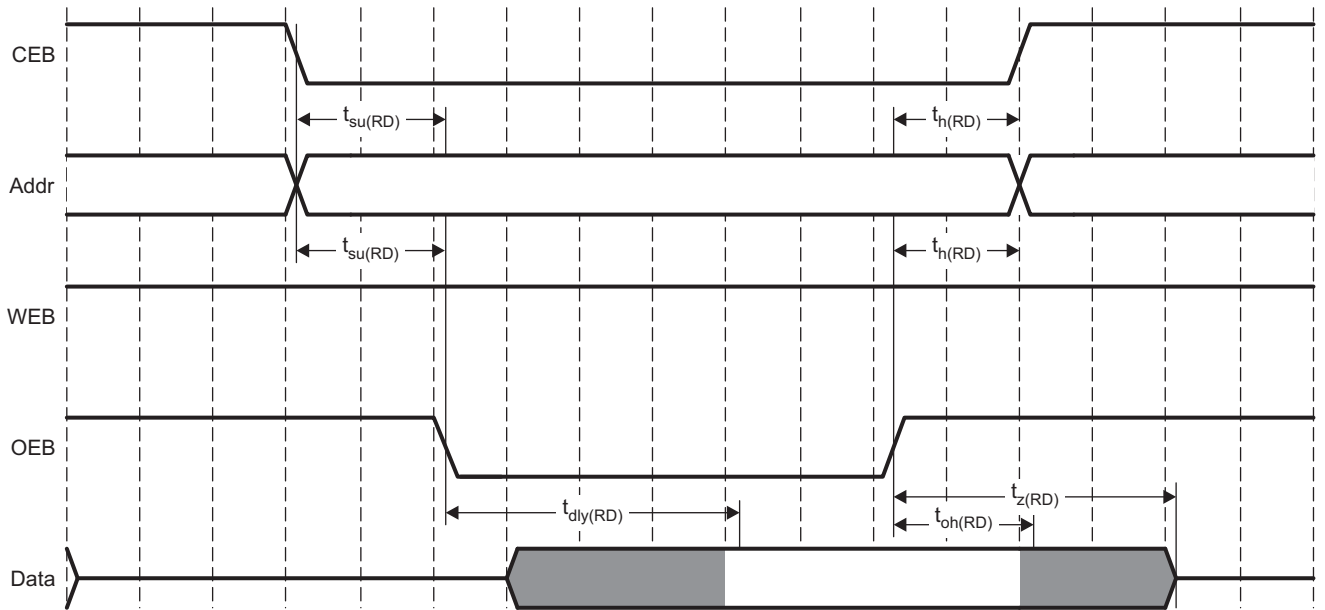

T0517-01

Figure 26. MPU READ Timing Specifications

Table 27. MPU Switching Characteristics (WRITE)

PARAMETER		TEST CONDITIONS	MIN	MAX	UNIT
$t_{su(WR)}$	CEB, DATA, and ADDR setup time to \downarrow WEB	See ⁽¹⁾	1.4		ns
$t_{h(WR)}$	CEB, DATA, and ADDR hold time after \uparrow WEB	See ⁽¹⁾	3		ns
$t_{low(WR)}$	Time WEB and CEB must remain simultaneously LOW	See ⁽¹⁾	4		ns
$t_{high(WR)}$	Time CEB or WRB must remain HIGH between WRITES	See ⁽¹⁾	7		ns
$t_{cycle(WR)}$	Time between WRITES	See ⁽¹⁾	11		ns

- (1) Chip specifications are production tested at 90°C case temperature for the given specification. Early production lots are sample tested at -40°C.

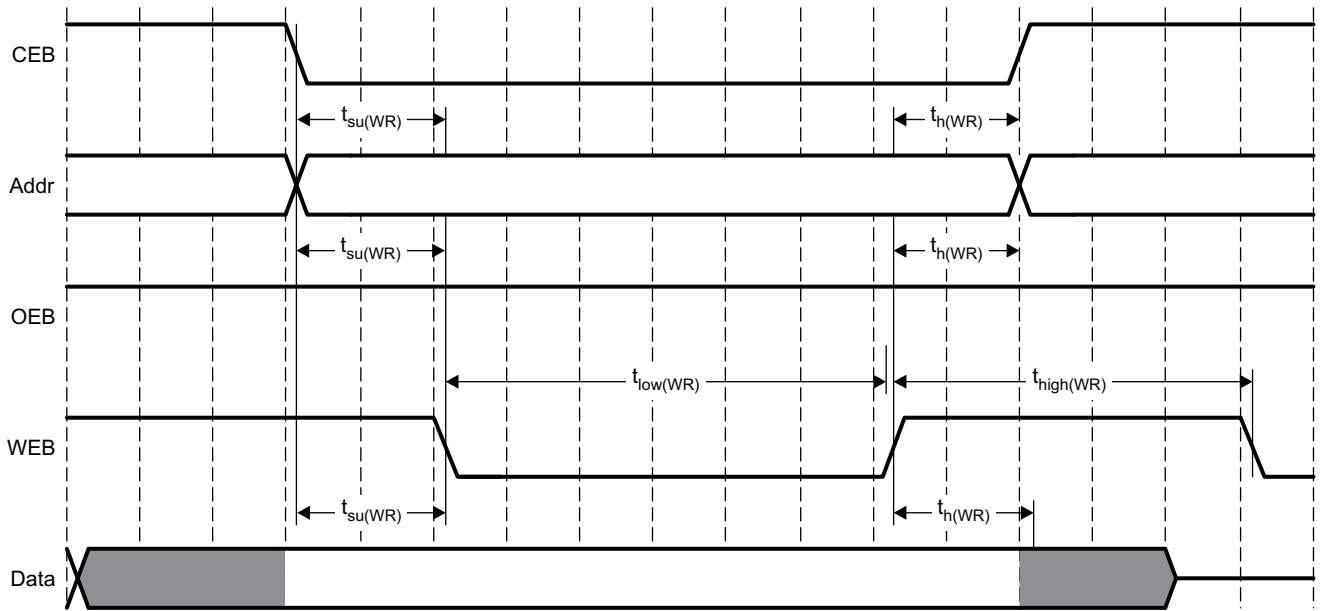

T0518-01

Figure 27. MPU WRITE Timing Specifications

Power Sequencing Guideline

TI ASIC I/O design allows either the core supply (VDD) or the I/O supply (VDDS) to be powered up⁽²⁾ for an indefinite period of time while the other power supply is not powered up, if all of these constraints are met:

- Chip is within all maximum ratings and recommended operating conditions.
- Have followed all warnings about exposure to maximum rated and recommended conditions, particularly junction temperature. These apply to power transitions as well as normal operation.
- Bus contention while VDDS is powered up must be limited to 100 hours over the projected lifetime of the device.
- Bus contention while VDDS is powered down may violate the absolute maximum ratings.

However, it is generally good practice to power up VDD, VDDSHV, and VDDS all within 1 second of each other.

Application Information

The GC533x reference design includes the following additional transmit/receive signal chain components:

- TMS320C6748 digital signal processor (DSP) and DPD adaptation software
- DAC3283 16-bit 800-MSPS, dac348X, or DAC5682 16-bit, 1-GSPS DAC (transmit path)
- CDCE72010 clock generator
- TRF3720 300-MHz to 4.8-GHz quadrature modulator with integrated wideband PLL/VCO
- TRF370317 0.4-GHz to 4-GHz quadrature modulator
- ADS41B49 14-bit, 250-MSPS ADC (and other options; feedback path)
- AMC7823 analog monitoring and control circuit with GPIO and SPI
- PGA870 wideband programmable gain amplifier
- ADS42b49 14-bit dual 250-MSPS receive or complex feedback ADC (and other options; RX path)

MPU Interface Guidelines

The following section describes the hardware interface between the recommended microprocessor and the GC533x. The GC533x interface is an EMIF asynchronous interface.

(2) A supply bus is powered up when the voltage is within the recommended operating range. It is powered down when it is below that range, either stable or in transition.

The *TMS320C674x/OMAP-L1x Processor Peripherals Overview* reference guide ([SPRUFK9](#)) illustrates the connections to the TMS320C6748 peripherals. The *TMS320C674x/OMAP-L1x Processor External Memory Interface A (EMIFA)* user's guide ([SPRUFL6](#)) illustrates the connections to the EMIF A interface, and DSP timing.

It is recommended that if more than one EMIF-A load is connected to the DSP, buffering is used for the control bus WE, RD, address bus, and data bus.

Related Material and Documents

The following documents are available through your TI Field Application Engineer FAE:

- GC5330 EVM schematic diagram
- GC5330 EVM layout diagram
- GC533x Baseband Application Note
- GC533x Baseband beAGC Application Note
- GC533x DDUC Application Note
- GC533x CFR Application Note
- GC533x DPD Application Note
- GC533x TX (BUC, DAC Interface) Application Note
- GC533x RX Application Note
- GC533x feAGC Application Note
- GC533x Sync, MPU Application Note
- GC533x Software Application Guide

APPENDIX

Glossary of Terms

3G	Third generation (refers to next-generation wideband cellular systems that use CDMA)
3GPP	Third Generation Partnership Project (W-CDMA specification, www.3gpp.org)
3GPP2	Third Generation Partnership Project 2 (cdma2000 specification, www.3gpp2.org)
ACLR	Adjacent-channel leakage ratio (measure of out-of-band energy from one CDMA carrier)
ACPR	Adjacent-channel power ratio
ADC	Analog-to-digital converter
BBclk	Clock-to-baseband section of GC533x
BW	Bandwidth
CCDF	Complementary cumulative distribution function
CDMA	Code division multiple access (spread spectrum)
CEVM	Composite error vector magnitude
CFR	Crest factor reduction
DPD_CLK	Clock-to-DPD section of GC533x
CIC	Cascaded integrator comb (type of digital filter)
CMOS	Complementary metal-oxide semiconductor
DAC	Digital-to-analog converter
dB	Decibels
dBm	Decibels relative to 1 mW (30 dBm = 1 W)
DDR	Dual data rate (ADC output format)
DPD	Digital pre-distortion
DSP	Digital signal processing or digital signal processor
DUC	Digital upconverter (usually provides the GC533x input)
EVM	Error vector magnitude
FIR	Finite impulse response (type of digital filter)
HP-DPD	High-performance DPD mode of the GC533x
HS-DPD	High-speed DPD mode of the GC533x
I/Q	In-phase and quadrature (signal representation)
IF	Intermediate frequency
IIR	Infinite impulse response (type of digital filter)
JTAG	Joint Test Action Group (chip debug and test standard 1149.1)
LO	Local oscillator
LSB	Least-significant bit
MSB	Most-significant bit
MSPS	Megasamples per second (1×10^6 samples/s)
PA	Power amplifier
PAR	Peak-to-average ratio
PCDE	Peak code domain error
PDC	Peak detection and cancellation (stage)
PDF	Probability density function
RF	Radio frequency
RMS	Root-mean-square (method to quantify error)
SDR	Single data rate (ADC output format)
SEM	Spectrum emission mask
SNR	Signal-to-noise ratio (usually measured in dB or dBm)
UMTS	Universal mobile telephone service
W-CDMA	Wideband code division multiple access (synonymous with 3GPP)

WiBro Wireless Broadband (Korean initiative IEEE 802.16e)
WiMAX Worldwide Interoperability of Microwave Access (IEEE 802.16e)

REVISION HISTORY

Changes from Revision A (December 2010) to Revision B	Page
• Revised GC533x block diagram	7
• Added text in next-to-last paragraph of Input and Output Syncs section	28
• Combined GC5330 and {GC5337} values into a single row in Table 22	39
• Revised Figure 22	40
• Revised Figure 25	41

PACKAGING INFORMATION

Orderable Device	Status (1)	Package Type	Package Drawing	Pins	Package Qty	Eco Plan (2)	Lead/Ball Finish (6)	MSL Peak Temp (3)	Op Temp (°C)	Device Marking (4/5)	Samples
GC5330IZEV	LIFEBUY	BGA	ZEV	484	60	Green (RoHS & no Sb/Br)	SNAGCU	Level-3-260C-168 HR	-40 to 85	GC5330IZEV DIGITAL TRX	
GC5337IZEV	LIFEBUY	BGA	ZEV	484	60	Green (RoHS & no Sb/Br)	SNAGCU	Level-3-260C-168 HR	-40 to 85	GC5337IZEV DIGITAL TRX	

(1) The marketing status values are defined as follows:

ACTIVE: Product device recommended for new designs.

LIFEBUY: TI has announced that the device will be discontinued, and a lifetime-buy period is in effect.

NRND: Not recommended for new designs. Device is in production to support existing customers, but TI does not recommend using this part in a new design.

PREVIEW: Device has been announced but is not in production. Samples may or may not be available.

OBSOLETE: TI has discontinued the production of the device.

(2) **RoHS:** TI defines "RoHS" to mean semiconductor products that are compliant with the current EU RoHS requirements for all 10 RoHS substances, including the requirement that RoHS substance do not exceed 0.1% by weight in homogeneous materials. Where designed to be soldered at high temperatures, "RoHS" products are suitable for use in specified lead-free processes. TI may reference these types of products as "Pb-Free".

RoHS Exempt: TI defines "RoHS Exempt" to mean products that contain lead but are compliant with EU RoHS pursuant to a specific EU RoHS exemption.

Green: TI defines "Green" to mean the content of Chlorine (Cl) and Bromine (Br) based flame retardants meet JS709B low halogen requirements of <=1000ppm threshold. Antimony trioxide based flame retardants must also meet the <=1000ppm threshold requirement.

(3) MSL, Peak Temp. - The Moisture Sensitivity Level rating according to the JEDEC industry standard classifications, and peak solder temperature.

(4) There may be additional marking, which relates to the logo, the lot trace code information, or the environmental category on the device.

(5) Multiple Device Markings will be inside parentheses. Only one Device Marking contained in parentheses and separated by a "~" will appear on a device. If a line is indented then it is a continuation of the previous line and the two combined represent the entire Device Marking for that device.

(6) Lead/Ball Finish - Orderable Devices may have multiple material finish options. Finish options are separated by a vertical ruled line. Lead/Ball Finish values may wrap to two lines if the finish value exceeds the maximum column width.

Important Information and Disclaimer:The information provided on this page represents TI's knowledge and belief as of the date that it is provided. TI bases its knowledge and belief on information provided by third parties, and makes no representation or warranty as to the accuracy of such information. Efforts are underway to better integrate information from third parties. TI has taken and continues to take reasonable steps to provide representative and accurate information but may not have conducted destructive testing or chemical analysis on incoming materials and chemicals. TI and TI suppliers consider certain information to be proprietary, and thus CAS numbers and other limited information may not be available for release.

In no event shall TI's liability arising out of such information exceed the total purchase price of the TI part(s) at issue in this document sold by TI to Customer on an annual basis.

ZEV (S-PBGA-N484)

PLASTIC BALL GRID ARRAY

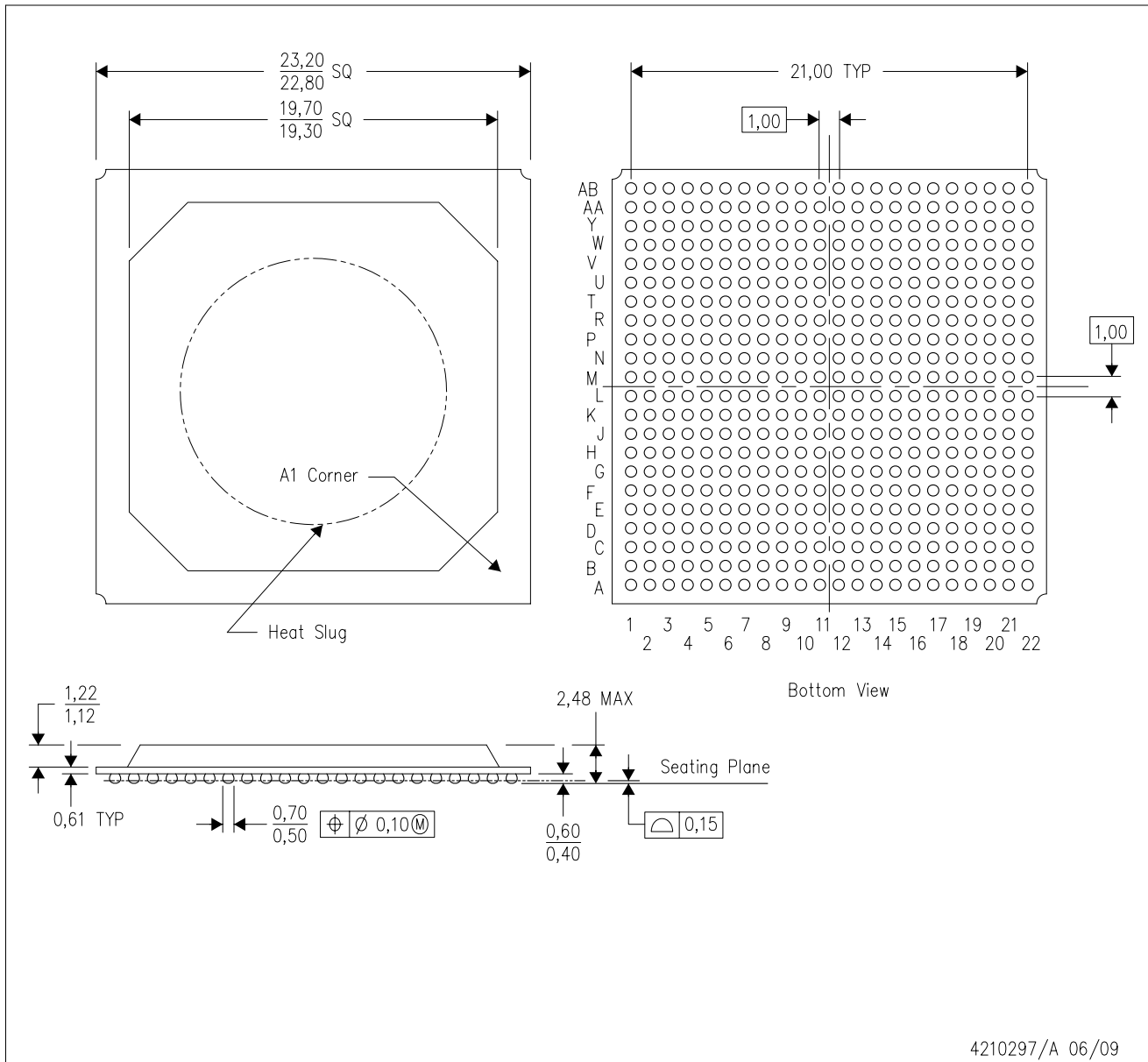

- NOTES:
- A. All linear dimensions are in millimeters. Dimensioning and tolerancing per ASME Y14.5M-1994.
 - B. This drawing is subject to change without notice.
 - C. Falls within JEDEC MO-151
 - D. Thermally enhanced molded plastic package with heat slug (HSL) and embedded thermal spacer.
 - E. This package is Pb-free.

IMPORTANT NOTICE AND DISCLAIMER

TI PROVIDES TECHNICAL AND RELIABILITY DATA (INCLUDING DATASHEETS), DESIGN RESOURCES (INCLUDING REFERENCE DESIGNS), APPLICATION OR OTHER DESIGN ADVICE, WEB TOOLS, SAFETY INFORMATION, AND OTHER RESOURCES "AS IS" AND WITH ALL FAULTS, AND DISCLAIMS ALL WARRANTIES, EXPRESS AND IMPLIED, INCLUDING WITHOUT LIMITATION ANY IMPLIED WARRANTIES OF MERCHANTABILITY, FITNESS FOR A PARTICULAR PURPOSE OR NON-INFRINGEMENT OF THIRD PARTY INTELLECTUAL PROPERTY RIGHTS.

These resources are intended for skilled developers designing with TI products. You are solely responsible for (1) selecting the appropriate TI products for your application, (2) designing, validating and testing your application, and (3) ensuring your application meets applicable standards, and any other safety, security, or other requirements. These resources are subject to change without notice. TI grants you permission to use these resources only for development of an application that uses the TI products described in the resource. Other reproduction and display of these resources is prohibited. No license is granted to any other TI intellectual property right or to any third party intellectual property right. TI disclaims responsibility for, and you will fully indemnify TI and its representatives against, any claims, damages, costs, losses, and liabilities arising out of your use of these resources.

TI's products are provided subject to TI's Terms of Sale (www.ti.com/legal/termsofsale.html) or other applicable terms available either on ti.com or provided in conjunction with such TI products. TI's provision of these resources does not expand or otherwise alter TI's applicable warranties or warranty disclaimers for TI products.

Mailing Address: Texas Instruments, Post Office Box 655303, Dallas, Texas 75265
Copyright © 2019, Texas Instruments Incorporated

Looking for pricing, stock, or lifecycle information?

Click below to explore more details on WIN SOURCE:

⊖ [View GC5337IZEV](#) on WIN SOURCE

⊖ [Texas Instruments](#) Information

Optimize Your Supply Chain with WIN SOURCE Solutions

- ✓ Global Sourcing Solution
- ✓ Obsolete Management
- ✓ Cost Control Management
- ✓ Shortage Management
- ✓ Alternative Solution
- ✓ Excess Inventory Management