

DLPA2000 Power Management and LED/Lamp Driver IC

1 Features

- High Efficiency RGB LED/Lamp Driver with Buck-Boost DC-to-DC Converter, DMD Supplies, DPP Core Supply, 1.8-V Load Switch, and Measurement System in a Small Chip-Scale Package
- Three Low-Impedance (30 mΩ Typical at 27°C) MOSFET Switches for Channel Selection
- Independent, 10-Bit Current Control per Channel
- 750-mA Max LED Current for DLPA2000 Embedded Applications
- On-Chip Motor Driver
- DMD Regulators
 - Requires Only a Single Inductor
 - VOFS: 10 V
 - VBIAS: 18 V
 - VRST: -14 V
 - Passive Discharge to GND When Disabled
- DPP 1.1-V Core Supply
 - Synchronous Step-Down Converter with Integrated Switching FETs
 - Supports up to 600-mA Output Current
- VLED Buck Boost Converter
 - Power Save Mode at Light Load Current
- Low-Impedance Load Switch
 - V_{IN} Range from 1.8 V to 3.6 V
 - Supports up to 200 mA of Current
 - Passive Discharge to GND When Disabled
- DMD Reset Signal Generation and Power Supply Sequencing
- 33-MHz Serial Peripheral Interface (SPI)
- Multiplexer for Measuring Analog Signals

- Battery Voltage
- LED Voltage, LED Current
- Light Sensor (for White Point Correction)
- Internal Reference Voltage
- External (Thermistor) Temperature Sensor
- Monitoring and Protection Circuits
 - Hot Die Warning and Thermal
 - Low-Battery Warning
 - Programmable Battery Undervoltage Lockout (UVLO)
 - Load Switch UVLO
 - Overcurrent and Undervoltage Protection
- DLPA2000 DSBGA Package
 - 56-Ball 0.4-mm Pitch
 - Die Size: 3.280 mm × 3.484 mm ± 0.03 mm

2 Applications

- DLP™ Display Projector
- DLP™ Mobile Sensing

3 Description

The DLPA2000 is a dedicated PMIC/RGB LED/lamp driver for the DLP2010 and DLP2010NIR digital micromirror devices (DMD) when used with a DLPC3430, DLPC3435, or DLPC150 digital controller. For reliable operation of these chipsets, it is mandatory to use the DLPA2000.

Device Information⁽¹⁾

PART NUMBER	PACKAGE	BODY SIZE (NOM)
DLPA2000	DSBGA (56)	3.28 mm × 3.48 mm ± 0.03 mm

(1) For all available packages, see the orderable addendum at the end of the data sheet.

Figure 1. Simplified Schematic

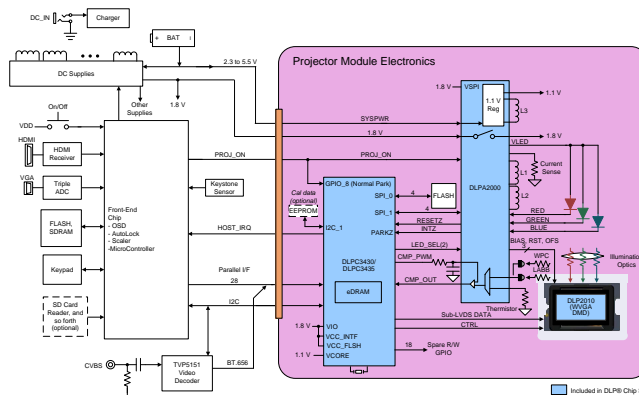

An IMPORTANT NOTICE at the end of this data sheet addresses availability, warranty, changes, use in safety-critical applications, intellectual property matters and other important disclaimers. PRODUCTION DATA.

Table of Contents

1 Features	1	7.4 Device Functional Modes	27
2 Applications	1	7.5 Register Maps	29
3 Description	1	8 Application and Implementation	41
4 Revision History	2	8.1 Application Information	41
5 Pin Configuration and Functions	3	8.2 Typical Projector Application	41
6 Specifications	5	8.3 Typical Mobile Sensing Application	43
6.1 Absolute Maximum Ratings	5	9 Power Supply Recommendations	46
6.2 Storage Conditions	5	10 Layout	47
6.3 ESD Ratings	5	10.1 Layout Guidelines	47
6.4 Recommended Operating Conditions	5	10.2 Layout Example	48
6.5 Thermal Information	6	11 Device and Documentation Support	49
6.6 Electrical Characteristics	6	11.1 Device Support	49
6.7 Motor Driver Timing Requirements	11	11.2 Related Links	49
6.8 Data Transmission Timing Requirements	12	11.3 Community Resources	49
6.9 Typical Characteristics	13	11.4 Trademarks	49
7 Detailed Description	14	11.5 Electrostatic Discharge Caution	50
7.1 Overview	14	11.6 Glossary	50
7.2 Functional Block Diagram	15	12 Mechanical, Packaging, and Orderable Information	51
7.3 Feature Description	16		

4 Revision History

Changes from Revision A (August 2015) to Revision B	Page
• Fixed body size dimension typo in Device Information, corrected 3.48 mm ² to 3.48 mm	1
• Added missing history tags to Revision A that were not listed	1
• Corrected package family to 'DSBGA' in Pin Functions Diagram, originally labeled as 'DSGBA'	3
• Added mechanical package designator YFF to Thermal Information	6
• Changed layout example to show correct image in Figure 46	48

Changes from Original (June 2014) to Revision A	Page
• Changed max current to 750 mA	1
• Added Mobile Sensing application	1
• Added typical Mobile sensing application	43
• Updated the <i>Power Supply Recommendations</i> to remove information that did not apply to the DLPA2000	46

5 Pin Configuration and Functions

**YFF PACKAGE
56-PIN DSBGA
BOTTOM VIEW**

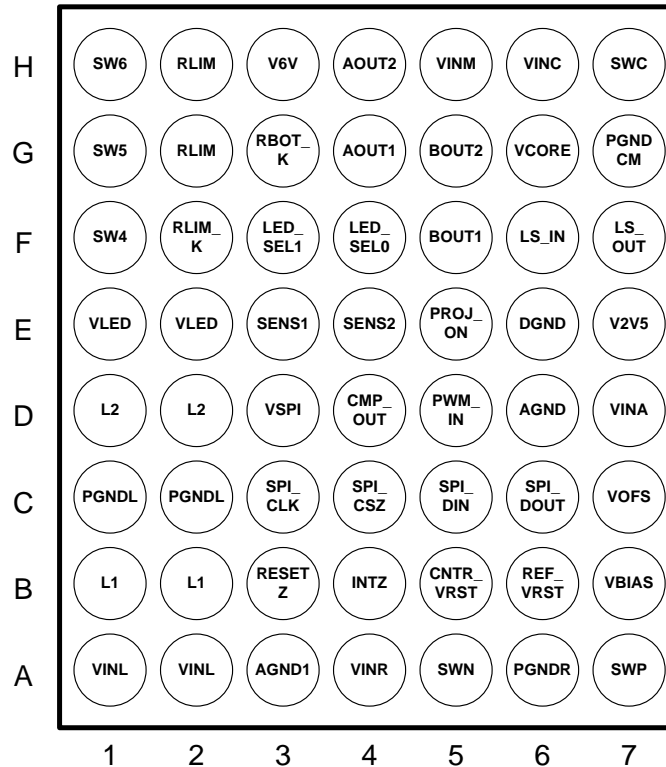

Pin Functions

PIN		I/O	DESCRIPTION
NAME	NUMBER		
VINL	A1	I	Power supply input for VLED BUCK-BOOST power stage. Connect to system power.
	A2		
AGND1	A3	GND	Analog ground. Connect to ground plane.
VINR	A4	I	Power supply input for DMD switch mode power supply (SMPS). Connect to system power.
SWN	A5	I	Connection for the DMD SMPS-inductor (high-side switch).
PGNDR	A6	GND	Power ground for DMD SMPS. Connect to ground plane.
SWP	A7	O	Connection for the DMD SMPS-inductor (low-side switch).
L1	B1	O	Connection for VLED BUCK-BOOST inductor.
	B2		
RESETZ	B3	O	Reset output to the DLP system (active low). Pin is held low to reset DLP system.
INTZ	B4	O	Interrupt output signal (open drain). Connect to pull-up resistor or short to ground.
CNTR_VRST	B5	O	Connection to V_{RST} for fast discharge function.
REF_VRST	B6	I	Reference pin for the V_{RST} regulator. Connect to V_{RST} rail through 100-k Ω resistor.
VBIAS	B7	O	V_{BIAS} output rail. Connect to ceramic capacitor.
PGNDL	C1	GND	Power ground for VLED BUCK-BOOST. Connect to ground plane.
	C2		
SPI_CLK	C3	I	Clock input for SPI interface.
SPI_CSZ	C4	I	SPI chip select (active low).
SPI_DIN	C5	I	SPI data input.

Pin Functions (continued)

PIN		I/O	DESCRIPTION
NAME	NUMBER		
SPI_DOUT	C6	O	SPI data output.
VOFS	C7	O	V _{OFS} output rail. Connect to ceramic capacitor.
L2	D1	I	Connection for VLED BUCK-BOOST inductor.
	D2		
VSPI	D3	I	Power supply input for SPI interface. Connect to system I/O voltage.
CMP_OUT	D4	O	Analog-comparator output.
PWM_IN	D5	I	Reference voltage input for analog comparator.
AGND	D6	GND	Analog ground. Connect to ground plane.
VINA	D7	POWER	Power supply input for sensitive analog circuitry.
VLED	E1	O	VLED BUCK-BOOST converter output pin.
	E2		
SENS1	E3	I	Input signal from light sensor.
SENS2	E4	I	Input signal from temperature sensor.
PROJ_ON	E5	I	Input signal to enable or disable the IC and DLP projector.
DGND	E6	GND	Digital ground. Connect to ground plane.
V2V5	E7	O	Internal supply filter pin for digital logic; typical 2.5 V.
SW4	F1	O	Low-side MOSFET switch for LED cathode. Connect to RGB LED assembly.
RLIM_K	F2	I	Kelvin sense connection to top side of LED current sense resistor. For best accuracy, route this trace directly to the top of the current sense resistor and separate it from the normal trace from the current sense resistor to the RLIM pins.
LED_SEL1	F3	I	Digital input to the RGB STROBE DECODER.
LED_SEL0	F4	I	Digital input to the RGB STROBE DECODER.
BOUT1	F5	O	Motor driver B phase output1.
LS_IN	F6	I	Load switch.
LS_OUT	F7	O	Load switch.
SW5	G1	O	Low-side MOSFET switch for LED cathode. Connect to RGB LED assembly.
RLIM	G2	O	Connection to LED 'current sense' resistor. Bottom side of sense resistor is connected to GND.
RBOT_K	G3	I	Kelvin sense connection to ground side of LED current sense resistor.
AOUT1	G4	O	Motor driver A phase output1.
BOUT2	G5	O	Motor driver B phase output2.
VCORE	G6	I	VCORE BUCK converter feedback pin.
PGNDCM	G7	GND	Power ground for VCORE BUCK and motor driver.
SW6	H1	O	Low-side MOSFET switch for LED cathode. Connect to RGB LED assembly.
RLIM	H2	O	Connection to LED current sense resistor. Bottom side of sense resistor is connected to GND.
V6V	H3	O	Internal supply filter pin for gate driver circuitry. Typical 6.25 V.
AOUT2	H4	O	Motor driver A phase output2.
VINM	H5	I	Power supply input for motor driver power stage. Connect to system power.
VINC	H6	I	Power supply input for VCORE BUCK power stage. Connect to system power.
SWC	H7	I/O	Connection for 1.1-V BUCK inductor.

6 Specifications

6.1 Absolute Maximum Ratings

over operating free-air temperature (unless otherwise noted) ⁽¹⁾

	MIN	MAX	UNIT
Input voltage at V_{INL} , V_{INA} , V_{INR} , V_{INC} , V_{INM}	-0.3	7	V
Ground pins to system ground	-0.3	0.3	V
Voltage at SWN	-18.0	7	V
Voltage at SWP, V_{BIAS}	-0.3	20	V
Voltage at V_{OFS}	-0.3	12	V
Voltage at V_{6V} , V_{LED} , L1, L2, SWC, SW4, SW5, SW6, INTZ, PROJ_ON	-0.3	7	V
Voltage at all pins, unless noted otherwise	-0.3	3.6	V
Source current RESETZ, CMP_OUT		1	mA
Source current SPI_DOUT		5.5	mA
Sink current RESETZ, CMP_OUT		1	mA
Sink current SPI_DOUT, INTZ		5.5	mA
Peak output current	Internally limited		
Continuous total power dissipation	Internally limited by thermal shutdown		
T_J Operating junction temperature	-30	150	°C

(1) Stresses beyond those listed under *Absolute Maximum Ratings* may cause permanent damage to the device. These are stress ratings only, which do not imply functional operation of the device at these or any other conditions beyond those indicated under *Recommended Operating Conditions*. Exposure to absolute-maximum-rated conditions for extended periods may affect device reliability.

6.2 Storage Conditions

applicable before the DMD is installed in the final product.

	MIN	MAX	UNIT
ENVIRONMENTAL			
T_{stg} DMD Storage Temperature	-65	150	°C

6.3 ESD Ratings

	VALUE	UNIT
$V_{(ESD)}$ Electrostatic discharge	Human body model (HBM), per ANSI/ESDA/JEDEC JS-001, all pins ⁽¹⁾	±2000
	Charged device model (CDM), per JEDEC specification JESD22-C101, all pins ⁽²⁾	±500

(1) JEDEC document JEP155 states that 500-V HBM allows safe manufacturing with a standard ESD control process.

(2) JEDEC document JEP157 states that 250-V CDM allows safe manufacturing with a standard ESD control process.

6.4 Recommended Operating Conditions

over operating free-air temperature range (unless otherwise noted)

	MIN	NOM	MAX	UNIT
Input voltage range at V_{INL} , V_{INA} , V_{INR} , V_{INC} , V_{INM}	Full functional and parametric performance			V
	Extended operating range, limited parametric performance			
Voltage range at V_{SPI}	1.65	1.8	3.6	V
T_A Operational ambient temperature	-10		85	°C
T_J Operational junction temperature	-10		120	°C

6.5 Thermal Information

THERMAL METRIC ⁽¹⁾		DLPA2000	UNIT
		YFF (DSBGA)	
		56 PINS	
$R_{\theta JA}$	Junction-to-ambient thermal resistance ⁽²⁾	45	°C/W

(1) For more information about traditional and new thermal metrics, see the *IC Package Thermal Metrics* application report, [SPRA953](#).

(2) Estimated when mounted on high K JEDEC board per JESD 51-7 with thickness of 1.6 mm, 4 layers, size of 76.2 mm x 114.3 mm, and 2-oz. copper for top and bottom plane. Actual thermal impedance will depend on PCB used in the application.

6.6 Electrical Characteristics

over operating free-air temperature range (unless otherwise noted) (see ⁽¹⁾⁽²⁾)

PARAMETER		TEST CONDITIONS	MIN	TYP	MAX	UNIT
SUPPLIES						
INPUT VOLTAGE						
V_I	Input voltage range	$V_{INA}, V_{INR}, V_{INL}, V_{INC}$	2.7	3.6	6	V
	Extended input voltage range ⁽¹⁾		2.3	3.6	6	
V_{LOW_BAT}	Low-battery warning threshold	V_{INA} falling		3		V
	Hysteresis	V_{INA} rising		100		mV
$V_{hys(UVLO)}$	Undervoltage lockout threshold	V_{INA} falling (through 5-bit trim function)	2.3		4.5	V
	Hysteresis	V_{INA} rising		100		mV
$V_{STARTUP}$	Startup voltage	$V_{BIAS}, V_{OFS}, V_{RST}$; loaded with 2 mA	2.5			V
INPUT CURRENT						
I_Q	ACTIVE mode	Motor current excluded		15		mA
I_{STD}	STANDBY mode			900		μA
I_{IDLE}	IDLE mode			10		μA
INTERNAL SUPPLIES						
V_{V6V}	Internal supply, analog			6.25		V
C_{LDO_V6V}	Filter capacitor for V6V LDO			100		nF
V_{V2V5}	Internal supply, logic			2.5		V
C_{LDO_V2V5}	Filter capacitor for V2V5 LDO			2.2		μF
DMD REGULATOR						
$R_{DS(ON)}$	MOSFET ON-resistance	Switch E (from V_{INR} to SWN)		1000		mΩ
		Switch F (from SWP to PGNDR)		320		
V_{FW}	Forward voltage drop	Switch G ⁽²⁾ (from SWP to V_{BIAS}) $V_{INR} = 5\text{ V}, V_{SWP} = 2\text{ V}, I_F = 100\text{ mA}$		1.3		V
		Switch H (from SWP to V_{OFS}) $V_{INR} = 5\text{ V}, V_{SWP} = 2\text{ V}, I_F = 100\text{ mA}$		1.3		
t_{DIS}	Rail discharge time	$V_{IN} = 2.9\text{ V}; C_{OUT} = 110\text{ nF}$			40	μs
t_{PG}	Power-good timeout	Not tested in production		6		ms
I_{LIMIT}	Switch current limit			312		mA
L	Inductor value			10		μH
V_{OFS} REGULATOR						
V_{OFS}	Output voltage			10		V
	DC output voltage accuracy	$I_{OUT} = 2\text{ mA}$	-2%		2%	
	DC load regulation	$V_{IN} = 3.6\text{ V}, I_{OUT} = 0\text{ to }2\text{ mA}$		-19		V/A
	DC line regulation	$V_{INA}, V_{INL}, V_{INR}, V_{INC} 2.7\text{ to }6.0\text{ V}, I_{OUT} = 2\text{ mA}$		35		mV/V
V_{RIPPLE}	Output ripple	$V_{IN} = 3.6\text{ V}, I_{OUT} = 2\text{ mA}, C_{OUT} = 440\text{ nF}^{(3)}$		375		mVpp
I_{OUT}	Output current		0		3	mA

(1) Fully functional but limited parametric performance

(2) Including rectifying diode

(3) To reduce ripple the C_{OUT} can be increased. V_{RIPPLE} is inversely proportional to C_{OUT} .

Electrical Characteristics (continued)

over operating free-air temperature range (unless otherwise noted) (see ⁽¹⁾⁽²⁾)

PARAMETER		TEST CONDITIONS	MIN	TYP	MAX	UNIT
PG	Power-good threshold (fraction of nominal output voltage)	V _{OFS} rising		86%		
		V _{OFS} falling		66%		
R _{DIS}	Output discharge resistor	Active when rail is disabled		100		Ω
C _{OUT}	Output capacitor	Recommended value (output capacitors for V _{OFS} /V _{BIAS} must be equal)	110	220		nF
		t _{DISCHARGE} < 40 μs at 2.9 V	100		110	nF

Electrical Characteristics (continued)

 over operating free-air temperature range (unless otherwise noted) (see ⁽¹⁾⁽²⁾)

PARAMETER		TEST CONDITIONS	MIN	TYP	MAX	UNIT
V_{BIAS} REGULATOR						
V _{BIAS}	Output voltage			18		V
	DC output voltage accuracy	I _{OUT} = 2 mA	-2%		2%	
	DC load regulation	V _{IN} = 3.6 V, I _{OUT} = 0 to 2 mA		-14		V/A
	DC line regulation	V _{INA} , V _{INL} , V _{INR} , V _{INC} 2.7 to 6 V, I _{OUT} = 2 mA		18		mV/V
V _{RIPPLE}	Output ripple	V _{IN} = 3.6 V, I _{OUT} = 2 mA, C _{OUT} = 440 nF (see ⁽³⁾)		375		mVpp
I _{OUT}	Output current		0		4	mA
PG	Power-good threshold (fraction of nominal output voltage)	V _{BIAS} rising		86%		
		V _{BIAS} falling		66%		
R _{DIS}	Output discharge resistor	Active when rail is disabled		100		Ω
C _{OUT}	Output capacitor	Recommended value (output capacitors for V _{OFS} / V _{BIAS} must be equal)	110	220		nF
		t _{DISCHARGE} < 40 μs at 2.9 V	100		110	
V_{RST} REGULATOR						
V _{RST}	Output voltage			-14		V
	DC output voltage accuracy	I _{OUT} = 2 mA	-3%		3%	
	DC load regulation	V _{IN} = 3.6 V, I _{OUT} = 0 to 2 mA		13		V/A
	DC line regulation	V _{INA} , V _{INL} , V _{INR} , V _{INC} 2.7 to 6 V, I _{OUT} = 2 mA		-21		mV/V
V _{RIPPLE}	Output ripple	V _{IN} = 3.6 V, I _{OUT} = 2 mA, C _{OUT} = 440 nF (see ⁽³⁾)		375		mVpp
V _{REF_VRST}	Reference voltage			500		mV
I _{OUT}	Output current		0		4	mA
PG	Power-good threshold (fraction of nominal output voltage)	V _{RST} rising		90%		
		V _{RST} falling		90%		
R _{DIS}	Output discharge resistor	Active when rail is disabled		±150		Ω
C _{OUT}	Output capacitor		110	220		nF
		t _{DISCHARGE} < 70 μs at V _{BAT} ≥ 2.7 V	100		110	
LED DRIVER						
VLED BUCK-BOOST						
V _{LED}	Output voltage range		1.2		5.5	V
	Default output voltage	SW4, SW5, SW6 in OPEN position		3.5		
V _{OVP}	Output overvoltage protection	Clamps buck-boost output	5.5		7	V
V _{LED_OVP}	Fault detection threshold	Triggers VLED_OVP interrupt		5.4		V
I _{SW}	Switch current limit		3.5	4.0	4.5	A
R _{DS(ON)}	MOSFET ON-resistance	Switch A (from V _{INL} to L1)		50		mΩ
		Switch B (from L1 to PGNDL)		50		
		Switch C (from L2 to PGNDL)		50		
		Switch D (from L2 to VLED)		50		
f _{SW}	Switching frequency			2.25		MHz
C _{OUT}	Output capacitance			2 × 22		μF
RGB STROBE CONTROLLER SWITCHES						
R _{DS(ON)}	Drain-source ON-resistance	SW4, SW5, SW6		30	75	mΩ
I _{LEAK}	OFF-state leakage current	V _{DS} = 5.0 V			1	μA

Electrical Characteristics (continued)

over operating free-air temperature range (unless otherwise noted) (see ⁽¹⁾⁽²⁾)

PARAMETER		TEST CONDITIONS	MIN	TYP	MAX	UNIT
LED CURRENT CONTROL						
V_f	LED forward voltage				4.8	V
I_{LED}	DLPA2000 LED currents	$V_{IN} \geq 2.3\text{ V}$, $V_{LED} \leq 4.8\text{ V}$ $R_{LIM} = 100\text{ m}\Omega$, 0.1%, $T_A = 25^\circ\text{C}$ (see register settings) Current at minimum code 0x00Ch for SWx IDAC[9:0].		25		mA
		$V_{IN} \geq 2.3\text{ V}$, $V_{LED} \leq 4.8\text{ V}$ $R_{LIM} = 100\text{ m}\Omega$, 0.1%, $T_A = 25^\circ\text{C}$ (see register settings) Current at maximum code 0x307h for SWx_IDAC[9:0].		750		
	DC current accuracy, SW4, 5, 6	$R_{LIM} = 100\text{ m}\Omega$		25		mA
	Transient LED current limit range	$ILIM[3:0] = 0000$ at $R_{LIM} = 100\text{ m}\Omega$		130		mA
$ILIM[3:0] = 1111$ at $R_{LIM} = 100\text{ m}\Omega$			1500			
t_{rise}	Current rise time	I_{LED} from 5% to 95%, $I_{LED} = 300\text{ mA}$, Transient current limit disabled Not tested in production			50	μs
1.1-V REGULATOR						
VCORE (BUCK)						
V_{IN}	Input voltage		2.3		6	V
V_{OUT}	Nominal fixed output voltage			1.1		V
	DC output voltage accuracy	$0\text{ mA} \leq I_{OUT} \leq 600\text{ mA}$ at $V_{IN} > 2.5\text{ V}$ $V_{OUT} = 1.1\text{ V}$	-1.5%		1.5%	
d	Maximum duty cycle				100%	
$R_{DS(ON)}$	Low-side MOSFET on-resistance	$V_{IN} = 3.6\text{ V}$, $T_J = 27^\circ\text{C}$		185	380	$\text{m}\Omega$
	High-side MOSFET on-resistance			240	480	$\text{m}\Omega$
I_{OUT}	Output current	$V_{IN} > 2.3\text{ V}$		300	600	mA
I_{LIMIT}	Switch current limit			1		A
T_{SS}	Soft-start time	Time to ramp from 10% to 90% of V_{OUT} , $V_{IN} = 3.6\text{ V}$		250		μs
C_{OUT}	Output capacitance			10		μF
L	Nominal Inductance			2.2		μH
LOAD SWITCH						
V_{IN}	Input voltage range	LS_IN	1.8		3.6	V
$R_{DS(ON)}$	P-channel MOSFET on-resistance	$V_{IN} = 1.8\text{ V}$, over full temperature range		385	505	$\text{m}\Omega$
C_{OUT}	Output capacitor	Ceramic	4.7	10	12	μF
	ESR of output capacitor	Ceramic	5	20	500	$\text{m}\Omega$
MEASUREMENT SYSTEM (AFE)						
G	Amplifier gain (PGA)	AFE_GAIN[1:0] = 01		1.0		V/V
		AFE_GAIN[1:0] = 10		9.5		
		AFE_GAIN[1:0] = 11		18		
V_{OFS}	Input referred offset voltage	PGA, AFE_CAL_DIS = 1 Not tested in production	-1		1	mV
		Comparator Not tested in production	-1.5		1.5	
t_{settle}	Settling time	To 1% of final value (not tested in production)			15	μs
		To 0.1% of final value (not tested in production)			52	

Electrical Characteristics (continued)

 over operating free-air temperature range (unless otherwise noted) (see ⁽¹⁾⁽²⁾)

PARAMETER		TEST CONDITIONS	MIN	TYP	MAX	UNIT
f_{sample}	Sampling rate	Not tested in production			19	kHz
LOGIC LEVELS AND TIMING CHARACTERISTICS						
V_{OL}	Output low-level	$I_{\text{O}} = 0.5\text{-mA}$ sink current (RESETZ, CMP_OUT)	0		0.3	V
		$I_{\text{O}} = 5\text{-mA}$ sink current (SPI_DOUT, INTZ)	0		$0.3 \times V_{\text{SPI}}$	
V_{OH}	Output high-level	$I_{\text{O}} = 0.5\text{-mA}$ source current (RESETZ, CMP_OUT)	1.3		2.5	V
		$I_{\text{O}} = 5\text{-mA}$ source current (SPI_DOUT)	$0.7 \times V_{\text{SPI}}$		V_{SPI}	
V_{IL}	Input low-level	PROJ_ON, LED_SEL0, LED_SEL1	0		0.4	V
		SPI_CSZ, SPI_CLK, SPI_DIN	0		$0.3 \times V_{\text{SPI}}$	
V_{IH}	Input high-level	PROJ_ON, LED_SEL0, LED_SEL1	1.2			V
		SPI_CSZ, SPI_CLK, SPI_DIN	$0.7 \times V_{\text{SPI}}$		V_{SPI}	
I_{BIAS}	Input bias current	$V_{\text{IO}} = 3.3\text{ V}$, any input pin			0.5	μA
t_{DEGLITCH}	Deglitch time	PROJ_ON, (not tested in production)		1		ms
		LED_SEL0, LED_SEL1 pins (not tested in production)		300		ns
INTERNAL OSCILLATOR						
f_{OSC}	Oscillator frequency			9		MHz
	Frequency accuracy	$T_{\text{A}} = -30$ to 85°C	-10%		10%	
THERMAL SHUTDOWN						
T_{WARN}	Thermal warning (HOT threshold)			120		$^{\circ}\text{C}$
	Hysteresis			10		
T_{SHUTDOWN}	Thermal shutdown (TSD threshold)			150		$^{\circ}\text{C}$
	Hysteresis			15		
MOTOR DRIVER						
POWER SUPPLY						
V_{INM}	Operating motor supply voltage		2		6	V
I_{M}	Operating motor current				500 ⁽⁴⁾	mA
H-BRIDGE FETS						
$R_{\text{DS(ON)}}$	HS + LS FET on resistance	$V_{\text{V2V5}} = 2.5\text{ V}$, $V_{\text{M}} = 3\text{ V}$, $I_{\text{O}} = 200\text{ mA}$, $T_{\text{J}} = 25^{\circ}\text{C}$		1.9	2.1	Ω
I_{OFF}	Off-state leakage current				± 200	nA
MOTOR DRIVER PROTECTION CIRCUITS						
I_{OCP}	Overcurrent protection trip level per A-out or B-out pin		0.53		1.16	A
t_{TSD}	Thermal shutdown temperature	Die temperature	150	160	180	$^{\circ}\text{C}$

(4) Power dissipation and thermal limits must be observed

6.7 Motor Driver Timing Requirements

The table lists the timing numbers to drive the motor voltages correctly, while Figure 2 shows the timing sequences.

NUMBER		MIN	MAX	UNIT
1	t_1 Delay time, xPHASE high to xOUT1 low		300	ns
2	t_2 Delay time, xPHASE high to xOUT2 high		200	ns
3	t_3 Delay time, xPHASE low to xOUT1 high		200	ns
4	t_4 Delay time, xPHASE low to xOUT1 low		300	ns
5	t_5 Delay time, xENBL high to xOUTx high		200	ns
6	t_6 Delay time, xENBL high to xOUTx low		300	ns
7	t_7 Output enable time		300	ns
8	t_8 Output disable time		300	ns
9	t_9 Delay time, xINx high to xOUTx high		160	ns
10	t_{10} Delay time, xINx low to xOUTx low		160	ns
11	t_R Output rise time	30	188	ns
12	t_F Output fall time	30	188	ns

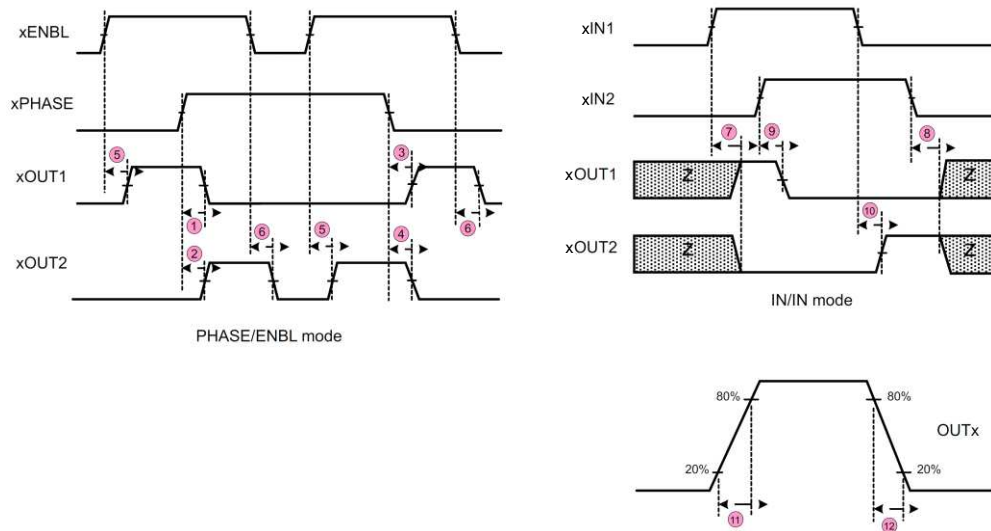

Figure 2. Bridge Control

6.8 Data Transmission Timing Requirements

VBAT = 3.6 ± 5%, T_A = 25 °C, C_L = 10 pF (unless otherwise noted)

		MIN	NOM	MAX	UNIT
f _{CLK}	Serial clock frequency	0		36	MHz
t _{CLKL}	Pulse width low, SPI_CLK, 50% level	10			ns
t _{CLKH}	Pulse width high, SPI_CLK, 50% level	10			ns
t _t	Transition time, 20% to 80% level, all signals	0.2		4	ns
t _{CSCR}	SPI_CSZ falling to SPI_CLK rising, 50% level	8			ns
t _{CFCS}	SPI_CLK falling to SPI_CSZ rising, 50% level			1	ns
t _{CDS}	SPI_DIN data setup time, 50% level	7			ns
t _{CDH}	SPI_DIN data hold time, 50% level	6			ns
t _{IS}	SPI_DOUT data setup time ⁽¹⁾ , 50% level	10			ns
t _{IH}	SPI_DOUT data hold time ⁽¹⁾ , 50% level	0			ns
t _{CFDO}	SPI_CLK falling to SPI_DOUT data valid, 50% level			13	ns
t _{CSZ}	SPI_CSZ rising to SPI_DOUT HiZ			6	ns

(1) The DPPxxxx processors send and receive data on the falling edge of the clock.

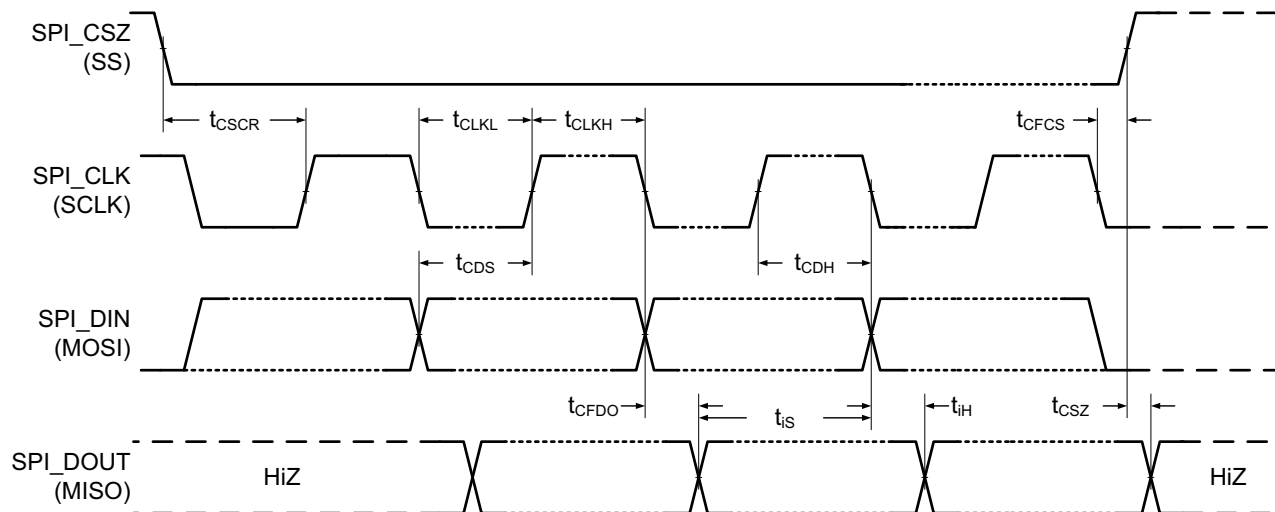
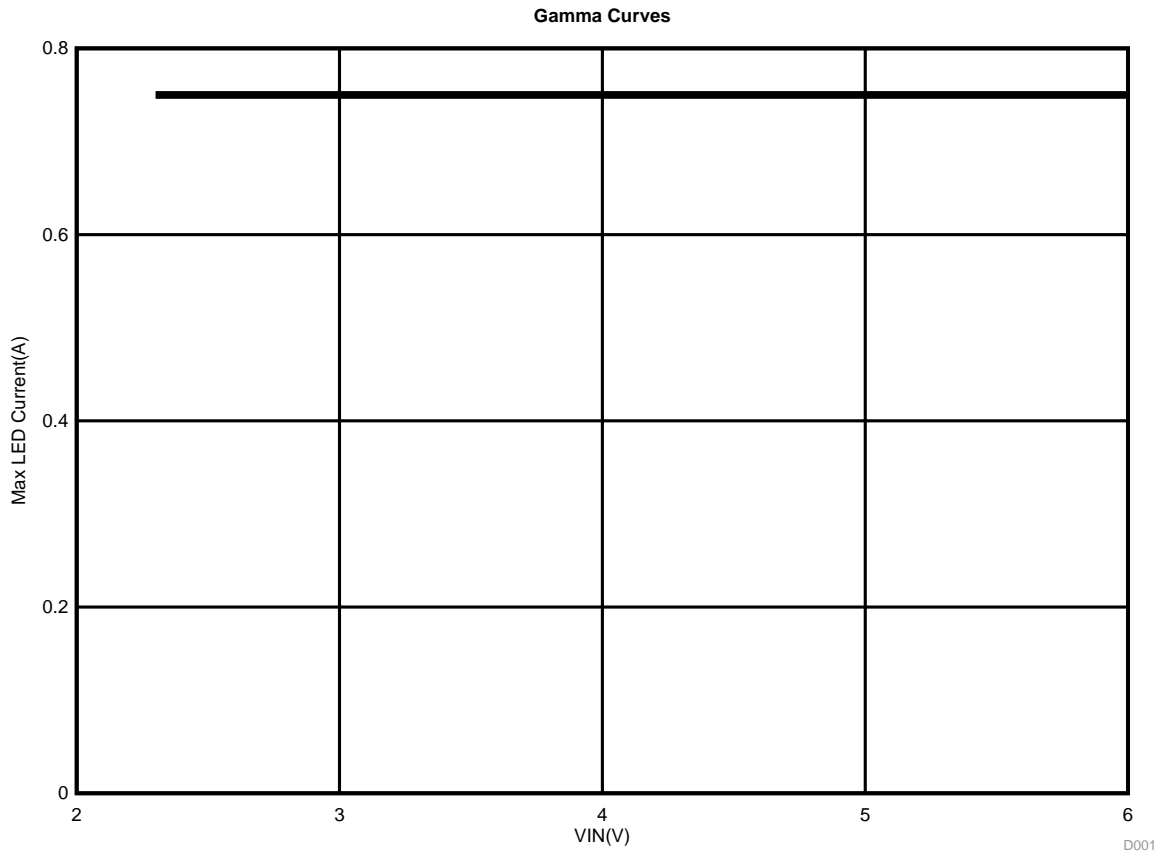

Figure 3. SPI Timing Diagram

6.9 Typical Characteristics

The maximum output current of the buck-boost is a function of input voltage (V_{IN}) and output voltage (V_{LED}). The relationship between V_{IN} , V_{LED} , and $MAX I_{LED}$ is shown in Figure 4. Note that V_{LED} is the output of the buck-boost regulator, which includes the voltage drop across the sense resistor R_{LIM} (100 m Ω typical), internal strobe control switch (75 m Ω max), and the forward voltage of the LED.



$$2.3 \text{ V} < V_{LED} < 4.8 \text{ V}$$

Figure 4. Maximum LED Output Current as a Function of Input Voltage (V_{IN}) and Buck-Boost Output Voltage (V_{LED})

7 Detailed Description

7.1 Overview

The DLPA2000 is a power management and LED driver IC optimized for DLP video and data display systems and meant for use in either embedded or accessory projector applications. DLPA2000 is part of the chipset comprising of either DLP2010 (0.2 WVGA) DMD and DLPC3430/DLPC3435 controller or the DLP2010NIR (0.2 WVGA NIR) DMD and DLPC150 controller. The DLPA2000 contains a complete LED driver including high efficiency power convertors. The DLPA2000 can supply up to 750 mA per LED. Integrated high-current switches are included for sequentially selecting R, G, and B LEDs. The DLPA2000 also contains three regulated DC supplies for the DMD reset circuitry: V_{BIAS} , V_{RST} and V_{OFS} , as well as a regulated DC supply of 1.1 V and a load switch for the 1.8 V to support the DLPC3430 or DLPC3435 controller. The DLPA2000 also contains a motor driver which can be used to drive the focus lens motor. The DLPA2000 has a SPI used for setting the configuration. Using SPI, currents can be set independently for each LED with 10-bit resolution. Other features included are the generation of the system reset, power sequencing, input signals for sequentially selecting the active LED, IC self-protections, and an analog MUX for routing analog information to an external ADC.

7.3 Feature Description

7.3.1 DMD Regulators

DLPA2000 contains three switch-mode power supplies that power the DMD. These rails are V_{OFS} , V_{BIAS} , and V_{RST} . After pulling the PROJ_ON pin high, the DMD is first initialized followed by a power-up of the V_{OFS} line after a small delay of less than 10 ms followed by V_{BIAS} and V_{RST} with an additional delay of 145 ms. The LED driver and STROBE DECODER circuit can only be enabled after all three rails are enabled. There are two power-down sequences, the normal power-down timing initiated after pulling the PROJ_ON pin low, and a fast power-down mode where if any one of the rails encounters a fault such as an output short, all three rails are discharged simultaneously. The detailed power-up and power-down diagrams are shown in Figure 5 and Figure 6.

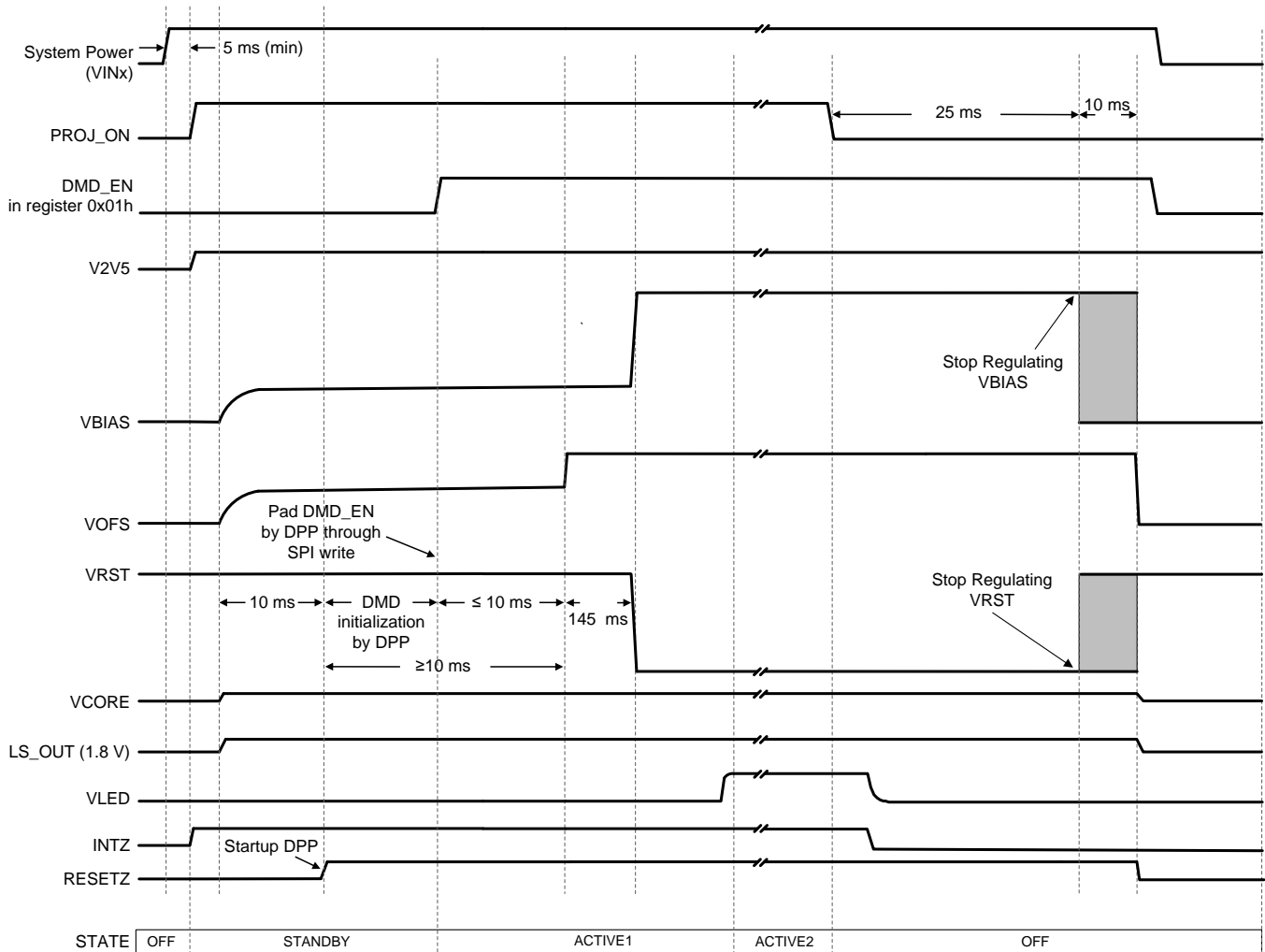
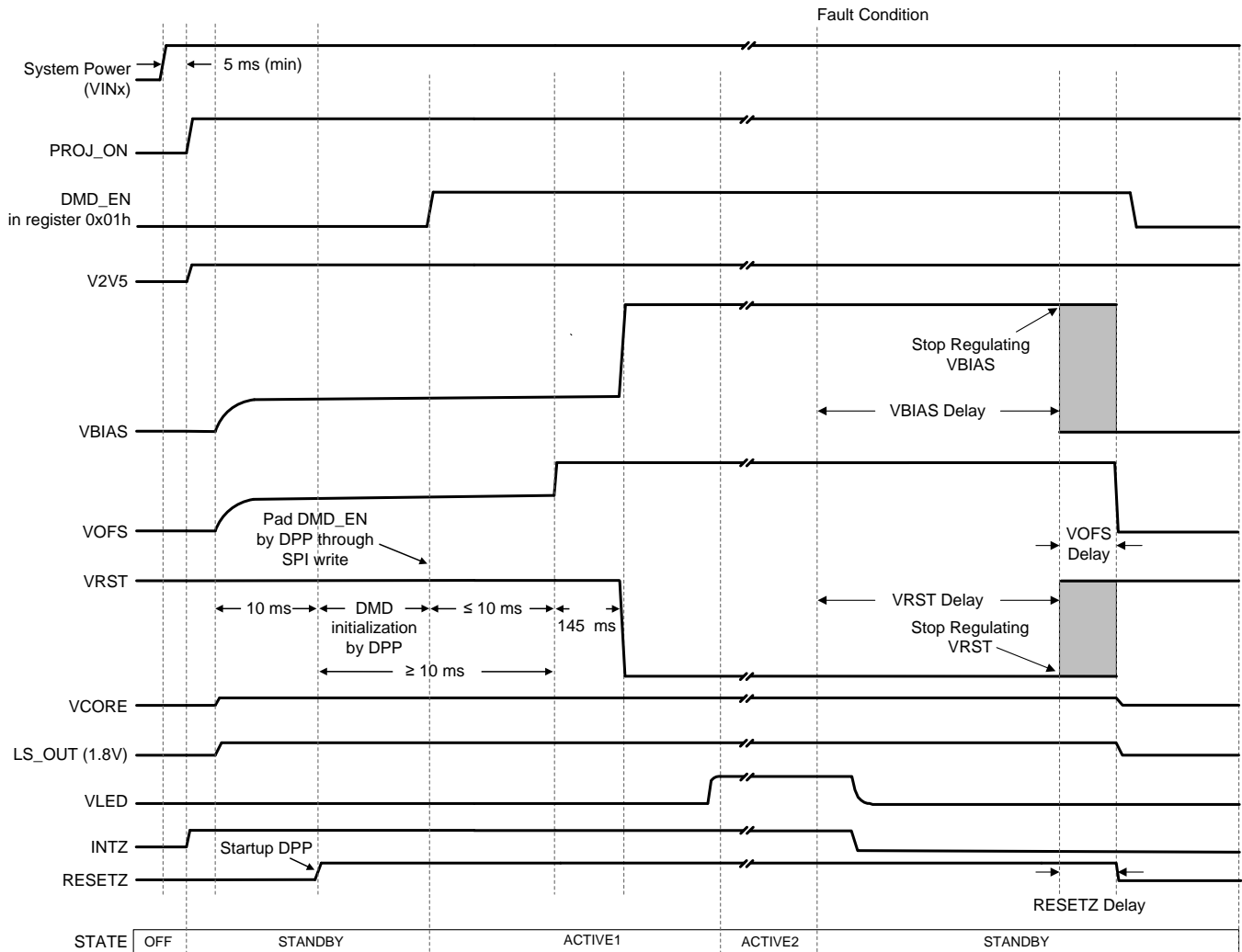

Figure 5. Power Sequence Normal Shutdown Mode

NOTE

All values are typical (unless otherwise noted).

Feature Description (continued)



A. If the FAULT condition happens and its associated interrupt is masked in the interrupt mask register (0Dh), the INTZ does not go low, but all other timing shown in the diagram is unaffected.

Figure 6. Power Sequence Fault Shutdown Mode

NOTE

All values are typical (unless otherwise noted).

7.3.2 RGB Strobe Decoder

DLPA2000 contains RGB color-sequential circuitry that is composed of three NMOS switches, the LED driver, the strobe decoder, and the LED current control. The NMOS switches are connected to the terminals of the external LED package and turn the currents through the LEDs on and off. Package connections are shown in Figure 7 and Figure 10 and the corresponding switch map is in Table 1.

The LED_SEL[1:0] signals typically receive a rotating code switching from RED to GREEN to BLUE and then back to RED. When the LED_SEL[1:0] input signals select a specific color, the NMOSFETs are controlled based on the color selected, and a 10-bit current control DAC for this color is selected that provides a control current to the RGB LEDs' feedback control network.

Feature Description (continued)

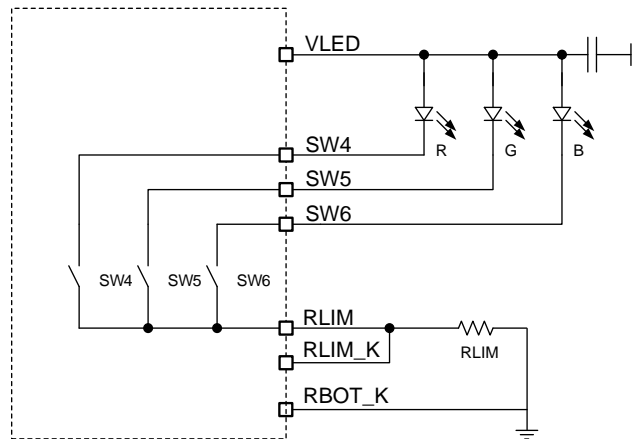

Figure 7. Switch Connection for a Common-Anode LED Assembly

Table 1. Switch Positions for Common Anode RGB LEDs (MAP = 0)

Common Anode				
LED_SEL[1:0]	SW6	SW5	SW4	IDAC INPUT
0x00h	Open	Open	Open	N/A
0x01h	Open	Open	Closed	SW4_IDAC[9:0]
0x02h	Open	Closed	Open	SW5_IDAC[9:0]
0x03h	Closed	Open	Open	SW6_IDAC[9:0]

The switching of the three NMOS switches is controlled such that switches are returned to the open position first before the closed connections are made (break before make). The dead time between opening and closing switches is controlled through the BBM register. Switches that already are in the closed position (and are to remain in the closed state according to the SWCNTRL register) are not opened during the BBM delay time.

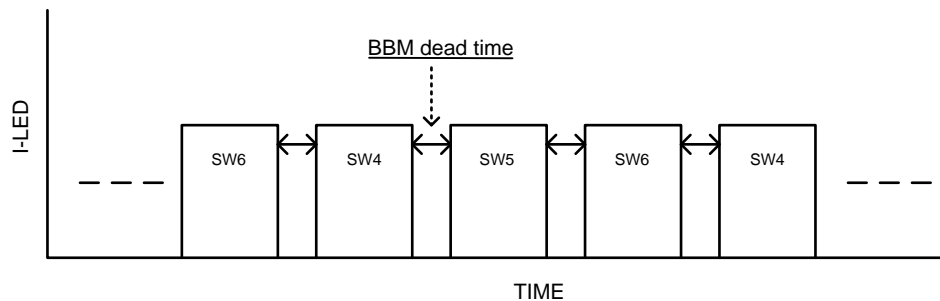

Figure 8. BBM Timing (See Register 0Bh in Figure 27)

7.3.3 LED Current Control

DLPA2000 provides time-sequential circuitry to drive three LEDs with independent current control. A system based on a common anode LED configuration is shown in Figure 10 and consists of a buck-boost converter, which provides the voltage to drive the LEDs, three switches connected to the cathodes of the LEDs, an R_{LIM} resistor used to sense the LED current, and a current DAC to control the LED current. The voltage measured at the pin V(RLIM_K) is used by the regulator loop.

The STROBE DECODER controls the switch positions as described in the previous section (RGB Strobe Decoder). With all switches in the open position, the buck-boost output assumes an output voltage of 3.5 V.

For a common-anode RGB LED configuration, the buck-boost output voltage (V_{LED}) assumes a value such that the voltage drop across the sense resistor equals:

$$(SW4_IDAC[9:0] \text{Ivalue} + I_{LED}) \times R_{LIM} \quad (1)$$

The exact value of V_{LED} depends on the current setting and the voltage drop across the LED but is limited to 5.4 V. When the STROBE decoder switches from SW4 to SW5, the buck-boost assumes a new output voltage such that the sense voltage equals:

$$(SW5_IDAC[9:0] \text{Ivalue} + I_{LED}) \times R_{LIM} \quad (2)$$

$$(SW6_IDAC[9:0] \text{Ivalue} + I_{LED}) \times R_{LIM} \quad (3)$$

The relationship between V_{IN} , V_{LED} , and $MAX I_{LED}$ is shown in [Figure 4](#).

7.3.4 Calculating Inductor Peak Current

To properly configure the DLPA2000 device, a 2.2- μ H inductor must be connected between pin L1 and pin L2. The peak current for the inductor in steady state operation can be calculated.

[Equation 4](#) shows how to calculate the peak current I_1 in step down mode operation, and [Equation 5](#) shows how to calculate the peak current I_2 in boost mode operation. V_{IN1} is the maximum input voltage, V_{IN2} is the minimum input voltage, f is the switching frequency (2.25 MHz), and L the inductor value (2.2 μ H).

$$I_1 = \frac{I_{OUT}}{0.8} + \frac{V_{OUT} (V_{IN1} - V_{OUT})}{2 \times V_{IN1} \times f \times L} \quad (4)$$

$$I_2 = \frac{V_{OUT} \times I_{OUT}}{0.8 \times V_{IN2}} + \frac{V_{IN2} (V_{OUT} - V_{IN2})}{2 \times V_{OUT} \times f \times L} \quad (5)$$

The critical current value for selecting the right inductor is the higher value of I_1 and I_2 . Also consider that load transients and error conditions may cause higher inductor currents. This needs to be accounted for when selecting an appropriate inductor. Internally the switching current is limited to a maximum of 4 A.

7.3.5 LED Current Accuracy

The LED drive current is controlled by a current digital-to-analog converter (DAC) and can be set independently for switch SW4, SW5, and SW6. The DAC is trimmed at a current of 750 mA for the DLPA2000 at code: 0x307h. The DLPA2000 current step size is 0.95 mA.

First order gain-error of the DAC can be neglected, but an offset current error must be taken into account. This offset error differs depending on the used R_{LIM} and will be ± 25 mA for the DLPA2000 for a 100-m Ω current sense resistor.

The max current of the DLPA2000 ($SWx_IDAC[9:0] = 0x307h$) is regulated to 750 mA. At the lowest setting ($SWx_IDAC[9:0] = 0x001h$) the current is regulated to 14 mA for the DLPA2000. For this current setting (0x001h), the absolute current error results into a large relative error; however, this is not a typical operating point.

Be aware that the LED current setting not only depends on the accuracy of the R_{LIM} resistor, but also strongly depends on the added resistance of PCB traces and soldering quality. Due to the low value of the current sense resistor R_{LIM} , any extra introduced resistance (for example several m Ω) will result in a noticeable different LED current.

7.3.6 Transient Current Limiting

Typically the forward voltages of the green and blue diodes are close to each other (about 3 V to 4 V). However, the forward voltage of the red diode is significantly lower (1.8 V to 2.5 V). This can lead to a current spike in the red diode when the strobe controller switches from green or blue to red because VLED is initially at a higher voltage than required to drive the RED diode. DLPA2000 provides transient current limiting for each switch to limit the current in the LEDs during the transition. The transient current limit value is controlled through the ILIM[3:0] bits in the IREG register. The same register also contains three bits to select which switch employs the transient current limiting feature. In a typical application, the transient current limit will only apply to the RED diode, and the ILIM[3:0] value will typically be set approximately 10% higher than the DC regulation current. The effect that the transient current limit has on the LED current is shown in [Figure 9](#).

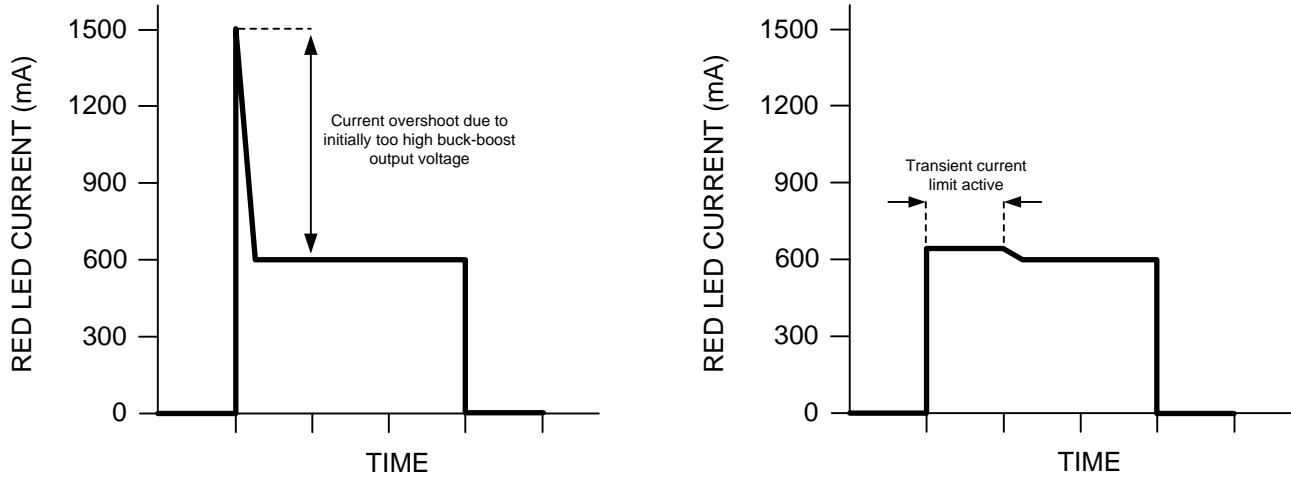

Red LED current without transient current limit. The current overshoots because the buck-boost voltage starts at the (higher) level of the green or blue LED.

LED current with transient current limit.

Figure 9. RED LED Current With and Without Transient Current Limit

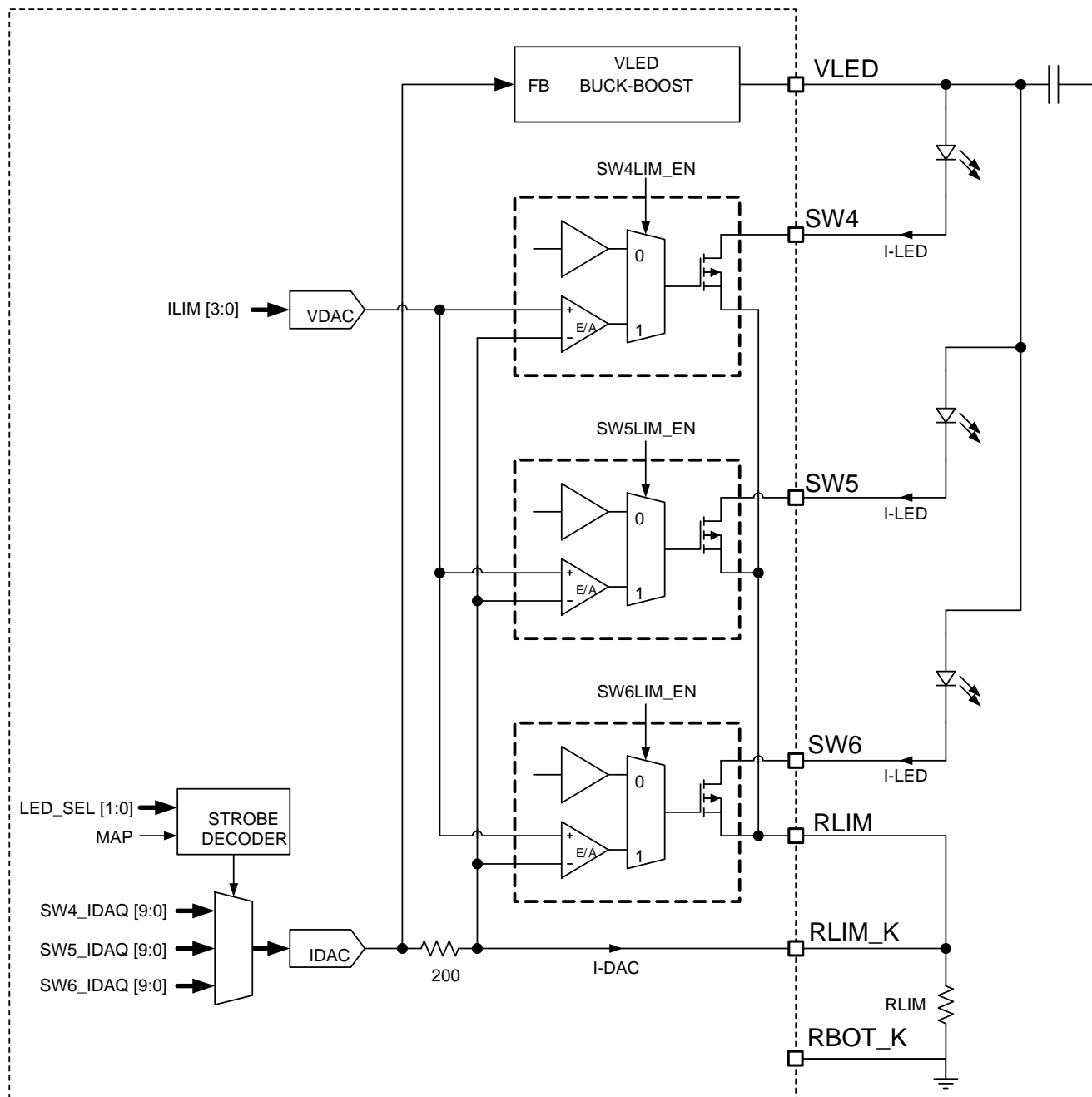

Figure 10. LED Driver Block Diagram

7.3.7 1.1-V Regulator (Buck Converter)

The buck converter creates a voltage of 1.1 V, and due to its switching nature, an output ripple with a frequency of approximately 2.25 MHz occurs on its output. This ripple is strongly dependent on the decoupling capacitor at the output in combination with the inductor. The magnitude of the ripple can be calculated with Equation 6.

$$\Delta V_{CORE} = V_{CORE} \times \frac{1 - \frac{V_{CORE}}{V_{INC}}}{L \times f} \times \left(\frac{1}{8 \times C_{OUT} \times f} + ESR \right) \quad (6)$$

The best way to minimize this ripple is to select a capacitor with a very-low ESR.

7.3.8 Motor Driver

Two control modes are available in the DLPA2000: IN/IN mode and PHASE/ENABLE mode. IN/IN mode is selected if the MODE pin is driven low or left unconnected; PHASE/ENABLE mode is selected if the MODE pin is driven to logic high. [Table 2](#) and [Table 3](#) show the logic for these modes.

The main difference between both modes is that to change the rotation direction for IN/IN mode, both xIN1 and xIN2 signals must change polarity, while for PHASE/ENABLE mode, the PHASE signal must be held high while the PHASE signal is used to change rotation direction for a DC motor. In case a stepper motor is used, the sequence of OUT1 and OUT2 determines the rotation direction.

The motor position is changed by using the internal, register-generated, control signals AIN1 and AIN2 (register 0F[123:122] in combination with BIN1 and BIN2 (register 0F[121:120]).

Table 2. IN/IN Mode (See [Figure 31](#))

MD_MODE BIT 124 REG 0Fh	xIN1	xIN2	xOUT1	xOUT2	FUNCTION (DC MOTOR)
0	0	0	Z	Z	Coast
0	0	1	L	H	Reverse
0	1	0	H	L	Forward
0	1	1	L	L	Brake

Table 3. PHASE/ENABLE Mode (See [Figure 31](#))

MD_MODE BIT 124 REG 0Fh	xIN1 (ENABLE)	xIN2 (PHASE)	xOUT1	xOUT2	FUNCTION (DC MOTOR)
1	0	X	L	L	Brake
1	1	1	L	H	Reverse
1	1	0	H	L	Forward

7.3.8.1 Motor Driver Overcurrent Protection

An analog current limit circuit on each FET limits the current through the FET by removing the gate drive. If this analog current limit persists for a longer period of time than the overcurrent deglitch time, all FETs in the H-bridge will be disabled. After approximately 1 ms, the bridge will be re-enabled automatically.

7.3.9 Measurement System

The measurement system is composed of a 10:1 analog multiplexer (MUX), a programmable-gain amplifier, and a comparator. It works together with the DPP processor to provide:

- White-point correction (WPC) by independently adjusting the RGB LED currents after measuring the brightness of each color with an external light sensor
- A measurement of the:
 - Battery voltage
 - LED forward voltage
 - Exact LED current
 - Temperature as derived by measuring the voltage across an external thermistor

[Figure 11](#) shows a block diagram of the measurement system.

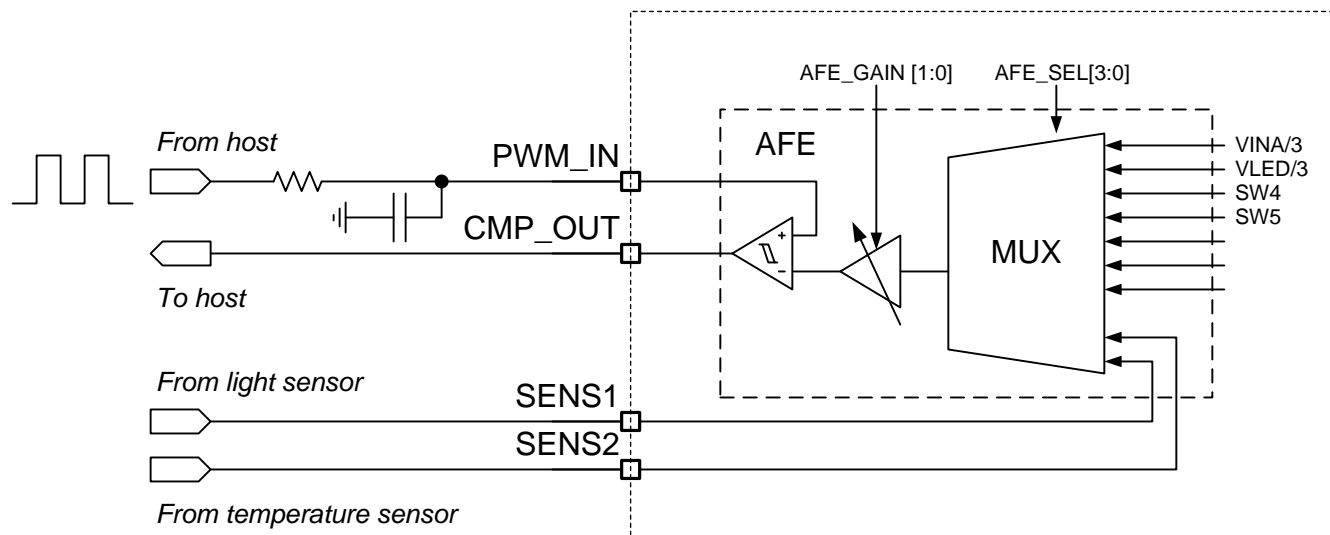

Figure 11. Block Diagram of the Measurement System

Table 4. Recommended Configuration of the AFE for Different Input Selections

AFE_SEL[3:0]	SELECTED INPUT	RECOMMENDED GAIN SETTING AFE-GAIN[1:0]	RECOMMENDED SETTING OF AFE_CAL_DIS BIT
0x00h	SENS2	0x01h (1x)	Setting has no effect on measurement.
0x01h	VLED	0x01h (1x)	Setting has no effect on measurement.
0x02h	VINA	0x01h (1x)	Setting has no effect on measurement.
0x03h	SENS1	0x01h (1x)	Setting has no effect on measurement.
0x04h	RLIM_K	0x03h (18x)	Set to 1 if sense voltage is >100 mV. Otherwise set to 0 (default).
0x05h	SW4	0x02h (9.5x)	Set to 1 if sense voltage is >200 mV. Otherwise set to 0 (default).
0x06h	SW5	0x02h (9.5x)	Set to 1 if sense voltage is >200 mV. Otherwise set to 0 (default).
0x07h	SW6	0x02h (9.5x)	Set to 1 if sense voltage is >200 mV. Otherwise set to 0 (default).
0x08h	No connect	N/A	N/A.
0x09h	VREF	0x01h (1x)	Setting has no effect on measurement.

7.3.10 Protection Circuits

DLPA2000 has several protection circuits to protect the IC and system from damage due to excessive power consumption, die temperature, or over-voltages. These circuits are described in the following sections.

7.3.10.1 Thermal Warning (HOT) and Thermal Shutdown (TSD)

DLPA2000 continuously monitors the junction temperature and issues a HOT interrupt if temperature exceeds the HOT threshold. If the temperature continues to increase above the thermal shutdown threshold, all rails are disabled and the TSD bit in the INT register is set. After the temperature drops below its threshold, the system recovers and waits for the DPP to resend the DMD_EN bit.

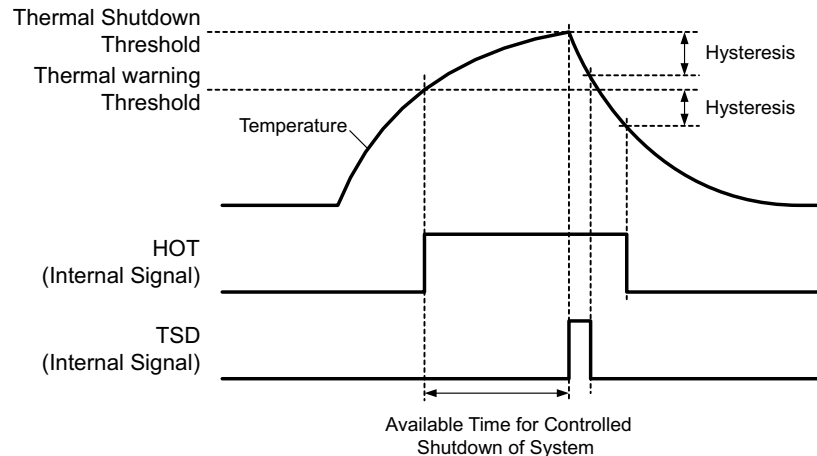

Figure 12. Definition of the Thermal Shutdown and Hot-Die Temperature Warning

7.3.10.2 Low Battery Warning (BAT_LOW) and Undervoltage Lockout (UVLO)

If the battery voltage drops below the BAT_LOW threshold (typically 3.0 V) the BAT_LOW interrupt is issued, but normal operation continues. After the battery drops below the undervoltage threshold which has a default hardcoded value of 2.3 V (this UVLO voltage can be changed through register 09h from 2.3 V to 4.5 V), the UVLO interrupt is issued, all rails are powered down in sequence, the DMD_EN bit is reset, and the part enters STANDBY mode. The power rails cannot be re-enabled before the input voltage recovers to >2.4 V. To re-enable the rails, the PROJ_ON pin must be toggled. The undervoltage threshold is programmable from 2.3 V to 4.5 V in 31 steps.

The UVLO shutdown process will protect the DMD by allowing time for the mirrors to park, then doing a fast discharge of V_{OFS} , V_{RST} , and V_{BIAS} . This protection occurs even in the case of sudden battery removal from the projector, as long as the bulk capacitance on the battery voltage (V_{INx}) keeps this voltage above 2.3 V for as long as needed for V_{OFS} , V_{RST} , and V_{BIAS} to discharge to the required safe levels as shown in the DMD data sheet. V_{OFS} , V_{RST} , and V_{BIAS} discharge times depend on the load capacitance on each regulator. When for instance every supply is decoupled using a capacitor of 0.5 μ F, V_{INx} should stay above 2.3 V for at least 100 μ s after the battery is suddenly removed. During this time, the mirrors can be placed in a safe position and V_{OFS} , V_{RST} , and V_{BIAS} can be discharged.

NOTE

As required by the DMD data sheet, LS_OUT must stay above 1.65 V until V_{OFS} , V_{RST} , and V_{BIAS} have discharged to their required safe levels.

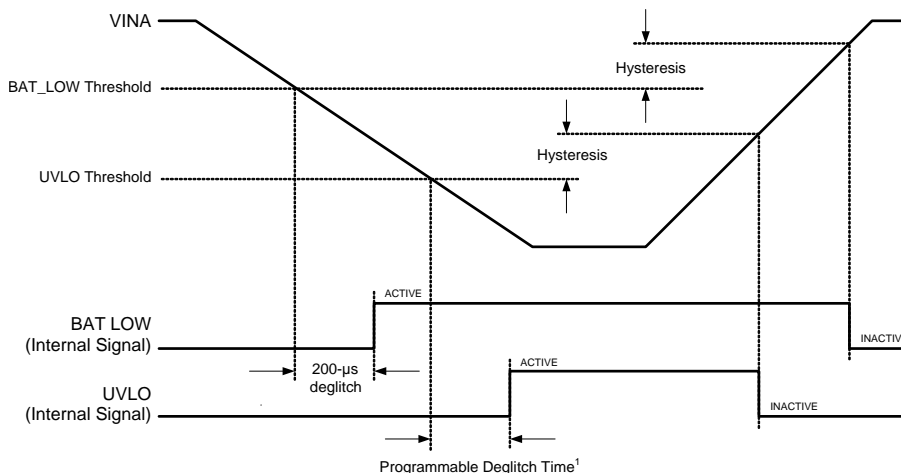

A. This time is programmable from 0 to 100 μ s.

Figure 13. UVLO is Asserted When the Input Supply Drops Below the UVLO Threshold

7.3.10.3 DMD Regulator Fault (DMD_FLT)

The DMD regulator is continuously monitored to check if the output rails are in regulation and if the inductor current increases as expected during a switching cycle. If either one of the output rails drops out of regulation (for example, due to a shorted output) or the inductor current does not increase as expected during a switching cycle (due to a disconnected inductor), the DMD_FLT interrupt bit is set in the INT register, the DMD_EN bit is reset, and the DMD regulator is shut down. Resetting the DMD_EN bit also causes the LED driver to power down. To restart the system, the PROJ_ON pin must be toggled. In case the interrupt is masked, it is sufficient to set the DMD_EN bit to restart the system.

7.3.10.4 V_{6V} Power-Good (V_{6V_PGF}) Fault

The LED driver regulation loop requires the V_{6V} rail for proper operation. The rail is continuously monitored and should the output drop below the power-good threshold, the V_{6V_PGF} bit is set. The V_{LED} buck-boost is then disabled and attempts to restart automatically.

7.3.10.5 V_{LED} Overvoltage (V_{LED_OVP}) Fault

If the buck-boost output voltage rises above 5.4 V, the V_{LED_OVP} interrupt is set but the buck-boost regulator is not turned off. A typical condition to cause this fault is an open LED.

7.3.10.6 V_{LED} Power Save Mode

In normal PWM operation, the efficiency of the V_{LED} buck-boost converter dramatically reduces for LED currents below 100 mA. In this case, the power save mode allows high converting efficiency at low output currents by skipping pulses in the switcher's gate driver control.

7.3.10.7 V_{1V8} PG Failure

If for any reason the voltage on the LS_OUT drops below approximately 1.3 V, then V_{OFS} , V_{BIAS} , and V_{RST} immediately go into fast shut down. Holding off power down to do mirror parking is not included since 1.3 V is too low to wait for this. Reactivating can only be done by toggling the PROJ_ON off and on again.

7.3.10.8 Interrupt Pin (INTZ)

The interrupt pin is used to signal events and fault conditions to the host processor. Whenever a fault or event occurs in the IC, the corresponding interrupt bit is set in the INT register, and the open-drain output is pulled low. The INTZ pin is released (returns to HiZ state) and fault bits are cleared when the INT register is read by the host.

However, if a failure persists, the corresponding INT bit remains set and the INTZ pin is pulled low again after a maximum of 32 μ s.

Interrupt events include fault conditions such as power-good faults, over-voltage, over-temperature shutdown, and UVLO. For all interrupt conditions see the interrupt register on [Figure 28](#).

The MASK register is used to mask events from generating interrupts, that is, from pulling the INTZ pin low. The MASK settings affect the INTZ pin only and have no impact on protection and monitor circuits themselves. When an interrupt is masked, the event causing the interrupt still sets the corresponding bit in the INT register. However, it does not pull the INTZ pin low.

7.3.10.9 SPI

DLPA2000 provides a 4-wire SPI port that supports high-speed serial data transfers up to 33.3 MHz. Support includes register and data buffer write and read operations. The SPI_CSZ input serves as the active low chip select for the SPI port. The SPI_CSZ input must be forced low in order to write or read registers and data buffers. When SPI_CSZ is forced high, the data at the SPI_DIN input is ignored, and the SPI_DOUT output is forced to a high-impedance state. The SPI_DIN input serves as the serial data input for the port; the SPI_DOUT output serves as the serial data output. The SPI_CLK input serves as the serial data clock for both the input and output data. Data is latched at the SPI_DIN input on the rising edge of SPI_CLK, while data is clocked out of the SPI_DOUT output on the falling edge of SPI_CLK. [Figure 14](#) shows the SPI port protocol. Byte 0 is referred to as the command byte, where the most significant bit is the write/not read bit. For the W/nR bit, a 1 indicates a write operation, while a 0 indicates a read operation. The remaining seven bits of the command byte are the register address targeted by the write or read operation. The SPI port supports write and read operations for multiple sequential register addresses through the implementation of an auto-increment mode. As shown in [Figure 14](#), the auto-increment mode is invoked by simply holding the SPI_CSZ input low for multiple data bytes. The register address is automatically incremented after each data byte transferred, starting with the address specified by the command byte. After reaching address 0x7Fh the address pointer jumps back to 0x00h.

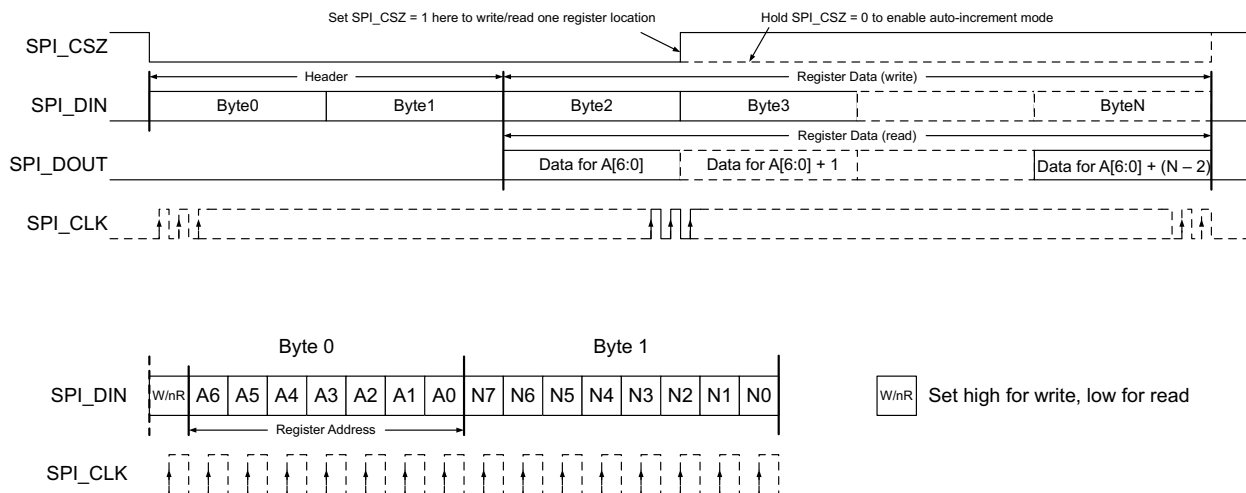

Figure 14. SPI Protocol

7.3.11 Password Protected Registers

Register addresses 0x11h through 0x27h can be read-accessed the same way as any other register, but are protected against accidental write operations through the PASSWORD register (address 0x10h). To write to a protected register, follow these steps:

1. Write data 0xBAh to register address 0x10h.
2. Write data 0xBEh to register address 0x10h.

Both writes must be consecutive, that is, there must be no other read or write operation in between sending the two bytes. After the password has been successfully written, registers 0x11h through 0x27h are unlocked and can be write accessed using the regular SPI protocol. They remain unlocked until any byte other than 0xBAh is written to the PASSWORD register or the part is power cycled.

To check if the registers are unlocked, read back the PASSWORD register. If the data returned is 0x00h, the registers are locked. If the PASSWORD register returns 0x01h, the registers are unlocked.

7.4 Device Functional Modes

Table 5. Modes of Operation

MODE	DESCRIPTION
OFF	This is the lowest-power mode of operation. All power functions are turned off, registers are reset to their default values, and the IC does not respond to SPI commands. RESETZ pin is pulled low. The IC will enter OFF mode whenever the PROJ_ON pin is low.
STANDBY	The DMD regulators and LED power (V_{LED}) are turned off, but the IC does respond to the SPI. The device enters STANDBY mode whenever PROJ_ON is set high or DMD_EN ⁽¹⁾ bit is set to 0 using the SPI interface after PROJ_ON is already high. The device also enters STANDBY mode when a fault condition is detected ⁽²⁾ . (See Protection Circuits).
ACTIVE1	The DMD supplies are enabled but LED power (V_{LED}) is disabled. PROJ_ON pin must be high, DMD_EN bit must be set to 1, and V_{LED_EN} ⁽³⁾ bit is set to 0.
ACTIVE2	DMD supplies and LED power are enabled. PROJ_ON pin must be high and DMD_EN and V_{LED_EN} bits must both be set to 1.

(1) Settings can be done through Reg01h [9] and Reg2E [119].

(2) Power-good faults, over-voltage, overtemperature shutdown, and undervoltage lockout.

(3) Settings can be done through Reg47h [60], bit is named $V_{LED_EN_SET}$.

Table 6. Device State as a Function of Control-Pin Status

PROJ_ON PIN	STATE
LOW	OFF
HIGH	STANDBY ACTIVE1 ACTIVE2 (Device state depends on DMD_EN and V_{LED_EN} bits and whether there are any fault conditions.)

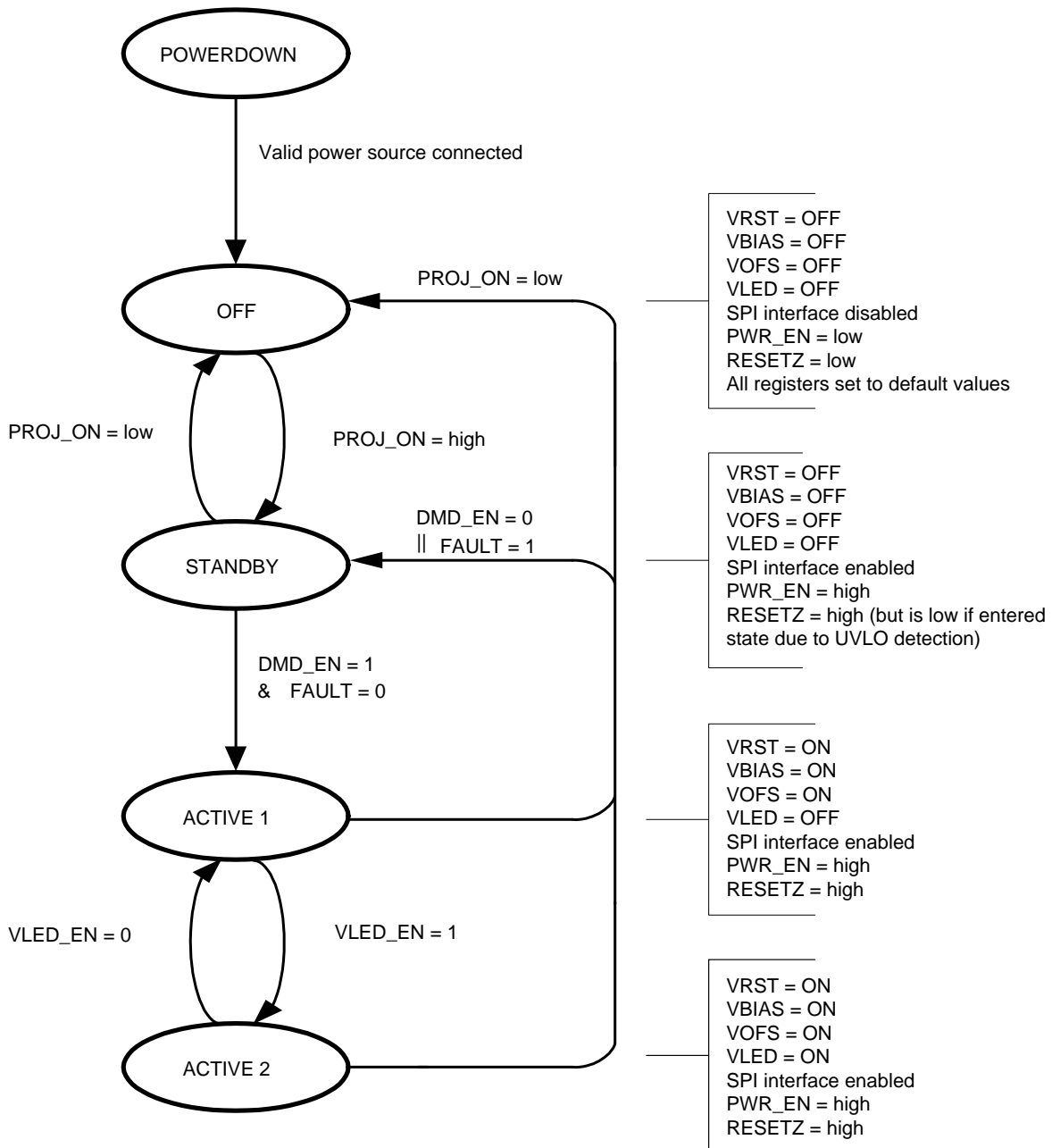

- A. || = OR, & = AND.
- B. FAULT = Undervoltage on any supply (except LS_OUT), thermal shutdown, or UVLO detection.
- C. UVLO detection, per the diagram, causes the DLPA2000 to go into the standby state. This is not the lowest power state. If lower power is desired, PROJ_ON should be set low.
- D. DMD_EN register bit can be reset or set by SPI writes. DMD_EN defaults to 0 when PROJ_ON goes from low to high and then the DPP ASIC software automatically sets it to 1. Also, FAULT = 1 causes the DMD_EN register bit to be reset.
- E. PWR_EN is a signal internal to the PAD200x. This signal turns on the VCORE regulator and the load switch that drives pin LS_OUT.

Figure 15. State Diagram

7.5 Register Maps

Table 7. Register Description

REGISTER	ADDRESS (HEX)	NAME	TABLE	DESCRIPTION	DEFAULT
USER CONFIGURATION DEFINITIONS					
R	0x00	CHIP ID	Figure 16	Chip revision register; DLPA2000	B3
R/W	0x01	CHIPENABLE	Figure 17	Enable register	0F
R/W	0x02	IREG	Figure 18	Transient-current limit settings	30
R/W	0x03	SW4MSB	Figure 19	Regulation current MSB, SW4	0
R/W	0x04	SW4LSB	Table 12, Table 13	Regulation current LSB, SW4	0
R/W	0x05	SW5MSB	Figure 21	Regulation current MSB, SW5	0
R/W	0x06	SW5LSB	Figure 22, Table 16	Regulation current LSB, SW5	0
R/W	0x07	SW6MSB	Figure 23	Regulation current MSB, SW6	0
R/W	0x08	SW6LSB	Figure 24, Table 19	Regulation current LSB, SW6	0
R/W	0x09	SWCNTRL	Figure 25	Switch ON/OFF control (direct mode)	0
R/W	0x0A	AFE	Figure 26	AFE (MUX) control	0
R/W	0x0B	BBM	Figure 27, Table 22	Break before make timing	0
R	0x0C	INT	Figure 28, Table 23	Interrupt register	0
R/W	0x0D	INT MASK	Figure 29, Table 24	Interrupt mask register	DFh
R/W	0x0E	TIMING	Figure 30, Table 26	Timing register V_{OFS} , V_{BIAS} , V_{RST} , and RESETZ	7
R/W	0x0F	MOTOR CTRL	Figure 31, Table 27	Motor control register	0
USER PROTECTED DEFINITION					
R/W	0x10	PASSWORD	Figure 32	Password register	0
R/W	0x11	SYSTEM	Figure 33	System configuration register	0
USER EEPROM SCRATCH PAD DEFINITION					
R/W	0x20	BYTE0	Figure 34	User EEPROM, Byte0	0
R/W	0x21	BYTE1	Figure 35	User EEPROM, Byte1	0
R/W	0x22	BYTE2	Figure 36	User EEPROM, Byte2	0
R/W	0x23	BYTE3	Figure 37	User EEPROM, Byte3	0
R/W	0x24	BYTE4	Figure 38	User EEPROM, Byte4	0
R/W	0x25	BYTE5	Figure 39	User EEPROM, Byte5	0
R/W	0x26	BYTE6	Figure 40	User EEPROM, Byte6	0
R/W	0x27	BYTE7	Figure 41	User EEPROM, Byte7	0

7.5.1 Chip Revision Register

Figure 16. Chip Revision Register, Address = 00h, HEX = B3

7	6	5	4	3	2	1	0
CHIP ID [7:0]							
R	R	R	R	R	R	R	R

LEGEND: R/W = Read/Write; R = Read only; -n = value after reset.

Table 8. Chip Revision Register Field Descriptions

BIT	FIELD	TYPE	RESET	DESCRIPTION
7:4	CHIP ID	R	1011	CHIPID<3:0>
3:0		R	0011	REVID<3:0>

7.5.2 Enable Register

Figure 17. Enable Register, Address = 01h, HEX = 0F

7	6	5	4	3	2	1	0
CHIPENABLE [15:8]							
R/W	R/W	R/W	R/W	R/W	R/W	R/W	R/W

LEGEND: R/W = Read/Write; R = Read only; -n = value after reset

Table 9. Enable Register Field Descriptions

BIT	FIELD	TYPE	RESET	DESCRIPTION
15:12	CHIPENABLE	R/W	0000	USER_GPO<3:0>
11		R/W	1	VLED_POWER_SAVE_MODE_DIS Power save mode is used to improve efficiency at light load.
10		R/W	1	FAST_SHUTDOWN_EN Applicable only during a fault condition. Shutdown timing is defined by register 0Eh (see Figure 7).
9		R/W	1	DMD_EN
8		R/W	1	VLED_EN

7.5.3 Transient-Current Limit Settings

Figure 18. Transient-Current Limit Settings, Address = 02h, HEX = 30

7	6	5	4	3	2	1	0
IREG [23:16]							
R/W	R/W	R/W	R/W	R/W	R/W	R/W	R/W

LEGEND: R/W = Read/Write; R = Read only; -n = value after reset.

Table 10. Transient-Current Limit Settings Field Descriptions

BIT	FIELD	TYPE	RESET	DESCRIPTION	
23	RSVD	R/W	0	Not used	
22:19	IREG	R/W	0110	IREG_ILIM<3:0>	
				$R_{LIM} = 100 \text{ m}\Omega$	
				0000	130 mA
				0001	150 mA
				0010	172 mA
				0011	192 mA
				0100	220 mA
				0101	275 mA
				0110	330 mA
				0111	440 mA
				1000	550 mA
				1001	660 mA
				1010	770 mA
18	SW6LIM_EN	R/W	0	SW6LIM_EN Transient current-limit enable for SW6 0 – Transient current-limit is disabled 1 – Transient current-limit is enabled	

Table 10. Transient-Current Limit Settings Field Descriptions (continued)

BIT	FIELD	TYPE	RESET	DESCRIPTION
17	SW5LIM_EN	R/W	0	SW5LIM_EN Transient current-limit enable for SW5 0 – Transient current-limit is disabled 1 – Transient current-limit is enabled
16	SW4LIM_EN	R/W	0	SW4LIM_EN Transient current-limit enable for SW4 0 – Transient current-limit is disabled 1 – Transient current-limit is enabled

7.5.4 Regulation Current MSB, SW4

Figure 19. Regulation Current MSB, SW4, Address = 03h, HEX = 00

7	6	5	4	3	2	1	0
SW4MSB [31:24]							
R/W	R/W	R/W	R/W	R/W	R/W	R/W	R/W

LEGEND: R/W = Read/Write; R = Read only; -n = value after reset.

Table 11. Regulation Current MSB, SW4 Field Descriptions⁽¹⁾

BIT	FIELD	TYPE	RESET	DESCRIPTION
31:26	SW4MSB	R/W	0000	TBD
25:24		R/W	0000	SW4_IDAC<9:8>

(1) The DLPA2000 can use up to code 0x0FFh for SW4_IDAC[9:0].

7.5.5 Regulation Current LSB, SW4

Figure 20. Regulation Current LSB, SW4, Address = 04h, HEX = 00

7	6	5	4	3	2	1	0
SW4LSB [39:32]							
R/W	R/W	R/W	R/W	R/W	R/W	R/W	R/W

LEGEND: R/W = Read/Write; R = Read only; -n = value after reset.

Table 12. Regulation Current LSB, SW4 Field Descriptions

BIT	FIELD	TYPE	RESET	DESCRIPTION
39:32	SW4LSB	R/W	00000000	SW4_IDAC<7:0>

Table 13. Regulation Current LSB, SW4 Bit Definitions

DLPA2000 ⁽¹⁾⁽²⁾					
SW4_IDAC[9:0]	LED CURRENT	SW4_IDAC[9:0]	LED CURRENT	SW4_IDAC[9:0]	LED CURRENT
0x000h	0 mA	0x100h	257 mA	0x200h	500 mA
0x00Ch	25 mA	0x101h	258 mA	0x201h	501 mA
0x00Dh	26 mA	0x102h	259 mA	0x202h	502 mA
...
0x0FEh	255 mA	0x1FEh	498 mA	0x306h	749 mA
0x0FFh	256 mA	0x1FFh	499 mA	0x307h	750 mA

(1) Values shown are for a typical DLPA2000 unit at T = 25°C. Typical step size is 0.95 mA for R_{LIM} = 100 mΩ.

(2) The DLPA2000 can use up to code 0x307h for SW4_IDAC[9:0].

7.5.6 Regulation Current MSB, SW5
Figure 21. Regulation Current MSB, SW5, Address = 05h, HEX = 00

7	6	5	4	3	2	1	0
SW5MSB [47:40]							
R/W	R/W	R/W	R/W	R/W	R/W	R/W	R/W

LEGEND: R/W = Read/Write; R = Read only; -n = value after reset.

Table 14. Regulation Current MSB, SW5 Field Descriptions⁽¹⁾

BIT	FIELD	TYPE	RESET	DESCRIPTION
47:42	SW5MSB	R/W	0000	TBD
41:40		R/W	0000	SW5_IDAC<9:8>

(1) The DLPA2000 can use up to code 0x0FFh for SW5_IDAC[9:0].

7.5.7 Regulation Current LSB, SW5
Figure 22. Regulation Current LSB, SW5, Address = 06h, HEX = 00

7	6	5	4	3	2	1	0
SW5LSB [55:48]							
R/W	R/W	R/W	R/W	R/W	R/W	R/W	R/W

LEGEND: R/W = Read/Write; R = Read only; -n = value after reset.

Table 15. Regulation Current LSB, SW5 Field Descriptions

BIT	FIELD	TYPE	RESET	DESCRIPTION
55:48	SW5LSB	R/W	00000000	SW5_IDAC<7:0>

Table 16. Regulation Current LSB, SW5 Bit Definitions

DLPA2000 ⁽¹⁾⁽²⁾					
SW5_IDAC[9:0]	LED CURRENT	SW5_IDAC[9:0]	LED CURRENT	SW5_IDAC[9:0]	LED CURRENT
0x000h	0 mA	0x100h	257 mA	0x200h	500 mA
0x00Ch	25 mA	0x101h	258 mA	0x201h	501 mA
0x00Dh	26 mA	0x102h	259 mA	0x202h	502 mA
...
0x0FEh	255 mA	0x1FEh	498 mA	0x306h	749 mA
0x0FFh	256 mA	0x1FFh	499 mA	0x307h	750 mA

 (1) Values shown are for a typical DLPA2000 unit at T = 25°C. Typical step size is 0.95 mA for R_{LIM} = 100 mΩ.

(2) The DLPA2000 can use up to code 0x307h for SW5_IDAC[9:0].

7.5.8 Regulation Current MSB, SW6

Figure 23. Regulation Current MSB, SW6, Address = 07h, HEX = 00

7	6	5	4	3	2	1	0
SW6MSB [63:56]							
R/W	R/W	R/W	R/W	R/W	R/W	R/W	R/W

LEGEND: R/W = Read/Write; R = Read only; -n = value after reset.

Table 17. Regulation Current MSB, SW6 Field Descriptions⁽¹⁾

BIT	FIELD	Type	Reset	Description
63:58	SW6MSB	R/W	0000	TBD
57:56		R/W	0000	SW6_IDAC<9:8>

(1) The DLPA2000 can use up to code 0x0FFh for SW6_IDAC[9:0].

7.5.9 Regulation Current LSB, SW6

Figure 24. Regulation Current LSB, SW6, Address = 08h, HEX = 00

7	6	5	4	3	2	1	0
SW6LSB [71:64]							
R/W	R/W	R/W	R/W	R/W	R/W	R/W	R/W

LEGEND: R/W = Read/Write; R = Read only; -n = value after reset.

Table 18. Regulation Current LSB, SW6 Field Descriptions

BIT	FIELD	TYPE	RESET	DESCRIPTION
71:64	SW6LSB	R/W	00000000	SW6_IDAC<7:0>

Table 19. Regulation Current LSB, SW6 Bit Definitions

DLPA2000 ⁽¹⁾⁽²⁾					
SW6_IDAC[9:0]	LED CURRENT	SW6_IDAC[9:0]	LED CURRENT	SW6_IDAC[9:0]	LED CURRENT
0x000h	0 mA	0x100h	257 mA	0x200h	500 mA
0x00Ch	25 mA	0x101h	258 mA	0x201h	501 mA
0x00Dh	26 mA	0x102h	259 mA	0x202h	502 mA
...
0x0FEh	255 mA	0x1FEh	498 mA	0x306h	749 mA
0x0FFh	256 mA	0x1FFh	499 mA	0x307h	750 mA

(1) Values shown are for a typical DLPA2000 unit at T = 25°C. Typical step size is 0.95 mA for R_{LIM} = 100 mΩ.

(2) The DLPA2000 can use up to code 0x307h for SW6_IDAC[9:0].

7.5.10 Switch On/Off Control (Direct Mode)

Figure 25. Switch On/Off Control (Direct Mode), Address = 09h, HEX = 00

7	6	5	4	3	2	1	0
SWCNTRL [79:72]							
R/W	R/W	R/W	R/W	R/W	R/W	R/W	R/W

LEGEND: R/W = Read/Write; R = Read only; -n = value after reset.

Table 20. Switch On/Off Control (Direct Mode) Field Descriptions

BIT	FIELD	TYPE	RESET	DESCRIPTION			
79	SWCNTRL	R/W	0	SW6 (controls switch 6 if direct mode (see reg 11h) is enabled)	00000 00001 11110 11111	2.3 V (minimum value – default value) 2.37 V Step approximately 70 mV 4.43 V 4.5 V (maximum value)	
78		R/W	0	SW5 (controls switch 5 if direct mode (see reg 11h) is enabled)			
77		R/W	0	SW4 (controls switch 4 if direct mode (see reg 11h) is enabled)			
76:72		R/W	00000	UVLO_TRIM<4:0>			

7.5.11 AFE (MUX) Control

Figure 26. AFE (MUX) Control, Address = 0Ah, HEX = 00

7	6	5	4	3	2	1	0
AFE [87:80]							
R/W	R/W	R/W	R/W	R/W	R/W	R/W	R/W

LEGEND: R/W = Read/Write; R = Read only; -n = value after reset.

Table 21. AFE (MUX) Control Field Descriptions

BIT	FIELD	TYPE	RESET	DESCRIPTION
87	AFE	R/W	00	AFE_EN
86		R/W	00	AFE_CAL_DIS
85:84		R/W	00	AFE_GAIN<1:0>
83:80		R/W	00	AFE_SEL<3:0>

7.5.12 Break Before Make (BBM) Timing

Figure 27. BBM Timing, Address = 0Bh, HEX = 00

7	6	5	4	3	2	1	0
BBM [95:88]							
R/W	R/W	R/W	R/W	R/W	R/W	R/W	R/W

LEGEND: R/W = Read/Write; R = Read only; -n = value after reset.

Table 22. BBM Timing Field Descriptions⁽¹⁾

BIT	FIELD	TYPE	RESET	DESCRIPTION			
95:88	BBM	R/W	00000000	BBM_DELAY<7:0>			
				0x00 – 0 ns	0x40 – 7326 ns	0x80 – 14430 ns	0xC0 – 21534 ns
				0x01 – 333 ns	0x41 – 7437 ns	0x81 – 14541 ns	0xC1 – 21645 ns
				0x02 – 444 ns	0x42 – 7548 ns	0x82 – 14652 ns	0xC2 – 21756 ns
			
				0x3E – 7104 ns	0x7E – 14208 ns	0xBE – 21312 ns	0xFE – 28416 ns
				0x3F – 7215 ns	0x7F – 14319 ns	0xBF – 21423 ns	0xFF – 28527 ns

(1) It takes 333 to 444 ns to turn off the switches from the time a change occurs on LED_SEL[1:0].

7.5.13 Interrupt Register

Figure 28. Interrupt Register, Address = 0Ch, HEX = 00

7	6	5	4	3	2	1	0
INT [103:96]							
R	R	R	R	R	R	R	R

LEGEND: R/W = Read/Write; R = Read only; -n = value after reset.

Table 23. Interrupt Register Field Descriptions

BIT	FIELD	TYPE	RESET	DESCRIPTION
103	INT	R	0	V_{LED_OVP} $V_{LED_buck_boost}$ overvoltage fault interrupt (normal operation resumes) 0 – No fault 1 – Buck_boost output is above OVP threshold
102		R	0	IREG_PG_FAULT V_{6V} power-good fault interrupt (normal operation resumes) 0 – No fault 1 – V_{6V} is not in regulation
101		R	0	PROJ_ON_INT Proj_On interrupt (part enters OFF mode) 0 – Pin is pulled high, normal mode 1 – Pin is pulled low, alerts the DPP that the DMD regulator is about to shut down.
100		R	0	DMD_FAULT DMD regulator fault (part enters STANDBY mode and DMD_EN bit is cleared) 0 – No fault 1 – The inductor current is not increasing at the correct rate, likely to be caused by an open inductor. Or, one of the regulator outputs has dropped below the power-good threshold, likely to be caused by a short.
99		R	0	UVLO UVLO interrupt (sensed at V_{INA} pin), DMD bit is cleared. 0 – Battery voltage is above the UVLO threshold. 1 – Battery voltage has dropped below the UVLO threshold.
98		R	0	BAT_LOW_WARN Low battery warning interrupt (sensed at V_{INA} pin, normal operation resumes) 0 – Battery voltage is above the low-battery threshold 1 – Battery voltage has dropped below the low-battery threshold
97		R	0	TS_WARN Thermal warning interrupt (normal operation resumes) 0 – Die temperature is in normal operating range 1 – Die temperature is above the HOT threshold Or, part has not cooled down enough to recover from HOT.
96		R	0	TS_WARN Thermal Warning Interrupt (normal operation resumes) 0 – Die temperature is in normal operating range 1 – Die temperature is above the HOT threshold Or, part has not cooled down enough to recover from HOT.

7.5.14 Interrupt Mask Register
Figure 29. Interrupt Mask Register, Address = 0Dh, HEX = DF

7	6	5	4	3	2	1	0
INT MASK [111:104]							
R/W	R/W	R/W	R/W	R/W	R/W	R/W	R/W

LEGEND: R/W = Read/Write; R = Read only; -n = value after reset.

Table 24. Interrupt Mask Register Field Descriptions

BIT	FIELD	TYPE	RESET	DESCRIPTION
111	INT MASK	R/W	1	V _{LED} BUCK_BOOST Overvoltage fault interrupt mask 0 – Interrupt is not masked 1 – Interrupt is masked
110		R/W	1	I _{REG_PG_FAULT_MASK} 0 – Interrupt is not masked 1 – Interrupt is masked
109		R/W	0	PROJ_ON interrupt mask 0 – Interrupt is not masked 1 – Interrupt is masked
108		R/W	1	DMD_REGULATOR fault mask 0 – Interrupt is not masked 1 – Interrupt is masked
107		R/W	1	UVLO_MASK 0 – Interrupt is not masked 1 – Interrupt is masked
106		R/W	1	Low battery warning mask (sensed at V _{INA} pin) 0 – Interrupt is not masked 1 – Interrupt is masked
105		R/W	1	Thermal shutdown interrupt mask 0 – Interrupt is not masked 1 – Interrupt is masked
104		R/W	1	Thermal warning interrupt mask 0 – Interrupt is not masked 1 – Interrupt is masked

7.5.15 Timing Register V_{OFS} , V_{BIAS} , V_{RST} , and RESETZ
Figure 30. Timing Register V_{OFS} , V_{BIAS} , V_{RST} , and RESETZ, Address = 0Eh, HEX = 07

7	6	5	4	3	2	1	0
TIMING [119:112]							
R/W	R/W	R/W	R/W	R/W	R/W	R/W	R/W

LEGEND: R/W = Read/Write; R = Read only; -n = value after reset.

Table 25. Timing Register VOFS, VBIAS, VRST, and RESETZ Field Descriptions

BIT	FIELD	TYPE	RESET	DESCRIPTION
119:116	TIMING	R/W	0000	$V_{OFS}/RESETZ_DELAY<3:0>$ (for values see minimum and maximum delay)
115:112		R/W	0111	$V_{BIAS}/V_{RST_DELAY<3:0>}$ (for values see minimum and maximum delay)

Table 26. Timing Register V_{OFS} , V_{BIAS} , V_{RST} , and RESETZ Bit Definitions

FIELD NAME	BIT	BIT DEFINITION		
			Minimum Delay (μ s)	Maximum Delay (μ s)
TIMING	[119:112]	0000	4.0	4.4
		0001	8.0	8.9
		0010	16.0	17.8
		0011	32.0	35.5
		0100	64.0	71.1
		0101	128.0	142.2
		0110	256.0	284.4
		0111	512.0	569.0
		1000	6.2	7.1
		1001	12.4	14.2
		1010	24.9	28.4
		1011	49.8	56.9
		1100	99.5	113.8
		1101	199.1	227.6
		1110	398.3	455.2
		1111	1024.2	1138.0

7.5.16 Motor Control Register

Figure 31. Motor Control Register, Address = 0Fh, HEX = 00⁽¹⁾

7	6	5	4	3	2	1	0
MOTOR CTRL [127:120]							
R/W	R/W	R/W	R/W	R/W	R/W	R/W	R/W

LEGEND: R/W = Read/Write; R = Read only; -n = value after reset.

 (1) V_{INM} can be left floating if the motor controller is not used.

Table 27. Motor Control Register Field Descriptions

BIT	FIELD	TYPE	RESET	DESCRIPTION
127	MOTOR CTRL	R/W	0	TBD
126		R/W	0	TBD
125		R/W	0	MD_EN
124		R/W	0	MD_MODE
123		R/W	0	MD_AIN1
122		R/W	0	MD_AIN2
121		R/W	0	MD_BIN1
120		R/W	0	MD_BIN2

7.5.17 Password Register

Figure 32. Password Register, Address = 10h, HEX = 00

7	6	5	4	3	2	1	0
PASSWORD [135:128]							
R/W	R/W	R/W	R/W	R/W	R/W	R/W	R/W

LEGEND: R/W = Read/Write; R = Read only; -n = value after reset

Table 28. Password Register Field Descriptions

BIT	FIELD	TYPE	RESET	DESCRIPTION
135:128	PASSWORD	R/W	00000000	USER PASSWORD (0xBAh + 0xBEh) disable (0x00h). Once set, register 11h can be written.

7.5.18 System Configuration Register

Figure 33. System Configuration Register, Address = 11h, HEX = 00

7	6	5	4	3	2	1	0
SYSTEM [143:136]							
R/W	R/W	R/W	R/W	R/W	R/W	R/W	R/W

LEGEND: R/W = Read/Write; R = Read only; -n = value after reset.

Table 29. System Configuration Register Field Descriptions

BIT	FIELD	TYPE	RESET	DESCRIPTION
143:139	SYSTEM	R/W	00000	TBD
138		R/W	0	EEPROM_PROGRAM Program scratch pad values to EEPROM
137		R/W	0	DIRECT_MODE Allows direct control of switches through SW CONTROL REGISTER
136		R/W	0	TBD

7.5.19 User EEPROM, BYTE0

Figure 34. User EEPROM, BYTE0, Address = 20h, HEX = 00

7	6	5	4	3	2	1	0
BYTE0 [7:0]							
R/W	R/W	R/W	R/W	R/W	R/W	R/W	R/W

LEGEND: R/W = Read/Write; R = Read only; -n = value after reset.

Table 30. User EEPROM, BYTE0 Field Descriptions

BIT	FIELD	TYPE	RESET	DESCRIPTION
7:0	BYTE0	R/W	00000000	USER BYTE 0

7.5.20 User EEPROM, BYTE1

Figure 35. User EEPROM, BYTE1, Address = 21h, HEX = 00

7	6	5	4	3	2	1	0
BYTE1 [15:8]							
R/W	R/W	R/W	R/W	R/W	R/W	R/W	R/W

LEGEND: R/W = Read/Write; R = Read only; -n = value after reset.

Table 31. User EEPROM, BYTE1 Field Descriptions

BIT	FIELD	TYPE	RESET	DESCRIPTION
15:8	BYTE1	R/W	00000000	USER BYTE 1

7.5.21 User EEPROM, BYTE2

Figure 36. User EEPROM, BYTE2, Address = 22h, HEX = 00

7	6	5	4	3	2	1	0
BYTE2 [23:16]							
R/W	R/W	R/W	R/W	R/W	R/W	R/W	R/W

LEGEND: R/W = Read/Write; R = Read only; -n = value after reset.

Table 32. User EEPROM, BYTE2 Field Descriptions

BIT	FIELD	TYPE	RESET	DESCRIPTION
23:16	BYTE2	R/W	00000000	USER BYTE 2

7.5.22 User EEPROM, BYTE3

Figure 37. User EEPROM, BYTE3, Address = 23h, HEX = 00

7	6	5	4	3	2	1	0
BYTE3 [31:24]							
R/W	R/W	R/W	R/W	R/W	R/W	R/W	R/W

LEGEND: R/W = Read/Write; R = Read only; -n = value after reset.

Table 33. User EEPROM, BYTE3 Field Descriptions

BIT	FIELD	TYPE	RESET	DESCRIPTION
31:24	BYTE3	R/W	00000000	USER BYTE 3

7.5.23 User EEPROM, BYTE4
Figure 38. User EEPROM, BYTE4, Address = 24h, HEX = 00

7	6	5	4	3	2	1	0
BYTE4 [39:32]							
R/W	R/W	R/W	R/W	R/W	R/W	R/W	R/W

LEGEND: R/W = Read/Write; R = Read only; -n = value after reset.

Table 34. User EEPROM, BYTE4 Field Descriptions

BIT	FIELD	TYPE	RESET	DESCRIPTION
39:32	BYTE4	R/W	00000000	USER BYTE 4

7.5.24 User EEPROM, BYTE5
Figure 39. User EEPROM, BYTE5, Address = 25h, HEX = 00

7	6	5	4	3	2	1	0
BYTE5 [47:40]							
R/W	R/W	R/W	R/W	R/W	R/W	R/W	R/W

LEGEND: R/W = Read/Write; R = Read only; -n = value after reset.

Table 35. User EEPROM, BYTE5 Field Descriptions

BIT	FIELD	TYPE	RESET	DESCRIPTION
47:40	BYTE5	R/W	00000000	USER BYTE 5

7.5.25 User EEPROM, BYTE6
Figure 40. User EEPROM, BYTE6, Address = 26h, HEX = 00

7	6	5	4	3	2	1	0
BYTE6 [55:48]							
R/W	R/W	R/W	R/W	R/W	R/W	R/W	R/W

LEGEND: R/W = Read/Write; R = Read only; -n = value after reset.

Table 36. User EEPROM, BYTE6 Field Descriptions

BIT	FIELD	TYPE	RESET	DESCRIPTION
55:48	BYTE6	R/W	00000000	USER BYTE 6

7.5.26 User EEPROM, BYTE7
Figure 41. User EEPROM, BYTE7, Address = 27h, HEX = 00

7	6	5	4	3	2	1	0
BYTE7 [63:56]							
R	R	R	R	R	R	R	R

LEGEND: R/W = Read/Write; R = Read only; -n = value after reset.

Table 37. User EEPROM, BYTE7 Field Descriptions

BIT	FIELD	TYPE	RESET	DESCRIPTION
63:56	BYTE7	R	00000000	USER BYTE 7

8 Application and Implementation

NOTE

Information in the following applications sections is not part of the TI component specification, and TI does not warrant its accuracy or completeness. TI's customers are responsible for determining suitability of components for their purposes. Customers should validate and test their design implementation to confirm system functionality.

8.1 Application Information

A DLPC343x controller can be used with a DLP2010 (0.2 WVGA) DMD or DLP3010 (0.3 720p) DMD to provide a compact, reliable, high-efficiency display solution for many different video display applications. The DMDs are spatial light modulators which reflect incoming light from an illumination source to one of two directions with the primary direction being into collection optics within a projection lens. The projection lens sends the light to the destination needed for the application. Each application is derived primarily from the optical architecture of the system and the format of the pixel data being input into the DLPC343x.

In display applications using the DLP2010 DMD or DLP3010 DMD, the DLPA2000 provides all needed analog functions including the analog power supplies and the RGB LED driver to provide a robust and efficient display solution. Display applications of interest include pico-projectors embedded in display devices like smart phones, tablets, cameras, and camcorders. Other applications include wearable (near-eye) displays, battery-powered mobile accessories, interactive displays, low latency gaming displays, and digital signage.

Alternately, a DLPC150 controller can be used with a DLP2010 or DLP2010NIR DMD. Applications of interest when using the DLPC150 controller include machine vision systems, spectrometers, skin analysis, medical systems, material identification, chemical sensing, infrared projection, and compressive sensing. In a spectroscopy application the DLPC150 controller and DLP2010NIR DMD are often combined with a single element detector to replace expensive InGaAs array-based detector designs. In this application the DMD acts as a wavelength selector reflecting specific wavelengths of light into the single point detector.

8.2 Typical Projector Application

A common application when using DLPA2000 with DLP2010 DMD and DLPC3430 controller is for creating a pico-projector embedded in a handheld product. For example, a pico-projector may be embedded in a smart phone, a tablet, a camera, or camcorder. The DLPC3430 in the pico-projector embedded module typically receives images from a host processor within the product as shown in Figure 42. DLPA2000 provides power supply sequencing and controls the LED currents as required by the application.

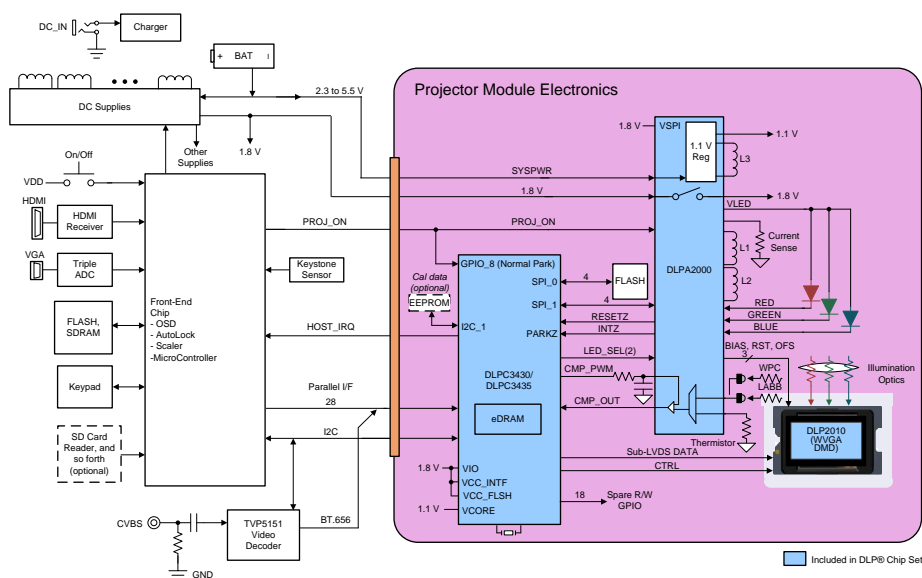

Figure 42. Typical Embedded Setup Using DLPA2000

Typical Projector Application (continued)

8.2.1 Design Requirements

A pico-projector is created by using a DLP chipset comprised of DLP2010 (0.2 WVGA) DMD, DLPC3430, or DLPC3435 controller and DLPA2000 PMIC/LED driver. The DLPC3430 or DLPC3435 does the digital image processing, the DLPA2000 provides the needed analog functions for the projector, and DMD is the display device for producing the projected image.

In addition to the three DLP chips in the chipset, other chips may be needed. At a minimum, a flash part is needed to store the software and firmware to control the DLPC3430 or DLPC3435.

The illumination light that is applied to the DMD is typically from red, green, and blue LEDs. These are often contained in three separate packages, but sometimes more than one color of LED die may be in the same package to reduce the overall size of the pico-projector.

When connecting the DLPC3430 or DLPC3435 to the host processing to receive images, a parallel interface is used. While using the parallel interface, I²C should be connected to the host processor for sending commands to the DLPC3430 or DLPC3435.

The only power supplies needed external to the projector are the battery (SYSPWR) and a regulated 1.8-V supply. The entire pico-projector can be turned on and off by using a single signal called PROJ_ON. When PROJ_ON is high, the projector turns on and begins displaying images. When PROJ_ON is set low, the projector turns off and draws just microamps of current on SYSPWR. When PROJ_ON is set low, the 1.8-V supply can continue to be left at 1.8 V and used by other non-projector sections of the product. If PROJ_ON is low, the DLPA2000 will not draw current on the 1.8-V supply.

8.2.2 Detailed Design Procedure

For connecting together the DLP2010, DLPC3430 or DLPC3435, and DLPA2000, see the reference design schematic. When a circuit board layout is created from this schematic, a very small circuit board is possible. An example small board layout is included in the reference design database. Layout guidelines should be followed to achieve a reliable projector.

The optical engine that has the LED packages and the DMD mounted to it is typically supplied by an optical OEM who specializes in designing optics for DLP projectors.

A miniature stepper motor can optionally be added to the optical engine for creating a motorized focus. Direct control and driving of the motor can be done by the DLPA2000, and software commands sent over I²C to the DLPC3430 or DLPC3435 are available to move the motor to the desired position.

Typical Projector Application (continued)

8.2.3 Application Curve

As the LED currents that are driven time-sequentially through the red, green, and blue LEDs are increased, the brightness of the projector increases. This increase is somewhat non-linear, and the curve for typical white screen lumens changes with LED currents is as shown in [Figure 43](#). For the LED currents shown, it is assumed that the same current amplitude is applied to the red, green, and blue LEDs.

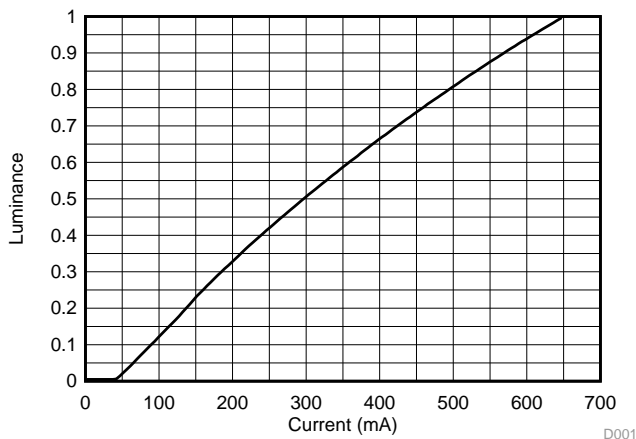

Figure 43. Luminance vs Current

8.3 Typical Mobile Sensing Application

A typical embedded system application using the DLPC150 controller and the DLPC2010NIR is shown in [Figure 44](#). In this configuration, the DLPC150 controller supports a 24-bit parallel RGB input, typical of LCD interfaces, from an external source or processor. The DLPC150 controller processes the digital input image and converts the data into the format needed by the DLP2010NIR. The DLP2010NIR steers light by setting specific micromirrors to the *on* position, directing light to the detector, while unwanted micromirrors are set to the *off* position, directing light away from the detector. The microprocessor sends binary images to the DLP2010NIR to steer specific wavelengths of light into the detector. The microprocessor uses an analog-to-digital converter to sample the signal received by the detector into a digital value. By sequentially selecting different wavelengths of light and capturing the values at the detector, the microprocessor can then plot a spectral response to the light.

Typical Mobile Sensing Application (continued)

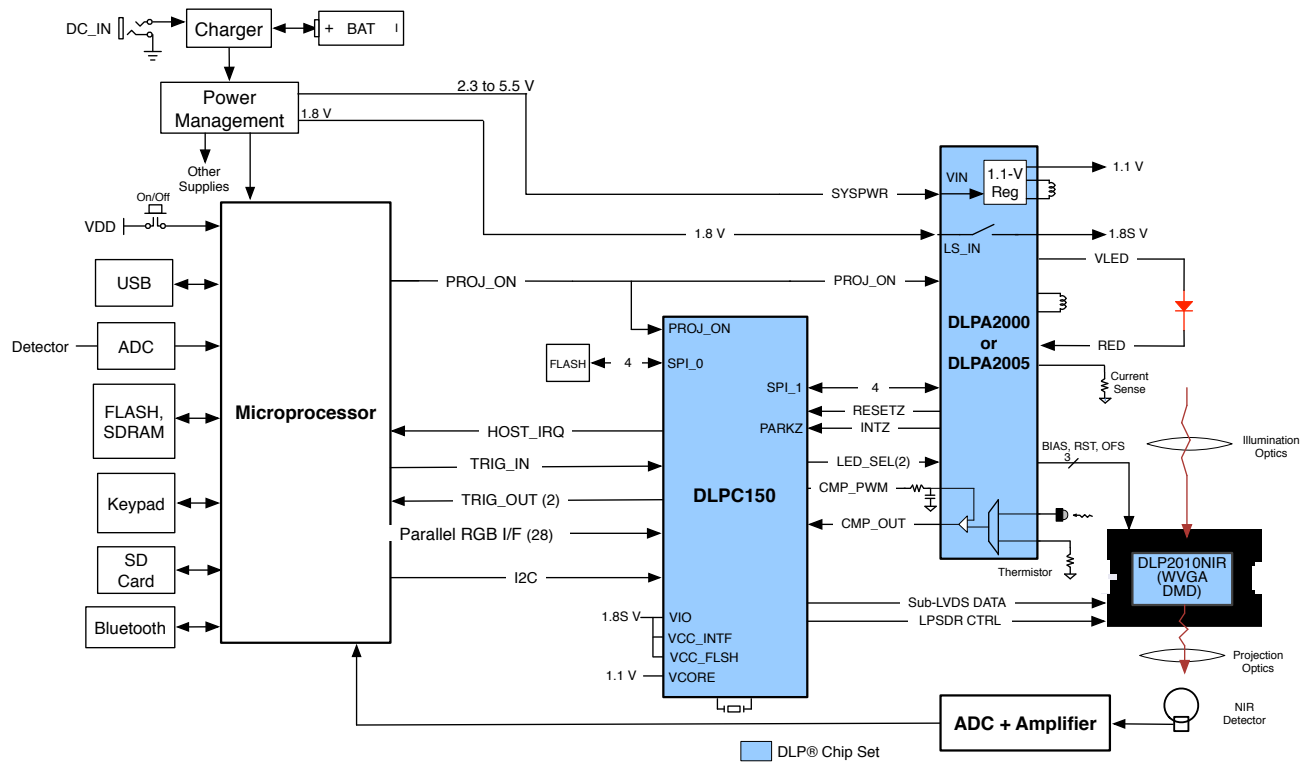

Figure 44. Typical Application Diagram

8.3.1 Design Requirements

All applications using the DLP 0.2-inch WVGA chipset require the:

- DLPC150 controller, and
- DLPA2000 PMIC, and
- DLP2010 or DLP2010NIR DMD

components for operation. The system also requires an external parallel flash memory device loaded with the DLPC150 configuration and support firmware. DLPC150 does the digital image processing and formats the data for the DMD. DLPA2000 PMIC provides the needed analog functions for the DLPC150 and DLP2010 or DLP2010NIR. The chipset has several system interfaces and requires some support circuitry. The following interfaces and support circuitry are required:

- DLPC150 system interfaces:
 - Control interface
 - Trigger interface
 - Input data interface
 - Illumination interface
- DLPC150 support circuitry and interfaces:
 - Reference clock
 - PLL
 - Program memory flash interface
- DMD interfaces:
 - DLPC150 to DMD digital data
 - DLPC150 to DMD control interface
 - DLPC150 to DMD micromirror reset control interface

Typical Mobile Sensing Application (continued)

8.3.2 Detailed Design Procedure

8.3.2.1 Dlp150 System Interfaces

The 0.2-inch WVGA chipset supports a 16-bit or 24-bit parallel RGB interface for image data transfers from another device. There are two primary output interfaces: Illumination driver control interface and sync outputs.

8.3.2.1.1 Control Interface

The 0.2-inch WVGA chipset supports I²C commands through the control interface. The control interface allows another master processor to send commands to the DLPC150 controller to query system status or perform realtime operations, such as LED driver current settings.

8.3.3 Application Curve

In a reflective spectroscopy application, a broadband light source illuminates a sample and the reflected light spectrum is dispersed onto the DLP2010NIR. A microprocessor in conjunction with the DLPC150 controls individual DLP2010NIR micromirrors to reflect specific wavelengths of light to a single point detector. The microprocessor uses an analog-to-digital converter to sample the signal received by the detector into a digital value. By sequentially selecting different wavelengths of light and capturing the values at the detector, the microprocessor can then plot a spectral response to the light. This systems allows the measurement of the collected light and derive the wavelengths absorbed by the sample. This process leads to the absorption spectrum shown in [Figure 45](#).

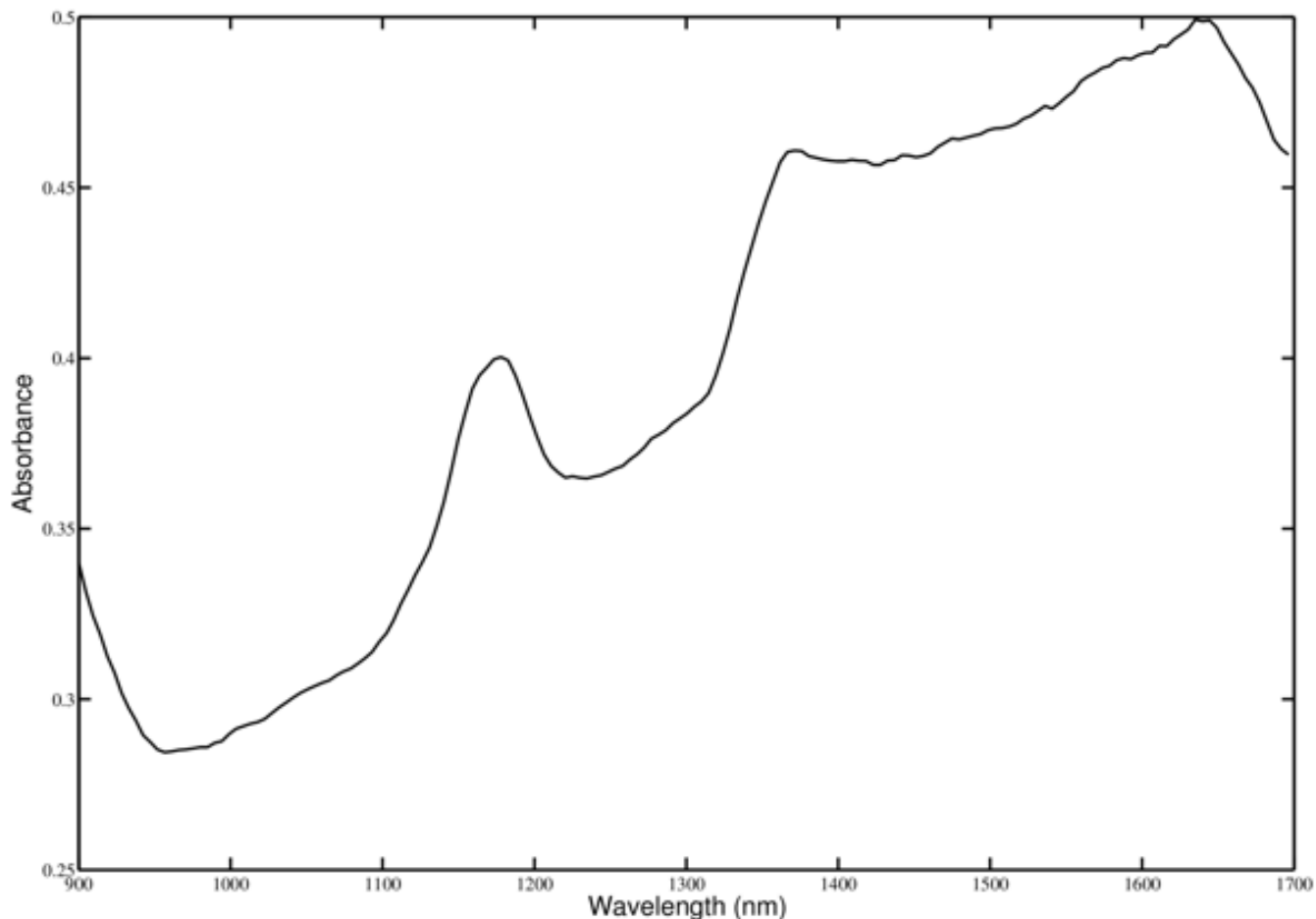

Figure 45. Sample DLPC150 Based Spectrometer Output

9 Power Supply Recommendations

The DLPA2000 is designed to operate from a 2.3-V to 6-V input voltage supply or battery. To avoid insufficient supply current due to line drop, ringing due to trace inductance at the V_{IN} terminal, or supply peak current limitations, additional bulk capacitance may be required. In the case ringing that is caused by the interaction with the ceramic input capacitors, an electrolytic or tantalum type capacitor may be needed for damping. The amount of bulk capacitance required should be evaluated such that the input voltage can remain in specification long enough for a proper fast shutdown to occur for the V_{OFS} , V_{RST} , and V_{BIAS} supplies. The shutdown begins when the input voltage drops below the programmable UVLO threshold such as when the external power supply or battery supply is suddenly removed from the system.

10 Layout

10.1 Layout Guidelines

As for all chips with switching power supplies, the layout is an important step in the design, especially in the case of high peak currents and high switching frequencies. If the layout is not carefully done, the regulators could show stability problems as well as EMI problems. Therefore, use wide and short traces for the main current paths and for the power ground tracks. Input capacitors, output capacitors, and inductors should be placed as close as possible to the IC.

[Figure 46](#) shows an example layout that has critical parts placed as close as possible to the pins they are connected to. Here are recommendations for the following components:

- R1 is R_{LIM} and is connected via a wide trace and as short as possible to the DLPA2000 and the ground.
- L1 is the big inductor for the V_{LED} that is connected via two wide traces to the pins.
- C3/C4 are the decoupling capacitors for the V_{LED} and they are as close as possible placed to the part and directly connected to ground.
- L3/C20 are components used for the V_{CORE} BUCK. L3 is placed close to the pin and connected with a wide trace to the part. C20 is placed directly beside the inductor and connected to the PGND pin.
- L2 This inductor is part of the DMD reset regulators and is also placed as close as possible to the DLPA2000 using wide PCB traces.

10.2 Layout Example

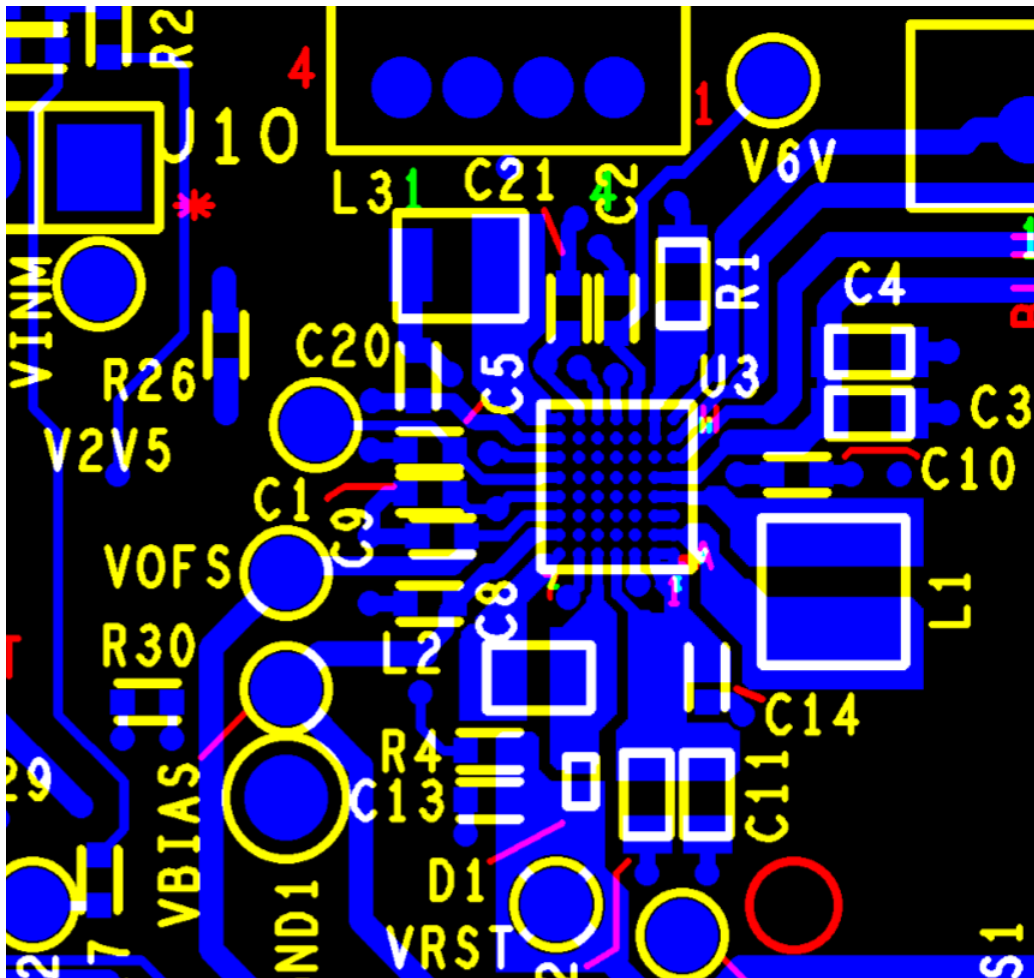

Figure 46. Example Layout of DLPA2000

11 Device and Documentation Support

11.1 Device Support

11.1.1 Device Nomenclature

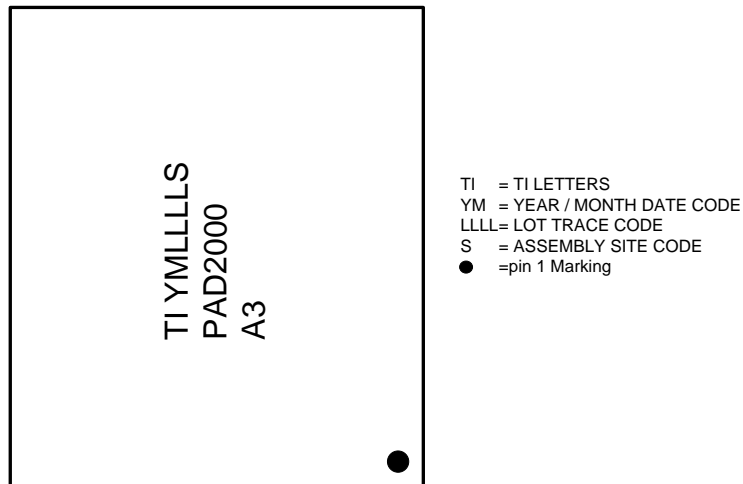

Figure 47. DLPA2000 Package Marking(Top View)

11.2 Related Links

The table below lists quick access links. Categories include technical documents, support and community resources, tools and software, and quick access to sample or buy.

Table 38. Related Links

PARTS	PRODUCT FOLDER	SAMPLE & BUY	TECHNICAL DOCUMENTS	TOOLS & SOFTWARE	SUPPORT & COMMUNITY
DLPA2000	Click here	Click here	Click here	Click here	Click here
DLPC3430	Click here	Click here	Click here	Click here	Click here
DLPC3435	Click here	Click here	Click here	Click here	Click here
DLP2010	Click here	Click here	Click here	Click here	Click here

11.3 Community Resources

The following links connect to TI community resources. Linked contents are provided "AS IS" by the respective contributors. They do not constitute TI specifications and do not necessarily reflect TI's views; see TI's [Terms of Use](#).

TI E2E™ Online Community *TI's Engineer-to-Engineer (E2E) Community*. Created to foster collaboration among engineers. At e2e.ti.com, you can ask questions, share knowledge, explore ideas and help solve problems with fellow engineers.

Design Support *TI's Design Support* Quickly find helpful E2E forums along with design support tools and contact information for technical support.

11.4 Trademarks

DLP, E2E are trademarks of Texas Instruments.
All other trademarks are the property of their respective owners.

11.5 Electrostatic Discharge Caution



These devices have limited built-in ESD protection. The leads should be shorted together or the device placed in conductive foam during storage or handling to prevent electrostatic damage to the MOS gates.

11.6 Glossary

[SLYZ022](#) — *TI Glossary*.

This glossary lists and explains terms, acronyms, and definitions.

12 Mechanical, Packaging, and Orderable Information

The following pages include mechanical, packaging, and orderable information. This information is the most current data available for the designated devices. This data is subject to change without notice and revision of this document. For browser-based versions of this data sheet, refer to the left-hand navigation.

- Insertion of device –The device is located such as symbolization in upper side and lead pins in lower side.
- Cover tape – The cover tape does not cover the index hole and does not shift to outside from carrier tape.
- Tape Structure –The carrier tape is made of plastic and the structure is shown in above schematic. The device is put on embossed area of carrier tape, and covered by cover tape made of plastic.
- ESD Countermeasure Plastic – material used in both carrier tape and cover tape are static dissipative.
- Material – Polycarbonate, Polystyrene or and approved equivalent (Static Dissipative / Antistatic).
- Packing method – The reel is packed into Moisture Barrier bag and fastened by heat-sealing after fixed the end of leader tape by tape. The QFN device packing includes desiccant, humidity indicator.
- Reel Box – Each Moisture Barrier bag is packed into reel box.

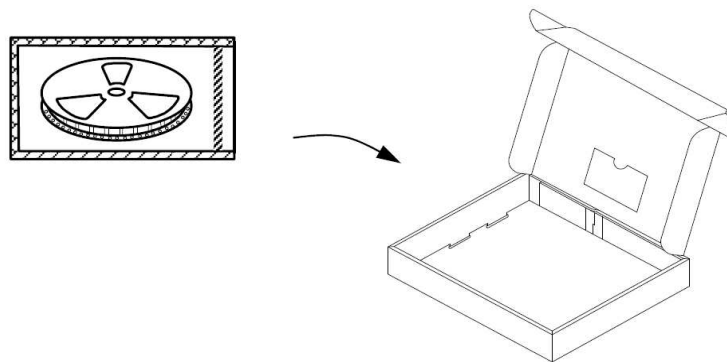

Reel box (carton)

- Reel Box Material – Corrugated Fiberboard
- Shipping Box –The filler such as cushion is added if space exists inside. The size of shipping box will be changed per packing quantity of reel box.

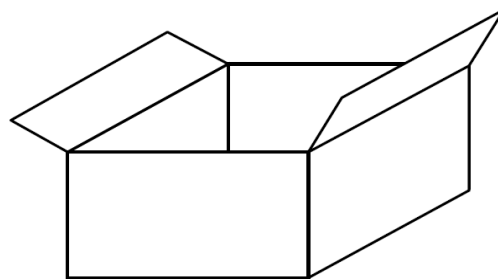

Shipping box (carton)

PACKAGING INFORMATION

Orderable Device	Status (1)	Package Type	Package Drawing	Pins	Package Qty	Eco Plan (2)	Lead/Ball Finish (6)	MSL Peak Temp (3)	Op Temp (°C)	Device Marking (4/5)	Samples
DLPA2000DYFFR	ACTIVE	DSBGA	YFF	56	3000	Green (RoHS & no Sb/Br)	SNAGCU	Level-1-260C-UNLIM		PAD2000 A3	Samples

(1) The marketing status values are defined as follows:

ACTIVE: Product device recommended for new designs.

LIFEBUY: TI has announced that the device will be discontinued, and a lifetime-buy period is in effect.

NRND: Not recommended for new designs. Device is in production to support existing customers, but TI does not recommend using this part in a new design.

PREVIEW: Device has been announced but is not in production. Samples may or may not be available.

OBSOLETE: TI has discontinued the production of the device.

(2) **RoHS:** TI defines "RoHS" to mean semiconductor products that are compliant with the current EU RoHS requirements for all 10 RoHS substances, including the requirement that RoHS substance do not exceed 0.1% by weight in homogeneous materials. Where designed to be soldered at high temperatures, "RoHS" products are suitable for use in specified lead-free processes. TI may reference these types of products as "Pb-Free".

RoHS Exempt: TI defines "RoHS Exempt" to mean products that contain lead but are compliant with EU RoHS pursuant to a specific EU RoHS exemption.

Green: TI defines "Green" to mean the content of Chlorine (Cl) and Bromine (Br) based flame retardants meet JS709B low halogen requirements of <=1000ppm threshold. Antimony trioxide based flame retardants must also meet the <=1000ppm threshold requirement.

(3) MSL, Peak Temp. - The Moisture Sensitivity Level rating according to the JEDEC industry standard classifications, and peak solder temperature.

(4) There may be additional marking, which relates to the logo, the lot trace code information, or the environmental category on the device.

(5) Multiple Device Markings will be inside parentheses. Only one Device Marking contained in parentheses and separated by a "~" will appear on a device. If a line is indented then it is a continuation of the previous line and the two combined represent the entire Device Marking for that device.

(6) Lead/Ball Finish - Orderable Devices may have multiple material finish options. Finish options are separated by a vertical ruled line. Lead/Ball Finish values may wrap to two lines if the finish value exceeds the maximum column width.

Important Information and Disclaimer:The information provided on this page represents TI's knowledge and belief as of the date that it is provided. TI bases its knowledge and belief on information provided by third parties, and makes no representation or warranty as to the accuracy of such information. Efforts are underway to better integrate information from third parties. TI has taken and continues to take reasonable steps to provide representative and accurate information but may not have conducted destructive testing or chemical analysis on incoming materials and chemicals. TI and TI suppliers consider certain information to be proprietary, and thus CAS numbers and other limited information may not be available for release.

In no event shall TI's liability arising out of such information exceed the total purchase price of the TI part(s) at issue in this document sold by TI to Customer on an annual basis.

TAPE AND REEL INFORMATION



QUADRANT ASSIGNMENTS FOR PIN 1 ORIENTATION IN TAPE



*All dimensions are nominal

Device	Package Type	Package Drawing	Pins	SPQ	Reel Diameter (mm)	Reel Width W1 (mm)	A0 (mm)	B0 (mm)	K0 (mm)	P1 (mm)	W (mm)	Pin1 Quadrant
DLPA2000DYFFR	DSBGA	YFF	56	3000	330.0	12.4	3.4	3.75	0.82	8.0	12.0	Q1

TAPE AND REEL BOX DIMENSIONS



*All dimensions are nominal

Device	Package Type	Package Drawing	Pins	SPQ	Length (mm)	Width (mm)	Height (mm)
DLPA2000DYFFR	DSBGA	YFF	56	3000	367.0	367.0	35.0

YFF0056

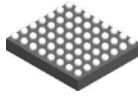

PACKAGE OUTLINE

DSBGA - 0.625 mm max height

DIE SIZE BALL GRID ARRAY

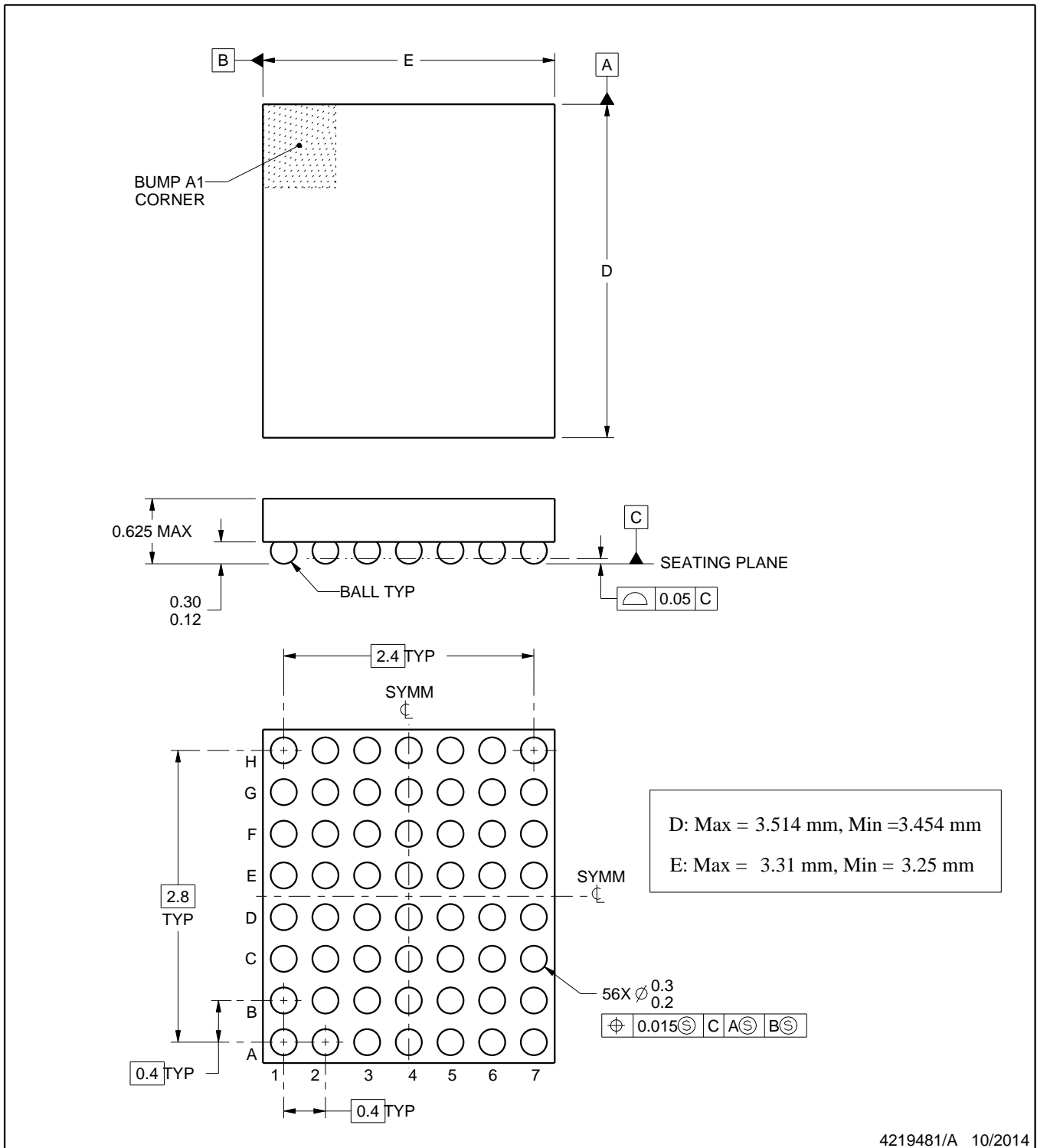

NOTES:

1. All linear dimensions are in millimeters. Any dimensions in parenthesis are for reference only. Dimensioning and tolerancing per ASME Y14.5M.
2. This drawing is subject to change without notice.

EXAMPLE BOARD LAYOUT

YFF0056

DSBGA - 0.625 mm max height

DIE SIZE BALL GRID ARRAY

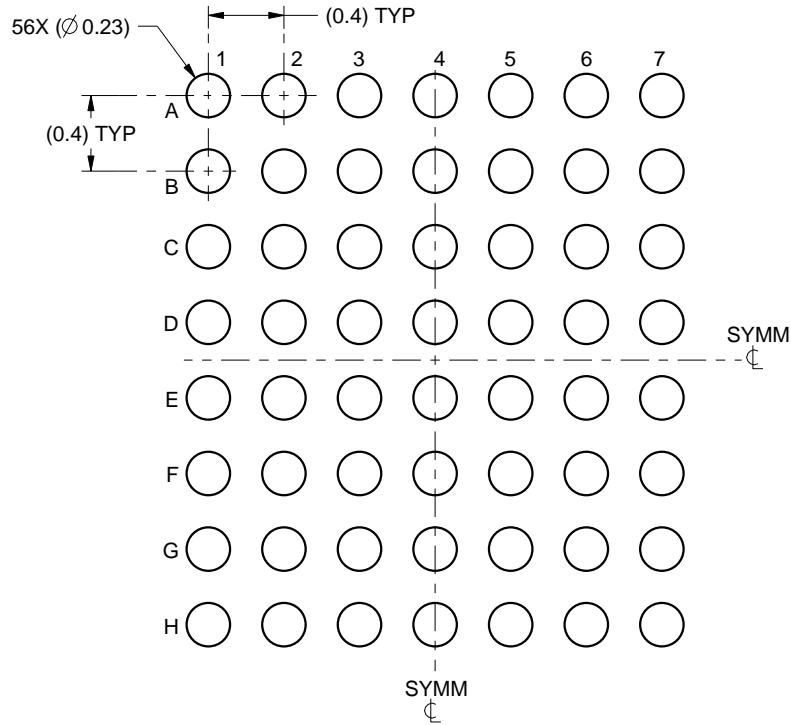

LAND PATTERN EXAMPLE
SCALE:25X

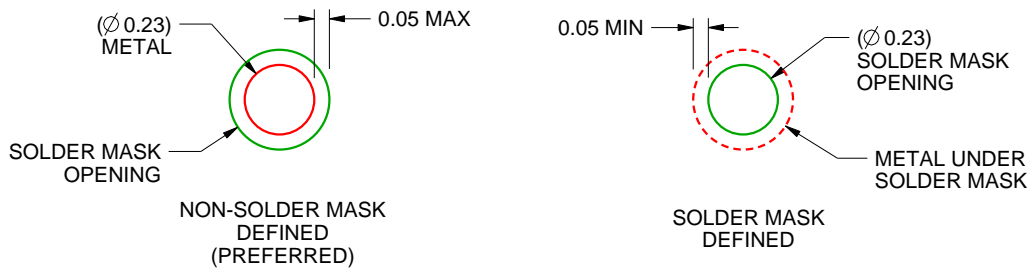

SOLDER MASK DETAILS
NOT TO SCALE

4219481/A 10/2014

NOTES: (continued)

- Final dimensions may vary due to manufacturing tolerance considerations and also routing constraints. For more information, see Texas Instruments literature number SBVA017 (www.ti.com/lit/sbva017).

EXAMPLE STENCIL DESIGN

YFF0056

DSBGA - 0.625 mm max height

DIE SIZE BALL GRID ARRAY

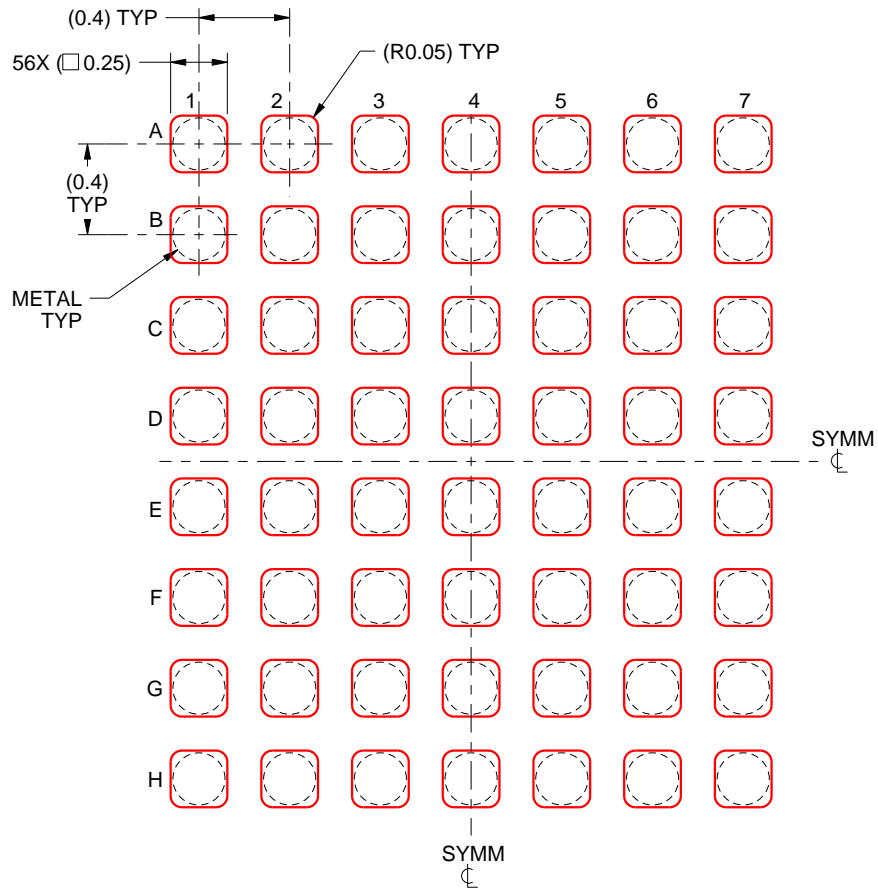

SOLDER PASTE EXAMPLE
BASED ON 0.1 mm THICK STENCIL
SCALE:30X

4219481/A 10/2014

NOTES: (continued)

4. Laser cutting apertures with trapezoidal walls and rounded corners may offer better paste release.

IMPORTANT NOTICE

Texas Instruments Incorporated (TI) reserves the right to make corrections, enhancements, improvements and other changes to its semiconductor products and services per JESD46, latest issue, and to discontinue any product or service per JESD48, latest issue. Buyers should obtain the latest relevant information before placing orders and should verify that such information is current and complete.

TI's published terms of sale for semiconductor products (<http://www.ti.com/sc/docs/stdterms.htm>) apply to the sale of packaged integrated circuit products that TI has qualified and released to market. Additional terms may apply to the use or sale of other types of TI products and services.

Reproduction of significant portions of TI information in TI data sheets is permissible only if reproduction is without alteration and is accompanied by all associated warranties, conditions, limitations, and notices. TI is not responsible or liable for such reproduced documentation. Information of third parties may be subject to additional restrictions. Resale of TI products or services with statements different from or beyond the parameters stated by TI for that product or service voids all express and any implied warranties for the associated TI product or service and is an unfair and deceptive business practice. TI is not responsible or liable for any such statements.

Buyers and others who are developing systems that incorporate TI products (collectively, "Designers") understand and agree that Designers remain responsible for using their independent analysis, evaluation and judgment in designing their applications and that Designers have full and exclusive responsibility to assure the safety of Designers' applications and compliance of their applications (and of all TI products used in or for Designers' applications) with all applicable regulations, laws and other applicable requirements. Designer represents that, with respect to their applications, Designer has all the necessary expertise to create and implement safeguards that (1) anticipate dangerous consequences of failures, (2) monitor failures and their consequences, and (3) lessen the likelihood of failures that might cause harm and take appropriate actions. Designer agrees that prior to using or distributing any applications that include TI products, Designer will thoroughly test such applications and the functionality of such TI products as used in such applications.

TI's provision of technical, application or other design advice, quality characterization, reliability data or other services or information, including, but not limited to, reference designs and materials relating to evaluation modules, (collectively, "TI Resources") are intended to assist designers who are developing applications that incorporate TI products; by downloading, accessing or using TI Resources in any way, Designer (individually or, if Designer is acting on behalf of a company, Designer's company) agrees to use any particular TI Resource solely for this purpose and subject to the terms of this Notice.

TI's provision of TI Resources does not expand or otherwise alter TI's applicable published warranties or warranty disclaimers for TI products, and no additional obligations or liabilities arise from TI providing such TI Resources. TI reserves the right to make corrections, enhancements, improvements and other changes to its TI Resources. TI has not conducted any testing other than that specifically described in the published documentation for a particular TI Resource.

Designer is authorized to use, copy and modify any individual TI Resource only in connection with the development of applications that include the TI product(s) identified in such TI Resource. NO OTHER LICENSE, EXPRESS OR IMPLIED, BY ESTOPPEL OR OTHERWISE TO ANY OTHER TI INTELLECTUAL PROPERTY RIGHT, AND NO LICENSE TO ANY TECHNOLOGY OR INTELLECTUAL PROPERTY RIGHT OF TI OR ANY THIRD PARTY IS GRANTED HEREIN, including but not limited to any patent right, copyright, mask work right, or other intellectual property right relating to any combination, machine, or process in which TI products or services are used. Information regarding or referencing third-party products or services does not constitute a license to use such products or services, or a warranty or endorsement thereof. Use of TI Resources may require a license from a third party under the patents or other intellectual property of the third party, or a license from TI under the patents or other intellectual property of TI.

TI RESOURCES ARE PROVIDED "AS IS" AND WITH ALL FAULTS. TI DISCLAIMS ALL OTHER WARRANTIES OR REPRESENTATIONS, EXPRESS OR IMPLIED, REGARDING RESOURCES OR USE THEREOF, INCLUDING BUT NOT LIMITED TO ACCURACY OR COMPLETENESS, TITLE, ANY EPIDEMIC FAILURE WARRANTY AND ANY IMPLIED WARRANTIES OF MERCHANTABILITY, FITNESS FOR A PARTICULAR PURPOSE, AND NON-INFRINGEMENT OF ANY THIRD PARTY INTELLECTUAL PROPERTY RIGHTS. TI SHALL NOT BE LIABLE FOR AND SHALL NOT DEFEND OR INDEMNIFY DESIGNER AGAINST ANY CLAIM, INCLUDING BUT NOT LIMITED TO ANY INFRINGEMENT CLAIM THAT RELATES TO OR IS BASED ON ANY COMBINATION OF PRODUCTS EVEN IF DESCRIBED IN TI RESOURCES OR OTHERWISE. IN NO EVENT SHALL TI BE LIABLE FOR ANY ACTUAL, DIRECT, SPECIAL, COLLATERAL, INDIRECT, PUNITIVE, INCIDENTAL, CONSEQUENTIAL OR EXEMPLARY DAMAGES IN CONNECTION WITH OR ARISING OUT OF TI RESOURCES OR USE THEREOF, AND REGARDLESS OF WHETHER TI HAS BEEN ADVISED OF THE POSSIBILITY OF SUCH DAMAGES.

Unless TI has explicitly designated an individual product as meeting the requirements of a particular industry standard (e.g., ISO/TS 16949 and ISO 26262), TI is not responsible for any failure to meet such industry standard requirements.

Where TI specifically promotes products as facilitating functional safety or as compliant with industry functional safety standards, such products are intended to help enable customers to design and create their own applications that meet applicable functional safety standards and requirements. Using products in an application does not by itself establish any safety features in the application. Designers must ensure compliance with safety-related requirements and standards applicable to their applications. Designer may not use any TI products in life-critical medical equipment unless authorized officers of the parties have executed a special contract specifically governing such use. Life-critical medical equipment is medical equipment where failure of such equipment would cause serious bodily injury or death (e.g., life support, pacemakers, defibrillators, heart pumps, neurostimulators, and implantables). Such equipment includes, without limitation, all medical devices identified by the U.S. Food and Drug Administration as Class III devices and equivalent classifications outside the U.S.

TI may expressly designate certain products as completing a particular qualification (e.g., Q100, Military Grade, or Enhanced Product). Designers agree that it has the necessary expertise to select the product with the appropriate qualification designation for their applications and that proper product selection is at Designers' own risk. Designers are solely responsible for compliance with all legal and regulatory requirements in connection with such selection.

Designer will fully indemnify TI and its representatives against any damages, costs, losses, and/or liabilities arising out of Designer's non-compliance with the terms and provisions of this Notice.

Looking for pricing, stock, or lifecycle information?

Click below to explore more details on WIN SOURCE:

 [View DLPA2000DYFFR on WIN SOURCE](#)

 [Texas Instruments](#) Information

Optimize Your Supply Chain with WIN SOURCE Solutions

-  Global Sourcing Solution
-  Obsolete Management
-  Cost Control Management
-  Shortage Management
-  Alternative Solution
-  Excess Inventory Management