



**THE DATASHEET OF
UCC3818APW**



UCCx81xA BiCMOS Power Factor Preregulator

1 Features

- Controls Boost Preregulator to Near-Unity Power Factor
- Limits Line Distortion
- World Wide Line Operation
- Overvoltage Protection
- Accurate Power Limiting
- Average Current Mode Control
- Improved Noise Immunity
- Improved Feed-Forward Line Regulation
- Leading Edge Modulation
- 150- μ A Typical Start-Up Current
- Low-Power BiCMOS Operation
- 12-V to 17-V Operation
- Frequency Range of 6 kHz to 220 kHz

2 Applications

- PC Power
- Consumer Electronics
- Lighting
- Industrial Power Supplies
- IEC6100-3-2 Compliant Supplies Less Than 300 W

3 Description

The UCC3817A and the UCC3818A family provides all the functions necessary for active power factor corrected preregulators. The controller achieves near unity power factor by shaping the ac input line current waveform to correspond to that of the ac input line voltage. Average current mode control maintains stable, low distortion sinusoidal line current.

Designed in Texas Instrument's BiCMOS process, the UCC3817A/UCC3818A offers new features such as lower start-up current, lower power dissipation, overvoltage protection, a shunt UVLO detect circuitry, a leading-edge modulation technique to reduce ripple current in the bulk capacitor and an improved, low-offset (± 2 mV) current amplifier to reduce distortion at light load conditions.

Device Information⁽¹⁾

PART NUMBER	PACKAGE	BODY SIZE (NOM)
UCCx81xA	SOIC (16)	4.90 mm x 3.91 mm
	PDIP (16)	19.30 mm x 6.35 mm
	TSSOP (16)	5.00 mm x 4.40 mm

(1) For all available packages, see the orderable addendum at the end of the data sheet.

Block Diagram

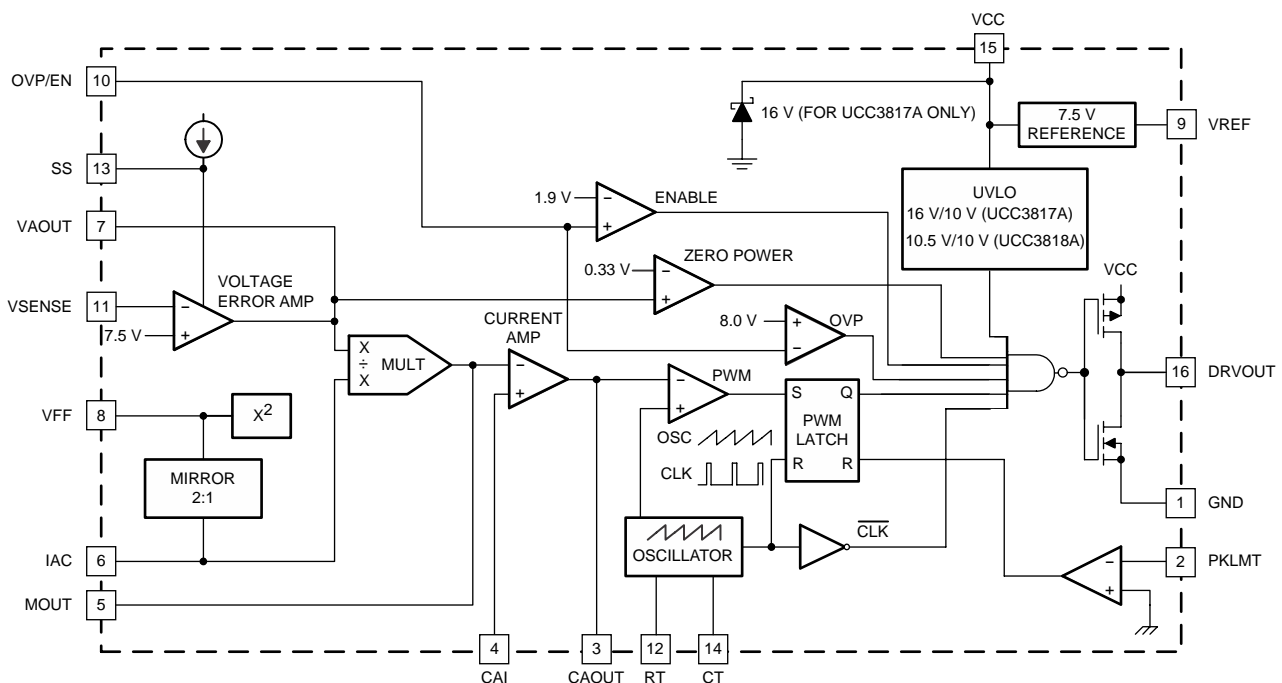

Copyright © 2016, Texas Instruments Incorporated



Table of Contents

1 Features	1	9.4 Device Functional Modes	12
2 Applications	1	10 Application and Implementation	14
3 Description	1	10.1 Application Information	14
4 Revision	2	10.2 Typical Application	15
5 Description (Continued)	3	11 Power Supply Recommendations	25
6 Device Comparison Tables	3	12 Layout	25
7 Pin Configuration and Functions	4	12.1 Layout Guidelines	25
8 Specifications	5	12.2 Layout Example	25
8.1 Absolute Maximum Ratings	5	13 Device and Documentation Support	26
8.2 ESD Ratings	5	13.1 Documentation Support	26
8.3 Recommended Operating Conditions	5	13.2 Related Links	26
8.4 Thermal Information	6	13.3 Receiving Notification of Documentation Updates	26
8.5 Electrical Characteristics	6	13.4 Community Resource	26
8.6 Typical Characteristics	8	13.5 Trademarks	26
9 Detailed Description	9	13.6 Electrostatic Discharge Caution	26
9.1 Overview	9	13.7 Glossary	26
9.2 Functional Block Diagram	9	14 Mechanical, Packaging, and Orderable Information	27
9.3 Feature Description	9		

4 Revision

NOTE: Page numbers for previous revisions may differ from page numbers in the current version.

Changes from Revision C (November 2011) to Revision D	Page
• Added <i>ESD Ratings</i> table, <i>Feature Description</i> section, <i>Device Functional Modes</i> , <i>Application and Implementation</i> section, <i>Power Supply Recommendations</i> section, <i>Layout</i> section, <i>Device and Documentation Support</i> section, and <i>Mechanical, Packaging, and Orderable Information</i> section	1
• Changed the $R_{\theta JA}$ and $R_{\theta JC(top)}$ thermal values for all packages	6
• Combined the <i>Electrical Characteristics</i> tables	6

5 Description (Continued)

The UCC3817A/18A family of PFC Controllers is directly pin for pin compatible with the UCC3817/18 family of devices. Only the output stage of UCC3817A family has been modified to allow use of a smaller external gate drive resistor values. For some power supply designs where an adequately high enough gate drive resistor can not be used, the UCC3817A/18A family offers a more robust output stage at the cost of increasing the internal gate resistances. The gate drive of the UC3817A/18A family however remains strong at ± 1.2 A of peak current capability.

UCC3817A offers an on-chip shunt regulator with low start-up current, suitable for applications utilizing a bootstrap supply. UCC3818A is intended for applications with a fixed supply (VCC). Both devices are available in the 16-pin D, N and PW packages.

6 Device Comparison Tables

Table 1. Available Options

$T_A = T_J$	PACKAGE DEVICES					
	SOIC (D) PACKAGE ⁽¹⁾		PDIP (N) PACKAGE		TSSOP (PW) PACKAGE ⁽¹⁾	
	TURNON THRESHOLD 16 V	TURNON THRESHOLD 10.2 V	TURNON THRESHOLD 16 V	TURNON THRESHOLD 10.2 V	TURNON THRESHOLD 16 V	TURNON THRESHOLD 10.2 V
–40°C to 85°C	UCC2817AD	UCC2818AD	UCC2817AN	UCC2818AN	UCC2817APW	UCC2818APW
0°C to 70°C	UCC3817AD	UCC3818AD	UCC3817AN	UCC3818AN	UCC3817APW	UCC3818APW

- (1) The D and PW packages are available taped and reeled. Add R suffix to the device type (e.g. UCC3817ADR) to order quantities of 2,500 devices per reel (D package) and 2,000 devices per reel (for PW package). Bulk quantities are 40 units (D package) and 90 units (PW package) per tube.

Table 2. Related Products

DEVICE	DESCRIPTION	CONTROL METHOD	TYPICAL POWER LEVEL
UC3854	PFC controller	ACM ⁽¹⁾	200 W to 2 kW+
UC3854A/B	Improved PFC controller	ACM ⁽¹⁾	200 W to 2 kW+
UC3855A/B	High performance soft switching PFC controller	ACM ⁽¹⁾	400 W to 2 kW+
UCC38050/1	Transition mode PFC controller	CRM ⁽²⁾	50 W to 400 W
UCC3819	Tracking boost PFC controller	ACM ⁽¹⁾	75 W to 2 kW+
UCC28510/11/12/13	Advanced PFC+PWM combo controller	ACM ⁽¹⁾	75 W to 1kW+
UCC28514/15/16/17	Advanced PFC+PWM combo controller	ACM ⁽¹⁾	75 W to 1kW+

- (1) Average current mode
(2) Critical conduction mode

7 Pin Configuration and Functions

**D, N, and PW Packages
16-Pin SOIC, PDIP, and TSSOP
Top View**

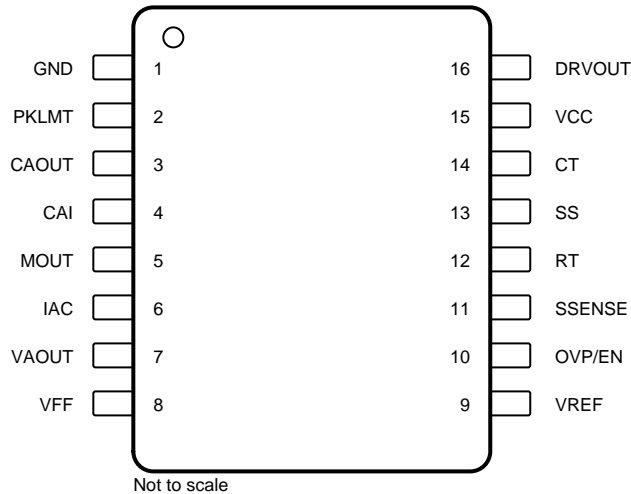

Pin Functions

PIN		I/O	DESCRIPTION
NO.	NAME		
4	CAI	I	Current amplifier noninverting input
3	CAOUT	O	Current amplifier output
14	CT	I	Oscillator timing capacitor
16	DRVOUT	O	Gate drive
1	GND	—	Ground
6	IAC	I	Current proportional to input voltage
5	MOUT	I/O	Multiplier output and current amplifier inverting input
10	OVP/EN	I	Overvoltage/enable
2	PKLMT	I	PFC peak current limit
12	RT	I	Oscillator charging current
13	SS	I	Soft-start
7	VAOUT	O	Voltage amplifier output
15	VCC	I	Positive supply voltage
8	VFF	I	Feed-forward voltage
11	SSSENSE	I	Voltage amplifier inverting input
9	VREF	O	Voltage reference output

8 Specifications

8.1 Absolute Maximum Ratings

over operating free-air temperature range (unless otherwise noted)⁽¹⁾

	MIN	MAX	UNIT
Supply voltage VCC		18	V
Supply current ICC		20	mA
Gate drive current, continuous		0.2	A
Gate drive current		1.2	A
Input voltage, CAI, MOUT, SS		8	V
Input voltage, PKLMT		5	V
Input voltage, VSENSE, OVP/EN		10	V
Input current, RT, IAC, PKLMT		10	mA
Input current, VCC (no switching)		20	mA
Maximum negative voltage, DRVOUT, PKLMT, MOUT	-0.5		V
Power dissipation		1	W
Lead temperature, T _{sol} (soldering, 10 seconds)		300	°C
Power dissipation		1	W
Junction temperature, T _J	-55	150	°C
Storage temperature, T _{stg}	-65	150	°C

- (1) Stresses beyond those listed under *Absolute Maximum Ratings* may cause permanent damage to the device. These are stress ratings only, which do not imply functional operation of the device at these or any other conditions beyond those indicated under *Recommended Operating Conditions*. Exposure to absolute-maximum-rated conditions for extended periods may affect device reliability.

8.2 ESD Ratings

		VALUE	UNIT
V _(ESD)	Electrostatic discharge	Human-body model (HBM), per ANSI/ESDA/JEDEC JS-001 ⁽¹⁾	V
		Charged-device model (CDM), per JEDEC specification JESD22-C101 ⁽²⁾	
		±2000	
		±1500	

- (1) JEDEC document JEP155 states that 500-V HBM allows safe manufacturing with a standard ESD control process.
 (2) JEDEC document JEP157 states that 250-V CDM allows safe manufacturing with a standard ESD control process.

8.3 Recommended Operating Conditions

over operating free-air temperature range (unless otherwise noted)

		MIN	NOM	MAX	UNIT
VCC	Input voltage		12	18	V
VSENSE	Input sense voltage		7.5	10	V
	Input current for oscillator		1.36	10	mA

8.4 Thermal Information

THERMAL METRIC ⁽¹⁾		UCCx81xA			UNIT
		D (SOIC)	N (PDIP)	PW (TSSOP)	
		16 PINS	16 PINS	16 PINS	
R _{θJA}	Junction-to-ambient thermal resistance	73.9	49.3	98.9	°C/W
R _{θJC(top)}	Junction-to-case (top) thermal resistance	33.5	38.9	30.2	°C/W
R _{θJB}	Junction-to-board thermal resistance	31.4	29.4	44.8	°C/W
ψ _{JT}	Junction-to-top characterization parameter	5.8	18.9	1.9	°C/W
ψ _{JB}	Junction-to-board characterization parameter	31.1	29.2	44.1	°C/W

(1) For more information about traditional and new thermal metrics, see the [Semiconductor and IC Package Thermal Metrics](#) application report.

8.5 Electrical Characteristics

T_A = 0°C to 70°C for the UCC3817A and T_A = -40°C to 85°C for the UCC2817A, T_A = T_J, V_{CC} = 12 V, R_T = 22 kΩ, C_T = 270 pF, (unless otherwise noted)

PARAMETER	TEST CONDITIONS	MIN	TYP	MAX	UNIT
SUPPLY CURRENT SECTION					
Supply current, OFF	V _{CC} = (V _{CC} turnon threshold - 0.3 V)		150	300	μA
Supply current, ON	V _{CC} = 12 V, No load on DRVOUT	2	4	6	mA
UVLO SECTION					
V _{CC} turnon threshold (UCCx817)		15.4	16	16.6	V
V _{CC} turnoff threshold (UCCx817)		9.4	9.7		V
UVLO hysteresis (UCCx817)		5.8	6.3		V
Maximum shunt voltage (UCCx817)	I _{VCC} = 10 mA	15.4	17	17.5	V
V _{CC} turnon threshold (UCCx818)		9.7	10.2	10.8	V
V _{CC} turnoff threshold (UCCx818)		9.4	9.7		V
UVLO hysteresis (UCCx818)		0.3	0.5		V
VOLTAGE AMPLIFIER SECTION					
Input voltage	T _A = 0°C to 70°C	7.387	7.5	7.613	V
	T _A = -40°C to 85°C	7.369	7.5	7.631	
V _{SENSE} bias current	V _{SENSE} = V _{REF} , V _{AO} = 2.5 V		50	200	nA
Open-loop gain	V _{AO} = 2 V to 5 V	50	90		dB
High-level output voltage	I _L = -150 μA	5.3	5.5	5.6	V
Low-level output voltage	I _L = 150 μA	0	50	150	mV
OVER VOLTAGE PROTECTION AND ENABLE SECTION					
Over voltage reference		V _{REF} +0.48	V _{REF} +0.50	V _{REF} +0.52	V
Hysteresis		300	500	600	mV
Enable threshold		1.7	1.9	2.1	V
Enable hysteresis		0.1	0.	0.3	V
CURRENT AMPLIFIER SECTION					
Input offset voltage	V _{CM} = 0 V, V _{CAOUT} = 3 V	-3.5	0	2.5	mV
Input bias current	V _{CM} = 0 V, V _{CAOUT} = 3 V		-50	-100	nA
Input offset current	V _{CM} = 0 V, V _{CAOUT} = 3 V		25	100	nA
Open loop gain	V _{CM} = 0 V, V _{CAOUT} = 2 V to 5 V	90			dB
Common-mode output voltage	V _{CM} = 0 V to 1.5 V, V _{CAOUT} = 3 V	60	80		dB
High-level output voltage	I _L = -120 mA	5.6	6.5	6.8	VV
Low-level output voltage	I _L = 1 mA	0.1	0.2	0.5	MHz
Gain bandwidth product	See ⁽¹⁾		2.5		

(1) Ensured by design, not production tested.

Electrical Characteristics (continued)

$T_A = 0^\circ\text{C}$ to 70°C for the UCC3817A and $T_A = -40^\circ\text{C}$ to 85°C for the UCC2817A, $T_A = T_J$, $V_{CC} = 12\text{ V}$, $R_T = 22\text{ k}\Omega$, $C_T = 270\text{ pF}$, (unless otherwise noted)

PARAMETER	TEST CONDITIONS	MIN	TYP	MAX	UNIT
VOLTAGE REFERENCE SECTION					
Input voltage	$T_A = 0^\circ\text{C}$ to 70°C	7.387	7.5	7.613	V
	$T_A = -40^\circ\text{C}$ to 85°C	7.369	7.5	7.631	
Load regulation	$I_{REF} = 1\text{ mA}$ to 2 mA	0		10	mV
Line regulation	$V_{CC} = 10.8$ to $15\text{ V}^{(2)}$	0		10	mV
Short-circuit current	$V_{REF} = 0\text{ V}$	-20	-25	-50	mA
OSCILLATOR SECTION					
Initial accuracy	$T_A = 25^\circ\text{C}$	85	100	115	kHz
Voltage stability	$V_{CC} = 10.8$ to 15 V	-1%		1%	
Total variation	Line, temp	80		120	kHz
Ramp peak voltage		4.5	5	5.5	V
Ramp amplitude voltage (peak to peak)		3.5	4	4.5	V
PEAK CURRENT LIMIT SECTION					
PKLMT reference voltage		-15		15	mV
PKLMT propagation delay		150	350	500	ns
MULTIPLIER SECTION					
I_{MOUT} , high line, low power output current, (0°C to 85°C)	$I_{AC} = 500\text{ }\mu\text{A}$, $V_{FF} = 4.7\text{ V}$, $VAOUT = 1.25\text{ V}$	0	-6	-20	μA
I_{MOUT} , high line, low power output current, (-40°C to 85°C)	$I_{AC} = 500\text{ }\mu\text{A}$, $V_{FF} = 4.7\text{ V}$, $VAOUT = 1.25\text{ V}$	0	-6	-23	
I_{MOUT} , high line, low power output current	$I_{AC} = 500\text{ }\mu\text{A}$, $V_{FF} = 4.7\text{ V}$, $VAOUT = 5\text{ V}$	-70	-90	-105	
I_{MOUT} , low line, low power output current	$I_{AC} = 150\text{ }\mu\text{A}$, $V_{FF} = 1.4\text{ V}$, $VAOUT = 1.25\text{ V}$	-10	-19	-50	
I_{MOUT} , low line, high power output current	$I_{AC} = 150\text{ }\mu\text{A}$, $V_{FF} = 1.4\text{ V}$, $VAOUT = 5\text{ V}$	-268	-300	-345	
I_{MOUT} , IAC limited output current	$I_{AC} = 150\text{ }\mu\text{A}$, $V_{FF} = 1.3\text{ V}$, $VAOUT = 5\text{ V}$	-250	-300	-400	
Gain constant (K)	$I_{AC} = 150\text{ }\mu\text{A}$, $V_{FF} = 1.3\text{ V}$, $VAOUT = 2.5\text{ V}$	0.5	1	1.5	1/V
I_{MOUT} , zero current	$I_{AC} = 150\text{ }\mu\text{A}$, $V_{FF} = 1.4\text{ V}$, $VAOUT = 0.25\text{ V}$		0	-2	μA
	$I_{AC} = 500\text{ }\mu\text{A}$, $V_{FF} = 4.7\text{ V}$, $VAOUT = 0.25\text{ V}$		0	-2	
I_{MOUT} , zero current, (0°C to 85°C)	$I_{AC} = 500\text{ }\mu\text{A}$, $V_{FF} = 4.7\text{ V}$, $VAOUT = 0.5\text{ V}$		0	-3	μA
I_{MOUT} , zero current, (-40°C to 85°C)	$I_{AC} = 500\text{ }\mu\text{A}$, $V_{FF} = 4.7\text{ V}$, $VAOUT = 0.5\text{ V}$		0	-3.5	μA
Power limit ($I_{MOUT} \times V_{FF}$)	$I_{AC} = 150\text{ }\mu\text{A}$, $V_{FF} = 1.4\text{ V}$, $VAOUT = 5\text{ V}$	-375	-420	-485	μW
FEED-FORWARD SECTION					
VFF output current	$I_{AC} = 300\text{ }\mu\text{A}$	-140	-150	-160	μA
SOFT START SECTION					
SS charge current		-6	-10	-16	μA
GATE DRIVER SECTION					
Pullup resistance	$I_O = -100\text{ mA}$ to -200 mA		9	12	Ω
Pulldown resistance	$I_O = 100\text{ mA}$		4	10	
Output rise time	$C_L = 1\text{ nF}$, $R_L = 10\text{ }\Omega$, $V_{DRVOUT} = 0.7\text{ V}$ to 9 V		25	50	ns
Output fall time	$C_L = 1\text{ nF}$, $R_L = 10\text{ }\Omega$, $V_{DRVOUT} = 9\text{ V}$ to 0.7 V		10	50	
Maximum duty cycle		93%	95%	99%	
Minimum controlled duty cycle	At 100 kHz			2%	
ZERO POWER SECTION					
Zero power comparator threshold	Measured on VAOUT	0.2	0.33	0.5	V

(2) Reference variation for $V_{CC} < 10.8\text{ V}$ is shown in [Figure 12](#).

8.6 Typical Characteristics

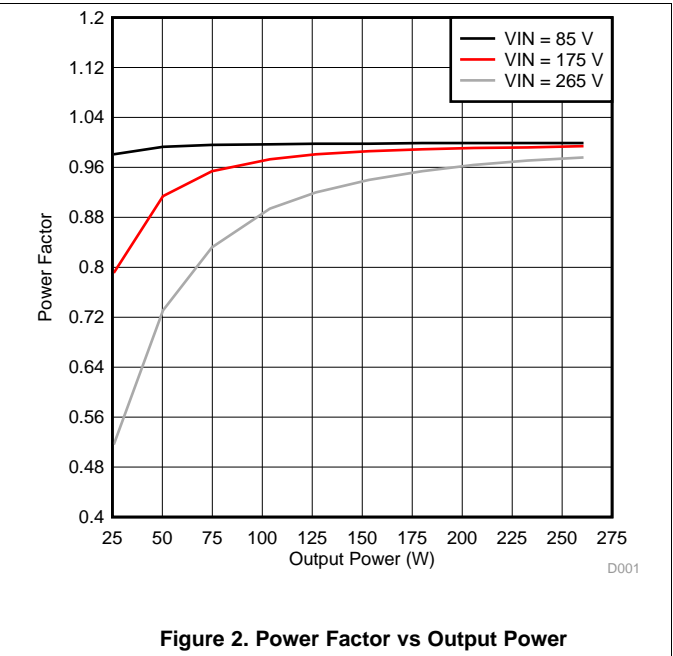
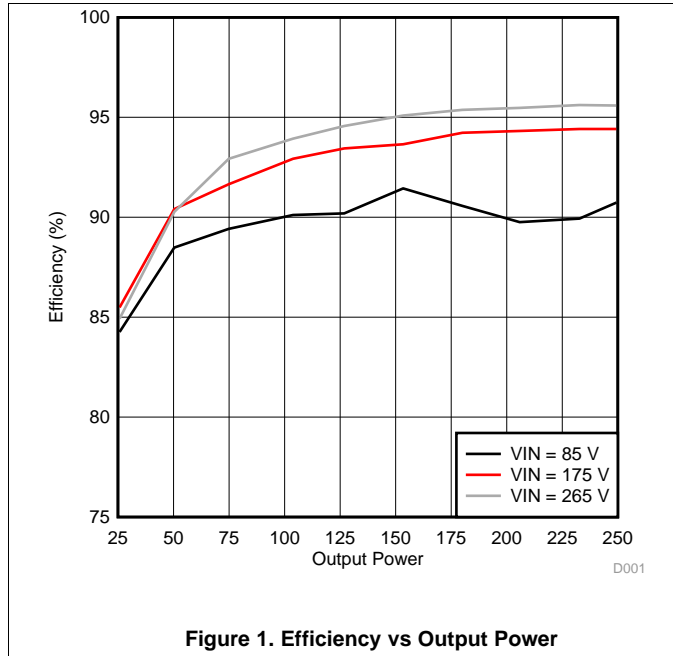

9 Detailed Description

9.1 Overview

The UCC3817A and the UCC3818A family of products provides PFC controllers all the necessary functions for achieving near unity PFC.

The UCC3817A and UCC3818A, while being pin-compatible with other industry controllers providing similar functionality, offer many feature enhancements and tighter specifications, leading to an overall reduction in system implementation cost.

The system performance is enhanced by incorporating many innovative features such as average current-mode control which maintains stable noise immune low distortion sinusoidal current. Also, the IC features a leading edge modulation which when synchronized properly with a second stage DC-DC converter can reduce the ripple current on the output capacitor thereby increasing the overall lifetime of the power supply.

In addition to these features, the key difference between the UCC281xA and the UCC381xA is that the UCC2817A can work over the extended temperature range of -40 to 85°C as opposed to 0 to 70°C in the case of the UCC3817A.

9.2 Functional Block Diagram

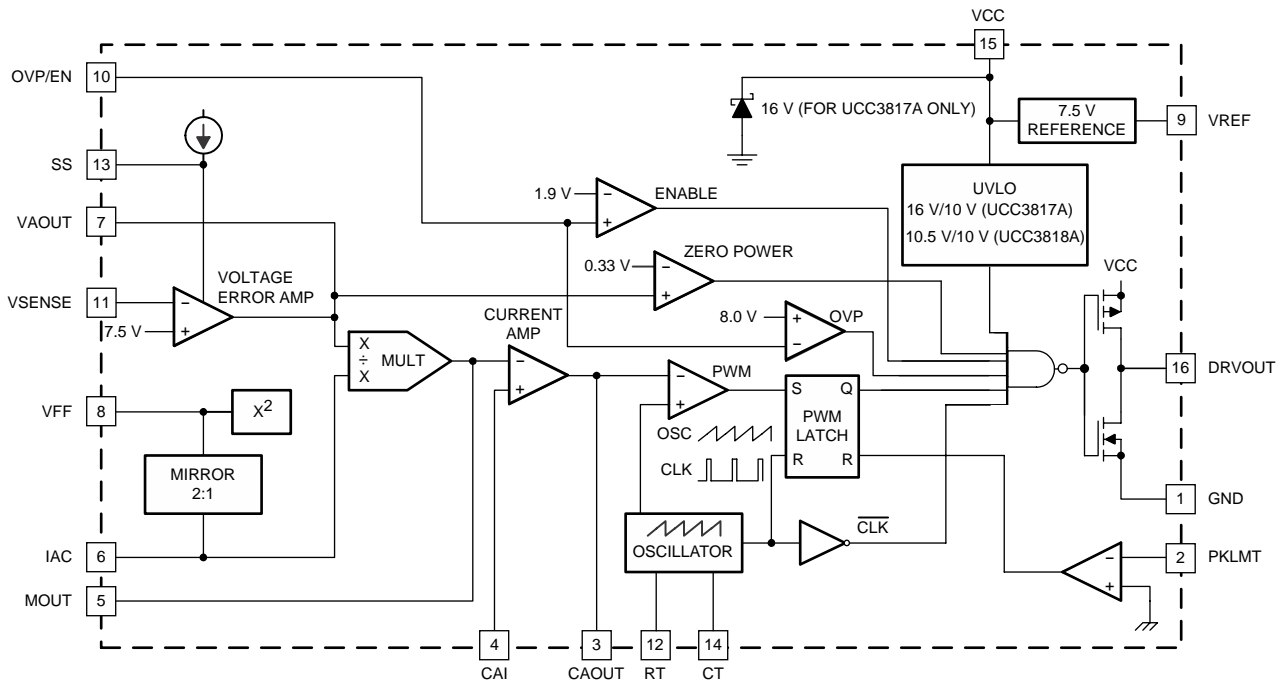

Copyright © 2016, Texas Instruments Incorporated

9.3 Feature Description

9.3.1 Reference Section and Error Amplifier

The reference is a highly accurate 7-V reference with an accuracy of the reference is 1.5%.

The error amplifier is a classic voltage error amplifier and has a short circuit current capability of 20 mA.

9.3.2 Zero Power Block

When the output of the zero power comparator goes below 2.3 V, the zero power comparator latches the gate drive signal low.

Feature Description (continued)

9.3.3 Multiplier

The multiplier has 3 inputs. The inputs to the multiplier are VAOUT, the voltage amplifier error signal, IAC, a representation of the input rectified AC line voltage, and an input voltage feedforward signal, VVFF.

The multiplier performs the calculation in [Equation 1](#).

$$I_{MOUNT} = IAC \times (VVAOUT - 1) / (K \times VVff^2)$$

where

- $K = 1/V$ (1)

As the multiplier output is a current, this is a high-impedance input so the amplifier can be configured as a differential amplifier. This configuration improves noise immunity and allows for the leading-edge modulation operation.

9.3.4 Output Overvoltage Protection

When the output voltage exceeds the OVP threshold, the IC stops switching. The OVP reference is at 1.07%. There is also a 500 mV of hysteresis at the pin.

9.3.5 Pin Descriptions

9.3.5.1 CAI

Place a resistor between this pin and the GND side of current sense resistor. This input and the inverting input (MOUT) remain functional down to and below GND.

9.3.5.2 CAOUT

This is the output of a wide bandwidth operational amplifier that senses line current and commands the PFC pulse-width modulator (PWM) to force the correct duty cycle. Compensation components are placed between CAOUT and MOUT.

9.3.5.3 CT

A capacitor from CT to GND sets the PWM oscillator frequency according to [Equation 2](#):

$$f \approx \left(\frac{0.6}{RT \times CT} \right)$$
 (2)

The lead from the oscillator timing capacitor to GND should be as short and direct as possible.

9.3.5.4 DRVOUT

The output drive for the boost switch is a totem-pole MOSFET gate driver on DRVOUT. To avoid the excessive overshoot of the DRVOUT while driving a capacitive load, a series gate current-limiting/damping resistor is recommended to prevent interaction between the gate impedance and the output driver. The value of the series gate resistor is based on the pulldown resistance ($R_{pull\down}$ which is 4 Ω typical), the maximum VCC voltage (VCC), and the required maximum gate drive current (I_{MAX}). Using [Equation 3](#), a series gate resistance of resistance 11 Ω would be required for a maximum VCC voltage of 18 V and for 1.2 A of maximum sink current. The source current will be limited to approximately 900 mA (based on the $R_{pull\up}$ of 9- Ω typical).

$$R_{GATE} = \frac{VCC - (I_{MAX} \times R_{pull\down})}{I_{MAX}}$$
 (3)

9.3.5.5 GND

All voltages measured with respect to ground. VCC and REF should be bypassed directly to GND with a 0.1- μ F or larger ceramic capacitor.

Feature Description (continued)

9.3.5.6 IAC

This input to the analog multiplier is a current proportional to instantaneous line voltage. The multiplier is tailored for very low distortion from this current input (I_{IAC}) to multiplier output. The recommended maximum I_{IAC} is 500 μ A.

9.3.5.7 MOUT

The output of the analog multiplier and the inverting input of the current amplifier are connected together at MOUT. As the multiplier output is a current, this is a high-impedance input so the amplifier can be configured as a differential amplifier. This configuration improves noise immunity and allows for the leading-edge modulation operation. The multiplier output current is limited to ($2 \times I_{IAC}$). The multiplier output current is given by [Equation 4](#):

$$I_{MOUT} = \frac{I_{IAC} \times (V_{VAOUT} - 1)}{V_{VFF}^2 \times K} \quad (4)$$

where $K = \frac{1}{V}$ is the multiplier gain constant.

9.3.5.8 OVP/EN

A window comparator input that disables the output driver if the boost output voltage is a programmed level above the nominal or disables both the PFC output driver and resets SS if pulled below 1.9 V (typical).

9.3.5.9 PKLMT

The threshold for peak limit is 0 V. Use a resistor divider from the negative side of the current sense resistor to VREF to level shift this signal to a voltage level defined by the value of the sense resistor and the peak current limit. Peak current limit is reached when PKLMT voltage falls below 0 V.

9.3.5.10 RT

A resistor from RT to GND is used to program oscillator charging current. TI recommends a resistor between 10 k Ω and 100 k Ω . Nominal voltage on this pin is 3 V.

9.3.5.11 SS

VSS is discharged for VVCC low conditions. When enabled, SS charges an external capacitor with a current source. This voltage is used as the voltage error signal during start-up, enabling the PWM duty cycle to increase slowly. In the event of a V_{VCC} dropout, the OVP/EN is forced below 1.9 V (typ), SS quickly discharges to disable the PWM.

NOTE

In an open-loop test circuit, grounding the SS pin does not ensure 0% duty cycle. See the application section for details.

9.3.5.12 VAOUT

This is the output of the operational amplifier that regulates output voltage. The voltage amplifier output is internally limited to approximately 5.5 V to prevent overshoot.

9.3.5.13 VCC

Connect to a stable source of at least 20 mA from 10 V to 17 V for normal operation. Bypass VCC directly to GND to absorb supply current spikes required to charge external MOSFET gate capacitances. To prevent inadequate gate drive signals, the output devices are inhibited unless V_{VCC} exceeds the upper undervoltage lockout voltage threshold and remains above the lower threshold.

Feature Description (continued)

9.3.5.14 VFF

The RMS voltage signal generated at this pin by mirroring 1/2 of the I_{IAC} into a single pole external filter. At low line, the VFF voltage should be 1.4 V.

9.3.5.15 VSENSE

This is normally connected to a compensation network and to the boost converter output through a divider network.

9.3.5.16 VREF

VREF is the output of an accurate 7.5-V voltage reference. This output is capable of delivering 20 mA to peripheral circuitry and is internally short-circuit current limited. VREF is disabled and remains at 0 V when V_{VCC} is below the UVLO threshold. Bypass VREF to GND with a 0.1- μ F or larger ceramic capacitor for best stability. See [Figure 12](#) and [Figure 13](#) for VREF line and load regulation characteristics.

9.4 Device Functional Modes

9.4.1 Transition Mode Control

The boost converter, the most common topology used for power factor correction, can operate in two modes: continuous conduction mode (CCM) and discontinuous conduction mode (DCM). Transition mode control, also referred to as critical conduction mode (CRM) or boundary conduction mode, maintains the converter at the boundary between CCM and DCM by adjusting the switching frequency.

The CRM converter typically uses a variation of hysteretic control, with the lower boundary equal to zero current. It is a variable frequency control technique that has inherently stable input current control while eliminating reverse recovery rectifier losses. As shown in [Figure 3](#), the switch current is compared to the reference signal (output of the multiplier) directly. This control method has the advantage of simple implementation and good power factor correction.

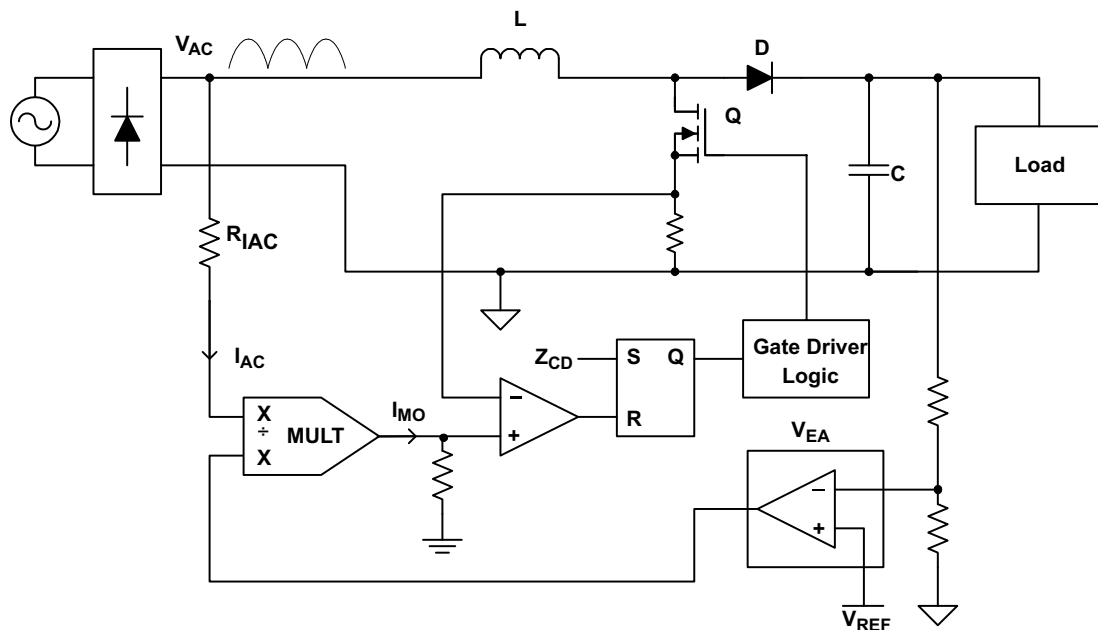

UDG-02124

Figure 3. Basic Block Diagram of CRM Boost PFC

Device Functional Modes (continued)

The power stage equations and the transfer functions of the CRM are the same as the CCM. However, implementations of the control functions are different. Transition mode forces the inductor current to operate just at the border of CCM and DCM. The current profile is also different, and affects the component power loss and filtering requirements. The peak current in the CRM boost is twice the amplitude of CCM, leading to higher conduction losses. The peak-to-peak ripple is twice the average current, which affects MOSFET switching losses and magnetics ac losses.

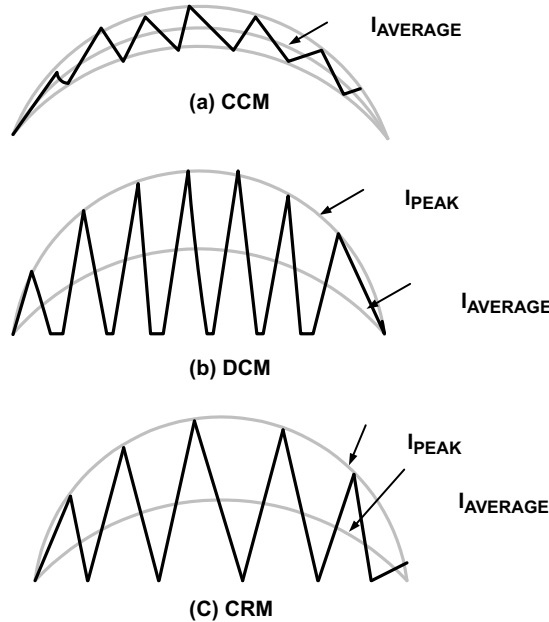

Note: Operating Frequency >> 120 Hz

UDG-02123

Figure 4. PFC Inductor Current Profiles

For low to medium power applications up to approximately 300 W, the CRM boost has an advantage in losses. The filtering requirement is not severe, and therefore is not a disadvantage. For medium to higher power applications, where the input filter requirements dominate the size of the magnetics, the CCM boost is a good choice due to lower peak currents (which reduces conduction losses) and lower ripple current (which reduces filter requirements). The main tradeoff in using CRM boost is lower losses due to no reverse recovery in the boost diode vs higher ripple and peak currents.

10 Application and Implementation

NOTE

Information in the following applications sections is not part of the TI component specification, and TI does not warrant its accuracy or completeness. TI's customers are responsible for determining suitability of components for their purposes. Customers should validate and test their design implementation to confirm system functionality.

10.1 Application Information

The UCC3817A is a BiCMOS average current mode boost controller for high power factor, high efficiency preregulator power supplies. [Figure 5](#) shows the UCC3817A in a 250-W PFC preregulator circuit. Off-line switching power converters normally have an input current that is not sinusoidal. The input current waveform has a high harmonic content because current is drawn in pulses at the peaks of the input voltage waveform. An active power factor correction circuit programs the input current to follow the line voltage, forcing the converter to look like a resistive load to the line. A resistive load has 0° phase displacement between the current and voltage waveforms. Power factor can be defined in terms of the phase angle between two sinusoidal waveforms of the same frequency:

$$PF = \cos \Theta \quad (5)$$

Therefore, a purely resistive load would have a power factor of 1. In practice, power factors of 0.999 with THD (total harmonic distortion) of less than 3% are possible with a well-designed circuit. See the following guidelines for designing PFC boost converters using the UCC3817A.

NOTE

Schottky diodes, D5 and D6, are required to protect the PFC controller from electrical over stress during system power up.

10.2 Typical Application

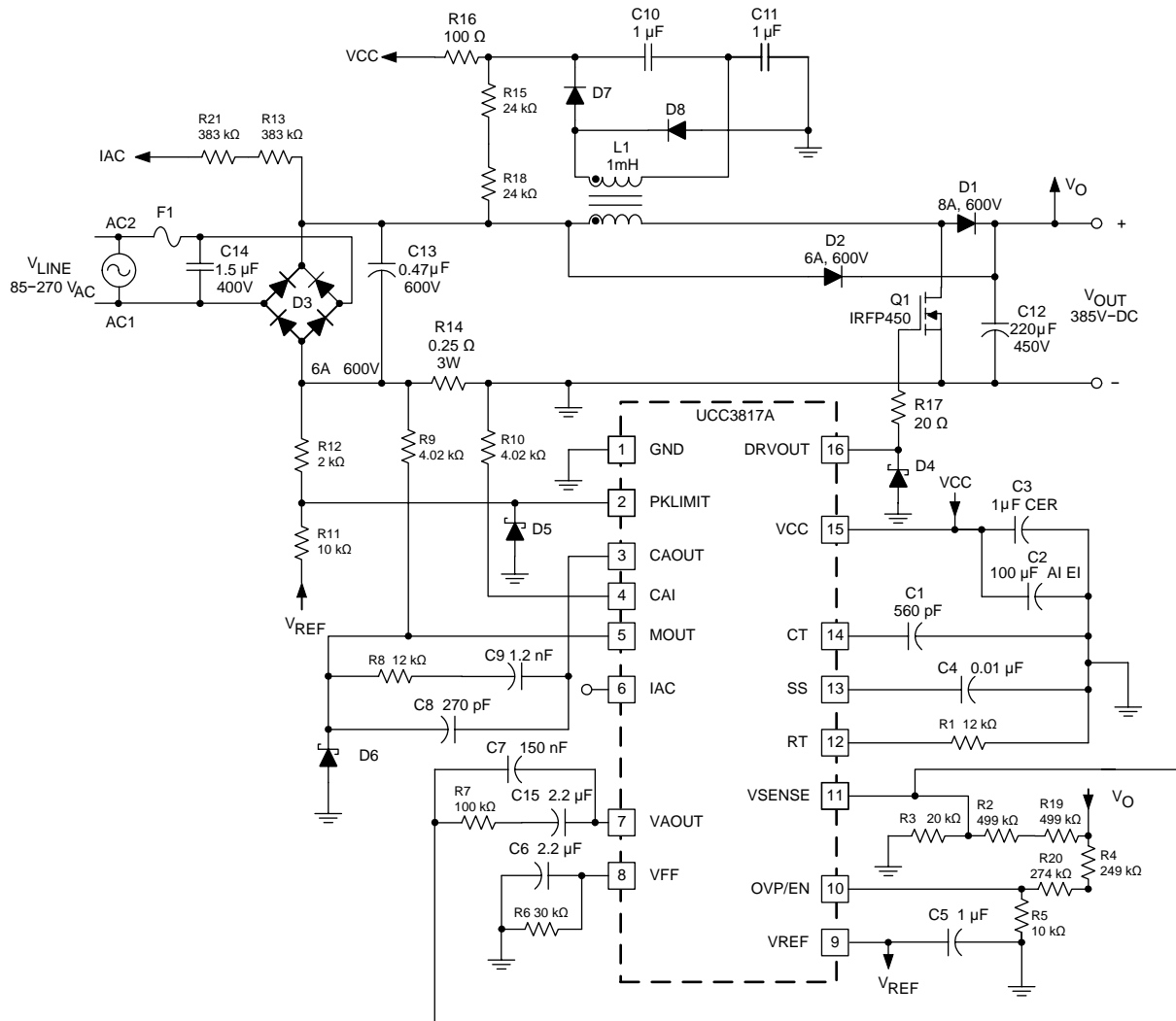

Copyright © 2016, Texas Instruments Incorporated

Figure 5. Typical Application Circuit

10.2.1 Design Requirements

Table 3 lists the parameters for this application.

Table 3. Design Parameters

PARAMETER	TEST CONDITIONS	MIN	TYP	MAX	UNIT
VIN	Input RMS voltage	85		270	V
	Input frequency		50/60		Hz
VOUT	Output Voltage		385	420	V
POUT	Output Power		250		W
	Holdup Time	All line and load conditions	16		ms
	Efficiency	Efficiency at 85 Vrms, 100% Load	91%		
	THD at Low Line	85 Vrms = 100% Load	5%		
	THD at High Line	265 Vrms, 100% Load	15%		

10.2.2 Detailed Design Procedure

10.2.2.1 Power Stage

10.2.2.1.1 LBOOST

The boost inductor value is determined by [Equation 6](#):

$$L_{\text{BOOST}} = \frac{(V_{\text{IN}(\text{min})} \times D)}{(\Delta I \times f_s)} \quad (6)$$

where D is the duty cycle, DI is the inductor ripple current and fS is the switching frequency. For the example circuit a switching frequency of 100 kHz, a ripple current of 875 mA, a maximum duty cycle of 0.688 and a minimum input voltage of 85 VRMS gives us a boost inductor value of about 1 mH. The values used in this equation are at the peak of low line, where the inductor current and its ripple are at a maximum.

10.2.2.1.2 C_{OUT}

Two main criteria, the capacitance and the voltage rating, dictate the selection of the output capacitor. The value of capacitance is determined by the holdup time required for supporting the load after input ac voltage is removed. Holdup is the amount of time that the output stays in regulation after the input has been removed. For this circuit, the desired holdup time is approximately 16 ms. Expressing the capacitor value in terms of output power, output voltage, and holdup time gives [Equation 7](#):

$$C_{\text{OUT}} = \frac{(2 \times P_{\text{OUT}} \times \Delta t)}{(V_{\text{OUT}}^2 - V_{\text{OUT}(\text{min})}^2)} \quad (7)$$

In practice, the calculated minimum capacitor value may be inadequate because output ripple voltage specifications limit the amount of allowable output capacitor ESR. Attaining a sufficiently low value of ESR often necessitates the use of a much larger capacitor value than calculated. The amount of output capacitor ESR allowed can be determined by dividing the maximum specified output ripple voltage by the inductor ripple current. In this design holdup time was the dominant determining factor and a 220-μF, 450-V capacitor was chosen for the output voltage level of 385 VDC at 250 W.

10.2.2.1.3 Power Switch Selection

As in any power supply design, tradeoffs between performance, cost and size have to be made. When selecting a power switch, it can be useful to calculate the total power dissipation in the switch for several different devices at the switching frequencies being considered for the converter. Total power dissipation in the switch is the sum of switching loss and conduction loss. Switching losses are the combination of the gate charge loss, C_{OSS} loss and turnon and turnoff losses, as shown in [Equation 8](#), [Equation 9](#), and [Equation 10](#).

$$P_{\text{GATE}} = Q_{\text{GATE}} \times V_{\text{GATE}} \times f_s \quad (8)$$

$$P_{\text{COSS}} = \frac{1}{2} \times C_{\text{OSS}} \times V_{\text{OFF}}^2 \times f_s \quad (9)$$

$$P_{\text{ON}} + P_{\text{OFF}} = \frac{1}{2} \times V_{\text{OFF}} \times I_L (t_{\text{ON}} + t_{\text{OFF}}) \times f_s$$

where

- Q_{GATE} is the total gate charge
- V_{GATE} is the gate drive voltage
- f_s is the clock frequency
- C_{OSS} is the drain source capacitance of the MOSFET
- I_L is the peak inductor current
- t_{ON} and t_{OFF} are the switching times (estimated using device parameters R_{GATE}
- Q_{GD} and V_{TH}) and V_{OFF} is the voltage across the switch during the off time, in this case V_{OFF} = V_{OUT} (10)

Conduction loss is calculated with [Equation 11](#) as the product of the R_{DS(on)} of the switch (at the worst case junction temperature) and the square of RMS current:

$$P_{COND} = R_{DS(on)} \times K \times I_{RMS}^2$$

where

- K is the temperature factor found in the manufacturer's $R_{DS(on)}$ vs. junction temperature curves (11)

Calculating these losses and plotting against frequency gives a curve that enables the designer to determine either which manufacturer's device has the best performance at the desired switching frequency, or which switching frequency has the least total loss for a particular power switch. For this design example an IRFP450 HEXFET from International Rectifier was chosen because of its low $R_{DS(on)}$ and its V_{DSS} rating. The IRFP450's $R_{DS(on)}$ of 0.4 Ω and the maximum V_{DSS} of 500 V made it an ideal choice. An excellent review of this procedure can be found in the Unitrode Power Supply Design Seminar SEM1200, Topic 6, Design Review: 140 W, [Multiple Output High Density DC/DC Converter].

10.2.2.2 Soft Start

The soft-start circuitry is used to prevent overshoot of the output voltage during start-up. This is accomplished by bringing up the voltage amplifier's output (V_{VAOUT}) slowly which allows for the PWM duty cycle to increase slowly. Use the following equation to select a capacitor for the soft-start pin.

In this example t_{DELAY} is equal to 7.5 ms, which would yield a C_{SS} of 10 nF.

$$C_{SS} = \frac{10\mu A \times t_{DELAY}}{7.5V} \quad (12)$$

In an open-loop test circuit, shorting the soft-start pin to ground does not ensure 0% duty cycle. This is due to the current amplifier's input offset voltage, which could force the current amplifier output high or low depending on the polarity of the offset voltage. However, in the typical application there is sufficient amount of inrush and bias current to overcome the current amplifier's offset voltage.

10.2.2.3 Multiplier

The output of the multiplier of the UCC3817A is a signal representing the desired input line current. It is an input to the current amplifier, which programs the current loop to control the input current to give high power factor operation. As such, the proper functioning of the multiplier is key to the success of the design. The inputs to the multiplier are VAOUT, the voltage amplifier error signal, I_{IAC}, a representation of the input rectified ac line voltage, and an input voltage feedforward signal, V_{VFF} . The output of the multiplier, I_{MOUT} , can be expressed as shown in Equation 13.

$$I_{MOUT} = I_{IAC} \times \frac{(V_{VAOUT} - 1)}{K \times V_{VFF}^2}$$

where

- K is a constant typically equal to 1 / V. (13)

The [Electrical Characteristics](#) table covers all the required operating conditions for designing with the multiplier. Additionally, curves in [Figure 14](#), [Figure 15](#), and [Figure 16](#) provide typical multiplier characteristics over its entire operating range.

The I_{IAC} signal is obtained through a high-value resistor connected between the rectified ac line and the IAC pin of the UCC3817A and UCC3818A. This resistor (R_{IAC}) is sized to give the maximum I_{IAC} current at high line. For the UCC3817A and UCC3818A the maximum I_{IAC} current is about 500 mA. A higher current than this can drive the multiplier out of its linear range. A smaller current level is functional, but noise can become an issue, especially at low input line. Assuming a universal line operation of 85 V_{RMS} to 265 V_{RMS} gives a R_{IAC} value of 750 k Ω . Because of voltage rating constraints of standard 1/4-W resistor, use a combination of lower value resistors connected in series to give the required resistance and distribute the high voltage amongst the resistors. For this design example two 383-k Ω resistors were used in series.

The current into the IAC pin is mirrored internally to the VFF pin where it is filtered to produce a voltage feed forward signal proportional to line voltage. The VFF voltage is used to keep the power stage gain constant; and to provide input power limiting. See Texas Instruments application note [Unitrode - UC3854A/B and UC3855A/B Provide Power Limiting With Sinusoidal Input Current for PFC Front Ends](#) (SLUA196) for a detailed explanation on how the VFF pin provides power limiting. Equation 14 can be used to size the VFF resistor (R_{VFF}) to provide power limiting where $V_{IN(min)}$ is the minimum RMS input voltage and R_{IAC} is the total resistance connected between the IAC pin and the rectified line voltage.

$$R_{VFF} = \frac{1.4 \text{ V}}{\frac{V_{IN(min)} \times 0.9}{2 \times R_{IAC}}} \approx 30 \text{ k}\Omega \quad (14)$$

Because the VFF voltage is generated from line voltage it needs to be adequately filtered to reduce total harmonic distortion caused by the 120 Hz rectified line voltage. Refer to the Unitrode Power Supply Design Seminar, *SEM-700 Topic 7, [Optimizing the Design of a High Power Factor Preregulator.]* A single pole filter was adequate for this design. Assuming that an allocation of 1.5% total harmonic distortion from this input is allowed, and that the second harmonic ripple is 66% of the input ac line voltage, the amount of attenuation required by this filter is:

$$\frac{1.5\%}{66\%} = 0.022 \quad (15)$$

With a ripple frequency (f_R) of 120 Hz and an attenuation of 0.022 requires that the pole of the filter (f_P) be placed at:

$$f_P = 120 \text{ Hz} \times 0.022 \approx 2.6 \text{ Hz} \quad (16)$$

Equation 17 can be used to select the filter capacitor (C_{VFF}) required to produce the desired low pass filter.

$$C_{VFF} = \frac{1}{2 \times \pi \times R_{VFF} \times f_P} \approx 2.2 \text{ }\mu\text{F} \quad (17)$$

The R_{MOUT} resistor is sized to match the maximum current through the sense resistor to the maximum multiplier current. The maximum multiplier current, or $I_{MOUT(max)}$, can be determined by Equation 18:

$$I_{MOUT(max)} = \frac{I_{IAC} @ V_{IN(min)} \times (V_{VAOUT(max)} - 1 \text{ V})}{K \times V_{VFF^2(min)}} \quad (18)$$

$I_{MOUT(max)}$ for this design is approximately 315 mA. The R_{MOUT} resistor can then be determined by Equation 19:

$$R_{MOUT} = \frac{V_{RSENSE}}{I_{MOUT(max)}} \quad (19)$$

In this example V_{RSENSE} was selected to give a dynamic operating range of 1.25 V, which gives an R_{MOUT} of roughly 3.91 k Ω .

10.2.2.4 Voltage Loop

The second major source of harmonic distortion is the ripple on the output capacitor at the second harmonic of the line frequency. This ripple is fed back through the error amplifier and appears as a 3rd harmonic ripple at the input to the multiplier. The voltage loop must be compensated not just for stability but also to attenuate the contribution of this ripple to the total harmonic distortion of the system (see Figure 6).

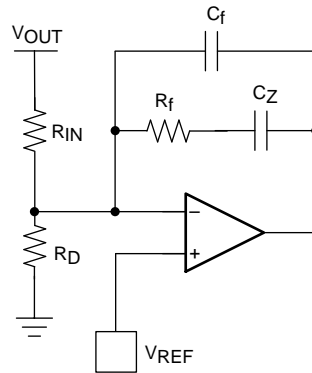

Figure 6. Voltage Amplifier Configuration

The gain of the voltage amplifier, G_{VA} , can be determined by first calculating the amount of ripple present on the output capacitor. The peak value of the second harmonic voltage is given by [Equation 20](#).

$$V_{OPK} = \frac{P_{IN}}{(2\pi \times f_R \times C_{OUT} \times V_{OUT})} \quad (20)$$

In this example V_{OPK} is equal to 3.91 V. Assuming an allowable contribution of 0.75% (1.5% peak to peak) from the voltage loop to the total harmonic distortion budget we set the gain equal to [Equation 21](#).

$$G_{VA} = \frac{(\Delta V_{VAOUT}) (0.015)}{2 \times V_{OPK}}$$

where

- ΔV_{VAOUT} is the effective output voltage range of the error amplifier (5 V for the UCC3817A). (21)

The network needed to realize this filter is comprised of an input resistor, R_{IN} , and feedback components C_f , C_z , and R_f . The value of R_{IN} is already determined because of its function as one half of a resistor divider from V_{OUT} feeding back to the voltage amplifier for output voltage regulation. In this case the value was chosen to be 1 M Ω . This high value was chosen to reduce power dissipation in the resistor. In practice, the resistor value would be realized by the use of two 500-k Ω resistors in series because of the voltage rating constraints of most standard 1/4-W resistors. The value of C_f is determined by [Equation 22](#).

$$C_f = \frac{1}{(2\pi \times f_R \times G_{VA} \times R_{IN})} \quad (22)$$

In this example C_f equals 150 nF. Resistor R_f sets the dc gain of the error amplifier and thus determines the frequency of the pole of the error amplifier. The location of the pole can be found by setting the gain of the loop equation to one and solving for the crossover frequency. The frequency, expressed in terms of input power, can be calculated by [Equation 23](#).

$$f_{VI}^2 = \frac{P_{IN}}{\left((2\pi)^2 \times \Delta V_{VAOUT} \times V_{OUT} \times R_{IN} \times C_{OUT} \times C_f \right)} \quad (23)$$

f_{VI} for this converter is 10 Hz. A derivation of this equation can be found in the Unitrode Power Supply Design Seminar SEM1000, Topic 1, [A 250-kHz, 500-W Power Factor Correction Circuit Employing Zero Voltage Transitions].

Solving for R_f becomes [Equation 24](#).

$$R_f = \frac{1}{(2\pi \times f_{VI} \times C_f)} \quad (24)$$

or R_f equals 100 k Ω .

Due to the low output impedance of the voltage amplifier, capacitor C_Z was added in series with R_F to reduce loading on the voltage divider. To ensure the voltage loop crossed over at f_{VI} , C_Z was selected to add a zero at a 10th of f_{VI} . For this design, a 2.2- μF capacitor was chosen for C_Z . Equation 25 can be used to calculate C_Z .

$$C_Z = \frac{1}{2 \times \pi \times \frac{f_{VI}}{10} \times R_f} \quad (25)$$

10.2.2.5 Current Loop

The gain of the power stage is calculated by Equation 26.

$$G_{ID}(s) = \frac{(V_{OUT} \times R_{SENSE})}{(s \times L_{BOOST} \times VP)} \quad (26)$$

R_{SENSE} has been chosen to give the desired differential voltage for the current sense amplifier at the desired current limit point. In this example, a current limit of 4 A and a reasonable differential voltage to the current amp of 1 V gives a R_{SENSE} value of 0.25 Ω . VP in Equation 26 is the voltage swing of the oscillator ramp, 4 V for the UCC3817A. Setting the crossover frequency of the system to 1/10th of the switching frequency, or 10 kHz, requires a power stage gain at that frequency of 0.383. For the system to have a gain of 1 at the crossover frequency, the current amplifier needs to have a gain of $1/G_{ID}$ at that frequency. G_{EA} , the current amplifier gain is then:

$$G_{EA} = \frac{1}{G_{ID}} = \frac{1}{0.383} = 2.611 \quad (27)$$

R_I is the R_{MOUT} resistor, previously calculated to be 3.9 k Ω . (see Figure 7). The gain of the current amplifier is R_f/R_I , so multiplying R_I by G_{EA} gives the value of R_f , in this case approximately 12 k Ω . Setting a zero at the crossover frequency and a pole at half the switching frequency completes the current loop compensation.

$$C_Z = \frac{1}{2 \times \pi \times R_f \times f_c} \quad (28)$$

$$C_P = \frac{1}{2 \times \pi \times R_f \times \frac{f_s}{2}} \quad (29)$$

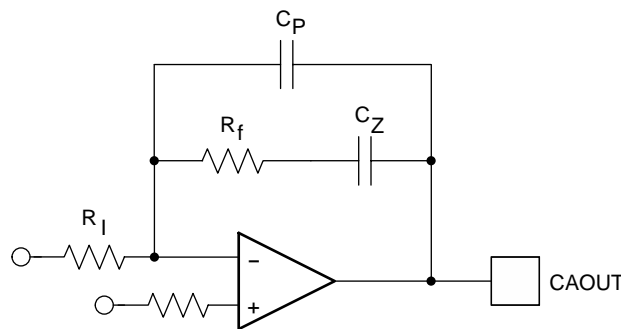

Figure 7. Current Loop Compensation

The UCC3817A current amplifier has the input from the multiplier applied to the inverting input. This change in architecture from previous Texas Instruments PFC controllers improves noise immunity in the current amplifier. It also adds a phase inversion into the control loop. The UCC3817A takes advantage of this phase inversion to implement leading-edge duty cycle modulation. Synchronizing a boost PFC controller to a downstream dc-to-dc controller reduces the ripple current seen by the bulk capacitor between stages, reducing capacitor size and cost and reducing EMI. This is explained in greater detail in the following section. The UCC3817A current amplifier configuration is shown in Figure 8.

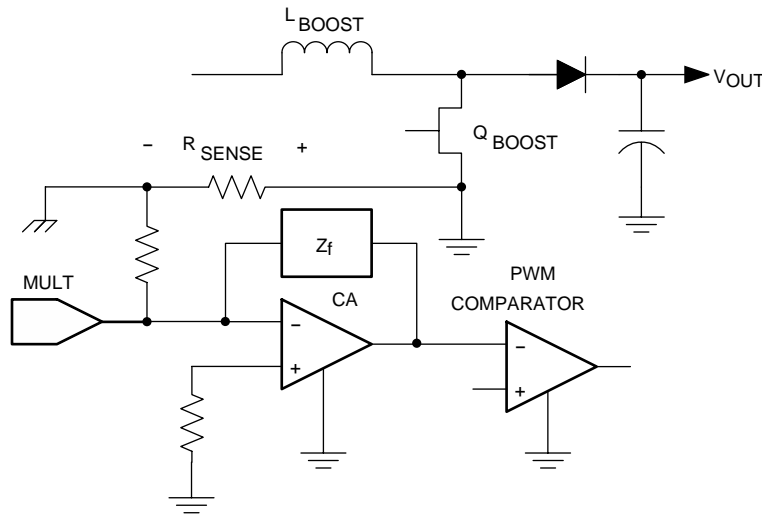

Figure 8. UCC3817A Current Amplifier Configuration

10.2.2.6 Start-Up

The UCC3818A version of the device is intended to have VCC connected to a 12-V supply voltage. The UCC3817A has an internal shunt regulator enabling the device to be powered from bootstrap circuitry as shown in the typical application circuit of Figure 5. The current drawn by the UCC3817A during undervoltage lockout, or start-up current, is typically 150 μ A. Once VCC is above the UVLO threshold, the device is enabled and draws 4 mA typically. A resistor connected between the rectified ac line voltage and the VCC pin provides current to the shunt regulator during power up. Once the circuit is operational, the bootstrap winding of the inductor provides the VCC voltage. Sizing of the start-up resistor is determined by the start-up time requirement of the system design.

$$I_C = C \frac{\Delta V}{\Delta t} \quad (30)$$

$$R = \frac{V_{RMS} \times (0.9)}{I_C}$$

where

- I_C is the charge current
 - C is the total capacitance at the VCC pin
 - ΔV is the UVLO threshold and Δt is the allowed start-up time
- (31)

Assuming a 1 second allowed start-up time, a 16-V UVLO threshold, and a total VCC capacitance of 100 μ F, a resistor value of 51 k Ω is required at a low line input voltage of 85 V_{RMS} . The IC start-up current is sufficiently small as to be ignored in sizing the start-up resistor.

10.2.2.7 Capacitor Ripple Reduction

For a power system where the PFC boost converter is followed by a dc-to-dc converter stage, there are benefits to synchronizing the two converters. In addition to the usual advantages such as noise reduction and stability, proper synchronization can significantly reduce the ripple currents in the boost circuit's output capacitor. Figure 9 helps illustrate the impact of proper synchronization by showing a PFC boost converter together with the simplified input stage of a forward converter. The capacitor current during a single switching cycle depends on the status of the switches Q1 and Q2 and is shown in Figure 10. It can be seen that with a synchronization scheme that maintains conventional trailing-edge modulation on both converters, the capacitor current ripple is highest. The greatest ripple current cancellation is attained when the overlap of Q1 off-time and Q2 on-time is maximized. One method of achieving this is to synchronize the turnon of the boost diode (D1) with the turnon of

Q2. This approach implies that the boost converter's leading edge is pulse width modulated while the forward converter is modulated with traditional trailing edge PWM. The UCC3817A is designed as a leading edge modulator with easy synchronization to the downstream converter to facilitate this advantage. Table 4 compares the $I_{CB(rms)}$ for D1/Q2 synchronization as offered by UCC3817A vs the $I_{CB(rms)}$ for the other extreme of synchronizing the turnon of Q1 and Q2 for a 200-W power system with a V_{BST} of 385 V.

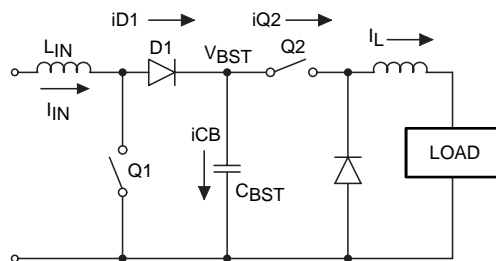

Figure 9. Simplified Representation of a 2-Stage PFC Power Supply

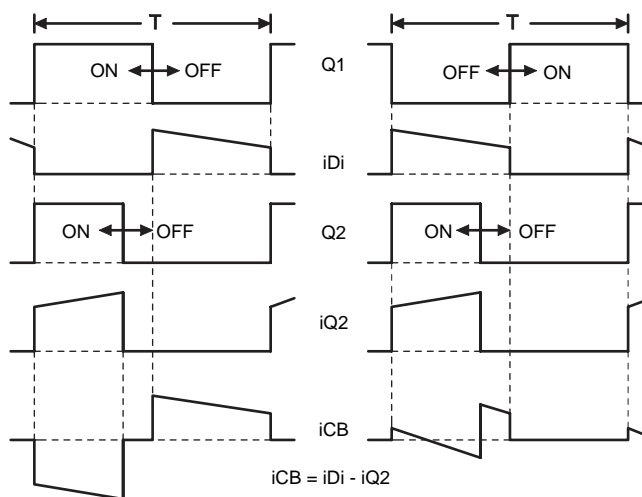

Figure 10. Timing Waveforms for Synchronization Scheme

Table 4 illustrates that the boost capacitor ripple current can be reduced by about 50% at nominal line and about 30% at high line with the synchronization scheme facilitated by the UCC3817A. Figure 11 shows the suggested technique for synchronizing the UCC3817A to the downstream converter. With this technique, maximum ripple reduction as shown in Figure 10 is achievable. The output capacitance value can be significantly reduced if its choice is dictated by ripple current or the capacitor life can be increased as a result. In cost sensitive designs where holdup time is not critical, this is a significant advantage.

Table 4. Effects of Synchronization on Boost Capacitor Current

D(Q2)	$V_{IN} = 85 \text{ V}$		$V_{IN} = 120 \text{ V}$		$V_{IN} = 240 \text{ V}$	
	Q1/Q2	D1/Q2	Q1/Q2	D1/Q2	Q1/Q2	D1/Q2
0.35	1.491 A	0.835 A	1.341 A	0.663 A	1.024 A	0.731 A
0.45	1.432A	0.93 A	1.276 A	0.664 A	0.897 A	0.614 A

An alternative method of synchronization to achieve the same ripple reduction is possible. In this method, the turnon of Q1 is synchronized to the turnoff of Q2. While this method yields almost identical ripple reduction and maintains trailing edge modulation on both converters, the synchronization is much more difficult to achieve and the circuit can become susceptible to noise as the synchronizing edge itself is being modulated.

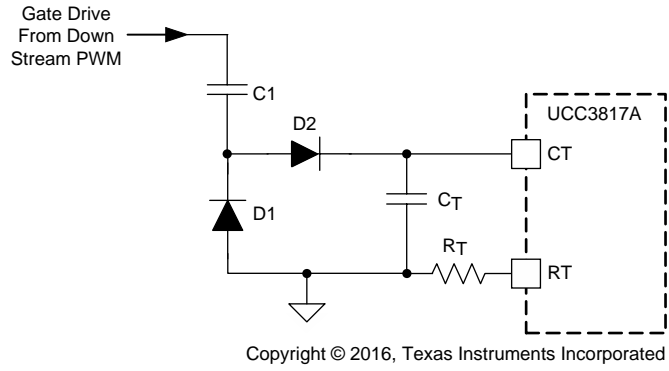
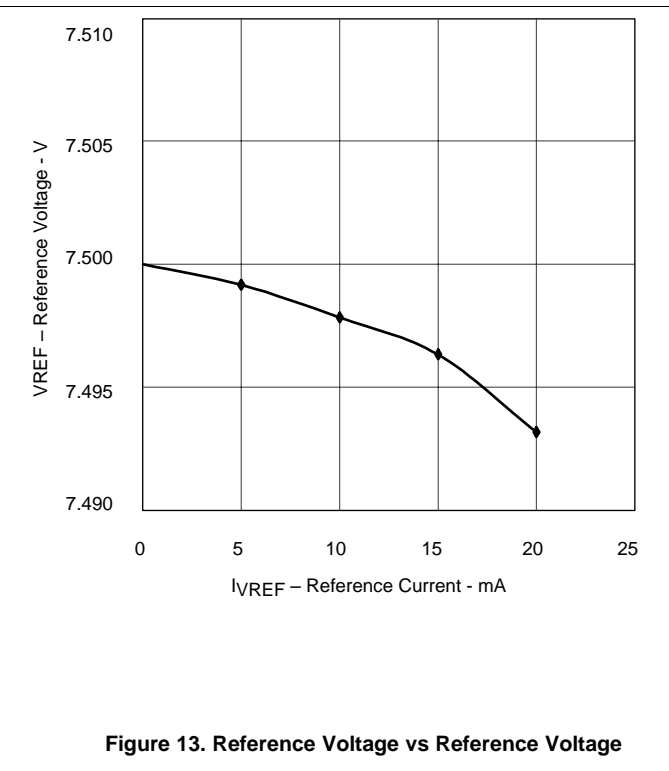
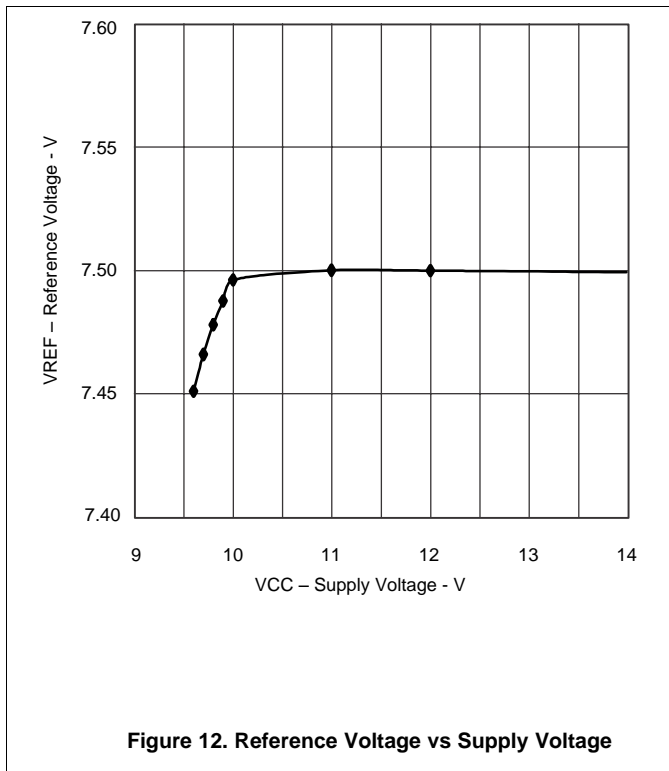

Figure 11. Synchronizing the UCC3817A to a Down-Stream Converter

10.2.3 Application Curves



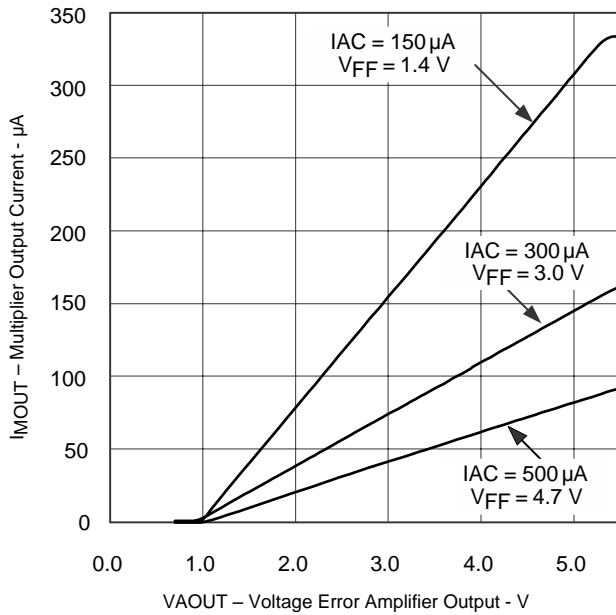

Figure 14. Multiplier Output Current vs Voltage Error Amplifier Output

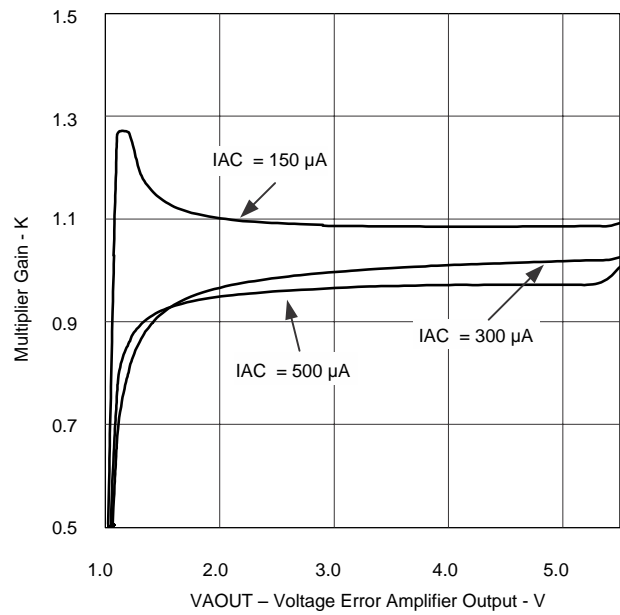

Figure 15. Multiplier Gain vs Voltage Error Amplifier Output

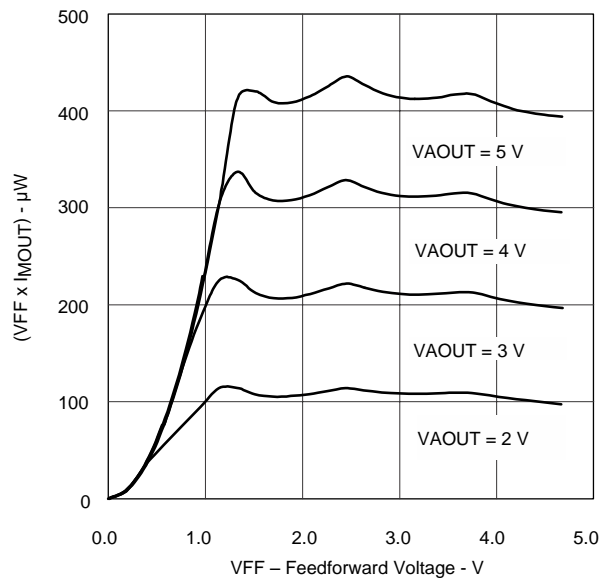

Figure 16. Multiplier Constant Power Performance

11 Power Supply Recommendations

The supply voltage for the device comes from VCC pin. This pin must be bypassed with a high-frequency capacitor (greater than 1 μF) and tied to GND. The UCC3817A and UCC2817A has a wide UVLO hysteresis of approximately 6.3 V that allows use of a lower value supply capacitor on this pin for quicker and easier start-up.

12 Layout

12.1 Layout Guidelines

12.1.1 Bias Current

The bias voltage is supplied either by an external dedicated DC-DC converter or by an auxiliary winding from the PFC inductor or the 2nd stage DC-DC converter.

The bias capacitor should be large enough to maintain sufficient voltage with AC line variations. Connect a 1- μF capacitor between VCC and GND as close to the IC as possible. For wide line voltages, an additional 18-V Zener clamp can also be used.

12.1.2 VREF

Connect a capacitor $\geq 0.1 \mu\text{F}$ between VREF and GND for stability.

12.2 Layout Example

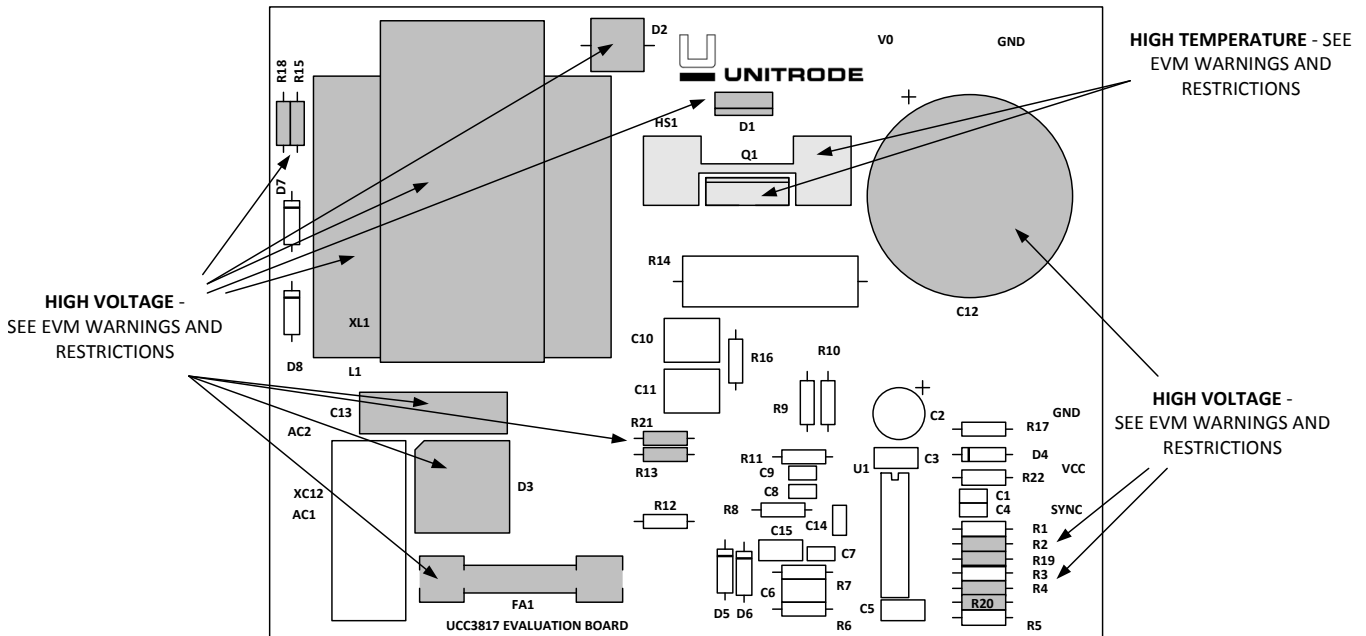

Figure 17. UCC3817EVM Evaluation Board Layout Assembly

13 Device and Documentation Support

13.1 Documentation Support

13.1.1 Related Documentation

For related documentation see the following:

1. [Differences Between UCC3817A/18A/19A and UCC3817/18/19](#) (SLUA294)
2. [UCC3817 BiCMOS Power Factor Preregulator Evaluation Board](#) (SLUU077)
3. [Synchronizing a PFC Controller from a Down Stream Controller Gate Drive](#) (SLUA245)
4. Seminar topic, *High Power Factor Switching Preregulator Design Optimization*, L.H. Dixon, SEM-700,1990.
5. Seminar topic, *High Power Factor Preregulator for Off-line Supplies*, L.H. Dixon, SEM-600, 1988.

13.2 Related Links

The table below lists quick access links. Categories include technical documents, support and community resources, tools and software, and quick access to sample or buy.

Table 5. Related Links

PARTS	PRODUCT FOLDER	SAMPLE & BUY	TECHNICAL DOCUMENTS	TOOLS & SOFTWARE	SUPPORT & COMMUNITY
UCC2817A	Click here	Click here	Click here	Click here	Click here
UCC2818A	Click here	Click here	Click here	Click here	Click here
UCC3817A	Click here	Click here	Click here	Click here	Click here
UCC3818A	Click here	Click here	Click here	Click here	Click here

13.3 Receiving Notification of Documentation Updates

To receive notification of documentation updates, navigate to the device product folder on ti.com. In the upper right corner, click on *Alert me* to register and receive a weekly digest of any product information that has changed. For change details, review the revision history included in any revised document.

13.4 Community Resource

The following links connect to TI community resources. Linked contents are provided "AS IS" by the respective contributors. They do not constitute TI specifications and do not necessarily reflect TI's views; see TI's [Terms of Use](#).

TI E2E™ Online Community *TI's Engineer-to-Engineer (E2E) Community*. Created to foster collaboration among engineers. At e2e.ti.com, you can ask questions, share knowledge, explore ideas and help solve problems with fellow engineers.

Design Support *TI's Design Support* Quickly find helpful E2E forums along with design support tools and contact information for technical support.

13.5 Trademarks

E2E is a trademark of Texas Instruments.
All other trademarks are the property of their respective owners.

13.6 Electrostatic Discharge Caution



These devices have limited built-in ESD protection. The leads should be shorted together or the device placed in conductive foam during storage or handling to prevent electrostatic damage to the MOS gates.

13.7 Glossary

[SLYZ022](#) — *TI Glossary*.

This glossary lists and explains terms, acronyms, and definitions.

14 Mechanical, Packaging, and Orderable Information

The following pages include mechanical, packaging, and orderable information. This information is the most current data available for the designated devices. This data is subject to change without notice and revision of this document. For browser-based versions of this data sheet, refer to the left-hand navigation.

PACKAGING INFORMATION

Orderable Device	Status (1)	Package Type	Package Drawing	Pins	Package Qty	Eco Plan (2)	Lead/Ball Finish (6)	MSL Peak Temp (3)	Op Temp (°C)	Device Marking (4/5)	Samples
UCC2817AD	ACTIVE	SOIC	D	16	40	Green (RoHS & no Sb/Br)	CU NIPDAU	Level-1-260C-UNLIM	-40 to 85	UCC2817AD	Samples
UCC2817ADR	ACTIVE	SOIC	D	16	2500	Green (RoHS & no Sb/Br)	CU NIPDAU	Level-1-260C-UNLIM	-40 to 85	UCC2817AD	Samples
UCC2817AN	ACTIVE	PDIP	N	16	25	Green (RoHS & no Sb/Br)	CU NIPDAU	N / A for Pkg Type	-40 to 85	UCC2817AN	Samples
UCC2817APW	ACTIVE	TSSOP	PW	16	90	Green (RoHS & no Sb/Br)	CU NIPDAU	Level-2-260C-1 YEAR	-40 to 85	2817A	Samples
UCC2817APWR	ACTIVE	TSSOP	PW	16	2000	Green (RoHS & no Sb/Br)	CU NIPDAU	Level-2-260C-1 YEAR	-40 to 85	2817A	Samples
UCC2818AD	ACTIVE	SOIC	D	16	40	Green (RoHS & no Sb/Br)	CU NIPDAU	Level-1-260C-UNLIM	-40 to 85	UCC2818AD	Samples
UCC2818ADR	ACTIVE	SOIC	D	16	2500	Green (RoHS & no Sb/Br)	CU NIPDAU	Level-1-260C-UNLIM	-40 to 85	UCC2818AD	Samples
UCC2818AN	ACTIVE	PDIP	N	16	25	Green (RoHS & no Sb/Br)	CU NIPDAU	N / A for Pkg Type	-40 to 85	UCC2818AN	Samples
UCC2818APW	ACTIVE	TSSOP	PW	16	90	Green (RoHS & no Sb/Br)	CU NIPDAU	Level-2-260C-1 YEAR	-40 to 85	2818A	Samples
UCC2818APWR	ACTIVE	TSSOP	PW	16	2000	Green (RoHS & no Sb/Br)	CU NIPDAU	Level-2-260C-1 YEAR	-40 to 85	2818A	Samples
UCC2818APWRG4	ACTIVE	TSSOP	PW	16	2000	Green (RoHS & no Sb/Br)	CU NIPDAU	Level-2-260C-1 YEAR	-40 to 85	2818A	Samples
UCC3817AD	ACTIVE	SOIC	D	16	40	Green (RoHS & no Sb/Br)	CU NIPDAU	Level-1-260C-UNLIM	0 to 70	UCC3817AD	Samples
UCC3817ADR	ACTIVE	SOIC	D	16	2500	Green (RoHS & no Sb/Br)	CU NIPDAU	Level-1-260C-UNLIM	0 to 70	UCC3817AD	Samples
UCC3817AN	ACTIVE	PDIP	N	16	25	Green (RoHS & no Sb/Br)	CU NIPDAU	N / A for Pkg Type	0 to 70	UCC3817AN	Samples
UCC3818AD	ACTIVE	SOIC	D	16	40	Green (RoHS & no Sb/Br)	CU NIPDAU	Level-1-260C-UNLIM	0 to 70	UCC3818AD	Samples
UCC3818ADR	ACTIVE	SOIC	D	16	2500	Green (RoHS & no Sb/Br)	CU NIPDAU	Level-1-260C-UNLIM	0 to 70	UCC3818AD	Samples
UCC3818AN	ACTIVE	PDIP	N	16	25	Green (RoHS & no Sb/Br)	CU NIPDAU	N / A for Pkg Type	0 to 70	UCC3818AN	Samples

Orderable Device	Status (1)	Package Type	Package Drawing	Pins	Package Qty	Eco Plan (2)	Lead/Ball Finish (6)	MSL Peak Temp (3)	Op Temp (°C)	Device Marking (4/5)	Samples
UCC3818APW	ACTIVE	TSSOP	PW	16	90	Green (RoHS & no Sb/Br)	CU NIPDAU	Level-2-260C-1 YEAR	0 to 70	3818A	Samples
UCC3818APWR	ACTIVE	TSSOP	PW	16	2000	Green (RoHS & no Sb/Br)	CU NIPDAU	Level-2-260C-1 YEAR	0 to 70	3818A	Samples

(1) The marketing status values are defined as follows:

ACTIVE: Product device recommended for new designs.

LIFEBUY: TI has announced that the device will be discontinued, and a lifetime-buy period is in effect.

NRND: Not recommended for new designs. Device is in production to support existing customers, but TI does not recommend using this part in a new design.

PREVIEW: Device has been announced but is not in production. Samples may or may not be available.

OBsolete: TI has discontinued the production of the device.

(2) **RoHS:** TI defines "RoHS" to mean semiconductor products that are compliant with the current EU RoHS requirements for all 10 RoHS substances, including the requirement that RoHS substance do not exceed 0.1% by weight in homogeneous materials. Where designed to be soldered at high temperatures, "RoHS" products are suitable for use in specified lead-free processes. TI may reference these types of products as "Pb-Free".

RoHS Exempt: TI defines "RoHS Exempt" to mean products that contain lead but are compliant with EU RoHS pursuant to a specific EU RoHS exemption.

Green: TI defines "Green" to mean the content of Chlorine (Cl) and Bromine (Br) based flame retardants meet JS709B low halogen requirements of <=1000ppm threshold. Antimony trioxide based flame retardants must also meet the <=1000ppm threshold requirement.

(3) MSL, Peak Temp. - The Moisture Sensitivity Level rating according to the JEDEC industry standard classifications, and peak solder temperature.

(4) There may be additional marking, which relates to the logo, the lot trace code information, or the environmental category on the device.

(5) Multiple Device Markings will be inside parentheses. Only one Device Marking contained in parentheses and separated by a "~" will appear on a device. If a line is indented then it is a continuation of the previous line and the two combined represent the entire Device Marking for that device.

(6) Lead/Ball Finish - Orderable Devices may have multiple material finish options. Finish options are separated by a vertical ruled line. Lead/Ball Finish values may wrap to two lines if the finish value exceeds the maximum column width.

Important Information and Disclaimer:The information provided on this page represents TI's knowledge and belief as of the date that it is provided. TI bases its knowledge and belief on information provided by third parties, and makes no representation or warranty as to the accuracy of such information. Efforts are underway to better integrate information from third parties. TI has taken and continues to take reasonable steps to provide representative and accurate information but may not have conducted destructive testing or chemical analysis on incoming materials and chemicals. TI and TI suppliers consider certain information to be proprietary, and thus CAS numbers and other limited information may not be available for release.

In no event shall TI's liability arising out of such information exceed the total purchase price of the TI part(s) at issue in this document sold by TI to Customer on an annual basis.

OTHER QUALIFIED VERSIONS OF UCC2818A :

- Automotive: [UCC2818A-Q1](#)

NOTE: Qualified Version Definitions:

- Automotive - Q100 devices qualified for high-reliability automotive applications targeting zero defects

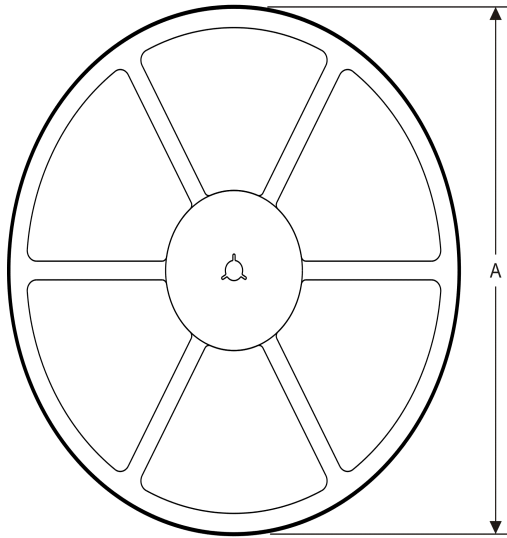
TAPE AND REEL INFORMATION
REEL DIMENSIONS

TAPE DIMENSIONS

A0	Dimension designed to accommodate the component width
B0	Dimension designed to accommodate the component length
K0	Dimension designed to accommodate the component thickness
W	Overall width of the carrier tape
P1	Pitch between successive cavity centers

TAPE AND REEL INFORMATION

*All dimensions are nominal

Device	Package Type	Package Drawing	Pins	SPQ	Reel Diameter (mm)	Reel Width W1 (mm)	A0 (mm)	B0 (mm)	K0 (mm)	P1 (mm)	W (mm)	Pin1 Quadrant
UCC2817ADR	SOIC	D	16	2500	330.0	16.4	6.5	10.3	2.1	8.0	16.0	Q1
UCC2817APWR	TSSOP	PW	16	2000	330.0	12.4	6.9	5.6	1.6	8.0	12.0	Q1
UCC2818ADR	SOIC	D	16	2500	330.0	16.4	6.5	10.3	2.1	8.0	16.0	Q1
UCC2818APWR	TSSOP	PW	16	2000	330.0	12.4	6.9	5.6	1.6	8.0	12.0	Q1
UCC3817ADR	SOIC	D	16	2500	330.0	16.4	6.5	10.3	2.1	8.0	16.0	Q1
UCC3818ADR	SOIC	D	16	2500	330.0	16.4	6.5	10.3	2.1	8.0	16.0	Q1
UCC3818APWR	TSSOP	PW	16	2000	330.0	12.4	6.9	5.6	1.6	8.0	12.0	Q1

TAPE AND REEL BOX DIMENSIONS

*All dimensions are nominal

Device	Package Type	Package Drawing	Pins	SPQ	Length (mm)	Width (mm)	Height (mm)
UCC2817ADR	SOIC	D	16	2500	333.2	345.9	28.6
UCC2817APWR	TSSOP	PW	16	2000	367.0	367.0	35.0
UCC2818ADR	SOIC	D	16	2500	333.2	345.9	28.6
UCC2818APWR	TSSOP	PW	16	2000	367.0	367.0	35.0
UCC3817ADR	SOIC	D	16	2500	333.2	345.9	28.6
UCC3818ADR	SOIC	D	16	2500	333.2	345.9	28.6
UCC3818APWR	TSSOP	PW	16	2000	367.0	367.0	35.0

D (R-PDSO-G16)

PLASTIC SMALL OUTLINE



- NOTES:
- All linear dimensions are in millimeters.
 - This drawing is subject to change without notice.
 - Publication IPC-7351 is recommended for alternate designs.
 - Laser cutting apertures with trapezoidal walls and also rounding corners will offer better paste release. Customers should contact their board assembly site for stencil design recommendations. Refer to IPC-7525 for other stencil recommendations.
 - Customers should contact their board fabrication site for solder mask tolerances between and around signal pads.



4220204/A 02/2017

NOTES:

1. All linear dimensions are in millimeters. Any dimensions in parenthesis are for reference only. Dimensioning and tolerancing per ASME Y14.5M.
2. This drawing is subject to change without notice.
3. This dimension does not include mold flash, protrusions, or gate burrs. Mold flash, protrusions, or gate burrs shall not exceed 0.15 mm per side.
4. This dimension does not include interlead flash. Interlead flash shall not exceed 0.25 mm per side.
5. Reference JEDEC registration MO-153.

EXAMPLE BOARD LAYOUT

PW0016A

TSSOP - 1.2 mm max height

SMALL OUTLINE PACKAGE



LAND PATTERN EXAMPLE
EXPOSED METAL SHOWN
SCALE: 10X



SOLDER MASK DETAILS

4220204/A 02/2017

NOTES: (continued)

- 6. Publication IPC-7351 may have alternate designs.
- 7. Solder mask tolerances between and around signal pads can vary based on board fabrication site.

EXAMPLE STENCIL DESIGN

PW0016A

TSSOP - 1.2 mm max height

SMALL OUTLINE PACKAGE



SOLDER PASTE EXAMPLE
BASED ON 0.125 mm THICK STENCIL
SCALE: 10X

4220204/A 02/2017

NOTES: (continued)

8. Laser cutting apertures with trapezoidal walls and rounded corners may offer better paste release. IPC-7525 may have alternate design recommendations.
9. Board assembly site may have different recommendations for stencil design.

IMPORTANT NOTICE AND DISCLAIMER

TI PROVIDES TECHNICAL AND RELIABILITY DATA (INCLUDING DATASHEETS), DESIGN RESOURCES (INCLUDING REFERENCE DESIGNS), APPLICATION OR OTHER DESIGN ADVICE, WEB TOOLS, SAFETY INFORMATION, AND OTHER RESOURCES "AS IS" AND WITH ALL FAULTS, AND DISCLAIMS ALL WARRANTIES, EXPRESS AND IMPLIED, INCLUDING WITHOUT LIMITATION ANY IMPLIED WARRANTIES OF MERCHANTABILITY, FITNESS FOR A PARTICULAR PURPOSE OR NON-INFRINGEMENT OF THIRD PARTY INTELLECTUAL PROPERTY RIGHTS.

These resources are intended for skilled developers designing with TI products. You are solely responsible for (1) selecting the appropriate TI products for your application, (2) designing, validating and testing your application, and (3) ensuring your application meets applicable standards, and any other safety, security, or other requirements. These resources are subject to change without notice. TI grants you permission to use these resources only for development of an application that uses the TI products described in the resource. Other reproduction and display of these resources is prohibited. No license is granted to any other TI intellectual property right or to any third party intellectual property right. TI disclaims responsibility for, and you will fully indemnify TI and its representatives against, any claims, damages, costs, losses, and liabilities arising out of your use of these resources.

TI's products are provided subject to TI's Terms of Sale (www.ti.com/legal/termsofsale.html) or other applicable terms available either on ti.com or provided in conjunction with such TI products. TI's provision of these resources does not expand or otherwise alter TI's applicable warranties or warranty disclaimers for TI products.

Mailing Address: Texas Instruments, Post Office Box 655303, Dallas, Texas 75265
Copyright © 2018, Texas Instruments Incorporated

Looking for pricing, stock, or lifecycle information?

Click below to explore more details on WIN SOURCE:

 [View UCC3818APW on WIN SOURCE](#)

 [Texas Instruments](#) Information

Optimize Your Supply Chain with WIN SOURCE Solutions

-  Global Sourcing Solution
-  Obsolete Management
-  Cost Control Management
-  Shortage Management
-  Alternative Solution
-  Excess Inventory Management