



# THE DATASHEET OF VN750-B5



**Features**

Type	$R_{DS(on)}$	$I_{OUT}$	$V_{CC}$
VN750 VN750S VN750PT VN750-B5	60 m $\Omega$	6 A	36 V

- CMOS compatible input
- On-state open-load detection
- Off-state open-load detection
- Shorted load protection
- Undervoltage and overvoltage shutdown
- Protection against loss of ground
- Very low standby current
- Reverse battery protection

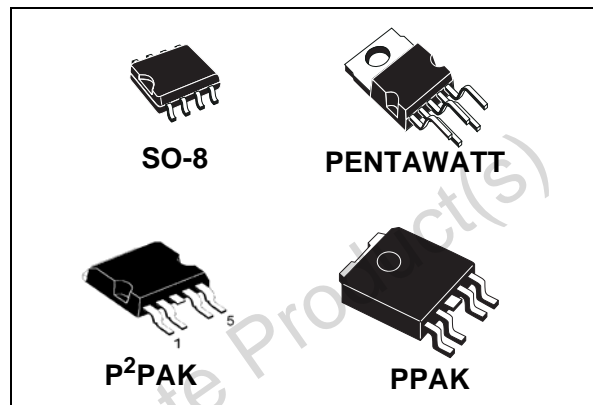
**Description**

The VN750 is a monolithic device designed using STMicroelectronic® VIPower® M0-3 technology. The VN750 is intended for driving any type of load with one side connected to ground. The active  $V_{CC}$  pin voltage clamp protects the device against low energy spikes.

Active current limitation combined with thermal shutdown and automatic restart protect the device against overload. The device detects the open-load condition in both the on-state and off-state. In the off-state the device detects if the output is shorted to  $V_{CC}$ . The device automatically turns off where the ground pin becomes disconnected.

**Table 1. Device summary**

Package	Order codes	
	Tube	Tape and reel
PENTAWATT	VN750	—
SO-8	VN750S	VN750S13TR
P <sup>2</sup> PAK	VN750-B5	VN750-B513TR
PPAK	VN750PT	VN750PT13TR

# Contents

<b>1</b>	<b>Block diagram and pin description</b>	<b>7</b>
<b>2</b>	<b>Electrical specifications</b>	<b>8</b>
2.1	Absolute maximum ratings	8
2.2	Thermal data	9
2.3	Electrical characteristics	10
2.4	Electrical characteristics curves	16
2.5	GND protection network against reverse battery	19
2.5.1	Solution 1: resistor in the ground line (RGND only)	19
2.5.2	Solution 2: diode (DGND) in the ground line	20
2.6	Load dump protection	20
2.7	MCU I/Os protection	20
2.8	Open-load detection in Off-state	20
2.9	SO-8 maximum demagnetization energy (VCC = 13.5V)	22
2.10	PPAK/P <sup>2</sup> PAK maximum demagnetization energy (VCC = 13.5V)	23
<b>3</b>	<b>Package and PCB thermal data</b>	<b>24</b>
3.1	SO-8 thermal data	24
3.2	P <sup>2</sup> PAK thermal data	26
3.3	PPAK thermal data	29
<b>4</b>	<b>Package and packing information</b>	<b>32</b>
4.1	ECOPACK <sup>®</sup> packages	32
4.2	SO-8 package information	32
4.3	PENTAWATT mechanical data	34
4.4	P <sup>2</sup> PAK mechanical data	36
4.5	PPAK mechanical data	38
4.6	SO-8 packing information	40
4.7	PENTAWATT packing information	41
4.8	P <sup>2</sup> PAK packing information	41
4.9	PPAK packing information	43

---

5	Revision history .....	45
---	------------------------	----

Obsolete Product(s) - Obsolete Product(s)

## List of tables

Table 1.	Device summary . . . . .	1
Table 2.	Suggested connections for unused and not connected pins . . . . .	7
Table 3.	Absolute maximum ratings . . . . .	8
Table 4.	Thermal data . . . . .	9
Table 5.	Power . . . . .	10
Table 6.	Switching ( $V_{CC} = 13\text{ V}$ ) . . . . .	10
Table 7.	Input pin . . . . .	10
Table 8.	$V_{CC}$ output diode . . . . .	11
Table 9.	Status pin . . . . .	11
Table 10.	Protections . . . . .	11
Table 11.	Open-load detection . . . . .	11
Table 12.	Truth table . . . . .	13
Table 13.	Electrical transient requirements on $V_{CC}$ pin (part 1) . . . . .	14
Table 14.	Electrical transient requirements on $V_{CC}$ pin (part 2) . . . . .	14
Table 15.	Electrical transient requirements on $V_{CC}$ pin (part 3) . . . . .	14
Table 16.	Thermal parameter . . . . .	26
Table 17.	Thermal parameter . . . . .	28
Table 18.	Thermal parameter . . . . .	31
Table 19.	SO-8 mechanical data . . . . .	33
Table 20.	PENTAWATT mechanical data . . . . .	34
Table 21.	P <sup>2</sup> PAK mechanical data . . . . .	37
Table 22.	PPAK mechanical data . . . . .	39
Table 23.	Document revision history . . . . .	45

## List of figures

Figure 1.	Block diagram	7
Figure 2.	Configuration diagram (top view)	7
Figure 3.	Current and voltage conventions	8
Figure 4.	Status timings	12
Figure 5.	Switching time waveforms	12
Figure 6.	Waveforms	15
Figure 7.	Off-state output current	16
Figure 8.	High level input current	16
Figure 9.	Input clamp voltage	16
Figure 10.	Status leakage current	16
Figure 11.	Status low output voltage	16
Figure 12.	Status clamp voltage	16
Figure 13.	On-state resistance vs $T_{case}$	17
Figure 14.	On-state resistance vs $V_{CC}$	17
Figure 15.	Open-load On-state detection threshold	17
Figure 16.	Input high level	17
Figure 17.	Input low level	17
Figure 18.	Input hysteresis voltage	17
Figure 19.	Overshoot shutdown	18
Figure 20.	Open-load Off-state voltage detection threshold	18
Figure 21.	Turn-on voltage slope	18
Figure 22.	Turn-off voltage slope	18
Figure 23.	$I_{lim}$ vs $T_{case}$	18
Figure 24.	Application schematic	19
Figure 25.	Open-load detection in off-state	21
Figure 26.	SO-8 maximum turn-off current versus inductance	22
Figure 27.	PPAK /P <sup>2</sup> PAK maximum turn-off current versus inductance	23
Figure 28.	SO-8 PC board	24
Figure 29.	Rthj-amb vs PCB copper area in open box free air condition	24
Figure 30.	SO-8 thermal impedance junction ambient single pulse	25
Figure 31.	Thermal fitting model of a single channel	25
Figure 32.	P <sup>2</sup> PAK PC board	26
Figure 33.	Rthj-amb vs PCB copper area in open box free air condition	27
Figure 34.	P <sup>2</sup> PAK thermal impedance junction ambient single pulse	27
Figure 35.	Thermal fitting model of a single channel	28
Figure 36.	PPAK PC board	29
Figure 37.	Rthj-amb vs PCB copper area in open box free air condition	29
Figure 38.	PPAK thermal impedance junction ambient single pulse	30
Figure 39.	Thermal fitting model of a single channel	30
Figure 40.	SO-8 package dimensions	32
Figure 41.	PENTAWATT package dimensions	34
Figure 42.	P <sup>2</sup> PAK package dimensions	36
Figure 43.	PPAK package dimensions	38
Figure 44.	SO-8 tube shipment (no suffix)	40
Figure 45.	SO-8 tape and reel shipment (suffix "TR")	40
Figure 46.	PENTAWATT tube shipment (no suffix)	41
Figure 47.	P <sup>2</sup> PAK tube shipment (no suffix)	41
Figure 48.	P <sup>2</sup> PAK tape and reel (suffix "13TR")	42

---

Figure 49. PPAK suggested pad layout . . . . .	43
Figure 50. PPAK tube shipment (no suffix) . . . . .	43
Figure 51. PPAK tape and reel (suffix "13TR") . . . . .	44

Obsolete Product(s) - Obsolete Product(s)

# 1 Block diagram and pin description

Figure 1. Block diagram

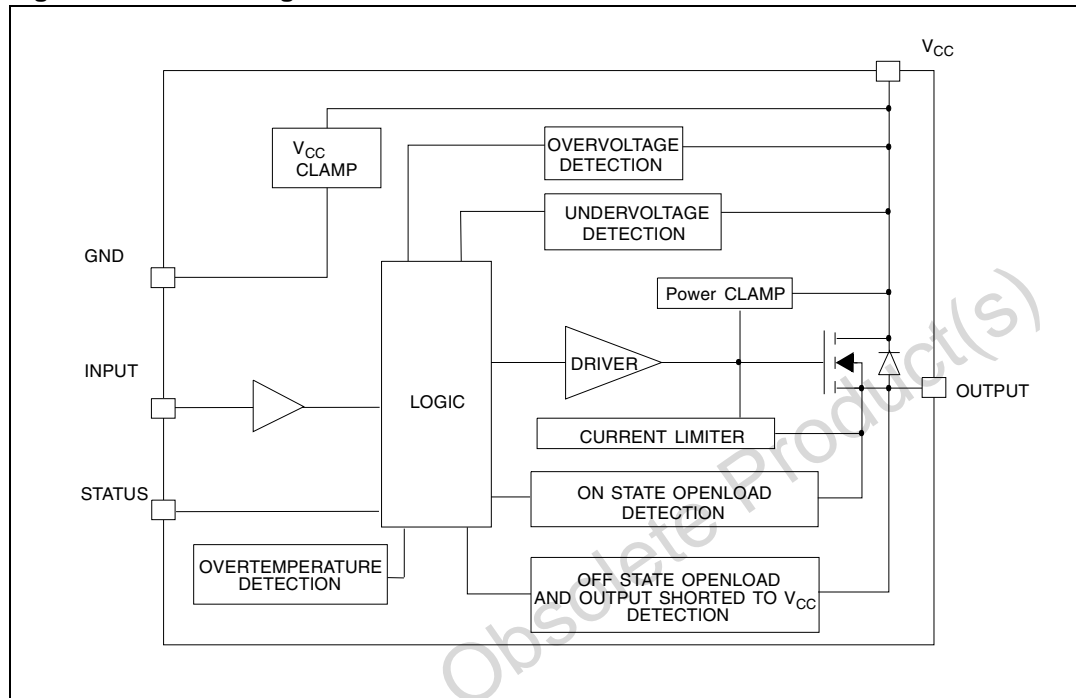

Figure 2. Configuration diagram (top view)

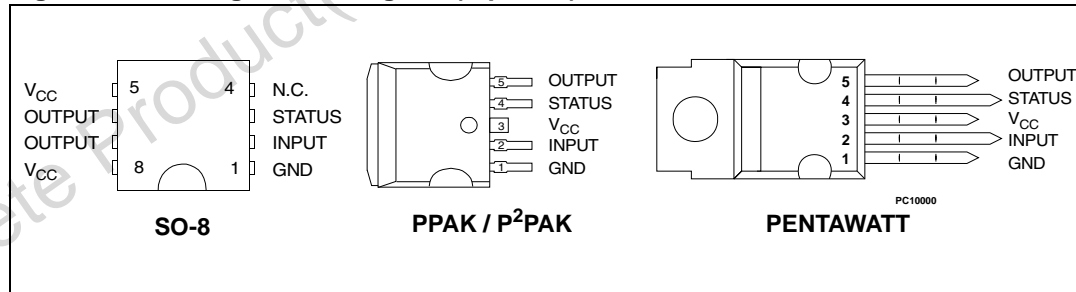
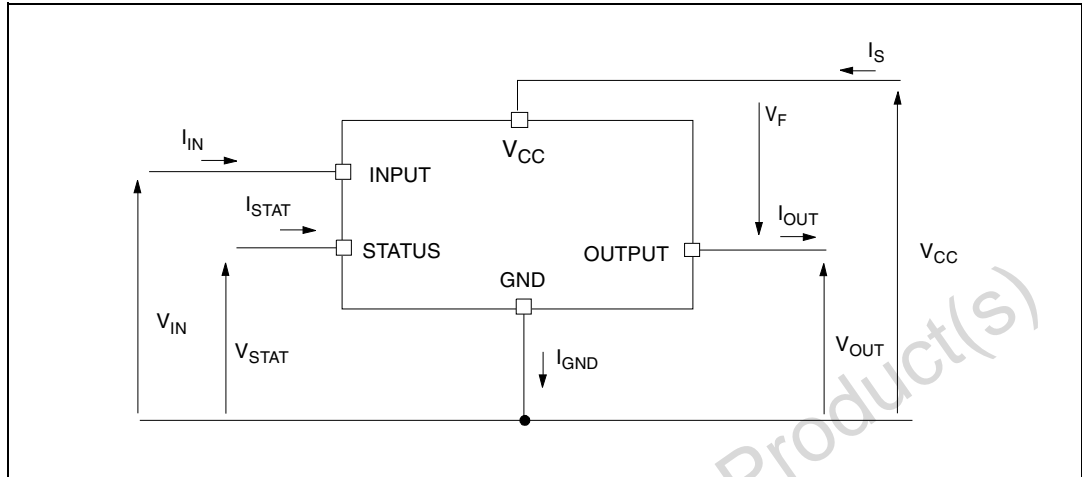

Table 2. Suggested connections for unused and not connected pins

Connection / pin	Status	N.C.	Output	Input
Floating	X	X	X	X
To ground		X		Through 10KΩ resistor

## 2 Electrical specifications

Figure 3. Current and voltage conventions



### 2.1 Absolute maximum ratings

Stressing the device above the rating listed in the [Table 3](#) may cause permanent damage to the device. These are stress ratings only and operation of the device at these or any other conditions above those indicated in the operating sections of this specification is not implied. Exposure to Absolute maximum rating conditions for extended periods may affect device reliability.

Table 3. Absolute maximum ratings

Symbol	Parameter	Value				Unit
		SO-8	PENTAWATT	P <sup>2</sup> PAK	PPAK	
V <sub>CC</sub>	DC supply voltage	41				V
-V <sub>CC</sub>	Reverse DC supply voltage	-0.3				V
-I <sub>gnd</sub>	DC reverse ground pin current	-200				mA
I <sub>OUT</sub>	DC output current	Internally limited				A
-I <sub>OUT</sub>	Reverse DC output current	-6				A
I <sub>IN</sub>	DC input current	+/- 10				mA
I <sub>STAT</sub>	DC Status current	+/- 10				mA
V <sub>ESD</sub>	Electrostatic discharge (human body model: R = 1.5 KΩ; C = 100 pF)					
	- INPUT	4000				V
	- STATUS	4000				V
	- OUTPUT	5000				V
	- V <sub>CC</sub>	5000				V

Table 3. Absolute maximum ratings (continued)

Symbol	Parameter	Value				Unit
		SO-8	PENTAWATT	P <sup>2</sup> PAK	PPAK	
E <sub>MAX</sub>	Maximum switching energy (L = 1.8 mH; R <sub>L</sub> = 0 Ω; V <sub>bat</sub> = 13.5 V; T <sub>jstart</sub> = 150°C; I <sub>L</sub> = 9 A)	100				mJ
E <sub>MAX</sub>	Maximum switching energy (L = 2.46 mH; R <sub>L</sub> = 0 Ω; V <sub>bat</sub> = 13.5 V; T <sub>jstart</sub> = 150°C; I <sub>L</sub> = 9 A)			138	138	mJ
P <sub>tot</sub>	Power dissipation T <sub>C</sub> = 25°C	4.2	60	60	60	W
T <sub>j</sub>	Junction operating temperature	Internally limited				°C
T <sub>c</sub>	Case operating temperature	-40 to 150				°C
T <sub>stg</sub>	Storage temperature	-55 to 150				°C

## 2.2 Thermal data

Table 4. Thermal data

Symbol	Parameter	Max. value				Unit
		SO-8	PENTAWATT	P <sup>2</sup> PAK	PPAK	
R <sub>thj-case</sub>	Thermal resistance junction-case	-	2.1	2.1	2.1	°C/W
R <sub>thj-lead</sub>	Thermal resistance junction-lead	30	-	-	-	°C/W
R <sub>thj-amb</sub>	Thermal resistance junction-ambient	93 <sup>(1)</sup>	62.1	52.1 <sup>(2)</sup>	77.1 <sup>(2)</sup>	°C/W
		82 <sup>(3)</sup>	62.1	37 <sup>(4)</sup>	44 <sup>(4)</sup>	°C/W

1. When mounted on a standard single-sided FR-4 board with 0.5 cm<sup>2</sup> of Cu (at least 35 μm thick) connected to all V<sub>CC</sub> pins. Horizontal mounting and no artificial air flow.
2. When mounted on a standard single-sided FR-4 board with 0.5 cm<sup>2</sup> of Cu (at least 35 μm thick). Horizontal mounting and no artificial air flow.
3. When mounted on a standard single-sided FR-4 board with 2 cm<sup>2</sup> of Cu (at least 35 μm thick) connected to all V<sub>CC</sub> pins. Horizontal mounting and no artificial air flow.
4. When mounted on a standard single-sided FR-4 board with 6 cm<sup>2</sup> of Cu (at least 35 μm thick). Horizontal mounting and no artificial air flow.

## 2.3 Electrical characteristics

Values specified in this section are for  $8\text{ V} < V_{CC} < 36\text{ V}$ ;  $-40^\circ\text{C} < T_j < 150^\circ\text{C}$ , unless otherwise stated.

**Table 5. Power**

Symbol	Parameter	Test conditions	Min.	Typ.	Max.	Unit
$V_{CC}$	Operating supply voltage		5.5	13	36	V
$V_{USD}$	Undervoltage shutdown		3	4	5.5	V
$V_{USDhyst}$	Undervoltage shutdown hysteresis			0.5		V
$V_{OV}$	Overvoltage shutdown		36			V
$R_{ON}$	On state resistance	$I_{OUT} = 2\text{ A}$ ; $T_j = 25^\circ\text{C}$ ; $V_{CC} > 8\text{ V}$			60	m $\Omega$
		$I_{OUT} = 2\text{ A}$ ; $V_{CC} > 8\text{ V}$			120	m $\Omega$
$I_S$	Supply current	Off-state; $V_{CC} = 13\text{ V}$ ; $V_{IN} = V_{OUT} = 0\text{ V}$		10	25	$\mu\text{A}$
		Off-state; $V_{CC} = 13\text{ V}$ ; $V_{IN} = V_{OUT} = 0\text{ V}$ ; $T_j = 25^\circ\text{C}$		10	20	$\mu\text{A}$
		On-state; $V_{CC} = 13\text{ V}$ ; $V_{IN} = 5\text{ V}$ ; $I_{OUT} = 0\text{ A}$		2	3.5	mA
$I_{L(off1)}$	Off-state output current	$V_{IN} = V_{OUT} = 0\text{ V}$	0		50	$\mu\text{A}$
$I_{L(off2)}$	Off-state output current	$V_{IN} = 0\text{ V}$ ; $V_{OUT} = 3.5\text{ V}$	-75		0	$\mu\text{A}$
$I_{L(off3)}$	Off-state output current	$V_{IN} = V_{OUT} = 0\text{ V}$ ; $V_{CC} = 13\text{ V}$ ; $T_j = 125^\circ\text{C}$			5	$\mu\text{A}$
$I_{L(off4)}$	Off-state output current	$V_{IN} = V_{OUT} = 0\text{ V}$ ; $V_{CC} = 13\text{ V}$ ; $T_j = 25^\circ\text{C}$			3	$\mu\text{A}$

**Table 6. Switching ( $V_{CC} = 13\text{ V}$ )**

Symbol	Parameter	Test conditions	Min.	Typ.	Max.	Unit
$t_{d(on)}$	Turn-on delay time	$R_L = 6.5\ \Omega$ from $V_{IN}$ rising edge to $V_{OUT} = 1.3\text{ V}$		40		$\mu\text{s}$
$t_{d(off)}$	Turn-off delay time	$R_L = 6.5\ \Omega$ from $V_{IN}$ falling edge to $V_{OUT} = 11.7\text{ V}$		30		$\mu\text{s}$
$dV_{OUT}/dt_{(on)}$	Turn-on voltage slope	$R_L = 6.5\ \Omega$ from $V_{OUT} = 1.3\text{ V}$ to $V_{OUT} = 10.4\text{ V}$	See <a href="#">Figure 21</a>			V/ $\mu\text{s}$
$dV_{OUT}/dt_{(off)}$	Turn-off voltage slope	$R_L = 6.5\ \Omega$ from $V_{OUT} = 11.7\text{ V}$ to $V_{OUT} = 1.3\text{ V}$	See <a href="#">Figure 22</a>			V/ $\mu\text{s}$

**Table 7. Input pin**

Symbol	Parameter	Test conditions	Min.	Typ.	Max.	Unit
$V_{IL}$	Input low level				1.25	V
$I_{IL}$	Low level input current	$V_{IN} = 1.25\text{ V}$	1			$\mu\text{A}$
$V_{IH}$	Input high level		3.25			V

Table 7. Input pin (continued)

Symbol	Parameter	Test conditions	Min.	Typ.	Max.	Unit
$I_{IH}$	High level input current	$V_{IN} = 3.25\text{ V}$			10	$\mu\text{A}$
$V_{hyst}$	Input hysteresis voltage		0.5			V
$V_{ICL}$	Input clamp voltage	$I_{IN} = 1\text{ mA}$	6	6.8	8	V
		$I_{IN} = -1\text{ mA}$		-0.7		V

Table 8.  $V_{CC}$  output diode

Symbol	Parameter	Test conditions	Min.	Typ.	Max.	Unit
$V_F$	Forward on voltage	$-I_{OUT} = 1.3\text{ A}; T_j = 150^\circ\text{C}$	—	—	0.6	V

Table 9. Status pin

Symbol	Parameter	Test conditions	Min.	Typ.	Max.	Unit
$V_{STAT}$	Status low output voltage	$I_{STAT} = 1.6\text{ mA}$			0.5	V
$I_{LSTAT}$	Status leakage current	Normal operation; $V_{STAT} = 5\text{ V}$			10	$\mu\text{A}$
$C_{STAT}$	Status pin input capacitance	Normal operation; $V_{STAT} = 5\text{ V}$			100	pF
$V_{SCL}$	Status clamp voltage	$I_{STAT} = 1\text{ mA}$	6	6.8	8	V
		$I_{STAT} = -1\text{ mA}$		-0.7		V

Table 10. Protections<sup>(1)</sup>

Symbol	Parameter	Test conditions	Min.	Typ.	Max.	Unit
$T_{TSD}$	Shutdown temperature		150	175	200	$^\circ\text{C}$
$T_R$	Reset temperature		135			$^\circ\text{C}$
$T_{hyst}$	Thermal hysteresis		7	15		$^\circ\text{C}$
$t_{SDL}$	Status delay in overload condition	$T_j > T_{jsh}$			20	ms
$I_{lim}$	Current limitation	$9\text{ V} < V_{CC} < 36\text{ V}$	6	9	15	A
		$5\text{ V} < V_{CC} < 36\text{ V}$			15	A
$V_{demag}$	Turn-off output clamp voltage	$I_{OUT} = 2\text{ A}; V_{IN} = 0\text{ V}; L = 6\text{ mH}$	$V_{CC} - 41$	$V_{CC} - 48$	$V_{CC} - 55$	V

1. To ensure long term reliability under heavy overload or short circuit conditions, protection and related diagnostic signals must be used together with a proper software strategy. If the device operates under abnormal conditions this software must limit the duration and number of activation cycles.

Table 11. Open-load detection

Symbol	Parameter	Test conditions	Min.	Typ.	Max.	Unit
$I_{OL}$	Open-load ON-state detection threshold	$V_{IN} = 5\text{ V}$	50		200	mA
$t_{DOL(on)}$	Open-load ON-state detection delay	$I_{OUT} = 0\text{ A}$			200	$\mu\text{s}$

**Table 11. Open-load detection (continued)**

Symbol	Parameter	Test conditions	Min.	Typ.	Max.	Unit
$V_{OL}$	Open-load OFF-state voltage detection threshold	$V_{IN} = 0\text{ V}$	1.5		3.5	V
$t_{DOL(off)}$	Open-load detection delay at turn-off				1000	$\mu\text{s}$

**Figure 4. Status timings**

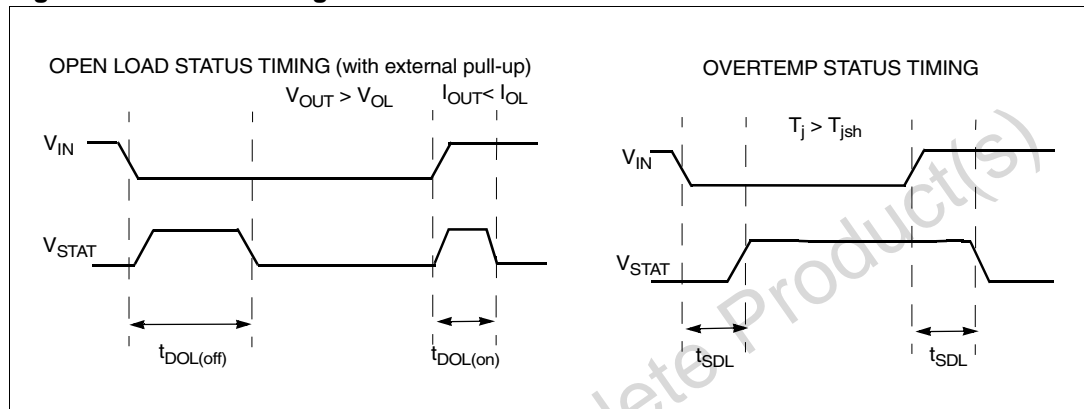

**Figure 5. Switching time waveforms**

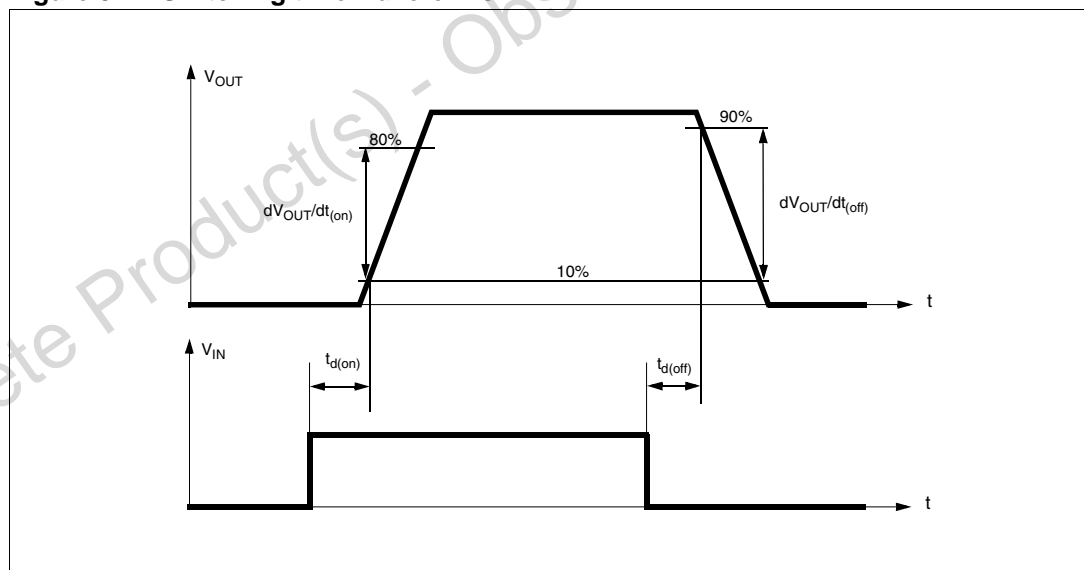

Table 12. Truth table

Conditions	Input	Output	Status
Normal operation	L	L	H
	H	H	H
Current limitation	L	L	H
	H	X	$(T_j < T_{TSD})$ H
	H	X	$(T_j > T_{TSD})$ L
Overtemperature	L	L	H
	H	L	L
Undervoltage	L	L	X
	H	L	X
Overvoltage	L	L	H
	H	L	H
Output voltage > $V_{OL}$	L	H	L
	H	H	H
Output current < $I_{OL}$	L	L	H
	H	H	L

**Table 13. Electrical transient requirements on V<sub>CC</sub> pin (part 1)**

ISO T/R 7637/1 Test pulse	Test levels				Delays and impedance
	I	II	III	IV	
1	- 25 V	- 50 V	- 75 V	- 100 V	2 ms 10 Ω
2	+ 25 V	+ 50 V	+ 75 V	+ 100 V	0.2 ms 10 Ω
3a	- 25 V	- 50 V	- 100 V	- 150 V	0.1 μs 50 Ω
3b	+ 25 V	+ 50 V	+ 75 V	+ 100 V	0.1 μs 50 Ω
4	- 4 V	- 5 V	- 6 V	- 7 V	100 ms, 0.01 Ω
5	+ 26.5 V	+ 46.5 V	+ 66.5 V	+ 86.5 V	400 ms, 2 Ω

**Table 14. Electrical transient requirements on V<sub>CC</sub> pin (part 2)**

ISO T/R 7637/1 test pulse	Test levels results			
	I	II	III	IV
1	C	C	C	C
2	C	C	C	C
3a	C	C	C	C
3b	C	C	C	C
4	C	C	C	C
5	C	E	E	E

**Table 15. Electrical transient requirements on V<sub>CC</sub> pin (part 3)**

Class	Contents
C	All functions of the device are performed as designed after exposure to disturbance.
E	One or more functions of the device is not performed as designed after exposure to disturbance and cannot be returned to proper operation without replacing the device.

Figure 6. Waveforms

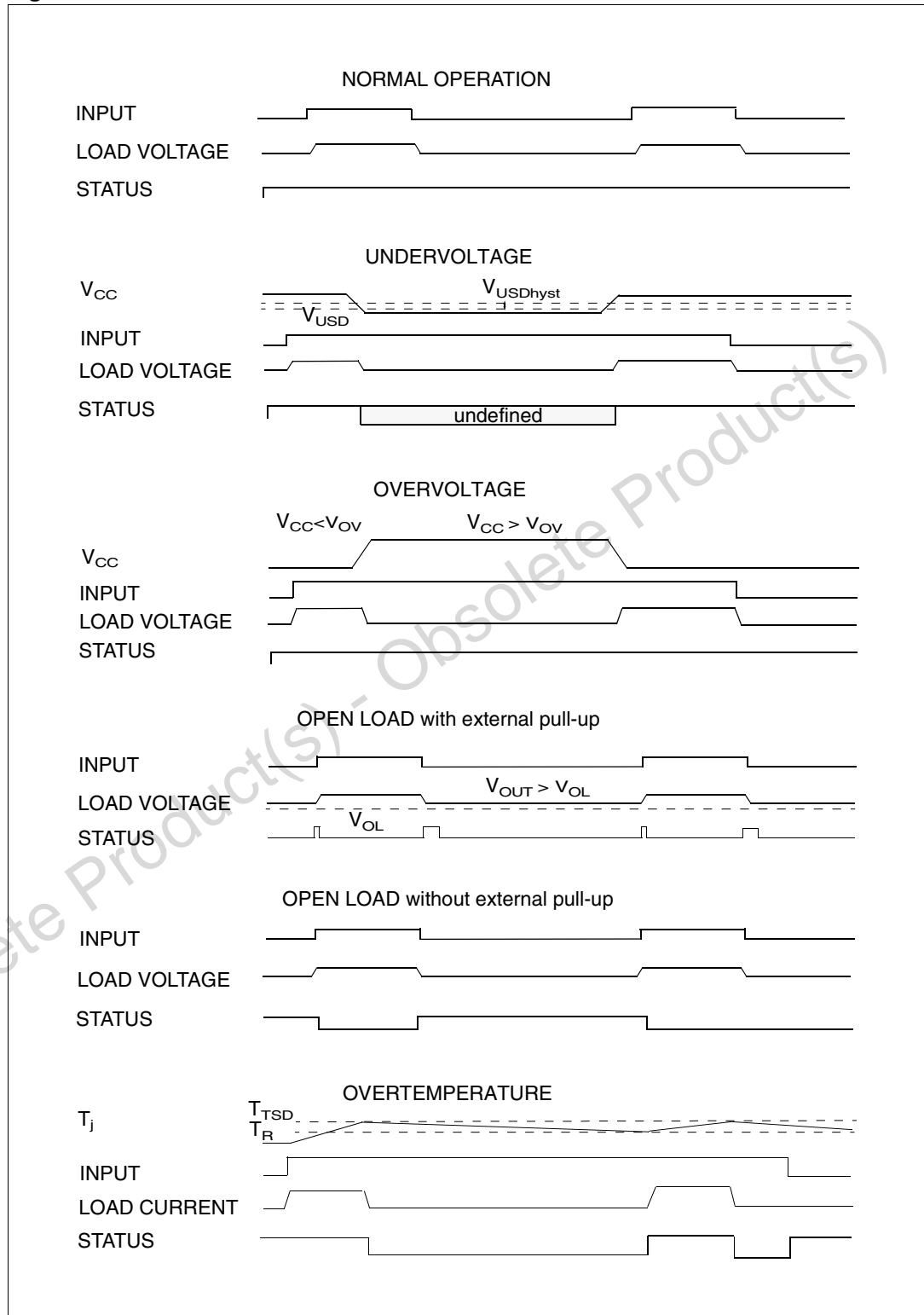

## 2.4 Electrical characteristics curves

Figure 7. Off-state output current

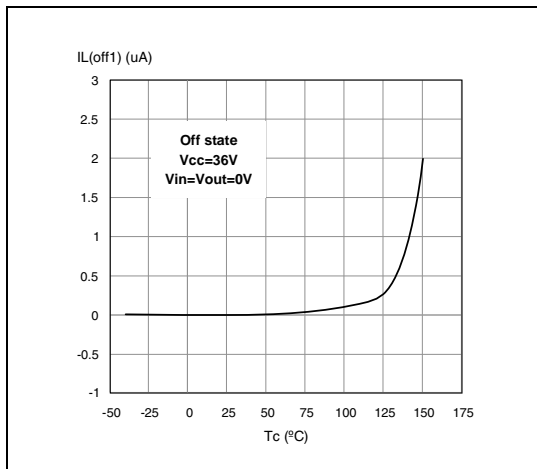

Figure 8. High level input current

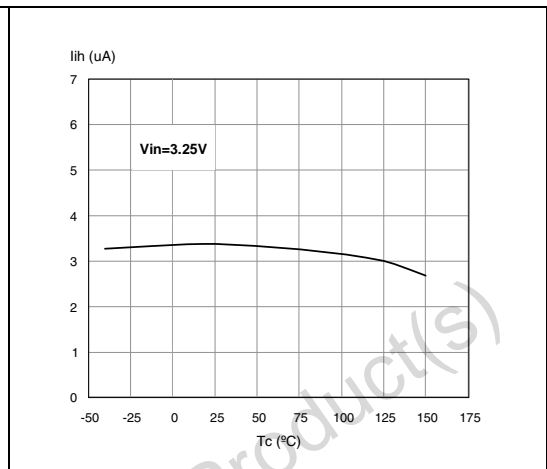

Figure 9. Input clamp voltage

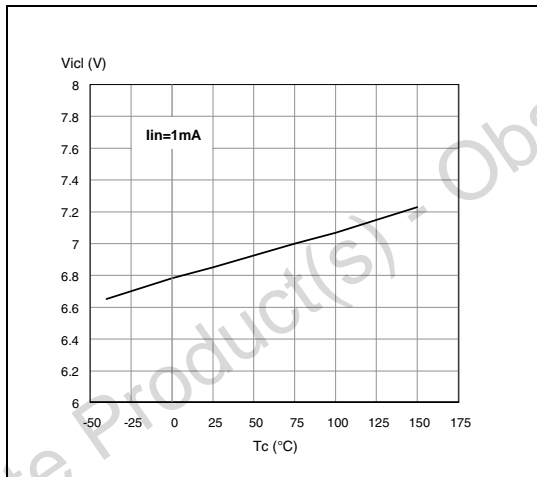

Figure 10. Status leakage current

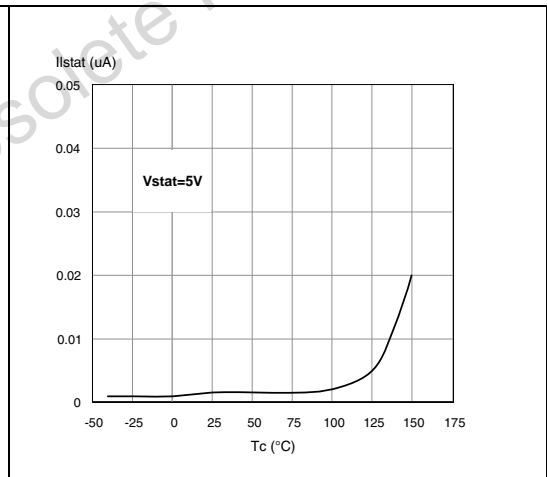

Figure 11. Status low output voltage

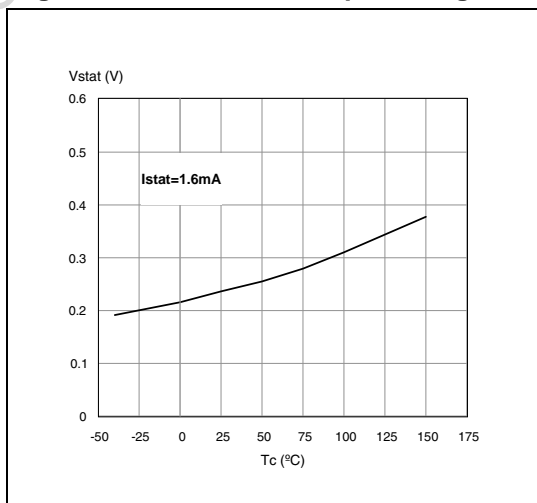

Figure 12. Status clamp voltage

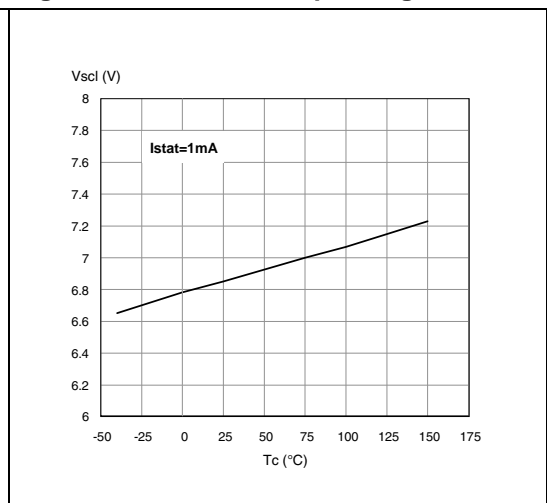

Figure 13. On-state resistance vs  $T_{case}$

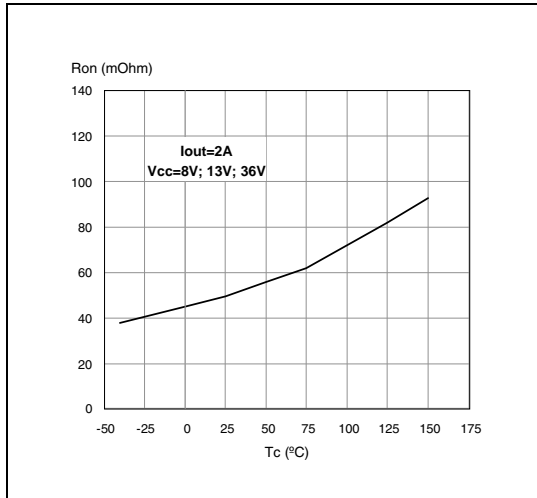

Figure 14. On-state resistance vs  $V_{CC}$

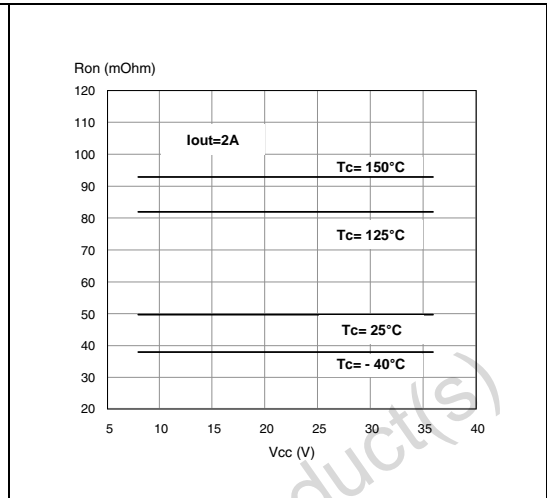

Figure 15. Open-load On-state detection

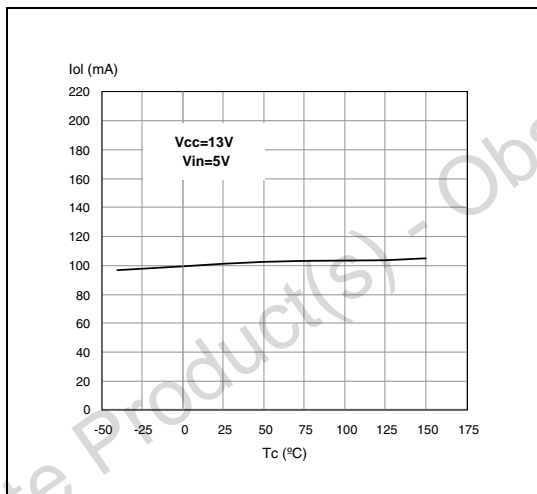

Figure 16. Input high level threshold

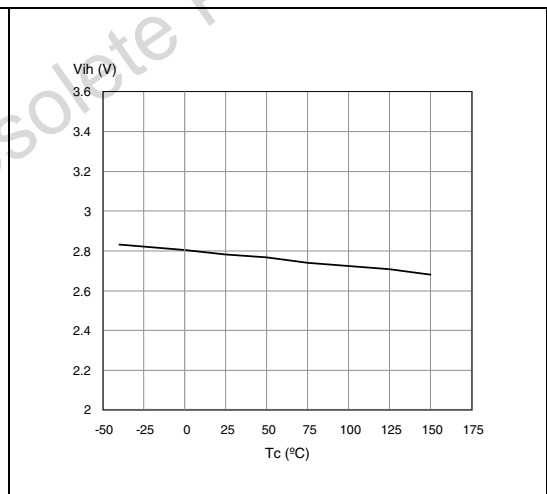

Figure 17. Input low level

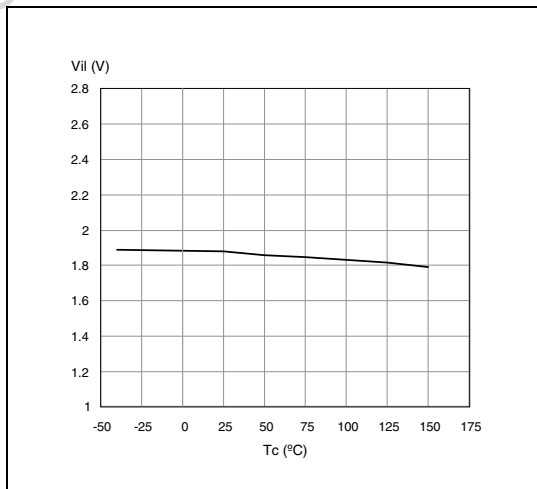

Figure 18. Input hysteresis voltage

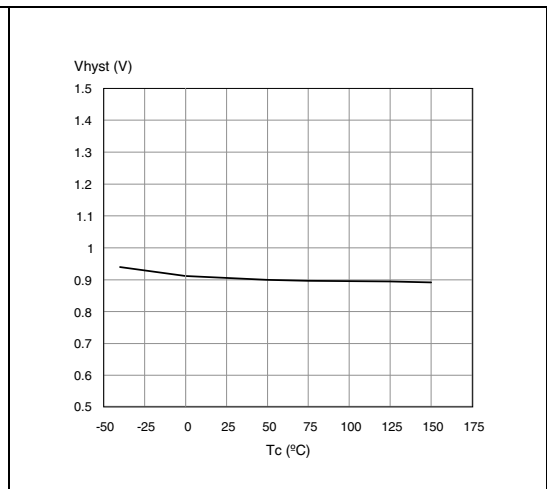

Figure 19. Overtoltage shutdown

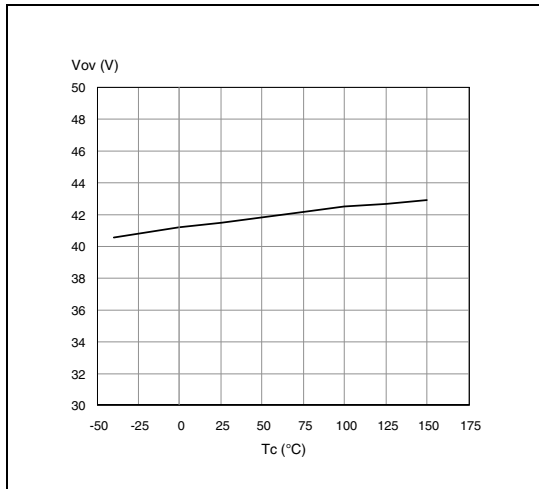

Figure 20. Open-load Off-state voltage detection threshold

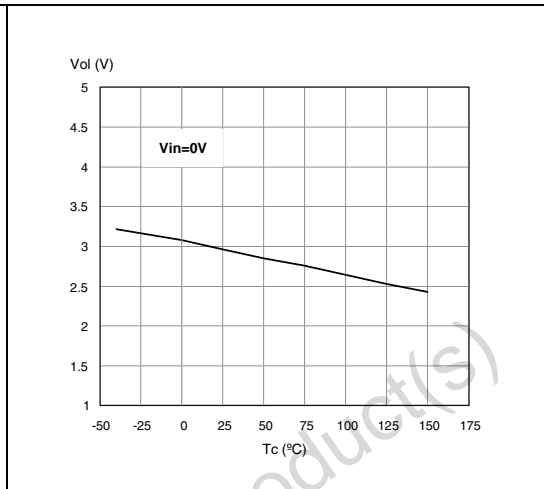

Figure 21. Turn-on voltage slope

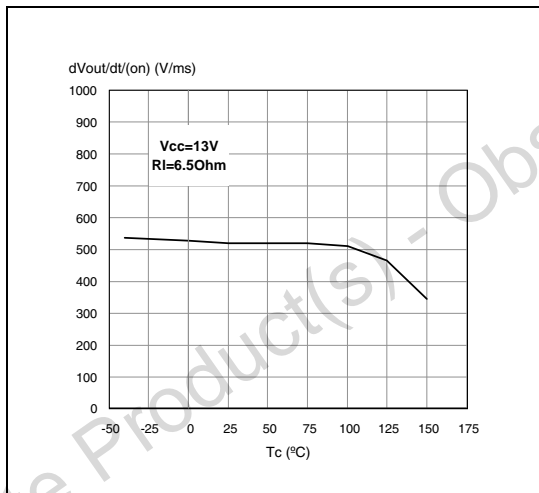

Figure 22. Turn-off voltage slope

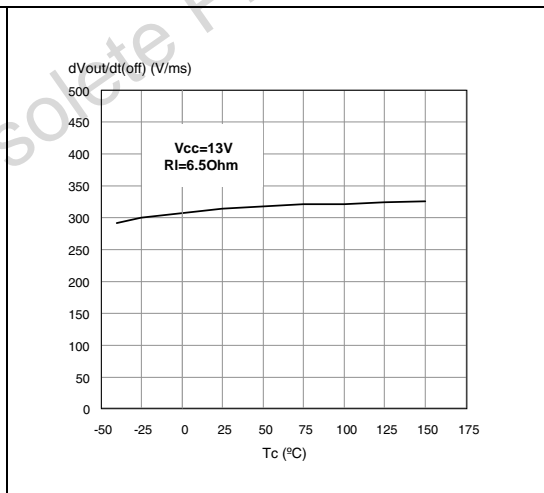

Figure 23. Ilim vs Tcase

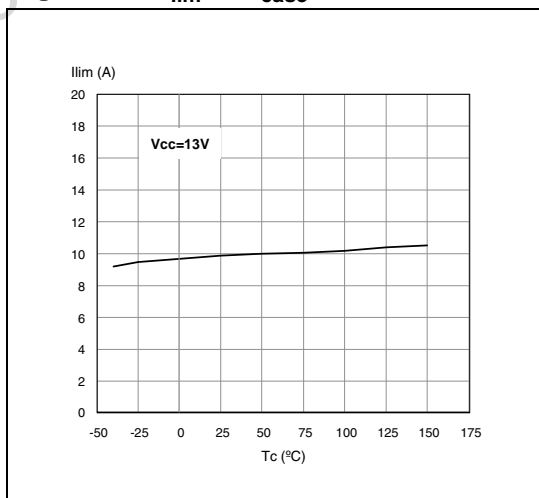
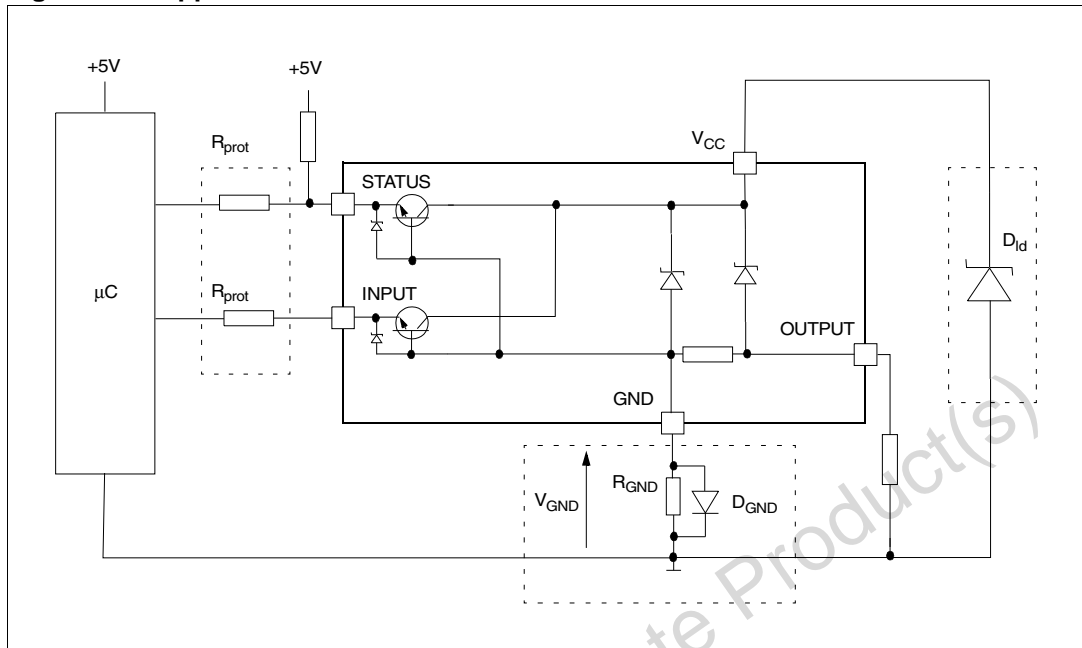

Figure 24. Application schematic



## 2.5 GND protection network against reverse battery

### 2.5.1 Solution 1: resistor in the ground line ( $R_{GND}$ only)

This can be used with any type of load.

The following is an indication on how to size the  $R_{GND}$  resistor.

1.  $R_{GND} \leq 600 \text{ mV} / (I_{S(on)max})$ .
2.  $R_{GND} \geq (-V_{CC}) / (-I_{GND})$

where  $-I_{GND}$  is the DC reverse ground pin current and can be found in the absolute maximum rating section of the device datasheet.

Power dissipation in  $R_{GND}$  (when  $V_{CC} < 0$ : during reverse battery situations) is:

$$P_D = (-V_{CC})^2 / R_{GND}$$

This resistor can be shared amongst several different HSDs. Please note that the value of this resistor should be calculated with formula (1) where  $I_{S(on)max}$  becomes the sum of the maximum on-state currents of the different devices.

Please note that if the microprocessor ground is not shared by the device ground then the  $R_{GND}$  produces a shift ( $I_{S(on)max} * R_{GND}$ ) in the input thresholds and the status output values. This shift varies depending on how many devices are ON in case of several high side drivers sharing the same  $R_{GND}$ .

If the calculated power dissipation leads to a large resistor or several devices have to share the same resistor then ST suggests to utilize Solution 2 (see below).

### 2.5.2 Solution 2: diode ( $D_{GND}$ ) in the ground line

A resistor ( $R_{GND} = 1 \text{ k}\Omega$ ) should be inserted in parallel to  $D_{GND}$  if the device drives an inductive load.

This small signal diode can be safely shared amongst several different HSDs. Also in this case, the presence of the ground network produces a shift ( $\approx 600 \text{ mV}$ ) in the input threshold and in the status output values if the microprocessor ground is not common to the device ground. This shift does not vary if more than one HSD shares the same diode/resistor network.

Series resistor in INPUT and STATUS lines are also required to prevent that, during battery voltage transient, the current exceeds the absolute maximum rating.

The safest configuration for unused INPUT and STATUS pin is to leave them unconnected.

## 2.6 Load dump protection

$D_{ld}$  is necessary (voltage transient suppressor) if the load dump peak voltage exceeds the  $V_{CC}$  max DC rating. The same applies if the device is subject to transients on the  $V_{CC}$  line that are greater than the ones shown in the ISO 7637-2: 2004(E) table.

## 2.7 MCU I/Os protection

If a ground protection network is used and negative transient are present on the  $V_{CC}$  line, the control pins are pulled negative. ST suggests to insert a resistor ( $R_{prot}$ ) in line to prevent the microcontroller I/O pins from latching-up.

The value of these resistors is a compromise between the leakage current of microcontroller and the current required by the HSD I/Os (Input levels compatibility) with the latch-up limit of microcontroller I/Os.

$$-V_{CCpeak}/I_{latchup} \leq R_{prot} \leq (V_{OH\mu C} - V_{IH} - V_{GND}) / I_{IHmax}$$

Calculation example:

For  $V_{CCpeak} = -100\text{V}$  and  $I_{latchup} \geq 20\text{mA}$ ;  $V_{OH\mu C} \geq 4.5\text{V}$

$$5\text{k}\Omega \leq R_{prot} \leq 65\text{k}\Omega$$

Recommended values:  $R_{prot} = 10\text{k}\Omega$ .

## 2.8 Open-load detection in Off-state

Off-state open-load detection requires an external pull-up resistor ( $R_{PU}$ ) connected between OUTPUT pin and a positive supply voltage ( $V_{PU}$ ) like the +5V line used to supply the microprocessor.

The external resistor has to be selected according to the following requirements:

1. No false open-load indication when load is connected: in this case we have to avoid  $V_{OUT}$  to be higher than  $V_{Omin}$ ; this results in the following condition  $V_{OUT} = (V_{PU} / (R_L + R_{PU})) R_L < V_{Omin}$ .
2. No misdetection when load is disconnected: in this case the  $V_{OUT}$  has to be higher than  $V_{OLmax}$ ; this results in the following condition  $R_{PU} < (V_{PU} - V_{OLmax}) / I_{L(off2)}$ .

Because  $I_{s(OFF)}$  may significantly increase if  $V_{out}$  is pulled high (up to several mA), the pull-up resistor  $R_{PU}$  should be connected to a supply that is switched OFF when the module is in standby.

The values of  $V_{OLmin}$ ,  $V_{OLmax}$  and  $I_{L(off2)}$  are available in the electrical characteristics section.

Figure 25. Open-load detection in off-state

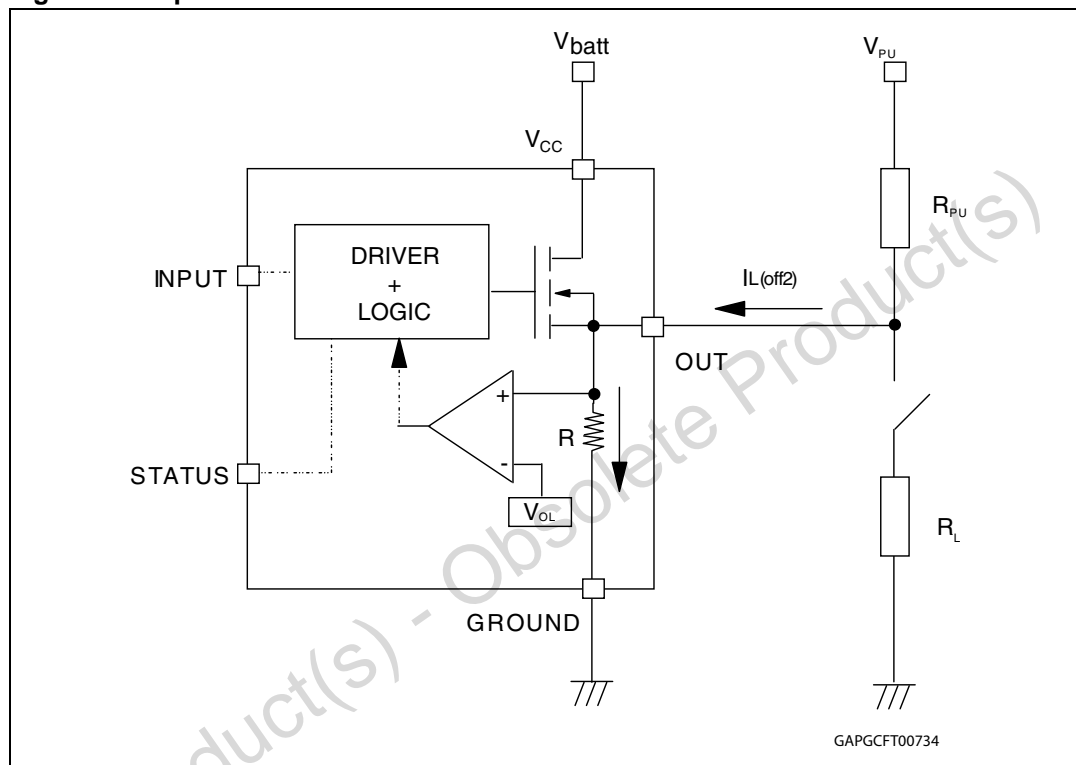

## 2.9 SO-8 maximum demagnetization energy ( $V_{CC} = 13.5V$ )

Figure 26. SO-8 maximum turn-off current versus inductance

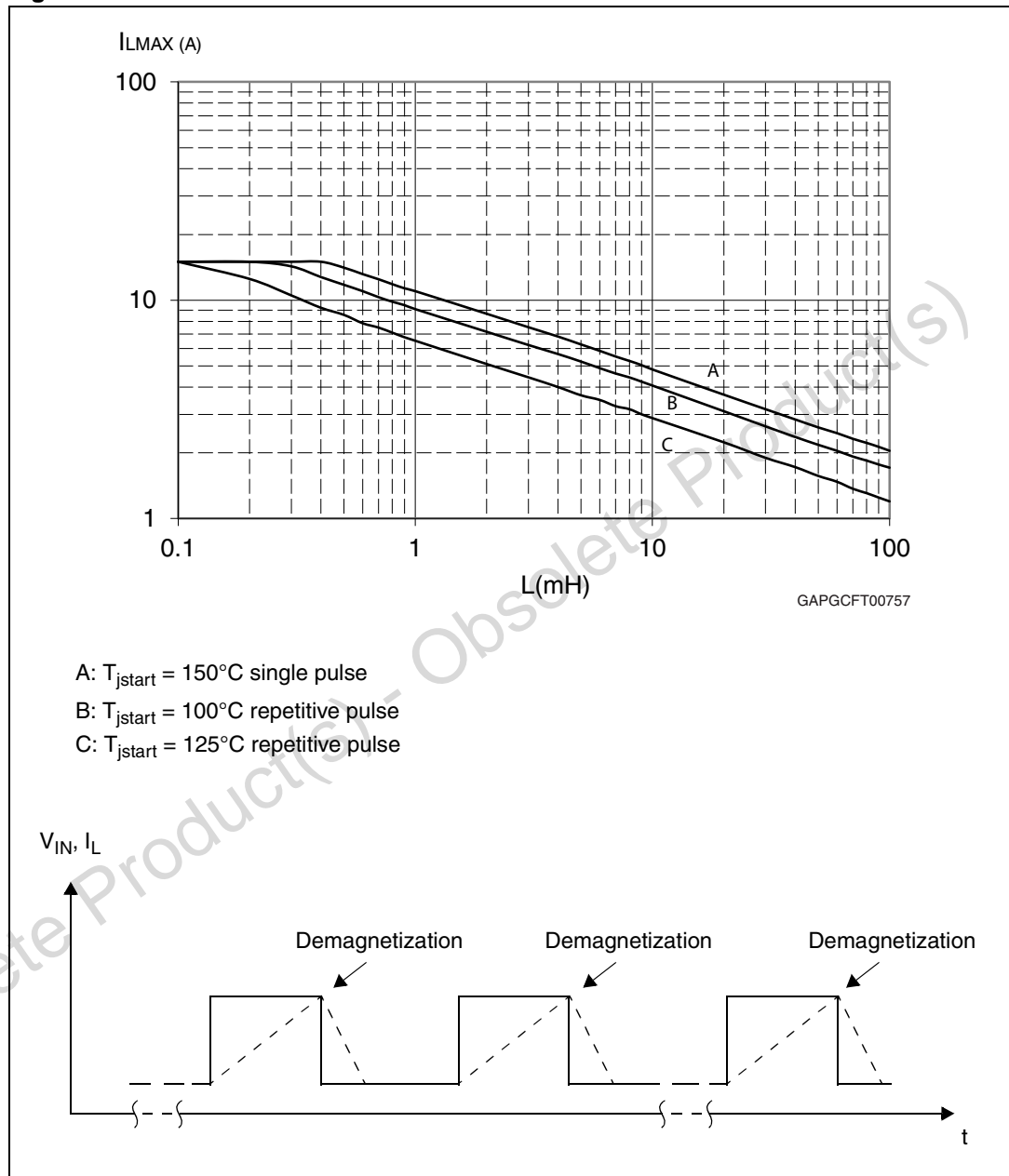

1. Values are generated with  $R_L = 0 \Omega$ . In case of repetitive pulses,  $T_{jstart}$  (at the beginning of each demagnetization) of every pulse must not exceed the temperature specified above for curves A and B.

## 2.10 PPAK/P<sup>2</sup>PAK maximum demagnetization energy ( $V_{CC} = 13.5V$ )

Figure 27. PPAK /P<sup>2</sup>PAK maximum turn-off current versus inductance

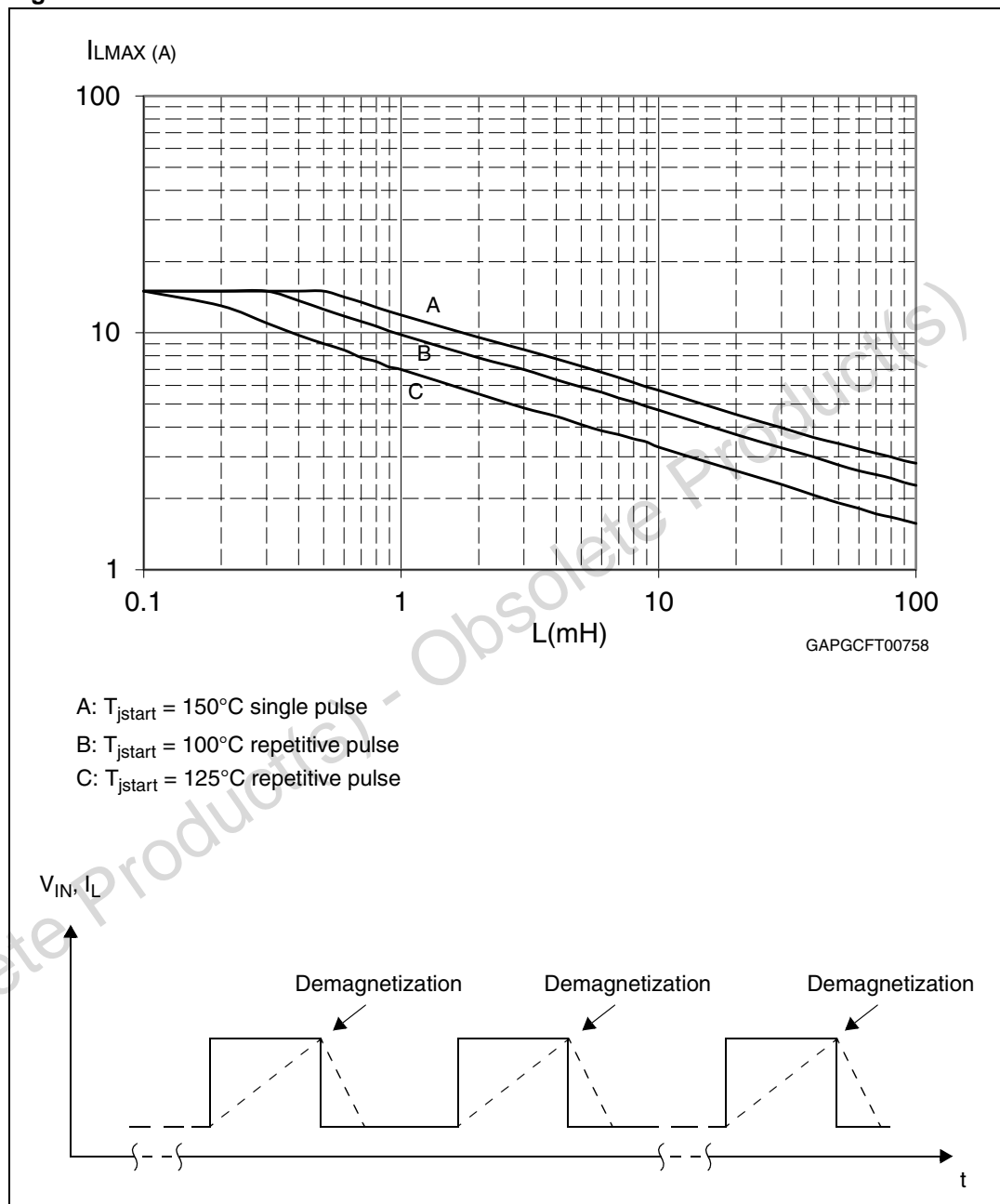

1. Values are generated with  $R_L = 0 \Omega$ . In case of repetitive pulses,  $T_{jstart}$  (at the beginning of each demagnetization) of every pulse must not exceed the temperature specified above for curves A and B.

### 3 Package and PCB thermal data

#### 3.1 SO-8 thermal data

Figure 28. SO-8 PC board

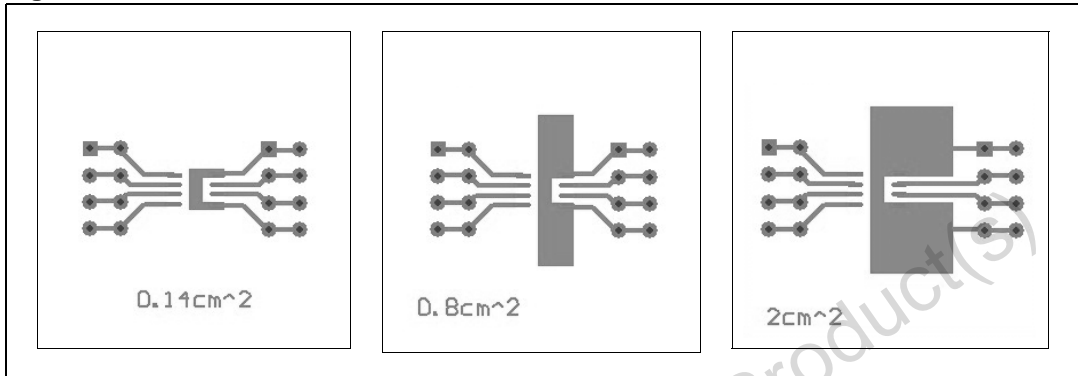

1. Layout condition of  $R_{th}$  and  $Z_{th}$  measurements (PCB FR4 area = 58 mm x 58 mm, PCB thickness = 2 mm, Cu thickness = 35  $\mu\text{m}$ , Copper areas: 0.14  $\text{cm}^2$ , 0.8  $\text{cm}^2$ , 2  $\text{cm}^2$ ).

Figure 29.  $R_{thj-amb}$  vs PCB copper area in open box free air condition

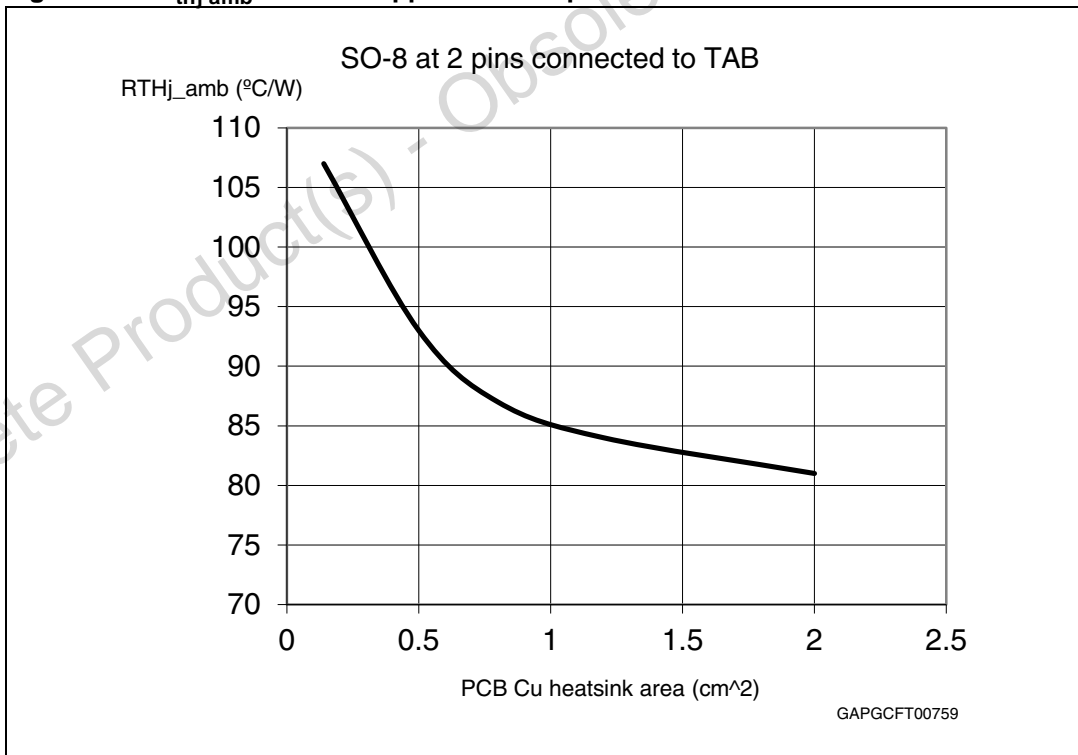
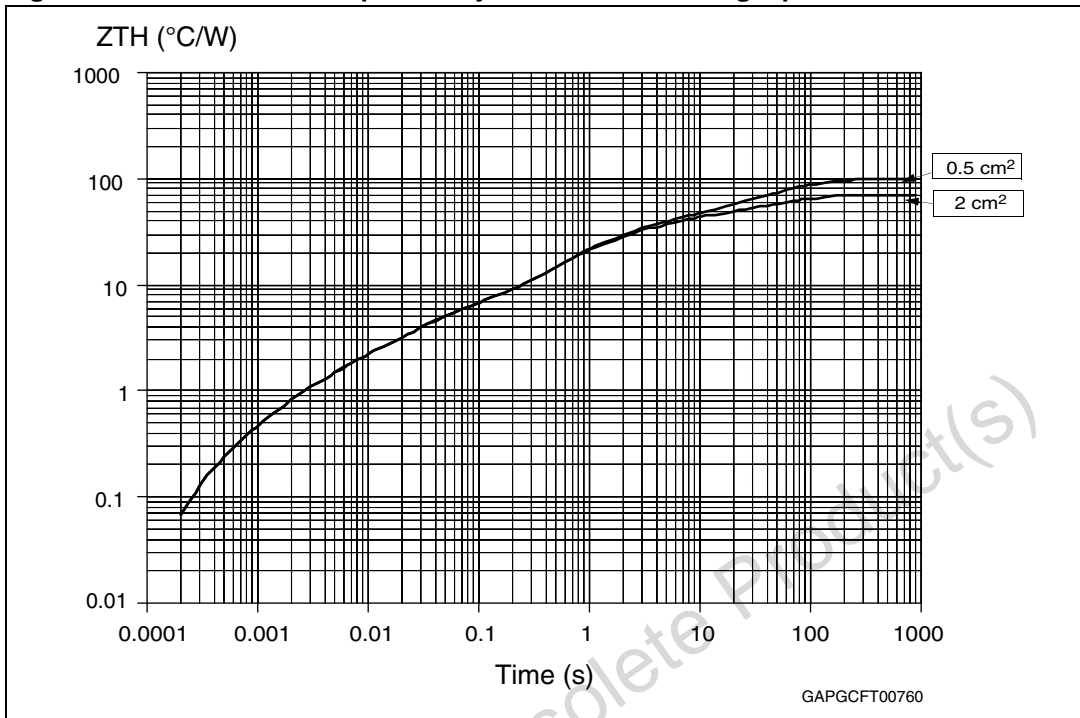

Figure 30. SO-8 thermal impedance junction ambient single pulse



Equation 1: pulse calculation formula

$$Z_{TH\delta} = R_{TH} \cdot \delta + Z_{THtp}(1 - \delta)$$

where  $\delta = t_p/T$

Figure 31. Thermal fitting model of a single channel

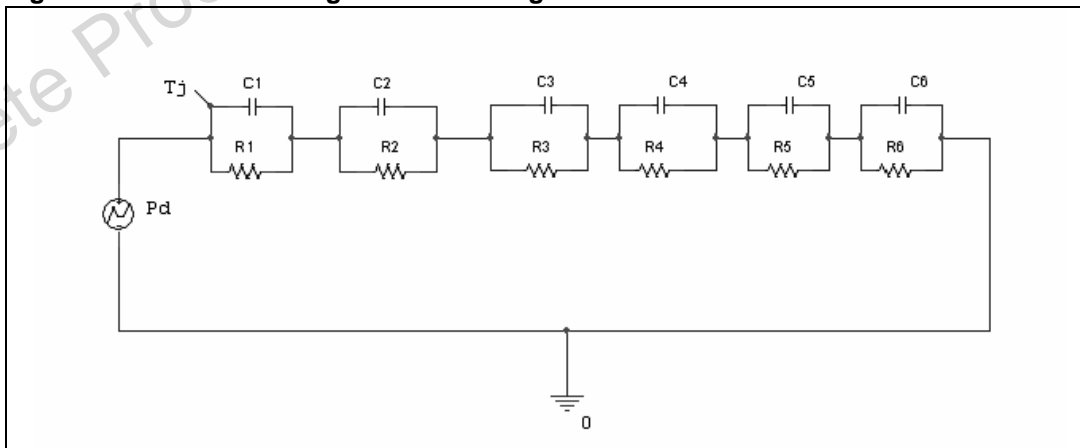
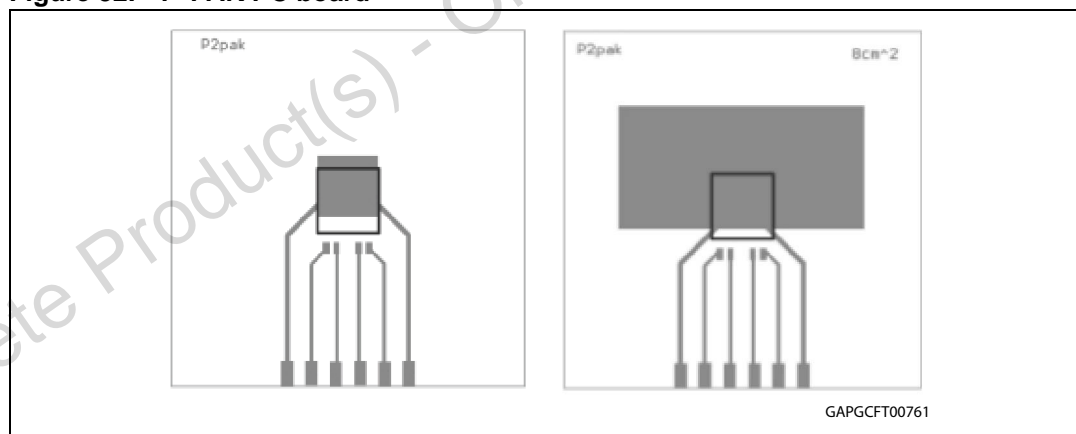

Table 16. Thermal parameter

Area/island (cm <sup>2</sup> )	0.5	2
R1 (°C/W)	0.05	
R2 (°C/W)	0.8	
R3 (°C/W)	3.5	
R4 (°C/W)	21	
R5 (°C/W)	16	
R6 (°C/W)	58	28
C1 (W·s/°C)	0.006	
C2 (W·s/°C)	0.0026	
C3 (W·s/°C)	0.0075	
C4 (W·s/°C)	0.045	
C5 (W·s/°C)	0.35	
C6 (W·s/°C)	1.05	2

### 3.2 P<sup>2</sup>PAK thermal data

Figure 32. P<sup>2</sup>PAK PC board



1. Layout condition of R<sub>th</sub> and Z<sub>th</sub> measurements (PCB FR4 area = 60 mm x 60 mm, PCB thickness = 2 mm, Cu thickness = 35 μm, Copper areas: 0.97 cm<sup>2</sup>, 8 cm<sup>2</sup>).

Figure 33.  $R_{thj-amb}$  vs PCB copper area in open box free air condition

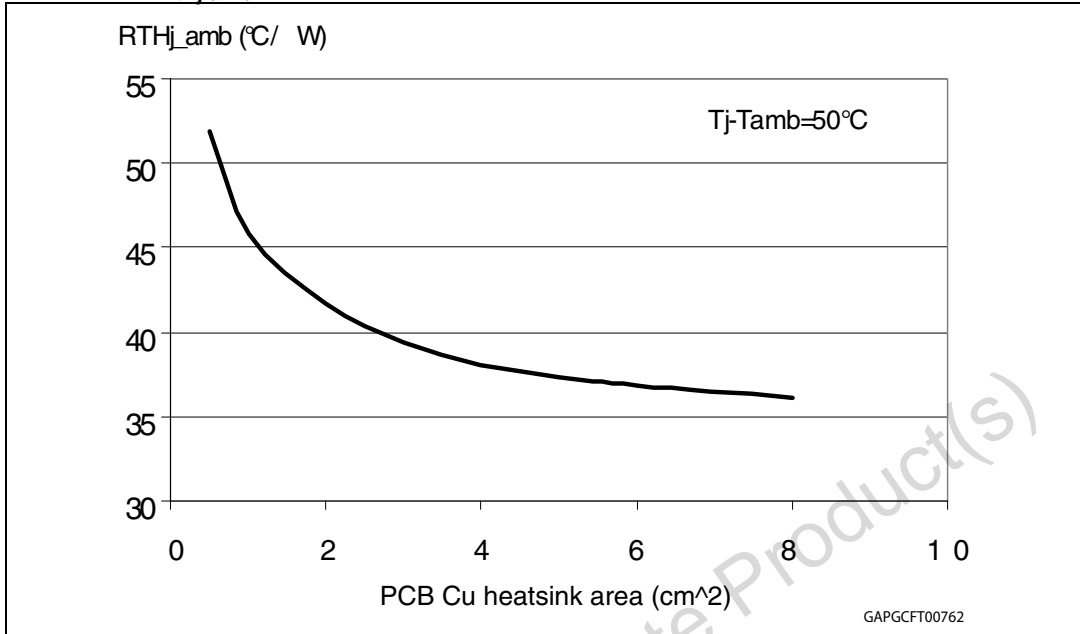
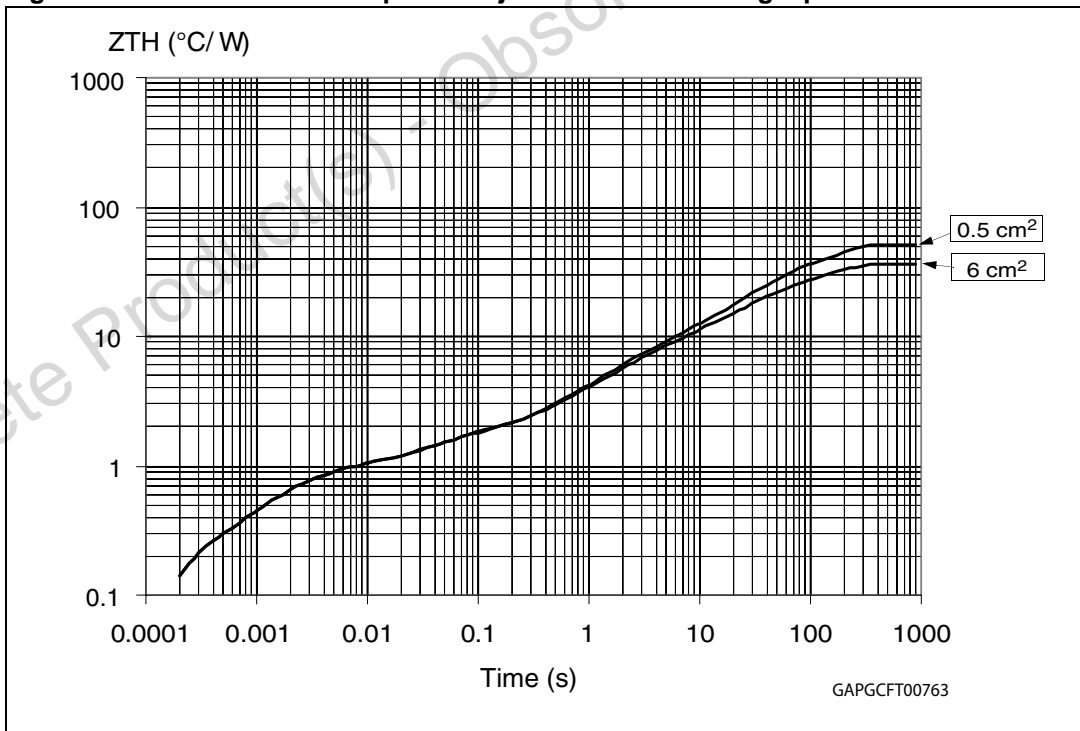

Figure 34. P<sup>2</sup>PAK thermal impedance junction ambient single pulse



Equation 2: pulse calculation formula

$$Z_{TH\delta} = R_{TH} \cdot \delta + Z_{THtp}(1 - \delta)$$

where  $\delta = t_p/T$

Figure 35. Thermal fitting model of a single channel

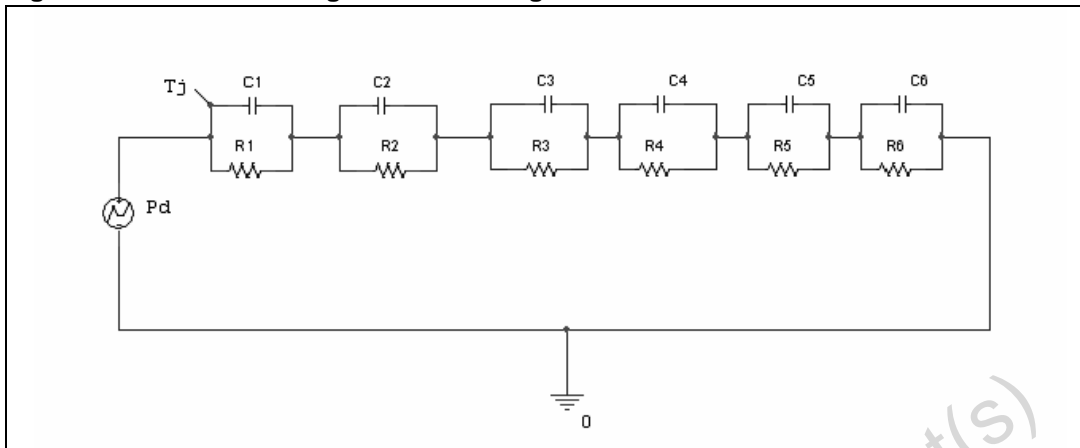
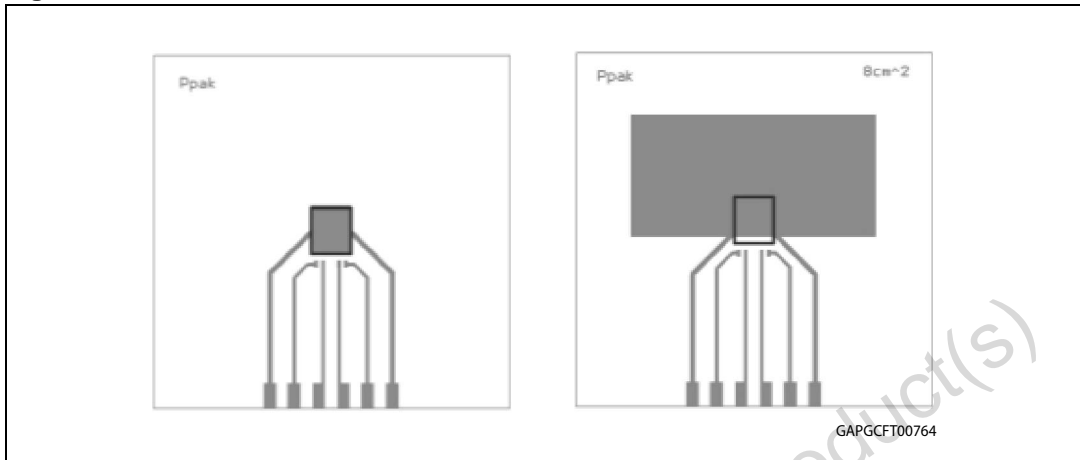

Table 17. Thermal parameter

Area/island (cm <sup>2</sup> )	0.5	6
R1 (°C/W)	0.15	
R2 (°C/W)	0.7	
R3 (°C/W)	0.7	
R4 (°C/W)	4	
R5 (°C/W)	9	
R6 (°C/W)	37	22
C1 (W·s/°C)	0.0006	
C2 (W·s/°C)	0.0025	
C3 (W·s/°C)	0.055	
C4 (W·s/°C)	0.4	
C5 (W·s/°C)	2	
C6 (W·s/°C)	3	5

### 3.3 PPAK thermal data

Figure 36. PPAK PC board



1. Layout condition of  $R_{th}$  and  $Z_{th}$  measurements (PCB FR4 area = 60 mm x 60 mm, PCB thickness = 2 mm, Cu thickness = 35  $\mu$ m, Copper areas: 0.44 cm<sup>2</sup>, 8 cm<sup>2</sup>).

Figure 37.  $R_{thj-amb}$  vs PCB copper area in open box free air condition

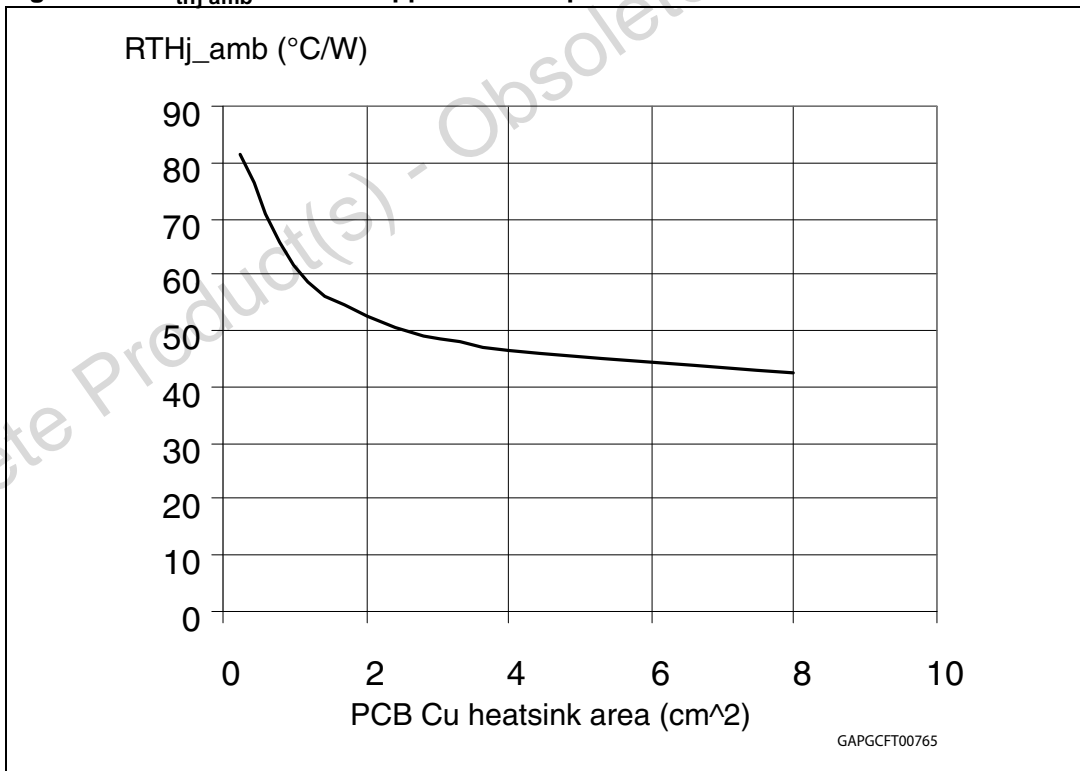
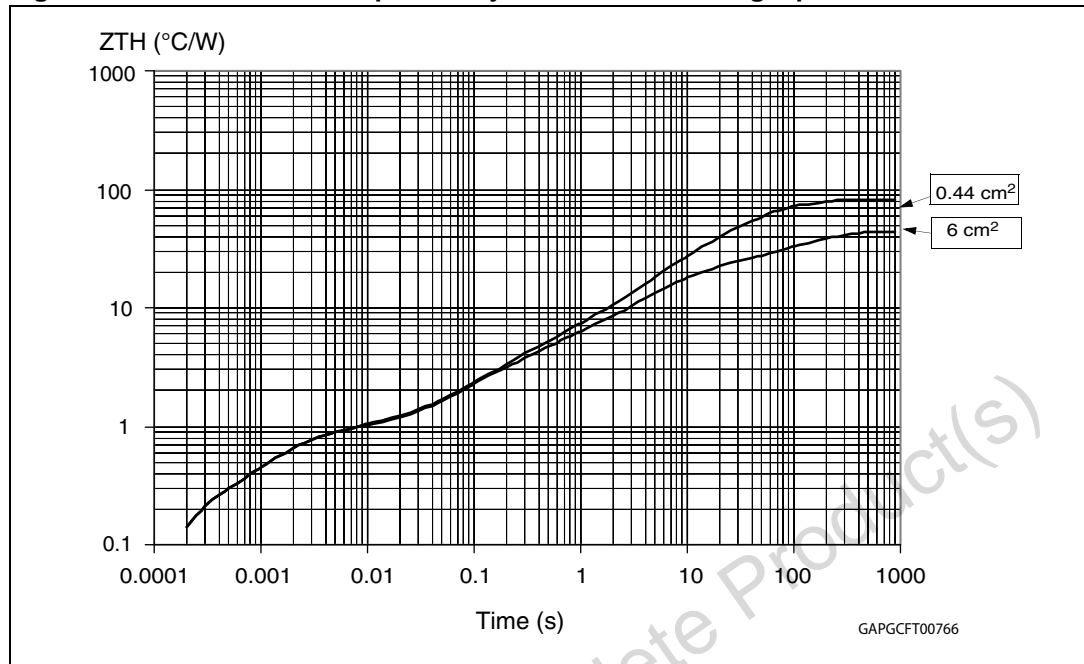

Figure 38. PPAK thermal impedance junction ambient single pulse



Equation 3: pulse calculation formula

$$Z_{TH\delta} = R_{TH} \cdot \delta + Z_{THtp}(1 - \delta)$$

where  $\delta = t_p/T$

Figure 39. Thermal fitting model of a single channel

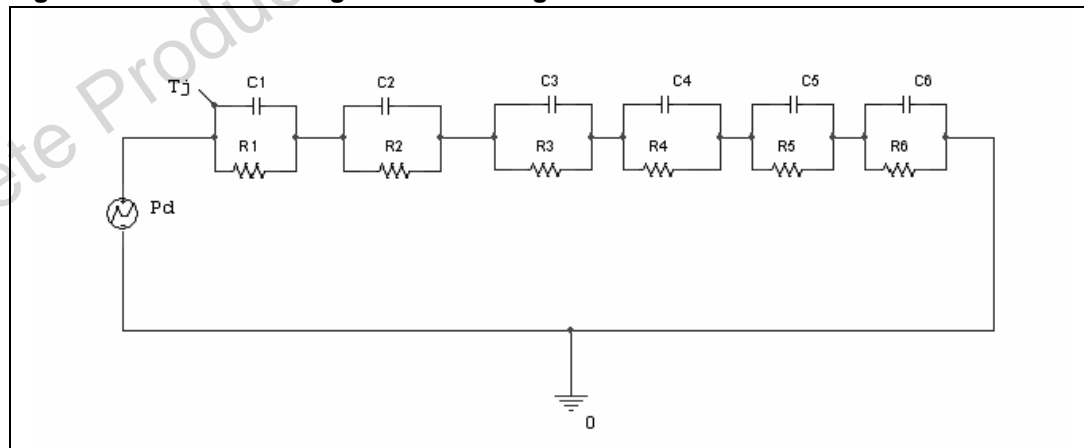

Table 18. Thermal parameter

Area/island (cm <sup>2</sup> )	0.5	6
R1 (°C/W)	0.15	
R2 (°C/W)	0.7	
R3 (°C/W)	1.6	
R4 (°C/W)	2	
R5 (°C/W)	15	
R6 (°C/W)	61	24
C1 (W·s/°C)	0.0006	
C2 (W·s/°C)	0.0025	
C3 (W·s/°C)	0.08	
C4 (W·s/°C)	0.3	
C5 (W·s/°C)	0.45	
C6 (W·s/°C)	0.8	5

## 4 Package and packing information

### 4.1 ECOPACK<sup>®</sup> packages

In order to meet environmental requirements, ST offers these devices in different grades of ECOPACK<sup>®</sup> packages, depending on their level of environmental compliance. ECOPACK<sup>®</sup> specifications, grade definitions and product status are available at: [www.st.com](http://www.st.com). ECOPACK<sup>®</sup> is an ST trademark.

### 4.2 SO-8 package information

Figure 40. SO-8 package dimensions

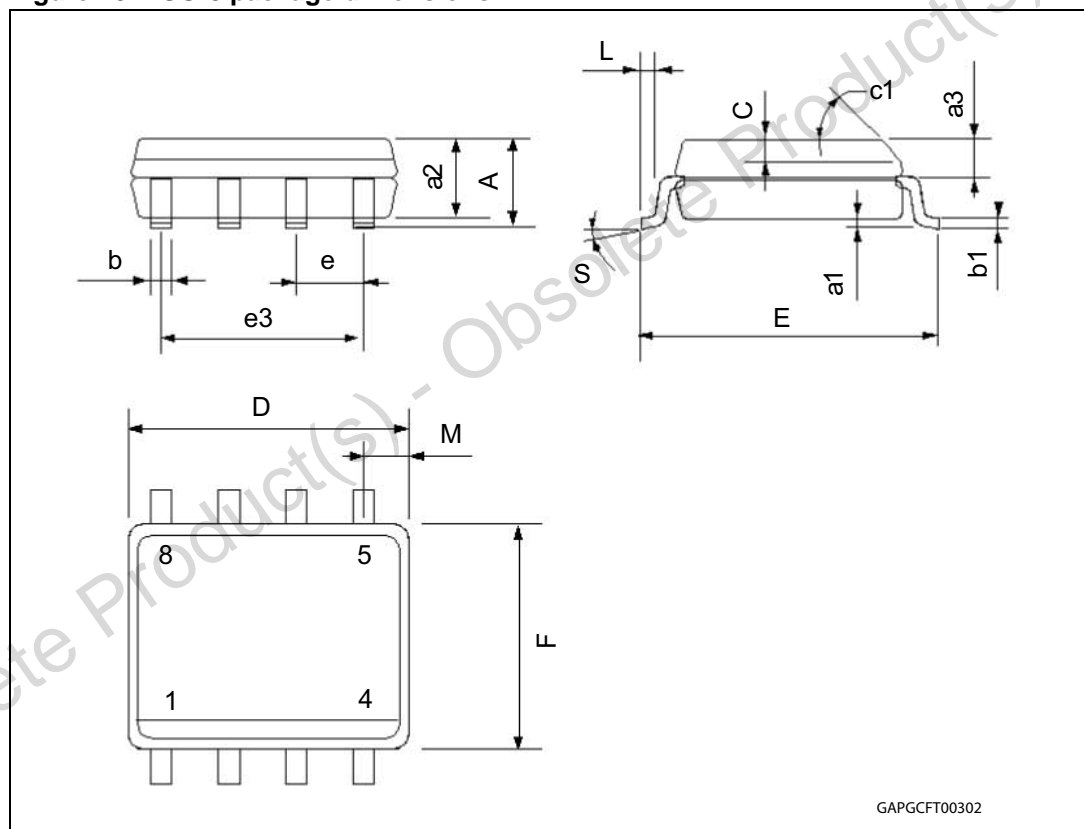

Table 19. SO-8 mechanical data

Dim.	mm		
	Min.	Typ.	Max.
A			1.75
a1	0.1		0.25
a2			1.65
a3	0.65		0.85
b	0.35		0.48
b1	0.19		0.25
C	0.25		0.5
c1	45 (typ.)		
D	4.8		5
E	5.8		6.2
e		1.27	
e3		3.81	
F	3.8		4
L	0.4		1.27
M			0.6
S	8 (max.)		
L1	0.8		1.2

### 4.3 PENTAWATT mechanical data

Figure 41. PENTAWATT package dimensions

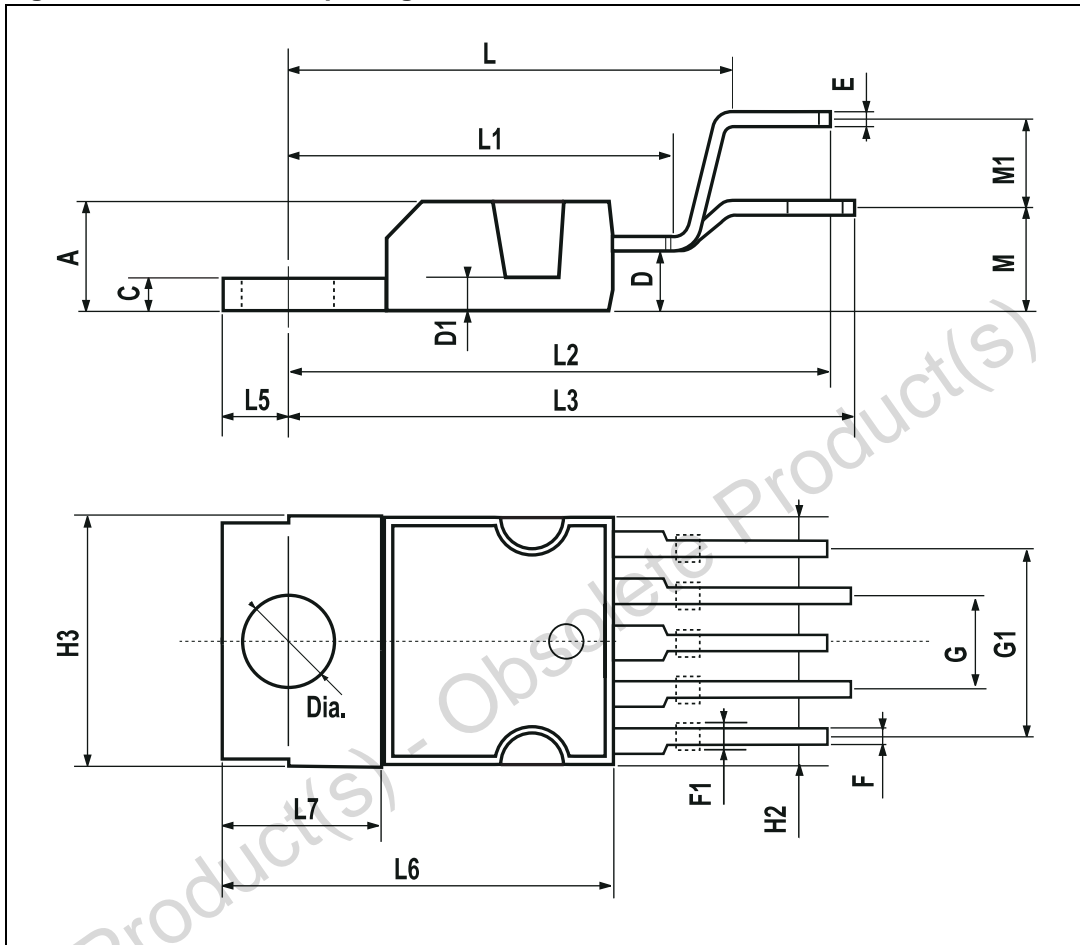

Table 20. PENTAWATT mechanical data

Dim.	mm		
	Min.	Typ.	Max.
A			4.8
C			1.37
D	2.4		2.8
D1	1.2		1.35
E	0.35		0.55
F	0.8		1.05
F1	1		1.4
G	3.2	3.4	3.6

Table 20. PENTAWATT mechanical data (continued)

Dim.	mm		
	Min.	Typ.	Max.
G1	6.6	6.8	7
H2			10.4
H3	10.05		10.4
L		17.85	
L1		15.75	
L2		21.4	
L3		22.5	
L5	2.6		3
L6	15.1		15.8
L7	6		6.6
M		4.5	
M1		4	
Diam.	3.65		3.85

### 4.4 P<sup>2</sup>PAK mechanical data

Figure 42. P<sup>2</sup>PAK package dimensions

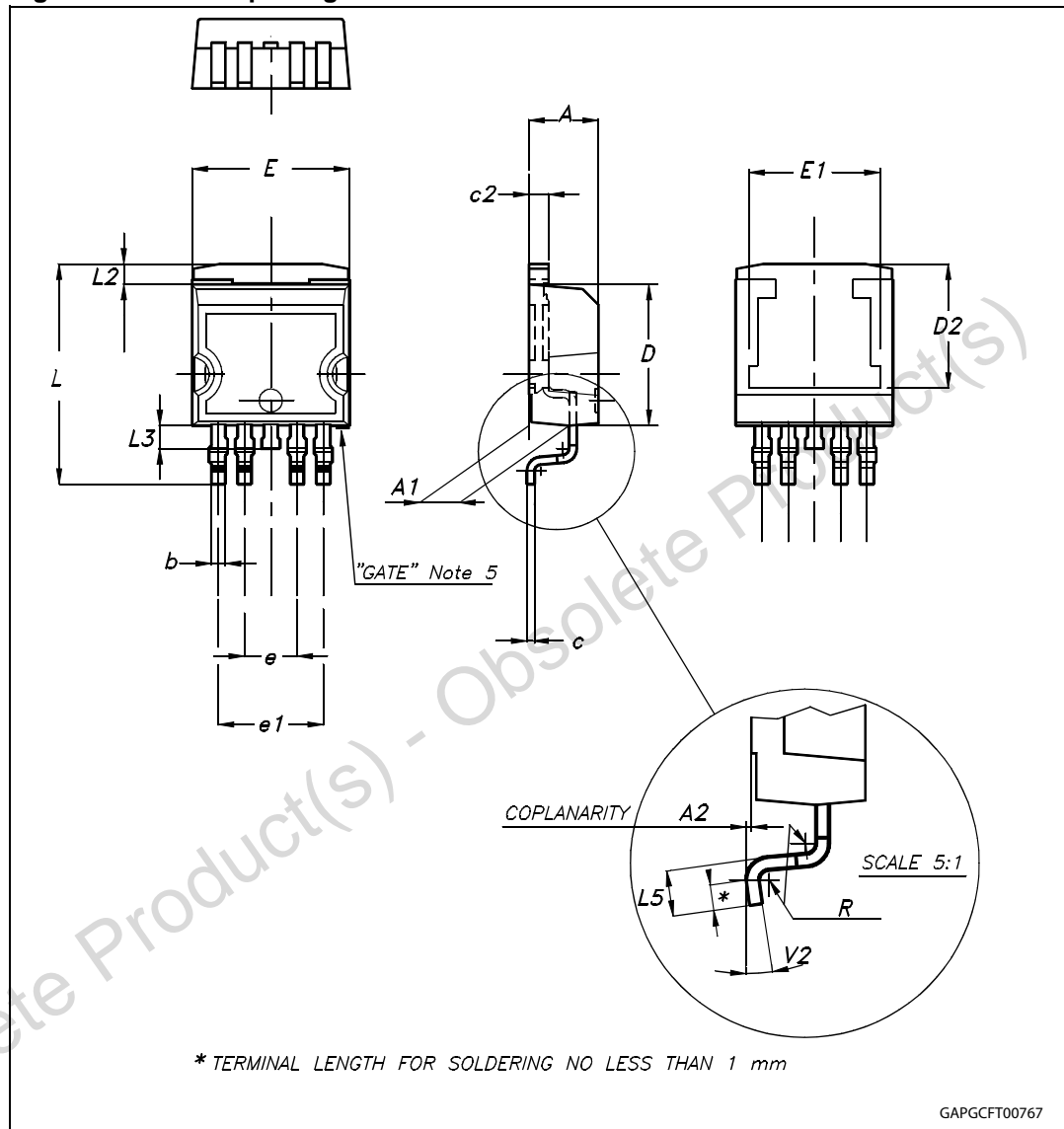

Table 21. P<sup>2</sup>PAK mechanical data

Dim.	mm		
	Min.	Typ.	Max.
A	4.30		4.80
A1	2.40		2.80
A2	0.03		0.23
b	0.80		1.05
c	0.45		0.60
c2	1.17		1.37
D	8.95		9.35
D2		8.00	
E	10.00		10.40
E1		8.50	
e	3.20		3.60
e1	6.60		7.00
L	13.70		14.50
L2	1.25		1.40
L3	0.90		1.70
L5	1.55		2.40
R		0.40	
V2	0°		8°
Package weight	1.40 Gr (typ)		

### 4.5 PPAK mechanical data

Figure 43. PPAK package dimensions

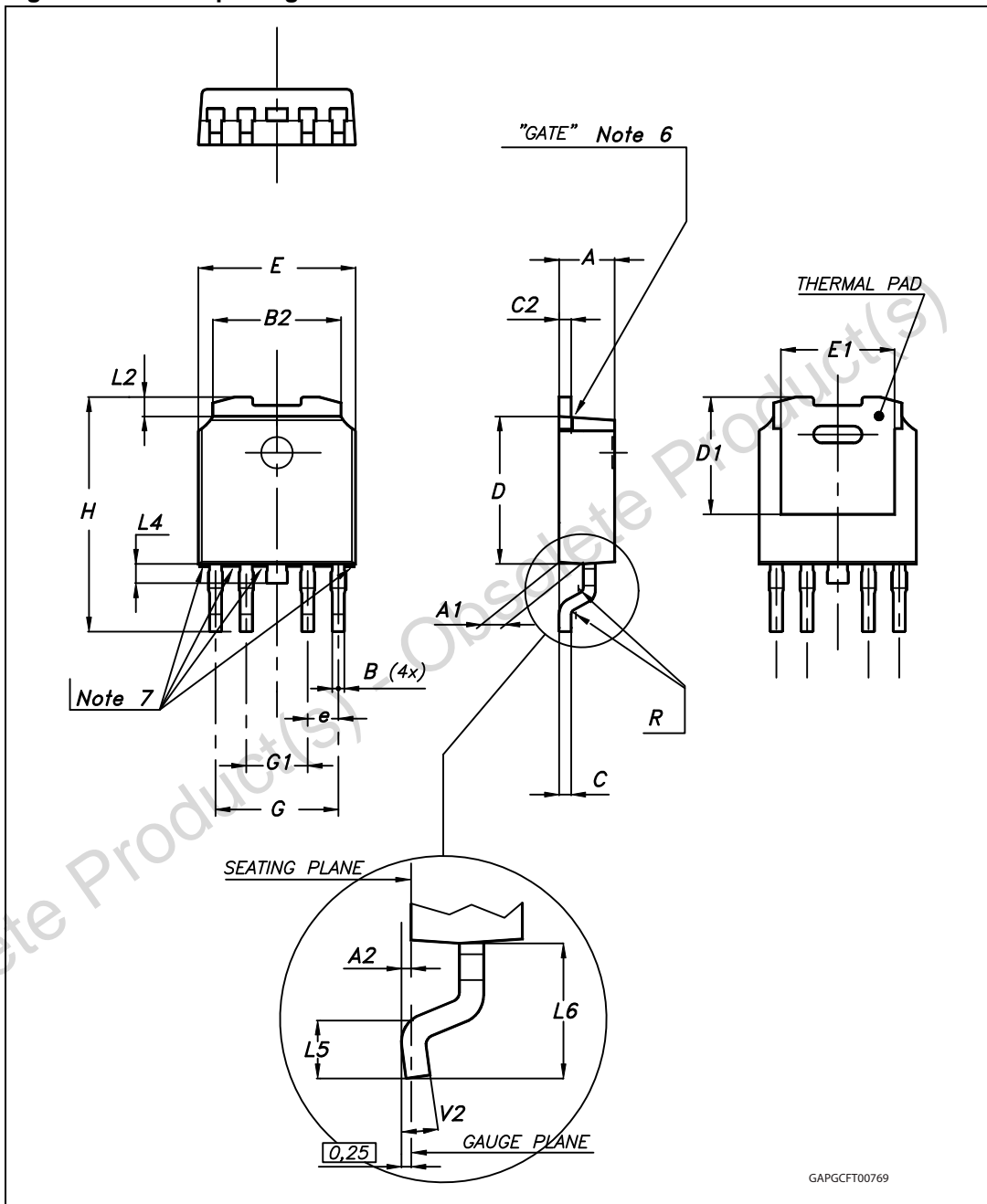

Table 22. PPAK mechanical data

Dim.	mm		
	Min.	Typ.	Max.
A	2.20		2.40
A1	0.90		1.10
A2	0.03		0.23
B	0.40		0.60
B2	5.20		5.40
C	0.45		0.60
C2	0.48		0.60
D	6.00		6.20
D1		5.1	
E	6.40		6.60
E1		4.7	
e		1.27	
G	4.90		5.25
G1	2.38		2.70
H	9.35		10.10
L2		0.8	1.00
L4	0.60		1.00
L5	1		—
L6		2.80	
R		0.2	
V2	0°		8°
Package weight	Gr. 0.3		

### 4.6 SO-8 packing information

The devices can be packed in tube or tape and reel shipments (see the [Table 1: Device summary](#)).

**Figure 44. SO-8 tube shipment (no suffix)**

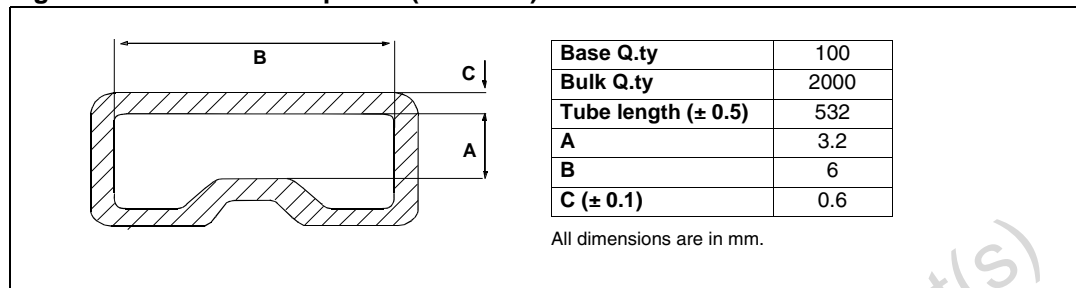

**Figure 45. SO-8 tape and reel shipment (suffix "TR")**

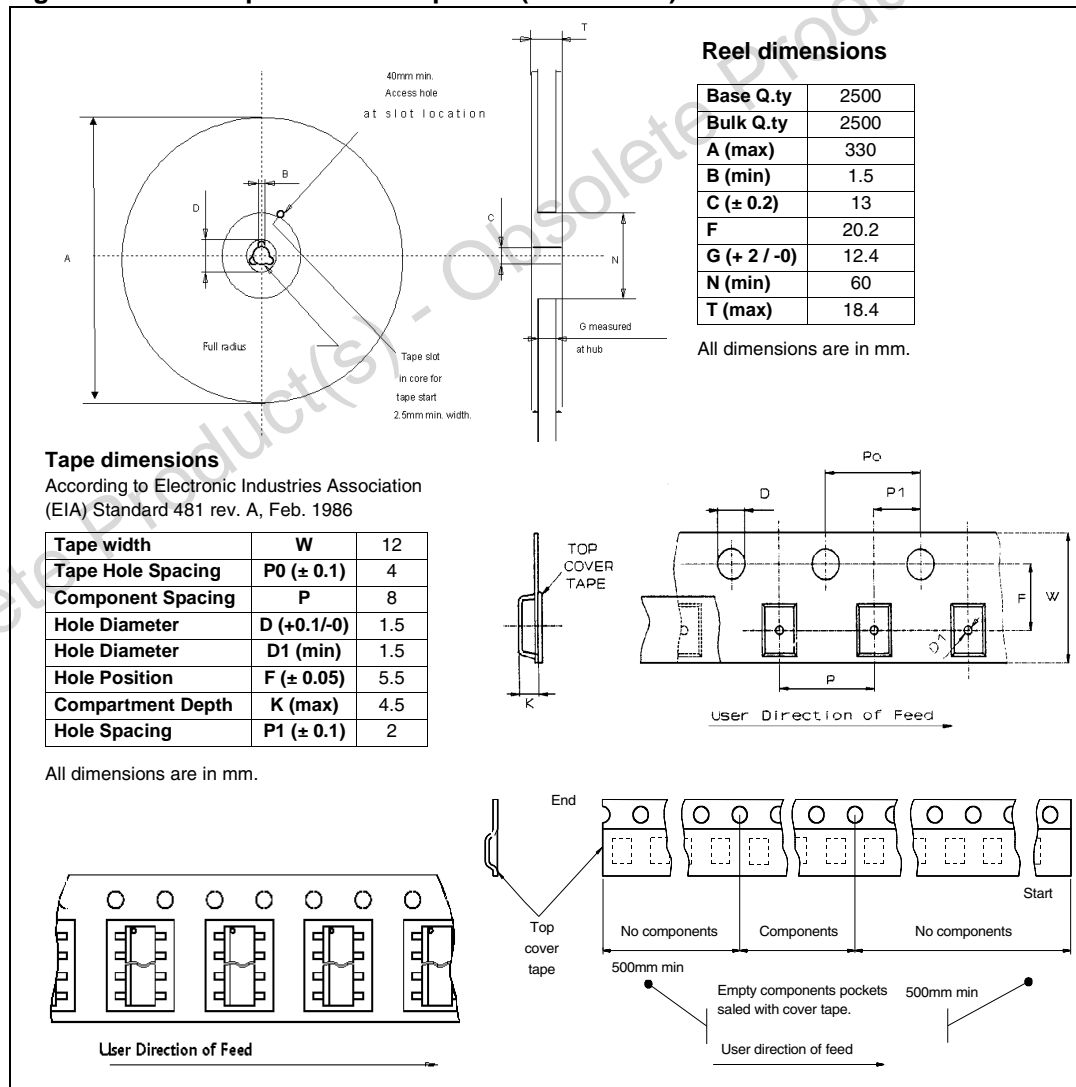

### 4.7 PENTAWATT packing information

The devices can be packed in tube or tape and reel shipments (see the [Table 1: Device summary](#)).

**Figure 46. PENTAWATT tube shipment (no suffix)**

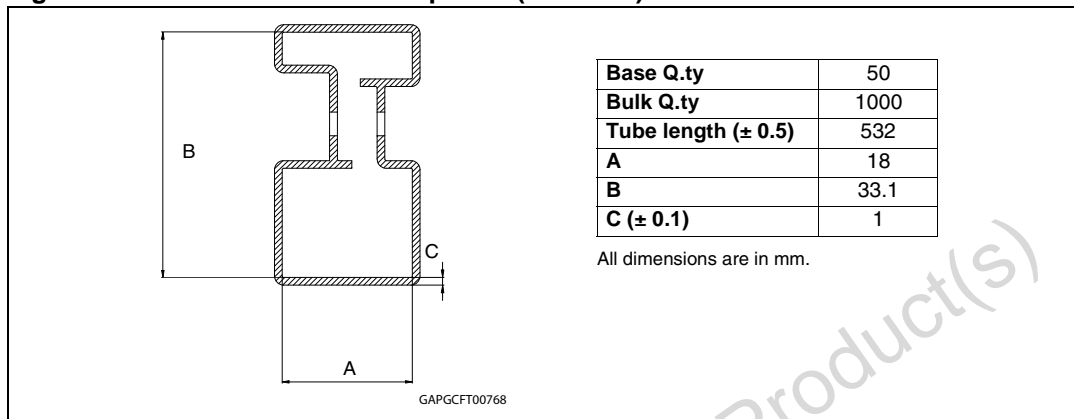

### 4.8 P<sup>2</sup>PAK packing information

The devices can be packed in tube or tape and reel shipments (see the [Table 1: Device summary](#)).

**Figure 47. P<sup>2</sup>PAK tube shipment (no suffix)**

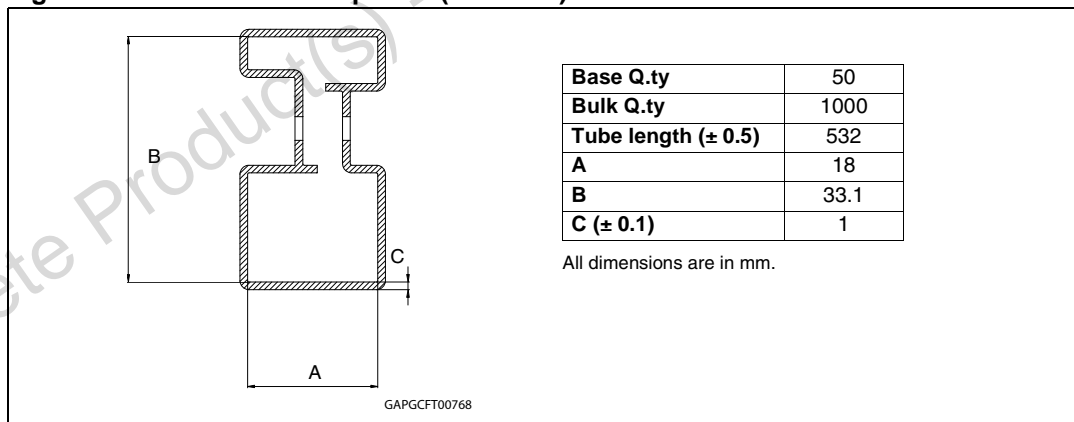
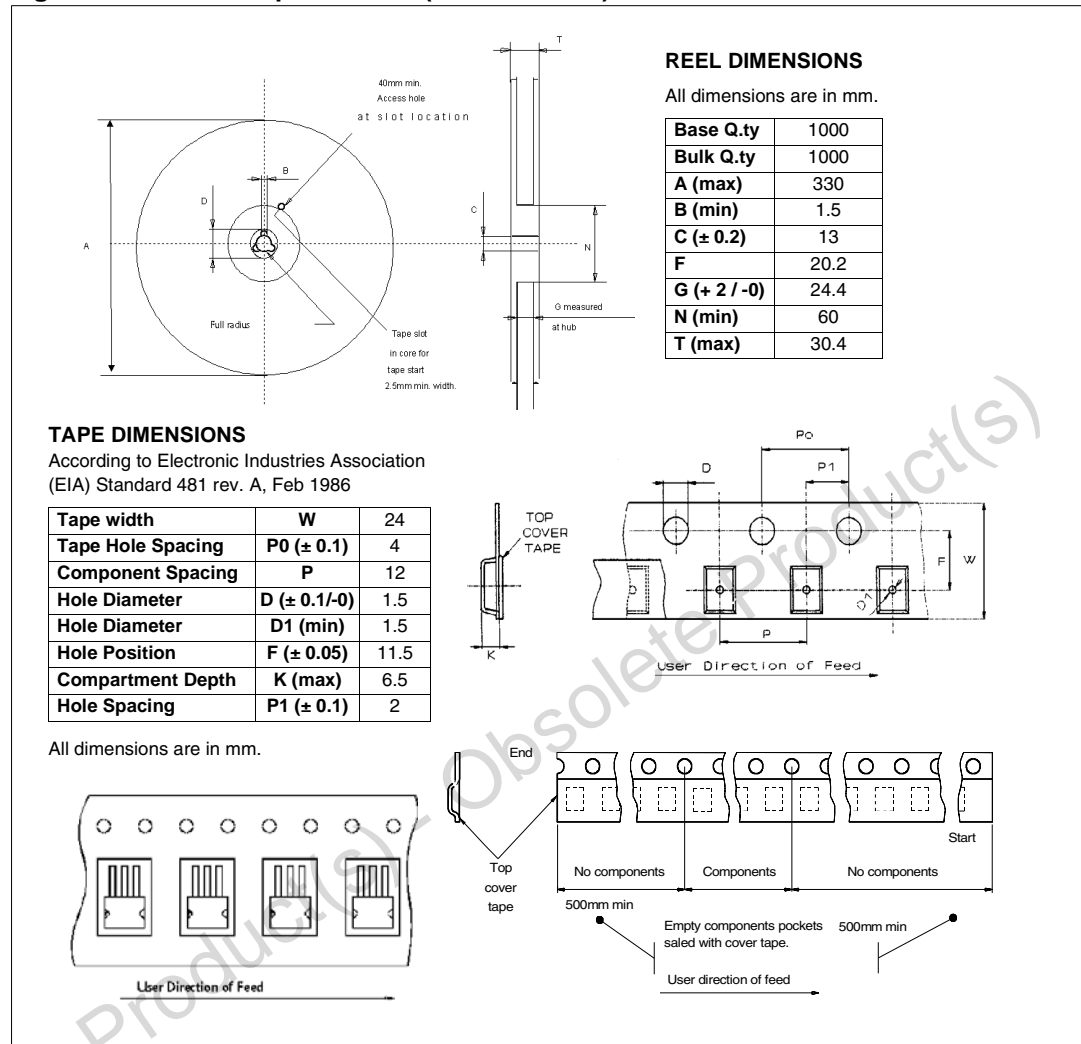

Figure 48. P<sup>2</sup>PAK tape and reel (suffix "13TR")



### 4.9 PPAK packing information

The devices can be packed in tube or tape and reel shipments (see the [Table 1: Device summary](#)).

**Figure 49. PPAK suggested pad layout**

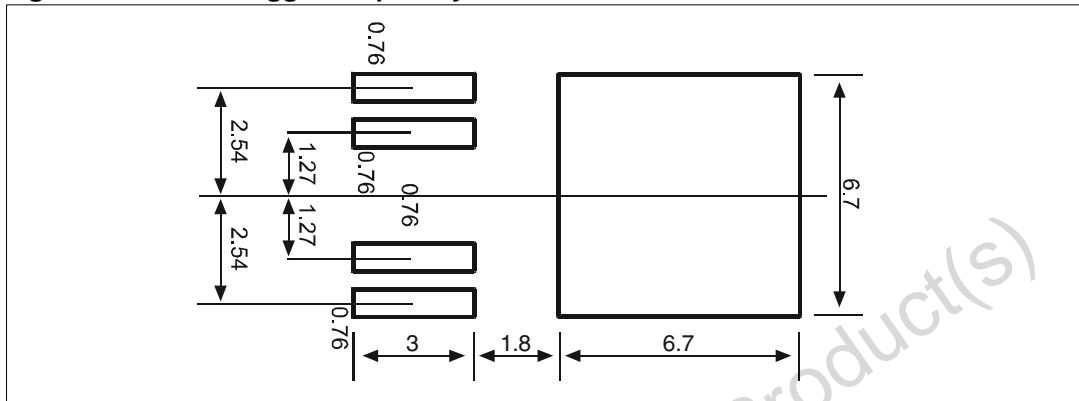

**Figure 50. PPAK tube shipment (no suffix)**

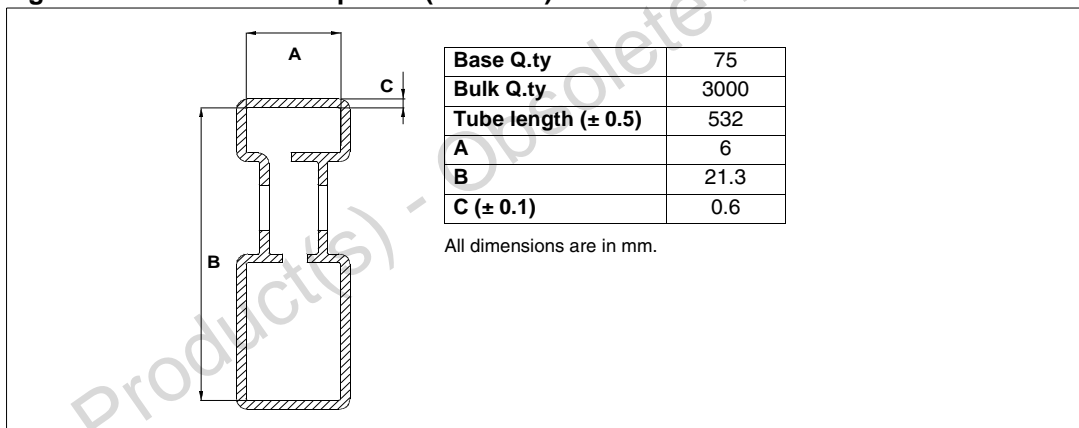
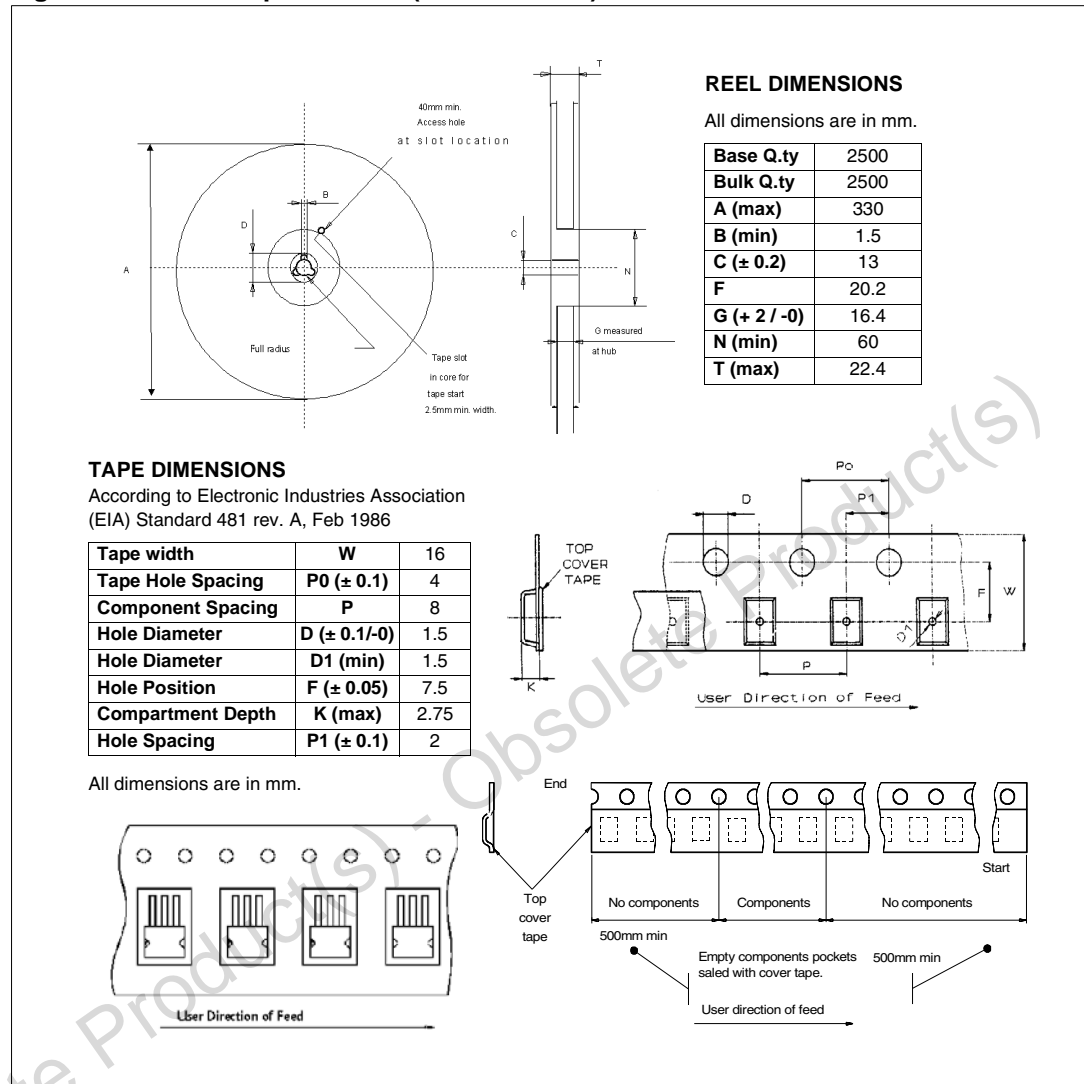

Figure 51. PPAK tape and reel (suffix "13TR")



## 5 Revision history

**Table 23. Document revision history**

Date	Revision	Changes
21-Jun-2004	1	Initial release.
03-May-2006	2	Current and voltage convention update (page 2). Configuration diagram (top view) & suggested connections for unused and n.c. pins: insertion (page 2). 6cm <sup>2</sup> Cu condition insertion in thermal data table (page 3). V <sub>CC</sub> - output diode section update (page 4). Revision history table insertion (page 30). Disclaimers update (page 31).
24-Nov-2008	3	Document reformatted and restructured. Added content, list of figures and tables. Added <i>ECOPACK<sup>®</sup> packages</i> information. Updated <i>Figure 48.: P<sup>2</sup>PAK tape and reel (suffix "13TR")</i> : – changed component spacing (P) in tape dimensions table from 16 mm to 12 mm.
18-May-2012	4	Updated <i>Section 4.5: PPAK mechanical data</i>

**Please Read Carefully:**

Information in this document is provided solely in connection with ST products. STMicroelectronics NV and its subsidiaries ("ST") reserve the right to make changes, corrections, modifications or improvements, to this document, and the products and services described herein at any time, without notice.

All ST products are sold pursuant to ST's terms and conditions of sale.

Purchasers are solely responsible for the choice, selection and use of the ST products and services described herein, and ST assumes no liability whatsoever relating to the choice, selection or use of the ST products and services described herein.

No license, express or implied, by estoppel or otherwise, to any intellectual property rights is granted under this document. If any part of this document refers to any third party products or services it shall not be deemed a license grant by ST for the use of such third party products or services, or any intellectual property contained therein or considered as a warranty covering the use in any manner whatsoever of such third party products or services or any intellectual property contained therein.

**UNLESS OTHERWISE SET FORTH IN ST'S TERMS AND CONDITIONS OF SALE ST DISCLAIMS ANY EXPRESS OR IMPLIED WARRANTY WITH RESPECT TO THE USE AND/OR SALE OF ST PRODUCTS INCLUDING WITHOUT LIMITATION IMPLIED WARRANTIES OF MERCHANTABILITY, FITNESS FOR A PARTICULAR PURPOSE (AND THEIR EQUIVALENTS UNDER THE LAWS OF ANY JURISDICTION), OR INFRINGEMENT OF ANY PATENT, COPYRIGHT OR OTHER INTELLECTUAL PROPERTY RIGHT.**

**UNLESS EXPRESSLY APPROVED IN WRITING BY TWO AUTHORIZED ST REPRESENTATIVES, ST PRODUCTS ARE NOT RECOMMENDED, AUTHORIZED OR WARRANTED FOR USE IN MILITARY, AIR CRAFT, SPACE, LIFE SAVING, OR LIFE SUSTAINING APPLICATIONS, NOR IN PRODUCTS OR SYSTEMS WHERE FAILURE OR MALFUNCTION MAY RESULT IN PERSONAL INJURY, DEATH, OR SEVERE PROPERTY OR ENVIRONMENTAL DAMAGE. ST PRODUCTS WHICH ARE NOT SPECIFIED AS "AUTOMOTIVE GRADE" MAY ONLY BE USED IN AUTOMOTIVE APPLICATIONS AT USER'S OWN RISK.**

Resale of ST products with provisions different from the statements and/or technical features set forth in this document shall immediately void any warranty granted by ST for the ST product or service described herein and shall not create or extend in any manner whatsoever, any liability of ST.

ST and the ST logo are trademarks or registered trademarks of ST in various countries.

Information in this document supersedes and replaces all information previously supplied.

The ST logo is a registered trademark of STMicroelectronics. All other names are the property of their respective owners.

© 2012 STMicroelectronics - All rights reserved



STMicroelectronics group of companies

Australia - Belgium - Brazil - Canada - China - Czech Republic - Finland - France - Germany - Hong Kong - India - Israel - Italy - Japan - Malaysia - Malta - Morocco - Philippines - Singapore - Spain - Sweden - Switzerland - United Kingdom - United States of America

[www.st.com](http://www.st.com)

## Looking for pricing, stock, or lifecycle information?

Click below to explore more details on WIN SOURCE:

-  [View VN750-B5 on WIN SOURCE](#)
-  [STMicroelectronics](#) Information

## Optimize Your Supply Chain with WIN SOURCE Solutions

-  Global Sourcing Solution
-  Obsolete Management
-  Cost Control Management
-  Shortage Management
-  Alternative Solution
-  Excess Inventory Management