



THE DATASHEET OF AS1701



AS1701, AS1706

1.6W Audio Power Amplifiers

1 General Description

The AS1701 and AS1706 are 1.6W bridged audio power amplifiers that provide excellent circuit reliability, providing a very low-cost solution by eliminating external components when used with 2.7 to 5.5V-powered circuits.

The devices have superb total harmonic distortion (THD) at high-power output and excellent power supply rejection with 4- and 8Ω-loads.

Integrated over-temperature and over-current protection circuitry switch the devices off in case of an output short-circuit. A digital input allows the devices to automatically switch into shutdown mode. Click- and pop-suppression circuitry reduces audible clicks and pops during power-up and shutdown. The gain (A_v) of the devices is controlled using external resistors.

The AS1701/AS1706 are available in an 8-pin MSOP package.

2 Key Features

- 2.7 to 5.5V (V_{DD}) Single-Supply Operation
- Very High PSRR: Greater Than 65dB @ 217Hz
- THD+Noise: 1.6W into 4Ω at 1%
- No Output Coupling Capacitors Required
- External Gain Configuration Capability
- Low-Power Shutdown Mode: 10nA
- Click and Pop Suppression
- Over-Temperature and Over-Current Protection
- Operating Temperature Range: -40 to +85°C
- 8-pin MSOP Package

3 Applications

The AS1701/AS1706 are ideal as audio front-ends for battery powered audio devices such as MP3 and CD players, mobile phones, PDAs, portable DVD players, and any other hand-held battery-powered device.

Figure 1. Typical Configuration Block Diagram

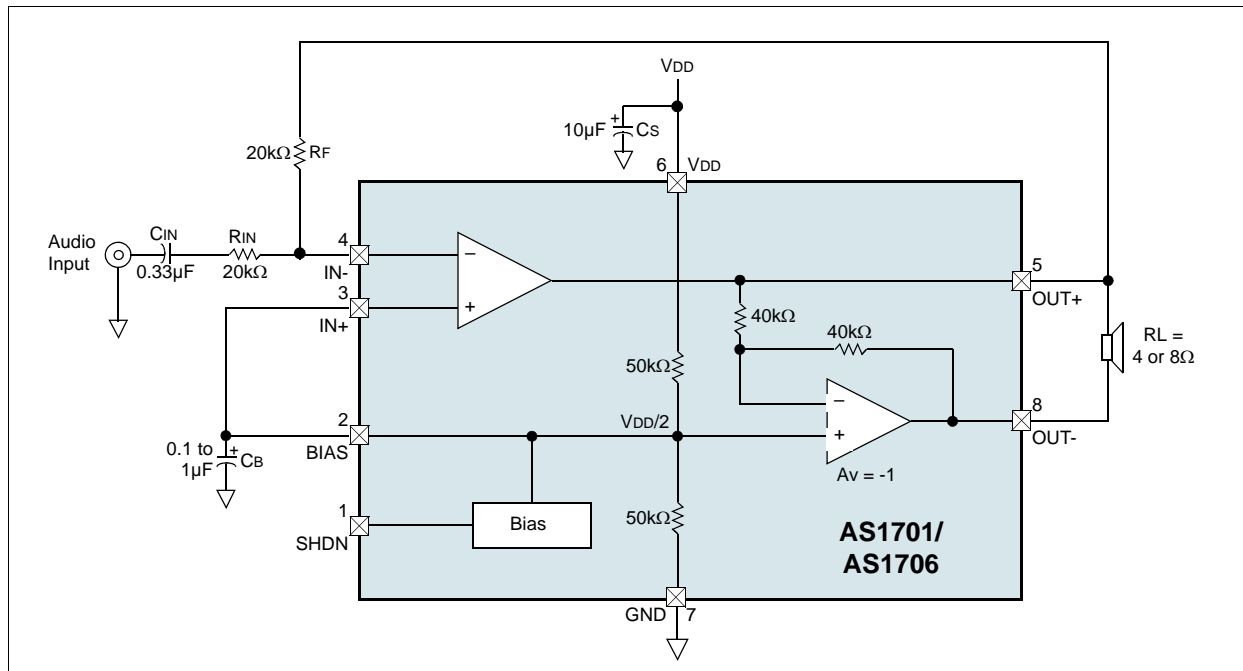

4 Pinout

Pin Assignments

Figure 2. Pin Assignment - 8-pin MSOP (Top View)

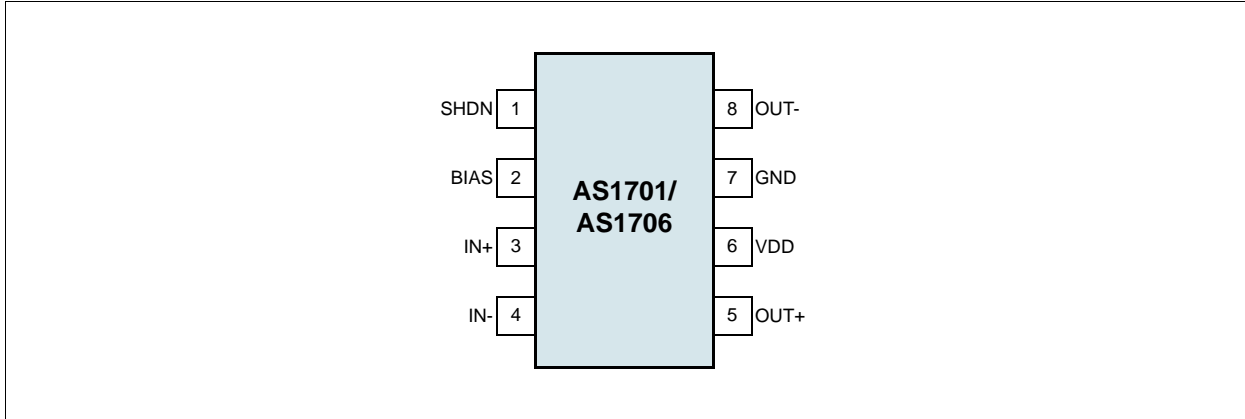

Pin Descriptions

Table 1. Pin Descriptions

Pin Number	Pin Name	Description
1	SHDN	Shutdown. Connect this pin to GND for the AS1701 (active-high); connect this pin to VDD for the AS1706 (active-low).
2	BIAS	DC Bias Bypass
3	IN+	Non-Inverting Input
4	IN-	Inverting Input
5	OUT+	Positive Differential Output
6	VDD	Power Supply
7	GND	Ground
8	OUT-	Negative Differential Output

5 Absolute Maximum Ratings

Stresses beyond those listed in [Table 2](#) may cause permanent damage to the device. These are stress ratings only, and functional operation of the device at these or any other conditions beyond those indicated in [Electrical Characteristics on page 4](#) is not implied. Exposure to absolute maximum rating conditions for extended periods may affect device reliability.

Table 2. Absolute Maximum Ratings

Parameter	Min	Max	Units	Comments
Electrical Parameters				
Supply Voltage (VDD to VSS)	-0.3	+7	V	
Supply Voltage (All Other Pins)	VSS - 0.3	VDD + 0.3	V	
Input Current (latch-up immunity)	-100	100	mA	Norm: JEDEC 78
Electrostatic Discharge				
Electrostatic Discharge HBM		1	kV	Norm: MIL 883 E method 3015
Temperature Ranges and Storage Conditions				
Continuous Power Dissipation		362	mW	T _{AMB} = 70°C, Derate 4.5mW/°C Above +70°C
Storage Temperature Range	-65	+150	°C	
Junction Temperature		+150	°C	
Package Body Temperature		+260	°C	The reflow peak soldering temperature (body temperature) specified is in accordance with <i>IPC/JEDEC J-STD-020 "Moisture/Reflow Sensitivity Classification for Non-Hermetic Solid State Surface Mount Devices"</i> . The lead finish for Pb-free leaded packages is matte tin (100% Sn).
Humidity non-condensing	5	85	%	
Moisture Sensitive Level		1		Represents a max. floor life time of unlimited

6 Electrical Characteristics

All limits are guaranteed. The parameters with min and max values are guaranteed with production tests or SQC (Statistical Quality Control) methods.

5V Operation

$V_{DD} = 5V$, $R_L = \infty$, $C_{BIAS} = 0.1\mu F$ to GND, $SHDN = GND$, $T_{AMB} + 25^\circ C$ (unless otherwise specified).

Table 3. DC Electrical Characteristics – 5V Operation

Parameter	Symbol	Conditions	Min	Typ	Max	Units
Operating Temperature Range	T_{AMB}		-45		+85	$^\circ C$
Supply Voltage Range	V_{DD}	Inferred from PSRR Test	2.7		5.5	V
Supply Current ¹	I_{DD}	$T_{AMB} = -40$ to $+85^\circ C$		6.8	10.4	mA
Shutdown Supply Current	I_{SHDN}	$SHDN = V_{DD}$		0.01	1	μA
SHDN Threshold		V_{IH}	$V_{DD} \times 0.7$			V
		V_{IL}			$V_{DD} \times 0.3$	
Common-Mode Bias Voltage ²	V_{BIAS}		$V_{DD}/2 - 5\%$	$V_{DD}/2$	$V_{DD}/2 + 5\%$	V
Output Offset Voltage	V_{OS}	$A_v = 2$, $I_{N-} = OUT+$, $I_{N-} = BIAS$		± 1	± 10	mV
Power Supply Rejection Ratio	PSRR	Inputs Grounded, $V_{RIPPLE} = 200mVp-p$, $R_L = 4\Omega$, $V_{IN-} = V_{IN+} = V_{BIAS}$	217Hz	65		dB
			1kHz	63		
Output Power ³	P_{OUT}	$R_L = 4\Omega$, $THD+N = 1\%$, $f_{IN} = 1kHz$		1.6		W
		$R_L = 8\Omega$, $THD+N = 1\%$, $f_{IN} = 1kHz$	0.8	1.2		
Total Harmonic Distortion+Noise	THD+N	$A_v = 2$, $R_L = 4\Omega$, $f_{IN} = 1kHz$, $P_{OUT} = 1.3W$		0.09		%
		$A_v = 2$, $R_L = 8\Omega$, $f_{IN} = 1kHz$, $P_{OUT} = 1W$		0.05		
Thermal-Shutdown Threshold				145		$^\circ C$
Thermal-Shutdown Hysteresis				9		$^\circ C$
Power-Up/Enable from Shutdown Time	t_{PU}			150		ms
Shutdown Time	t_{SHDN}			1		μs
Turn-Off Transient	V_{POP}			20		mV

1. Quiescent power supply current is specified and tested without loads on the outputs. Quiescent power supply current depends on the offset voltage when a practical load is connected to the device.
2. Common-mode bias voltage is the voltage on pin BIAS and is nominally $V_{DD}/2$.
3. Guaranteed by design.

3V Operation

$V_{DD} = 3V$, $R_L = \infty$, $C_{BIAS} = 0.1\mu F$ to GND, $SHDN = GND$, $T_{AMB} + 25^\circ C$ (unless otherwise specified).

Table 4. DC Electrical Characteristics – 3V Operation

Parameter	Symbol	Conditions	Min	Typ	Max	Units
Supply Current ¹	I_{DD}	$T_{AMB} = -40$ to $+85^\circ C$		6	10	mA
Shutdown Supply Current	I_{SHDN}	$SHDN = V_{DD}$		0.01	1	μA
Output Power ²	P_{OUT}	$R_L = 4\Omega$, $THD+N = 1\%$, $f_{IN} = 1kHz$		0.6		W
		$R_L = 8\Omega$, $THD+N = 1\%$, $f_{IN} = 1kHz$		0.4		
Power Supply Rejection Ratio	PSRR	$V_{RIPPLE} = 200mVp-p$, $R_L = 8\Omega$, $V_{IN-} = V_{IN+} = V_{BIAS}$	217Hz	65		dB
			1kHz	63		
Total Harmonic Distortion +Noise	THD+N	$A_v = 2$, $R_L = 4\Omega$, $f_{IN} = 1kHz$, $P_{OUT} = 500mW$		0.09		%
		$A_v = 2$, $R_L = 8\Omega$, $f_{IN} = 1kHz$, $P_{OUT} = 350mW$		0.06		

1. Quiescent power supply current is specified and tested without loads on the outputs. Quiescent power supply current depends on the offset voltage when a practical load is connected to the device.
2. Guaranteed by design.

7 Typical Operating Characteristics

Figure 3. THD + Noise vs. Output Power;
 $V_{DD} = 3V, R_L = 4\Omega, A_v = 2V_{DD} = 3V, R_L = 8\Omega, A_v = 2$

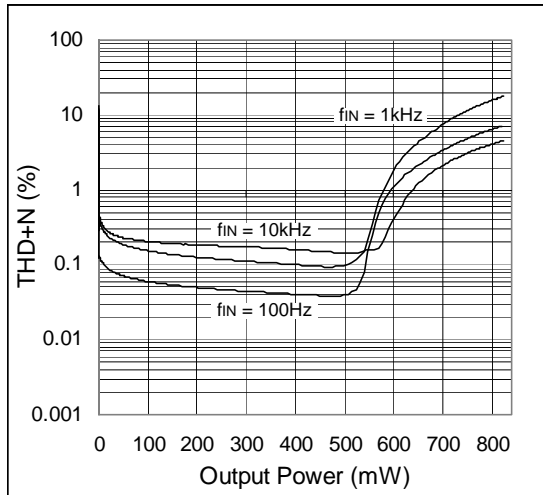

Figure 5. THD + Noise vs. Output Power;
 $V_{DD} = 3V, R_L = 4\Omega, A_v = 4V_{DD} = 3V, R_L = 8\Omega, A_v = 4$

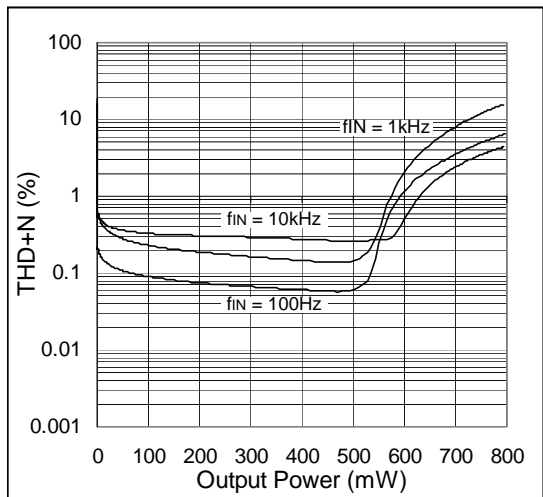

Figure 7. THD + Noise vs. Output Power;
 $V_{DD} = 5V, R_L = 4\Omega, A_v = 2V_{DD} = 5V, R_L = 8\Omega, A_v = 2$

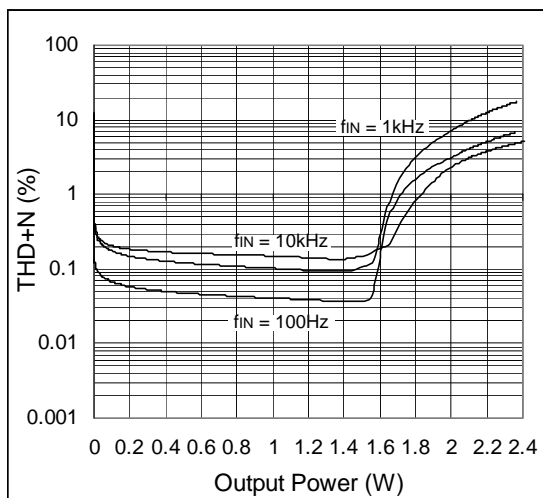

Figure 4. THD + Noise vs. Output Power;

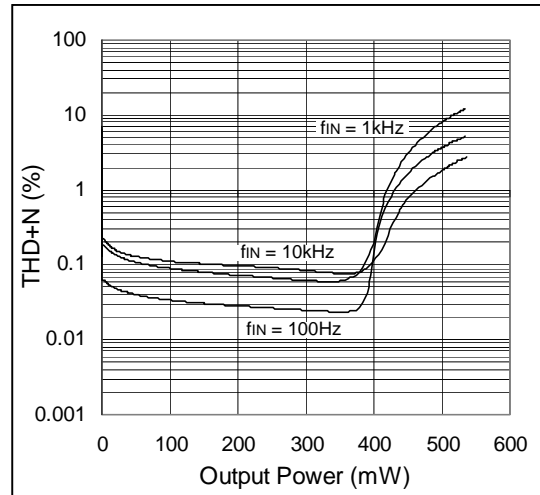

Figure 6. THD + Noise vs. Output Power;

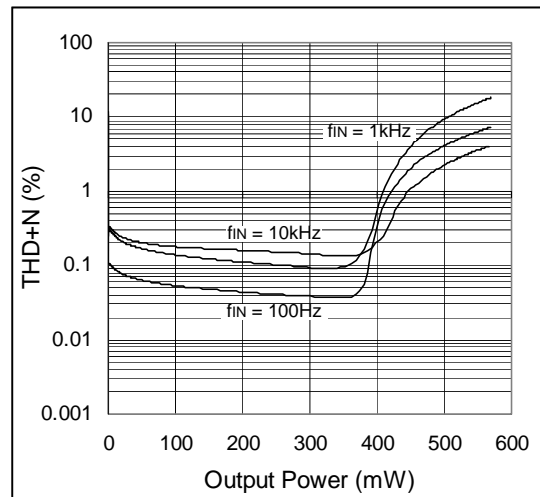

Figure 8. THD + Noise vs. Output Power;

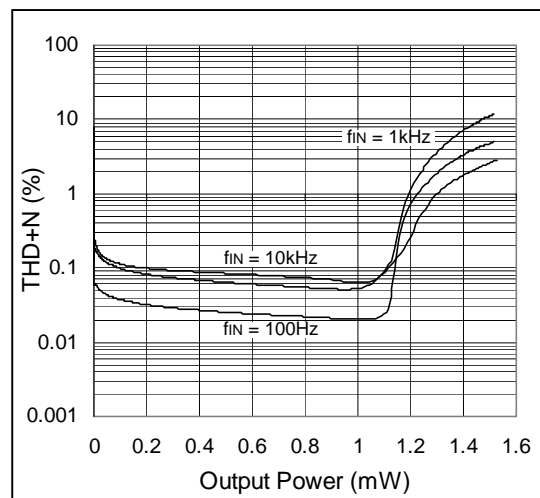

Figure 9. THD + Noise vs. Output Power;
 $V_{DD} = 5V, R_L = 4\Omega, A_v = 4V_{DD} = 5V, R_L = 8\Omega, A_v = 4$

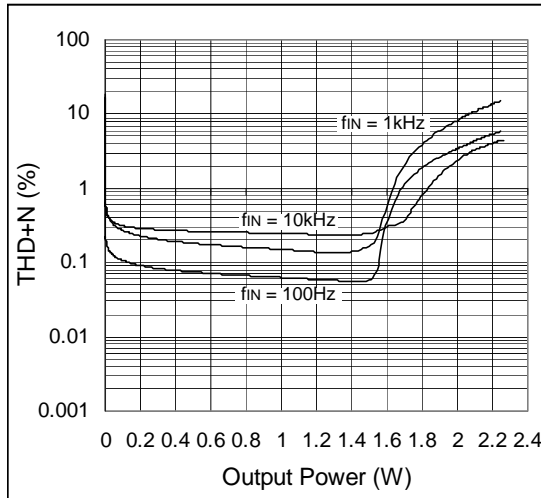

Figure 10. THD + Noise vs. Output Power;

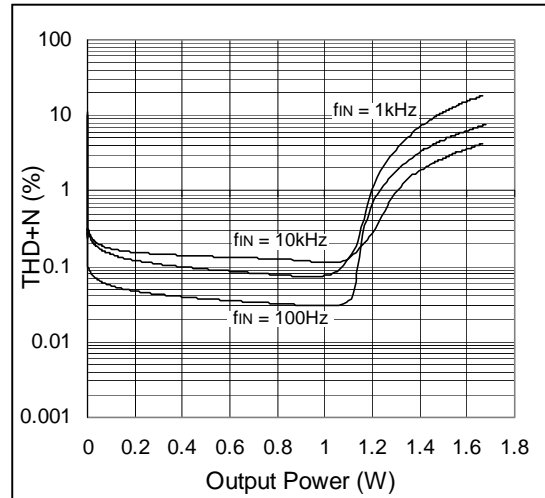

Figure 11. THD + Noise vs. Frequency;
 $V_{DD} = 3V, R_L = 4\Omega, A_v = 2V_{DD} = 3V, R_L = 8\Omega, A_v = 2$

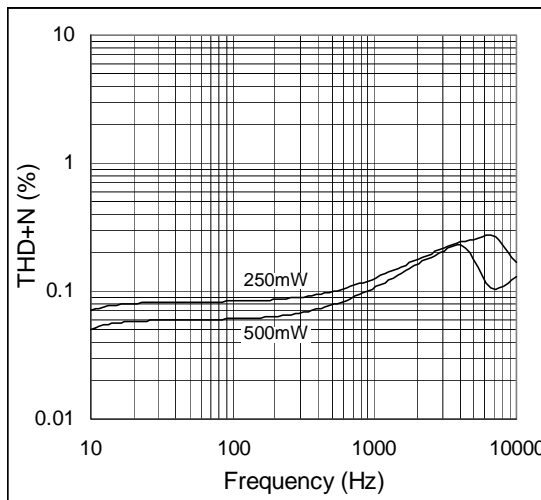

Figure 12. THD + Noise vs. Frequency;

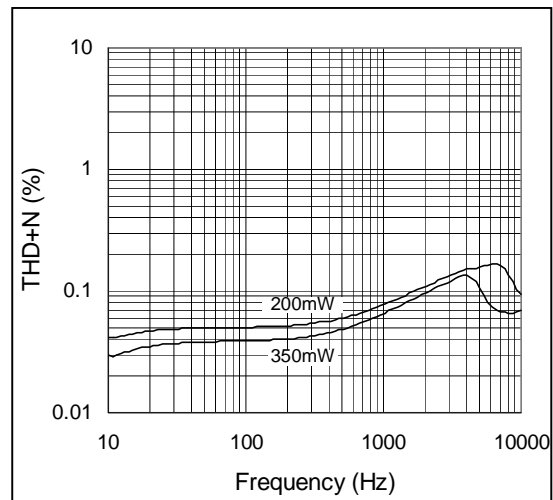

Figure 13. THD + Noise vs. Frequency;
 $V_{DD} = 5V, R_L = 4\Omega, A_v = 2V_{DD} = 5V, R_L = 8\Omega, A_v = 2$

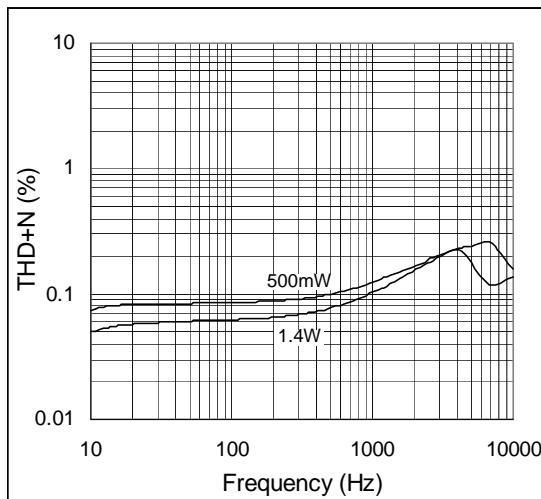

Figure 14. THD + Noise vs. Frequency;

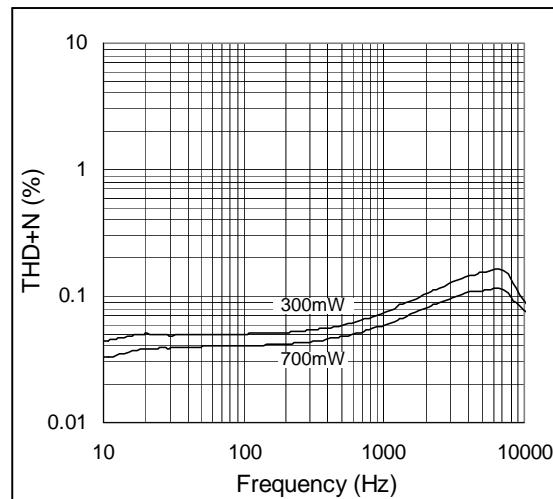

Figure 15. THD + Noise vs. Frequency; $V_{DD} = 5V, R_L = 4\Omega, A_v = 4V_{DD} = 5V, R_L = 8\Omega, A_v = 4$

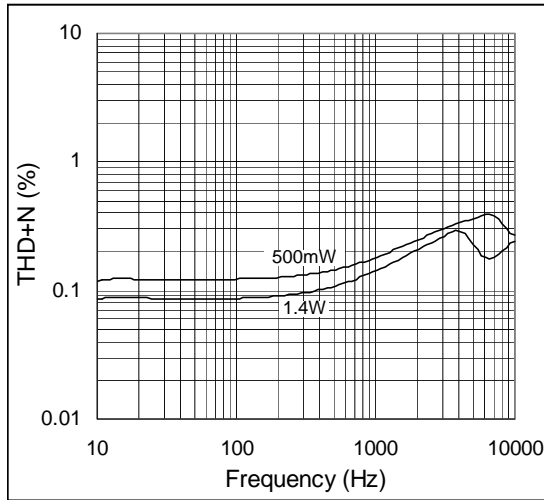

Figure 16. THD + Noise vs. Frequency;

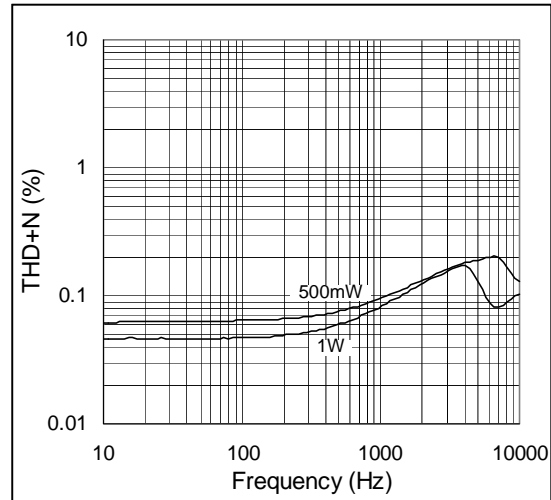

Figure 17. Power Dissipation vs. P_{OUT} ; $V_{DD} = 5V, A_v = 2, R_L = 4\Omega, f = 1kHz, THD+N < 1\%$

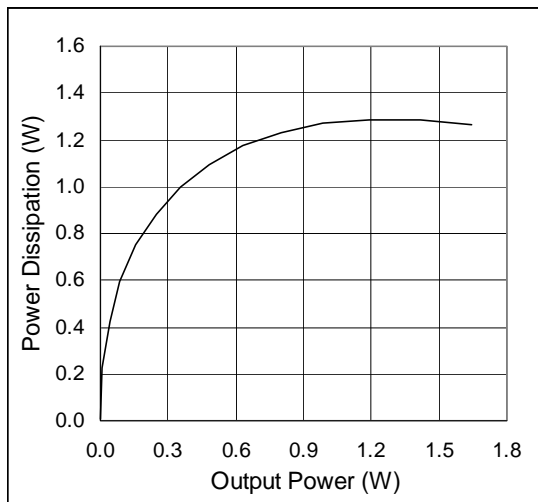

Figure 18. Power Dissipation vs. P_{OUT} ; $V_{DD} = 3V, A_v = 2, R_L = 8\Omega, f = 1kHz, THD+N < 1\%$

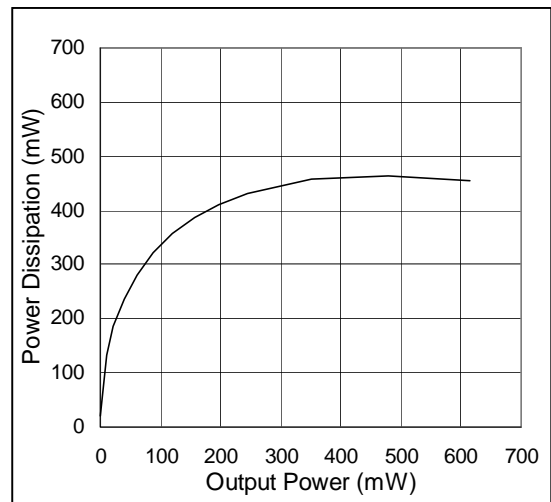

Figure 19. Power Dissipation vs. P_{OUT} ; $V_{DD} = 5V, A_v = 2, R_L = 8\Omega, f = 1kHz, THD+N < 1\%$

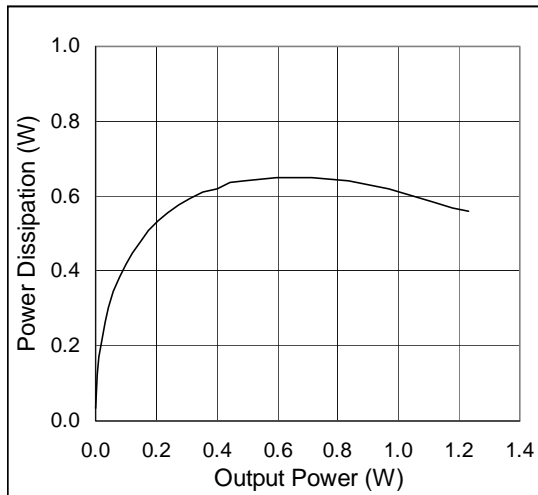

Figure 20. Power Dissipation vs. P_{OUT} ; $V_{DD} = 3V, A_v = 2, R_L = 4\Omega, f = 1kHz, THD+N < 1\%$

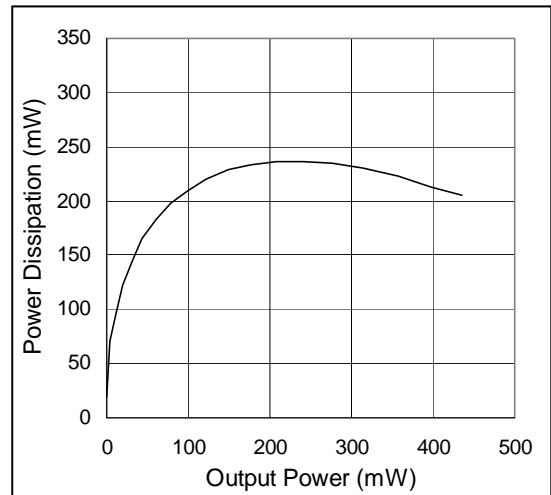

Figure 21. Output Power vs. Supply Voltage; $f = 1\text{kHz}$, $R_L = 4\Omega$, $A_v = 2$

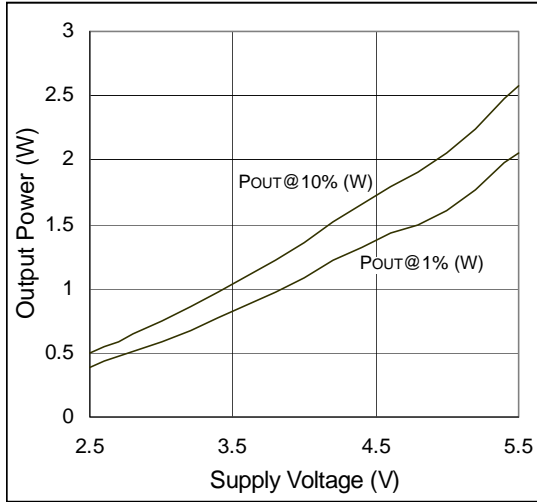

Figure 22. Output Power vs. Supply Voltage; $f = 1\text{kHz}$, $R_L = 8\Omega$, $A_v = 2$

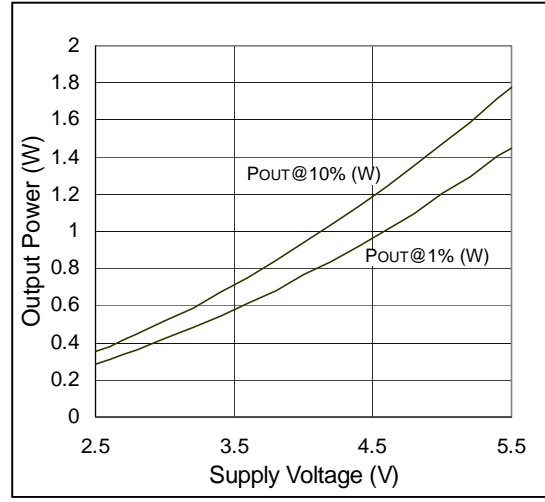

Figure 23. PSRR vs. Frequency; $V_{RIPPLE} = 200\text{mVPP}$, $C_{BP} = C_{IN} = 1\mu\text{F}$, $R_L = 4\Omega$, $A_v = 2$, $In1$ Grounded

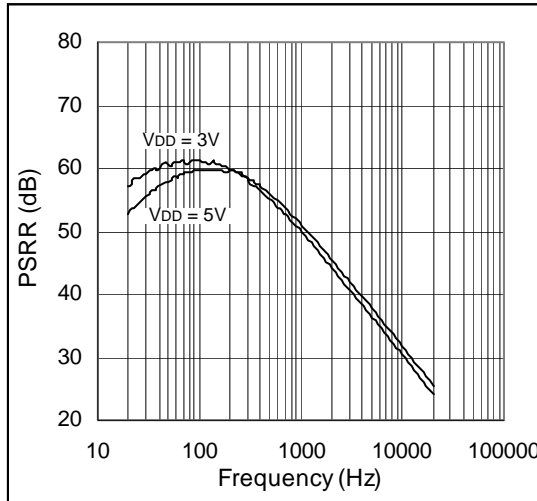

Figure 24. PSRR vs. Frequency; $V_{RIPPLE} = 200\text{mVPP}$, $C_{BP} = C_{IN} = 1\mu\text{F}$, $R_L = 4\Omega$, $A_v = 2$, Floating Input

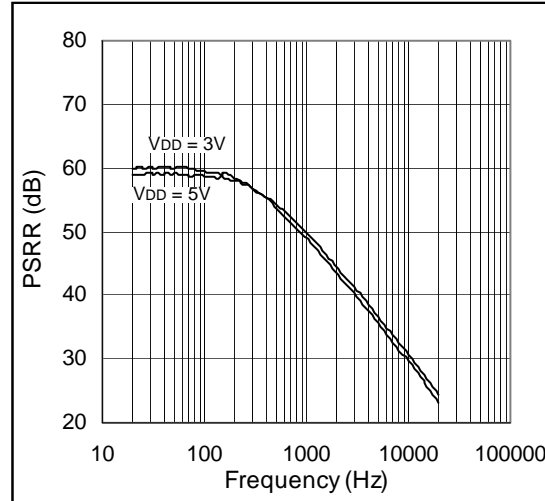

Figure 25. PSRR vs. Frequency; $V_{RIPPLE} = 200\text{mVPP}$, $C_{BP} = C_{IN} = 1\mu\text{F}$, $R_L = 4\Omega$, $A_v = 2$, Inputs Grounded

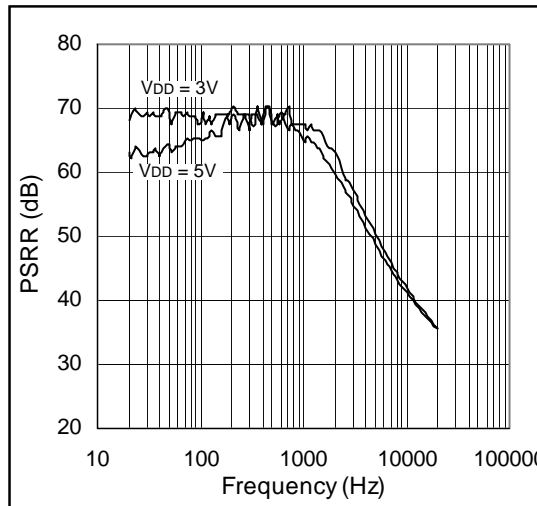

Figure 26. Supply Current vs. Temperature

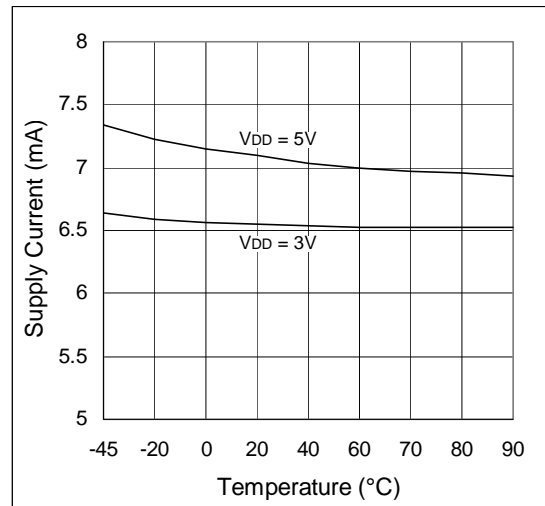

Figure 27. Output Power vs. Load Resistance;
 $V_{DD} = 5V$

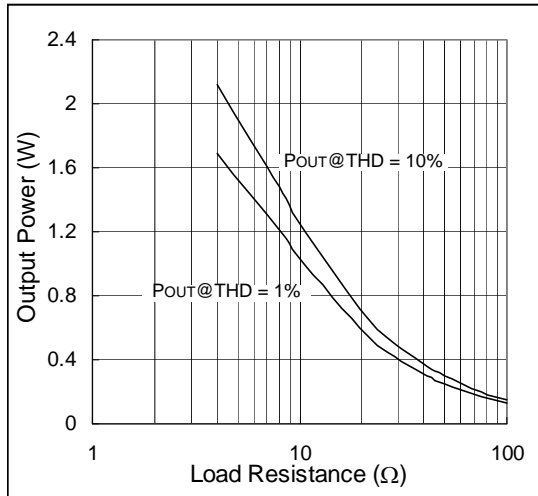
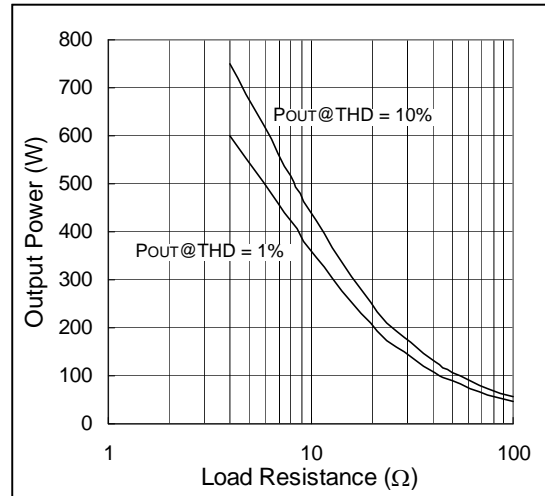

Figure 28. Output Power vs. Load Resistance;
 $V_{DD} = 3V$



8 Detailed Description

The AS1701/AS1706 bridged audio power-amplifiers can deliver 1.6W into 4Ω while operating from a single 2.7 to 5.5V supply. The devices consist of two high-output-current operational amplifiers configured as a bridge-tied load (BTL) amplifier as shown in Figure 29.

Figure 29. AS1701 Typical Configuration Block Diagram

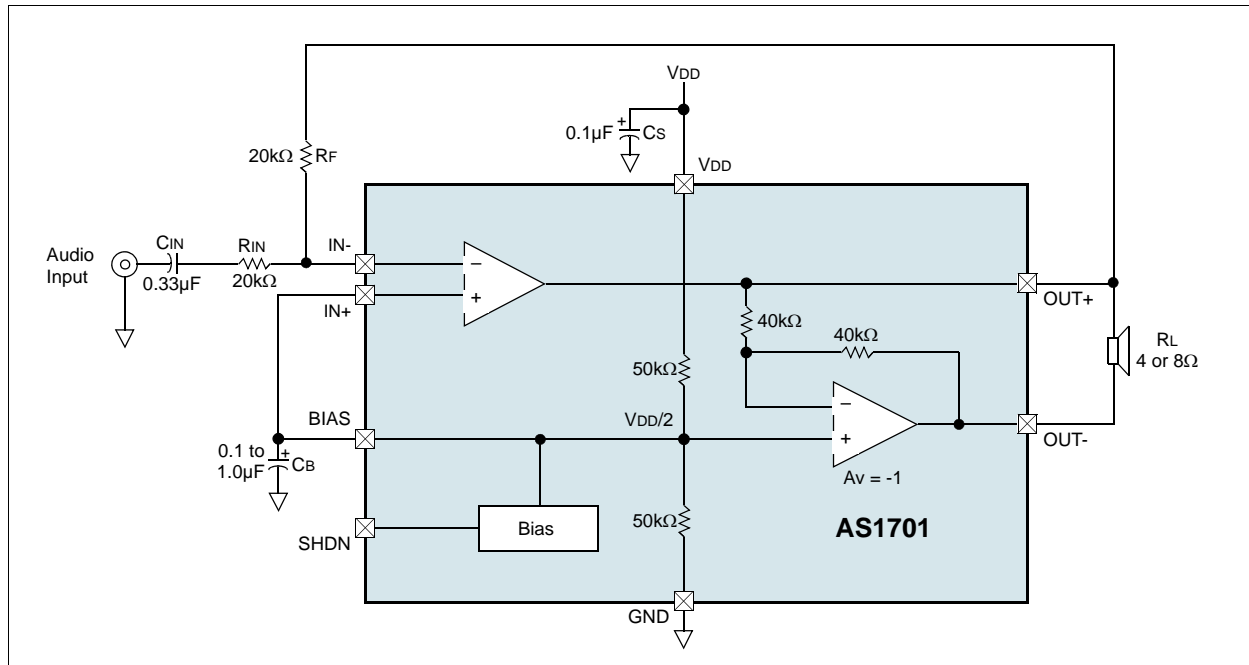

The gain of the devices is set by the closed-loop gain of the input operational amplifier. As shown in Figure 29, the output of the first amplifier serves as the input to the second amplifier, which is configured as an inverting unity-gain follower in both devices. This results in two outputs, identical in magnitude, and 180° out-of-phase.

Bias

The devices operate from a single 2.7 to 5.5V supply and contain an internally generated, common-mode bias voltage of:

$$V_{DD}/2 \quad (EQ 1)$$

referenced to ground. Bias provides click-and-pop suppression and sets the DC bias level for the audio outputs. For selection of the value for the bias bypass capacitor (CBIAS), see [Bias Bypass Capacitor on page 13](#). Pin BIAS is internally connected to the non-inverting input of one amplifier, and should be connected to the non-inverting input of the other amplifier for proper signal biasing (see Figure 29).

Shutdown

The integrated 100nA, low-power shutdown circuitry reduces quiescent current consumption. As shutdown commences, the bias circuitry is automatically disabled, the device outputs go high impedance, and bias is driven to GND.

Note: Connect SHDN to GND for the AS1701 (active-high); connect SHDN to VDD for the AS1706 (active-low).

Current Limit

The AS1701/AS1706 current limit circuitry protects the device during output short-circuit and overload conditions. When both amplifier outputs are shorted to either VDD or GND, the short-circuit protection is enabled and the amplifier enters a pulsing mode, reducing the average output current to a safe level. The amplifier remains in this mode until the short-circuit or overload condition is corrected.

9 Application Information

BTL Amplifier

The AS1701/AS1706 are designed to drive loads differentially in a bridge-tied load (BTL) configuration.

Figure 30. Bridge-Tied Load Configuration

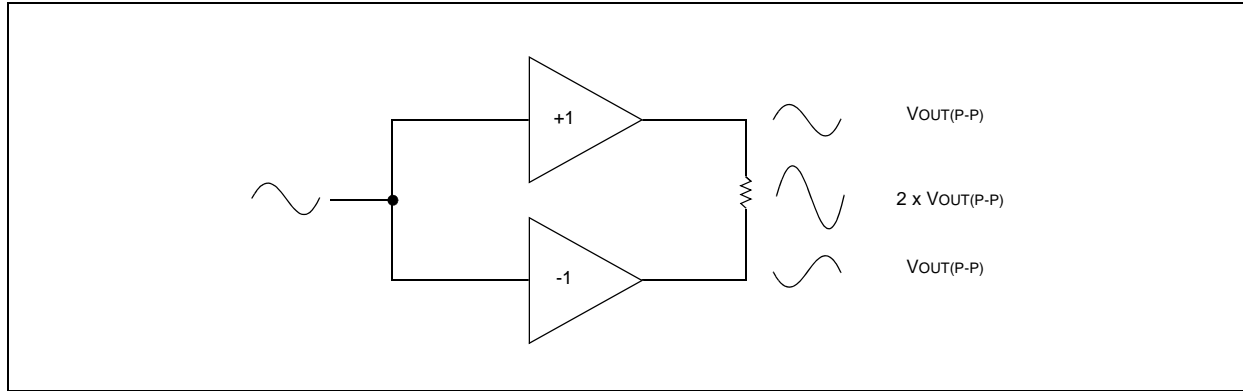

Driving the load differentially doubles the output voltage (illustrated in Figure 30) compared to a single-ended amplifier under similar conditions. Thus, the differential gain of the device is twice the closed-loop gain of the input amplifier. The effective gain is calculated by:

$$AVD = 2 \times \frac{RF}{RIN} \quad (EQ 2)$$

Substituting $2 \times V_{OUT(P-P)}$ into (EQ 3) and (EQ 4) yields four times the output power due to doubling of the output voltage.

$$V_{RMS} = \frac{V_{OUT(P-P)}}{2\sqrt{2}} \quad (EQ 3)$$

$$P_{OUT} = \frac{V_{RMS}^2}{RL} \quad (EQ 4)$$

Since the differential outputs are biased at mid-supply, there is no net DC voltage across the load, eliminating the need for the large, expensive, performance degrading DC-blocking capacitors required by single-ended amplifiers.

Power Dissipation and Heat Sinking

Normally, the devices dissipate a significant amount of power. The maximum power dissipation is given in Table 2 as Continuous Power Dissipation, or it can be calculated by:

$$P_{DISSPKF(MAX)} = \frac{T_{J(MAX)} - T_A}{\Theta_{JA}} \quad (EQ 5)$$

where $T_{J(MAX)}$ is $+150^{\circ}\text{C}$, T_{AMB} (see Table 2) is the ambient temperature, and Θ_{JA} is the reciprocal of the derating factor in $^{\circ}\text{C}/\text{W}$.

The increased power delivered by a BTL configuration normally results in increased internal power dissipation versus a single-ended configuration. The maximum internal power dissipation for a given V_{DD} and load is calculated by:

$$P_{DISSPKF(MAX)} = \frac{2V_{DD}^2}{\pi^2 RL} \quad (EQ 6)$$

If the internal power dissipation exceeds the maximum allowed for a given package, power dissipation can be reduced by increasing the ground plane heat-sinking capabilities and increasing the size of the traces to the device (see Layout and Grounding Considerations on page 14). Additionally, reducing V_{DD} , increasing load impedance, and decreasing ambient temperature can reduce device power dissipation.

The integrated thermal-overload protection circuitry limits the total device power dissipation. Note that if the junction temperature is $\geq +145^{\circ}\text{C}$, the integrated thermal-overload protection circuitry will disable the amplifier output stage. If the junction temperature is reduced by 9°C , the amplifiers will be re-enabled.

Note: A pulsing output under continuous thermal overload results as the device heats and cools.

Efficiency

Efficiency of the AS1701/AS1706 is calculated by taking the ratio of the power delivered to the load, to the power consumed from the power supply. Output power is calculated by:

$$P_{OUT} = \frac{V_{PEAK}^2}{\pi^2 R_L} \quad (\text{EQ 7})$$

where V_{PEAK} is half the peak-to-peak output voltage. In BTL amplifier configurations, the supply current waveform is a full-wave rectified sinusoid with the magnitude proportional to the peak output voltage and load.

Calculate the supply current and power drawn from the power supply by:

$$I_{DD} = \frac{2V_{PEAK}}{\pi R_L} \quad (\text{EQ 8})$$

$$P_{IN} = V_{DD} \frac{2V_{PEAK}}{\pi R_L} \quad (\text{EQ 9})$$

The efficiency of the AS1701/AS1706 is:

$$\eta = \frac{P_{OUT}}{P_{IN}} = \pi \sqrt{\frac{P_{OUT} R_L}{2 V_{DD}^2}} \quad (\text{EQ 10})$$

Component Selection

Gain-Setting Resistors

External feedback resistors R_F and R_{IN} (see Figure 1 on page 1) set the gain of the device as:

$$A_{VD} = 2 \times \frac{R_F}{R_{IN}} \quad (\text{EQ 11})$$

Optimum output offset is achieved when $R_F = 20\text{k}\Omega$. Device gain can be varied by changing the value of R_{IN} .

If used in a high-gain configuration (greater than 8V/V), a feedback capacitor may be required to maintain stability (see Figure 1 on page 1). C_F and R_F limit the bandwidth of the device, preventing high-frequency oscillations.

Note: Ensure that the pole created by C_F and R_F is not within the frequency band of interest.

Input Filter

Input capacitor C_{IN} (if used), in conjunction with R_{IN} , forms a high-pass filter that removes the DC bias from an incoming signal. C_{IN} allows the amplifier to bias the signal to an optimum DC level. Assuming zero source impedance, the -3dB point of the high-pass filter is given by:

$$f_{-3dB} = \frac{1}{2\pi R_{IN} C_{IN}} \quad (\text{EQ 12})$$

Select the value for R_{IN} as specified in [Gain-Setting Resistors on page 12](#). Choose the value for C_{IN} such that f_{-3dB} is well below the lowest frequency of interest. Setting f_{-3dB} too high can affect the low-frequency response of the device. Capacitors with dielectrics that have low-voltage coefficients such as tantalum or aluminum electrolytic should be used, since capacitors with high-voltage coefficients, such as ceramics, can increase distortion at low frequencies.

Note: Other considerations when designing the input filter include the overall constraints of the system, the frequency band of interest, and click-and-pop suppression. Although hi-fi audio specifies a flat gain response between 20Hz and 20kHz, portable voice reproduction devices such as mobile phones and two-way radios only need address the frequency range of the human voice (~ 300Hz to 3.5kHz). Additionally, speakers used in portable devices typically have poor response below 150Hz. In practice, the input filter may not need to be designed for the 20Hz to 20kHz range, which could save PCB space and design costs since only small capacitors would be required.

Bias Bypass Capacitor

The bias bypass capacitor, C_{BIAS} , improves PSRR and THD+N by reducing power supply noise at the common-mode bias node, and serves as the primary click- and pop-suppression component. C_{BIAS} is fed from an internal $25k\Omega$ source, and controls the rate at which the common-mode bias voltage rises at power-up and falls during shutdown. For optimal click- and pop-suppression, ensure that the input capacitor (C_{IN}) is fully charged (ten time constants) before C_{BIAS} .

The value of C_{BIAS} for best click- and pop-suppression is given by:

$$C_{BIAS} \leq 10 \frac{C_{IN} R_{IN}}{25k\Omega} \quad (EQ 13)$$

Note: A larger C_{BIAS} value yields higher PSRR.

Click- and Pop-Less Operation

AC-coupling capacitors (C_{IN}) along with C_{BIAS} facilitate click- and pop-less power-up and shutdown. The value of C_{BIAS} determines the rate at which the mid-rail bias voltage rises on power-up and falls when entering shutdown.

On power-up, C_{IN} is charged to its quiescent DC voltage through the R_F from the output. The current generated creates a voltage transient at the amplifier output, which can result in an audible pop. Minimizing the value of C_{IN} reduces this effect, optimizing click-and-pop suppression.

For more information see [Bias on page 10](#) and [Bias Bypass Capacitor on page 13](#).

Supply Bypassing

Proper power supply bypassing – connect a $0.1\mu F$ ceramic capacitor in parallel with a $10\mu F$ ceramic capacitor from V_{DD} to GND – will ensure low-noise, low-distortion performance of the device. Additional bulk capacitance can be added as required.

Note: Place the capacitors as close to the device as possible.

Volume Control

The addition of a digital potentiometer (AS1500 family) used as an input attenuator, can provide simple volume control for the AS1701/AS1706.

Connect the high terminal of the AS150x to the audio input, the low terminal to ground and the AS150x wiper to C_{IN} (as shown in [Figure 31](#)). Setting the wiper to the top position passes the audio signal unattenuated; setting the wiper to the lowest position fully attenuates the input.

Figure 31. Volume Control Configuration

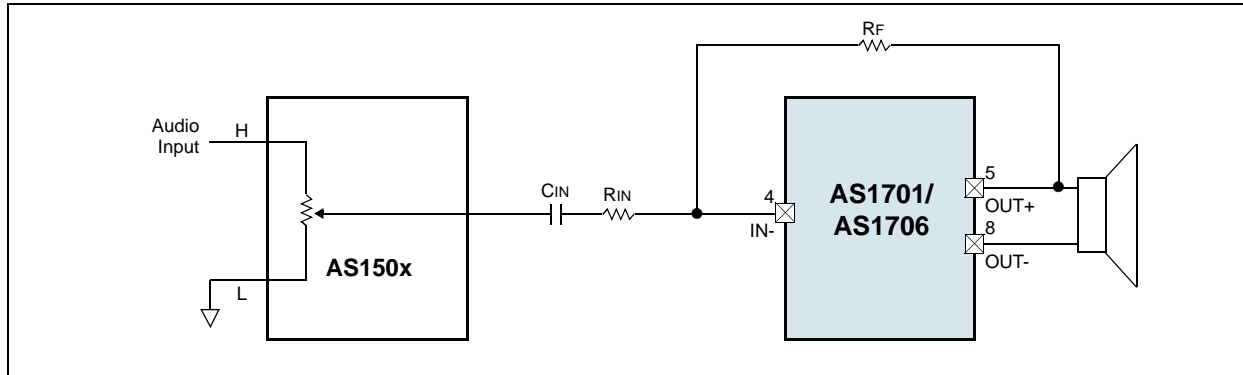

For more information on the AS1500 family of digital potentiometers, refer to the latest version of the AS150x data sheet, available from the austriamicrosystems website <http://www.austriamicrosystems.com>.

Layout and Grounding Considerations

Well designed PC board layout is essential for optimizing device performance. Use large traces for the power supply inputs and amplifier outputs to minimize losses due to parasitic trace resistance and route heat away from the device.

Sufficient grounding improves audio performance, minimizes crosstalk between channels, and prevents digital switching noise from coupling onto the audio signal.

Refer to [Power Dissipation and Heat Sinking on page 11](#) for heat sinking considerations.

10 Package Drawings and Markings

Figure 32. 8-pin MSOP Marking

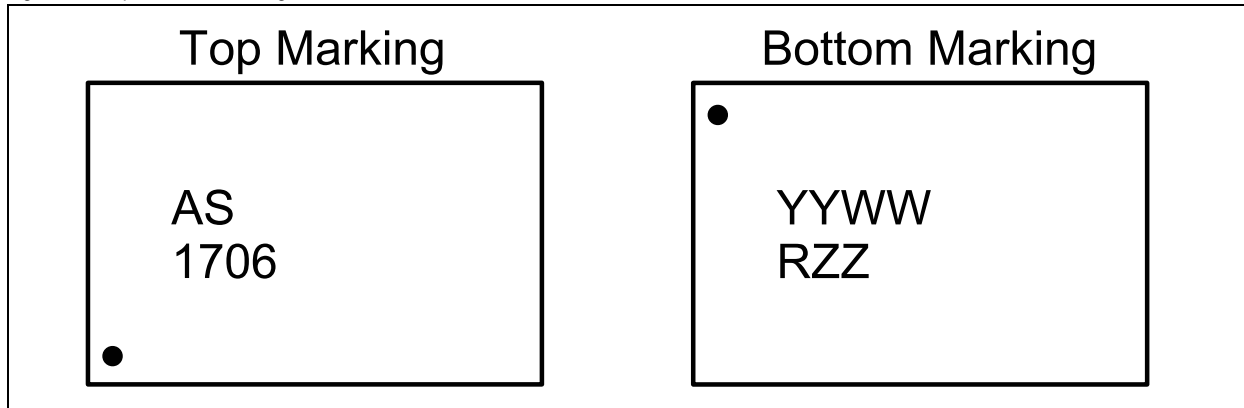
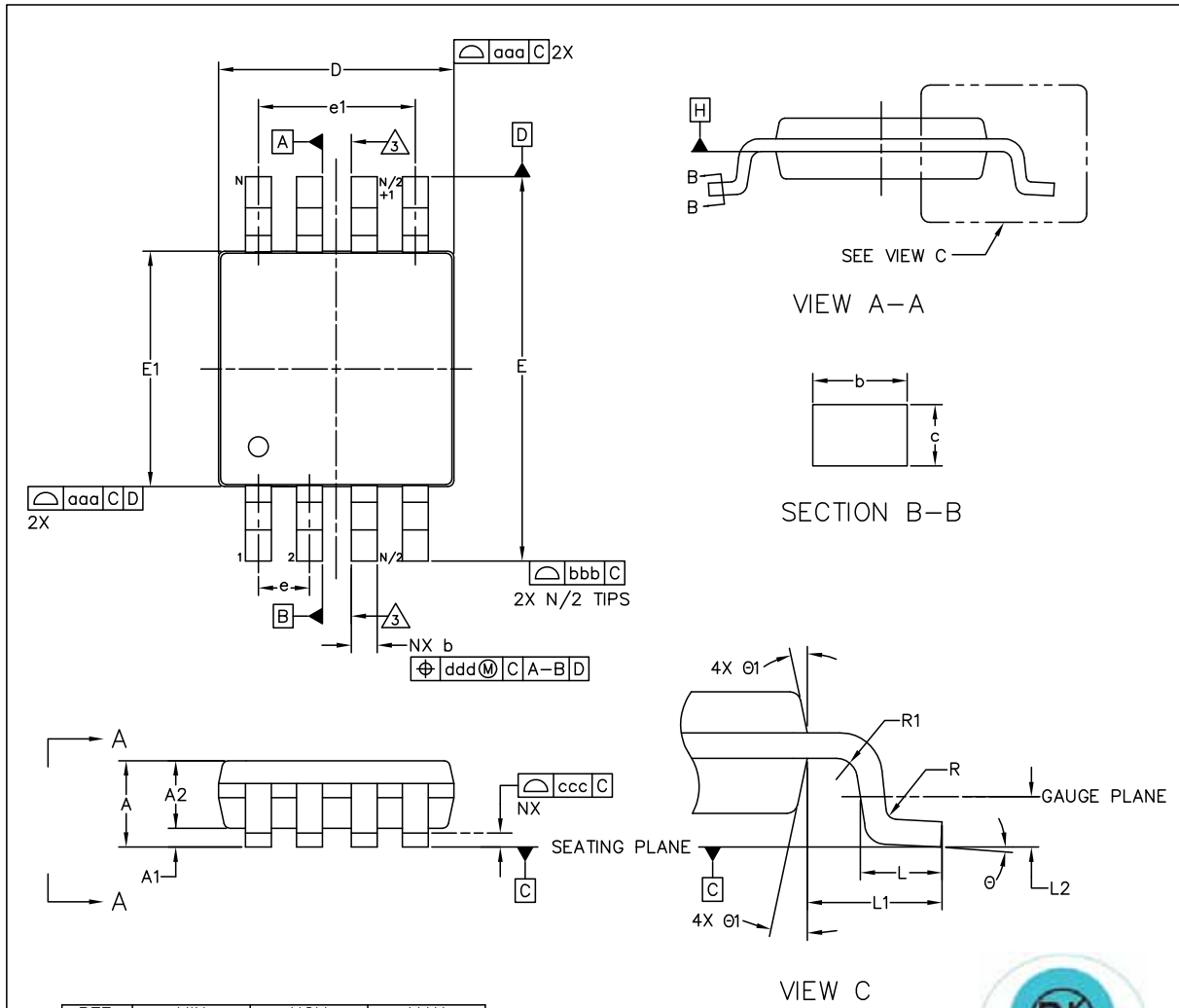

Table 5. Packaging Code YYWWRZZ

YY	WW	R	ZZ
last two digits of the current year	manufacturing week	plant identifier	free choice / traceability code

Figure 33. 8-pin MSOP Package



REF.	MIN	NOM	MAX
A	—	—	1.10
A1	0	—	0.15
A2	0.75	0.85	0.95
b	0.22	—	0.38
c	0.08	—	0.23
D	3.00 BSC		
E	4.90 BSC		
E1	3.00 BSC		
e	0.65 BSC		
e1	1.95 BSC		
L	0.40	0.60	0.80
L1	0.95 REF		
L2	0.25 BSC		
R	0.07	—	—
R1	0.07	—	—
θ	0°	—	8°
θ 1	5°	—	15°
aaa	—	0.20	—
bbb	—	0.25	—
ccc	—	0.10	—
ddd	—	0.13	—
N	8		



NOTE:

- DIMENSIONS & TOLERANCEING CONFIRM TO ASME Y14.5M-1994.
- ALL DIMENSIONS ARE IN MILLIMETERS. ANGELS ARE IN DEGREES.

\triangle DATUMS A & B TO BE DETERMINED AT DATUM H.

			ASSEMBLY ENGINEERING	
a leap ahead in analog			TITLE MSOP 8 LEAD	
DRAWN RH8	DATE 2011.02.04	REV. N/C	REFERENCE DOCUMENT JEDEC MO - 187 LATEST REVISION	
CHECKED GBO	DATE 2011.02.04		DRAWING NO. JAX	UNIT
APPROVED MKR	DATE 2011.02.04	SHEET 1 OF 1	DIMENSION AND TOLERANCE	SCALE NOT IN SCALE

11 Ordering Information

The device is available as the standard products shown in [Table 6](#).

Table 6. Ordering Information

Ordering Code	Marking	Description	SHDN	Delivery Form	Package
AS1701	AS1701	1.6W Audio Power Amplifiers	Active-High	Tube	8-pin MSOP
AS1701-T	AS1701	1.6W Audio Power Amplifiers	Active-High	Tape and Reel	8-pin MSOP
AS1706	AS1706	1.6W Audio Power Amplifiers	Active-Low	Tube	8-pin MSOP
AS1706-T	AS1706	1.6W Audio Power Amplifiers	Active-Low	Tape and Reel	8-pin MSOP

Note: All products are RoHS compliant.

Buy our products or get free samples online at ICdirect: <http://www.austriamicrosystems.com/ICdirect>

Technical Support is found at <http://www.austriamicrosystems.com/Technical-Support>

For further information and requests, please contact us <mailto:sales@austriamicrosystems.com>
or find your local distributor at <http://www.austriamicrosystems.com/distributor>

Copyrights

Copyright © 1997-2011, austriamicrosystems AG, Tobelbaderstrasse 30, 8141 Unterpremstaetten, Austria-Europe. Trademarks Registered ®. All rights reserved. The material herein may not be reproduced, adapted, merged, translated, stored, or used without the prior written consent of the copyright owner.

All products and companies mentioned are trademarks or registered trademarks of their respective companies.

Disclaimer

Devices sold by austriamicrosystems AG are covered by the warranty and patent indemnification provisions appearing in its Term of Sale. austriamicrosystems AG makes no warranty, express, statutory, implied, or by description regarding the information set forth herein or regarding the freedom of the described devices from patent infringement. austriamicrosystems AG reserves the right to change specifications and prices at any time and without notice. Therefore, prior to designing this product into a system, it is necessary to check with austriamicrosystems AG for current information. This product is intended for use in normal commercial applications. Applications requiring extended temperature range, unusual environmental requirements, or high reliability applications, such as military, medical life-support or life-sustaining equipment are specifically not recommended without additional processing by austriamicrosystems AG for each application. For shipments of less than 100 parts the manufacturing flow might show deviations from the standard production flow, such as test flow or test location.

The information furnished here by austriamicrosystems AG is believed to be correct and accurate. However, austriamicrosystems AG shall not be liable to recipient or any third party for any damages, including but not limited to personal injury, property damage, loss of profits, loss of use, interruption of business or indirect, special, incidental or consequential damages, of any kind, in connection with or arising out of the furnishing, performance or use of the technical data herein. No obligation or liability to recipient or any third party shall arise or flow out of austriamicrosystems AG rendering of technical or other services.



Contact Information

Headquarters

austriamicrosystems AG
Tobelbaderstrasse 30
A-8141 Unterpremstaetten, Austria

Tel: +43 (0) 3136 500 0
Fax: +43 (0) 3136 525 01

For Sales Offices, Distributors and Representatives, please visit:

<http://www.austriamicrosystems.com/contact>

Looking for pricing, stock, or lifecycle information?

Click below to explore more details on WIN SOURCE:

- ⊖ [View AS1701 on WIN SOURCE](#)
- ⊖ [OSRAM Opto Semiconductors Inc. Information](#)

Optimize Your Supply Chain with WIN SOURCE Solutions

- ✓ Global Sourcing Solution
- ✓ Obsolete Management
- ✓ Cost Control Management
- ✓ Shortage Management
- ✓ Alternative Solution
- ✓ Excess Inventory Management