



**THE DATASHEET OF  
9ZXL0831AKLFT**



## General Description

The 9ZXL0831 is a low-power 8-output differential buffer that meets all the performance requirements of the Intel DB800ZL specification. It is suitable for PCI-Express Gen1/2/3 or QPI/UPI applications, and uses a fixed external feedback to maintain low drift for demanding QPI/UPI applications.

## Recommended Application

Buffer for Romley, Grantley and Purley Servers, SSD drives and PCIe

## Output Features

- 8 - LP-HCSL Output Pairs

## Features/Benefits

- Low-power push-pull outputs; Save power and board space - no Rp
- Space-saving 48-pin VFQFPN package
- Fixed feedback path for 0ps input-to-output delay
- 8 OE# pins; hardware control of each output
- PLL or bypass mode; PLL can dejitter incoming clock
- 100MHz or 133MHz PLL mode operation; supports PCIe and QPI applications
- Selectable PLL bandwidth; minimizes jitter peaking in downstream PLL's
- Spread Spectrum Compatible; tracks spreading input clock for low EMI

## Key Specifications

- Cycle-to-cycle jitter <50ps
- Output-to-output skew <65 ps
- Input-to-output delay variation <50ps
- PCIe Gen3 phase jitter <1.0ps RMS
- QPI/UPI 9.6GT/s 12UI phase jitter <0.2ps RMS

## Block Diagram

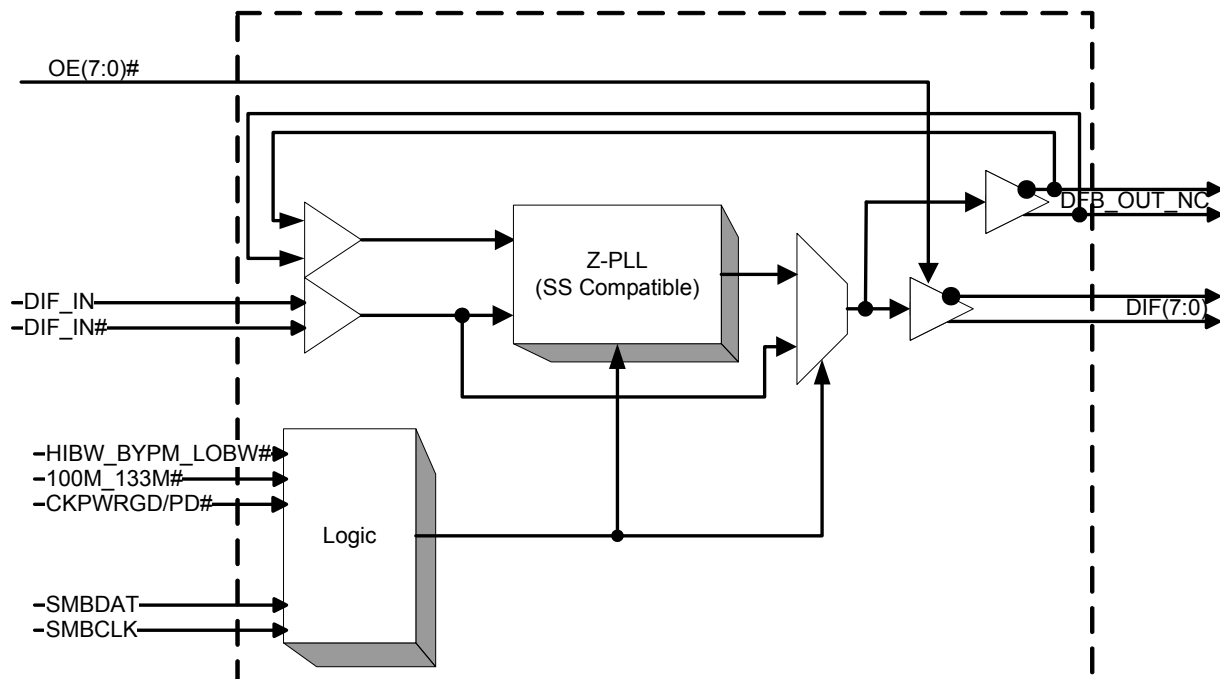

## Pin Configuration

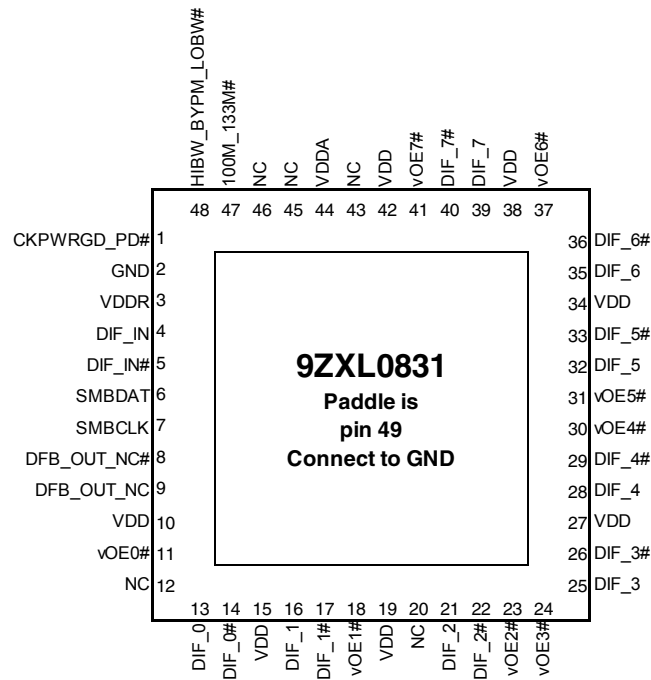

48-pin VFQFPN, 6x6 mm, 0.4mm pitch

## Power Management Table

CKPWRGD_PD#	DIF_IN/ DIF_IN#	SMBus EN bit	DIF(7:0)/ DIF(7:0)#	PLL STATE IF NOT IN BYPASS MODE
0	X	X	Low/Low	OFF
1	Running	0	Low/Low	ON
		1	Running	ON

## Functionality at Power-up (PLL mode)

100M_133M#	DIF_IN MHz	DIF(7:0)
1	100.00	DIF_IN
0	133.33	DIF_IN

## PLL Operating Mode Readback Table

HiBW_BypM_LoBW#	Byte0, bit 7	Byte 0, bit 6
Low (Low BW)	0	0
Mid (Bypass)	0	1
High (High BW)	1	1

## Power Connections

Pin Number		Description
VDD	GND	
44	49	Analog PLL
3	2	Analog Input
10,15,19, 27,34,38, 42	49	DIF clocks

## SMBus Address

Address	+ Read/Write bit
1101100	x

## Tri-Level Input Thresholds

Level	Voltage
Low	<0.8V
Mid	1.2<Vin<1.8V
High	Vin > 2.2V

## PLL Operating Mode

HiBW_BypM_LoBW#	MODE
Low	PLL Lo BW
Mid	Bypass
High	PLL Hi BW

NOTE: PLL is OFF in Bypass Mode

## Pin Descriptions

PIN #	PIN NAME	TYPE	DESCRIPTION
1	CKPWRGD_PD#	IN	3.3V Input notifies device to sample latched inputs and start up on first high assertion, or exit Power Down Mode on subsequent assertions. Low enters Power Down Mode.
2	GND	GND	Ground pin.
3	VDDR	PWR	3.3V power for differential input clock (receiver). This VDD should be treated as an analog power rail and filtered appropriately.
4	DIF_IN	IN	0.7 V Differential True input
5	DIF_IN#	IN	0.7 V Differential Complementary Input
6	SMBDAT	I/O	Data pin of SMBUS circuitry, 5V tolerant
7	SMBCLK	IN	Clock pin of SMBUS circuitry, 5V tolerant
8	DFB_OUT_NC#	OUT	Complementary half of differential feedback output, provides feedback signal to the PLL for synchronization with input clock to eliminate phase error. This pin should NOT be connected on the circuit board, the feedback is internal to the package.
9	DFB_OUT_NC	OUT	True half of differential feedback output, provides feedback signal to the PLL for synchronization with the input clock to eliminate phase error. This pin should NOT be connected on the circuit board, the feedback is internal to the package.
10	VDD	PWR	Power supply, nominal 3.3V
11	vOE0#	IN	Active low input for enabling DIF pair 0. This pin has an internal pull-down. 1 =disable outputs, 0 = enable outputs
12	NC	N/A	No Connection.
13	DIF_0	OUT	0.7V differential true clock output
14	DIF_0#	OUT	0.7V differential Complementary clock output
15	VDD	PWR	Power supply, nominal 3.3V
16	DIF_1	OUT	0.7V differential true clock output
17	DIF_1#	OUT	0.7V differential Complementary clock output
18	vOE1#	IN	Active low input for enabling DIF pair 1. This pin has an internal pull-down. 1 =disable outputs, 0 = enable outputs
19	VDD	PWR	Power supply, nominal 3.3V
20	NC	N/A	No Connection.
21	DIF_2	OUT	0.7V differential true clock output
22	DIF_2#	OUT	0.7V differential Complementary clock output
23	vOE2#	IN	Active low input for enabling DIF pair 2. This pin has an internal pull-down. 1 =disable outputs, 0 = enable outputs
24	vOE3#	IN	Active low input for enabling DIF pair 3. This pin has an internal pull-down. 1 =disable outputs, 0 = enable outputs
25	DIF_3	OUT	0.7V differential true clock output
26	DIF_3#	OUT	0.7V differential Complementary clock output
27	VDD	PWR	Power supply, nominal 3.3V
28	DIF_4	OUT	0.7V differential true clock output
29	DIF_4#	OUT	0.7V differential Complementary clock output
30	vOE4#	IN	Active low input for enabling DIF pair 4. This pin has an internal pull-down. 1 =disable outputs, 0 = enable outputs
31	vOE5#	IN	Active low input for enabling DIF pair 5. This pin has an internal pull-down. 1 =disable outputs, 0 = enable outputs

## Pin Descriptions (cont.)

PIN #	PIN NAME	TYPE	DESCRIPTION
32	DIF_5	OUT	0.7V differential true clock output
33	DIF_5#	OUT	0.7V differential Complementary clock output
34	VDD	PWR	Power supply, nominal 3.3V
35	DIF_6	OUT	0.7V differential true clock output
36	DIF_6#	OUT	0.7V differential Complementary clock output
37	vOE6#	IN	Active low input for enabling DIF pair 6. This pin has an internal pull-down. 1 =disable outputs, 0 = enable outputs
38	VDD	PWR	Power supply, nominal 3.3V
39	DIF_7	OUT	0.7V differential true clock output
40	DIF_7#	OUT	0.7V differential Complementary clock output
41	vOE7#	IN	Active low input for enabling DIF pair 7. This pin has an internal pull-down. 1 =disable outputs, 0 = enable outputs
42	VDD	PWR	Power supply, nominal 3.3V
43	NC	N/A	No Connection.
44	VDDA	PWR	3.3V power for the PLL core.
45	NC	N/A	No Connection.
46	NC	N/A	No Connection.
47	100M_133M#	IN	3.3V Input to select operating frequency. See Functionality Table for Definition
48	HIBW_BYPM_LOBW#	IN	Trilevel input to select High BW, Bypass or Low BW mode. See PLL Operating Mode Table for Details.
49	GND	PWR	Ground

## Absolute Maximum Ratings

Stresses above the ratings listed below can cause permanent damage to the 9ZXL0831. These ratings, which are standard values for IDT commercially rated parts, are stress ratings only. Functional operation of the device at these or any other conditions above those indicated in the operational sections of the specifications is not implied. Exposure to absolute maximum rating conditions for extended periods can affect product reliability. Electrical parameters are guaranteed only over the recommended operating temperature range.

PARAMETER	SYMBOL	CONDITIONS	MIN	TYP	MAX	UNITS	NOTES
3.3V Supply Voltage	VDD, VDDA, VDDR	VDD for core logic and PLL			4.6	V	1,2
Input Low Voltage	V <sub>IL</sub>		GND-0.5			V	1
Input High Voltage	V <sub>IH</sub>	Except for SMBus interface			V <sub>DD</sub> +0.5V	V	1
Input High Voltage	V <sub>IHSMB</sub>	SMBus clock and data pins			5.5V	V	1
Storage Temperature	T <sub>s</sub>		-65		150	°C	1
Junction Temperature	T <sub>j</sub>				125	°C	1
Input ESD protection	ESD prot	Human Body Model	2000			V	1

<sup>1</sup>Guaranteed by design and characterization, not 100% tested in production.

<sup>2</sup>Operation under these conditions is neither implied nor guaranteed.

## Electrical Characteristics—DIF\_IN Clock Input Parameters (HCSL-compatible)

T<sub>A</sub> = T<sub>COM</sub>; Supply Voltage V<sub>DD</sub> = 3.3 V +/-5%

PARAMETER	SYMBOL	CONDITIONS	MIN	TYP	MAX	UNITS	NOTES
Input Crossover Voltage - DIF_IN	V <sub>CROSS</sub>	Cross Over Voltage	150		900	mV	1
Input Swing - DIF_IN	V <sub>SWING</sub>	Differential value	300			mV	1
Input Slew Rate - DIF_IN	dv/dt	Measured differentially	0.4		8	V/ns	1,2
Input Leakage Current	I <sub>IN</sub>	V <sub>IN</sub> = V <sub>DD</sub> , V <sub>IN</sub> = GND	-5		5	uA	
Input Duty Cycle	d <sub>tin</sub>	Measurement from differential waveform	45		55	%	1
Input Jitter - Cycle to Cycle	J <sub>DIFIN</sub>	Differential Measurement	0		125	ps	1

<sup>1</sup>Guaranteed by design and characterization, not 100% tested in production.

<sup>2</sup>Slew rate measured through +/-75mV window centered around differential zero

## Electrical Characteristics–Input/Supply/Common Parameters

$T_A = T_{COM}$ ; Supply Voltage  $V_{DD} = 3.3\text{ V} \pm 5\%$

PARAMETER	SYMBOL	CONDITIONS	MIN	TYP	MAX	UNITS	NOTES
Ambient Operating Temperature	$T_{COM}$	Commercial range	0		70	°C	1
Input High Voltage	$V_{IH}$	Single-ended inputs, except SMBus, low threshold and tri-level inputs	2		$V_{DD} + 0.3$	V	1
Input Low Voltage	$V_{IL}$	Single-ended inputs, except SMBus, low threshold and tri-level inputs	$GND - 0.3$		0.8	V	1
Input Current	$I_{IN}$	Single-ended inputs, $V_{IN} = GND$ , $V_{IN} = V_{DD}$	-5		5	uA	1
	$I_{INP}$	Single-ended inputs $V_{IN} = 0\text{ V}$ ; Inputs with internal pull-up resistors $V_{IN} = V_{DD}$ ; Inputs with internal pull-down resistors	-200		200	uA	1
Input Frequency	$F_{ibyp}$	$V_{DD} = 3.3\text{ V}$ , Bypass mode	33		150	MHz	2
	$F_{ipll}$	$V_{DD} = 3.3\text{ V}$ , 100MHz PLL mode	90	100.00	110	MHz	2
	$F_{ipll}$	$V_{DD} = 3.3\text{ V}$ , 133.33MHz PLL mode	120	133.33	147	MHz	2
Pin Inductance	$L_{pin}$				7	nH	1
Capacitance	$C_{IN}$	Logic Inputs, except DIF_IN	1.5		5	pF	1
	$C_{INDIF\_IN}$	DIF_IN differential clock inputs	1.5		2.7	pF	1,4
	$C_{OUT}$	Output pin capacitance			6	pF	1
Clk Stabilization	$T_{STAB}$	From $V_{DD}$ Power-Up and after input clock stabilization or de-assertion of PD# to 1st clock		0.250	1	ms	1,2
Input SS Modulation Frequency	$f_{MODIN}$	Allowable Frequency (Triangular Modulation)	30		33	kHz	1
OE# Latency	$t_{LATOE\#}$	DIF start after OE# assertion DIF stop after OE# deassertion	4		12	cycles	1,3
Tdrive_PD#	$t_{DRVPD}$	DIF output enable after PD# de-assertion			300	us	1,3
Tfall	$t_F$	Fall time of control inputs			10	ns	1,2
Trise	$t_R$	Rise time of control inputs			10	ns	1,2
SMBus Input Low Voltage	$V_{ILSMB}$				0.8	V	1
SMBus Input High Voltage	$V_{IHSMB}$		2.1		$V_{DDSMB}$	V	1
SMBus Output Low Voltage	$V_{OLSMB}$	@ $I_{PULLUP}$			0.4	V	1
SMBus Sink Current	$I_{PULLUP}$	@ $V_{OL}$	4			mA	1
Nominal Bus Voltage	$V_{DDSMB}$	3V to 5V +/- 10%	2.7		5.5	V	1
SCLK/SDATA Rise Time	$t_{RSMB}$	(Max $V_{IL} - 0.15$ ) to (Min $V_{IH} + 0.15$ )			1000	ns	1
SCLK/SDATA Fall Time	$t_{FSMB}$	(Min $V_{IH} + 0.15$ ) to (Max $V_{IL} - 0.15$ )			300	ns	1
SMBus Operating Frequency	$f_{MAXSMB}$	Maximum SMBus operating frequency			100	kHz	1,5

<sup>1</sup>Guaranteed by design and characterization, not 100% tested in production.

<sup>2</sup>Control input must be monotonic from 20% to 80% of input swing.

<sup>3</sup>Time from deassertion until outputs are >200 mV

<sup>4</sup>DIF\_IN input

<sup>5</sup>The differential input clock must be running for the SMBus to be active

## Electrical Characteristics–DIF 0.7V Low Power Differential Outputs

$T_A = T_{COM}$ ; Supply Voltage  $V_{DD} = 3.3\text{ V} \pm 5\%$

PARAMETER	SYMBOL	CONDITIONS	MIN	TYP	MAX	UNITS	NOTES
Slew rate	Trf	Scope averaging on	2	3.3	4	V/ns	1, 2, 3
Slew rate matching	$\Delta Trf$	Slew rate matching, Scope averaging on		6.8	20	%	1, 2, 4
Voltage High	VHigh	Statistical measurement on single-ended signal using oscilloscope math function. (Scope averaging on)	660	778	850	mV	1
Voltage Low	VLow		-150	0	150		1
Max Voltage	Vmax	Measurement on single ended signal using absolute value. (Scope averaging off)		918	1150	mV	1
Min Voltage	Vmin		-300	-71			1
Vswing	Vswing	Scope averaging off	300	1556	1812	mV	1, 2
Crossing Voltage (abs)	Vcross_abs	Scope averaging off	300	458	550	mV	1, 5
Crossing Voltage (var)	$\Delta V_{cross}$	Scope averaging off		17	140	mV	1, 6

<sup>1</sup>Guaranteed by design and characterization, not 100% tested in production.  $C_L = 2\text{pF}$  with  $R_S = 27\Omega$  for  $Z_0 = 85\Omega$  differential trace impedance).

<sup>2</sup> Measured from differential waveform

<sup>3</sup> Slew rate is measured through the Vswing voltage range centered around differential 0V. This results in a +/-150mV window around differential 0V.

<sup>4</sup> Matching applies to rising edge rate for Clock and falling edge rate for Clock#. It is measured using a +/-75mV window centered on the average cross point where Clock rising meets Clock# falling. The median cross point is used to calculate the voltage thresholds the oscilloscope is to use for the edge rate calculations.

<sup>5</sup> Vcross is defined as voltage where Clock = Clock# measured on a component test board and only applies to the differential rising edge (i.e. Clock rising and Clock# falling).

<sup>6</sup> The total variation of all Vcross measurements in any particular system. Note that this is a subset of Vcross\_min/max (Vcross absolute) allowed. The intent is to limit Vcross induced modulation by setting  $\Delta V_{cross}$  to be smaller than Vcross absolute.

## Electrical Characteristics–Current Consumption

$T_A = T_{COM}$ ; Supply Voltage  $V_{DD} = 3.3\text{ V} \pm 5\%$

PARAMETER	SYMBOL	CONDITIONS	MIN	TYP	MAX	UNITS	NOTES
Operating Current	$I_{DDVDD}$	133MHz, VDD rail		59	75	mA	1
	$I_{DDVDDA}$	133MHz, VDDA + VDDR rail, PLL Mode		19	25	mA	1
Powerdown Current	$I_{DDVDDPD}$	Power Down, VDD Rail		1.2	2	mA	1
	$I_{DDVDDAPD}$	Power Down, VDDA Rail		2.5	5	mA	1

<sup>1</sup>Guaranteed by design and characterization, not 100% tested in production.

<sup>2</sup>  $C_L = 2\text{pF}$  with  $R_S = 27\Omega$  for  $Z_0 = 85\Omega$  differential trace impedance

## Electrical Characteristics—Skew and Differential Jitter Parameters

$T_A = T_{COM}$ ; Supply Voltage  $V_{DD} = 3.3\text{ V} \pm 5\%$

PARAMETER	SYMBOL	CONDITIONS	MIN	TYP	MAX	UNITS	NOTES
CLK_IN, DIF[x:0]	$t_{SPO\_PLL}$	Input-to-Output Skew in PLL mode nominal value @ 25°C, 3.3V	-100	-60	100	ps	1,2,4,5,8
CLK_IN, DIF[x:0]	$t_{PD\_BYP}$	Input-to-Output Skew in Bypass mode nominal value @ 25°C, 3.3V	2.5	3.2	4.5	ns	1,2,3,5,8
CLK_IN, DIF[x:0]	$t_{DSPO\_PLL}$	Input-to-Output Skew Variation in PLL mode across voltage and temperature	-50		50	ps	1,2,3,5,8
CLK_IN, DIF[x:0]	$t_{DSPO\_BYP}$	Input-to-Output Skew Variation in Bypass mode across voltage and temperature	-250		250	ps	1,2,3,5,8
CLK_IN, DIF[x:0]	$t_{DTE}$	Random Differential Tracking error between two 9ZX devices in Hi BW Mode		1	5	ps (rms)	1,2,3,5,8
CLK_IN, DIF[x:0]	$t_{DSSTE}$	Random Differential Spread Spectrum Tracking error between two 9ZX devices in Hi BW Mode		5	75	ps	1,2,3,5,8
DIF{x:0}	$t_{SKEW\_ALL}$	Output-to-Output Skew across all outputs (Common to Bypass and PLL mode)		53	65	ps	1,2,3,8
PLL Jitter Peaking	$j_{peak-hibw}$	LOBW#_BYPASS_HIBW = 1	0	1.2	2.5	dB	7,8
PLL Jitter Peaking	$j_{peak-lobw}$	LOBW#_BYPASS_HIBW = 0	0	0.76	2	dB	7,8
PLL Bandwidth	$p_{ll\_HIBW}$	LOBW#_BYPASS_HIBW = 1	2	3	4	MHz	8,9
PLL Bandwidth	$p_{ll\_LOBW}$	LOBW#_BYPASS_HIBW = 0	0.7	1.1	1.4	MHz	8,9
Duty Cycle	$t_{DC}$	Measured differentially, PLL Mode	45	50.1	55	%	1
Duty Cycle Distortion	$t_{DCD}$	Measured differentially, Bypass Mode @ 100MHz	-2	0	2	%	1,10
Jitter, Cycle to cycle	$t_{jyc-cyc}$	PLL mode		34	50	ps	1,11
		Additive Jitter in Bypass Mode		17	50	ps	1,11

### Notes for preceding table:

- <sup>1</sup>  $C_L = 2\text{pF}$  with  $R_S = 27\Omega$  for  $Z_0 = 85\Omega$  differential trace impedance. Input to output skew is measured at the first output edge following the corresponding input.
- <sup>2</sup> Measured from differential cross-point to differential cross-point. This parameter can be tuned with external feedback path, if present.
- <sup>3</sup> All Bypass Mode Input-to-Output specs refer to the timing between an input edge and the specific output edge created by it.
- <sup>4</sup> This parameter is deterministic for a given device
- <sup>5</sup> Measured with scope averaging on to find mean value.
- <sup>6</sup>  $t$  is the period of the input clock
- <sup>7</sup> Measured as maximum pass band gain. At frequencies within the loop BW, highest point of magnification is called PLL jitter peaking.
- <sup>8</sup> Guaranteed by design and characterization, not 100% tested in production.
- <sup>9</sup> Measured at 3 db down or half power point.
- <sup>10</sup> Duty cycle distortion is the difference in duty cycle between the output and the input clock when the device is operated in bypass mode.
- <sup>11</sup> Measured from differential waveform

## Electrical Characteristics–Phase Jitter Parameters

$T_A = T_{COM}$ ; Supply Voltage  $V_{DD} = 3.3\text{ V} \pm 5\%$

PARAMETER	SYMBOL	CONDITIONS	MIN	TYP	MAX	UNITS	Notes
Phase Jitter, PLL Mode	$t_{jphPCleG1}$	PCIe Gen 1		34	86	ps (p-p)	1,2,3
	$t_{jphPCleG2}$	PCIe Gen 2 Lo Band 10kHz < f < 1.5MHz		1.2	3	ps (rms)	1,2
		PCIe Gen 2 High Band 1.5MHz < f < Nyquist (50MHz)		2.2	3.1	ps (rms)	1,2
	$t_{jphPCleG3}$	PCIe Gen 3 (PLL BW of 2-4MHz, CDR = 10MHz)		0.5	1	ps (rms)	1,2,4
	$t_{jphQPI\_SMI}$	QPI & SMI (100MHz or 133MHz, 4.8Gb/s, 6.4Gb/s 12UI)		0.24	0.5	ps (rms)	1,5
		QPI & SMI (100MHz, 8.0Gb/s, 12UI)		0.14	0.3	ps (rms)	1,5
		QPI & SMI (100MHz, 9.6Gb/s, 12UI)		0.12	0.2	ps (rms)	1,5
Additive Phase Jitter, Bypass mode	$t_{jphPCleG1}$	PCIe Gen 1		3.7	10	ps (p-p)	1,2,3
	$t_{jphPCleG2}$	PCIe Gen 2 Lo Band 10kHz < f < 1.5MHz		0.1	0.3	ps (rms)	1,2,6
		PCIe Gen 2 High Band 1.5MHz < f < Nyquist (50MHz)		0.4	0.6	ps (rms)	1,2,6
	$t_{jphPCleG3}$	PCIe Gen 3 (PLL BW of 2-4MHz, 2-5MHz, CDR = 10MHz)		0.00	0.2	ps (rms)	1,2,4,6
	$t_{jphQPI\_SMI}$	QPI & SMI (100MHz or 133MHz, 4.8Gb/s, 6.4Gb/s 12UI)		0.14	0.2	ps (rms)	1,5,6
		QPI & SMI (100MHz, 8.0Gb/s, 12UI)		0.00	0.1	ps (rms)	1,5,6
QPI & SMI (100MHz, 9.6Gb/s, 12UI)			0.00	0.1	ps (rms)	1,5,6	

<sup>1</sup> Applies to all outputs.

<sup>2</sup> See <http://www.pcisig.com> for complete specs

<sup>3</sup> Sample size of at least 100K cycles. This figures extrapolates to 108ps pk-pk @ 1M cycles for a BER of 1-12.

<sup>4</sup> Subject to final ratification by PCI SIG.

<sup>5</sup> Calculated from Intel-supplied Clock Jitter Tool v 1.6.3

<sup>6</sup> For RMS figures, additive jitter is calculated by solving the following equation:  $(\text{Additive jitter})^2 = (\text{total jitter})^2 - (\text{input jitter})^2$

## Clock Periods–Differential Outputs with Spread Spectrum Disabled

SSC OFF	Center Freq. MHz	Measurement Window							Units	Notes
		1 Clock	1us	0.1s	0.1s	0.1s	1us	1 Clock		
		-c2c jitter AbsPer Min	-SSC Short-Term Average Min	- ppm Long-Term Average Min	0 ppm Period Nominal	+ ppm Long-Term Average Max	+SSC Short-Term Average Max	+c2c jitter AbsPer Max		
DIF	100.00	9.94900		9.99900	10.00000	10.00100		10.05100	ns	1,2,3
	133.33	7.44925		7.49925	7.50000	7.50075		7.55075	ns	1,2,4

## Clock Periods–Differential Outputs with Spread Spectrum Enabled

SSC ON	Center Freq. MHz	Measurement Window							Units	Notes
		1 Clock	1us	0.1s	0.1s	0.1s	1us	1 Clock		
		-c2c jitter AbsPer Min	-SSC Short-Term Average Min	- ppm Long-Term Average Min	0 ppm Period Nominal	+ ppm Long-Term Average Max	+SSC Short-Term Average Max	+c2c jitter AbsPer Max		
DIF	99.75	9.94906	9.99906	10.02406	10.02506	10.02607	10.05107	10.10107	ns	1,2,3
	133.00	7.44930	7.49930	7.51805	7.51880	7.51955	7.53830	7.58830	ns	1,2,4

### Notes:

<sup>1</sup>Guaranteed by design and characterization, not 100% tested in production.

<sup>2</sup>All Long Term Accuracy specifications are guaranteed with the assumption that the input clock complies with CK420BQ/CK410B+ accuracy requirements (+/-100ppm). The device itself does not contribute to ppm error.

<sup>3</sup> Driven by SRC output of main clock, 100 MHz PLL Mode or Bypass mode

<sup>4</sup> Driven by CPU output of main clock, 133 MHz PLL Mode or Bypass mode

## Test Loads

### Differential Output Terminations

DIF Zo ( $\Omega$ )	Rs ( $\Omega$ )
100	33
85	27

### Differential Test Loads

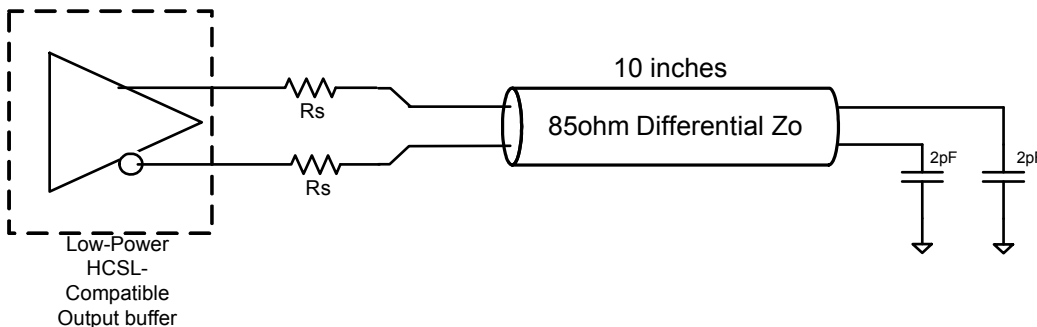

## General SMBus Serial Interface Information for 9ZXL0831

### How to Write

- Controller (host) sends a start bit
- Controller (host) sends the write address
- IDT clock will **acknowledge**
- Controller (host) sends the beginning byte location = N
- IDT clock will **acknowledge**
- Controller (host) sends the byte count = X
- IDT clock will **acknowledge**
- Controller (host) starts sending Byte N through Byte N+X-1
- IDT clock will **acknowledge** each byte **one at a time**
- Controller (host) sends a Stop bit

Index Block Write Operation		
Controller (Host)		IDT (Slave/Receiver)
T	starT bit	
Slave Address		
WR	WRite	
Beginning Byte = N		ACK
Data Byte Count = X		ACK
Beginning Byte N		ACK
O	X Byte	O
O		O
O		O
Byte N + X - 1		ACK
P	stoP bit	

### How to Read

- Controller (host) will send a start bit
- Controller (host) sends the write address
- IDT clock will **acknowledge**
- Controller (host) sends the beginning byte location = N
- IDT clock will **acknowledge**
- Controller (host) will send a separate start bit
- Controller (host) sends the read address
- IDT clock will **acknowledge**
- IDT clock will send the data byte count = X
- IDT clock sends Byte N+X-1
- IDT clock sends **Byte 0 through Byte X (if X<sub>(H)</sub> was written to Byte 8)**
- Controller (host) will need to acknowledge each byte
- Controller (host) will send a not acknowledge bit
- Controller (host) will send a stop bit

Index Block Read Operation		
Controller (Host)		IDT (Slave/Receiver)
T	starT bit	
Slave Address		
WR	WRite	
Beginning Byte = N		ACK
Repeat starT		ACK
Slave Address		
RD	ReaD	
Data Byte Count=X		ACK
Beginning Byte N		ACK
ACK		X Byte
ACK		
O		
O		
O		
Byte N + X - 1		
N	Not acknowledge	
P	stoP bit	

**SMBusTable: PLL Mode, and Frequency Select Register**

Byte 0	Pin #	Name	Control Function	Type	0	1	Default
Bit 7	48	PLL Mode 1	PLL Operating Mode Rd back 1	R	See PLL Operating Mode Readback Table		Latch
Bit 6	48	PLL Mode 0	PLL Operating Mode Rd back 0	R			Latch
Bit 5			Reserved				0
Bit 4			Reserved				0
Bit 3		PLL SW EN	Enable S/W control of PLL BW	RW	HW Latch	SMBus Control	0
Bit 2		PLL Mode 1	PLL Operating Mode 1	RW	See PLL Operating Mode Readback Table		1
Bit 1		PLL Mode 0	PLL Operating Mode 0	RW			1
Bit 0	47	100M 133M#	Frequency Select Readback	R	133MHz	100MHz	Latch

**Note:** Setting bit 3 to '1' allows the user to override the Latch value from pin 5 via use of bits 2 and 1. Use the values from the PLL Operating Mode Readback Table. Note that Bits 7 and 6 will keep the value originally latched on pin 5. A warm reset of the system will have to be accomplished if the user changes these bits.

**SMBusTable: Output Control Register**

Byte 1	Pin #	Name	Control Function	Type	0	1	Default
Bit 7	32/33	DIF 5 En	Output Control - '0' overrides OE# pin	RW	Low/Low	Enable	1
Bit 6	28/29	DIF 4 En	Output Control - '0' overrides OE# pin	RW			1
Bit 5	25/26	DIF 3 En	Output Control - '0' overrides OE# pin	RW			1
Bit 4	21/22	DIF 2 En	Output Control - '0' overrides OE# pin	RW			1
Bit 3			Reserved				1
Bit 2	16/17	DIF 1 En	Output Control - '0' overrides OE# pin	RW	Low/Low	Enable	1
Bit 1	13/14	DIF 0 En	Output Control - '0' overrides OE# pin	RW			1
Bit 0			Reserved				1

**SMBusTable: Output Control Register**

Byte 2	Pin #	Name	Control Function	Type	0	1	Default
Bit 7			Reserved				0
Bit 6			Reserved				0
Bit 5			Reserved				0
Bit 4			Reserved				0
Bit 3			Reserved				1
Bit 2	39/40	DIF 7 En	Output Control - '0' overrides OE# pin	RW	Low/Low	Enable	1
Bit 1			Reserved				1
Bit 0	35/36	DIF 6 En	Output Control - '0' overrides OE# pin	RW	Low/Low	Enable	1

**SMBusTable: Reserved Register**

Byte 3	Pin #	Name	Control Function	Type	0	1	Default
Bit 7			Reserved				0
Bit 6			Reserved				0
Bit 5			Reserved				0
Bit 4			Reserved				0
Bit 3			Reserved				0
Bit 2			Reserved				0
Bit 1			Reserved				0
Bit 0			Reserved				0

**SMBusTable: Reserved Register**

Byte 4	Pin #	Name	Control Function	Type	0	1	Default
Bit 7			Reserved				0
Bit 6			Reserved				0
Bit 5			Reserved				0
Bit 4			Reserved				0
Bit 3			Reserved				0
Bit 2			Reserved				0
Bit 1			Reserved				0
Bit 0			Reserved				0

SMBusTable: Vendor &amp; Revision ID Register

Byte 5	Pin #	Name	Control Function	Type	0	1	Default
Bit 7	-	RID3	REVISION ID	R	A rev = 0000		X
Bit 6	-	RID2		R			X
Bit 5	-	RID1		R			X
Bit 4	-	RID0		R			X
Bit 3	-	VID3	VENDOR ID	R	-	-	0
Bit 2	-	VID2		R	-	-	0
Bit 1	-	VID1		R	-	-	0
Bit 0	-	VID0		R	-	-	1

SMBusTable: DEVICE ID

Byte 6	Pin #	Name	Control Function	Type	0	1	Default
Bit 7	-	Device ID 7 (MSB)		R	0831 is 231 Decimal or E7 Hex		1
Bit 6	-	Device ID 6		R			1
Bit 5	-	Device ID 5		R			1
Bit 4	-	Device ID 4		R			0
Bit 3	-	Device ID 3		R			0
Bit 2	-	Device ID 2		R			1
Bit 1	-	Device ID 1		R			1
Bit 0	-	Device ID 0		R			1

SMBusTable: Byte Count Register

Byte 7	Pin #	Name	Control Function	Type	0	1	Default
Bit 7			Reserved				0
Bit 6			Reserved				0
Bit 5			Reserved				0
Bit 4	-	BC4	Writing to this register configures how many bytes will be read back.	RW	Default value is 8 hex, so 9 bytes (0 to 8) will be read back by default.		0
Bit 3	-	BC3		RW			1
Bit 2	-	BC2		RW			0
Bit 1	-	BC1		RW			0
Bit 0	-	BC0		RW			0

SMBusTable: Reserved Register

Byte 8	Pin #	Name	Control Function	Type	0	1	Default
Bit 7			Reserved				0
Bit 6			Reserved				0
Bit 5			Reserved				0
Bit 4			Reserved				0
Bit 3			Reserved				0
Bit 2			Reserved				0
Bit 1			Reserved				0
Bit 0			Reserved				0

## Marking Diagram

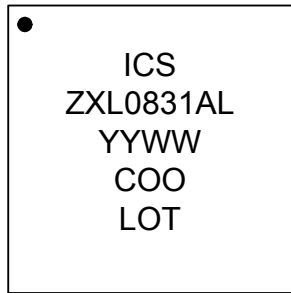

### Notes:

1. "L" denotes RoHS compliant package.
2. "YYWW" is the last two digits of the year and week that the part was assembled.
3. "COO": country of origin.
4. "LOT" denotes the lot number.



Package Outline and Package Dimensions (NDG48), cont. Use Epad 4.2mm Sq.

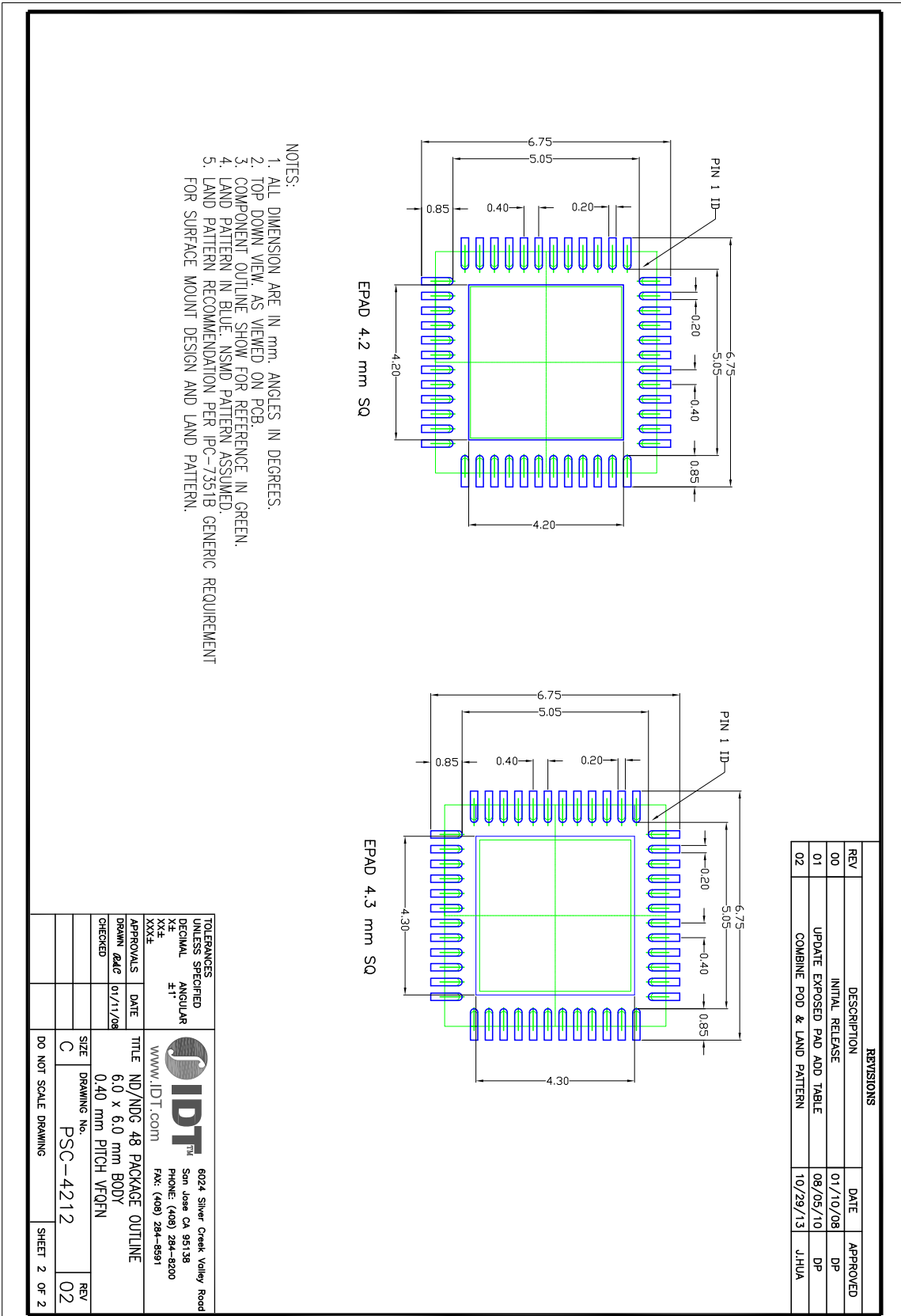

## Ordering Information

Part / Order Number	Shipping Package	Package	Temperature
9ZXL0831AKLF	Trays	48-VFQFN	0 to +70°C
9ZXL0831AKLFT	Tape and Reel	48-VFQFN	0 to +70°C

"LF" suffix to the part number are the Pb-Free configuration and are RoHS compliant.

"A" is the device revision designator (will not correlate with the datasheet revision).

While the information presented herein has been checked for both accuracy and reliability, Integrated Device Technology (IDT) assumes no responsibility for either its use or for the infringement of any patents or other rights of third parties, which would result from its use. No other circuits, patents, or licenses are implied. This product is intended for use in normal commercial applications. Any other applications such as those requiring extended temperature range, high reliability, or other extraordinary environmental requirements are not recommended without additional processing by IDT. IDT does not authorize or warrant any IDT product for use in life support devices or critical medical instruments.

## Revision History

Rev.	Issuer	Issue Date	Description	Page #
A	RDW	10/21/2013	Updated electrical tables with Char data. Move to final	Various
B	RDW	7/30/2014	Changed DB1200ZL reference in "general description" to DB800ZL	1
C	RDW	7/1/2015	Updated POD drawing.	15
D	RDW	11/20/2015	1. Updated QPI references to QPI/UPI 2. Updated DIF_IN table to match PCI SIG specification, no silicon change	1,5
E	RDW	8/16/2016	Corrected typos in package ordering information	17

**Innovate with IDT and accelerate your future networks. Contact:**

[www.IDT.com](http://www.IDT.com)

**For Sales**

800-345-7015  
408-284-8200  
Fax: 408-284-2775

**For Tech Support**

[www.idt.com/go/support](http://www.idt.com/go/support)

---

**Corporate Headquarters**

Integrated Device Technology, Inc.  
[www.idt.com](http://www.idt.com)



## Looking for pricing, stock, or lifecycle information?

Click below to explore more details on WIN SOURCE:

-  [View 9ZXL0831AKLFT on WIN SOURCE](#)
-  [IDT, Integrated Device Technology Inc Information](#)

## Optimize Your Supply Chain with WIN SOURCE Solutions

-  Global Sourcing Solution
-  Obsolete Management
-  Cost Control Management
-  Shortage Management
-  Alternative Solution
-  Excess Inventory Management