



**THE DATASHEET OF
CY7C1019D-10ZSXI**



Features

- Pin- and function-compatible with CY7C1019B
- High speed
 - $t_{AA} = 10 \text{ ns}$
- Low active power
 - $I_{CC} = 80 \text{ mA @ } 10 \text{ ns}$
- Low CMOS standby power
 - $I_{SB2} = 3 \text{ mA}$
- 2.0 V Data retention
- Automatic power-down when deselected
- CMOS for optimum speed/power
- Center power/ground pinout
- Easy memory expansion with \overline{CE} and \overline{OE} options
- Functionally equivalent to CY7C1019B
- Available in Pb-free 32-pin 400-Mil wide Molded SOJ and 32-pin TSOP II packages

Functional Description

The CY7C1019D ^[1] is a high-performance CMOS static RAM organized as 131,072 words by 8 bits. Easy memory expansion is provided by an active LOW Chip Enable (\overline{CE}), an active LOW Output Enable (\overline{OE}), and tri-state drivers. This device has an automatic power-down feature that significantly reduces power consumption when deselected. The eight input and output pins (IO₀ through IO₇) are placed in a high-impedance state when:

- Deselected (\overline{CE} HIGH)
- Outputs are disabled (\overline{OE} HIGH)
- When the write operation is active (\overline{CE} LOW, and \overline{WE} LOW).

Write to the device by taking Chip Enable (\overline{CE}) and Write Enable (\overline{WE}) inputs LOW. Data on the eight IO pins (IO₀ through IO₇) is then written into the location specified on the address pins (A₀ through A₁₆).

Read from the device by taking Chip Enable (\overline{CE}) and Output Enable (\overline{OE}) LOW while forcing Write Enable (\overline{WE}) HIGH. Under these conditions, the contents of the memory location specified by the address pins appears on the IO pins.

The CY7C1019D device is suitable for interfacing with processors that have TTL I/P levels. It is not suitable for processors that require CMOS I/P levels. Please see [Electrical Characteristics on page 4](#) for more details and suggested alternatives.

For a complete list of related documentation, [click here](#).

Logic Block Diagram

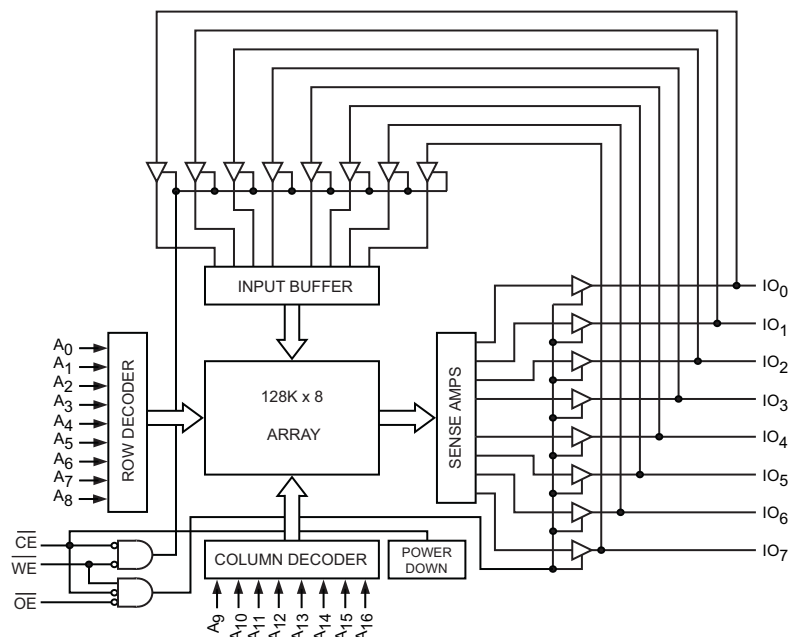

Note

1. For guidelines on SRAM system design, please refer to the 'System Design Guidelines' Cypress application note, available on the internet at www.cypress.com.

Contents

Pin Configuration	3	Ordering Information	11
Selection Guide	3	Ordering Code Definitions	11
Maximum Ratings	4	Package Diagrams	12
Operating Range	4	Acronyms	14
Electrical Characteristics	4	Document Conventions	14
Capacitance	5	Units of Measure	14
Thermal Resistance	5	Document History Page	15
AC Test Loads and Waveforms	5	Sales, Solutions, and Legal Information	16
Data Retention Characteristics	6	Worldwide Sales and Design Support	16
Data Retention Waveform	6	Products	16
Switching Characteristics	7	PSoC® Solutions	16
Switching Waveforms	8	Cypress Developer Community	16
Truth Table	11	Technical Support	16

Pin Configuration

Figure 1. 32-pin SOJ / TSOP II pinout (Top View)

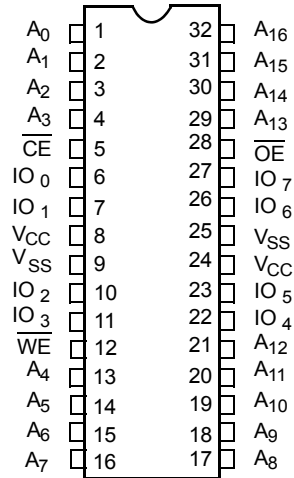

Selection Guide

Description	-10 (Industrial)	Unit
Maximum Access Time	10	ns
Maximum Operating Current	80	mA
Maximum Standby Current	3	mA

Maximum Ratings

Exceeding the maximum ratings may impair the useful life of the device. These user guidelines are not tested.

Storage Temperature	-65 °C to +150 °C
Ambient Temperature with Power Applied	-55 °C to +125 °C
Supply Voltage on V _{CC} to Relative GND [2]	-0.5 V to +6.0 V
DC Voltage Applied to Outputs in High Z State [2]	-0.5 V to V _{CC} + 0.5 V

DC Input Voltage [2]	-0.5 V to V _{CC} + 0.5 V
Current into Outputs (LOW)	20 mA
Static Discharge Voltage (per MIL-STD-883, Method 3015)	> 2001 V
Latch-up Current	> 200 mA

Operating Range

Range	Ambient Temperature	V _{CC}	Speed
Industrial	-40 °C to +85 °C	5 V ± 0.5 V	10 ns

Electrical Characteristics

Over the Operating Range

Parameter	Description	Test Conditions	-10 (Industrial)		Unit	
			Min	Max		
V _{OH}	Output HIGH Voltage	I _{OH} = -4.0 mA	2.4	-	V	
		I _{OH} = -0.1 mA	-	3.4 [3]		
V _{OL}	Output LOW Voltage	I _{OL} = 8.0 mA	-	0.4	V	
V _{IH}	Input HIGH Voltage		2.2	V _{CC} + 0.5	V	
V _{IL}	Input LOW Voltage [2]		-0.5	0.8	V	
I _{IX}	Input Leakage Current	GND ≤ V _I ≤ V _{CC}	-1	+1	μA	
I _{OZ}	Output Leakage Current	GND ≤ V _I ≤ V _{CC} , Output Disabled	-1	+1	μA	
I _{CC}	V _{CC} Operating Supply Current	V _{CC} = Max, I _{OUT} = 0 mA, f = f _{max} = 1/t _{RC}	100 MHz	-	80	mA
			83 MHz	-	72	mA
			66 MHz	-	58	mA
			40 MHz	-	37	mA
I _{SB1}	Automatic CE Power-Down Current – TTL Inputs	Max V _{CC} , $\overline{CE} \geq V_{IH}$, V _{IN} ≥ V _{IH} or V _{IN} ≤ V _{IL} , f = f _{max}	-	10	mA	
I _{SB2}	Automatic CE Power-Down Current – CMOS Inputs	Max V _{CC} , $\overline{CE} \geq V_{CC} - 0.3 V$, V _{IN} ≥ V _{CC} - 0.3 V, or V _{IN} ≤ 0.3 V, f = 0	-	3	mA	

Note

- V_{IL} (min) = -2.0 V and V_{IH} (max) = V_{CC} + 1 V for pulse durations of less than 5 ns.
- Please note that the maximum V_{OH} limit does not exceed minimum CMOS V_{IH} of 3.5V. If you are interfacing this SRAM with 5 V legacy processors that require a minimum V_{IH} of 3.5 V, please refer to Application Note [AN6081](#) for technical details and options you may consider.

Capacitance

Parameter ^[4]	Description	Test Conditions	Max	Unit
C _{IN}	Input capacitance	T _A = 25 °C, f = 1 MHz, V _{CC} = 5.0 V	6	pF
C _{OUT}	Output capacitance		8	pF

Thermal Resistance

Parameter ^[4]	Description	Test Conditions	400-Mil Wide SOJ	TSOP II	Unit
Θ _{JA}	Thermal resistance (junction to ambient)	Still Air, soldered on a 3 × 4.5 inch, four-layer printed circuit board	56.29	62.22	°C/W
Θ _{JC}	Thermal resistance (junction to case)		38.14	21.43	°C/W

AC Test Loads and Waveforms

Figure 2. AC Test Loads and Waveforms ^[5]

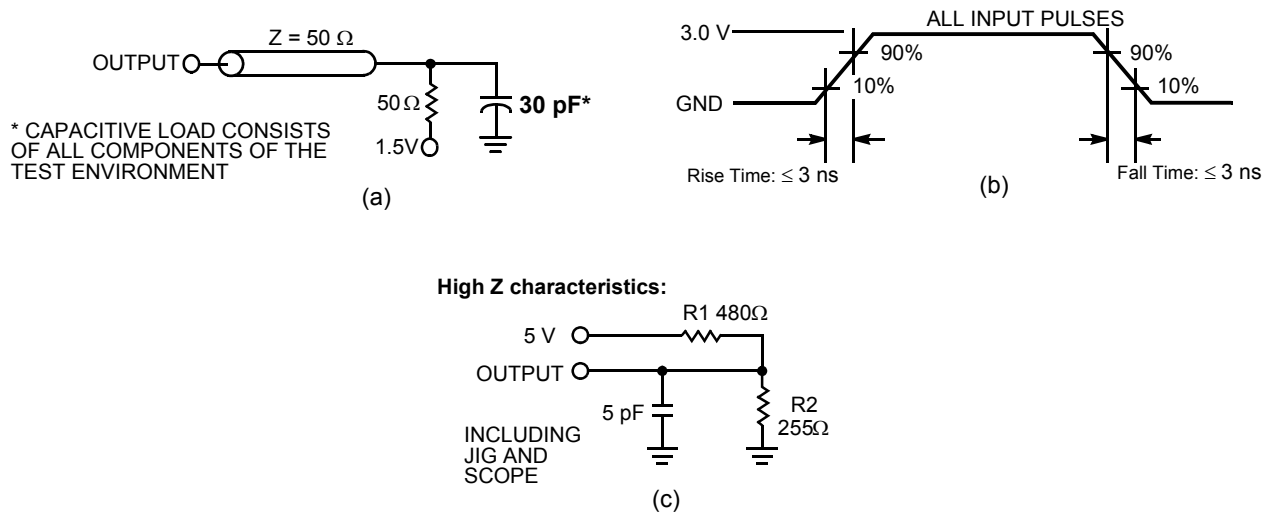

Notes

- 4. Tested initially and after any design or process changes that may affect these parameters.
- 5. AC characteristics (except High Z) are tested using the load conditions shown in Figure 2 (a). High Z characteristics are tested for all speeds using the test load shown in Figure 2 (c).

Data Retention Characteristics

Over the Operating Range

Parameter	Description	Conditions	Min	Max	Unit
V_{DR}	V_{CC} for Data Retention		2.0	–	V
I_{CCDR}	Data Retention Current	$V_{CC} = V_{DR} = 2.0\text{ V}$, $\overline{CE} \geq V_{CC} - 0.3\text{ V}$, $V_{IN} \geq V_{CC} - 0.3\text{ V}$ or $V_{IN} \leq 0.3\text{ V}$	–	3	mA
$t_{CDR}^{[6]}$	Chip Deselect to Data Retention Time		0	–	ns
$t_R^{[7]}$	Operation Recovery Time		t_{RC}	–	ns

Data Retention Waveform

Figure 3. Data Retention Waveform

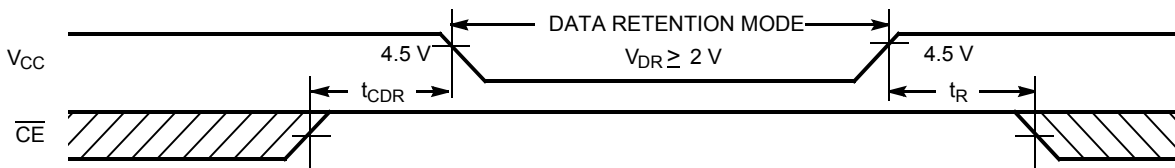

Notes

6. Tested initially and after any design or process changes that may affect these parameters.
7. Full device operation requires linear V_{CC} ramp from V_{DR} to $V_{CC(min)} \geq 50\ \mu\text{s}$ or stable at $V_{CC(min)} \geq 50\ \mu\text{s}$.

Switching Characteristics

Over the Operating Range

Parameter ^[8]	Description	-10 (Industrial)		Unit
		Min	Max	
Read Cycle				
$t_{\text{power}}^{[9]}$	V_{CC} (typical) to the first access	100	–	μs
t_{RC}	Read Cycle Time	10	–	ns
t_{AA}	Address to Data Valid	–	10	ns
t_{OHA}	Data Hold from Address Change	3	–	ns
t_{ACE}	$\overline{\text{CE}}$ LOW to Data Valid	–	10	ns
t_{DOE}	$\overline{\text{OE}}$ LOW to Data Valid	–	5	ns
t_{LZOE}	$\overline{\text{OE}}$ LOW to Low Z	0	–	ns
t_{HZOE}	$\overline{\text{OE}}$ HIGH to High Z ^[10, 11]	–	5	ns
t_{LZCE}	$\overline{\text{CE}}$ LOW to Low Z ^[11]	3	–	ns
t_{HZCE}	$\overline{\text{CE}}$ HIGH to High Z ^[10, 11]	–	5	ns
$t_{\text{PU}}^{[12]}$	$\overline{\text{CE}}$ LOW to Power-Up	0	–	ns
$t_{\text{PD}}^{[12]}$	$\overline{\text{CE}}$ HIGH to Power-Down	–	10	ns
Write Cycle ^[13, 14]				
t_{WC}	Write Cycle Time	10	–	ns
t_{SCE}	$\overline{\text{CE}}$ LOW to Write End	7	–	ns
t_{AW}	Address Set-Up to Write End	7	–	ns
t_{HA}	Address Hold from Write End	0	–	ns
t_{SA}	Address Set-Up to Write Start	0	–	ns
t_{PWE}	$\overline{\text{WE}}$ Pulse Width	7	–	ns
t_{SD}	Data Set-Up to Write End	6	–	ns
t_{HD}	Data Hold from Write End	0	–	ns
t_{LZWE}	$\overline{\text{WE}}$ HIGH to Low Z ^[11]	3	–	ns
t_{HZWE}	$\overline{\text{WE}}$ LOW to High Z ^[10, 11]	–	5	ns

Notes

8. Test conditions assume signal transition time of 3 ns or less, timing reference levels of 1.5 V, input pulse levels of 0 to 3.0 V, and output loading of the specified $I_{\text{OL}}/I_{\text{OH}}$ and 30-pF load capacitance.
9. t_{POWER} gives the minimum amount of time that the power supply should be at typical V_{CC} values until the first memory access can be performed.
10. t_{HZOE} , t_{HZCE} , and t_{HZWE} are specified with a load capacitance of 5 pF as in (c) of Figure 2 on page 5. Transition is measured when the outputs enter a high impedance state.
11. At any given temperature and voltage condition, t_{HZCE} is less than t_{LZCE} , t_{HZOE} is less than t_{LZOE} , and t_{HZWE} is less than t_{LZWE} for any given device.
12. This parameter is guaranteed by design and is not tested.
13. The internal write time of the memory is defined by the overlap of $\overline{\text{CE}}$ LOW and $\overline{\text{WE}}$ LOW. $\overline{\text{CE}}$ and $\overline{\text{WE}}$ must be LOW to initiate a write, and the transition of any of these signals can terminate the write. The input data set-up and hold timing should be referenced to the leading edge of the signal that terminates the write.
14. The minimum write cycle time for Write Cycle no. 3 ($\overline{\text{WE}}$ controlled, $\overline{\text{OE}}$ LOW) is the sum of t_{HZWE} and t_{SD} .

Switching Waveforms

Figure 4. Read Cycle No. 1 (Address Transition Controlled) [15, 16]

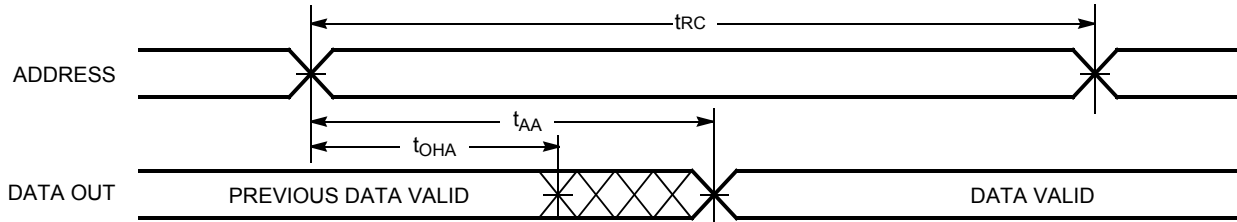
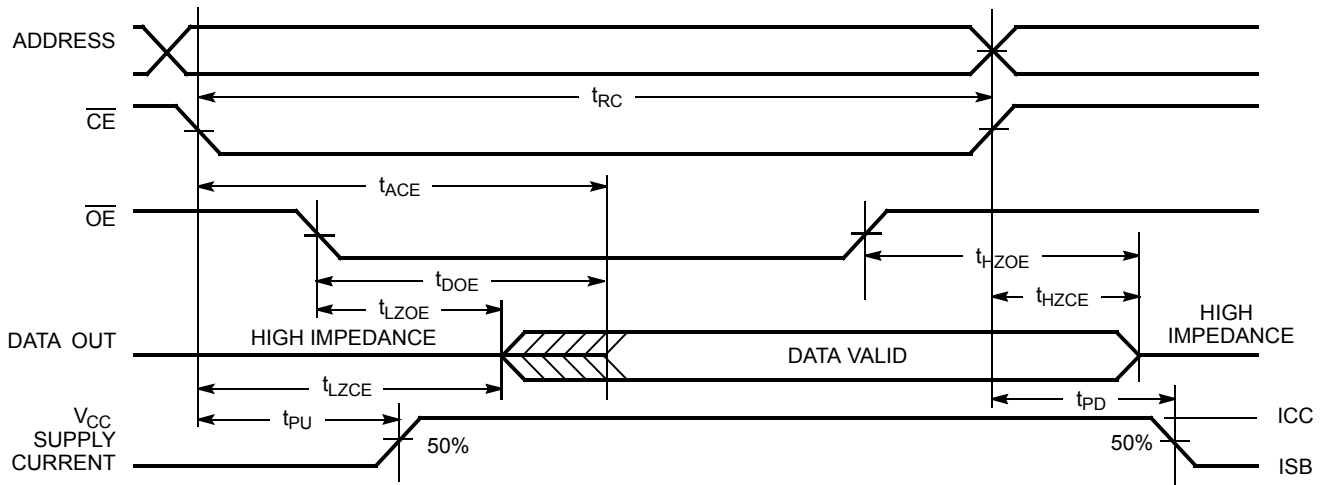

Figure 5. Read Cycle No. 2 (\overline{OE} Controlled) [16, 17]



Notes

- 15. Device is continuously selected. \overline{OE} , $\overline{CE} = V_{IL}$.
- 16. \overline{WE} is HIGH for Read cycle.
- 17. Address valid prior to or coincident with \overline{CE} transition LOW..

Switching Waveforms (continued)

Figure 6. Write Cycle No. 1 (\overline{CE} Controlled) [18, 19]

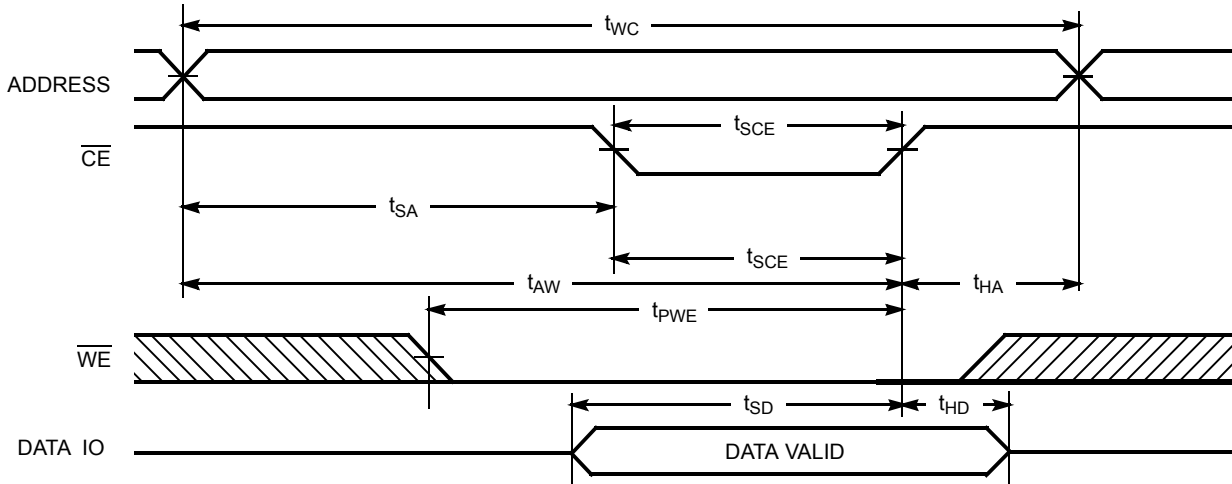
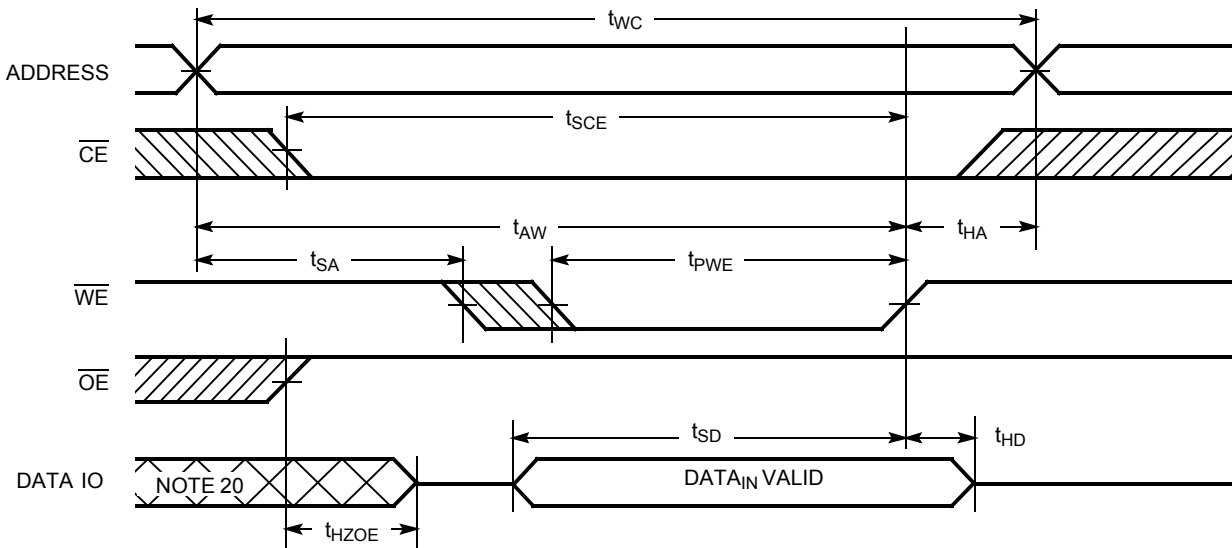

Figure 7. Write Cycle No. 2 (\overline{WE} Controlled, \overline{OE} HIGH During Write) [18, 19]



Notes

- 18. Data IO is high impedance if $\overline{OE} = V_{IH}$.
- 19. If CE goes HIGH simultaneously with WE going HIGH, the output remains in a high-impedance state.
- 20. During this period the IOs are in the output state and input signals should not be applied.

Switching Waveforms (continued)

Figure 8. Write Cycle No. 3 (\overline{WE} Controlled, \overline{OE} LOW) [21, 22]

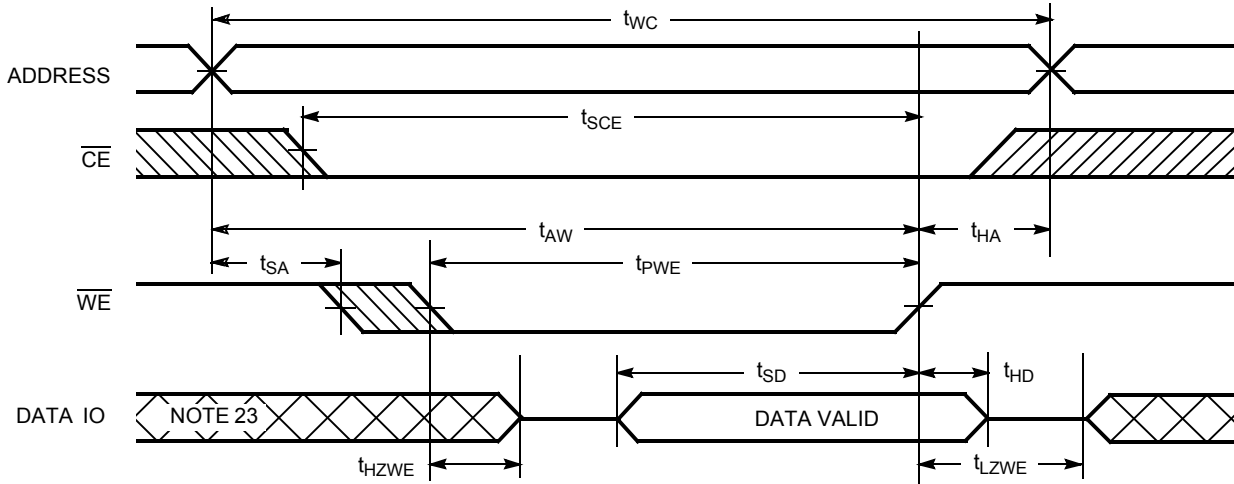

Notes

21. The minimum write cycle time for Write Cycle no. 3 (\overline{WE} controlled, \overline{OE} LOW) is the sum of t_{HZWE} and t_{SD} .

22. If \overline{CE} goes HIGH simultaneously with \overline{WE} going HIGH, the output remains in a high-impedance state.

23. During this period the IOs are in the output state and input signals should not be applied.

Truth Table

\overline{CE}	\overline{OE}	\overline{WE}	IO ₀ -IO ₇	Mode	Power
H	X	X	High Z	Power-Down	Standby (I _{SB})
L	L	H	Data Out	Read	Active (I _{CC})
L	X	L	Data In	Write	Active (I _{CC})
L	H	H	High Z	Selected, Outputs Disabled	Active (I _{CC})

Ordering Information

Speed (ns)	Ordering Code	Package Diagram	Package Type	Operating Range
10	CY7C1019D-10VXI	51-85033	32-pin SOJ (400 Mils) Pb-free	Industrial
	CY7C1019D-10ZSXI	51-85095	32-pin TSOP (Type II) Pb-free	

Please contact your local Cypress sales representative for availability of these parts.

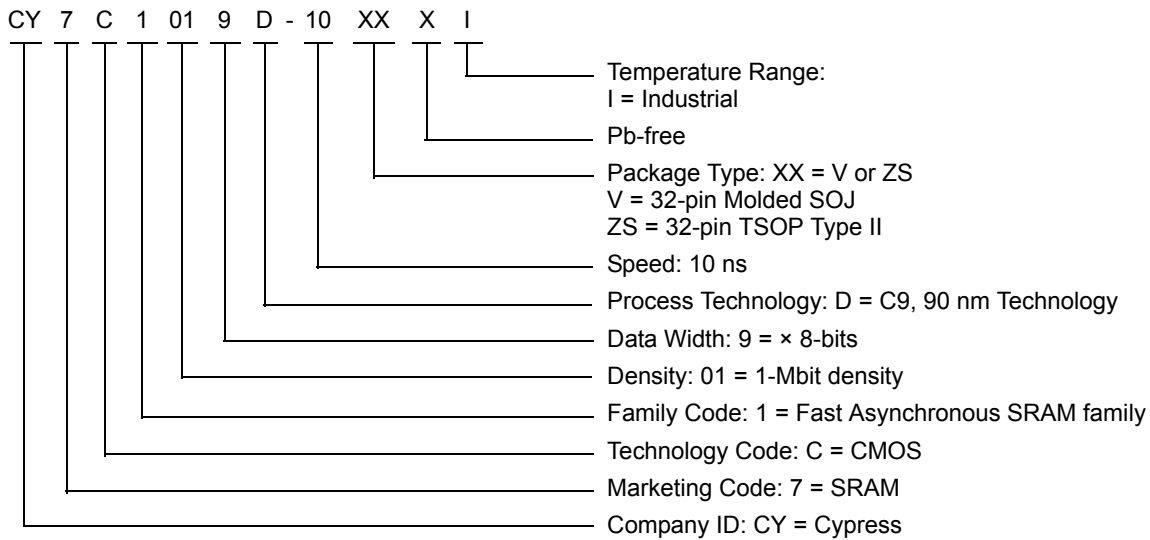
Ordering Code Definitions

Package Diagrams (continued)

Figure 10. 32-pin TSOP Type II (20.95 × 11.76 × 1.0 mm) ZS32 Package Outline, 51-85095

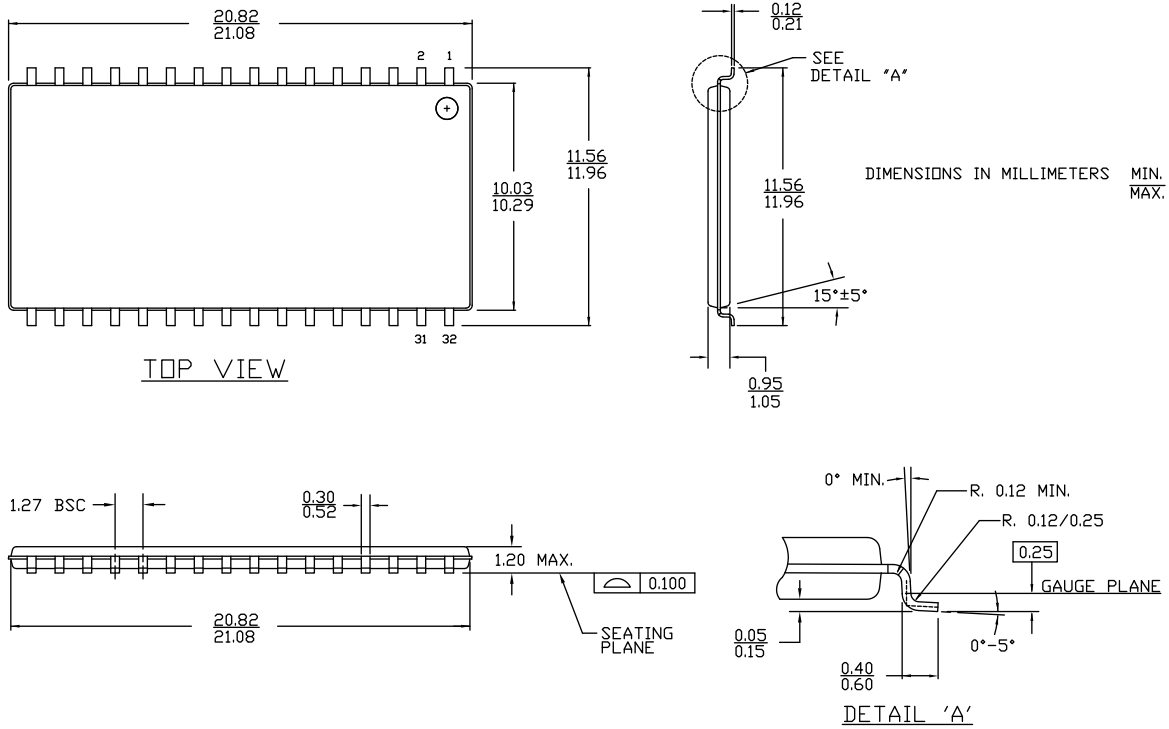

51-85095 *B

Acronyms

Acronym	Description
\overline{CE}	Chip Enable
CMOS	Complementary Metal Oxide Semiconductor
I/O	Input/Output
\overline{OE}	Output Enable
SOJ	Small Outline J-lead
SRAM	Static Random Access Memory
TSOP	Thin Small Outline Package
TTL	Transistor-Transistor Logic
\overline{WE}	Write Enable

Document Conventions

Units of Measure

Symbol	Unit of Measure
°C	degree Celsius
MHz	megahertz
μA	microampere
μs	microsecond
mA	milliampere
ms	millisecond
mm	millimeter
ns	nanosecond
Ω	ohm
%	percent
pF	picofarad
V	volt
W	watt

Document History Page

Document Title: CY7C1019D, 1-Mbit (128 K × 8) Static RAM Document Number: 38-05464				
Rev.	ECN No.	Issue Date	Orig. of Change	Description of Change
**	201560	See ECN	SWI	Advance Information data sheet for C9 IPP
*A	233715	See ECN	RKF	DC parameters are modified as per EROS (Spec # 01-2165) Pb-free offering in the Ordering Information
*B	262950	See ECN	RKF	Added T _{power} Spec in Switching Characteristics table Added Data Retention Characteristics table and waveforms Shaded Ordering Information
*C	307598	See ECN	RKF	Reduced Speed bins to -10 and -12 ns
*D	520647	See ECN	VKN	Converted from Preliminary to Final Removed Commercial Operating range Removed 12 ns speed bin Added I _{CC} values for the frequencies 83MHz, 66MHz and 40MHz Updated Thermal Resistance table Updated Ordering Information Table Changed Overshoot spec from V _{CC} +2V to V _{CC} +1V in footnote #2
*E	802877	See ECN	VKN	Changed I _{CC} spec from 60 mA to 80 mA for 100MHz, 55 mA to 72 mA for 83MHz, 45 mA to 58 mA for 66MHz, 30 mA to 37 mA for 40MHz
*F	3110052	12/14/2010	AJU	Added Ordering Code Definitions . Updated Package Diagrams .
*G	3245896	05/02/2011	PRAS	Updated Package Diagrams . Added Acronyms and Units of Measure . Updated in new template.
*H	4038234	06/24/2013	MEMJ	Updated Functional Description . Updated Electrical Characteristics : Added one more Test Condition "I _{OH} = -0.1 mA" for V _{OH} parameter and added maximum value corresponding to that Test Condition. Added Note 3 and referred the same note in maximum value for V _{OH} parameter corresponding to Test Condition "I _{OH} = -0.1 mA". Updated in new template.
*I	4385827	05/21/2014	MEMJ	Updated Package Diagrams : spec 51-85033 – Changed revision from *D to *E. Completing Sunset Review.
*J	4579569	11/26/2014	MEMJ	Added related documentation hyperlink in page 1.

Sales, Solutions, and Legal Information

Worldwide Sales and Design Support

Cypress maintains a worldwide network of offices, solution centers, manufacturer's representatives, and distributors. To find the office closest to you, visit us at cypress.com/sales.

Products

Automotive	cypress.com/go/automotive
Clocks & Buffers	cypress.com/go/clocks
Interface	cypress.com/go/interface
Lighting & Power Control	cypress.com/go/powerpsoc cypress.com/go/plc
Memory	cypress.com/go/memory
PSoC	cypress.com/go/psoc
Touch Sensing	cypress.com/go/touch
USB Controllers	cypress.com/go/USB
Wireless/RF	cypress.com/go/wireless

PSoC[®] Solutions

psoc.cypress.com/solutions
PSoC 1 | PSoC 3 | PSoC 4 | PSoC 5LP

Cypress Developer Community

[Community](#) | [Forums](#) | [Blogs](#) | [Video](#) | [Training](#)

Technical Support

cypress.com/go/support

© Cypress Semiconductor Corporation, 2004-2014. The information contained herein is subject to change without notice. Cypress Semiconductor Corporation assumes no responsibility for the use of any circuitry other than circuitry embodied in a Cypress product. Nor does it convey or imply any license under patent or other rights. Cypress products are not warranted nor intended to be used for medical, life support, life saving, critical control or safety applications, unless pursuant to an express written agreement with Cypress. Furthermore, Cypress does not authorize its products for use as critical components in life-support systems where a malfunction or failure may reasonably be expected to result in significant injury to the user. The inclusion of Cypress products in life-support systems application implies that the manufacturer assumes all risk of such use and in doing so indemnifies Cypress against all charges.



Any Source Code (software and/or firmware) is owned by Cypress Semiconductor Corporation (Cypress) and is protected by and subject to worldwide patent protection (United States and foreign), United States copyright laws and international treaty provisions. Cypress hereby grants to licensee a personal, non-exclusive, non-transferable license to copy, use, modify, create derivative works of, and compile the Cypress Source Code and derivative works for the sole purpose of creating custom software and or firmware in support of licensee product to be used only in conjunction with a Cypress integrated circuit as specified in the applicable agreement. Any reproduction, modification, translation, compilation, or representation of this Source Code except as specified above is prohibited without the express written permission of Cypress.

Disclaimer: CYPRESS MAKES NO WARRANTY OF ANY KIND, EXPRESS OR IMPLIED, WITH REGARD TO THIS MATERIAL, INCLUDING, BUT NOT LIMITED TO, THE IMPLIED WARRANTIES OF MERCHANTABILITY AND FITNESS FOR A PARTICULAR PURPOSE. Cypress reserves the right to make changes without further notice to the materials described herein. Cypress does not assume any liability arising out of the application or use of any product or circuit described herein. Cypress does not authorize its products for use as critical components in life-support systems where a malfunction or failure may reasonably be expected to result in significant injury to the user. The inclusion of Cypress' product in a life-support systems application implies that the manufacturer assumes all risk of such use and in doing so indemnifies Cypress against all charges.

Use may be limited by and subject to the applicable Cypress software license agreement.

Looking for pricing, stock, or lifecycle information?

Click below to explore more details on WIN SOURCE:

-  [View CY7C1019D-10ZSXI on WIN SOURCE](#)
-  [Cypress Semiconductor Corp Information](#)

Optimize Your Supply Chain with WIN SOURCE Solutions

-  Global Sourcing Solution
-  Obsolete Management
-  Cost Control Management
-  Shortage Management
-  Alternative Solution
-  Excess Inventory Management