



**THE DATASHEET OF
NB6L11DR2G**



NB6L11

2.5 V/3.3 V Multilevel Input to Differential LVPECL/LVNECL 1:2 Clock or Data Fanout Buffer/Translator

The NB6L11 is an enhanced differential 1:2 clock or data fanout buffer/translator. The device has the same pinout and is functionally equivalent to the LVEL11, EP11, LVEP11 devices. Moreover, the device is optimized for the systems that require LOW skew, LOW jitter and LOW power consumption.

Differential input can be configured to accept single-ended signal by applying an external reference voltage to unused complementary input pin. Input accept LVNECL, LVPECL, LVTTTL, LVCMOS, CML, or LVDS. The outputs are 800 mV ECL signals.

Features

- Input Clock Frequency ≥ 6 GHz
- Input Data Rate ≥ 6 Gb/s
- Low 14 mA Typical Power Supply Current
- 150 ps Typical Propagation Delay
- 5 ps Typical Within Device Skew
- 75 ps Typical Rise/Fall Times
- PECL Mode Operating Range:
 $V_{CC} = 2.375$ V to 3.465 V with $V_{EE} = 0$ V
- NECL Mode Op rating Range:
 $V_{CC} = 0$ V with $V_{EE} = -2.375$ V to -3.465 V
- Open Input Default State
- Q Outputs Will Default LOW with Inputs Open or at V_{EE}
- LVDS, LVPECL, LVNECL, LCMOS, LVTTTL and CML Input Compatible
- These Devices are Pb-Free and are RoHS Compliant



ON Semiconductor®

<http://onsemi.com>

MARKING DIAGRAMS*

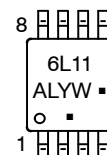
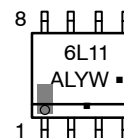

A = Assembly Location
L = Wafer Lot
Y = Year
W = Work Week
▪ = Pb-Free Package

(Note: Microdot may be in either location)

*For additional marking information, refer to Application Note AND8002/D.

ORDERING INFORMATION

See detailed ordering and shipping information in the package dimensions section on page 11 of this data sheet.

NB6L11

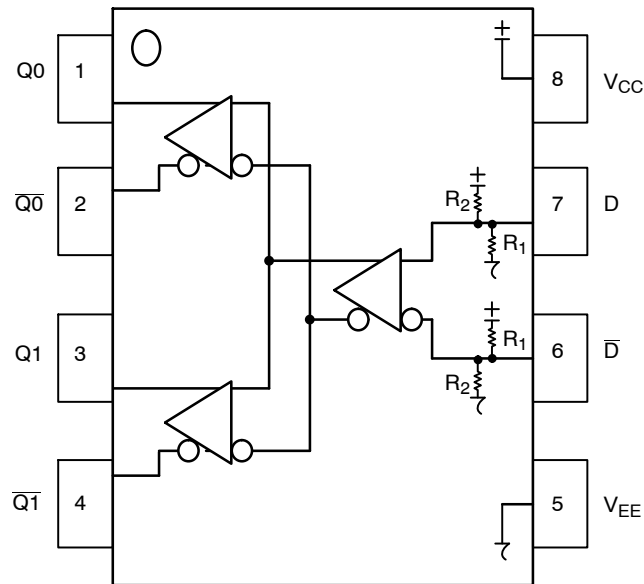

Figure 1. Pinout (Top View) and Logic Diagram

Table 1. PIN DESCRIPTION

Pin	Name	I/O	Default State	Description
1	Q0	ECL Output	-	Non-inverted differential clock/data output 0. Typically terminated with 50 Ω Resistor to $V_{TT} = V_{CC} - 2 V$.
2	$\overline{Q0}$	ECL Output	-	Inverted differential clock/data output 0. Typically terminated with 50 Ω resistor to $V_{TT} = V_{CC} - 2 V$.
3	Q1	ECL Output	-	Non-inverted differential clock/data output 1. Typically terminated with 50 Ω resistor to $V_{TT} = V_{CC} - 2 V$.
4	$\overline{Q1}$	ECL Output	-	Inverted differential clock/data output 1. Typically terminated with 50 Ω resistor to $V_{TT} = V_{CC} - 2 V$.
5	V_{EE}	-	-	Negative power supply voltage
6	\overline{D}	LVDS, CML, LVPECL, LVNECL, LVCMOS, LVTTTL Input	HIGH	Inverted differential clock/data input. Internal 37.5 k Ω to V_{CC} and 75 k Ω to V_{EE} .
7	D	LVDS, CML, LVPECL, LVNECL, LVCMOS, LVTTTL Input	LOW	Non-inverted differential clock/data input. Internal 75 k Ω to V_{CC} and 37.5 k Ω to V_{EE} .
8	V_{CC}	-	-	Positive power supply voltage

Table 2. ATTRIBUTES

Characteristics	Value	
Internal Input Resistor R1	37.5 k Ω	
Internal Input Resistor R2	75 k Ω	
ESD Protection	Human Body Model	> 2 kV
	Machine Model	> 100 V
	Charged Device Model	> 1 kV
Moisture Sensitivity, Indefinite Time Out of Drypack (Note 1)	Pb Pkg	Pb-Free Pkg
	SOIC-8	Level 1
	TSSOP-8	Level 1
		Level 3
Flammability Rating	Oxygen Index: 28 to 34	UL 94 V-0 @ 0.125 in
Transistor Count	167 Devices	
Meets or exceeds JEDEC Spec EIA/JESD78 IC Latchup Test		

1. For additional information, see Application Note AND8003/D.

NB6L11

Table 3. MAXIMUM RATINGS

Symbol	Parameter	Condition 1	Condition 2	Rating	Unit
V_{CC}	Positive Power Supply	$V_{EE} = 0\text{ V}$		3.6	V
V_{EE}	Negative Power Supply	$V_{CC} = 0\text{ V}$		-3.6	V
V_I	Positive Input Voltage Negative Input Voltage	$V_{EE} = 0\text{ V}$ $V_{CC} = 0\text{ V}$	$V_I \leq V_{CC}$ $V_I \geq V_{EE}$	3.6 -3.6	V V
V_{INPP}	Differential Input Voltage $ D - \bar{D} $	$V_{CC} - V_{EE} \geq 2.8\text{ V}$ $V_{CC} - V_{EE} < 2.8\text{ V}$		2.8 $ V_{CC} - V_{EE} $	V
I_{out}	Output Current	Continuous Surge		25 50	mA mA
T_A	Operating Temperature Range			-40 to +85	°C
T_{stg}	Storage Temperature Range			-65 to +150	°C
θ_{JA}	Thermal Resistance (Junction-to-Ambient)	0 lfpm 500 lfpm	SOIC-8 SOIC-8	190 130	°C/W °C/W
θ_{JC}	Thermal Resistance (Junction-to-Case)	Standard Board	SOIC-8	41 to 44	°C/W
θ_{JA}	Thermal Resistance (Junction-to-Ambient)	0 lfpm 500 lfpm	TSSOP-8 TSSOP-8	185 140	°C/W °C/W
θ_{JC}	Thermal Resistance (Junction-to-Case)	Standard Board	TSSOP-8	41 to 44	°C/W
T_{sol}	Wave Solder	Standard Pb-Free	$\leq 3\text{ sec @ }248^\circ\text{C}$ $\leq 3\text{ sec @ }260^\circ\text{C}$	265 265	°C

Stresses exceeding Maximum Ratings may damage the device. Maximum Ratings are stress ratings only. Functional operation above the Recommended Operating Conditions is not implied. Extended exposure to stresses above the Recommended Operating Conditions may affect device reliability.

NB6L11

Table 4. DC CHARACTERISTICS, PECL $V_{CC} = 2.5\text{ V}$, $V_{EE} = 0\text{ V}$ (Note 4)

Symbol	Characteristic	-40°C			25°C			85°C			Unit
		Min	Typ	Max	Min	Typ	Max	Min	Typ	Max	
I_{EE}	Negative Power Supply Current (Note 5)	5	14	20	5	14	20	5	14	20	mA
V_{OH}	Output HIGH Voltage (Note 6)	1350	1450	1550	1400	1500	1600	1450	1550	1650	mV
V_{OL}	Output LOW Voltage (Note 6)	565	725	870	630	765	920	690	825	970	mV

DIFFERENTIAL INPUT DRIVEN SINGLE-ENDED (Figures 14, 16) (Note 7)

V_{th}	Input Threshold Reference Voltage Range (Note 2)	1125		$V_{CC} - 75$	1125		$V_{CC} - 75$	1125		$V_{CC} - 75$	mV
V_{IH}	Single-Ended Input HIGH Voltage	$V_{th} + 75$		V_{CC}	$V_{th} + 75$		V_{CC}	$V_{th} + 75$		V_{CC}	mV
V_{IL}	Single-Ended Input LOW Voltage	V_{EE}		$V_{th} - 75$	V_{EE}		$V_{th} - 75$	V_{EE}		$V_{th} - 75$	mV

DIFFERENTIAL INPUTS DRIVEN DIFFERENTIALLY (Figures 15, 17) (Note 8)

V_{IHD}	Differential Input HIGH Voltage	1200		V_{CC}	1200		V_{CC}	1200		V_{CC}	mV
V_{ILD}	Differential Input LOW Voltage	V_{EE}		$V_{CC} - 75$	V_{EE}		$V_{CC} - 75$	V_{EE}		$V_{CC} - 75$	mV
V_{CMR}	Input Common Mode Range (Differential Cross-Point Voltage) (Note 3)	950		$V_{CC} - 38$	950		$V_{CC} - 38$	950		$V_{CC} - 38$	mV
V_{ID}	Differential Input Voltage ($V_{IHD} - V_{ILD}$)	75		2500	75		2500	75		2500	mV
I_{IH}	Input HIGH Current	D	50	150		50	150		50	150	μA
		\bar{D}	10	150		10	150		10	150	
I_{IL}	Input LOW Current	D	-150	-5		-150	-5		-150	-5	μA
		\bar{D}	-150	-30		-150	-30		-150	-30	

NOTE: Device will meet the specifications after thermal equilibrium has been established when mounted in a test socket or printed circuit board with maintained transverse airflow greater than 500 lfm. Electrical parameters are guaranteed only over the declared operating temperature range. Functional operation of the device exceeding these conditions is not implied. Device specification limit values are applied individually under normal operating conditions and not valid simultaneously.

- V_{th} is applied to the complementary input when operating in single-ended mode.
- V_{CMR} minimum varies 1:1 with V_{EE} , V_{CMR} maximum varies 1:1 with V_{CC} .
- Input and output parameters vary 1:1 with V_{CC} . V_{EE} can vary +0.125 V to -1.3 V.
- All input and output pins left open.
- All loading with $50\ \Omega$ to $V_{CC} - 2.0\text{ V}$.
- V_{th} , V_{IH} , and V_{IL} parameters must be complied with simultaneously.
- V_{IHD} , V_{ILD} , V_{ID} and V_{CMR} parameters must be complied with simultaneously.

NB6L11

Table 5. DC CHARACTERISTICS, PECL $V_{CC} = 3.3\text{ V}$, $V_{EE} = 0\text{ V}$ (Note 11)

Symbol	Characteristic	-40°C			25°C			85°C			Unit
		Min	Typ	Max	Min	Typ	Max	Min	Typ	Max	
I_{EE}	Negative Power Supply Current (Note 12)	5	14	20	5	14	20	5	14	20	mA
V_{OH}	Output HIGH Voltage (Note 13)	2150	2250	2350	2200	2300	2400	2250	2350	2450	mV
V_{OL}	Output LOW Voltage (Note 13)	1365	1525	1670	1430	1565	1720	1490	1625	1770	mV

DIFFERENTIAL INPUT DRIVEN SINGLE-ENDED (Figures 14, 16) (Note 14)

V_{th}	Input Threshold Reference Voltage Range (Note 9)	1125		$V_{CC} - 75$	1125		$V_{CC} - 75$	1125		$V_{CC} - 75$	mV
V_{IH}	Single-Ended Input HIGH Voltage	$V_{th} + 75$		V_{CC}	$V_{th} + 75$		V_{CC}	$V_{th} + 75$		V_{CC}	mV
V_{IL}	Single-Ended Input LOW Voltage	V_{EE}		$V_{th} - 75$	V_{EE}		$V_{th} - 75$	V_{EE}		$V_{th} - 75$	mV

DIFFERENTIAL INPUTS DRIVEN DIFFERENTIALLY (Figures 15, 17) (Note 15)

V_{IHD}	Differential Input HIGH Voltage	1200		V_{CC}	1200		V_{CC}	1200		V_{CC}	mV
V_{ILD}	Differential Input LOW Voltage	V_{EE}		$V_{CC} - 75$	V_{EE}		$V_{CC} - 75$	V_{EE}		$V_{CC} - 75$	mV
V_{CMR}	Input Common Mode Range (Differential Cross-Point Voltage) (Note 10)	950		$V_{CC} - 38$	950		$V_{CC} - 38$	950		$V_{CC} - 38$	mV
V_{ID}	Differential Input Voltage ($V_{IHD} - V_{ILD}$)	75		2500	75		2500	75		2500	mV
I_{IH}	Input HIGH Current	D D	50 10	150 150		50 10	150 150		50 10	150 150	μA
I_{IL}	Input LOW Current	D D	-150 -30	-5 -30		-150 -30	-5 -30		-150 -30	-5 -30	μA

NOTE: Device will meet the specifications after thermal equilibrium has been established when mounted in a test socket or printed circuit board with maintained transverse airflow greater than 500 lfm. Electrical parameters are guaranteed only over the declared operating temperature range. Functional operation of the device exceeding these conditions is not implied. Device specification limit values are applied individually under normal operating conditions and not valid simultaneously.

9. V_{th} is applied to the complementary input when operating in single-ended mode.
10. V_{CMR} minimum varies 1:1 with V_{EE} , V_{CMR} maximum varies 1:1 with V_{CC} .
11. Input and output parameters vary 1:1 with V_{CC} . V_{EE} can vary +0.3 V to -2.2 V.
12. All input and output pins left open.
13. All loading with 50 Ω to $V_{CC} - 2.0\text{ V}$.
14. V_{th} , V_{IH} , and V_{IL} parameters must be complied with simultaneously.
15. V_{IHD} , V_{ILD} , V_{ID} and V_{CMR} parameters must be complied with simultaneously.

NB6L11

Table 6. DC CHARACTERISTICS, NECL $V_{CC} = 0\text{ V}$; $V_{EE} = -3.465\text{ V}$ to -2.375 V (Note 18)

Symbol	Characteristic	-40°C			25°C			85°C			Unit
		Min	Typ	Max	Min	Typ	Max	Min	Typ	Max	
I_{EE}	Negative Power Supply Current (Note 19)	5	14	20	5	14	20	5	14	20	mA
V_{OH}	Output HIGH Voltage (Note 20)	-1150	-1050	-950	-1100	-1000	-900	-1050	-950	-850	mV
V_{OL}	Output LOW Voltage (Note 20)	-1935	-1775	-1630	-1870	-1735	-1580	-1810	-1675	-1530	mV

DIFFERENTIAL INPUT DRIVEN SINGLE-ENDED (Figures 14, 16) (Note 21)

V_{th}	Input Threshold Reference Voltage Range (Note 16)	$V_{EE} + 1125$		$V_{CC} - 75$	$V_{EE} + 1125$		$V_{CC} - 75$	$V_{EE} + 1125$		$V_{CC} - 75$	mV
V_{IH}	Single-Ended Input HIGH Voltage	$V_{th} + 75$		V_{CC}	$V_{th} + 75$		V_{CC}	$V_{th} + 75$		V_{CC}	mV
V_{IL}	Single-Ended Input LOW Voltage	V_{EE}		$V_{th} - 75$	V_{EE}		$V_{th} - 75$	V_{EE}		$V_{th} - 75$	mV

DIFFERENTIAL INPUTS DRIVEN DIFFERENTIALLY (Figures 15, 17) (Note 22)

V_{IHD}	Differential Input HIGH Voltage	$V_{EE} + 1200$		V_{CC}	$V_{EE} + 1200$		V_{CC}	$V_{EE} + 1200$		V_{CC}	mV
V_{ILD}	Differential Input LOW Voltage	V_{EE}		$V_{CC} - 75$	V_{EE}		$V_{CC} - 75$	V_{EE}		$V_{CC} - 75$	mV
V_{CMR}	Input Common Mode Range (Differential Cross-Point Voltage) (Note 17)	$V_{EE} + 950$		$V_{CC} - 38$	$V_{EE} + 950$		$V_{CC} - 38$	$V_{EE} + 950$		$V_{CC} - 38$	mV
V_{ID}	Differential Input Voltage ($V_{IHD} - V_{ILD}$)	75		2500	75		2500	75		2500	mV
I_{IH}	Input HIGH Current	\overline{D}	50	150	\overline{D}	50	150	\overline{D}	50	150	μA
I_{IL}	Input LOW Current	\overline{D}	-150	-5	\overline{D}	-150	-5	\overline{D}	-150	-5	μA

NOTE: Device will meet the specifications after thermal equilibrium has been established when mounted in a test socket or printed circuit board with maintained transverse airflow greater than 500 lfpm. Electrical parameters are guaranteed only over the declared operating temperature range. Functional operation of the device exceeding these conditions is not implied. Device specification limit values are applied individually under normal operating conditions and not valid simultaneously.

16. V_{th} is applied to the complementary input when operating in single-ended mode.

17. V_{CMR} minimum varies 1:1 with V_{EE} , V_{CMR} maximum varies 1:1 with V_{CC} .

18. Input and output parameters vary 1:1 with V_{CC} .

19. Input and output pins left open.

20. All loading with $50\ \Omega$ to $V_{CC} - 2.0\text{ V}$.

21. V_{th} , V_{IH} , and V_{IL} parameters must be complied with simultaneously.

22. V_{IHD} , V_{ILD} , V_{ID} and V_{CMR} parameters must be complied with simultaneously.

NB6L11

Table 7. AC CHARACTERISTICS $V_{CC} = 0\text{ V}$; $V_{EE} = -3.465\text{ V}$ to -2.375 V or $V_{CC} = 2.375\text{ V}$ to 3.465 V ; $V_{EE} = 0\text{ V}$ (Note 23)

Symbol	Characteristic	-40°C			25°C			85°C			Unit
		Min	Typ	Max	Min	Typ	Max	Min	Typ	Max	
V_{OUTPP}	Output Voltage Amplitude (See Figures 2 & 3) $f_{in} \leq 3\text{ GHz}$ $f_{in} \leq 6\text{ GHz}$	480 270	700 300		480 270	700 300		480 270	700 300		mV
f_{DATA}	Maximum Operating Data Rate	6									Gb/s
t_{PLH} , t_{PHL}	Propagation Delay to Output Differential @ 1 GHz D to Q, \bar{Q}	110	150	190	110	150	200	120	160	220	ps
t_{SKEW}	Duty Cycle Skew Within Device Skew Device-to-Device Skew (Note 24)		2 5 15	10 15 60		2 5 15	10 15 60		2 5 15	10 15 60	ps
t_{JITTER}	RMS Random Clock Jitter (Note 25) Peak-to-Peak Data Dependent Jitter (Note 26) $f_{in} \leq 6\text{ GHz}$ $f_{in} \leq 6\text{ Gb/s}$		0.2 2	1 12		0.2 2	1 12		0.2 2	1 12	ps
V_{INPP}	Input Voltage Swing / Sensitivity (Differential Configuration) (Note 27)	75	700	2500	75	700	2500	75	700	2500	mV
t_r , t_f	Output Rise/Fall Times @ 1 GHz (20% - 80%) Q, \bar{Q}	30	75	120	30	75	120	30	75	120	ps

NOTE: Device will meet the specifications after thermal equilibrium has been established when mounted in a test socket or printed circuit board with maintained transverse airflow greater than 500 lfm. Electrical parameters are guaranteed only over the declared operating temperature range. Functional operation of the device exceeding these conditions is not implied. Device specification limit values are applied individually under normal operating conditions and not valid simultaneously.

23. Measured using a 800 mV source, 50% duty cycle clock source. All loading with $50\ \Omega$ to $V_{CC} - 2.0\text{ V}$. Input edge rates 40 ps (20% - 80%).

24. See Figure 13 $t_{skew} = |t_{PLH} - t_{PHL}|$ for a nominal 50% differential clock input waveform. Skew is measured between outputs under identical transitions and conditions @ 1 GHz.

25. Additive RMS jitter with 50% duty cycle clock signal at 6 GHz.

26. Additive Peak-to-Peak data dependent jitter with NRZ PRBS $2^{23}-1$ data rate at 6 Gb/s.

27. $V_{INPP(max)}$ cannot exceed $V_{CC} - V_{EE}$ (applicable only when $V_{CC} - V_{EE} < 2500\text{ mV}$). Input voltage swing is a single-ended measurement operating in differential mode

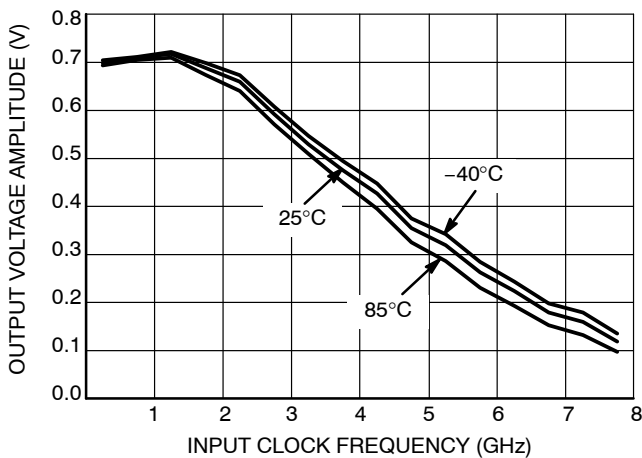

Figure 2. Output Voltage Amplitude (V_{OUTPP}) versus Input Clock Frequency (f_{IN}) and Temperature at $V_{CC} - V_{EE} = 3.3\text{ V}$

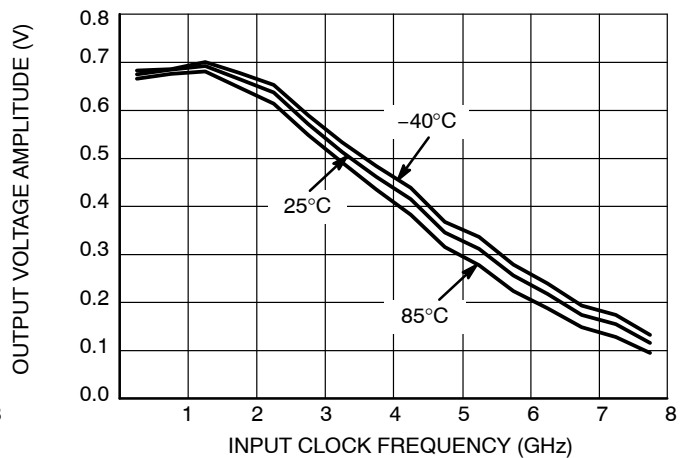

Figure 3. Output Voltage Amplitude (V_{OUTPP}) versus Input Clock Frequency (f_{IN}) and Temperature at $V_{CC} - V_{EE} = 2.5\text{ V}$

NB6L11

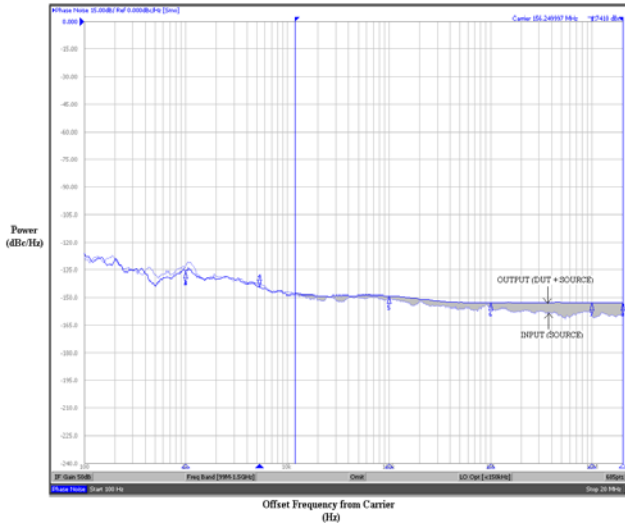

Figure 4. Typical Phase Noise Plot at $f_{\text{carrier}} = 156.25 \text{ MHz}$

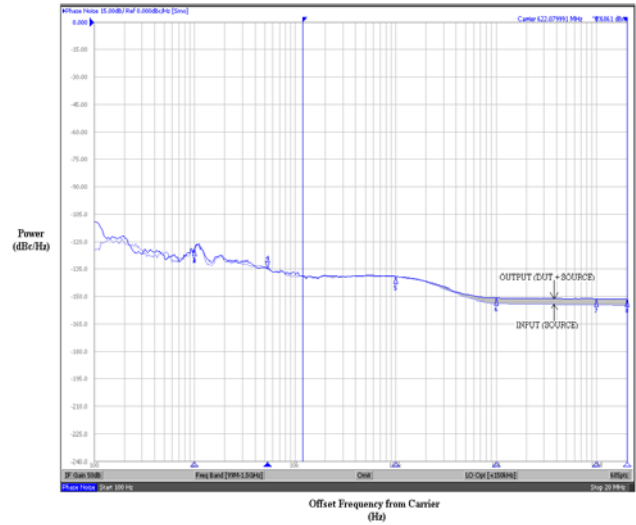

Figure 5. Typical Phase Noise Plot at $f_{\text{carrier}} = 622.08 \text{ MHz}$

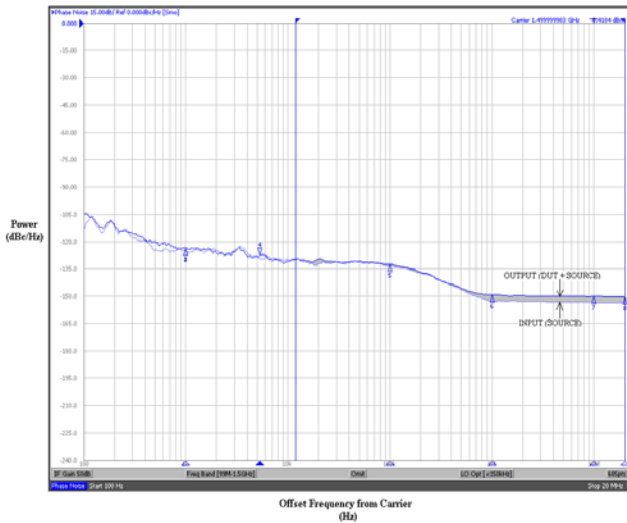

Figure 6. Typical Phase Noise Plot at $f_{\text{carrier}} = 1.5 \text{ GHz}$

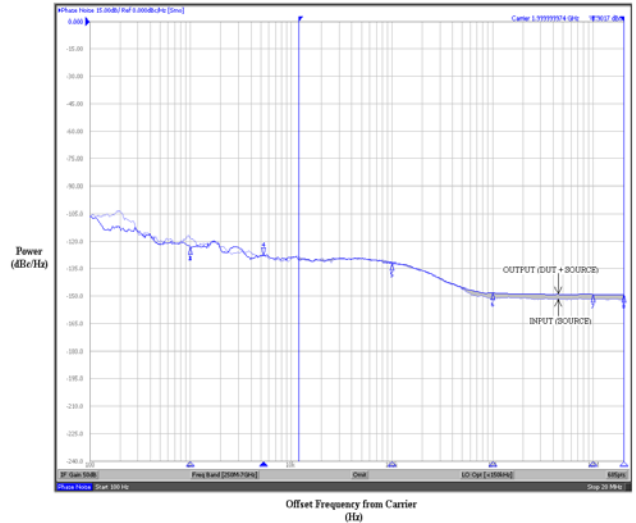

Figure 7. Typical Phase Noise Plot at $f_{\text{carrier}} = 2 \text{ GHz}$

The above phase noise plots captured using Agilent E5052A show additive phase noise of the NB6L11 device at frequencies 156.25 MHz, 622.08 MHz, 1.5 GHz and 2 GHz respectively at an operating voltage of 3.3 V in room temperature. The RMS Phase Jitter contributed by the

device (integrated between 12 kHz and 20 MHz; as shown in the shaded region of the plot) at each of the frequencies is 75 fs, 12 fs, 6 fs and 4 fs respectively. The input source used for the phase noise measurements is Agilent E8663B.

NB6L11

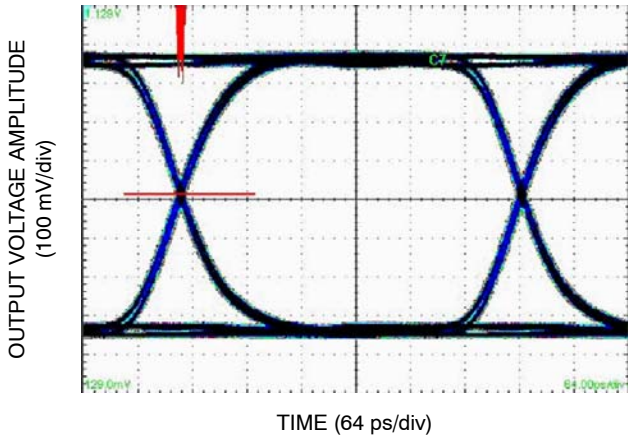

Figure 8. Typical Output Waveform at 2.488 Gb/s with PRBS 2²³-1 (Total System Pk-Pk Jitter is 17 ps. Device Pk-Pk Jitter Contribution is 4 ps)

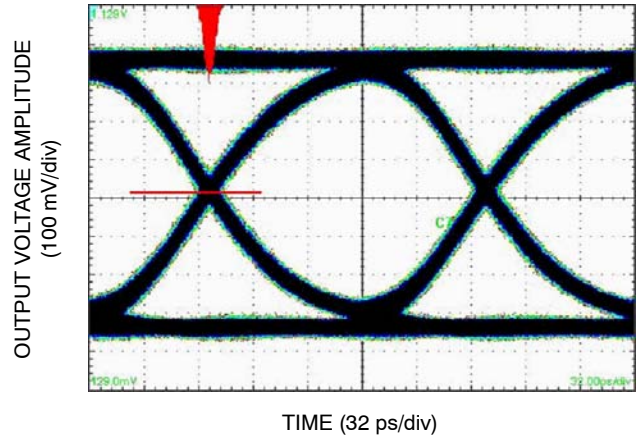

Figure 9. Typical Output Waveform at 6.125 Gb/s with PRBS 2²³-1 (Total System Pk-Pk Jitter is 20 ps. Device Pk-Pk Jitter Contribution is 5 ps)

NOTE: $V_{CC} - V_{EE} = 3.3 \text{ V}$; $V_{IN} = 700 \text{ mV}$; $T_A = 25^\circ\text{C}$.

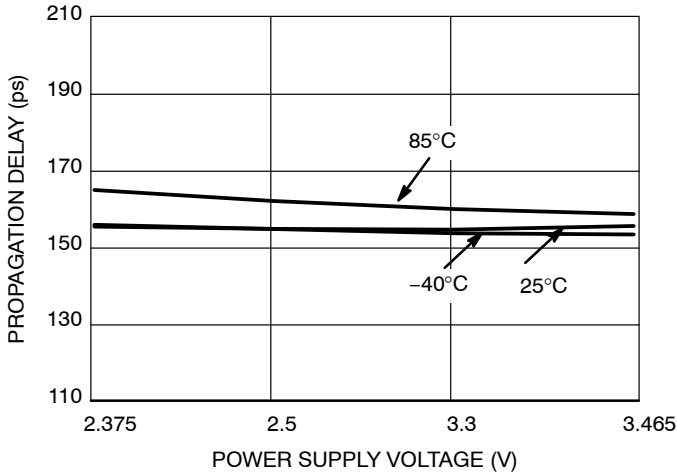

Figure 10. Propagation Delay versus Power Supply Voltage and Temperature

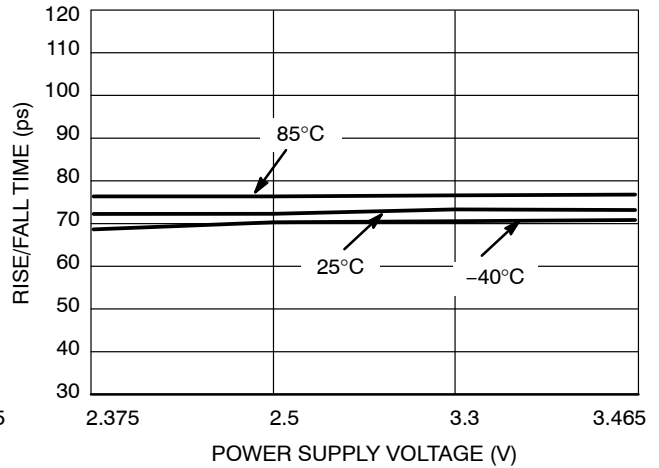

Figure 11. Rise/Fall Time versus Power Supply Voltage and Temperature

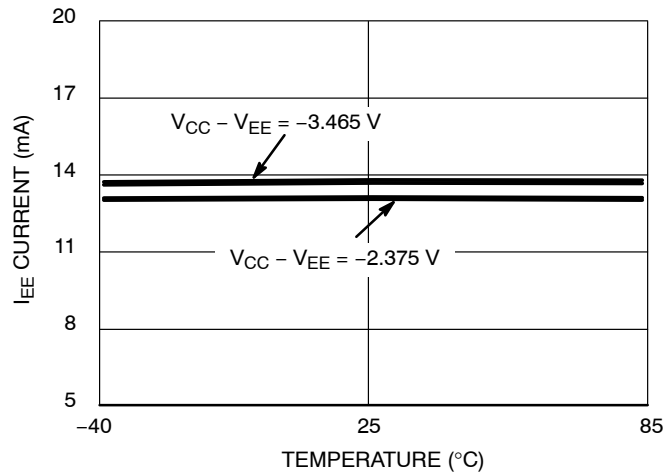

Figure 12. I_{EE} Current versus Temperature and Power Supply Voltage

NB6L11

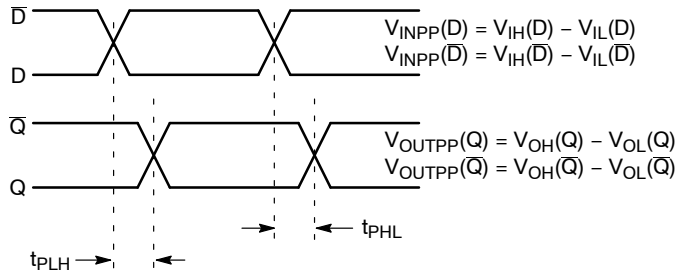

Figure 13. AC Reference Measurement

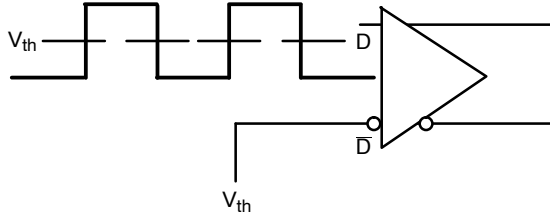

Figure 14. Differential Input Driven Single-Ended

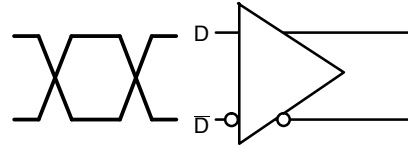

Figure 15. Differential Inputs Driven Differentially

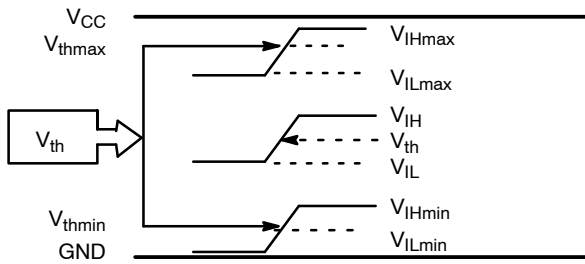

Figure 16. V_{th} Diagram

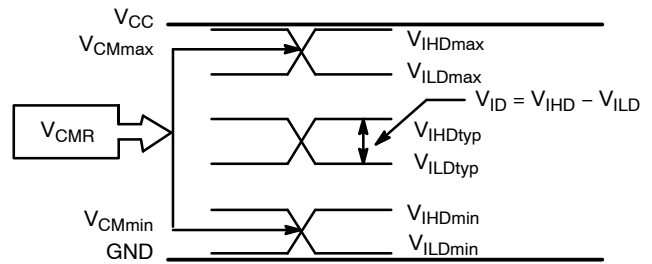

Figure 17. V_{CMR} Diagram

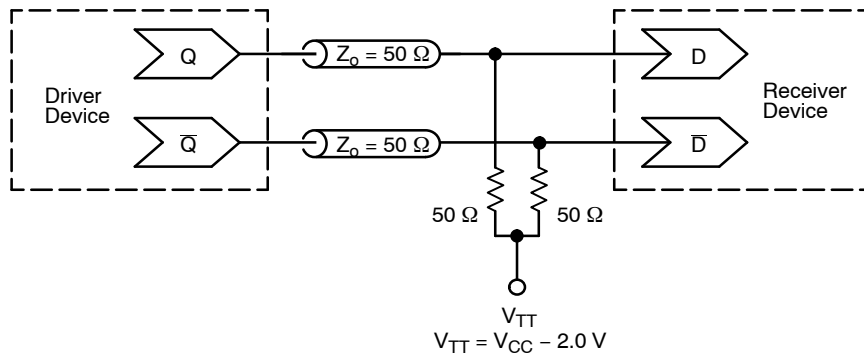

Figure 18. Typical Termination for Output Driver and Device Evaluation (See Application Note AND8020/D – Termination of ECL Logic Devices.)

NB6L11

ORDERING INFORMATION

Device	Package	Shipping†
NB6L11DG	SOIC-8 (Pb-Free)	98 Units / Rail
NB6L11DR2G	SOIC-8 (Pb-Free)	2500 / Tape & Reel
NB6L11DTG	TSSOP-8 (Pb-Free)	100 Units / Rail
NB6L11DTR2G	TSSOP-8 (Pb-Free)	2500 / Tape & Reel

†For information on tape and reel specifications, including part orientation and tape sizes, please refer to our Tape and Reel Packaging Specifications Brochure, BRD8011/D.

Resource Reference of Application Notes

- AN1405/D** - ECL Clock Distribution Techniques
- AN1406/D** - Designing with PECL (ECL at +5.0 V)
- AN1503/D** - ECLinPS™ I/O SPiCE Modeling Kit
- AN1504/D** - Metastability and the ECLinPS Family
- AN1568/D** - Interfacing Between LVDS and ECL
- AN1672/D** - The ECL Translator Guide
- AND8001/D** - Odd Number Counters Design
- AND8002/D** - Marking and Date Codes
- AND8020/D** - Termination of ECL Logic Devices
- AND8066/D** - Interfacing with ECLinPS
- AND8090/D** - AC Characteristics of ECL Devices

NB6L11

PACKAGE DIMENSIONS

SOIC-8 NB
D SUFFIX
CASE 751-07
ISSUE AK

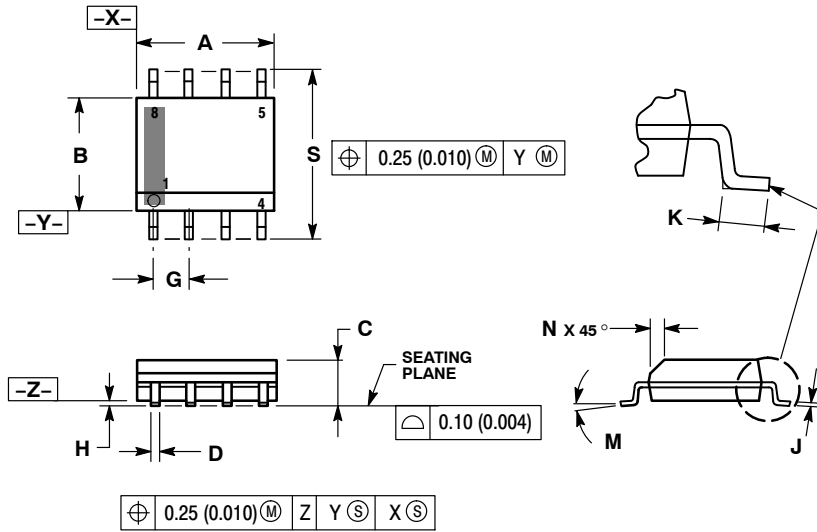

NOTES:

1. DIMENSIONING AND TOLERANCING PER ANSI Y14.5M, 1982.
2. CONTROLLING DIMENSION: MILLIMETER.
3. DIMENSION A AND B DO NOT INCLUDE MOLD PROTRUSION.
4. MAXIMUM MOLD PROTRUSION 0.15 (0.006) PER SIDE.
5. DIMENSION D DOES NOT INCLUDE DAMBAR PROTRUSION. ALLOWABLE DAMBAR PROTRUSION SHALL BE 0.127 (0.005) TOTAL IN EXCESS OF THE D DIMENSION AT MAXIMUM MATERIAL CONDITION.
6. 751-01 THRU 751-06 ARE OBSOLETE. NEW STANDARD IS 751-07.

DIM	MILLIMETERS		INCHES	
	MIN	MAX	MIN	MAX
A	4.80	5.00	0.189	0.197
B	3.80	4.00	0.150	0.157
C	1.35	1.75	0.053	0.069
D	0.33	0.51	0.013	0.020
G	1.27 BSC		0.050 BSC	
H	0.10	0.25	0.004	0.010
J	0.19	0.25	0.007	0.010
K	0.40	1.27	0.016	0.050
M	0°	8°	0°	8°
N	0.25	0.50	0.010	0.020
S	5.80	6.20	0.228	0.244

SOLDERING FOOTPRINT*

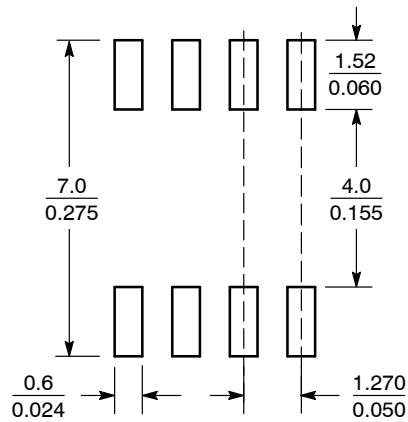

SCALE 6:1 $\left(\frac{\text{mm}}{\text{inches}}\right)$

*For additional information on our Pb-Free strategy and soldering details, please download the ON Semiconductor Soldering and Mounting Techniques Reference Manual, SOLDERRM/D.

NB6L11

PACKAGE DIMENSIONS

TSSOP-8
DT SUFFIX
CASE 948R-02
ISSUE A

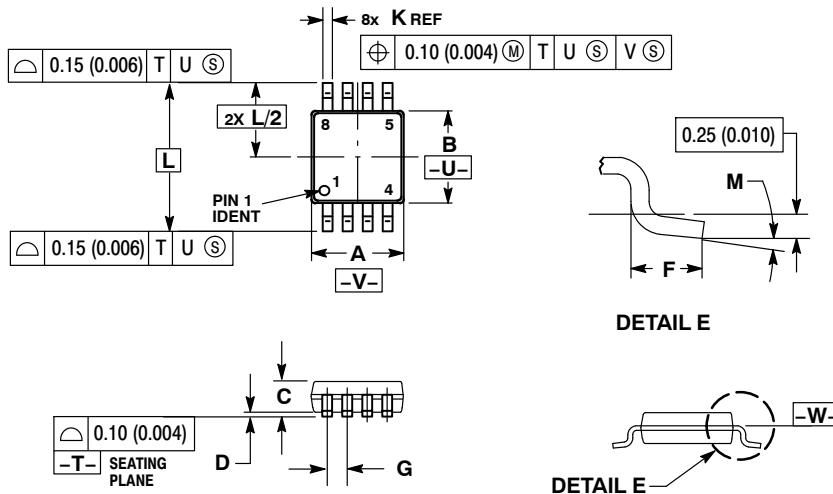

NOTES:

1. DIMENSIONING AND TOLERANCING PER ANSI Y14.5M, 1982.
2. CONTROLLING DIMENSION: MILLIMETER.
3. DIMENSION A DOES NOT INCLUDE MOLD FLASH. PROTRUSIONS OR GATE BURRS. MOLD FLASH OR GATE BURRS SHALL NOT EXCEED 0.15 (0.006) PER SIDE.
4. DIMENSION B DOES NOT INCLUDE INTERLEAD FLASH OR PROTRUSION. INTERLEAD FLASH OR PROTRUSION SHALL NOT EXCEED 0.25 (0.010) PER SIDE.
5. TERMINAL NUMBERS ARE SHOWN FOR REFERENCE ONLY.
6. DIMENSION A AND B ARE TO BE DETERMINED AT DATUM PLANE -W-.

DIM	MILLIMETERS		INCHES	
	MIN	MAX	MIN	MAX
A	2.90	3.10	0.114	0.122
B	2.90	3.10	0.114	0.122
C	0.80	1.10	0.031	0.043
D	0.05	0.15	0.002	0.006
F	0.40	0.70	0.016	0.028
G	0.65 BSC		0.026 BSC	
K	0.25	0.40	0.010	0.016
L	4.90 BSC		0.193 BSC	
M	0°	6°	0°	6°

ECLinPS is a trademark of Semiconductor Components Industries, LLC.

ON Semiconductor and **ON** are registered trademarks of Semiconductor Components Industries, LLC (SCILLC). SCILLC owns the rights to a number of patents, trademarks, copyrights, trade secrets, and other intellectual property. A listing of SCILLC's product/patent coverage may be accessed at www.onsemi.com/site/pdf/Patent-Marking.pdf. SCILLC reserves the right to make changes without further notice to any products herein. SCILLC makes no warranty, representation or guarantee regarding the suitability of its products for any particular purpose, nor does SCILLC assume any liability arising out of the application or use of any product or circuit, and specifically disclaims any and all liability, including without limitation special, consequential or incidental damages. "Typical" parameters which may be provided in SCILLC data sheets and/or specifications can and do vary in different applications and actual performance may vary over time. All operating parameters, including "Typicals" must be validated for each customer application by customer's technical experts. SCILLC does not convey any license under its patent rights nor the rights of others. SCILLC products are not designed, intended, or authorized for use as components in systems intended for surgical implant into the body, or other applications intended to support or sustain life, or for any other application in which the failure of the SCILLC product could create a situation where personal injury or death may occur. Should Buyer purchase or use SCILLC products for any such unintended or unauthorized application, Buyer shall indemnify and hold SCILLC and its officers, employees, subsidiaries, affiliates, and distributors harmless against all claims, costs, damages, and expenses, and reasonable attorney fees arising out of, directly or indirectly, any claim of personal injury or death associated with such unintended or unauthorized use, even if such claim alleges that SCILLC was negligent regarding the design or manufacture of the part. SCILLC is an Equal Opportunity/Affirmative Action Employer. This literature is subject to all applicable copyright laws and is not for resale in any manner.

PUBLICATION ORDERING INFORMATION

LITERATURE FULFILLMENT:
Literature Distribution Center for ON Semiconductor
P.O. Box 5163, Denver, Colorado 80217 USA
Phone: 303-675-2175 or 800-344-3860 Toll Free USA/Canada
Fax: 303-675-2176 or 800-344-3867 Toll Free USA/Canada
Email: orderlit@onsemi.com

N. American Technical Support: 800-282-9855 Toll Free
USA/Canada
Europe, Middle East and Africa Technical Support:
Phone: 421 33 790 2910
Japan Customer Focus Center
Phone: 81-3-5817-1050

ON Semiconductor Website: www.onsemi.com
Order Literature: <http://www.onsemi.com/orderlit>
For additional information, please contact your local Sales Representative

Looking for pricing, stock, or lifecycle information?

Click below to explore more details on WIN SOURCE:

 [View NB6L11DR2G on WIN SOURCE](#)

 [ON Semiconductor](#) Information

Optimize Your Supply Chain with WIN SOURCE Solutions

-  Global Sourcing Solution
-  Obsolete Management
-  Cost Control Management
-  Shortage Management
-  Alternative Solution
-  Excess Inventory Management