



**THE DATASHEET OF
SN10KHT5574NT**



SN10KHT5574

OCTAL ECL-TO-TTL TRANSLATOR WITH D-TYPE EDGE-TRIGGERED FLIP-FLOPS AND 3-STATE OUTPUTS

SDZS010 – JANUARY 1990 – REVISED OCTOBER 1990

- 10KH Compatible
- ECL Clock and TTL Control Inputs
- Flow-Through Architecture Optimizes PCB Layout
- Center Pin V_{CC} , V_{EE} , and GND Configurations Minimize High-Speed Switching Noise
- Package Options Include “Small Outline” Packages and Standard Plastic DIPs

DW OR NT PACKAGE
(TOP VIEW)

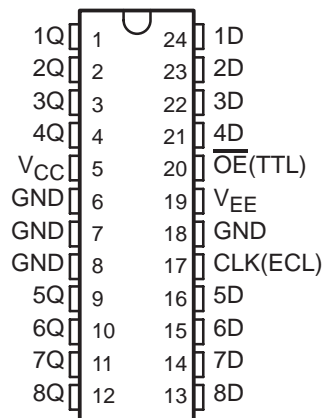

description

This octal ECL-to-TTL translator is designed to provide efficient translation between a 10KH ECL signal environment and a TTL signal environment.

This device is designed specifically to improve the performance and density of ECL-to-TTL CPU/bus-oriented functions such as memory-address drivers, clock drivers, and bus-oriented receivers and transmitters.

The eight flip-flops of the SN10KHT5574 are edge-triggered D-type flip-flops. On the positive transition of the clock, the Q outputs are set to the logic levels that were set up at the D inputs.

A buffered output-enable input (\overline{OE}) can be used to place the eight outputs in either a normal logic state (high or low logic levels) or a high-impedance state. In the high-impedance state, the outputs neither load nor drive the bus lines significantly. The high-impedance third state and increased drive provide the capability to drive bus lines without need for interface or pullup components.

The output-enable input \overline{OE} does not affect the internal operations of the flip-flops. Old data can be retained or new data can be entered while the outputs are off.

The SN10KHT5574 is characterized for operation from 0°C to 75°C.

FUNCTION TABLE

| INPUTS | | | OUTPUT (TTL) |
|-----------------|-----|---|-----------------|
| \overline{OE} | CLK | D | Q |
| L | ↑ | L | L |
| L | ↑ | H | H |
| L | L | X | Q_0 |
| H | X | X | Z |

SN10KHT5574

OCTAL ECL-TO-TTL TRANSLATOR WITH D-TYPE EDGE-TRIGGERED FLIP-FLOPS AND 3-STATE OUTPUTS

SDZS010 – JANUARY 1990 – REVISED OCTOBER 1990

logic symbol†

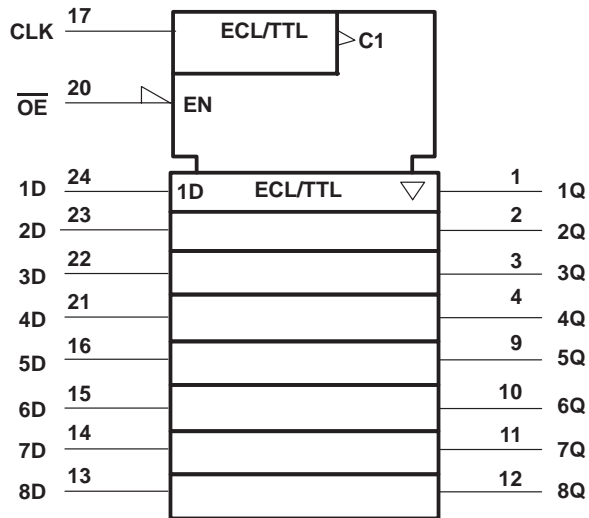

† This symbol is in accordance with ANSI/IEEE Std 91-1984 and IEC Publication 617-12.

logic diagram (positive logic)

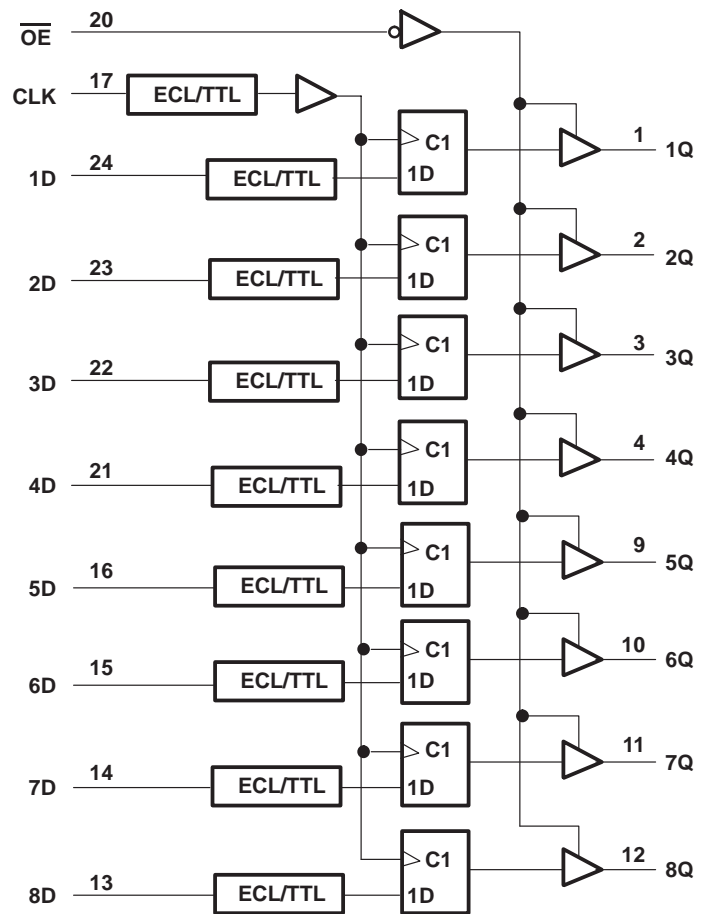

SN10KHT5574

OCTAL ECL-TO-TTL TRANSLATOR WITH D-TYPE EDGE-TRIGGERED FLIP-FLOPS AND 3-STATE OUTPUTS

SDZS010 – JANUARY 1990 – REVISED OCTOBER 1990

absolute maximum ratings over operating temperature range (unless otherwise noted)†

| | |
|--|--------------------|
| Supply voltage range, V_{CC} | –0.5 V to 7 V |
| Supply voltage range, V_{EE} | –8 V to 0 V |
| Input voltage range: TTL (see Note 1) | –1.2 V to 7 V |
| ECL | V_{EE} to 0 V |
| Voltage applied to any output in the disabled or power-off state | –0.5 V to 5.5 V |
| Voltage applied to any output in the high state | –0.5 V to V_{CC} |
| Input current range, (TTL) | –30 mA to 5 mA |
| Current into any output in the low state | 96 mA |
| Operating free-air temperature range | 0°C to 75°C |
| Storage temperature range | –65°C to 150°C |

† Stresses beyond those listed under “absolute maximum ratings” may cause permanent damage to the device. These are stress ratings only, and functional operation of the device at these or any other conditions beyond those indicated under “recommended operating conditions” is not implied. Exposure to absolute-maximum-rated conditions for extended periods may affect device reliability.

NOTE 1: The TTL input voltage ratings may be exceeded provided the input current ratings are observed.

recommended operating conditions

| | | MIN | NOM | MAX | UNIT | |
|----------|--------------------------------------|--------------------------|------|-------|-------|----|
| V_{CC} | TTL supply voltage | 4.5 | 5 | 5.5 | V | |
| V_{EE} | ECL supply voltage | –4.94 | –5.2 | –5.46 | V | |
| V_{IH} | TTL high-level input voltage | 2 | | | V | |
| V_{IL} | TTL low-level input voltage | | | 0.8 | V | |
| V_{IH} | ECL high-level input voltage‡ | $T_A = 0^\circ\text{C}$ | | –1170 | –840 | mV |
| | | $T_A = 25^\circ\text{C}$ | | –1130 | –810 | |
| | | $T_A = 75^\circ\text{C}$ | | –1070 | –735 | |
| V_{IL} | ECL low-level input voltage‡ | $T_A = 0^\circ\text{C}$ | | –1950 | –1480 | mV |
| | | $T_A = 25^\circ\text{C}$ | | –1950 | –1480 | |
| | | $T_A = 75^\circ\text{C}$ | | –1950 | –1450 | |
| I_{IK} | TTL input clamp current | | | –18 | mA | |
| I_{OH} | High-level output current | | | –15 | mA | |
| I_{OL} | Low-level output current | | | 48 | mA | |
| T_A | Operating free-air temperature range | 0 | | 75 | °C | |

‡ The algebraic convention, in which the least positive (most negative) value is designated minimum, is used in this data sheet for logic levels only.



SN10KHT5574

OCTAL ECL-TO-TTL TRANSLATOR WITH D-TYPE EDGE-TRIGGERED FLIP-FLOPS AND 3-STATE OUTPUTS

SDZS010 – JANUARY 1990 – REVISED OCTOBER 1990

electrical characteristics over recommended operating free-air temperature range (unless otherwise noted)

| PARAMETER | | TEST CONDITIONS | | MIN | TYP† | MAX | UNIT |
|-------------------|----------------------|---|-----------------------|------|------|------|------|
| V _{IK} | \overline{OE} only | V _{CC} = 4.5 V, V _{EE} = -4.94 V, I _I = -18 mA | | | | -1.2 | V |
| V _{OH} | | V _{CC} = 4.5 V, V _{EE} = -5.2 V ±5%, I _{OH} = -3 mA | | 2.4 | 3.3 | | V |
| | | V _{CC} = 4.5 V, V _{EE} = -5.2 V ±5%, I _{OH} = -15 mA | | 2 | 3.1 | | |
| V _{OL} | | V _{CC} = 4.5 V, V _{EE} = -5.2 V ±5%, I _{OL} = 48 mA | | | 0.38 | 0.55 | V |
| I _I | \overline{OE} only | V _{CC} = 5.5 V, V _{EE} = -5.46 V, V _I = 7 V | | | | 0.1 | mA |
| I _{IH} | \overline{OE} only | V _{CC} = 5.5 V, V _{EE} = -5.46 V, V _I = 2.7 V | | | | 20 | μA |
| I _{IL} | \overline{OE} only | V _{CC} = 5.5 V, V _{EE} = -5.46 V, V _I = 0.5 V | | | | -0.5 | mA |
| I _{IH} | Data inputs and CLK | V _{CC} = 5.5 V, V _{EE} = -5.46 V, V _I = -840 mV | T _A = 0°C | | | 350 | μA |
| | | V _{CC} = 5.5 V, V _{EE} = -5.46 V, V _I = -810 mV | T _A = 25°C | | | 350 | |
| | | V _{CC} = 5.5 V, V _{EE} = -5.46 V, V _I = -735 mV | T _A = 75°C | | | 350 | |
| I _{IL} | Data inputs and CLK | V _{CC} = 5.5 V, V _{EE} = -5.46 V, V _I = -1950 mV | T _A = 0°C | | | 0.5 | μA |
| | | | T _A = 25°C | | | 0.5 | |
| | | | T _A = 75°C | | | 0.5 | |
| I _{OZH} | | V _{CC} = 5.5 V, V _{EE} = -5.46 V, V _O = 2.7 V | | | | 50 | μA |
| I _{OZL} | | V _{CC} = 5.5 V, V _{EE} = -5.46 V, V _O = 0.5 V | | | | -50 | μA |
| I _{OS} ‡ | | V _{CC} = 5.5 V, V _{EE} = -5.46 V, V _O = 0 V | | -100 | | -225 | mA |
| I _{CCH} | | V _{CC} = 5.5 V, V _{EE} = -5.46 V | | | 66 | 95 | mA |
| I _{CCL} | | V _{CC} = 5.5 V, V _{EE} = -5.46 V | | | 76 | 110 | mA |
| I _{CCZ} | | V _{CC} = 5.5 V, V _{EE} = -5.46 V | | | 74 | 106 | mA |
| I _{EE} | | V _{CC} = 5.5 V, V _{EE} = -5.46 V | | | -43 | -61 | mA |
| C _i | | V _{CC} = 5.5 V, V _{EE} = -5.2 V, f = 10 MHz | | | 5 | | pF |
| C _o | | V _{CC} = 5.5 V, V _{EE} = -5.2 V, f = 10 MHz | | | 7 | | pF |

† All typical values are at V_{CC} = 5 V, V_{EE} = -5.2 V, T_A = 25°C.

‡ Not more than one output should be tested at a time, and the duration of the test should not exceed 10 ms.

timing requirements

| | | V _{CC} = 4.5 V to 5.5 V, V _{EE} = -4.94 V to -5.46 V, T _A = MIN to MAX§ | | UNIT |
|-----------------|------------------------|--|-----|------|
| | | MIN | MAX | |
| t _w | Pulse duration | CLK high | 4 | ns |
| | | CLK low | 4 | |
| t _{su} | Setup time before CLK↑ | Data high | 1 | ns |
| | | Data low | 1 | |
| t _h | Hold time after CLK↑ | Data high | 1 | ns |
| | | Data low | 1 | |

§ For conditions shown as MIN or MAX, use the appropriate value specified under recommended operating conditions.



SN10KHT5574
OCTAL ECL-TO-TTL TRANSLATOR WITH D-TYPE
EDGE-TRIGGERED FLIP-FLOPS AND 3-STATE OUTPUTS

SDZS010 – JANUARY 1990 – REVISED OCTOBER 1990

switching characteristics over recommended ranges of operating free-air temperature and supply voltage (see Figure 1)

| PARAMETER | FROM (INPUT) | TO (OUTPUT) | C _L = 50 pF, R1 = 500 Ω, R2 = 500 Ω | | | UNIT |
|------------------|-----------------|----------------|--|------|-----|------|
| | | | MIN | TYP† | MAX | |
| f _{max} | | | 200 | 300 | | MHz |
| t _{PLH} | CLK | Q | 2.3 | 4.1 | 7 | ns |
| t _{PHL} | | | 2.9 | 4.6 | 7.4 | |
| t _{PZH} | \overline{OE} | Q | 1.9 | 3.6 | 6.3 | ns |
| t _{PZL} | | | 2.7 | 4.8 | 7.7 | |
| t _{PHZ} | \overline{OE} | Q | 2.1 | 3.9 | 6.1 | ns |
| t _{PLZ} | | | 0.5 | 3.4 | 6.3 | |

† All typical values are at V_{CC} = 5 V, V_{EE} = -5.2 V, T_A = 25°C.



SN10KHT5574 OCTAL ECL-TO-TTL TRANSLATOR WITH D-TYPE EDGE-TRIGGERED FLIP-FLOPS AND 3-STATE OUTPUTS

SDZS010 – JANUARY 1990 – REVISED OCTOBER 1990

PARAMETER MEASUREMENT INFORMATION

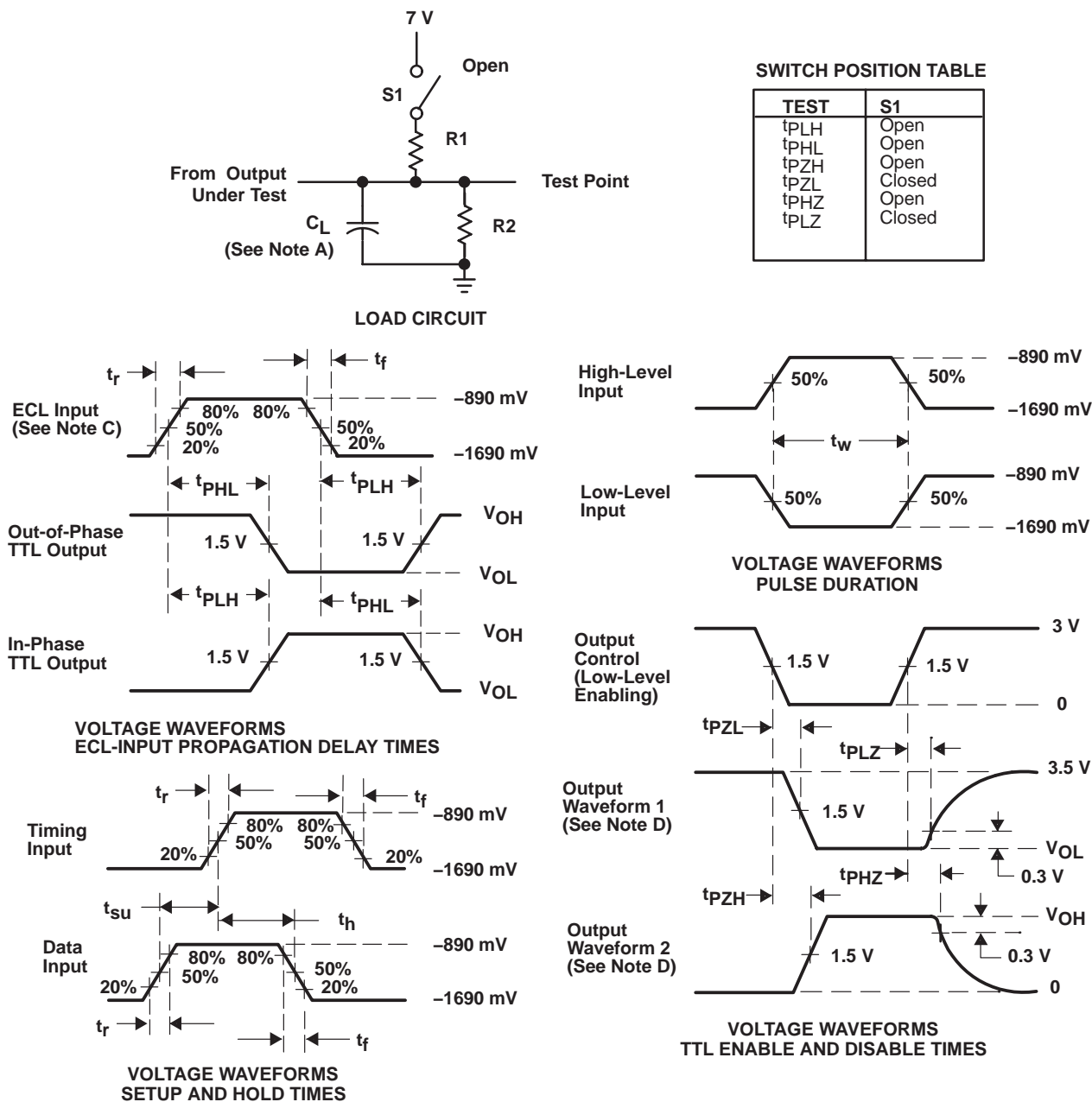

- NOTES: A. C_L includes probe and jig capacitance.
 B. For TTL inputs, input pulses are supplied by generators having the following characteristics PRR ≤ 10 MHz, Z₀ = 50 Ω, t_r ≤ 2.5 ns, t_f ≤ 2.5 ns.
 C. For ECL inputs, input pulses are supplied by generators having the following characteristics: PRR ≤ 10 MHz, Z₀ = 50 Ω, t_r ≤ 1.5 ns, t_f ≤ 1.5 ns.
 D. Waveform 1 is for an output with internal conditions such that the output is low except when disabled by the output control. Waveform 2 is for an output with internal conditions such that the output is high except when disabled by the output control.
 E. The outputs are measured one at a time with one transition per measurement.

Figure 1. Load circuit and voltage waveforms



PACKAGING INFORMATION

| Orderable Device | Status (1) | Package Type | Package Drawing | Pins | Package Qty | Eco Plan (2) | Lead/Ball Finish (6) | MSL Peak Temp (3) | Op Temp (°C) | Device Marking (4/5) | Samples |
|------------------|---------------|--------------|-----------------|------|-------------|-------------------------|-------------------------|----------------------|--------------|-------------------------|-------------------------|
| SN10KHT5574DW | ACTIVE | SOIC | DW | 24 | 25 | Green (RoHS & no Sb/Br) | CU NIPDAU | Level-1-260C-UNLIM | 0 to 70 | 10KHT5574 | Samples |
| SN10KHT5574DW | ACTIVE | SOIC | DW | 24 | 25 | Green (RoHS & no Sb/Br) | CU NIPDAU | Level-1-260C-UNLIM | 0 to 70 | 10KHT5574 | Samples |

(1) The marketing status values are defined as follows:

ACTIVE: Product device recommended for new designs.

LIFEBUY: TI has announced that the device will be discontinued, and a lifetime-buy period is in effect.

NRND: Not recommended for new designs. Device is in production to support existing customers, but TI does not recommend using this part in a new design.

PREVIEW: Device has been announced but is not in production. Samples may or may not be available.

OBsolete: TI has discontinued the production of the device.

(2) Eco Plan - The planned eco-friendly classification: Pb-Free (RoHS), Pb-Free (RoHS Exempt), or Green (RoHS & no Sb/Br) - please check <http://www.ti.com/productcontent> for the latest availability information and additional product content details.

TBD: The Pb-Free/Green conversion plan has not been defined.

Pb-Free (RoHS): TI's terms "Lead-Free" or "Pb-Free" mean semiconductor products that are compatible with the current RoHS requirements for all 6 substances, including the requirement that lead not exceed 0.1% by weight in homogeneous materials. Where designed to be soldered at high temperatures, TI Pb-Free products are suitable for use in specified lead-free processes.

Pb-Free (RoHS Exempt): This component has a RoHS exemption for either 1) lead-based flip-chip solder bumps used between the die and package, or 2) lead-based die adhesive used between the die and leadframe. The component is otherwise considered Pb-Free (RoHS compatible) as defined above.

Green (RoHS & no Sb/Br): TI defines "Green" to mean Pb-Free (RoHS compatible), and free of Bromine (Br) and Antimony (Sb) based flame retardants (Br or Sb do not exceed 0.1% by weight in homogeneous material)

(3) MSL, Peak Temp. - The Moisture Sensitivity Level rating according to the JEDEC industry standard classifications, and peak solder temperature.

(4) There may be additional marking, which relates to the logo, the lot trace code information, or the environmental category on the device.

(5) Multiple Device Markings will be inside parentheses. Only one Device Marking contained in parentheses and separated by a "~" will appear on a device. If a line is indented then it is a continuation of the previous line and the two combined represent the entire Device Marking for that device.

(6) Lead/Ball Finish - Orderable Devices may have multiple material finish options. Finish options are separated by a vertical ruled line. Lead/Ball Finish values may wrap to two lines if the finish value exceeds the maximum column width.

Important Information and Disclaimer: The information provided on this page represents TI's knowledge and belief as of the date that it is provided. TI bases its knowledge and belief on information provided by third parties, and makes no representation or warranty as to the accuracy of such information. Efforts are underway to better integrate information from third parties. TI has taken and continues to take reasonable steps to provide representative and accurate information but may not have conducted destructive testing or chemical analysis on incoming materials and chemicals. TI and TI suppliers consider certain information to be proprietary, and thus CAS numbers and other limited information may not be available for release.

In no event shall TI's liability arising out of such information exceed the total purchase price of the TI part(s) at issue in this document sold by TI to Customer on an annual basis.

DW (R-PDSO-G24)

PLASTIC SMALL OUTLINE

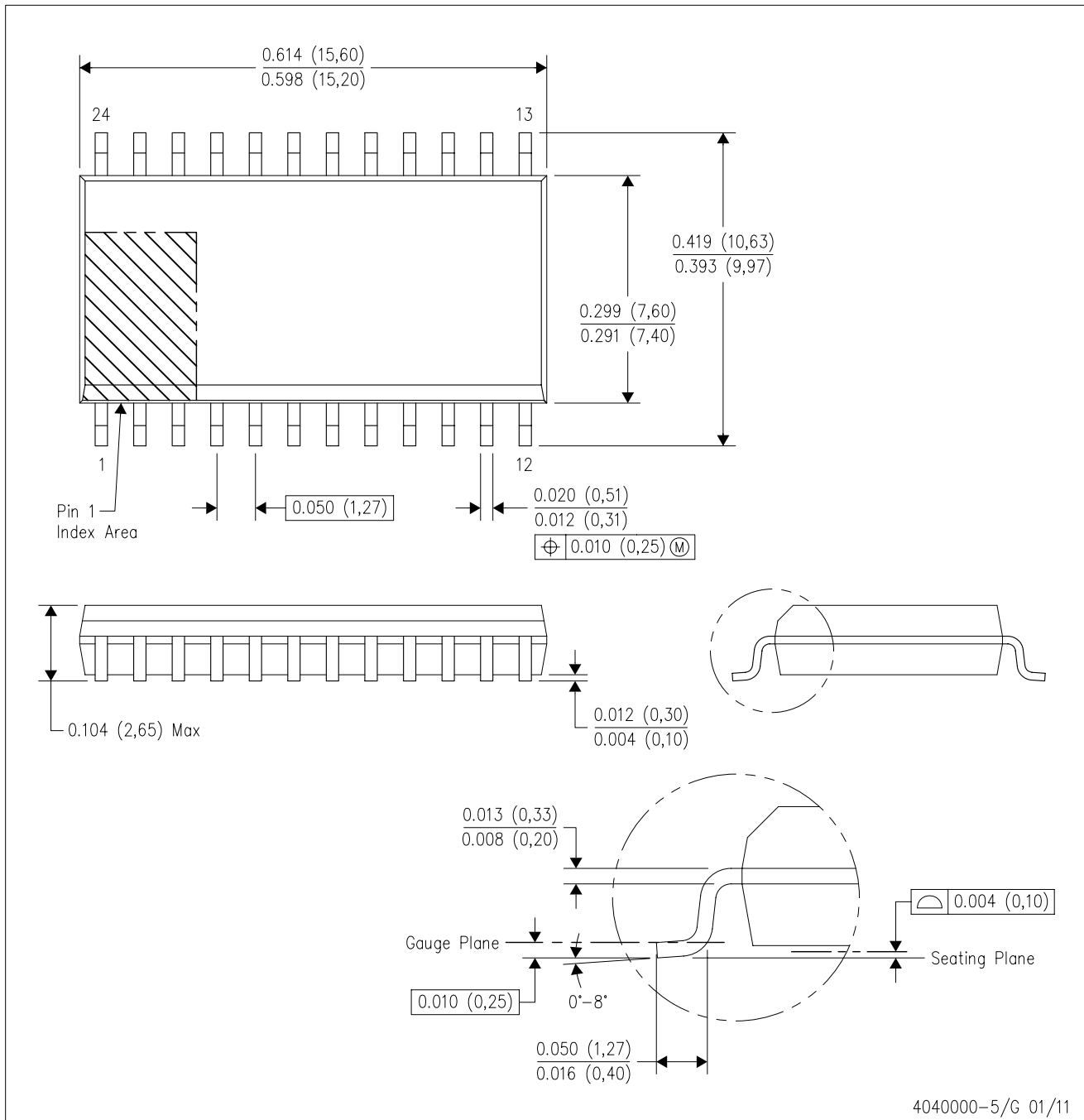

- NOTES:
- A. All linear dimensions are in inches (millimeters). Dimensioning and tolerancing per ASME Y14.5M-1994.
 - B. This drawing is subject to change without notice.
 - C. Body dimensions do not include mold flash or protrusion not to exceed 0.006 (0,15).
 - D. Falls within JEDEC MS-013 variation AD.

IMPORTANT NOTICE AND DISCLAIMER

TI PROVIDES TECHNICAL AND RELIABILITY DATA (INCLUDING DATASHEETS), DESIGN RESOURCES (INCLUDING REFERENCE DESIGNS), APPLICATION OR OTHER DESIGN ADVICE, WEB TOOLS, SAFETY INFORMATION, AND OTHER RESOURCES "AS IS" AND WITH ALL FAULTS, AND DISCLAIMS ALL WARRANTIES, EXPRESS AND IMPLIED, INCLUDING WITHOUT LIMITATION ANY IMPLIED WARRANTIES OF MERCHANTABILITY, FITNESS FOR A PARTICULAR PURPOSE OR NON-INFRINGEMENT OF THIRD PARTY INTELLECTUAL PROPERTY RIGHTS.

These resources are intended for skilled developers designing with TI products. You are solely responsible for (1) selecting the appropriate TI products for your application, (2) designing, validating and testing your application, and (3) ensuring your application meets applicable standards, and any other safety, security, or other requirements. These resources are subject to change without notice. TI grants you permission to use these resources only for development of an application that uses the TI products described in the resource. Other reproduction and display of these resources is prohibited. No license is granted to any other TI intellectual property right or to any third party intellectual property right. TI disclaims responsibility for, and you will fully indemnify TI and its representatives against, any claims, damages, costs, losses, and liabilities arising out of your use of these resources.

TI's products are provided subject to TI's Terms of Sale (www.ti.com/legal/termsofsale.html) or other applicable terms available either on ti.com or provided in conjunction with such TI products. TI's provision of these resources does not expand or otherwise alter TI's applicable warranties or warranty disclaimers for TI products.

Mailing Address: Texas Instruments, Post Office Box 655303, Dallas, Texas 75265
Copyright © 2019, Texas Instruments Incorporated

Looking for pricing, stock, or lifecycle information?

Click below to explore more details on WIN SOURCE:

 [View SN10KHT5574NT](#) on WIN SOURCE

 [Texas Instruments](#) Information

Optimize Your Supply Chain with WIN SOURCE Solutions

-  Global Sourcing Solution
-  Obsolete Management
-  Cost Control Management
-  Shortage Management
-  Alternative Solution
-  Excess Inventory Management