



**THE DATASHEET OF
SN65LVDS101DGKRG4**



SN65LVDx10x Differential Translator/Repeater

1 Features

- Designed for Signaling Rates ≥ 2 Gbps
- Total Jitter < 65 ps
- Low-Power Alternative for the MC100EP16
- Low 100-ps (Maximum) Part-to-Part Skew
- 25 mV of Receiver Input Threshold Hysteresis Over 0-V to 4-V Input Voltage Range
- Inputs Electrically Compatible With LVPECL, CML, and LVDS Signal Levels
- 3.3-V Supply Operation
- LVDT Integrates 110- Ω Terminating Resistor
- Offered in SOIC and MSOP

2 Applications

- Wireless Infrastructure
- Telecom Infrastructure
- Printers

3 Description

The SN65LVDS100, SN65LVDT100, SN65LVDS101, and SN65LVDT101 are high-speed differential receivers and drivers connected as repeaters. The receiver accepts low-voltage differential signaling (LVDS), positive-emitter-coupled logic (PECL), or current-mode logic (CML) input signals at rates up to 2 Gbps and repeats it as either an LVDS or PECL output signal. The signal path through the device is differential for low radiated emissions and minimal added jitter.

Device Information⁽¹⁾

PART NUMBER	PACKAGE	BODY SIZE (NOM)
SN65LVDS100	SOIC (8)	4.90 mm x 3.91 mm
	VSSOP (8)	3.00 mm x 3.00 mm
SN65LVDT100	SOIC (8)	4.90 mm x 3.91 mm
	VSSOP (8)	3.00 mm x 3.00 mm
SN65LVDS101	SOIC (8)	4.90 mm x 3.91 mm
	VSSOP (8)	3.00 mm x 3.00 mm
SN65LVDT101	SOIC (8)	4.90 mm x 3.91 mm
	VSSOP (8)	3.00 mm x 3.00 mm

(1) For all available packages, see the orderable addendum at the end of the data sheet.

FUNCTIONAL DIAGRAM

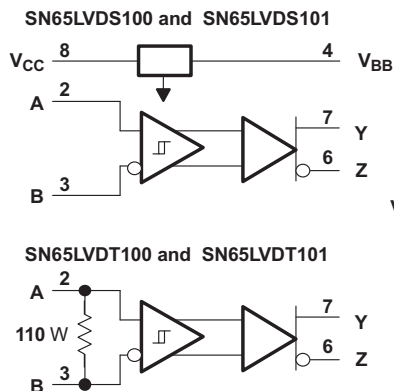

Dual Eye Diagram

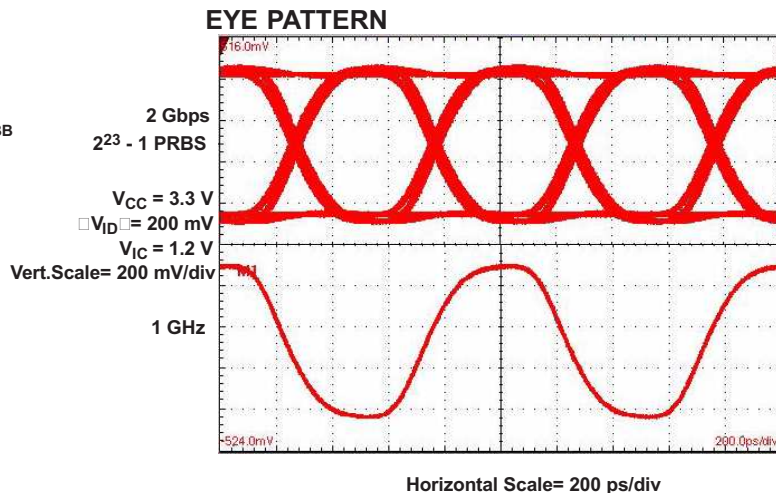

Table of Contents

1	Features	1	10.2	Functional Block Diagram	15
2	Applications	1	10.3	Feature Description	15
3	Description	1	10.4	Device Functional Modes	20
4	Revision History	2	11	Application and Implementation	21
5	Description (Continued)	3	11.1	Application Information	21
6	Device Options	3	11.2	Typical Application	22
7	Pin Configuration and Functions	3	12	Power Supply Recommendations	30
8	Specifications	4	13	Layout	30
8.1	Absolute Maximum Ratings	4	13.1	Layout Guidelines	30
8.2	ESD Ratings	4	13.2	Layout Example	32
8.3	Recommended Operating Conditions	4	14	Device and Documentation Support	33
8.4	Thermal Information	5	14.1	Related Links	33
8.5	Electrical Characteristics	5	14.2	Community Resources	33
8.6	Switching Characteristics	6	14.3	Trademarks	33
8.7	Typical Characteristics	7	14.4	Electrostatic Discharge Caution	33
9	Parameter Measurement Information	12	14.5	Glossary	33
10	Detailed Description	15	15	Mechanical, Packaging, and Orderable Information	33
10.1	Overview	15			

4 Revision History

Changes from Revision D (December 2014) to Revision E Page

- Changed *Features* From: "Over 0-V to 4-V Common-Mode Range" To: "Over 0-V to 4-V Input Voltage Range" **1**

Changes from Revision C (June 2004) to Revision D Page

- Added *Pin Configuration and Functions* section, *ESD Ratings* table, *Feature Description* section, *Device Functional Modes*, *Application and Implementation* section, *Power Supply Recommendations* section, *Layout* section, *Device and Documentation Support* section, and *Mechanical, Packaging, and Orderable Information* section **1**

5 Description (Continued)

The outputs of the SN65LVDS100 and SN65LVDT100 are LVDS levels as defined by TIA/EIA-644-A. The outputs of the SN65LVDS101 and SN65LVDT101 are compatible with 3.3-V PECL levels. Both drive differential transmission lines with nominally 100-Ω characteristic impedance.

The SN65LVDT100 and SN65LVDT101 include a 110-Ω differential line termination resistor for less board space, fewer components, and the shortest stub length possible. They do not include the V_{BB} voltage reference found in the SN65LVDS100 and SN65LVDS101. V_{BB} provides a voltage reference of typically 1.35 V below V_{CC} for use in receiving single-ended input signals and is particularly useful with single-ended 3.3-V PECL inputs. When V_{BB} is not used, it should be unconnected or open.

All devices are characterized for operation from -40°C to 85°C .

6 Device Options

ORDERABLE PART NUMBER	OUTPUT	TERMINATION RESISTOR	V_{BB}
SN65LVDS100D	LVDS	No	Yes
SN65LVDS100DGK	LVDS	No	Yes
SN65LVDT100D	LVDS	Yes	No
SN65LVDT100DGK	LVDS	Yes	No
SN65LVDS101D	LVPECL	No	Yes
SN65LVDS101DGK	LVPECL	No	Yes
SN65LVDT101D	LVPECL	Yes	No
SN65LVDT101DGK	LVPECL	Yes	No

7 Pin Configuration and Functions

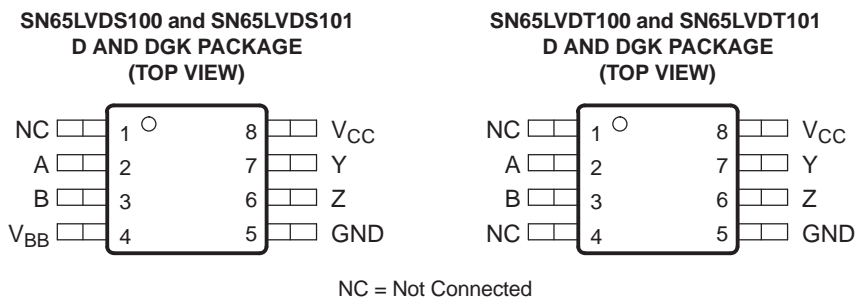

Pin Functions

NAME	PIN		I/O	DESCRIPTION
	SN65LVDS100, SN65LVDS101	SN65LVDT100, SN65LVDT101		
A	2	2	I	Differential non-inverting input
B	3	3	I	Differential inverting input
GND	5	5	—	Ground
NC	1	1, 4	—	No connect
V_{BB}	4	—	O	Voltage reference
V_{CC}	8	8	—	Supply voltage
Y	7	7	O	Differential non-inverting output
Z	6	6	O	Differential inverting output

8 Specifications

8.1 Absolute Maximum Ratings⁽¹⁾

over operating free-air temperature range unless otherwise noted

		MIN	MAX	UNIT
V_{CC}	Supply voltage range ⁽²⁾	-0.5	4	V
I_{BB}	V_{BB} output current	-0.5	0.5	mA
V_I	Voltage range, (A, B, Y, Z)	0	4.3	V
V_O				
V_{ID}	Differential voltage, $ V_A - V_B $ ('LVDT100 and 'LVDT101 only)		1	V

- (1) Stresses beyond those listed under Absolute Maximum Ratings may cause permanent damage to the device. These are stress ratings only, and functional operation of the device at these or any other conditions beyond those indicated under [Recommended Operating Conditions](#) is not implied. Exposure to absolute-maximum-rated conditions for extended periods may affect device reliability.
- (2) All voltage values, except differential I/O bus voltages, are with respect to network ground terminal.

8.2 ESD Ratings

			VALUE	UNIT	
$V_{(ESD)}$	Electrostatic discharge	Human body model (HBM), per ANSI/ESDA/JEDEC JS-001 ⁽¹⁾	Pins 2, 3, 5, 6, 7	±5000	V
			All pins except 2, 3, 5, 6, 7	±2000	V
		Charged-device model (CDM), per JEDEC specification JESD22-C101 ⁽²⁾		±1500	V

- (1) Tested in accordance with JEDEC Standard 22, Test Method A114-A.7.
- (2) Tested in accordance with JEDEC Standard 22, Test Method C101.

8.3 Recommended Operating Conditions

		MIN	NOM	MAX	UNIT
Supply voltage, V_{CC}		3	3.3	3.6	V
Magnitude of differential input voltage $ V_{ID} $	'LVDS100 or 'LVDS101	0.1		1	V
	'LVDT100 or 'LVDT101	0.1		0.8	
Input voltage (any combination of common-mode or input signals), V_I		0		4	V
V_{BB} output current, $I_{O(VBB)}$		-400 ⁽¹⁾		12	µA
Operating free-air temperature, T_A		-40		85	°C

- (1) The algebraic convention, in which the less positive (more negative) limit is designated minimum, is used in this data sheet.

8.4 Thermal Information

THERMAL METRIC ⁽¹⁾		SN65LVDS100, SN65LVDT100, SN65LVDS101, SN65LVDT101		UNIT
		D	DGK	
		8 PINS	8 PINS	
R _{θJA}	Junction-to-ambient thermal resistance	208	263	°C/W
	Power dissipation rating: T _A ≤ 25°C	151	377	mW
	Power dissipation rating: T _A ≤ 85°C	192	481	

(1) For more information about traditional and new thermal metrics, see the *IC Package Thermal Metrics* application report, [SPRA953](#).

8.5 Electrical Characteristics

over recommended operating conditions (unless otherwise specified)

PARAMETER		TEST CONDITIONS	MIN	TYP ⁽¹⁾	MAX	UNIT
I _{CC}	Supply current, 'LVDx100	No load or input		25	30	mA
	Supply current, 'LVDx101	R _L = 50 Ω to 1 V, No input		50	61	
P _D	Device power dissipation, 'LVDx100	R _L = 100 Ω, No input			110	mW
	Device power dissipation, 'LVDx101	Y and Z to V _{CC} – 2 V through 50 Ω No input		116	142	
V _{BB}	Reference voltage output, 'LVDS100 or 'LVDS101	I _O = –400 μA or 12 μA	V _{CC} – 1.4	V _{CC} – 1.35	V _{CC} – 1.3	mV
SN65LVDS100 and SN65LVDS101 INPUT CHARACTERISTICS (see Figure 30)						
V _{IT+}	Positive-going differential input voltage threshold	See Figure 30 and Table 1			100	mV
V _{IT–}	Negative-going differential input voltage threshold		–100			
I _I	Input current	V _I = 0 V or 2.4 V Second input at 1.2 V	–20		20	μA
		V _I = 4 V, Second input at 1.2 V			33	μA
I _{I(OFF)}	Power off input current	V _{CC} = 1.5 V, V _I = 0 V or 2.4 V Second input at 1.2 V	–20		20	μA
		V _{CC} = 1.5 V, V _I = 4 V Second input at 1.2 V			33	
I _{IO}	Input offset current (I _{IA} – I _{IB})	V _{IA} = V _{IB} , 0 ≤ V _{IA} ≤ 4 V	–6		6	μA
C _i	Small-signal input capacitance to GND	V _I = 1.2 V		0.6		pF
SN65LVDT100 and SN65LVDT101 INPUT CHARACTERISTICS (see Figure 30)						
V _{IT+}	Positive-going differential input voltage threshold	See Figure 30 and Table 1			100	mV
V _{IT–}	Negative-going differential input voltage threshold		–100			
I _I	Input current	V _I = 0 V or 2.4 V, Other input open	–40		40	μA
		V _I = 4 V, Other input open			66	
I _{I(OFF)}	Power off input current	V _{CC} = 1.5 V, V _I = 0 V or 2.4 V Other input open	–40		40	μA
		V _{CC} = 1.5 V, V _I = 4 V Other input open			66	
R _(T)	Differential input resistance	V _{ID} = 300 mV or 500 mV V _{IC} = 0 V or 2.4 V	90	110	132	Ω
		V _{CC} = 0 V, V _{ID} = 300 mV or 500 mV V _{IC} = 0 V or 2.4 V	90	110	132	
C _i	Small-signal differential input capacitance	V _I = 1.2 V		0.6		pF

(1) Typical values are with a 3.3-V supply voltage and room temperature

Electrical Characteristics (continued)

over recommended operating conditions (unless otherwise specified)

PARAMETER		TEST CONDITIONS	MIN	TYP ⁽¹⁾	MAX	UNIT
SN65LVDS100 and SN65LVDT100 OUTPUT CHARACTERISTICS (see Figure 30)						
V _{OD}	Differential output voltage magnitude	See Figure 31	247	340	454	mV
Δ V _{OD}	Change in differential output voltage magnitude between logic states		–50		50	
V _{OC(SS)}	Steady-state common-mode output voltage	See Figure 32	1.125		1.375	V
ΔV _{OC(SS)}	Change in steady-state common-mode output voltage between logic states		–50		50	mV
V _{OC(PP)}	Peak-to-peak common-mode output voltage			50	150	mV
I _{OS}	Short-circuit output current	V _{O(Y)} or V _{O(Z)} = 0 V	–24		24	mA
I _{OS(D)}	Differential short-circuit output current	V _{OD} = 0 V	–12		12	mA
SN65LVDS101 and SN65LVDT101 OUTPUT CHARACTERISTICS (see Figure 30)						
V _{OH}	High-level output voltage	50 Ω to V _{CC} – 2 V, See Figure 39	V _{CC} – 1.25	V _{CC} – 1.02	V _{CC} – 0.9	V
		V _{CC} = 3.3 V, 50-Ω load to 2.3 V	2055	2280	2405	mV
V _{OL}	Low-level output voltage	50 Ω to V _{CC} – 2 V, See Figure 39	V _{CC} – 1.83	V _{CC} – 1.61	V _{CC} – 1.53	V
		V _{CC} = 3.3 V, 50-Ω load to 2.3 V	1475	1690	1775	mV
V _{OD}	Differential output voltage magnitude	50-Ω load to V _{CC} – 2 V, See Figure 39	475	575	750	mV

8.6 Switching Characteristics

over recommended operating conditions (unless otherwise noted)

PARAMETER		TEST CONDITIONS	MIN	TYP ⁽¹⁾	MAX	UNIT	
t _{PLH}	Propagation delay time, low-to-high-level output	'LVDx100	300	470	800	ps	
		'LVDx101	400	630	900		
t _{PHL}	Propagation delay time, high-to-low-level output	'LVDx100	300	470	800	ps	
		'LVDx100	400	630	900		
t _r	Differential output signal rise time (20% to 80%)	See Figure 33			220	ps	
t _f	Differential output signal fall time (20% to 80%)				220	ps	
t _{sk(p)}	Pulse skew ((t _{PHL} – t _{PLH})) ⁽²⁾			5	50	ps	
t _{sk(pp)}	Part-to-part skew ⁽³⁾		V _{ID} = 0.2 V, See Figure 33			100	ps
t _{jit(per)}	RMS period jitter ⁽⁴⁾		1 GHz 50% duty-cycle square-wave input		1	3.7	ps
t _{jit(cc)}	Peak cycle-to-cycle jitter ⁽⁵⁾	V _{ID} = 200 mV, V _{IC} = 1.2 V See Figure 34		6	23	ps	
t _{jit(pp)}	Peak-to-peak jitter	2 GHz PRBS, 2 ²³ – 1 run length V _{ID} = 200 mV, V _{IC} = 1.2 V See Figure 34		28	65	ps	
t _{jit(det)}	Peak-to-peak deterministic jitter ⁽⁶⁾	2 GHz PRBS, 2 ⁷ – 1 run length V _{ID} = 200 mV, V _{IC} = 1.2 V See Figure 34		17	48	ps	

(1) All typical values are at 25°C and with a 3.3-V supply.

 (2) t_{sk(p)} is the magnitude of the time difference between the t_{PLH} and t_{PHL} of any output of a single device.

 (3) t_{sk(pp)} is the magnitude of the time difference in propagation delay time between any specified terminals of two devices when both devices operate with the same supply voltages, at the same temperature, and have identical packages and test circuits.

(4) Period jitter is the deviation in cycle time of a signal with respect to the ideal period over a random sample of 1,000,000 cycles.

(5) Cycle-to-cycle jitter is the variation in cycle time of a signal between adjacent cycles, over a random sample of 1,000 adjacent cycle pairs.

(6) Deterministic jitter is the sum of pattern-dependent jitter and pulse-width distortion.

8.7 Typical Characteristics

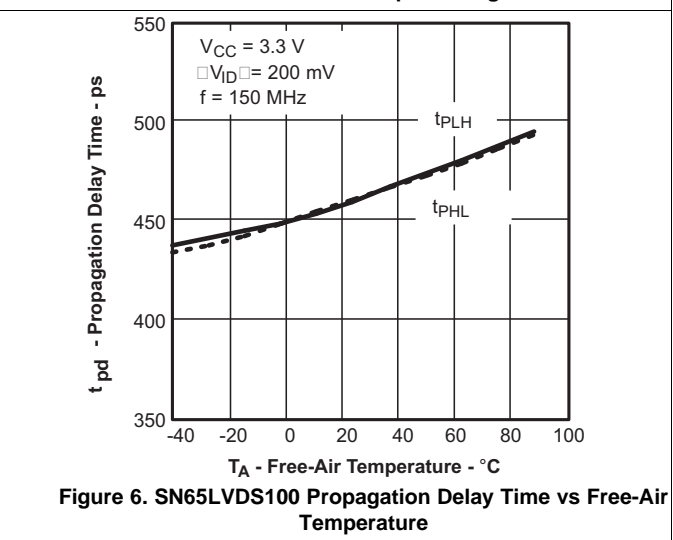
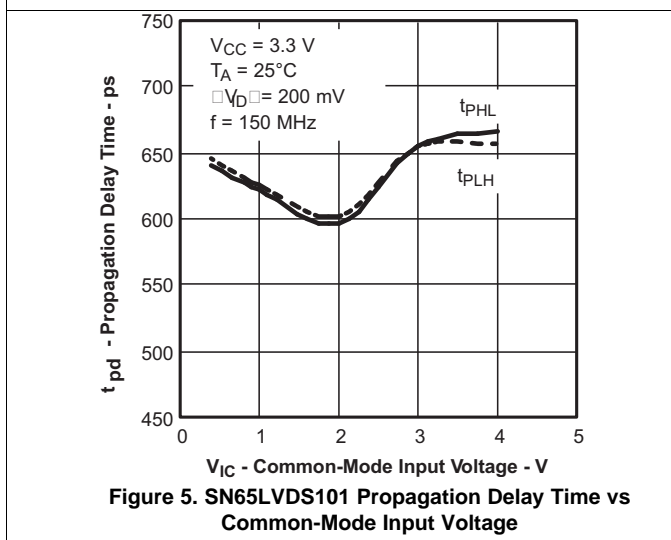
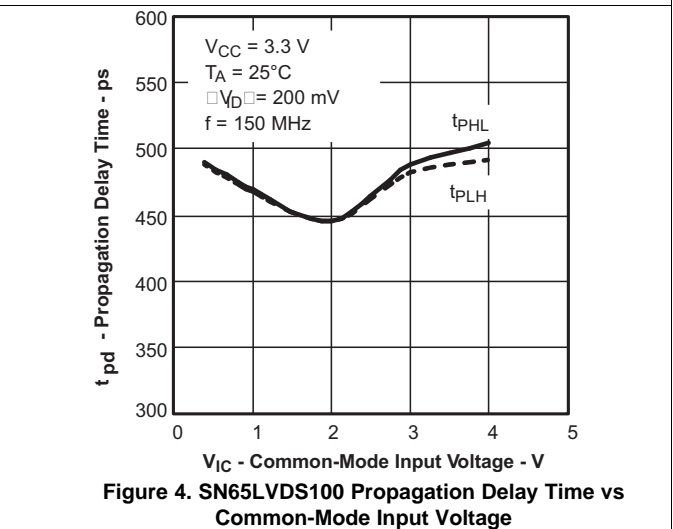
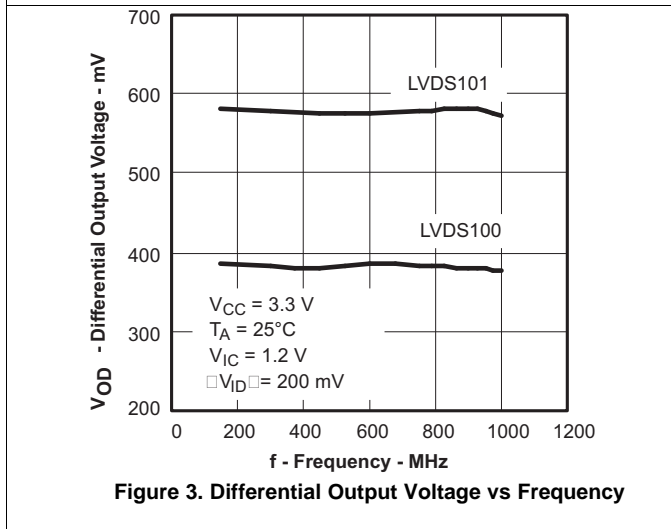
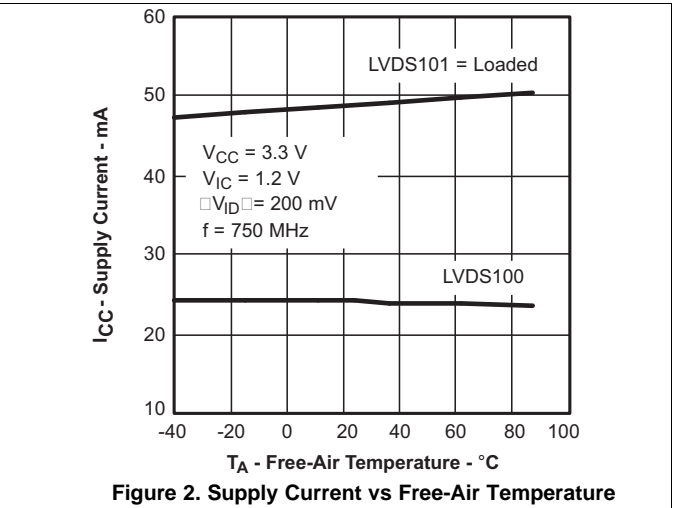
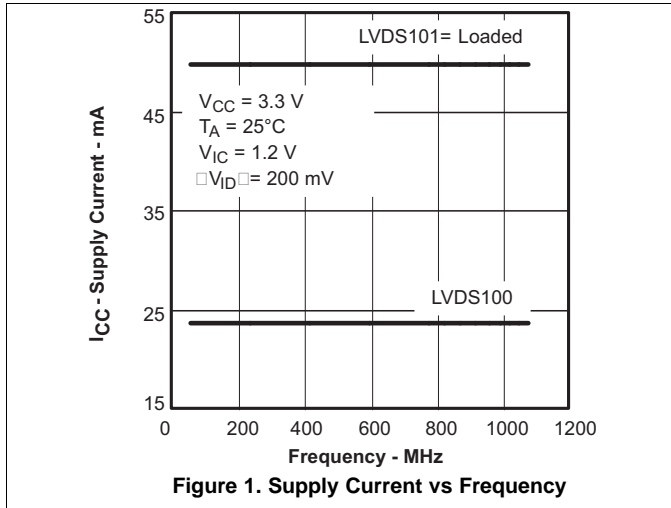

Typical Characteristics (continued)

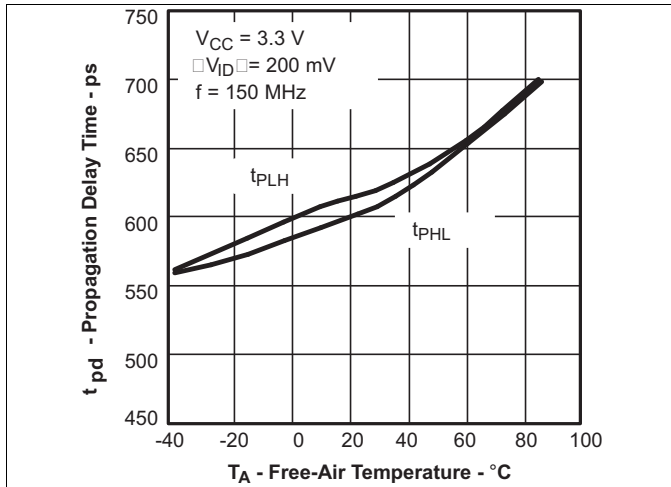

Figure 7. SN65LVDS101 Propagation Delay Time vs Free-Air Temperature

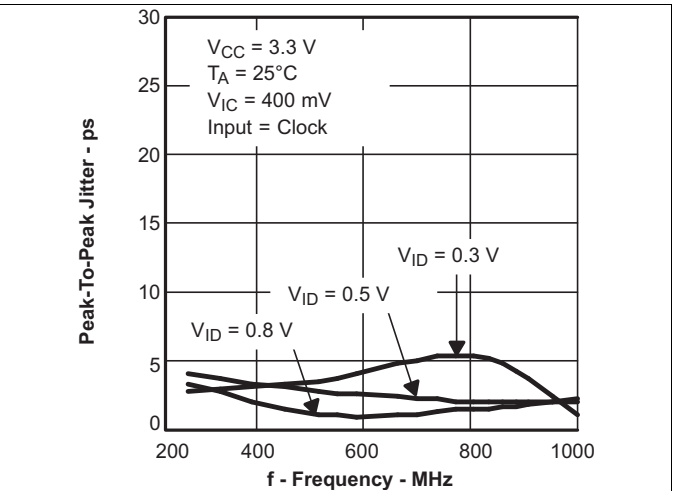

Figure 8. SN65LVDS100 Peak-to-Peak Jitter vs Frequency

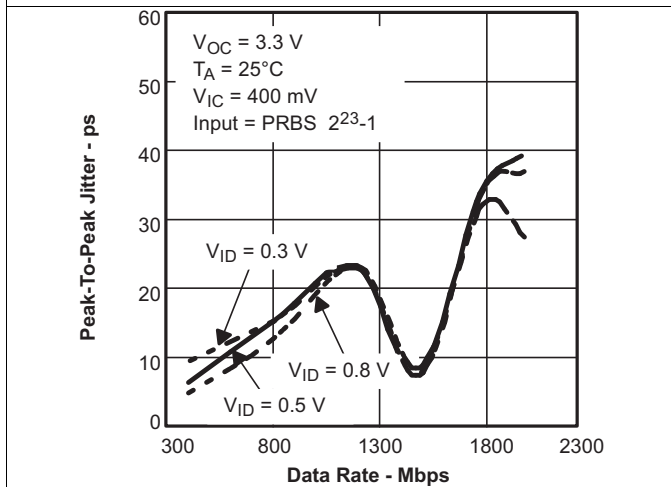

Figure 9. SN65LVDS100 Peak-to-Peak Jitter vs Data Rate

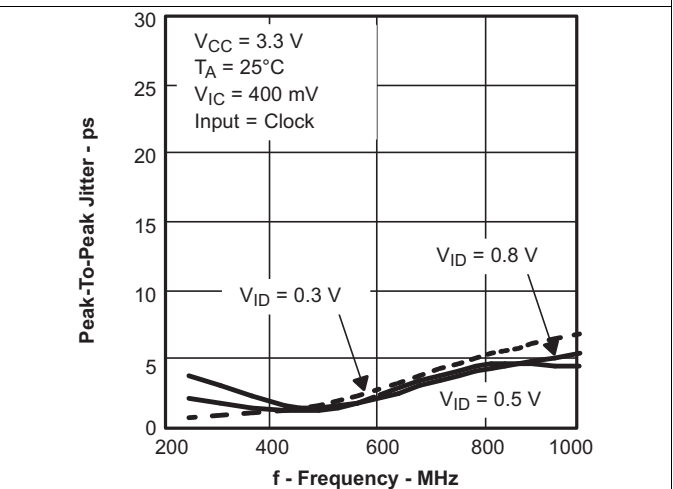

Figure 10. SN65LVDS101 Peak-to-Peak Jitter vs Frequency

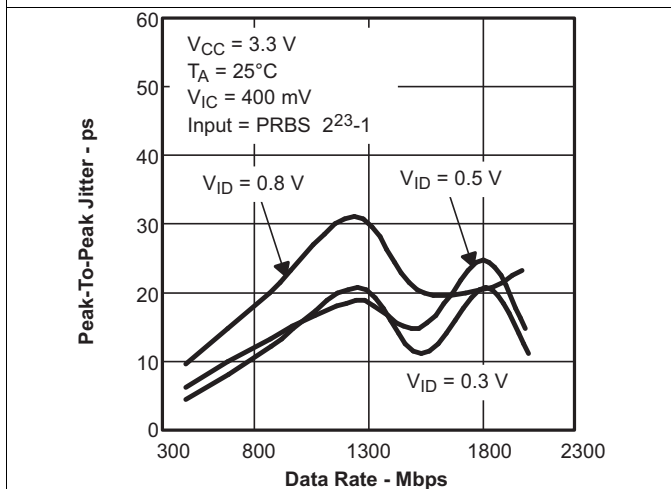

Figure 11. SN65LVDS101 Peak-to-Peak Jitter vs Data Rate

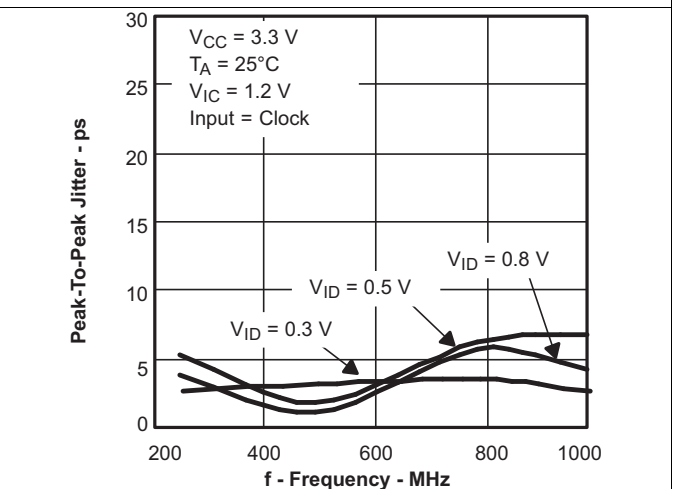

Figure 12. SN65LVDS100 Peak-to-Peak Jitter vs Frequency

Typical Characteristics (continued)

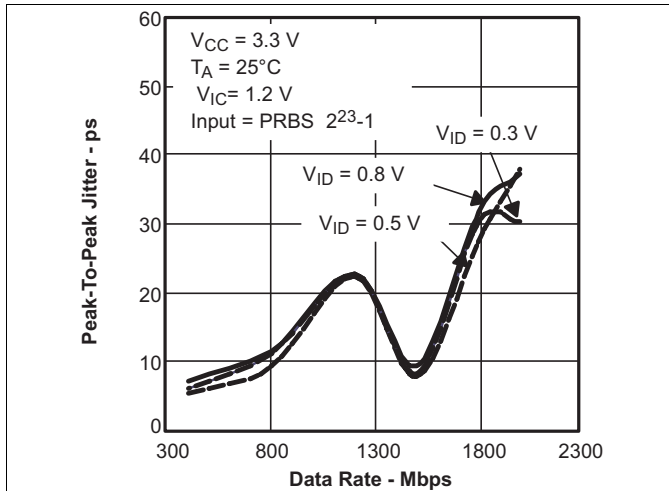

Figure 13. SN65LVDS100 Peak-to-Peak Jitter vs Data Rate

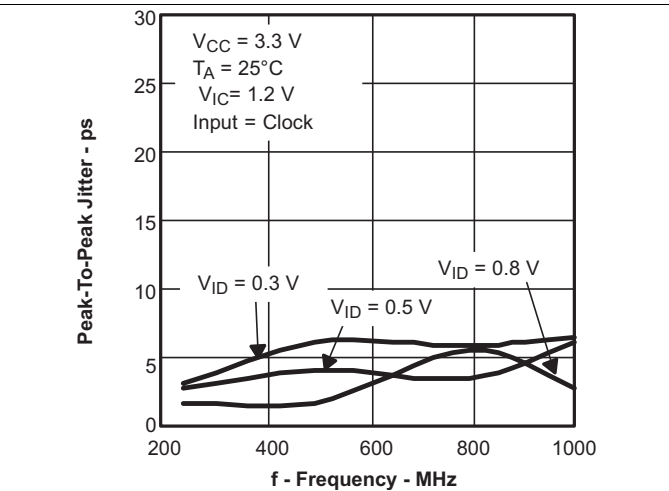

Figure 14. SN65LVDS101 Peak-to-Peak Jitter vs Frequency

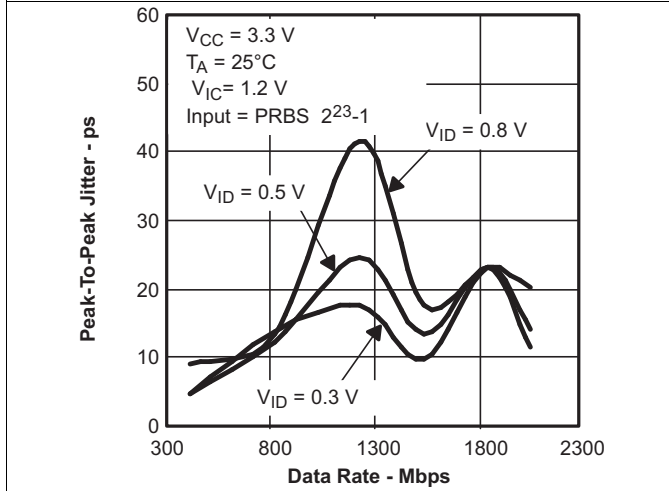

Figure 15. SN65LVDS101 Peak-to-Peak Jitter vs Data Rate

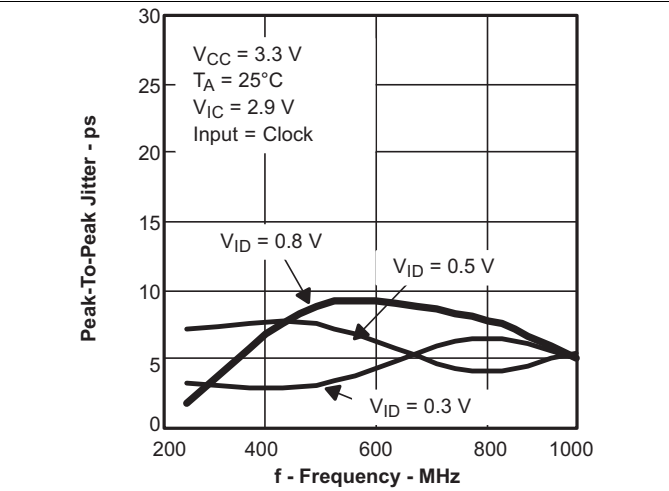

Figure 16. SN65LVDS100 Peak-to-Peak Jitter vs Frequency

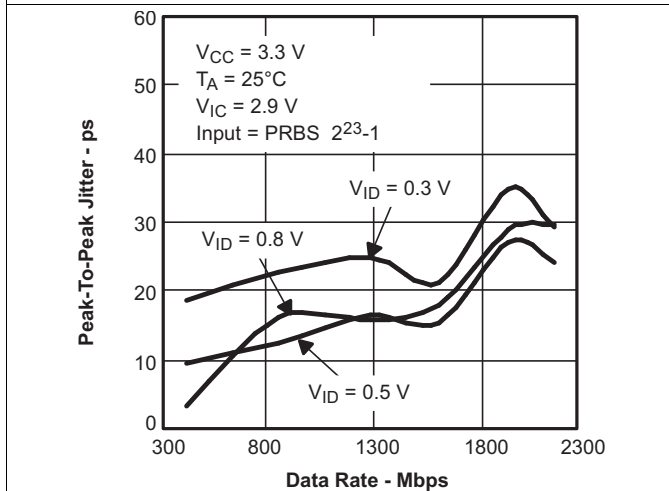

Figure 17. SN65LVDS100 Peak-to-Peak Jitter vs Data Rate

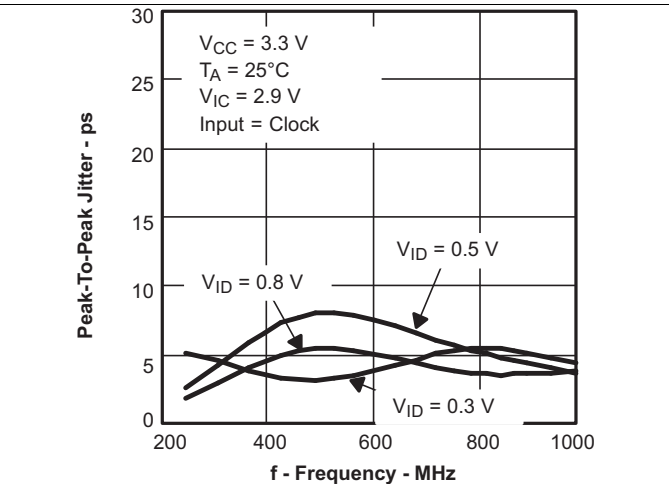

Figure 18. SN65LVDS101 Peak-to-Peak Jitter vs Frequency

Typical Characteristics (continued)

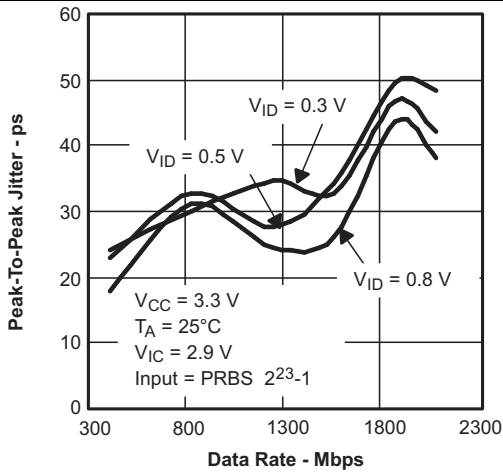

Figure 19. SN65LVDS101 Peak-to-Peak Jitter vs Data Rate

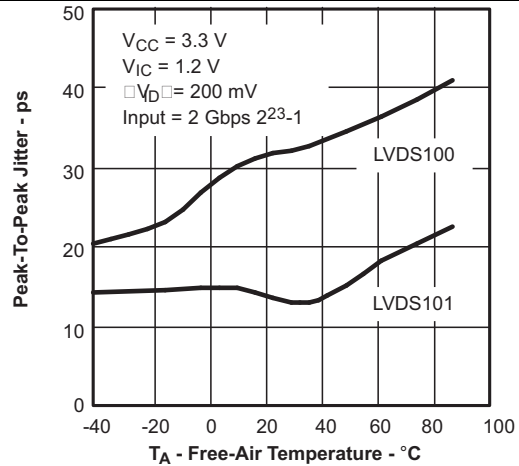

Figure 20. SN65LVDS100 Peak-to-Peak Jitter vs Free-Air Temperature

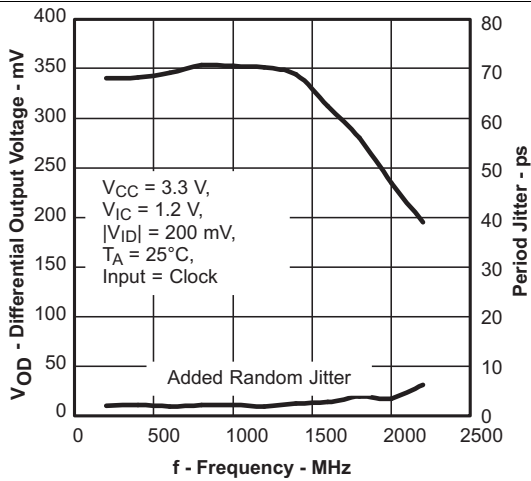

Figure 21. SN65LVDS100 Differential Output Voltage vs Frequency

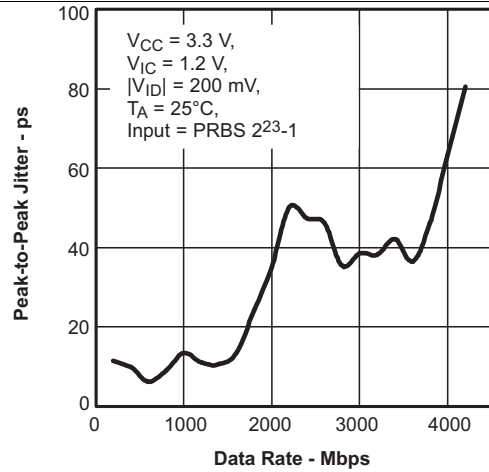

Figure 22. SN65LVDS100 Peak-to-Peak Jitter vs Data Rate

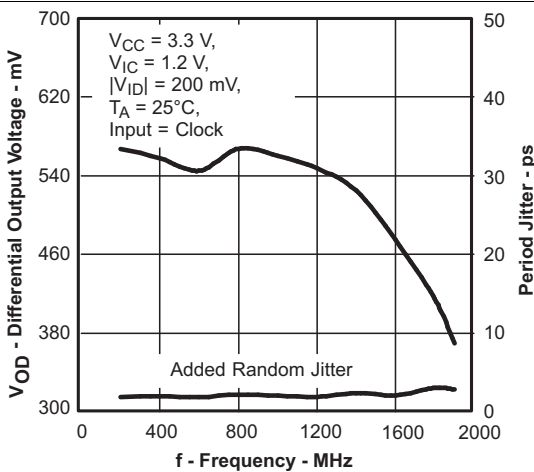

Figure 23. SN65LVDS101 Differential Output Voltage vs Frequency

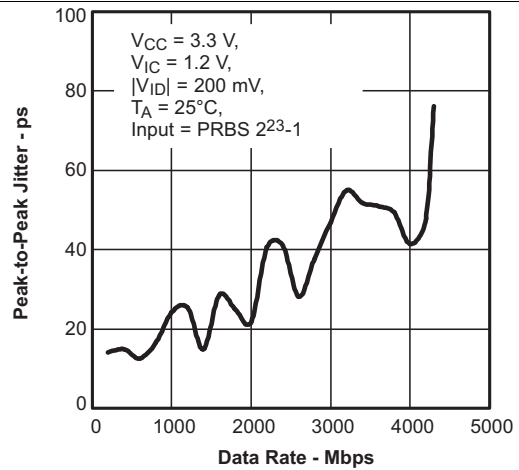
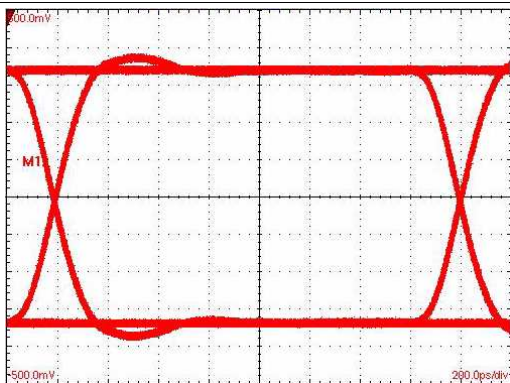

Figure 24. SN65LVDS101 Peak-to-Peak Jitter vs Data Rate

Typical Characteristics (continued)



Horizontal Scale= 200 ps/div
LVPECL-to-LVDS

Figure 25. SN65LVDS100 Mbps, $2^{23} - 1$ PRBS

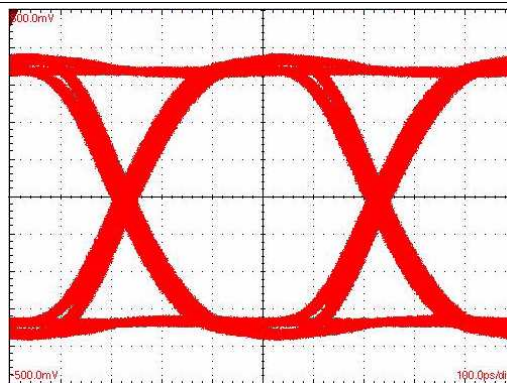

Horizontal Scale= 100 ps/div
LVPECL-to-LVDS

Figure 26. SN65LVDS100 Gbps, $2^{23} - 1$ PRBS

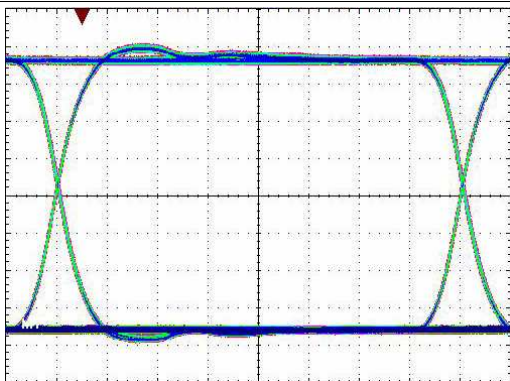

Horizontal Scale= 200 ps/div
LVDS-to-LVPECL

Figure 27. SN65LVDS101 Mbps, $2^{23} - 1$ PRBS

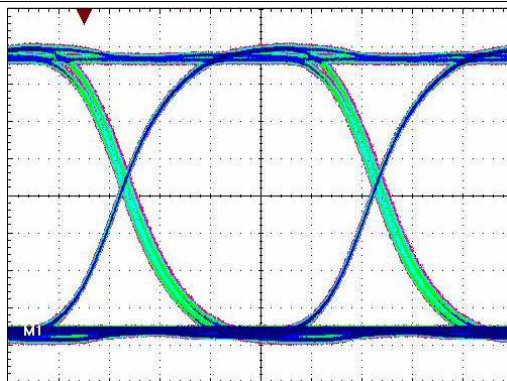

Horizontal Scale= 100 ps/div
LVDS-to-LVPECL

Figure 28. SN65LVDS101 Gbps, $2^{23} - 1$ PRBS

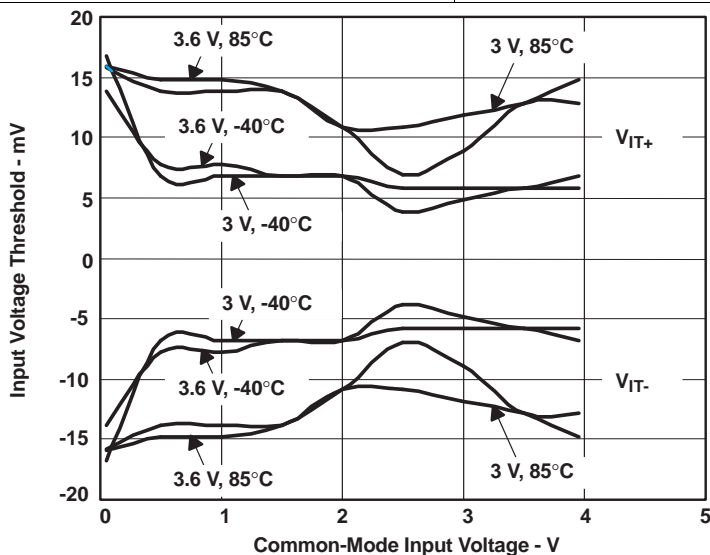

$|V_{OD}| = 250 \text{ mV}$,
 $R_L = 100 \Omega$,
Nominal Process

V_{IT} is a steady-state parameter. The switching time is influenced by the input overdrive above this steady-state threshold up to a differential input voltage magnitude of 100 mV.

Figure 29. SN65LVDS100 Simulated Input Voltage Threshold vs Common-Mode Input Voltage, Supply Voltage, and Temperature

9 Parameter Measurement Information

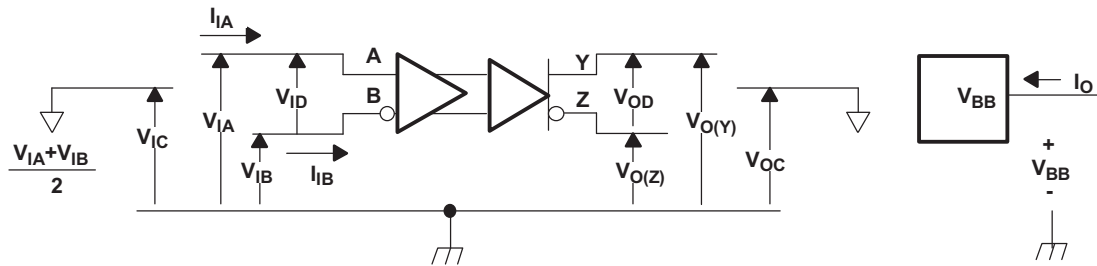

Figure 30. Voltage and Current Definitions

Table 1. Receiver Input Voltage Threshold Test

APPLIED VOLTAGES		RESULTING DIFFERENTIAL INPUT VOLTAGE	RESULTING COMMON-MODE INPUT VOLTAGE	OUTPUT ⁽¹⁾
V _{IA}	V _{IB}	V _{ID}	V _{IC}	
1.25 V	1.15 V	100 mV	1.2 V	H
1.15 V	1.25 V	-100 mV	1.2 V	L
4.0 V	3.9 V	100 mV	3.95 V	H
3.9 V	4.0 V	-100 mV	3.95 V	L
0.1 V	0.0 V	100 mV	0.05 V	H
0.0 V	0.1 V	-100 mV	0.05 V	L
1.7 V	0.7 V	1000 mV	1.2 V	H
0.7 V	1.7 V	-1000 mV	1.2 V	L
4.0 V	3.0 V	1000 mV	3.5 V	H
3.0 V	4.0 V	-1000 mV	3.5 V	L
1.0 V	0.0 V	1000 mV	0.5 V	H
0.0 V	1.0 V	-1000 mV	0.5 V	L

(1) H = high level, L = low level

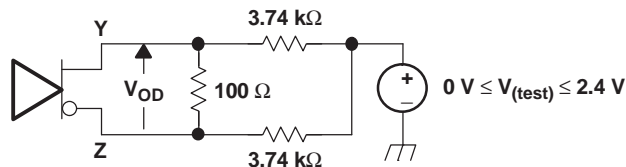
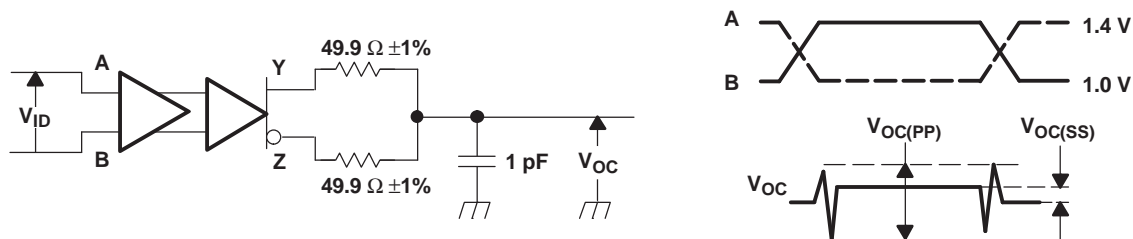
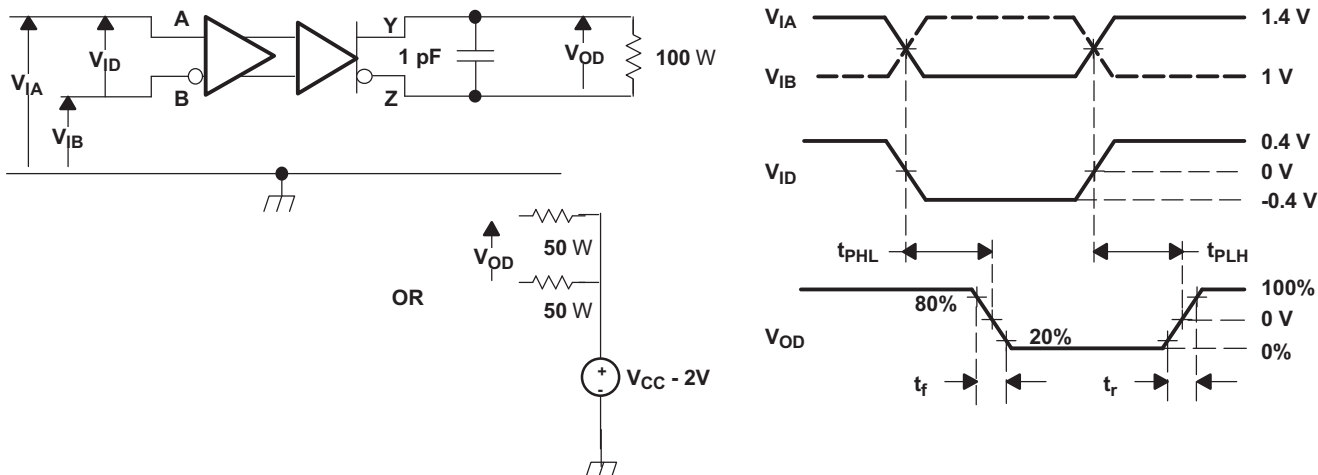

Figure 31. SN65LVDSx100 Differential Output Voltage (V_{OD}) Test Circuit



NOTE: All input pulses are supplied by a generator having the following characteristics: t_r or $t_f \leq 0.25$ ns, pulse repetition rate (PRR) = 0.5 Mpps, pulse width = 500 ± 10 ns. C_L includes instrumentation and fixture capacitance within 0.06 mm of the device under test. The measurement of $V_{OC(PP)}$ is made on test equipment with a -3 dB bandwidth of at least 300 MHz.

Figure 32. Test Circuit and Definitions for the SN65LVDSx100 Driver Common-Mode Output Voltage



NOTE: All input pulses are supplied by a generator having the following characteristics: t_r or $t_f \leq 0.25$ ns, pulse repetition rate (PRR) = 50 Mpps, pulse width = 10 ± 0.2 ns. C_L includes instrumentation and fixture capacitance within 0.06 mm of the device under test. Measurement equipment provides a bandwidth of 5 GHz minimum.

Figure 33. Timing Test Circuit and Waveforms

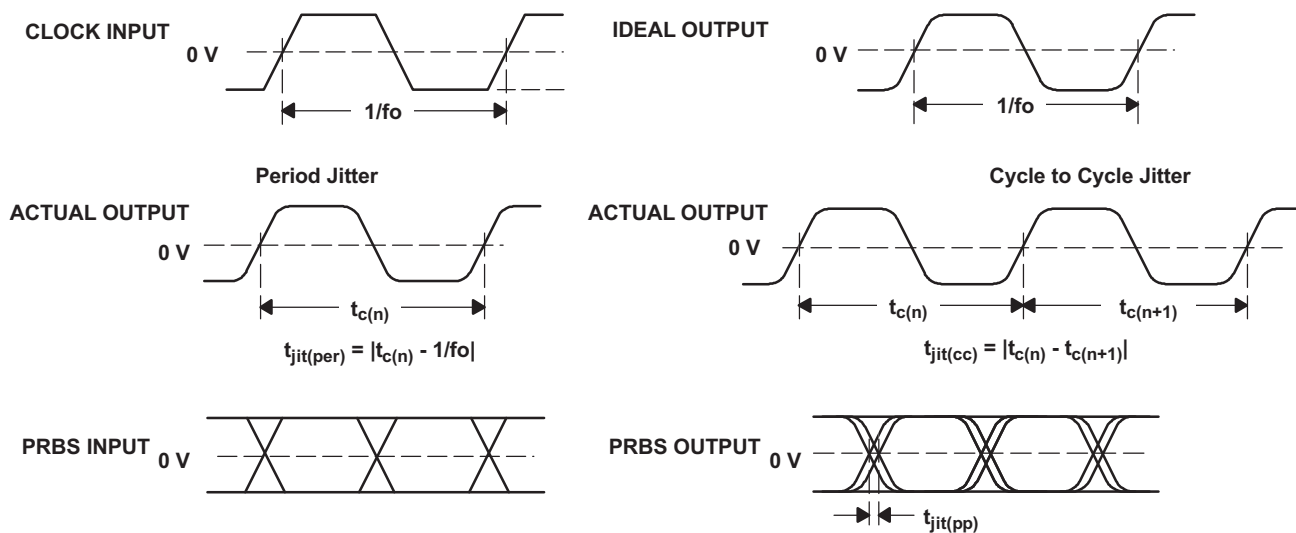
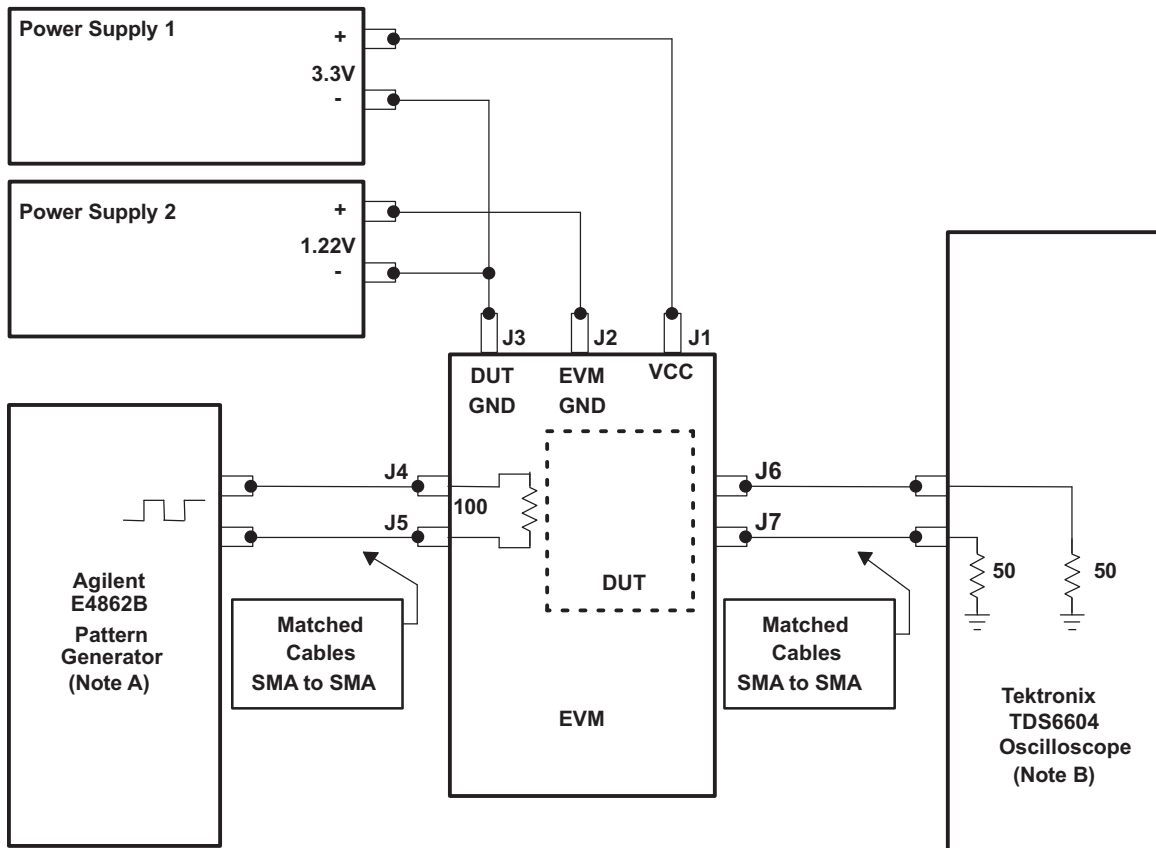

Figure 34. Driver Jitter Measurement Waveforms



- A. Source jitter is subtracted from the measured values.
- B. TDS JIT3 jitter analysis software installed

Figure 35. Jitter Setup Connections for SN65LVDS100 and SN65LVDS101

10 Detailed Description

10.1 Overview

The SN65LVDS100 family of devices are fully differential, high-speed translators/repeaters. All devices in the family include a wide common-mode range receiver that accepts low-voltage differential signals covering a variety of standards. A receiver with an input sensitivity of ± 100 mV and 25 mV of hysteresis is incorporated. The SN65LVDS100 devices include an output driver that meets all the specifications of the LVDS standard (TIA/EIA-644A). The SN65LVDS101 devices include an output driver that is compatible with 3.3-V PECL levels.

The SN65LVDS100 family is intended to drive a 100- Ω transmission line. This transmission line may be a printed-circuit board (PCB) or cabled interconnect. With transmission lines, optimum signal quality and power delivery is reached when a transmission line is terminated with a load equal to the characteristic impedance of the interconnecting media. Likewise, the driven 100- Ω transmission line should be terminated with a matched resistance.

10.2 Functional Block Diagram

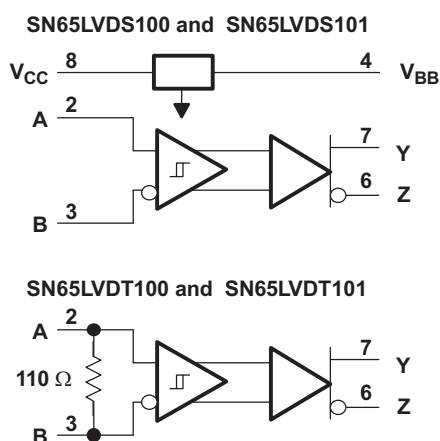

10.3 Feature Description

10.3.1 Receiver Features

10.3.1.1 Voltage Range and Common-Mode Range

The receiver circuit incorporated into the SN65LVDS100 family supports receiving most low-voltage differential signals. This wide common-mode range receiver can accept any input signal between 0 and 4 V. Without referencing any specific standard, we can analyze the range of signals that can be input to this family of devices. Assuming an input signal has a 400-mV differential input voltage $|(V^+ - V^-)|$, the maximum recommended input voltage is 4 V. The absolute value of the most positive signal of a differential input would be V_{MAX} :

$$V_{MAX} = V_{CM} + \frac{1}{2} (V_{DIFF})$$

where

- V_{CM} = common-mode voltage
- V_{DIFF} = differential voltage

(1)

Therefore, using our V_{MAX} of 4 V and V_{DIFF} of 400 mV, we see that we can simultaneously support a differential voltage of 400 mV and a common-mode voltage of 3.8 V. As is obvious from Equation 1, the common-mode and differential voltages are coupled: as the differential voltage increases in magnitude, the maximum common-mode voltage supported decreases.

Using a similar analysis, and considering the 0-V minimum input voltage, we can see that we could simultaneously support a differential voltage of 400 mV and a common-mode voltage of 0.2 V. Thus, we have a receiver that can support common-mode voltages in the approximate range of 0.2 V to 3.8 V.

Feature Description (continued)

The 400-mV example alluded to above is a reasonable maximum differential input voltage across a wide variety of standards (LVDS, M-LVDS, CML, LVPECL, and so on). We can use the specifications for any of these standards to understand the value of this wide input range receiver.

A standard compliant LVDS driver generates a 350-mV differential signal with a common-mode voltage of 1.2 V. The noninverting output thus resides at 1.375 V, while the inverting signal is at a voltage of 1.025 V. Because the SN65LVDSx10x family receiver operates over a range of 0 V to 4 V, the wide common-mode receiver then can accept signals that are common-mode shifted by -1.025 V to 2.625 V. Similar analysis can be performed for any other input signal.

10.3.1.2 Sensitivity

Table 2 provides a truth table for the SN65LVDSx10x family. Again, the same receiver circuitry is used on each of the devices in this family; therefore, the truth table is the same for all family devices. When the differential input voltage is greater than 100 mV, the receiver outputs a HI level. If the differential input voltage is less than -100 mV, the receiver outputs a LO level.

Between these two thresholds the receiver output is indeterminate. When the input signal falls in this -100 mV $< V_{ID} < 100$ mV range, the receiver output state cannot be determined unambiguously. Having said that, it is important to note that the SN65LVDSx10x family receivers include 25 mV of hysteresis. The hysteresis is incorporated into the design to prevent the output switching when the receiver input voltage is close to 0 V (for example, the receiver inputs are open-circuited, or the receiver is connected to a driver that is high-impedance). With the open-circuited input and when the magnitude of the differential noise voltage on the bus is low (approximately $< \pm 10$ mV), the hysteresis serves to hold the device output at the last known state. This feature helps prevent chattering on the device output.

Noticeably absent from this receiver is any integrated failsafe feature. External components may be added to the receiver circuit to provide failsafe. Such an implementation is covered below.

10.3.1.3 Failsafe Considerations

Failsafe, in regard to a line receiver, usually means that the output goes to a defined logical state with no input signal. To keep added jitter to an absolute minimum, the SN65LVDS100 does not include this feature. It does exhibit 25 mV of input voltage hysteresis to prevent oscillation and keep the output in the last state prior to input-signal loss (assuming the differential noise in the system is less than the hysteresis).

Should failsafe be required, it may be added externally with a 1.6-k Ω pullup resistor to the 3.3-V supply and a 1.6-k Ω pulldown resistor to ground as shown in **Figure 36**. The default output state is determined by which line is pulled up or down and is the user's choice. The location of the 1.6-k Ω resistors is not critical. However, the 100- Ω resistor should be located at the end of the transmission line.

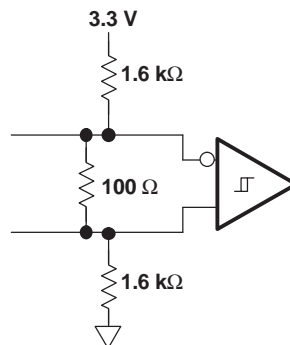

Figure 36. External Failsafe Circuit

Addition of this external failsafe will reduce the differential noise margin and add jitter to the output signal. The roughly 100-mV steady-state voltage generated across the 100- Ω resistor adds (or subtracts) from the signal generated by the upstream line driver. If the differential output of the line driver is symmetrical about zero volts, then the input at the receiver will appear asymmetrical with the external failsafe. Perhaps more important, is the extra time it takes for the input signal to overcome the added failsafe offset voltage.

Feature Description (continued)

In [Figure 37](#) and using an external failsafe, the high-level differential voltage at the input of the SN65LVDS100 reaches 340 mV and the low-level –400 mV indicating a 60-mV differential offset induced by the external failsafe circuitry. The figure also reveals that the lowest peak-to-peak time jitter does not occur at zero-volt differential (the nominal input threshold of the receiver) but at –60 mV, the failsafe offset.

The added jitter from external failsafe increases as the signal transition times are slowed by cable effects. When a ten-meter CAT-5 UTP cable is introduced between the driver and receiver, the zero-crossing peak-to-peak jitter at the receiver output adds 250 ps when the external failsafe is added with this specific test set up. If external failsafe is used in conjunction with the SN65LVDS100, the noise margin and jitter effects should be budgeted.

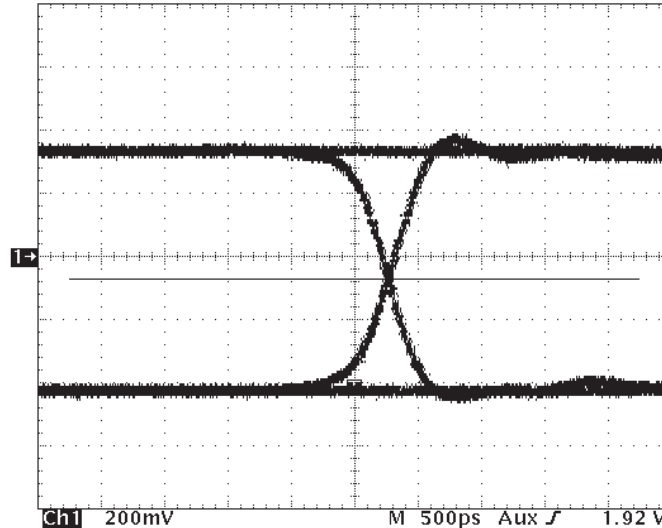

Figure 37. Receiver Input Eye Pattern with External Failsafe

10.3.1.4 V_{BB} Voltage Reference

Pin 4 (V_{BB}) on the SN65LVDS10x devices acts a voltage reference. This is an output signal from the device, with a nominal value of $V_{CC} - 1.35$ V. This output can be used when receiving a single-ended input signal. This voltage reference would then be connected to the inverting input pin on the device (pin 3: B). The application where such a use makes sense is when the device is to receive a single-ended 3.3-V LVPECL signal. The common-mode voltage of a 3.3-V LVPECL signal is approximately 1.35 V below the device supply rail. While the value of V_{BB} is ideal for single-ended LVPECL signals, its use may be extended to other single-ended inputs as long as the active single-ended signal is conditioned to have a common-mode voltage close to the nominal value of V_{BB} .

Caution is in order when using the V_{BB} signal. The expected application when using this signal is as a voltage reference to high-impedance input. The maximum current that can be sourced by this pin is 400 μ A, while the maximum current that can be sunk is 12 μ A. In cases where the SN65LVDS10x device is to be used without using V_{BB} as a reference, the V_{BB} pin should be left unconnected.

10.3.1.5 Integrated Termination

The SN65LVDT10x devices are identical to the SN65LVDS10x devices in all regards, with the addition that the SN65LVDT10x devices incorporate an integrated termination resistor along with the receiver. This termination would take the place of the matched load-line termination mentioned above. The SN65LVDT10x can be used in a point-to-point system or in a multidrop system when it is the last receiver on the multidrop bus. The SN65LVDT10x should not be used at every node in a multidrop system as this would change the loaded bus impedance throughout the bus resulting in multiple reflections and signal distortion.

10.3.1.6 Receiver Equivalent Schematic

The SN65LVDT10x equivalent input schematic diagram is shown in [Figure 38](#). The receiver input is a high-impedance differential pair in the case of the SN65LVDS10x. The SN65LVDT10x devices include an internal termination resistor of $110\ \Omega$ across the input port. 7-V Zener diodes are included on each input to provide ESD protection.

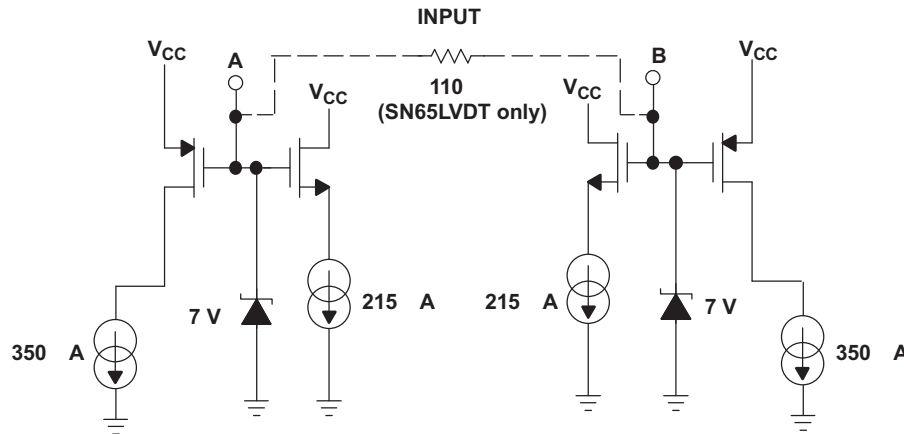

Figure 38. Receiver Equivalent Schematic

10.3.2 Driver Features

10.3.2.1 Signaling Rate, Edge Rate, and Added Jitter

The SN65LVDT10x family has been designed to provide uncompromising signal quality at signaling rates up to 2 Gbps, and beyond. Specifying a maximum signaling rate (the signaling rate is the same as the bit rate) for a device depends on the eye quality that can be achieved. This eye quality is driven by a number of factors, with two of the most critical parameters being the rise or fall time and added jitter.

The rise and fall times for a device are critical for an obvious reason: the time it takes for a device to change states will be a limiting factor in how fast a device can be operated. If a device is operated much faster than the speed at which it can change states, the vertical opening of the eye diagram will be decreased. In some cases this may be perfectly acceptable. As an example, assume an SN65LVDS100 is being used to receive a CML signal, and translate the CML signal into an LVDS signal. At speeds up to 2 Gbps (or 1 GHz for a clock signal because there are 2 bit times for each clock cycle), the LVDS output signal will have a differential output voltage of at least 247 mV, with a nominal value of 340 mV (see the [Electrical Characteristics](#) section for reference). If the input is at a higher speed, there is no circuitry within the SN65LVDS100 that would prevent the device from trying to output an LVDS signal. As the signaling rate is increased beyond 2 Gbps, the output signal would show a decrease in vertical eye opening. This decrease may not impact the utility of the device at the system level. Signal chain noise analysis would need to be performed to determine whether the overall system would be affected.

In a similar way, we can see the effect of added jitter, and how it can place upper limits on the useful operating rate. At the stated 2-Gbps signaling rate, the unit interval (UI) time, t_{UI} , is the reciprocal of 2 Gbps, or 500 ps. As added jitter is introduced by a device such as the SN65LVDT10x family, it serves to close down the eye pattern horizontally (or in time). As the output eye diagram will eventually be used to recover the transmitted or encoded data, the jitter tolerance at the eventual consumer would determine if the eye closure introduced by a SN65LVDT10x is acceptable. The nominal total jitter for the SN65LVDT10x family devices is 28 ps, while the worst case jitter is 65 ps. The 28 ps represents less than 6% of the UI and the 65 ps represents 13% of the UI. Both values will generally be within the amount of added jitter that can be tolerated in a system.

10.3.2.2 SN65LVDT100 LVDS Output

10.3.2.2.1 Driver Output Voltage

The SN65LVDT100 driver operates and meets all the specified performance requirements for supply voltages in the range of 3 V to 3.6 V. The driver output voltage has a nominal value of 340 mV, with maximum and minimum output voltages that meet the LVDS standard specifications of 247 mV and 454 mV, respectively.

10.3.2.2.2 Driver Offset

An LVDS compliant driver is required to maintain the common-mode output voltage at 1.2 V (± 75 mV). The SN65LVDS100 incorporates sense circuitry and a control loop to source common-mode current and keep the output signal within specified values. Further, the device maintains the output common-mode voltage at this set point over the full 3-V to 3.6-V supply range.

10.3.2.3 SN65LVDS101 LVPECL Output

10.3.2.3.1 Driver Voltage

The SN65LVDS101 driver is an LVPECL differential driver. Figure 40 shows an equivalent output schematic for the SN65LVDS101 driver. The differential signal output of the driver is simply the output of the differential pair, emitter-coupled to the device output. For an ECL class device such as this, the output base-emitter diodes must always be on. This need for the consistently active output stages helps explain the classical ECL load shown in Figure 39.

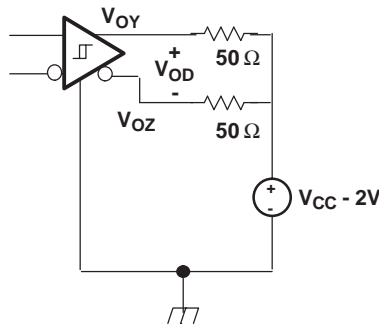
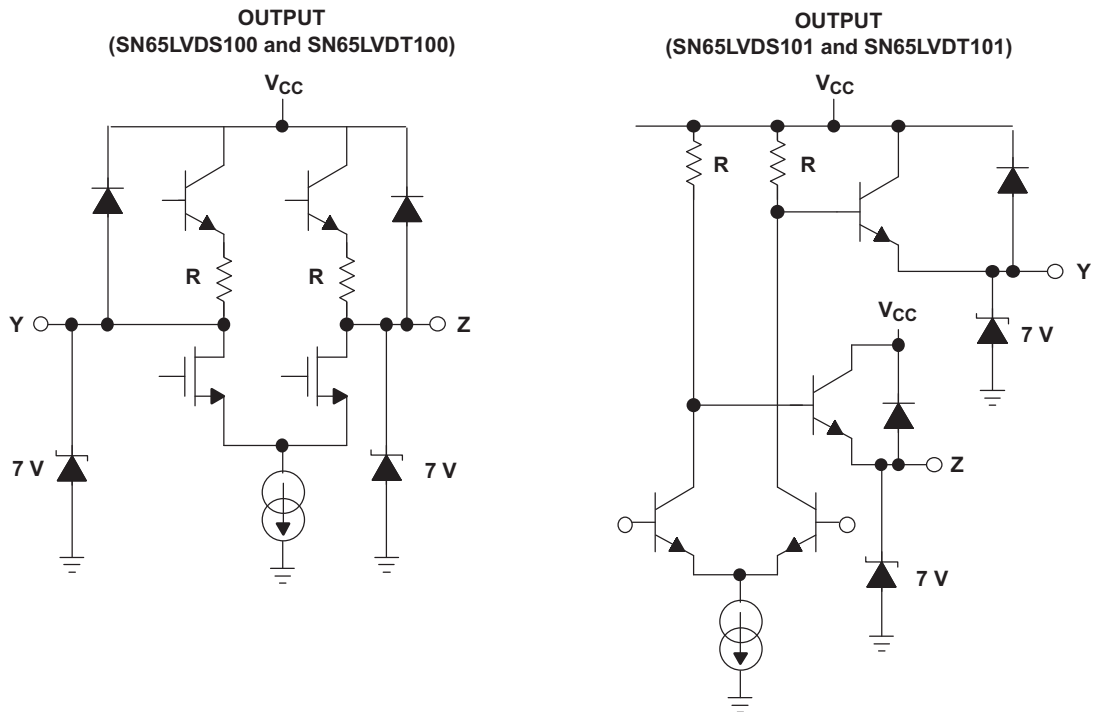

Figure 39. Typical Termination for LVPECL Output Driver (SN65LVDS101)

Figure 39 shows that the SN65LVDS101 outputs drive 50- Ω loads terminated to a supply that is 2 V below the supply voltage of the SN65LVDS101 device. Driving a load that is referenced to a supply 2 V below the device supply assures that the final transistor stages in the output driver are always on. A common question for those new to ECL devices concerns the implementation of this output load. There is no need generally to have a regulated supply to support this. A Thevenin load is often used to create a 50- Ω effective termination, at a common-mode voltage 2 V below the local supply rail. Many other implementations have been used. The key to the specific load that is implemented lies in the understanding that the ECL driver output stage is a voltage driver, with the output voltage always referenced to the positive power rail for the device. The load that is driven must ensure that the final transistors on each output leg are in the active regions at all times.

10.3.2.4 Driver Equivalent Schematics

The SN65LVDS10x equivalent output schematic diagrams are shown in Figure 40. The SN65LVDS10x output is represented by a differential pair with 7-V Zener diodes on each output leg. The Zener diodes provide ESD protection. The SN65LVDS10x1 LVPECL output is represented by a differential pair, with follower stages, and with 7-V Zener diodes on each output leg for ESD protection.

Figure 40. Driver Equivalent Schematics

10.4 Device Functional Modes

Table 2. SN65LVDS100 Truth Table

DIFFERENTIAL INPUT	OUTPUTS ⁽¹⁾	
$V_{ID} = V_A - V_B$	Y	Z
$V_{ID} \geq 100 \text{ mV}$	H	L
$-100 \text{ mV} < V_{ID} < 100 \text{ mV}$?	?
$V_{ID} \leq -100 \text{ mV}$	L	H
Open	?	?

(1) H = high level, L = low level, ? = indeterminate

11 Application and Implementation

NOTE

Information in the following applications sections is not part of the TI component specification, and TI does not warrant its accuracy or completeness. TI's customers are responsible for determining suitability of components for their purposes. Customers should validate and test their design implementation to confirm system functionality.

11.1 Application Information

The SN65LV Dx10x are single-channel repeaters/translators. The functionality of these devices is simple, yet extremely flexible, leading to their use in designs ranging from wireless base stations to desktop computers. SN65LV Dx10x devices are often used as buffers to regenerate or repeat the signal at their port. The devices in this family can accept any differential signal that meets the input port requirements specified herein. The input signal does not need to comply with any particular standard to be repeated: it just needs to fall within the common-mode input range of these devices, and have a differential input signal of at least 100 mV in magnitude. With such an input the designer can use a SN65LV Dx100 device to repeat the digital input signal, and generate an output signal that carries the information at its input port, and complies with all the requirements of the LVDS standard. Similarly, an SN65LV Dx101 device is a general-purpose differential receiver that repeats the input data at its output port, while complying with LVPECL output specifications.

Translating from one signaling standard to a different signaling standard is a common application issue. Two ICs that use different signaling standards may need to communicate with each other. An FPGA may output an LVDS signal and an ASIC may be designed to receive LVPECL inputs. Directly connecting the two devices would end up with communication errors. In such a case an SN65LV DS101 can be used to translate between the incompatible standards. The common application issue of converting from one standard to another are covered in [Typical Application](#).

11.2 Typical Application

11.2.1 PECL to LVDS Translation

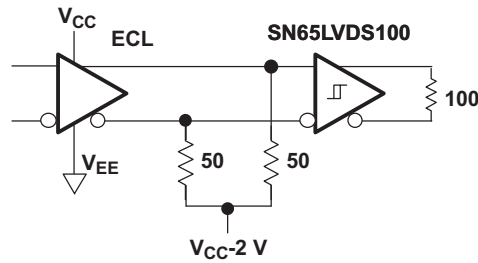

Figure 41. PECL to LVDS Translation

11.2.1.1 Design Requirements

DESIGN PARAMETER	EXAMPLE VALUE
PECL Source Supply Voltage (V_{CC})	3.3 V
SN65LVDS100 Supply Voltage	3.0 to 3.6 V
Driver Signaling Rate	DC to 2000 Mbps
Interconnect Characteristic Impedance	100 Ω
Termination Resistance	50 Ω to $V_{CC} - 2$ V on each side of transmission line

11.2.1.2 Detailed Design Requirements

Translating an LVPECL signal to LVDS is straightforward using the SN65LVDS100. The common-mode output of an LVPECL driver is approximately 2 V, while the differential output voltage would be approximately 600 to 800 mV. 2 V is right in the middle of the common-mode range of the SN65LVDS100, while the differential voltage is more than enough signal for the high-sensitivity receiver. As shown in [Figure 41](#), 50- Ω pulldown resistors to $V_{CC} - 2$ V are needed, and the rationale for these have been discussed earlier.

11.2.1.3 Application Curve

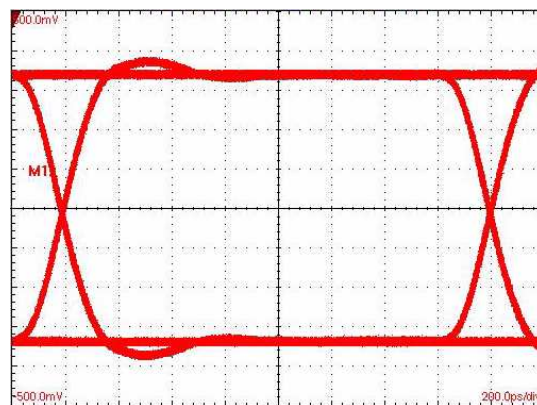

Horizontal Scale= 200 ps/div

LVPECL-to-LVDS

Figure 42. SN65LVDS100 Mbps, $2^{23} - 1$ PRBS

11.2.2 LVDS to 3.3-V PECL Translation

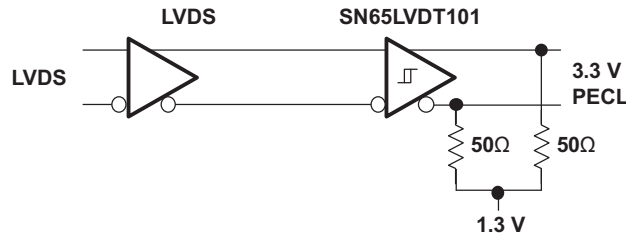

Figure 43. LVDS to 3.3-V PECL Translation

11.2.2.1 Design Requirements

DESIGN PARAMETER	EXAMPLE VALUE
LVDS Source Supply Voltage (V_{CC})	3.3 V
SN65LVDT101 Supply Voltage	3.0 to 3.6 V
Driver Signaling Rate	DC to 2000 Mbps
Interconnect Characteristic Impedance	100 Ω
Termination Resistance	Integrated in SN65LVDT101

11.2.2.2 Detailed Design Requirements

Translating an LVDS signal to LVPECL is conveniently done using the SN65LVDT101. The common-mode output of an LVDS driver is 1.2 V, while the differential output voltage would be approximately 350 mV. 1.2 V is well within the common-mode range of the SN65LVDT101, while the differential voltage is more than enough signal for the high-sensitivity receiver. The integrated variant of the LVPECL translators is used here as it includes precisely the load required for operation of an LVDS driver. This circuit is shown in [Figure 43](#).

11.2.2.3 Application Curve

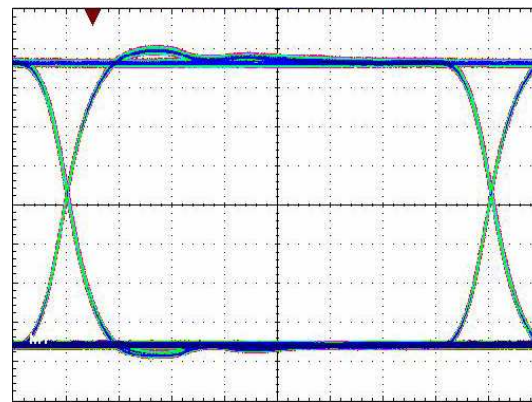

Horizontal Scale= 200 ps/div

LVDS-to-LVPECL

Figure 44. SN65LVDS101 Mbps, $2^{23} - 1$ PRBS

11.2.3 5-V PECL to 3.3-V PECL Translation

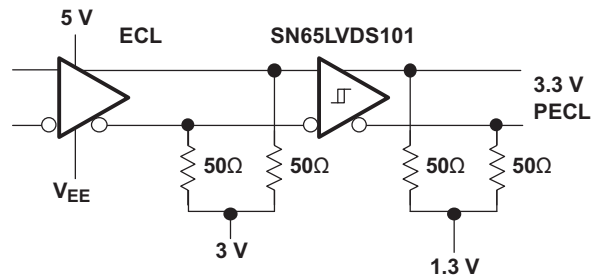

Figure 45. 5-V PECL to 3.3-V PECL Translation

11.2.3.1 Design Requirements

DESIGN PARAMETER	EXAMPLE VALUE
PECL Source Supply Voltage (V_{CC})	5.0 V
SN65LVDS101 Supply Voltage	3.0 to 3.6 V
Driver Signaling Rate	DC to 2000 Mbps
Interconnect Characteristic Impedance	100 Ω
Termination Resistance	50 Ω to $V_{CC} - 2$ V on each side of transmission line

11.2.3.2 Detailed Design Requirements

At times a 5-V PECL will need to be converted to a 3.3-V PECL signal. When the 5-V signal is encoded (8b10b for example), ac-coupling can be used. [Figure 45](#) shows how to translate a 5-V PECL signal to 3.3-V PECL when a dc connection is needed.

The 50- Ω pulldown resistors to $V_{CC} - 2$ V are familiar by now. The SN65LVDS101 provides the 3.3-V based LVPECL signal.

A level of care must be exercised with this solution. The absolute voltage levels at the input pins to the SN65LVDS101 must be less than or equal to 4 V. With a 5-V PECL signal, the non-inverting output will generally be just below 4 V. If the 5-V PECL supply goes much above 5 V, the input voltage at the SN65LVDS101 may violate the specifications. Ensure that the worst-case high-output voltage from the 5-V PECL driver will be within the range of the SN65LVDS101.

11.2.3.3 Application Curve

Reference: [Figure 44](#)

11.2.4 CML to LVDS or 3.3-V PECL Translation

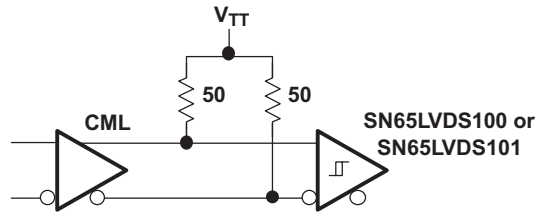

Figure 46. CML to LVDS or 3.3-V PECL Translation

11.2.4.1 Design Requirements

DESIGN PARAMETER	EXAMPLE VALUE
CML Termination Supply Voltage (V_{TT})	3.3 V
SN65LVDS10x Supply Voltage	3.0 to 3.6 V
Driver Signaling Rate	DC to 2000 Mbps
Interconnect Characteristic Impedance	100 Ω
Termination Resistance	50 Ω to V_{TT} on each side of transmission line

11.2.4.2 Detailed Design Requirements

Current-mode logic (CML) signals are designed to drive a 100- Ω transmission line with a load termination being two 50- Ω pullup resistors to a power supply. This circuit is shown in Figure 46. Common CML drivers include 16-mA current sources that serve to develop the differential output signal. Using this 16-mA current source and assuming a 3.3-V CML driver is being used, the common-mode output of the driver in Figure 46 is 2.9 V and the differential output voltage is 800 mV. Both values are well within the operational envelope of the SN65LVDx10x family receivers.

To convert from 3.3-V CML signals to LVDS signals, the driver and receiver are connected in a straightforward fashion. The SN65LVDS100 is used in this circuit to convert to an LVDS output, while the SN65LVDS101 is used to convert to LVPECL.

Again, the reader will notice that the integrated termination devices in the SN65LVDx10x family are not mentioned for this conversion. The 'LVDT devices incorporate a shunt 100- Ω termination which are not appropriate when a pullup termination is needed.

11.2.4.3 Application Curve

Reference: [Figure 44](#)

11.2.5 Single-Ended 3.3-V PECL to LVDS Translation

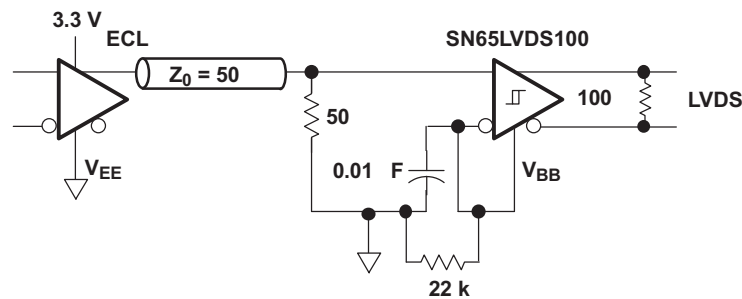

Figure 47. Single-Ended 3.3-V PECL to LVDS Translation

11.2.5.1 Design Requirements

DESIGN PARAMETER	EXAMPLE VALUE
ECL Supply Voltage	3.3 V
SN65LVDS100 Supply Voltage	3.0 to 3.6 V
Driver Signaling Rate	DC to 2000 Mbps
Interconnect Characteristic Impedance	50 Ω
Termination Resistance	50 Ω to GND
V_{BB} Current to GND	91 μ A

11.2.5.2 Detailed Design Requirements

The SN65LVDS100 family of devices provides the flexibility to translate single-ended input signals to differential outputs. The output can be either LVDS or LVPECL, depending on the choice of SN65LVDS10x that is used. [Figure 47](#) demonstrates how to convert a single-ended LVPECL signal to an LVDS signal.

The common receiver used in this family will work with any pair of input signals that comply with its input requirements. In this example, let's assume the single-sided LVPECL signal has a high-level voltage of $V_{CC} - 1$ V = 2.3 V. Assume the low-level output voltage is $V_{CC} - 1.6$ V = 1.7 V. The common-mode of these two levels is 2 V, which happens to be $V_{CC} - 1.3$ V.

To use a single-ended signal with these receivers, we need to bias the unused input of the differential receiver. In this case we will bias the inverting input pin. With the high and low signal levels calculated above, we see the optimum bias point for the unused pin would be the common-mode or average signal level. The V_{BB} pin provides this needed voltage. V_{BB} has a nominal value of $V_{CC} - 1.35$ V.

The 22-k Ω resistor in the circuit serves to limit the dc current being sourced by V_{BB} . This resistor setting will limit the current to less than 100 μ A, well within the recommended maximum value of 400 μ A.

The drawback of a single-ended to differential-converted shown here is that the unused pin is being set to a fixed value that will be close to the signal common-mode voltage. Any deviation from V_{BB} (in the actual signal common-mode) results in duty-cycle distortion at the differential output. Whether or not this is an issue is application dependent. If, for example, the input signal is a clock signal and clocking only happens on one edge, the distortion may be acceptable.

11.2.5.3 Application Curve

Reference: [Figure 42](#)

11.2.6 Single-Ended CMOS to LVDS Translation

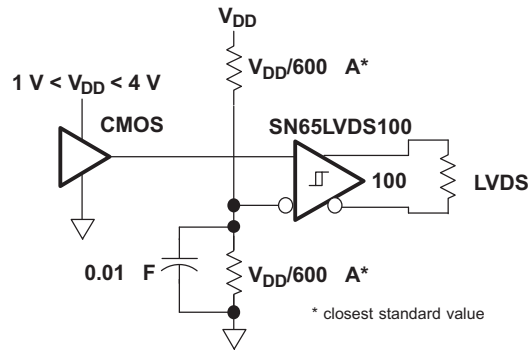

Figure 48. Single-Ended CMOS to LVDS Translation

11.2.6.1 Design Requirements

DESIGN PARAMETER	EXAMPLE VALUE
CMOS Supply Voltage (V_{DD})	$1\text{ V} < V_{DD} < 4\text{ V}$
SN65LVDS100 Supply Voltage	3.0 to 3.6 V
Driver Signaling Rate	DC to 500 Mbps
V_{BB} Current to GND	91 μA ($V_{DD} = 4\text{ V}$)

11.2.6.2 Detailed Design Requirements

The SN65LVDx10x family of devices can also translate a CMOS input signals to differential outputs. The output can be either LVDS or LVPECL, depending on the choice of SN65LVDS10x that is used. Figure 48 demonstrates how to convert a CMOS signal to an LVDS signal.

The CMOS signal in this case can be from any power rail up to 4 V (not a common rail, but the maximum allowable input at the receiver nonetheless). The unused or inverting signal in this case is biased to $V_{DD}/2$ which will be equal to the common-mode of the CMOS input signal.

There is less concern with this circuit with regards to duty-cycle distortion, as we have assumed that the CMOS driver and the local voltage divider are referenced to the same rail. If different rails were used, the usual cautions on duty-cycle distortion would apply.

11.2.6.3 Application Curve

Reference: [Figure 42](#)

11.2.7 Single-Ended CMOS to 3.3-V PECL Translation

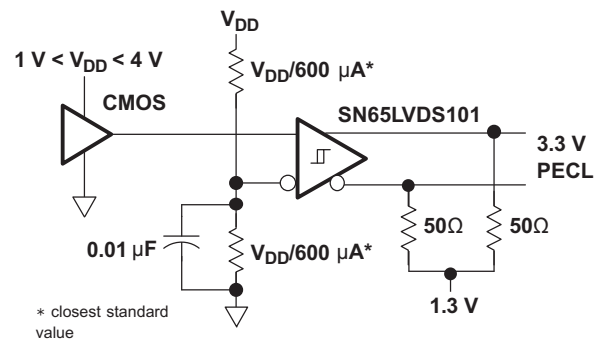

Figure 49. Single-Ended CMOS to 3.3-V PECL Translation

11.2.7.1 Design Requirements

DESIGN PARAMETER	EXAMPLE VALUE
CMOS Supply Voltage (V_{DD})	$1\text{ V} < V_{DD} < 4\text{ V}$
SN65LVDS101 Supply Voltage	3.0 to 3.6 V
Driver Signaling Rate	DC to 500 Mbps
V_{BB} Current to GND	$91\ \mu\text{A}$ ($V_{DD} = 4\text{ V}$)

11.2.7.2 Detailed Design Requirements

Figure 49 demonstrates how to implement a CMOS to LVPECL translation. The elements in this circuit are now familiar, so the reader is referred to the previous discussions.

11.2.7.3 Application Curve

Reference: [Figure 44](#)

11.2.8 Receipt of AC-Coupled Signals

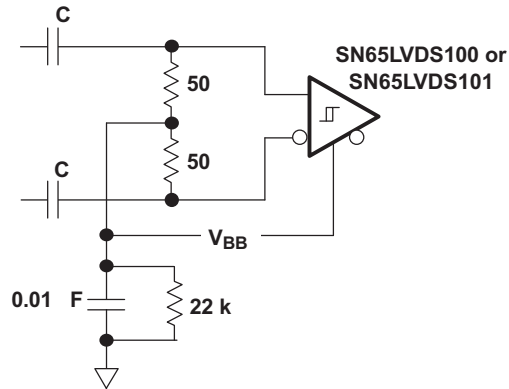

Figure 50. Receipt of AC-Coupled Signals

11.2.8.1 Design Requirements

DESIGN PARAMETER	EXAMPLE VALUE
AC-coupling capacitor	10 nF
SN65LVDS100 Supply Voltage	3.0 to 3.6 V
Driver Signaling Rate	Up to 500 Mbps
V_{BB} Current to GND	91 μ A ($V_{DD} = 4$ V)
Low-Frequency Cutoff of RC Filter	318 kHz

11.2.8.2 Detailed Design Requirements

The general need to convert ac-coupled signals to either LVDS or LVPECL is shown in Figure 50. The transmission line is terminated with a center-tapped 100- Ω resistor network. The center tap is tied to the previously discussed V_{BB} bias reference. The bias reference is current limited with the same 22-k Ω resistor to ground. The use of V_{BB} is chosen for ease. This sets the common-mode at the receiver input approximately in the middle of the receiver input range (approximately 2 V).

The ac-coupling capacitors used on the input signal may be integrated into the source destination device, or may be discretely inserted on board. The capacitance value and the 50- Ω to ground terminations serve as a high-pass filter, blocking dc content. With a 10-nF capacitor the low-frequency zero is at 318 kHz. The reader needs to understand the frequency content of the incoming signal to determine whether this zero location is appropriate.

11.2.8.3 Application Curve

Reference: [Figure 42](#)

12 Power Supply Recommendations

The LVDS drivers in this data sheet are designed to operate from a single power supply, with supply voltages in the range of 3.0 V to 3.6 V. In a typical application, a driver and a receiver may be on separate boards, or even separate equipment. In these cases, separate supplies would be used at each location. The expected ground potential difference between the driver power supply and the receiver power supply would be less than $|\pm 1 \text{ V}|$. Board level and local device level bypass capacitance should be used and have been covered.

13 Layout

13.1 Layout Guidelines

13.1.1 Microstrip vs. Stripline Topologies

As per [SLLD009](#), modern printed-circuit boards usually offer designers two transmission line options: Microstrip and stripline. Microstrips are traces on the outer layer of a PCB, as shown in [Figure 51](#).

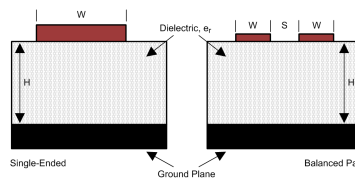

Figure 51. Microstrip Topology

On the other hand, striplines are traces between two ground planes. Striplines are less prone to emissions and susceptibility problems since the reference planes effectively shield the embedded traces. However, from the standpoint of high-speed transmission, juxtaposing two planes creates additional capacitance. TI recommends routing LVDS signals on microstrip transmission lines, if possible. The PCB traces allow designers to specify the necessary tolerances for Z_0 based on the overall noise budget and reflection allowances. Footnotes 1, 2, and 3 provide formulas for Z_0 and t_{PD} for differential and single-ended traces. ⁽¹⁾ ⁽²⁾ ⁽³⁾

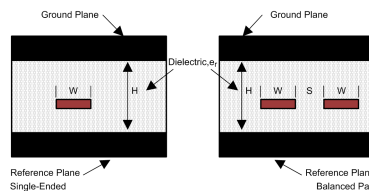

Figure 52. Stripline Topology

13.1.2 Dielectric Type and Board Construction

The speeds at which signals travel across the board dictates the choice of dielectric. FR-4, or equivalent, usually provides adequate performance for use with LVDS signals. If rise or fall times of TTL/CMOS signals are less than 500 ps, empirical results indicate that a material with a dielectric constant near 3.4, such as Rogers™ 4350 or Nelco N4000-13 is better suited. Once the designer chooses the dielectric, there are several parameters pertaining to the board construction that can affect performance. The following set of guidelines were developed experimentally through several designs involving LVDS devices:

- Copper weight: 15 g or 1/2 oz start, plated to 30 g or 1 oz
- All exposed circuitry should be solder-plated (60/40) to 7.62 μm or 0.0003 in (minimum).
- Copper plating should be 25.4 μm or 0.001 in (minimum) in plated-through-holes.
- Solder mask over bare copper with solder hot-air leveling

(1) Howard Johnson & Martin Graham. 1993. High Speed Digital Design – A Handbook of Black Magic. Prentice Hall PRT. ISBN number 013395724.

(2) Mark I. Montrose. 1996. Printed Circuit Board Design Techniques for EMC Compliance. IEEE Press. ISBN number 0780311310.

(3) Clyde F. Coombs, Jr. Ed, Printed Circuits Handbook, McGraw Hill, ISBN number 0070127549.

Layout Guidelines (continued)

13.1.3 Recommended Stack Layout

Following the choice of dielectrics and design specifications, you must decide how many levels to use in the stack. To reduce the TTL/CMOS-to-LVDS crosstalk, it is a good practice to have at least two separate signal planes as shown in [Figure 53](#).

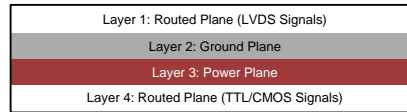

Figure 53. Four-Layer PCB Board

NOTE

The separation between layers 2 and 3 should be 127 μm (0.005 in). By keeping the power and ground planes tightly coupled, the increased capacitance acts as a bypass for transients.

One of the most common stack configurations is the six-layer board, as shown in [Figure 54](#).

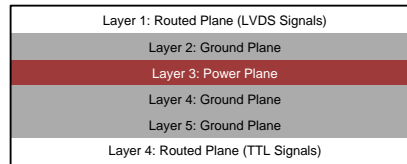

Figure 54. Six-Layer PCB Board

In this particular configuration, it is possible to isolate each signal layer from the power plane by at least one ground plane. The result is improved signal integrity; however, fabrication is more expensive. Using the 6-layer board is preferable, since it offers the layout designer more flexibility in varying the distance between signal layers and referenced planes, in addition to ensuring reference to a ground plane for signal layers 1 and 6.

13.1.4 Separation Between Traces

The separation between traces depends on several factors; however, the amount of coupling that can be tolerated usually dictates the actual separation. Low-noise coupling requires close coupling between the differential pair of an LVDS link to benefit from the electromagnetic field cancellation. The traces should be 100- Ω differential and thus coupled in the manner that best fits this requirement. In addition, differential pairs should have the same electrical length to ensure that they are balanced, thus minimizing problems with skew and signal reflection.

In the case of two adjacent single-ended traces, one should use the 3-W rule, which stipulates that the distance between two traces must be greater than two times the width of a single trace, or three times its width measured from trace center to trace center. This increased separation effectively reduces the potential for crosstalk. The same rule should be applied to the separation between adjacent LVDS differential pairs, whether the traces are edge-coupled or broadside-coupled.

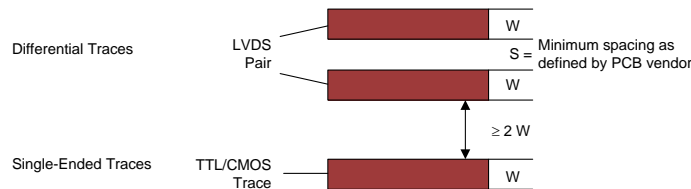

Figure 55. 3-W Rule for Single-Ended and Differential Traces (Top View)

Layout Guidelines (continued)

You should exercise caution when using autorouters, because they do not always account for all factors affecting crosstalk and signal reflection. For instance, it is best to avoid sharp 90° turns to prevent discontinuities in the signal path. Using successive 45° turns tends to minimize reflections.

13.1.5 Crosstalk and Ground Bounce Minimization

To reduce crosstalk, it is important to provide a return path for high-frequency currents that is as close as possible to its originating trace. A ground plane usually achieves this. Because the returning currents always choose the path of lowest inductance, they are most likely to return directly under the original trace, thus minimizing crosstalk. Lowering the area of the current loop lowers the potential for crosstalk. Traces kept as short as possible with an uninterrupted ground plane running beneath them emit the minimum amount of electromagnetic field strength. Discontinuities in the ground plane increase the return path inductance and should be avoided.

13.2 Layout Example

See [Layout Guidelines](#) examples.

At least two or three times the width of an individual trace should separate single-ended traces and differential pairs to minimize the potential for crosstalk. Single-ended traces that run in parallel for less than the wavelength of the rise or fall times usually have negligible crosstalk. Increase the spacing between signal paths for long parallel runs to reduce crosstalk. Boards with limited real estate can benefit from the staggered trace layout, as shown in [Figure 56](#).

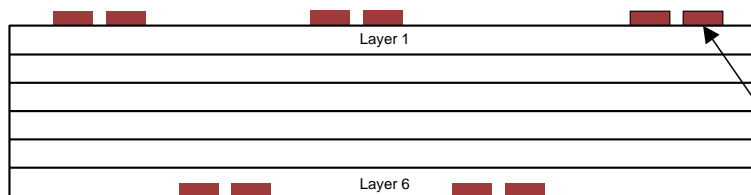

Figure 56. Staggered Trace Layout

This configuration lays out alternating signal traces on different layers; thus, the horizontal separation between traces can be less than 2 or 3 times the width of individual traces. To ensure continuity in the ground signal path, TI recommends having an adjacent ground via for every signal via, as shown in [Figure 57](#). Note that vias create additional capacitance. For example, a typical via has a lumped capacitance effect of 1/2 pF to 1 pF in FR4.

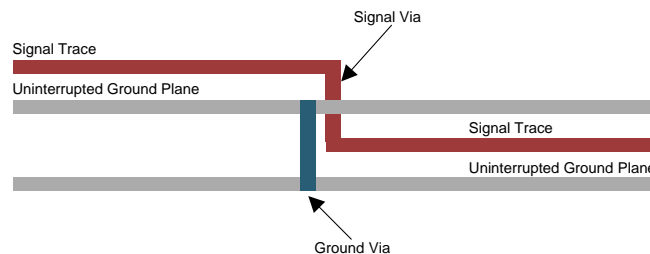

Figure 57. Ground Via Location (Side View)

Short and low-impedance connection of the device's ground pins to the PCB ground plane reduces ground bounce. Holes and cutouts in the ground planes can adversely affect current return paths if they create discontinuities that increase returning current loop areas.

To minimize EMI problems, TI recommends avoiding discontinuities below a trace (for example, holes, slits, and so on) and keeping traces as short as possible. Zoning the board wisely by placing all similar functions in the same area, as opposed to mixing them together, helps reduce susceptibility issues.

14 Device and Documentation Support

14.1 Related Links

The table below lists quick access links. Categories include technical documents, support and community resources, tools and software, and quick access to sample or buy.

Table 3. Related Links

PARTS	PRODUCT FOLDER	SAMPLE & BUY	TECHNICAL DOCUMENTS	TOOLS & SOFTWARE	SUPPORT & COMMUNITY
SN65LVDS100	Click here	Click here	Click here	Click here	Click here
SN65LVDT100	Click here	Click here	Click here	Click here	Click here
SN65LVDS101	Click here	Click here	Click here	Click here	Click here
SN65LVDT101	Click here	Click here	Click here	Click here	Click here

14.2 Community Resources

The following links connect to TI community resources. Linked contents are provided "AS IS" by the respective contributors. They do not constitute TI specifications and do not necessarily reflect TI's views; see TI's [Terms of Use](#).

TI E2E™ Online Community *TI's Engineer-to-Engineer (E2E) Community*. Created to foster collaboration among engineers. At e2e.ti.com, you can ask questions, share knowledge, explore ideas and help solve problems with fellow engineers.

Design Support *TI's Design Support* Quickly find helpful E2E forums along with design support tools and contact information for technical support.

14.3 Trademarks

E2E is a trademark of Texas Instruments.
 Rogers is a trademark of Rogers Corporation.
 All other trademarks are the property of their respective owners.

14.4 Electrostatic Discharge Caution



These devices have limited built-in ESD protection. The leads should be shorted together or the device placed in conductive foam during storage or handling to prevent electrostatic damage to the MOS gates.

14.5 Glossary

[SLYZ022](#) — *TI Glossary*.

This glossary lists and explains terms, acronyms, and definitions.

15 Mechanical, Packaging, and Orderable Information

The following pages include mechanical, packaging, and orderable information. This information is the most current data available for the designated devices. This data is subject to change without notice and revision of this document. For browser-based versions of this data sheet, refer to the left-hand navigation.

PACKAGING INFORMATION

Orderable Device	Status (1)	Package Type	Package Drawing	Pins	Package Qty	Eco Plan (2)	Lead/Ball Finish (6)	MSL Peak Temp (3)	Op Temp (°C)	Device Marking (4/5)	Samples
SN65LVDS100D	ACTIVE	SOIC	D	8	75	Green (RoHS & no Sb/Br)	CU NIPDAU	Level-1-260C-UNLIM	-40 to 85	DL100	Samples
SN65LVDS100DG4	ACTIVE	SOIC	D	8	75	Green (RoHS & no Sb/Br)	CU NIPDAU	Level-1-260C-UNLIM	-40 to 85	DL100	Samples
SN65LVDS100DGK	ACTIVE	VSSOP	DGK	8	80	Green (RoHS & no Sb/Br)	CU NIPDAU	Level-1-260C-UNLIM	-40 to 85	AZK	Samples
SN65LVDS100DGKG4	ACTIVE	VSSOP	DGK	8	80	Green (RoHS & no Sb/Br)	CU NIPDAU	Level-1-260C-UNLIM	-40 to 85	AZK	Samples
SN65LVDS100DGKR	ACTIVE	VSSOP	DGK	8	2500	Green (RoHS & no Sb/Br)	CU NIPDAU CU NIPDAUAG	Level-1-260C-UNLIM	-40 to 85	AZK	Samples
SN65LVDS100DR	ACTIVE	SOIC	D	8	2500	Green (RoHS & no Sb/Br)	CU NIPDAU	Level-1-260C-UNLIM	-40 to 85	DL100	Samples
SN65LVDS100DRG4	ACTIVE	SOIC	D	8	2500	Green (RoHS & no Sb/Br)	CU NIPDAU	Level-1-260C-UNLIM	-40 to 85	DL100	Samples
SN65LVDS101D	ACTIVE	SOIC	D	8	75	Green (RoHS & no Sb/Br)	CU NIPDAU	Level-1-260C-UNLIM	-40 to 85	DL101	Samples
SN65LVDS101DGK	ACTIVE	VSSOP	DGK	8	80	Green (RoHS & no Sb/Br)	CU NIPDAU	Level-1-260C-UNLIM	-40 to 85	AZM	Samples
SN65LVDS101DGKR	ACTIVE	VSSOP	DGK	8	2500	Green (RoHS & no Sb/Br)	CU NIPDAU	Level-1-260C-UNLIM	-40 to 85	AZM	Samples
SN65LVDS101DGKRG4	ACTIVE	VSSOP	DGK	8	2500	Green (RoHS & no Sb/Br)	CU NIPDAU	Level-1-260C-UNLIM	-40 to 85	AZM	Samples
SN65LVDS101DR	ACTIVE	SOIC	D	8	2500	Green (RoHS & no Sb/Br)	CU NIPDAU	Level-1-260C-UNLIM	-40 to 85	DL101	Samples
SN65LVDT100D	ACTIVE	SOIC	D	8	75	Green (RoHS & no Sb/Br)	CU NIPDAU	Level-1-260C-UNLIM	-40 to 85	DE100	Samples
SN65LVDT100DGK	ACTIVE	VSSOP	DGK	8	80	Green (RoHS & no Sb/Br)	CU NIPDAU	Level-1-260C-UNLIM	-40 to 85	AZL	Samples
SN65LVDT100DGKG4	ACTIVE	VSSOP	DGK	8	80	Green (RoHS & no Sb/Br)	CU NIPDAU	Level-1-260C-UNLIM	-40 to 85	AZL	Samples
SN65LVDT100DGKR	ACTIVE	VSSOP	DGK	8	2500	Green (RoHS & no Sb/Br)	CU NIPDAU	Level-1-260C-UNLIM	-40 to 85	AZL	Samples
SN65LVDT100DGKRG4	ACTIVE	VSSOP	DGK	8	2500	Green (RoHS & no Sb/Br)	CU NIPDAU	Level-1-260C-UNLIM	-40 to 85	AZL	Samples

Orderable Device	Status (1)	Package Type	Package Drawing	Pins	Package Qty	Eco Plan (2)	Lead/Ball Finish (6)	MSL Peak Temp (3)	Op Temp (°C)	Device Marking (4/5)	Samples
SN65LVDT100DR	ACTIVE	SOIC	D	8	2500	Green (RoHS & no Sb/Br)	CU NIPDAU	Level-1-260C-UNLIM	-40 to 85	DE100	Samples
SN65LVDT101D	ACTIVE	SOIC	D	8	75	Green (RoHS & no Sb/Br)	CU NIPDAU	Level-1-260C-UNLIM	-40 to 85	DE101	Samples
SN65LVDT101DG4	ACTIVE	SOIC	D	8	75	Green (RoHS & no Sb/Br)	CU NIPDAU	Level-1-260C-UNLIM	-40 to 85	DE101	Samples
SN65LVDT101DGK	ACTIVE	VSSOP	DGK	8	80	Green (RoHS & no Sb/Br)	CU NIPDAU	Level-1-260C-UNLIM	-40 to 85	BAF	Samples
SN65LVDT101DGKR	ACTIVE	VSSOP	DGK	8	2500	Green (RoHS & no Sb/Br)	CU NIPDAU	Level-1-260C-UNLIM	-40 to 85	BAF	Samples
SN65LVDT101DR	ACTIVE	SOIC	D	8	2500	Green (RoHS & no Sb/Br)	CU NIPDAU	Level-1-260C-UNLIM	-40 to 85	DE101	Samples

(1) The marketing status values are defined as follows:

ACTIVE: Product device recommended for new designs.

LIFEBUY: TI has announced that the device will be discontinued, and a lifetime-buy period is in effect.

NRND: Not recommended for new designs. Device is in production to support existing customers, but TI does not recommend using this part in a new design.

PREVIEW: Device has been announced but is not in production. Samples may or may not be available.

OBSOLETE: TI has discontinued the production of the device.

(2) **RoHS:** TI defines "RoHS" to mean semiconductor products that are compliant with the current EU RoHS requirements for all 10 RoHS substances, including the requirement that RoHS substance do not exceed 0.1% by weight in homogeneous materials. Where designed to be soldered at high temperatures, "RoHS" products are suitable for use in specified lead-free processes. TI may reference these types of products as "Pb-Free".

RoHS Exempt: TI defines "RoHS Exempt" to mean products that contain lead but are compliant with EU RoHS pursuant to a specific EU RoHS exemption.

Green: TI defines "Green" to mean the content of Chlorine (Cl) and Bromine (Br) based flame retardants meet JS709B low halogen requirements of <=1000ppm threshold. Antimony trioxide based flame retardants must also meet the <=1000ppm threshold requirement.

(3) MSL, Peak Temp. - The Moisture Sensitivity Level rating according to the JEDEC industry standard classifications, and peak solder temperature.

(4) There may be additional marking, which relates to the logo, the lot trace code information, or the environmental category on the device.

(5) Multiple Device Markings will be inside parentheses. Only one Device Marking contained in parentheses and separated by a "~" will appear on a device. If a line is indented then it is a continuation of the previous line and the two combined represent the entire Device Marking for that device.

(6) Lead/Ball Finish - Orderable Devices may have multiple material finish options. Finish options are separated by a vertical ruled line. Lead/Ball Finish values may wrap to two lines if the finish value exceeds the maximum column width.

Important Information and Disclaimer: The information provided on this page represents TI's knowledge and belief as of the date that it is provided. TI bases its knowledge and belief on information provided by third parties, and makes no representation or warranty as to the accuracy of such information. Efforts are underway to better integrate information from third parties. TI has taken and continues to take reasonable steps to provide representative and accurate information but may not have conducted destructive testing or chemical analysis on incoming materials and chemicals. TI and TI suppliers consider certain information to be proprietary, and thus CAS numbers and other limited information may not be available for release.

In no event shall TI's liability arising out of such information exceed the total purchase price of the TI part(s) at issue in this document sold by TI to Customer on an annual basis.

TAPE AND REEL INFORMATION

QUADRANT ASSIGNMENTS FOR PIN 1 ORIENTATION IN TAPE

*All dimensions are nominal

Device	Package Type	Package Drawing	Pins	SPQ	Reel Diameter (mm)	Reel Width W1 (mm)	A0 (mm)	B0 (mm)	K0 (mm)	P1 (mm)	W (mm)	Pin1 Quadrant
SN65LVDS100DGKR	VSSOP	DGK	8	2500	330.0	12.4	5.3	3.4	1.4	8.0	12.0	Q1
SN65LVDS100DR	SOIC	D	8	2500	330.0	12.4	6.4	5.2	2.1	8.0	12.0	Q1
SN65LVDS101DGKR	VSSOP	DGK	8	2500	330.0	12.4	5.3	3.4	1.4	8.0	12.0	Q1
SN65LVDS101DR	SOIC	D	8	2500	330.0	12.4	6.4	5.2	2.1	8.0	12.0	Q1
SN65LVDT100DGKR	VSSOP	DGK	8	2500	330.0	12.4	5.3	3.4	1.4	8.0	12.0	Q1
SN65LVDT100DR	SOIC	D	8	2500	330.0	12.4	6.4	5.2	2.1	8.0	12.0	Q1
SN65LVDT101DGKR	VSSOP	DGK	8	2500	330.0	12.4	5.3	3.4	1.4	8.0	12.0	Q1
SN65LVDT101DR	SOIC	D	8	2500	330.0	12.4	6.4	5.2	2.1	8.0	12.0	Q1

TAPE AND REEL BOX DIMENSIONS

*All dimensions are nominal

Device	Package Type	Package Drawing	Pins	SPQ	Length (mm)	Width (mm)	Height (mm)
SN65LVDS100DGKR	VSSOP	DGK	8	2500	358.0	335.0	35.0
SN65LVDS100DR	SOIC	D	8	2500	350.0	350.0	43.0
SN65LVDS101DGKR	VSSOP	DGK	8	2500	358.0	335.0	35.0
SN65LVDS101DR	SOIC	D	8	2500	350.0	350.0	43.0
SN65LVDT100DGKR	VSSOP	DGK	8	2500	358.0	335.0	35.0
SN65LVDT100DR	SOIC	D	8	2500	350.0	350.0	43.0
SN65LVDT101DGKR	VSSOP	DGK	8	2500	358.0	335.0	35.0
SN65LVDT101DR	SOIC	D	8	2500	350.0	350.0	43.0



D0008A

PACKAGE OUTLINE

SOIC - 1.75 mm max height

SMALL OUTLINE INTEGRATED CIRCUIT



4214825/C 02/2019

NOTES:

- Linear dimensions are in inches [millimeters]. Dimensions in parenthesis are for reference only. Controlling dimensions are in inches. Dimensioning and tolerancing per ASME Y14.5M.
- This drawing is subject to change without notice.
- This dimension does not include mold flash, protrusions, or gate burrs. Mold flash, protrusions, or gate burrs shall not exceed $.006$ [0.15] per side.
- This dimension does not include interlead flash.
- Reference JEDEC registration MS-012, variation AA.

EXAMPLE BOARD LAYOUT

D0008A

SOIC - 1.75 mm max height

SMALL OUTLINE INTEGRATED CIRCUIT



LAND PATTERN EXAMPLE
 EXPOSED METAL SHOWN
 SCALE:8X



SOLDER MASK DETAILS

4214825/C 02/2019

NOTES: (continued)

- 6. Publication IPC-7351 may have alternate designs.
- 7. Solder mask tolerances between and around signal pads can vary based on board fabrication site.

EXAMPLE STENCIL DESIGN

D0008A

SOIC - 1.75 mm max height

SMALL OUTLINE INTEGRATED CIRCUIT



SOLDER PASTE EXAMPLE
BASED ON .005 INCH [0.125 MM] THICK STENCIL
SCALE:8X

4214825/C 02/2019

NOTES: (continued)

8. Laser cutting apertures with trapezoidal walls and rounded corners may offer better paste release. IPC-7525 may have alternate design recommendations.
9. Board assembly site may have different recommendations for stencil design.



- NOTES:
- A. All linear dimensions are in millimeters.
 - B. This drawing is subject to change without notice.
 - C. Publication IPC-7351 is recommended for alternate designs.
 - D. Laser cutting apertures with trapezoidal walls and also rounding corners will offer better paste release. Customers should contact their board assembly site for stencil design recommendations. Refer to IPC-7525 for other stencil recommendations.
 - E. Customers should contact their board fabrication site for solder mask tolerances between and around signal pads.

IMPORTANT NOTICE AND DISCLAIMER

TI PROVIDES TECHNICAL AND RELIABILITY DATA (INCLUDING DATASHEETS), DESIGN RESOURCES (INCLUDING REFERENCE DESIGNS), APPLICATION OR OTHER DESIGN ADVICE, WEB TOOLS, SAFETY INFORMATION, AND OTHER RESOURCES "AS IS" AND WITH ALL FAULTS, AND DISCLAIMS ALL WARRANTIES, EXPRESS AND IMPLIED, INCLUDING WITHOUT LIMITATION ANY IMPLIED WARRANTIES OF MERCHANTABILITY, FITNESS FOR A PARTICULAR PURPOSE OR NON-INFRINGEMENT OF THIRD PARTY INTELLECTUAL PROPERTY RIGHTS.

These resources are intended for skilled developers designing with TI products. You are solely responsible for (1) selecting the appropriate TI products for your application, (2) designing, validating and testing your application, and (3) ensuring your application meets applicable standards, and any other safety, security, or other requirements. These resources are subject to change without notice. TI grants you permission to use these resources only for development of an application that uses the TI products described in the resource. Other reproduction and display of these resources is prohibited. No license is granted to any other TI intellectual property right or to any third party intellectual property right. TI disclaims responsibility for, and you will fully indemnify TI and its representatives against, any claims, damages, costs, losses, and liabilities arising out of your use of these resources.

TI's products are provided subject to TI's Terms of Sale (www.ti.com/legal/termsofsale.html) or other applicable terms available either on ti.com or provided in conjunction with such TI products. TI's provision of these resources does not expand or otherwise alter TI's applicable warranties or warranty disclaimers for TI products.

Mailing Address: Texas Instruments, Post Office Box 655303, Dallas, Texas 75265
Copyright © 2019, Texas Instruments Incorporated

Looking for pricing, stock, or lifecycle information?

Click below to explore more details on WIN SOURCE:

 [View SN65LVDS101DGKRG4 on WIN SOURCE](#)

 [Texas Instruments](#) Information

Optimize Your Supply Chain with WIN SOURCE Solutions

-  Global Sourcing Solution
-  Obsolete Management
-  Cost Control Management
-  Shortage Management
-  Alternative Solution
-  Excess Inventory Management