



THE DATASHEET OF AS1973





austriamicrosystems AG

is now

ams AG

The technical content of this austriamicrosystems datasheet is still valid.

Contact information:

Headquarters:

ams AG

Tobelbaderstrasse 30

8141 Unterpremstaetten, Austria

Tel: +43 (0) 3136 500 0

e-Mail: ams_sales@ams.com

Please visit our website at www.ams.com

AS1970 - AS1975

Low-Voltage Single/Dual/Quad Comparators

Data Sheet

1 General Description

The AS1970 - AS1975 are single/dual/quad comparators that operate with supplies from 2.5 to 5.5V making them perfect for all 3- and 5-volt applications. The comparators can also operate with dual supplies (± 1.25 to ± 2.75 V), and require very little supply current (down to $8.5\mu\text{A}$) with minimal propagation delay (300ns).

Low input bias current (1.0pA , typ), low input offset voltage (0.5mV , typ), and internal hysteresis (3mV) make these comparators ideal for low-power single-cell applications including power-management and power-monitoring systems.

The comparators are available as the standard products listed in [Table 1](#).

Table 1. Standard Products

Model	Output Type
AS1970/AS1972/AS1974	Push/Pull
AS1971/AS1973/AS1975	Open-Drain

The AS1970/AS1972/AS1974 push/pull output can sink or source current.

The AS1971/AS1973/AS1975 open-drain output can be pulled beyond V_{CC} to a maximum of $5.5\text{V} > V_{EE}$. These open-drain versions are ideal for logic-level translators or bipolar-to-unipolar converters.

Large internal output drivers allow Rail-to-Rail output swings with loads of up to 8mA .

The AS1970/AS1971 are available in a 5-pin SOT23 package. The AS1972/AS1973 are available in a 8-pin MSOP package. The AS1974/AS1975 are available in a 14-pin TSSOP package.

Figure 1. Block Diagrams

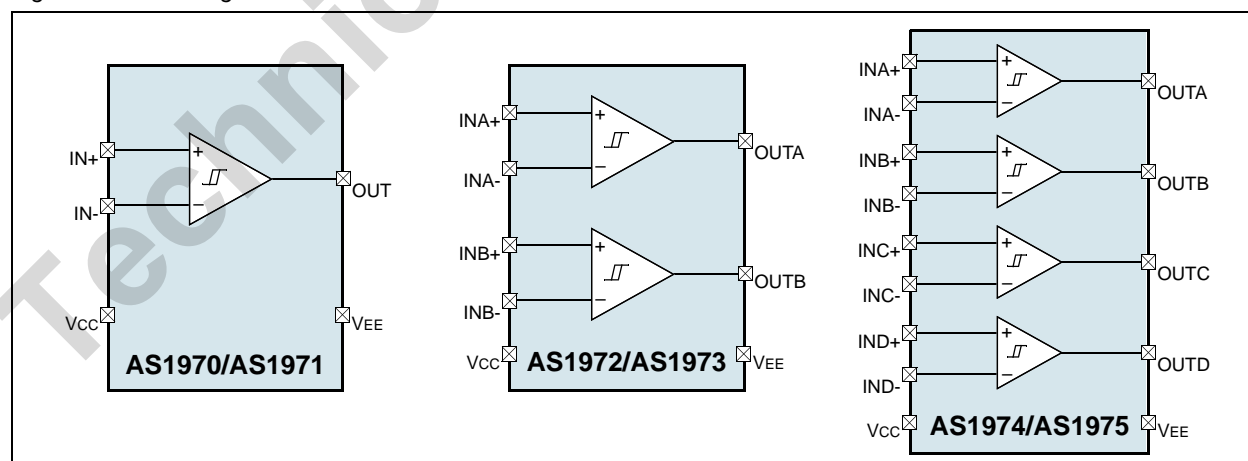

2 Key Features

- CMOS Push/Pull Output Sinks and Sources 8mA (AS1970/AS1972/AS1974)
- CMOS Open-Drain Output Voltage Extends Beyond V_{CC} (AS1971/AS1973/AS1975)
- Quiescent Supply Current: $8.5\mu\text{A}$ per Comparator
- Internal Hysteresis: 3mV
- 3V/5V Logic-Level Translation
- Single-Supply Operation: 2.5 to 5.5V
- Common-Mode Input Voltage Range Extends 250mV Above the Rails
- Low Propagation Delay: 300ns
- Minimized Overall Power Consumption
- Supply Current @ 1MHz Switching Frequency: $80\mu\text{A}$
- No Phase Reversal for Overdriven Inputs
- Package Types:
 - 5-pin SOT23 – AS1970/AS1971
 - 8-pin MSOP – AS1972/AS1973
 - 14-pin TSSOP – AS1974/AS1975

3 Applications

The devices are ideal for battery-powered systems, mobile communication devices, zero-crossing detectors, window comparators, level translators, threshold detectors/discriminators, ground/supply-sensing applications, IR receivers or any other space-limited application with low power-consumption requirements.

4 Pinout and Packaging

Pin Assignments

Figure 2. Pin Assignments (Top View)

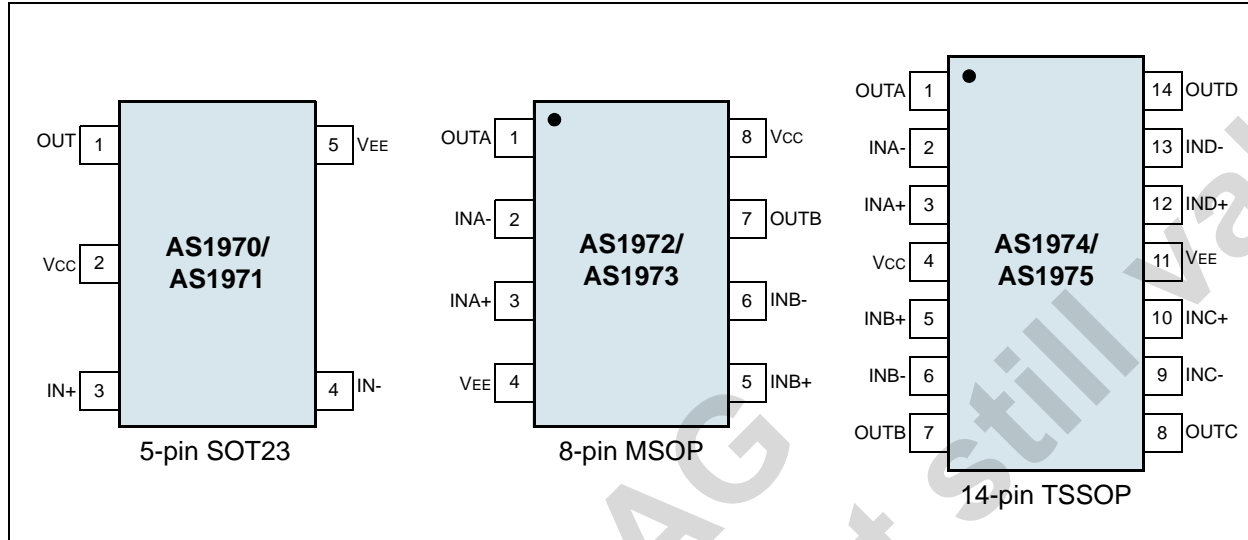

Pin Descriptions

Table 2. Pin Descriptions

Pin Number	Pin Name	Description
See Figure 2	IN-	Comparator Inverting Input
	IN+	Comparator Non-Inverting Input
	INA-	Comparator A Inverting Input
	INA+	Comparator A Non-Inverting Input
	INB-	Comparator B Inverting Input
	INB+	Comparator B Non-Inverting Input
	INC-	Comparator C Inverting Input
	INC+	Comparator C Non-Inverting Input
	IND-	Comparator D Inverting Input
	IND+	Comparator D Non-Inverting Input
	OUT	Comparator Output
	OUTA	Comparator A Output
	OUTB	Comparator B Output
	OUTC	Comparator C Output
	OUTD	Comparator D Output
	VCC	Positive Supply Voltage
VEE	Negative Supply Voltage	

5 Absolute Maximum Ratings

Stresses beyond those listed in [Table 3](#) may cause permanent damage to the device. These are stress ratings only, and functional operation of the device at these or any other conditions beyond those indicated in [Section 6 Electrical Characteristics on page 4](#) is not implied. Exposure to absolute maximum rating conditions for extended periods may affect device reliability.

Table 3. Absolute Maximum Ratings

Parameter		Min	Max	Units	Comments
Supply Voltage VCC to VEE			7	V	
INx+, INx- to VEE		-0.3	VCC + 0.3	V	
OUTx to VEE	AS1970/AS1972/AS1974	-0.3	VCC + 0.3	V	
	AS1971/AS1973/AS1975	-0.3	+7	V	
OUTx Short-Circuit Duration to VEE or VCC			10	s	
Continuous Power Dissipation (TAMB = +70°C)	5-pin SOT23		571	mW	Derate 7.1mW/°C above +70°C
	8-pin MSOP		727	mW	Derate 9.1mW/°C above +70°C
	14-pin TSSOP		727	mW	Derate 9.1mW/°C above +70°C
Operating Temperature Range		-40	+85	°C	
Junction Temperature Range			+150	°C	
Storage Temperature Range		-65	+150	°C	
Package Body Temperature			260	°C	The reflow peak soldering temperature (body temperature) specified is in accordance with IPC/JEDEC J-STD-020C "Moisture/Reflow Sensitivity Classification for Non-Hermetic Solid State Surface Mount Devices". The lead finish for Pb-free leaded packages is matte tin (100% Sn).

6 Electrical Characteristics

$V_{CC} = 2.7$ to $5.5V$, $V_{EE} = 0V$, $V_{CM} = 0V$, $T_{AMB} = -40$ to $+85^{\circ}C$ (unless otherwise specified). Typ values are at $T_{AMB} = +25^{\circ}C$.

Table 4. Electrical Characteristics

Symbol	Parameter	Conditions	Min	Typ	Max	Units
V _{CC}	Supply Voltage	Inferred from PSRR test	2.5		5.5	V
I _{DD}	Supply Current	V _{CC} = 5V, No Load, AS1974/AS1975		36	64	μA
		V _{CC} = 5V, No Load, AS1972/AS1973		18	32	
		V _{CC} = 5V, No Load, AS1970, AS1971		11	19	
		V _{CC} = 2.7V, No Load, AS1974/AS1975		34	60	
		V _{CC} = 2.7V, No Load, AS1972/AS1973		17	30	
		V _{CC} = 2.7V, No Load, AS1970, AS1971		10	18	
PSRR	Power-Supply Rejection Ratio	$2.5V \leq V_{CC} \leq 5.5V$, $T_{AMB} = +25^{\circ}C$	55	80		dB
V _{CMR}	Common-Mode Voltage Range ¹	$T_{AMB} = +25^{\circ}C$	V _{EE} - 0.25		V _{CC} + 0.25	V
		$T_{AMB} = -40$ to $+85^{\circ}C$	V _{EE}		V _{CC}	
V _{OS}	Input Offset Voltage ²	Full Common-Mode Range, $T_{AMB} = +25^{\circ}C$		±0.5	±6	mV
		Full Common-Mode Range, $T_{AMB} = -40$ to $+85^{\circ}C$			±8	
V _{HYS}	Input Hysteresis			±3		mV
I _B	Input Bias Current ^{3, 4}			0.001	10	nA
I _{OS}	Input Offset Current			0.5		pA
C _{IN}	Input Capacitance			3.5		pF
CMRR	Common-Mode Rejection Ratio	$T_{AMB} = +25^{\circ}C$	52	80		dB
I _{LEAK}	Output Leakage Current	AS1971/AS1973/AS1975 only			1.0	μA
I _{SC}	Output Short-Circuit Current	Sourcing or Sinking, V _{OUT} = V _{EE} or V _{CC} , V _{CC} = 5V		60		mA
		Sourcing or Sinking, V _{OUT} = V _{EE} or V _{CC} , V _{CC} = 2.7V		18		
V _{OL}	OUT _x Output Voltage Low	V _{CC} = 5V, I _{SINK} = 8mA, $T_{AMB} = +25^{\circ}C$		0.2	0.4	V
		V _{CC} = 5V, I _{SINK} = 8mA, $T_{AMB} = -40$ to $+85^{\circ}C$			0.55	
		V _{CC} = 2.7V, I _{SINK} = 3.5mA, $T_{AMB} = +25^{\circ}C$		0.15	0.3	
		V _{CC} = 2.7V, I _{SINK} = 3.5mA, $T_{AMB} = -40$ to $+85^{\circ}C$			0.4	
V _{OH}	OUT _x Output Voltage High (AS1970/AS1972/AS1974 only)	V _{CC} = 5V, I _{SINK} = 8mA, $T_{AMB} = +25^{\circ}C$	4.6	4.85		V
		V _{CC} = 5V, I _{SINK} = 8mA, $T_{AMB} = -40$ to $+85^{\circ}C$	4.45			
		V _{CC} = 2.7V, I _{SINK} = 3.5mA, $T_{AMB} = +25^{\circ}C$	2.4	2.55		
		V _{CC} = 2.7V, I _{SINK} = 3.5mA, $T_{AMB} = -40$ to $+85^{\circ}C$	2.3			

Table 4. Electrical Characteristics (Continued)

Symbol	Parameter	Conditions	Min	Typ	Max	Units
t _{RISE}	OUTx Rise Time (AS1970/AS1972/AS1974 only)	V _{CC} = 5V, C _{LOAD} = 15pF		32		ns
		V _{CC} = 5V, C _{LOAD} = 50pF		50		
		V _{CC} = 5V, C _{LOAD} = 200pF		80		
t _{FALL}	OUTx Fall Time	V _{CC} = 5V, C _{LOAD} = 15pF		22		ns
		V _{CC} = 5V, C _{LOAD} = 50pF		32		
		V _{CC} = 5V, C _{LOAD} = 200pF		60		
t _{PD-}	Propagation Delay	AS1970/AS1972/AS1974 only, C _{LOAD} = 15pF, 10mV Overdrive		400		ns
		AS1970/AS1972/AS1974 only, C _{LOAD} = 15pF, 100mV Overdrive		300		
		AS1971/AS1973/AS1975 only, C _{LOAD} = 15pF, R _{PULLUP} = 5.1kΩ, 10mV Overdrive		400		
		AS1971/AS1973/AS1975 only, C _{LOAD} = 15pF, R _{PULLUP} = 5.1kΩ, 100mV Overdrive		300		
t _{PD+}	Propagation Delay	AS1970/AS1972/AS1974 only, C _{LOAD} = 15pF, 10mV Overdrive		420		ns
		AS1970/AS1972/AS1974 only, C _{LOAD} = 15pF, 100mV Overdrive		270		
t _{PU}	Power-Up Time			20		μs

1. Inferred from the V_{OS} test. Both or either inputs can be driven 0.3V beyond either supply rail without output phase reversal.
2. V_{OS} is defined as the center of the hysteresis band at the input.
3. I_B is defined as the average of the two input bias currents (I_{B-}, I_{B+}).
4. Guaranteed by design.

7 Typical Operating Characteristics

Figure 3. Supply Current vs. Temperature (per comparator)

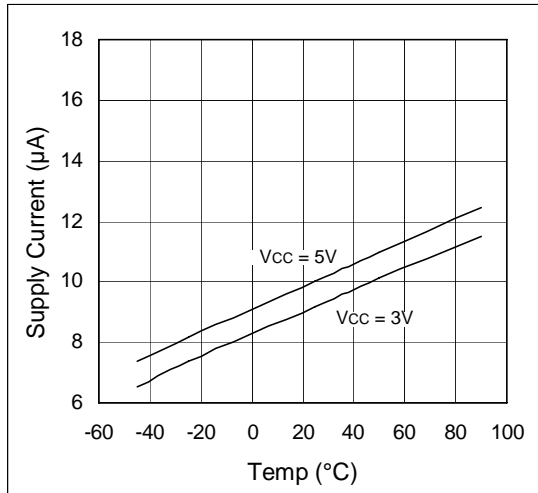

Figure 4. Supply Current vs. Output Transition Frequency (per comparator)

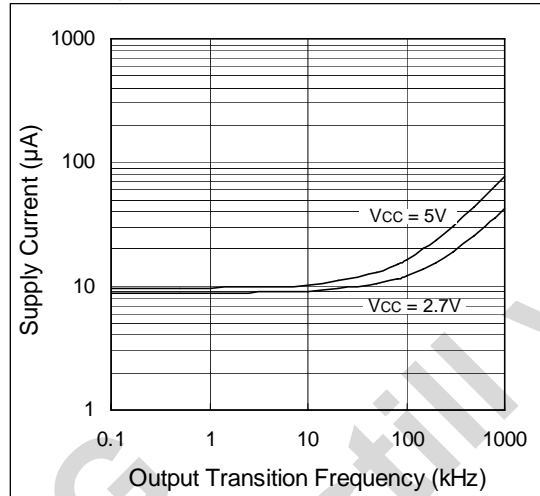

Figure 5. V_{OL} vs. I_{SINK} ; $V_{IN+} < V_{IN-}$

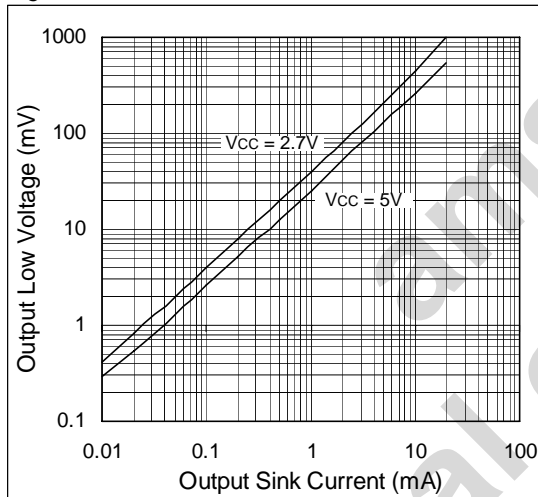

Figure 6. V_{OH} vs. I_{SOURCE} ; $V_{IN+} > V_{IN-}$

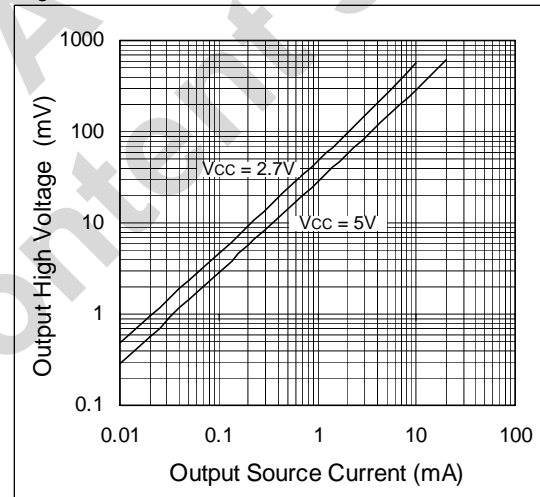

Figure 7. I_{SINK} vs. Temperature

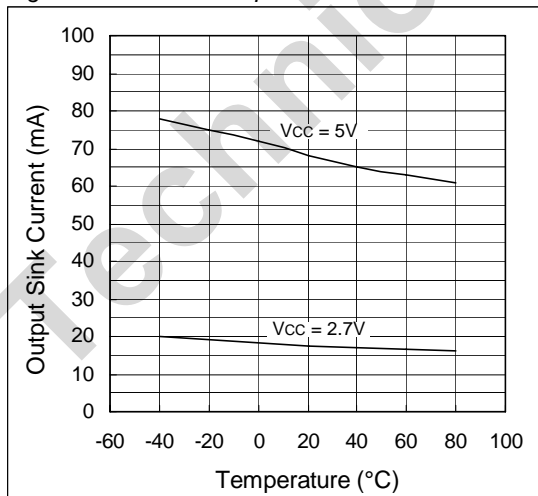

Figure 8. V_{OS} vs. Temperature

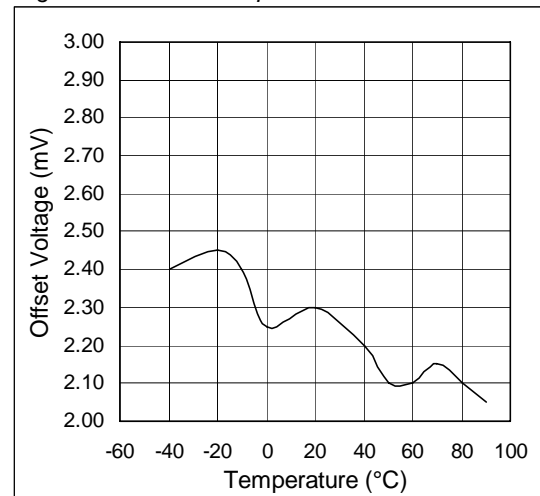

Figure 9. t_{PD+} vs. C_{LOAD} ; $V_{CC} = 3V$, $V_{OD} = 50mV$

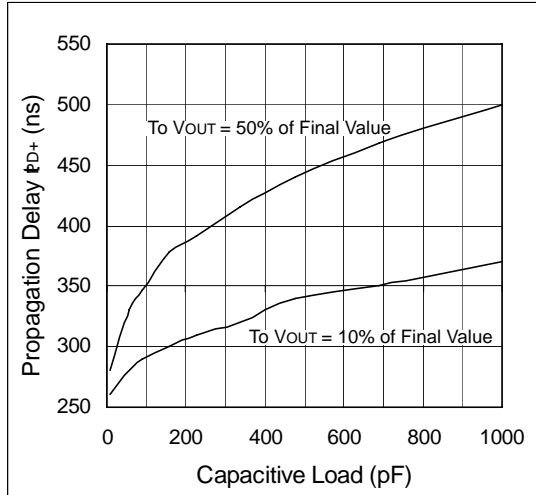

Figure 10. t_{PD+} vs. C_{LOAD} ; $V_{CC} = 5V$, $V_{OD} = 50mV$

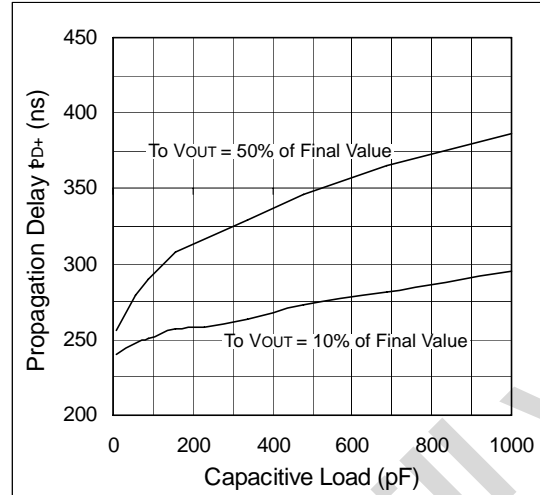

Figure 11. t_{PD+} vs. Temperature; $V_{OD} = 50mV$

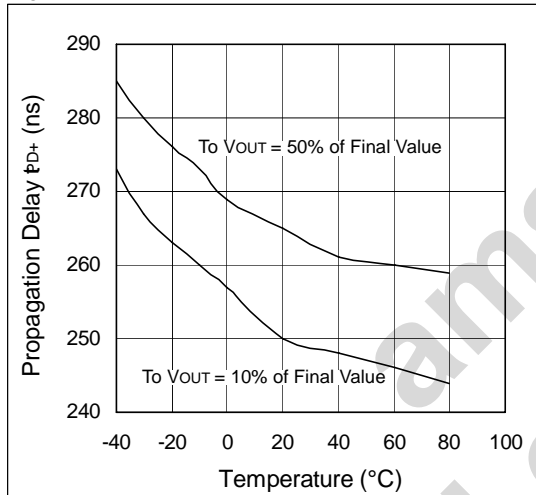

Figure 12. t_{PD+} vs. V_{OD}

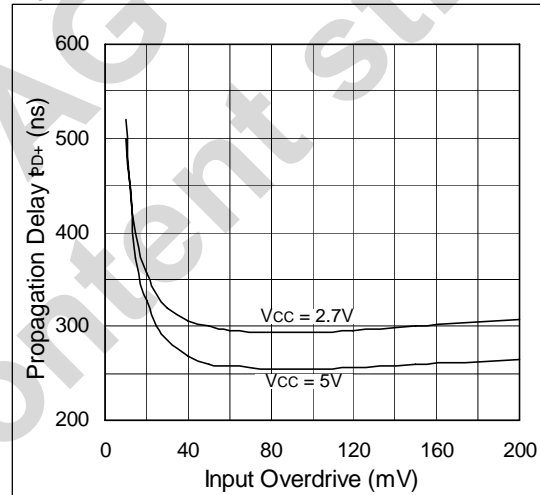

Figure 13. 1MHz Response; $V_{OD} = 50mV$

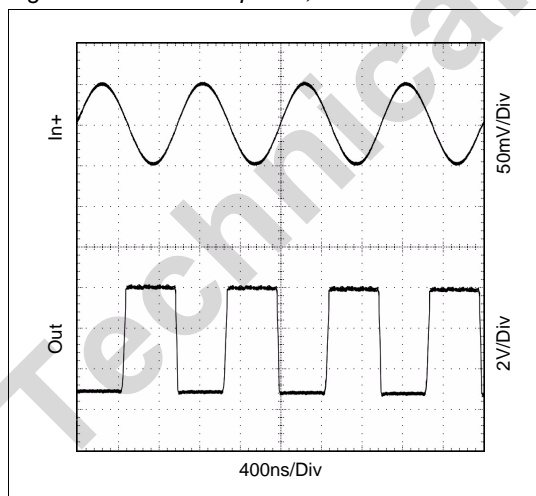

Figure 14. Power-Up Delay; $V_{OD} = 50mV$

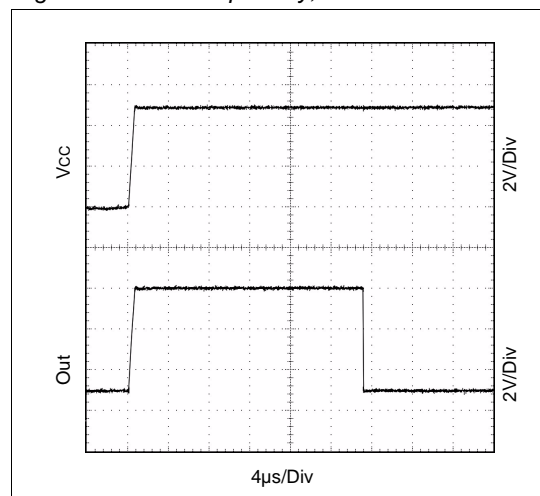

Figure 15. t_{PD+} ; $V_{OD} = 50mV$

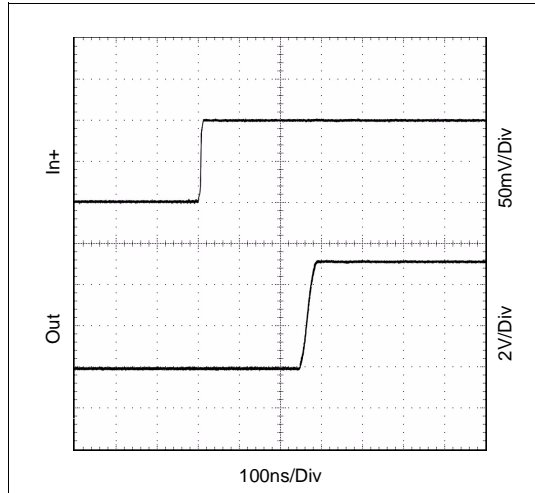
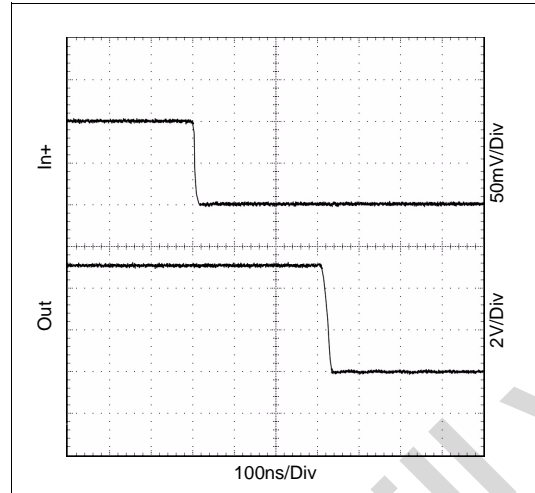

Figure 16. t_{PD-} ; $V_{OD} = 50mV$



ams AG
Technical content still valid

8 Detailed Description

The AS1970 - AS1975 are single/dual/quad low-power, comparators. The devices operate with a supply voltage range between 2.5 and 5.5V while consuming down to 8.5 μ A per comparator. Their common-mode input voltage range extends 0.25V beyond each rail.

Internal hysteresis ensures clean output switching, even with slow input signals. Large internal output drivers allow rail-to-rail output swing with up to 8mA loads.

The output stage design minimizes supply-current surges while switching, virtually eliminating the power supply transients typical. The AS1970/AS1972/AS1974 push/pull output stage sinks and sources current, whereas the AS1971/AS1973/AS1975 open-drain output stage can be pulled beyond V_{CC} to an absolute maximum of $5.5V > V_{EE}$.

Input Stage

The input common-mode voltage range extends from -0.25V to ($V_{CC} + 0.25V$), and the comparators can operate at any differential input voltage within this voltage range. Input bias (I_B) current is 1.0pA (typ) if the input voltage is within the common-mode voltage range.

Inputs are protected from over-voltage by internal ESD protection diodes connected to the supply rails. As the input voltage exceeds the supply rails, these diodes become forward biased and begin to conduct and the bias currents increase exponentially as the input voltage exceeds the supply rails.

Output Stage

The push/pull and open-drain output stages were designed to provide rail-to-rail operation with up to 8mA loads. Even at loads of up to 8mA, the supply-current change during an output transition is extremely small (see [Figure 4 on page 6](#)). [Figure 4](#) shows the minimal supply-current increase as the output switching frequency approaches 1MHz. This characteristic eliminates the need for power-supply filter capacitors to reduce glitches created by comparator switching currents.

Because of the unique design of its output stage, the AS1970 - AS1975 can dramatically increase battery life, even in high-speed applications.

9 Application Information

Figure 17 shows a typical application circuit for the AS1970 - AS1975 comparators.

Figure 17. Typical Application Diagram – Threshold Detector

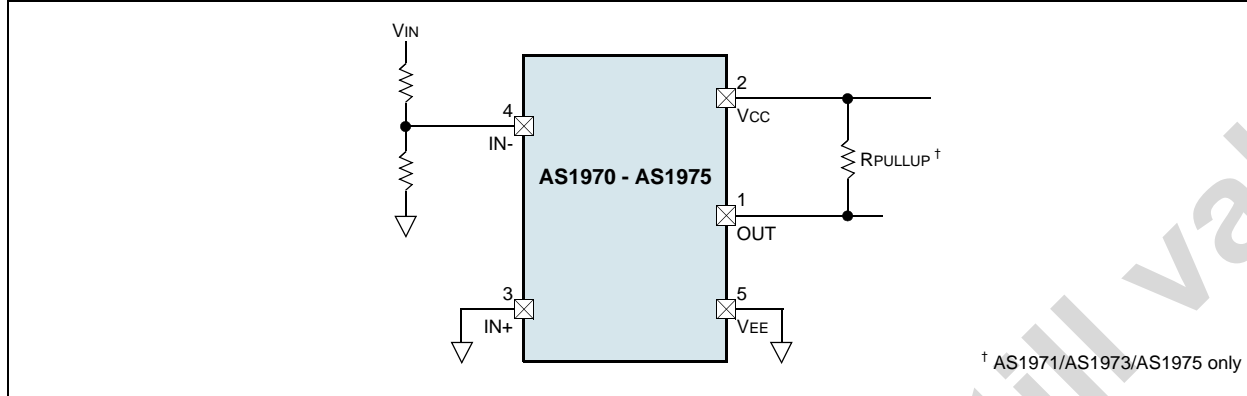

Hysteresis (AS1970/AS1972/AS1974)

The AS1970/AS1972/AS1974 have 3mV internal hysteresis. Additional hysteresis can be generated with three resistors using positive feedback (Figure 18), however this method also slows hysteresis response time.

Figure 18. Additional Hysteresis AS1970/AS1972/AS1974

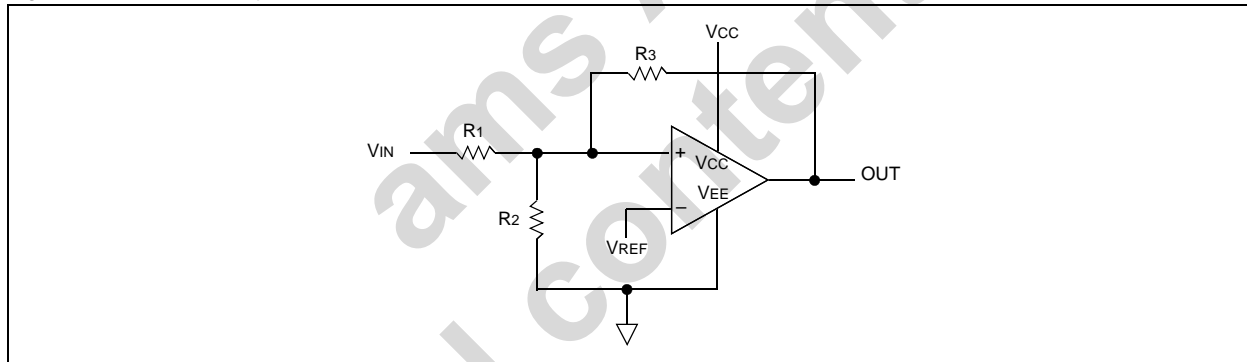

Resistor Selection Example

For the circuit shown in Figure 18, the following steps can be used to calculate values for R1, R2, and R3.

1. Select R3 first. The current through R3 should be at least 1µA to minimize errors caused by leakage current. The current through R3 at the trip point is:

$$(V_{REF} - V_{OUT})/R_3 \quad (EQ 1)$$

The two possible output states in solving for R3 yields these two formulas:

$$R_3 = V_{REF}/1\mu A \quad (EQ 2)$$

$$R_3 = (V_{REF} - V_{CC})/1\mu A \quad (EQ 3)$$

For example, for $V_{REF} = 1.2V$ and $V_{CC} = 5V$, the two R3 resistor values are 1.2MΩ and 3.8MΩ. Use the smaller of the two resulting resistor values; in this case a standard 1.2MΩ resistor should be used for R3.

2. Choose the hysteresis band (V_{HB}). For this example, use $V_{HB} = 50mV$.
3. Calculate R1 according to the following equation:

$$R_1 = R_3(V_{HB}/V_{CC}) \quad (EQ 4)$$

Substituting the example values for R3 and V_{HB} gives:

$$R_1 = 1.2M\Omega(50mV/5V) = 12k\Omega$$

- Choose the trip point for V_{IN} rising (V_{THR}) (see page 12). This is the threshold voltage at which the AS1970 - AS1975 switches its output from low to high as V_{IN} rises above the trip point. For this example, choose $V_{THR} = 3V$.
- Calculate R_2 as:

$$R_2 = 1/[V_{THR}/(V_{REF} \times R_1) - (1/R_1) - (1/R_3)] \quad (EQ 5)$$

Substituting the example values gives:

$$R_2 = 1/[3.0V/(1.2V \times 12k\Omega) - (1/12k\Omega) - (1/1.2M\Omega)] = 8.05k\Omega$$

In this example, a standard $8.2k\Omega$ resistor should be used for R_2 .

- Verify the trip voltages and hysteresis as:

$$V_{THR} = V_{REF} \times R_1 [(1/R_1) + (1/R_2) + (1/R_3)] \quad (EQ 6)$$

$$V_{THF} = V_{THR} - (R_1 \times V_{CC}/R_3) \quad (EQ 7)$$

$$\text{Hysteresis} = V_{THR} - V_{THF} \quad (EQ 8)$$

Hysteresis (AS1971/AS1973/AS1975)

The AS1971/AS1973/AS1975 have 3mV internal hysteresis. Their open-drain outputs require an external pullup resistor (Figure 19), and additional hysteresis can be generated using positive feedback.

Figure 19. Additional Hysteresis AS1971/AS1973/AS1975

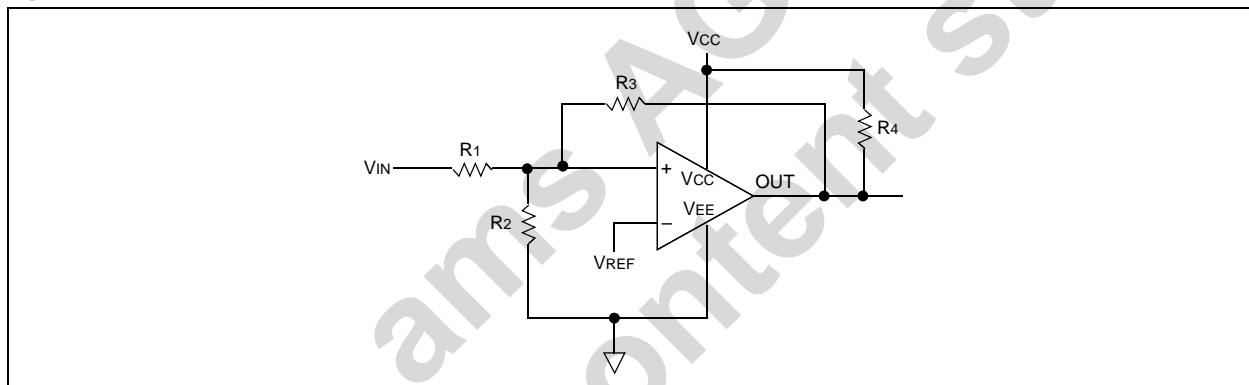

Resistor Selection Example

For the circuit shown in Figure 19, the following steps can be used to calculate values for R_1 , R_2 , R_3 , and R_4 :

- Select R_3 according to one of:

$$R_3 = V_{REF}/500\mu A \quad (EQ 9)$$

$$R_3 = (V_{REF} - V_{CC})/500\mu A - R_4 \quad (EQ 10)$$

Use the smaller of the two resulting resistor values.

- Choose the hysteresis band required (V_{HB}). For this example, use 50mV.
- Calculate R_1 as:

$$R_1 = (R_3 + R_4)(V_{HB}/V_{CC}) \quad (EQ 11)$$

- Choose the trip point for V_{IN} rising (V_{THR}) (see page 12). This is the threshold voltage at which the comparator switches its output from low to high as V_{IN} rises above the trip point.
- Calculate R_2 as:

$$R_2 = 1/[V_{THR}/(V_{REF} \times R_1) - (1/R_1) - 1/(R_3 + R_4)] \quad (EQ 12)$$

- Verify the trip voltages and hysteresis as follows:

$$V_{IN \text{ rising:}} V_{THR} = V_{REF} \times R_1 \times [1/R_1 + 1/R_2 + 1/(R_3 + R_4)] \quad (EQ 13)$$

$$V_{IN \text{ falling:}} V_{THF} = V_{REF} \times R_1 \times [1/R_1 + 1/R_2 + 1/(R_3 + R_4)] - 1/(R_3 + R_4) \times V_{CC} \quad (EQ 14)$$

$$\text{Hysteresis} = V_{THR} - V_{THF} \quad (EQ 15)$$

Hysteresis Band

Internal hysteresis creates two trip points (shown in Figure 20): rising input voltage (V_{THR}) and falling input voltage (V_{THF}). The area between the trip points is the hysteresis band (V_{HB}). When the comparator input voltages are equivalent, the hysteresis effectively causes one comparator input to move quickly past the other, thus taking the input out of the region where oscillation occurs.

In Figure 20 REF has a fixed voltage applied and IN+ is varied. If the inputs are reversed the output will be inverted.

Figure 20. Threshold Hysteresis Band

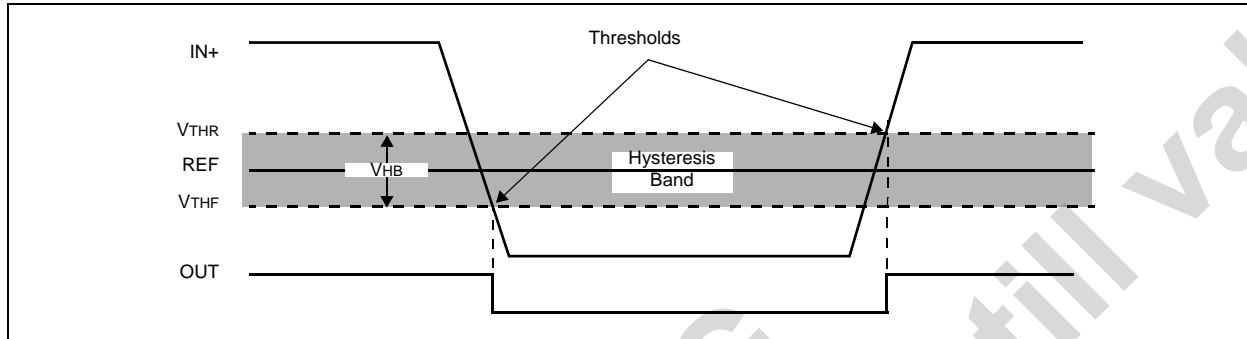

Zero-Crossing Detector

Figure 21 shows the AS1970 in a zero-crossing detector circuit. The inverting input is connected to ground, and the non-inverting input is connected to a 100mVp-p signal source. As the signal at the non-inverting input crosses 0V, the signal at OUT changes states.

Figure 21. Zero-Crossing Detector

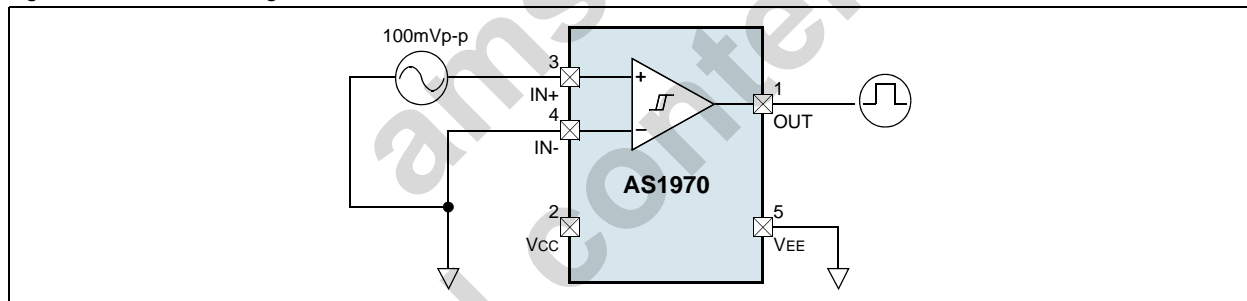

Logic Level Translator

The comparators can be used as a 5V/3V logic translator as shown in Figure 22. The circuit in Figure 22 converts 5V-to-3V-logic levels, and provides the full 5V logic-swing without creating overvoltage on the 3V logic inputs. When the comparator is powered by a 5V supply, R_{PULLUP} for the open-drain output should be connected to the +3V supply voltage.

For 3V-to-5V logic-level translations, connect the +3V supply voltage to VCC and the +5V supply voltage to R_{PULLUP} .

Figure 22. Logic Level Translator

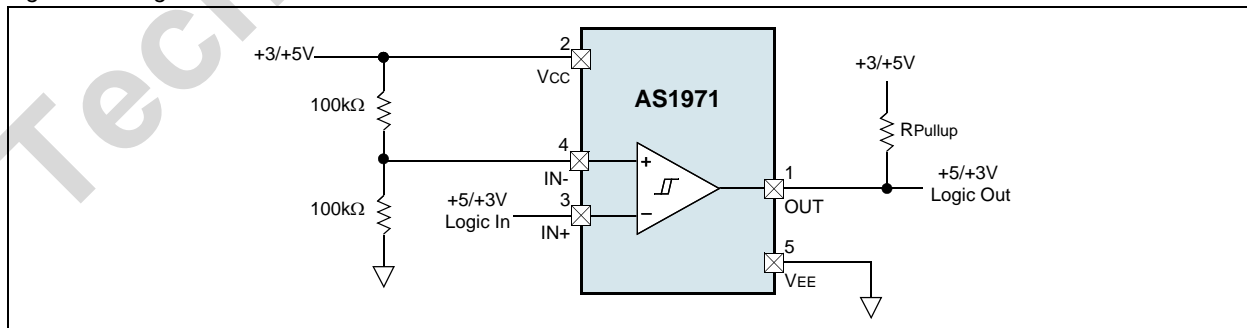

Layout Considerations

The AS1970 - AS1975 requires proper layout and design techniques for optimum performance.

- Power-supply bypass capacitors are not typically needed, although 100nF bypass capacitors should be used when supply impedance is high, when supply leads are long, or when excessive noise is expected on the supply lines.
- Minimize signal trace lengths to reduce stray capacitance.
- A ground plane and surface-mount components are recommended.

ams AG
Technical content still valid

10 Package Drawings and Markings

The AS1970 - AS1975 are available in a 5-pin SOT23 package and an 8-pin MSOP package.

Figure 23. 5-pin SOT23 Package

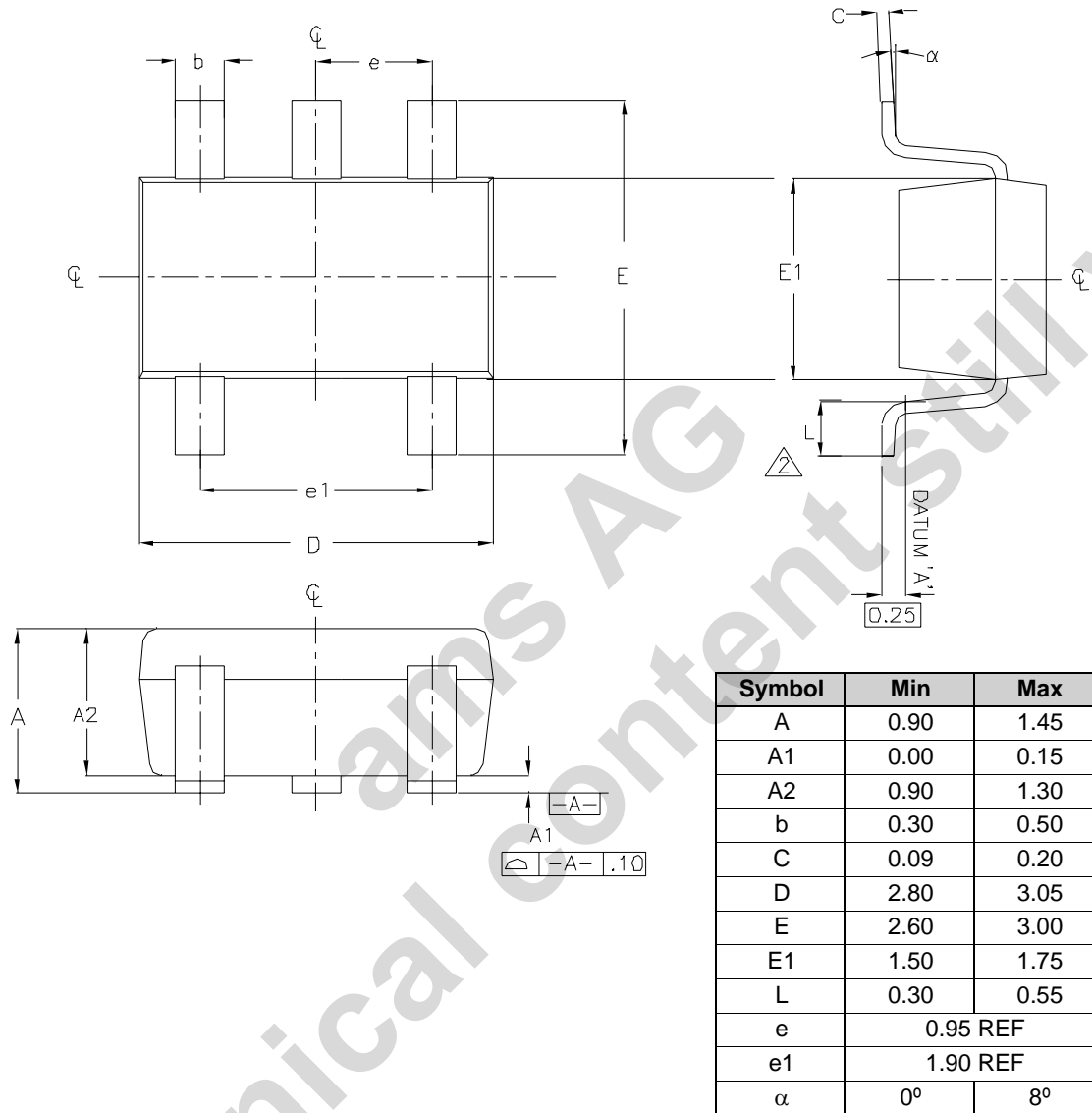

Notes:

1. Controlling dimension is millimeters.
2. Foot length measured at intercept point between datum A and lead surface.
3. Package outline exclusive of mold flash and metal burr.
4. Package outline inclusive of solder plating.
5. Meets JEDEC MO178.

Figure 25. 14-pin TSSOP Package

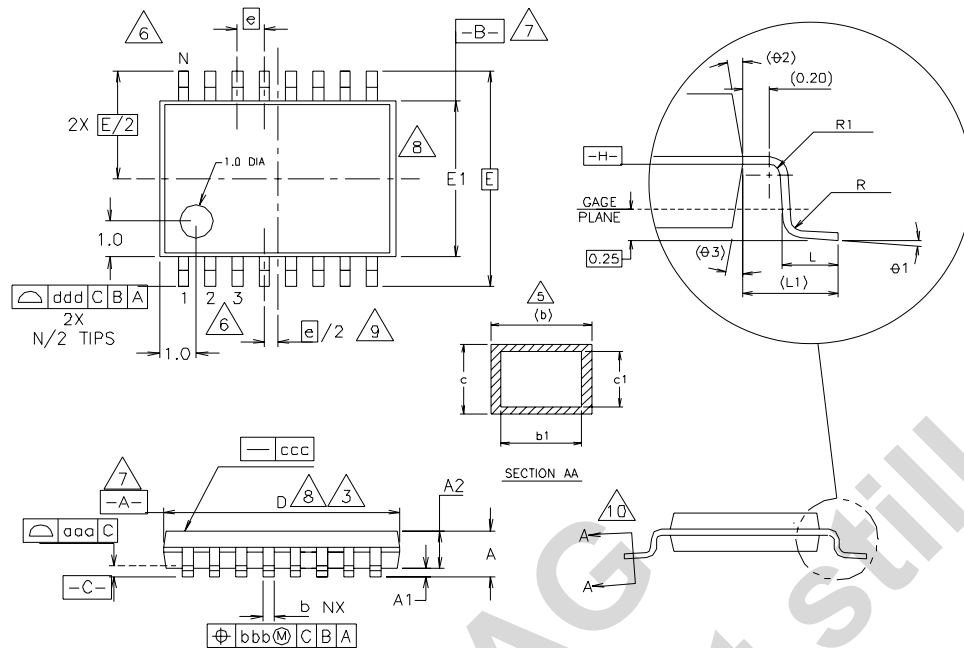

Symbol	0.65mm Lead Pitch ^{1,2}			Note	Symbol	0.65mm Lead Pitch ^{1,2}			Note
	Min	Nom	Max			Min	Nom	Max	
A	-	-	1.10		θ1	0°	-	8°	
A1	0.05	-	0.15		L1	1.0 Ref			
A2	0.85	0.90	0.95		aaa	0.10			
L	0.50	0.60	0.75		bbb	0.10			
R	0.09	-	-		ccc	0.05			
R1	0.09	-	-		ddd	0.20			
b	0.19	-	0.30	5	e	0.65 BSC			
b1	0.19	0.22	0.25		θ2	12° Ref			
c	0.09	-	0.20		θ3	12° Ref			
c1	0.09	-	0.16						
Variations									
D	4.90	5.00	5.10	3, 8	e	0.65 BSC			
E1	4.30	1.40	4.50	4, 8	N	14			6
E	6.4 BSC								

Notes:

- All dimensions are in millimeters; angles in degrees.
- Dimensions and tolerancing per ASME Y14.5M-1994.
- Dimension D does not include mold flash, protrusions, or gate burrs. Mold flash, protrusions, or gate burrs shall not exceed 0.15mm per side.
- Dimension E1 does not include interlead flash or protrusion. Interlead flash or protrusion shall not exceed 0.25mm per side.
- Dimension b does not include dambar protrusion. Allowable dambar protrusion shall be 0.08mm total in excess of dimension b at maximum material condition. Dambar cannot be located on the lower radius of the foot. Minimum space between protrusion and adjacent lead is 0.07mm for 0.5mm pitch packages.
- Terminal numbers shown are for reference only.
- Datums A and B to be determined at datum plane H.
- Dimensions D and E1 to be determined at datum plane H.
- This dimension applies only to variations with an even number of leads per side. For variations with an odd number of leads per package, the center lead must be coincident with the package centerline, datum A.
- Cross section A-A to be determined at 0.10 to 0.25mm from the leadtip.

11 Ordering Information

The comparators are available as the standard products shown in [Table 5](#).

Table 5. Ordering Information

Model	Marking	Description	Delivery Form	Package
AS1970-T	ASI6	Low-Voltage Single Comparator, Push/Pull	Tape and Reel	5-pin SOT23
AS1971-T	ASI7	Low-Voltage Single Comparator, Open-Drain	Tape and Reel	5-pin SOT23
AS1972	989	Low-Voltage Dual Comparator, Push/Pull	Tubes	8-pin MSOP
AS1972-T	989	Low-Voltage Dual Comparator Push/Pull	Tape and Reel	8-pin MSOP
AS1973	990	Low-Voltage Dual Comparator, Open-Drain	Tubes	8-pin MSOP
AS1973-T	990	Low-Voltage Dual Comparator, Open-Drain	Tape and Reel	8-pin MSOP
AS1974	AS1974	Low-Voltage Quad Comparator, Push/Pull	Tubes	14-pin TSSOP
AS1974-T	AS1974	Low-Voltage Quad Comparator, Push/Pull	Tape and Reel	14-pin TSSOP
AS1975	AS1975	Low-Voltage Quad Comparator, Open-Drain	Tubes	14-pin TSSOP
AS1975-T	AS1975	Low-Voltage Quad Comparator, Open-Drain	Tape and Reel	14-pin TSSOP

Copyrights

Copyright © 1997-2007, austriamicrosystems AG, Schloss Premstaetten, 8141 Unterpremstaetten, Austria-Europe. Trademarks Registered ®. All rights reserved. The material herein may not be reproduced, adapted, merged, translated, stored, or used without the prior written consent of the copyright owner.

All products and companies mentioned are trademarks or registered trademarks of their respective companies.

Disclaimer

Devices sold by austriamicrosystems AG are covered by the warranty and patent indemnification provisions appearing in its Term of Sale. austriamicrosystems AG makes no warranty, express, statutory, implied, or by description regarding the information set forth herein or regarding the freedom of the described devices from patent infringement. austriamicrosystems AG reserves the right to change specifications and prices at any time and without notice. Therefore, prior to designing this product into a system, it is necessary to check with austriamicrosystems AG for current information. This product is intended for use in normal commercial applications. Applications requiring extended temperature range, unusual environmental requirements, or high reliability applications, such as military, medical life-support or life-sustaining equipment are specifically not recommended without additional processing by austriamicrosystems AG for each application. For shipments of less than 100 parts the manufacturing flow might show deviations from the standard production flow, such as test flow or test location.

The information furnished here by austriamicrosystems AG is believed to be correct and accurate. However, austriamicrosystems AG shall not be liable to recipient or any third party for any damages, including but not limited to personal injury, property damage, loss of profits, loss of use, interruption of business or indirect, special, incidental or consequential damages, of any kind, in connection with or arising out of the furnishing, performance or use of the technical data herein. No obligation or liability to recipient or any third party shall arise or flow out of austriamicrosystems AG rendering of technical or other services.



Contact Information

Headquarters

austriamicrosystems AG
A-8141 Schloss Premstaetten, Austria

Tel: +43 (0) 3136 500 0
Fax: +43 (0) 3136 525 01

For Sales Offices, Distributors and Representatives, please visit:

<http://www.austriamicrosystems.com/contact>

Looking for pricing, stock, or lifecycle information?

Click below to explore more details on WIN SOURCE:

- ⊖ [View AS1973 on WIN SOURCE](#)
- ⊖ [OSRAM Opto Semiconductors Inc. Information](#)

Optimize Your Supply Chain with WIN SOURCE Solutions

- ✓ Global Sourcing Solution
- ✓ Obsolete Management
- ✓ Cost Control Management
- ✓ Shortage Management
- ✓ Alternative Solution
- ✓ Excess Inventory Management