



# THE DATASHEET OF AD5323ARU



### FEATURES

- AD5303: 2 buffered 8-bit DACs in 1 package**  
A version:  $\pm 1$  LSB INL, B version:  $\pm 0.5$  LSB INL
- AD5313: 2 buffered 10-bit DACs in 1 package**  
A version:  $\pm 4$  LSB INL, B version:  $\pm 2$  LSB INL
- AD5323: 2 buffered 12-bit DACs in 1 package**  
A version:  $\pm 16$  LSB INL, B version:  $\pm 8$  LSB INL
- 16-lead TSSOP package**
- Micropower operation: 300  $\mu$ A @ 5 V (including reference current)**
- Power-down to 200 nA @ 5 V, 50 nA @ 3 V**
- 2.5 V to 5.5 V power supply**
- Double-buffered input logic**
- Guaranteed monotonic by design over all codes**
- Buffered/unbuffered reference input options**
- Output range: 0 V to  $V_{REF}$  or 0 V to  $2 V_{REF}$**
- Power-on-reset to 0 V**
- SDO daisy-chaining option**
- Simultaneous update of DAC outputs via  $\overline{LDAC}$  pin**
- Asynchronous CLR facility**
- Low power serial interface with Schmitt-triggered inputs**
- On-chip rail-to-rail output buffer amplifiers**

### APPLICATIONS

- Portable battery-powered instruments
- Digital gain and offset adjustment
- Programmable voltage and current sources
- Programmable attenuators

### GENERAL DESCRIPTION

The AD5303/AD5313/AD5323 are dual 8-/10-/12-bit buffered voltage output DACs in a 16-lead TSSOP package that operate from a single 2.5 V to 5.5 V supply, consuming 230  $\mu$ A at 3 V. Their on-chip output amplifiers allow the outputs to swing rail-to-rail with a slew rate of 0.7 V/ $\mu$ s. The AD5303/AD5313/AD5323 utilize a versatile 3-wire serial interface that operates at clock rates up to 30 MHz and is compatible with standard SPI, QSPI<sup>™</sup>, MICROWIRE<sup>™</sup>, and DSP interface standards.

The references for the two DACs are derived from two reference pins (one per DAC). These reference inputs may be configured as buffered or unbuffered inputs. The parts incorporate a power-on reset circuit, which ensures that the DAC outputs power up to 0 V and remain there until a valid write to the device takes place. There is also an asynchronous active low  $\overline{CLR}$  pin that clears both DACs to 0 V. The outputs of both DACs may be updated simultaneously using the asynchronous  $\overline{LDAC}$  input. The parts contain a power-down feature that reduces the current consumption of the devices to 200 nA at 5 V (50 nA at 3 V) and provides software-selectable output loads while in power-down mode. The parts may also be used in daisy-chaining applications using the SDO pin.

The low power consumption of these parts in normal operation makes them ideally suited to portable battery-operated equipment. The power consumption is 1.5 mW at 5 V and 0.7 mW at 3 V, reducing to 1  $\mu$ W in power-down mode.

### FUNCTIONAL BLOCK DIAGRAM

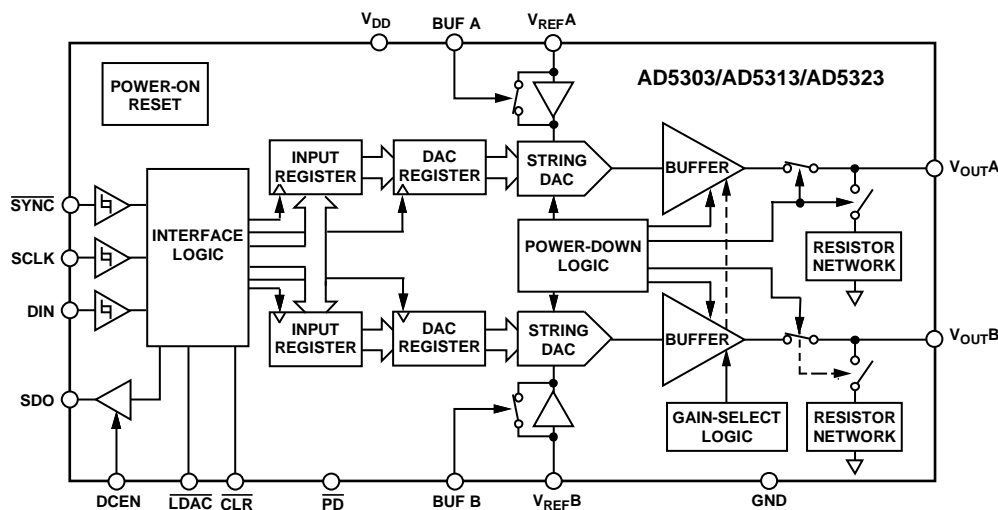

Figure 1.

### Rev. B

Information furnished by Analog Devices is believed to be accurate and reliable. However, no responsibility is assumed by Analog Devices for its use, nor for any infringements of patents or other rights of third parties that may result from its use. Specifications subject to change without notice. No license is granted by implication or otherwise under any patent or patent rights of Analog Devices. Trademarks and registered trademarks are the property of their respective owners.

## TABLE OF CONTENTS

Features .....	1	Input Shift Register .....	17
Applications.....	1	Low Power Serial Interface .....	17
General Description .....	1	Double-Buffered Interface .....	17
Functional Block Diagram .....	1	Power-Down Modes .....	19
Revision History .....	2	Microprocessor Interfacing .....	20
Specifications.....	3	AD5303/AD5313/AD5323 to ADSP-2101 Interface.....	20
AC Characteristics.....	6	AD5303/AD5313/AD5323 to 68HC11/68L11 Interface .....	20
Timing Characteristics .....	6	AD5303/AD5313/AD5323 to 80C51/80L51 Interface.....	20
Absolute Maximum Ratings.....	8	AD5303/AD5313/AD5323 to MICROWIRE Interface .....	20
ESD Caution.....	8	Applications Information .....	21
Pin Configuration and Function Descriptions.....	9	Typical Application Circuit.....	21
Terminology .....	10	Bipolar Operation Using the AD5303/AD5313/AD5323.....	21
Typical Performance Characteristics .....	11	Opto-Isolated Interface for Process Control Applications ...	22
Functional Description .....	15	Decoding Multiple AD5303/AD5313/AD5323s.....	22
Digital-to-Analog .....	15	AD5303/AD5313/AD5323 as a Digitally Programmable	
Resistor String.....	15	Window Detector .....	22
DAC Reference Inputs .....	15	Coarse and Fine Adjustment Using the	
Output Amplifier.....	15	AD5303/AD5313/AD5323 .....	23
Power-On Reset .....	16	Daisy-Chain Mode .....	23
Clear Function ( $\overline{\text{CLR}}$ ) .....	16	Power Supply Bypassing and Grounding.....	24
Serial Interface .....	17	Outline Dimensions .....	25
		Ordering Guide .....	25

## REVISION HISTORY

### 6/07—Rev. A to Rev. B

Updated Format.....	Universal
Changes to Table 4.....	8
Changes to the Ordering Guide.....	25

### 8/03—Rev. 0 to Rev. A

Added A Version.....	Universal
Changes to Features.....	1
Changes to Specifications .....	2
Changes to Absolute Maximum Ratings .....	5
Changes to Ordering Guide .....	5
Updated Outline Dimensions .....	18

### 4/99—Revision 0: Initial Version

## SPECIFICATIONS

$V_{DD} = 2.5\text{ V to }5.5\text{ V}$ ;  $V_{REF} = 2\text{ V}$ ;  $R_L = 2\text{ k}\Omega$  to GND;  $C_L = 200\text{ pF}$  to GND; all specifications  $T_{MIN}$  to  $T_{MAX}$ , unless otherwise noted.

Table 1.

Parameter <sup>2</sup>	A Version <sup>1</sup>			B Version <sup>1</sup>			Unit	Conditions/Comments	
	Min	Typ	Max	Min	Typ	Max			
DC PERFORMANCE <sup>3, 4</sup>									
AD5303									
Resolution		8		8			Bits	Guaranteed monotonic by design over all codes	
Relative Accuracy		$\pm 0.15$	$\pm 1$	$\pm 0.15$	$\pm 0.5$		LSB		
Differential Nonlinearity		$\pm 0.02$	$\pm 0.25$	$\pm 0.02$	$\pm 0.25$		LSB		
AD5313									
Resolution		10		10			Bits		Guaranteed monotonic by design over all codes
Relative Accuracy		$\pm 0.5$	$\pm 4$	$\pm 0.5$	$\pm 2$		LSB		
Differential Nonlinearity		$\pm 0.05$	$\pm 0.5$	$\pm 0.05$	$\pm 0.5$		LSB		
AD5323									
Resolution		12		12			Bits	Guaranteed monotonic by design over all codes	
Relative Accuracy		$\pm 2$	$\pm 16$	$\pm 2$	$\pm 8$		LSB		
Differential Nonlinearity		$\pm 0.2$	$\pm 1$	$\pm 0.2$	$\pm 1$		LSB		
Offset Error		$\pm 0.4$	$\pm 3$	$\pm 0.4$	$\pm 3$		% of FSR	See Figure 2 and Figure 3	
Gain Error		$\pm 0.15$	$\pm 1$	$\pm 0.15$	$\pm 1$		% of FSR	See Figure 2 and Figure 3	
Lower Dead Band		10	60	10	60		mV	See Figure 2 and Figure 3	
Offset Error Drift <sup>5</sup>		-12		-12			ppm of FSR/ $^{\circ}\text{C}$		
Gain Error Drift <sup>5</sup>		-5		-5			ppm of FSR/ $^{\circ}\text{C}$		
Power Supply Rejection Ratio <sup>5</sup>		-60		-60			dB	$\Delta V_{DD} = \pm 10\%$	
DC Crosstalk <sup>5</sup>		30		30			$\mu\text{V}$		
DAC REFERENCE INPUTS <sup>5</sup>									
$V_{REF}$ Input Range	1		$V_{DD}$	1		$V_{DD}$	V	Buffered reference mode	
	0		$V_{DD}$	0		$V_{DD}$	V	Unbuffered reference mode	
$V_{REF}$ Input Impedance		>10			>10		M $\Omega$	Buffered reference mode	
		180			180		k $\Omega$	Unbuffered reference mode	
		90			90		k $\Omega$	0 V to $V_{REF}$ output range, input impedance = $R_{DAC}$	
Reference Feedthrough		-90		-90			dB	Unbuffered reference mode	
Channel-to-Channel Isolation		-80		-80			dB	0 V to $2 V_{REF}$ output range, input impedance = $R_{DAC}$	
OUTPUT CHARACTERISTICS <sup>5</sup>									
Minimum Output Voltage <sup>6</sup>		0.001		0.001			V min	This is a measure of the minimum and maximum drive capability of the output amplifier	
Maximum Output Voltage <sup>6</sup>		$V_{DD} - 0.001$		$V_{DD} - 0.001$			V max		
DC Output Impedance		0.5		0.5			$\Omega$		
Short-Circuit Current		50		50			mA	$V_{DD} = 5\text{ V}$	
		20		20			mA	$V_{DD} = 3\text{ V}$	
Power-Up Time		2.5		2.5			$\mu\text{s}$	Coming out of power-down mode; $V_{DD} = 5\text{ V}$	
		5		5			$\mu\text{s}$	Coming out of power-down mode; $V_{DD} = 3\text{ V}$	

# AD5303/AD5313/AD5323

Parameter <sup>2</sup>	A Version <sup>1</sup>			B Version <sup>1</sup>			Unit	Conditions/Comments
	Min	Typ	Max	Min	Typ	Max		
LOGIC INPUTS <sup>5</sup>								
Input Current			±1			±1	μA	
Input Low Voltage, V <sub>IL</sub>			0.8			0.8	V	V <sub>DD</sub> = 5 V ± 10%
			0.6			0.6	V	V <sub>DD</sub> = 3 V ± 10%
			0.5			0.5	V	V <sub>DD</sub> = 2.5 V
Input High Voltage, V <sub>IH</sub>	2.4			2.4			V	V <sub>DD</sub> = 5 V ± 10%
	2.1			2.1			V	V <sub>DD</sub> = 3 V ± 10%
	2.0			2.0			V	V <sub>DD</sub> = 2.5 V
Pin Capacitance		2	3.5		2	3.5	pF	
LOGIC OUTPUT (SDO) <sup>5</sup>								
V <sub>DD</sub> = 5 V ± 10%								
Output Low Voltage			0.4			0.4	V	I <sub>SINK</sub> = 2 mA
Output High Voltage	4.0			4.0			V	I <sub>SOURCE</sub> = 2 mA
V <sub>DD</sub> = 3 V ± 10%								
Output Low Voltage			0.4			0.4	V	I <sub>SINK</sub> = 2 mA
Output High Voltage	2.4			2.4			V	I <sub>SOURCE</sub> = 2 mA
Floating-State Leakage Current			1			1	μA	DCEN = GND
Floating-State Output Capacitance		3			3		pF	DCEN = GND
POWER REQUIREMENTS								
V <sub>DD</sub>	2.5		5.5	2.5		5.5	V	I <sub>DD</sub> specification is valid for all DAC codes
I <sub>DD</sub> (Normal Mode)								Both DACs active and excluding load currents
V <sub>DD</sub> = 4.5 V to 5.5 V		300	450		300	450	μA	Both DACs in unbuffered mode;
V <sub>DD</sub> = 2.5 V to 3.6 V		230	350		230	350	μA	V <sub>IH</sub> = V <sub>DD</sub> and V <sub>IL</sub> = GND; in buffered mode, extra current is typically x μA per DAC, where x = 5 μA + V <sub>REF</sub> /R <sub>DAC</sub>
I <sub>DD</sub> (Full Power-Down)								
V <sub>DD</sub> = 4.5 V to 5.5 V		0.2	1		0.2	1	μA	
V <sub>DD</sub> = 2.5 V to 3.6 V		0.05	1		0.05	1	μA	

<sup>1</sup> Temperature range for Version A, Version B: -40°C to +105°C.

<sup>2</sup> See the Terminology section.

<sup>3</sup> DC specifications tested with the outputs unloaded.

<sup>4</sup> Linearity is tested using a reduced code range: AD5303 (Code 8 to Code 248); AD5313 (Code 28 to Code 995); AD5323 (Code 115 to Code 3981).

<sup>5</sup> Guaranteed by design and characterization, not production tested.

<sup>6</sup> In order for the amplifier output to reach its minimum voltage, offset error must be negative. In order for the amplifier output to reach its maximum voltage, V<sub>REF</sub> = V<sub>DD</sub> and offset plus gain error must be positive.

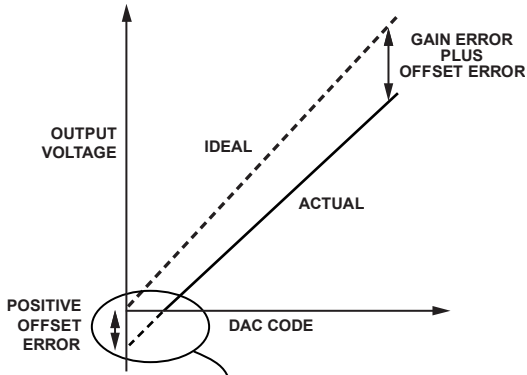

Figure 2. Transfer Function with Negative Offset

00472-005

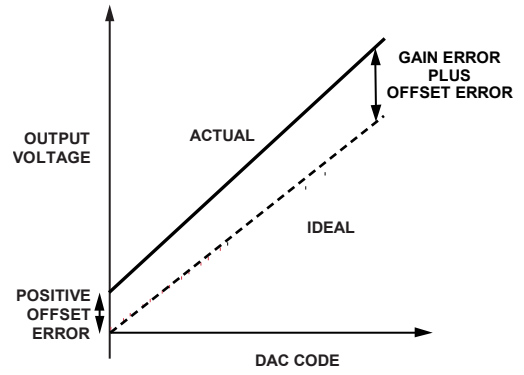

Figure 3. Transfer Function with Positive Offset

00472-006

# AD5303/AD5313/AD5323

## AC CHARACTERISTICS<sup>1</sup>

$V_{DD} = 2.5\text{ V to }5.5\text{ V}$ ;  $R_L = 2\text{ k}\Omega$  to GND;  $C_L = 200\text{ pF}$  to GND; all specifications  $T_{MIN}$  to  $T_{MAX}$ , unless otherwise noted.

Table 2.

Parameter <sup>2</sup>	A, B Version <sup>3</sup>			Unit	Conditions/Comments
	Min	Typ	Max		
Output Voltage Settling Time					$V_{REF} = V_{DD} = 5\text{ V}$
AD5303		6	8	$\mu\text{s}$	1/4 scale to 3/4 scale change (0x40 to 0xc0)
AD5313		7	9	$\mu\text{s}$	1/4 scale to 3/4 scale change (0x100 to 0x300)
AD5323		8	10	$\mu\text{s}$	1/4 scale to 3/4 scale change (0x400 to 0xc00)
Slew Rate		0.7		V/ $\mu\text{s}$	
Major-Code Transition Glitch Energy		12		nV-s	1 LSB change around major carry (011 ... 11 to 100 ... 00)
Digital Feedthrough		0.10		nV-s	
Analog Crosstalk		0.01		nV-s	
DAC-to-DAC Crosstalk		0.01		nV-s	
Multiplying Bandwidth		200		kHz	$V_{REF} = 2\text{ V} \pm 0.1\text{ V}$ p-p, unbuffered mode
Total Harmonic Distortion		-70		dB	$V_{REF} = 2.5\text{ V} \pm 0.1\text{ V}$ p-p, frequency = 10 kHz

<sup>1</sup> Guaranteed by design and characterization, not production tested.

<sup>2</sup> See the Terminology section.

<sup>3</sup> Temperature range for Version A and Version B:  $-40^\circ\text{C}$  to  $+105^\circ\text{C}$ .

## TIMING CHARACTERISTICS

$V_{DD} = 2.5\text{ V to }5.5\text{ V}$ ; all specifications  $T_{MIN}$  to  $T_{MAX}$ , unless otherwise noted.

Table 3.

Parameter <sup>1, 2, 3</sup>	Limit at $T_{MIN}, T_{MAX}$ (A, B Version)	Unit	Conditions/Comments
t <sub>1</sub>	33	ns min	SCLK cycle time
t <sub>2</sub>	13	ns min	SCLK high time
t <sub>3</sub>	13	ns min	SCLK low time
t <sub>4</sub>	0	ns min	$\overline{\text{SYNC}}$ to SCLK rising edge setup time
t <sub>5</sub>	5	ns min	Data setup time
t <sub>6</sub>	4.5	ns min	Data hold time
t <sub>7</sub>	0	ns min	SCLK falling edge to $\overline{\text{SYNC}}$ rising edge
t <sub>8</sub>	100	ns min	Minimum $\overline{\text{SYNC}}$ high time
t <sub>9</sub>	20	ns min	$\overline{\text{LDAC}}$ pulse width
t <sub>10</sub>	20	ns min	SCLK falling edge to $\overline{\text{LDAC}}$ rising edge
t <sub>11</sub>	20	ns min	$\overline{\text{CLR}}$ pulse width
t <sub>12</sub> <sup>4, 5</sup>	5	ns min	SCLK falling edge to SDO invalid
t <sub>13</sub> <sup>4, 5</sup>	20	ns max	SCLK falling edge to SDO valid
t <sub>14</sub> <sup>5</sup>	0	ns min	SCLK falling edge to $\overline{\text{SYNC}}$ rising edge
t <sub>15</sub> <sup>5</sup>	10	ns min	$\overline{\text{SYNC}}$ rising edge to SCLK rising edge

<sup>1</sup> Guaranteed by design and characterization, not production tested.

<sup>2</sup> All input signals are specified with  $t_r = t_f = 5\text{ ns}$  (10% to 90% of  $V_{DD}$ ) and timed from a voltage level of  $(V_{IL} + V_{IH})/2$ .

<sup>3</sup> See Figure 4 and Figure 5.

<sup>4</sup> These are measured with the load circuit of Figure 4.

<sup>5</sup> Daisy-chain mode only (see Figure 47).

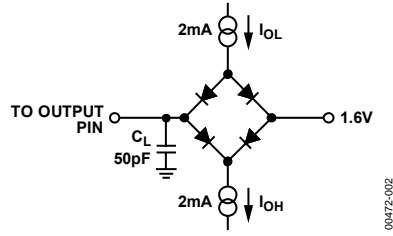
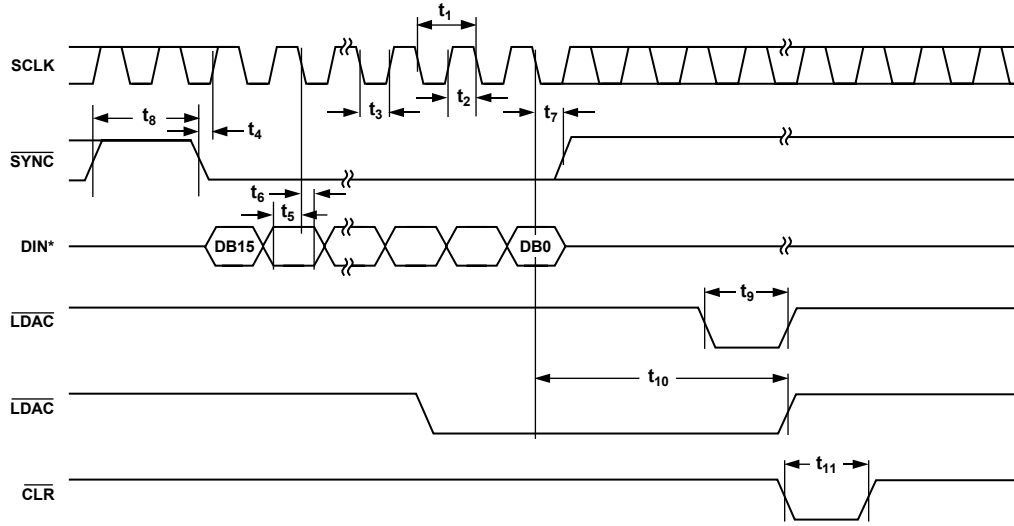

Figure 4. Load Circuit for Digital Output (SDO) Timing Specifications



\*SEE THE INPUT SHIFT REGISTER SECTION.

Figure 5. Serial Interface Timing Diagram

## ABSOLUTE MAXIMUM RATINGS

T<sub>A</sub> = 25°C, unless otherwise noted.<sup>1</sup>

Table 4.

Parameter	Rating
V <sub>DD</sub> to GND	−0.3 V to +7 V
Digital Input Voltage to GND	−0.3 V to V <sub>DD</sub> + 0.3 V
Digital Output Voltage to GND	−0.3 V to V <sub>DD</sub> + 0.3 V
Reference Input Voltage to GND	−0.3 V to V <sub>DD</sub> + 0.3 V
V <sub>OUTA</sub> , V <sub>OUTB</sub> to GND	−0.3 V to V <sub>DD</sub> + 0.3 V
Operating Temperature Range	
Industrial (A, B Version)	−40°C to +105°C
Storage Temperature Range	−65°C to +150°C
Junction Temperature (T <sub>J</sub> Max)	150°C
16-Lead TSSOP Package	
Power Dissipation	(T <sub>J</sub> max − T <sub>A</sub> )/θ <sub>JA</sub>
θ <sub>JA</sub> Thermal Impedance	160°C/W
Lead Temperature	JEDEC Industry Standard
Soldering	J-STD-020

<sup>1</sup> Transient currents of up to 100 mA do not cause SCR latch-up.

Stresses above those listed under Absolute Maximum Ratings may cause permanent damage to the device. This is a stress rating only; functional operation of the device at these or any other conditions above those indicated in the operational section of this specification is not implied. Exposure to absolute maximum rating conditions for extended periods may affect device reliability.

### ESD CAUTION



**ESD (electrostatic discharge) sensitive device.** Charged devices and circuit boards can discharge without detection. Although this product features patented or proprietary protection circuitry, damage may occur on devices subjected to high energy ESD. Therefore, proper ESD precautions should be taken to avoid performance degradation or loss of functionality.

## PIN CONFIGURATION AND FUNCTION DESCRIPTIONS

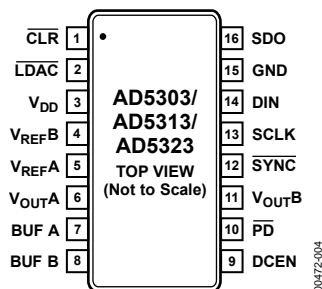

Figure 6. Pin Configuration

Table 5. Pin Function Descriptions

Pin No.	Mnemonic	Description
1	$\overline{\text{CLR}}$	Active Low Control Input. Loads all zeros to both input and DAC registers.
2	$\overline{\text{LDAC}}$	Active Low Control Input. Transfers the contents of the input registers to their respective DAC registers. Pulsing this pin low allows either or both DAC registers to be updated if the input registers have new data. This allows the simultaneous update of both DAC outputs.
3	$V_{\text{DD}}$	Power Supply Input. These parts can be operated from 2.5 V to 5.5 V, and the supply should be decoupled to GND.
4	$V_{\text{REFB}}$	Reference Input Pin for DAC B. It may be configured as a buffered or an unbuffered input, depending on the state of the BUF B pin. It has an input range from 0 V to $V_{\text{DD}}$ in unbuffered mode and from 1 V to $V_{\text{DD}}$ in buffered mode.
5	$V_{\text{REFA}}$	Reference Input Pin for DAC A. It may be configured as a buffered or an unbuffered input depending on the state of the BUF A pin. It has an input range from 0 to $V_{\text{DD}}$ in unbuffered mode and from 1 V to $V_{\text{DD}}$ in buffered mode.
6	$V_{\text{OUTA}}$	Buffered Analog Output Voltage from DAC A. The output amplifier has rail-to-rail operation.
7	BUF A	Control Pin. Controls whether the reference input for DAC A is unbuffered or buffered. If this pin is tied low, the reference input is unbuffered. If it is tied high, the reference input is buffered.
8	BUF B	Control Pin. Controls whether the reference input for DAC B is unbuffered or buffered. If this pin is tied low, the reference input is unbuffered. If it is tied high, the reference input is buffered.
9	DCEN	This pin is used to enable the daisy-chaining option. This should be tied high if the part is being used in a daisy chain. The pin should be tied low if it is being used in standalone mode.
10	$\overline{\text{PD}}$	Active Low Control Input. Acts as a hardware power-down option. This pin overrides any software power-down option. Both DACs go into power-down mode when this pin is tied low. The DAC outputs go into a high impedance state and the current consumption of the part drops to 200 nA @ 5 V (50 nA @ 3 V).
11	$V_{\text{OUTB}}$	Buffered Analog Output Voltage from DAC B. The output amplifier has rail-to-rail operation.
12	$\overline{\text{SYNC}}$	Active Low Control Input. This is the frame synchronization signal for the input data. When $\overline{\text{SYNC}}$ goes low, it powers on the SCLK and DIN buffers and enables the input shift register. Data is transferred in on the falling edges of the following 16 clocks. If SYNC is taken high before the 16th falling edge, the rising edge of SYNC acts as an interrupt and the write sequence is ignored by the device.
13	SCLK	Serial Clock Input. Data is clocked into the input shift register on the falling edge of the serial clock input. Data can be transferred at rates up to 30 MHz. The SCLK input buffer is powered down after each write cycle.
14	DIN	Serial Data Input. This device has a 16-bit shift register. Data is clocked into the register on the falling edge of the serial clock input. The DIN input buffer is powered down after each write cycle.
15	GND	Ground Reference Point for All Circuitry on the Part.
16	SDO	Serial Data Output. Can be used for daisy-chaining a number of these devices together or for reading back the data in the shift register for diagnostic purposes. The serial data output is valid on the falling edge of the clock.

## TERMINOLOGY

### Relative Accuracy or Integral Nonlinearity (INL)

For the DAC, relative accuracy or integral nonlinearity is a measure of the maximum deviation, in LSB, from a straight line passing through the actual endpoints of the DAC transfer function. A typical INL error vs. code plot can be seen in Figure 7, Figure 8, and Figure 9.

### Differential Nonlinearity (DNL)

Differential nonlinearity is the difference between the measured change and the ideal 1 LSB change between any two adjacent codes. A specified DNL of  $\pm 1$  LSB maximum ensures monotonicity. This DAC is guaranteed monotonic by design. A typical DNL error vs. code plot can be seen in Figure 10, Figure 11, and Figure 12.

### Offset Error

This is a measure of the offset error of the DAC and the output amplifier. It is expressed as a percentage of the full-scale range.

### Gain Error

This is a measure of the span error of the DAC. It is the deviation in slope of the actual DAC transfer characteristic from the ideal expressed as a percentage of the full-scale range.

### Offset Error Drift

This is a measure of the change in offset error with changes in temperature. It is expressed in (ppm of full-scale range)/ $^{\circ}\text{C}$ .

### Gain Error Drift

This is a measure of the change in gain error with changes in temperature. It is expressed in (ppm of full-scale range)/ $^{\circ}\text{C}$ .

### Major-Code Transition Glitch Energy

Major-code transition glitch energy is the energy of the impulse injected into the analog output when the code in the DAC register changes state. It is normally specified as the area of the glitch in nV-s and is measured when the digital code is changed by 1 LSB at the major carry transition (011 . . . 11 to 100 . . . 00 or 100 . . . 00 to 011 . . . 11).

### Digital Feedthrough

Digital feedthrough is a measure of the impulse injected into the analog output of the DAC from the digital input pins of the device, but is measured when the DAC is not being written to (SYNC held high). It is specified in nV-s and is measured with a full-scale change on the digital input pins, that is, from all 0s to all 1s and vice versa.

### Analog Crosstalk

This is the glitch impulse transferred to the output of one DAC due to a change in the output of the other DAC. It is measured by loading one of the input registers with a full-scale code change (all 0s to all 1s and vice versa) while keeping  $\overline{\text{LDAC}}$  high. Then pulse  $\overline{\text{LDAC}}$  low and monitor the output of the DAC whose digital code was not changed. The area of the glitch is expressed in nV-s.

### DAC-to-DAC Crosstalk

This is the glitch impulse transferred to the output of one DAC due to a digital code change and subsequent output change of the other DAC. This includes both digital and analog crosstalk. It is measured by loading one of the DACs with a full-scale code change (all 0s to all 1s and vice versa) while keeping  $\overline{\text{LDAC}}$  low and monitoring the output of the other DAC. The area of the glitch is expressed in nV-s.

### DC Crosstalk

This is the dc change in the output level of one DAC in response to a change in the output of the other DAC. It is measured with a full-scale output change on one DAC while monitoring the other DAC. It is expressed in microvolts.

### Power Supply Rejection Ratio (PSRR)

This indicates how the output of the DAC is affected by changes in the supply voltage. PSRR is the ratio of the change in  $V_{\text{OUT}}$  to a change in  $V_{\text{DD}}$  for full-scale output of the DAC. It is measured in decibels.  $V_{\text{REF}}$  is held at 2 V and  $V_{\text{DD}}$  is varied  $\pm 10\%$ .

### Reference Feedthrough

This is the ratio of the amplitude of the signal at the DAC output to the reference input when the DAC output is not being updated (that is,  $\overline{\text{LDAC}}$  is high). It is expressed in decibels.

### Total Harmonic Distortion (THD)

This is the difference between an ideal sine wave and its attenuated version using the DAC. The sine wave is used as the reference for the DAC and the THD is a measure of the harmonics present on the DAC output. It is measured in decibels.

### Multiplying Bandwidth

The amplifiers within the DAC have a finite bandwidth. The multiplying bandwidth is a measure of this. A sine wave on the reference (with full-scale code loaded to the DAC) appears on the output. The multiplying bandwidth is the frequency at which the output amplitude falls to 3 dB below the input.

### Channel-To-Channel Isolation

This is a ratio of the amplitude of the signal at the output of one DAC to a sine wave on the reference input of the other DAC. It is measured in decibels.

# TYPICAL PERFORMANCE CHARACTERISTICS

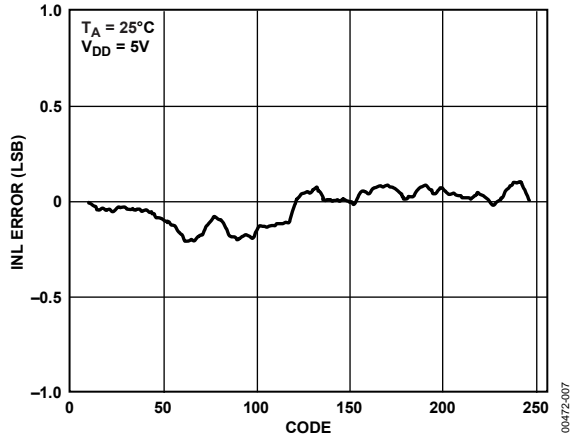

Figure 7. AD5303 Typical INL Plot

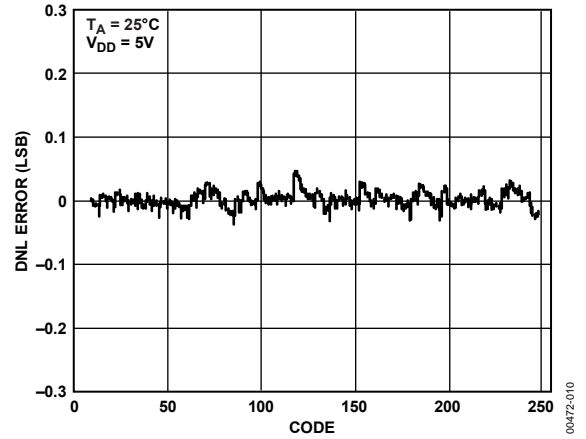

Figure 10. AD5303 Typical DNL Plot

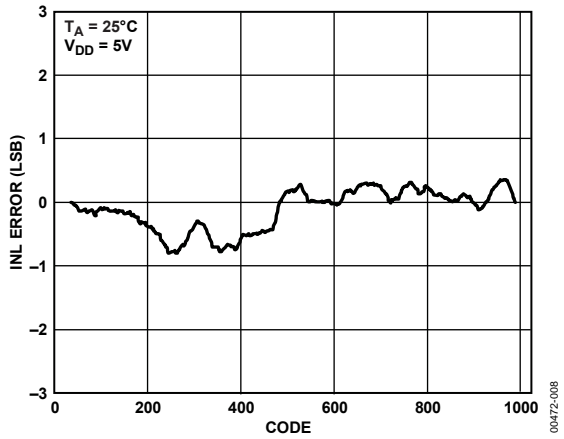

Figure 8. AD5313 Typical INL Plot

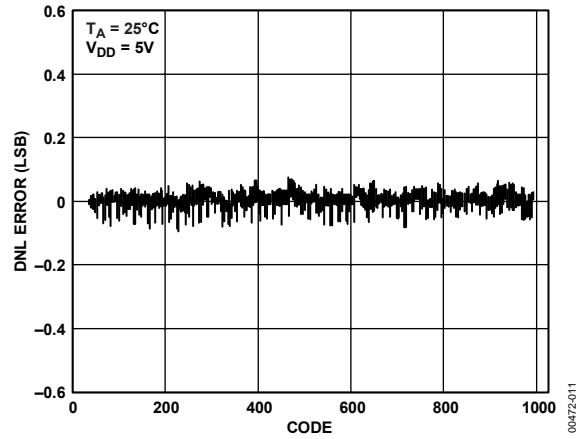

Figure 11. AD5313 Typical DNL Plot

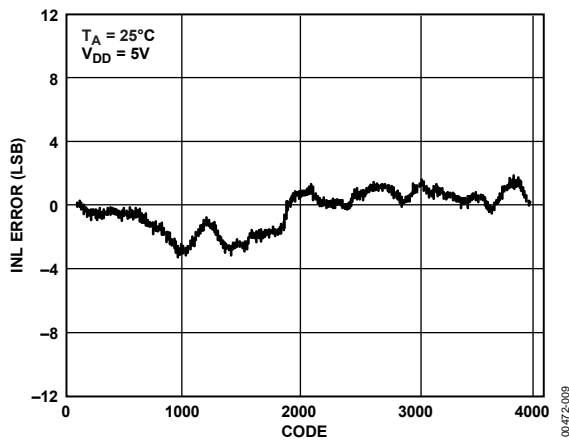

Figure 9. AD5323 Typical INL Plot

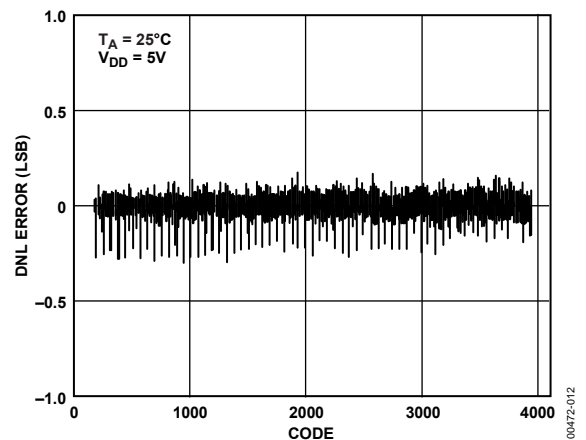

Figure 12. AD5323 Typical DNL Plot

# AD5303/AD5313/AD5323

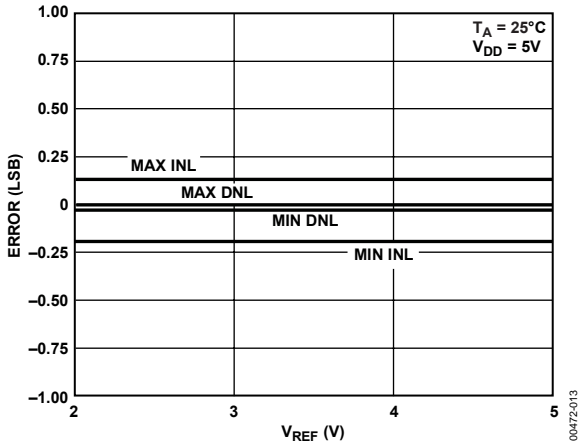

Figure 13. AD5303 INL and DNL Error vs.  $V_{REF}$

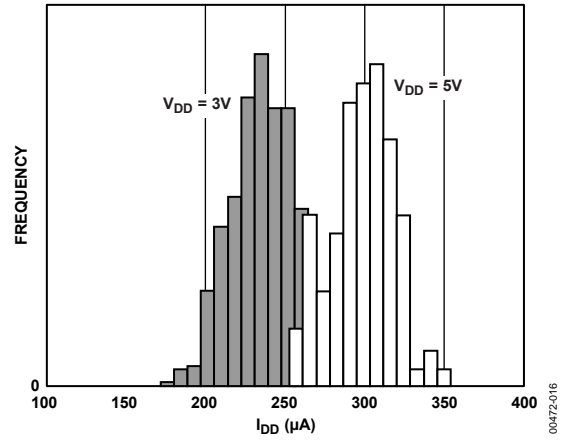

Figure 16.  $I_{DD}$  Histogram with  $V_{DD} = 3V$  and  $V_{DD} = 5V$

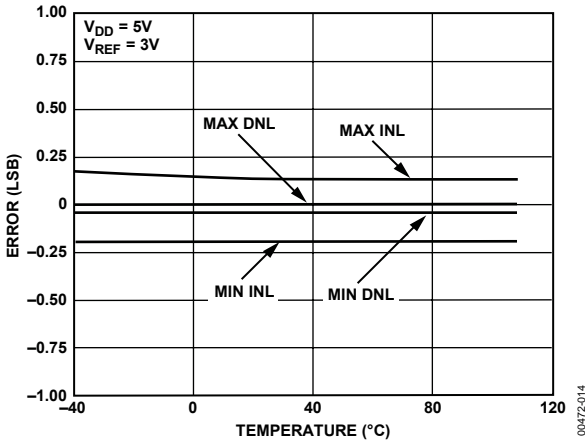

Figure 14. AD5303 INL Error and DNL Error vs. Temperature

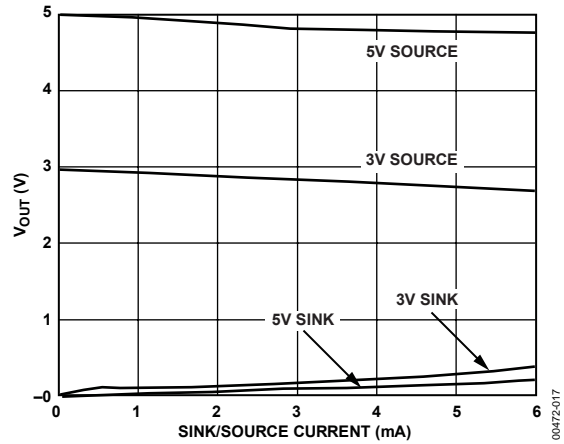

Figure 17. Source and Sink Current Capability

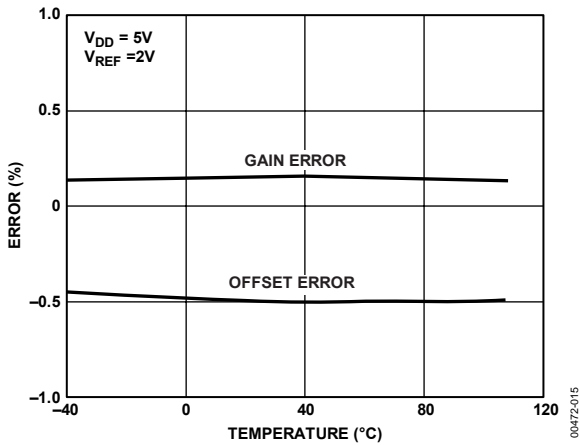

Figure 15. Offset Error and Gain Error vs. Temperature

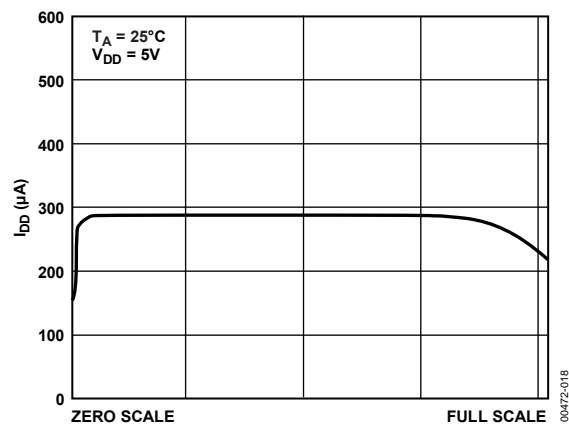

Figure 18. Supply Current vs. Code

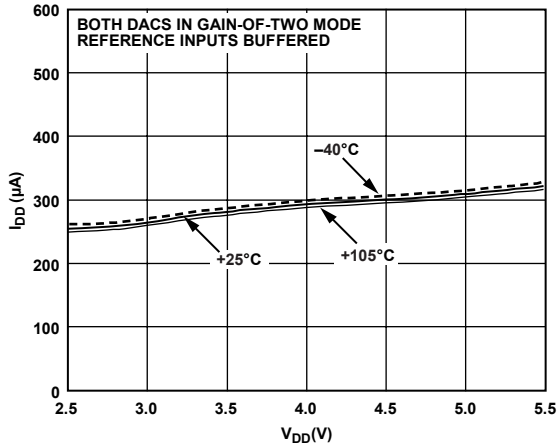

Figure 19. Supply Current vs. Supply Voltage

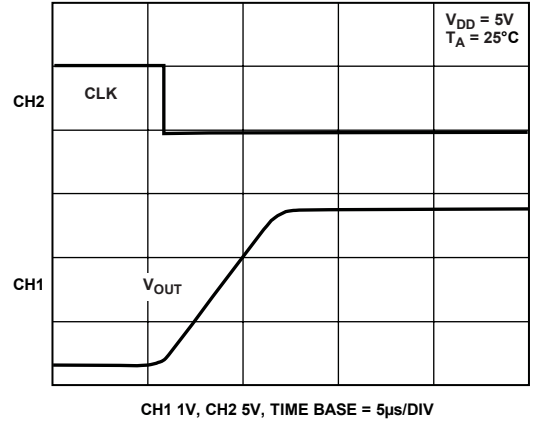

Figure 22. Half-Scale Settling ( $\frac{1}{4}$  to  $\frac{3}{4}$  Scale Code Change)

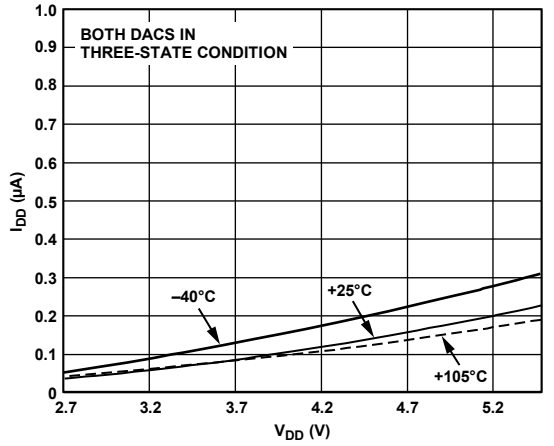

Figure 20. Power-Down Current vs. Supply Voltage

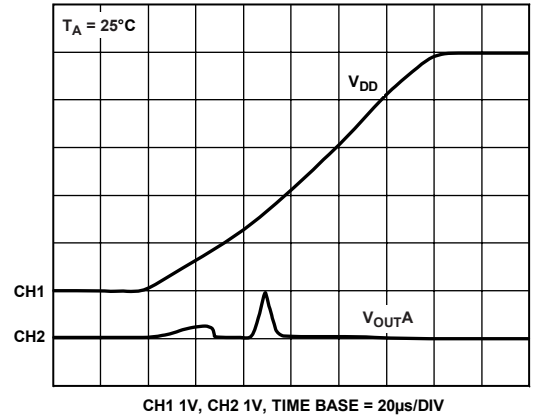

Figure 23. Power-On Reset to 0 V

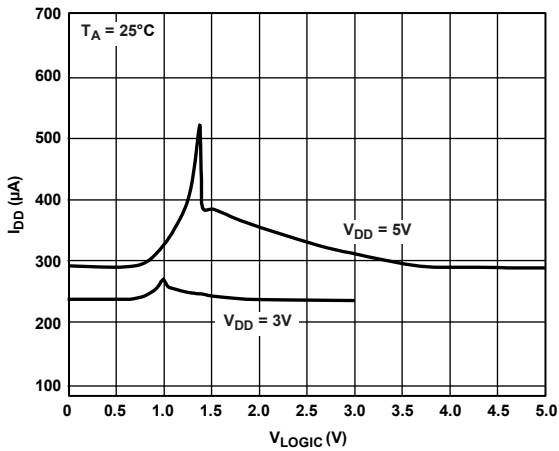

Figure 21. Supply Current vs. Logic Input Voltage

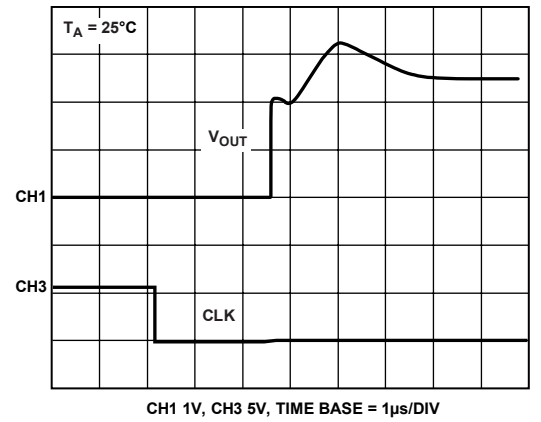

Figure 24. Exiting Power-Down to Midscale

# AD5303/AD5313/AD5323

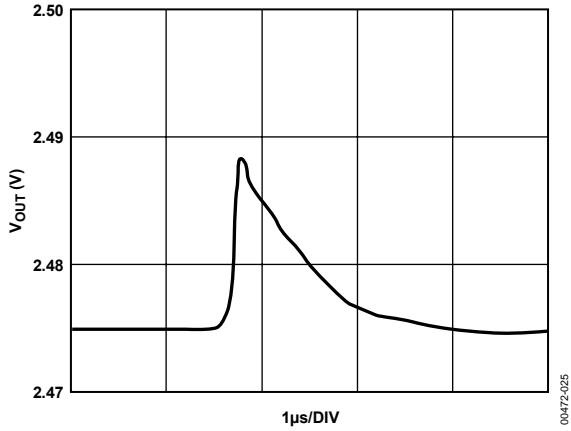

Figure 25. AD5323 Major-Code Transition

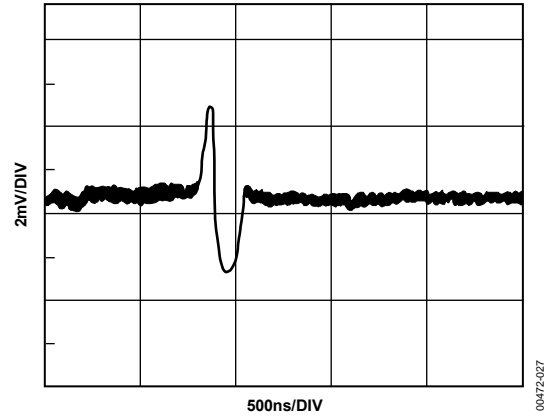

Figure 27. DAC-to-DAC Crosstalk

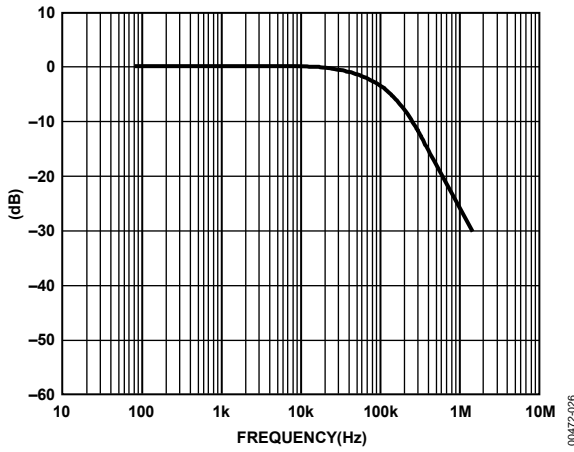

Figure 26. Multiplying Bandwidth (Small-Signal Frequency Response)

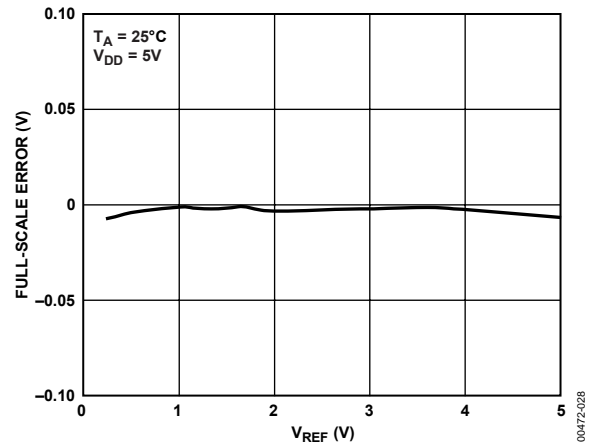

Figure 28. Full-Scale Error vs.  $V_{REF}$  (Buffered)

## FUNCTIONAL DESCRIPTION

The AD5303/AD5313/AD5323 are dual resistor-string DACs fabricated on a CMOS process with resolutions of 8-/10-/12-bits respectively. They contain reference buffers and output buffer amplifiers, and are written to via a 3-wire serial interface. They operate from single supplies of 2.5 V to 5.5 V and the output buffer amplifiers provide rail-to-rail output swing with a slew rate of 0.7 V/ $\mu$ s. Each DAC is provided with a separate reference input, which may be buffered to draw virtually no current from the reference source, or unbuffered to give a reference input range from GND to  $V_{DD}$ . The devices have three programmable power-down modes, in which one or both DACs may be turned off completely with a high impedance output, or the output may be pulled low by an on-chip resistor.

### DIGITAL-TO-ANALOG

The architecture of one DAC channel consists of a reference buffer and a resistor-string DAC followed by an output buffer amplifier. The voltage at the  $V_{REF}$  pin provides the reference voltage for the DAC. Figure 29 shows a block diagram of the DAC architecture. Because the input coding to the DAC is straight binary, the ideal output voltage is given by

$$V_{OUT} = \frac{V_{REF} \times D}{2^N}$$

where:

$D$  is the decimal equivalent of the binary code, which is loaded to the DAC register:

- 0 to 255 for AD5303 (8 bits)
- 0 to 1023 for AD5313 (10 bits)
- 0 to 4095 for AD5323 (12 bits)

$N$  is the DAC resolution.

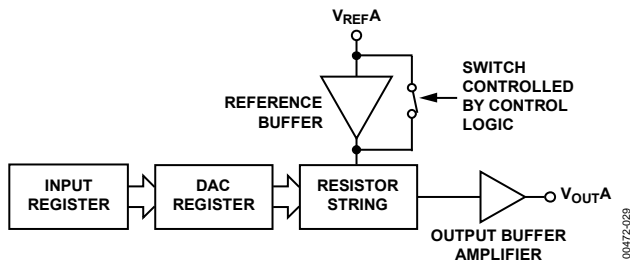

Figure 29. Single DAC Channel Architecture

### RESISTOR STRING

The resistor string section of the AD5303/AD5313/AD5323 is shown in Figure 30. It is simply a string of resistors, each of value  $R$ . The digital code loaded to the DAC register determines at what node on the string the voltage is tapped off to be fed into the output amplifier. The voltage is tapped off by closing one of the switches connecting the string to the amplifier. Because it is a string of resistors, it is guaranteed monotonic.

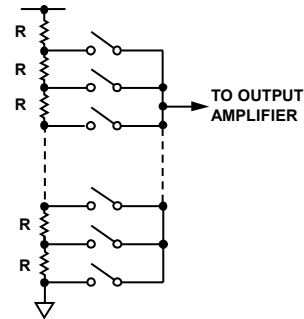

Figure 30. Resistor String

### DAC REFERENCE INPUTS

There is a reference input pin for each of the two DACs. The reference inputs are buffered, but can also be configured as unbuffered. The advantage with the buffered input is the high impedance it presents to the voltage source driving it. However, if the unbuffered mode is used, the user can have a reference voltage as low as GND and as high as  $V_{DD}$  since there is no restriction due to headroom and footroom of the reference amplifier.

If there is a buffered reference in the circuit (for example, REF192), there is no need to use the on-chip buffers of the AD5303/AD5313/AD5323. In unbuffered mode, the input impedance is still large at typically 180 k $\Omega$  per reference input for 0 V to  $V_{REF}$  mode and 90 k $\Omega$  for 0 V to 2  $V_{REF}$  mode.

The buffered/unbuffered option is controlled by the BUF A and BUF B pins. If a BUF pin is tied high, the reference input is buffered; if tied low, it is unbuffered.

### OUTPUT AMPLIFIER

The output buffer amplifier is capable of generating output voltages to within 1 mV of either rail, which gives an output range of 0.001 V to  $V_{DD} - 0.001$  V when the reference is  $V_{DD}$ . It is capable of driving a load of 2 k $\Omega$  in parallel with 500 pF to GND and  $V_{DD}$ . The source and sink capabilities of the output amplifier can be seen in Figure 17.

The slew rate is 0.7 V/ $\mu$ s with a half-scale settling time to  $\pm 0.5$  LSB (at eight bits) of 6  $\mu$ s.

## POWER-ON RESET

The AD5303/AD5313/AD5323 are provided with a power-on reset function, so that they power up in a defined state. The power-on state is with 0V to  $V_{REF}$  output range and the output set to 0 V.

Both input and DAC registers are filled with zeros and remain so until a valid write sequence is made to the device. This is

particularly useful in applications where it is important to know the state of the DAC outputs while the device is powering up.

## CLEAR FUNCTION ( $\overline{CLR}$ )

The  $\overline{CLR}$  pin is an active low input that, when pulled low, loads all zeros to both input registers and both DAC registers. This enables both analog outputs to be cleared to 0 V.

## SERIAL INTERFACE

The AD5303/AD5313/AD5323 are controlled over a versatile, 3-wire serial interface, which operates at clock rates up to 30 MHz and is compatible with SPI, QSPI, MICROWIRE, and DSP interface standards.

### INPUT SHIFT REGISTER

The input shift register is 16 bits wide. Data is loaded into the device as a 16-bit word under the control of a serial clock input, SCLK. The timing diagram for this operation is shown in Figure 5. The 16-bit word consists of four control bits followed by 8 /10 /12 bits of DAC data, depending on the device type. The first bit loaded is the MSB (Bit 15), which determines whether the data is for DAC A or DAC B. Bit 14 determines the output range (0 V to  $V_{REF}$  or 0 V to  $2 V_{REF}$ ). Bit 13 and Bit 12 control the operating mode of the DAC.

**Table 6. Control Bits**

Bit	Name	Function	Power-On Default
15	A/B	0: data written to DAC A 1: data written to DAC B	N/A
14	GAIN	0: output range of 0 V to $V_{REF}$ 1: output range of 0 V to $2 V_{REF}$	0
13	PD1	Mode bit	0
12	PD0	Mode bit	0

The remaining bits are DAC data bits, starting with the MSB and ending with the LSB. The AD5323 uses all 12 bits of DAC data; the AD5313 uses 10 bits and ignores the 2 LSBs. The AD5303 uses eight bits and ignores the last four bits. The data format is straight binary, with all 0s corresponding to 0 V output, and all 1s corresponding to full-scale output ( $V_{REF} - 1 \text{ LSB}$ ).

The  $\overline{\text{SYNC}}$  input is a level-triggered input that acts as a frame synchronization signal and  $\overline{\text{chip enable}}$ . Data can be transferred into the device only while  $\overline{\text{SYNC}}$  is low. To start the serial data transfer,  $\overline{\text{SYNC}}$  should be taken low, observing the minimum  $\overline{\text{SYNC}}$  to SCLK rising edge setup time,  $t_4$ . After  $\overline{\text{SYNC}}$  goes low, serial data is shifted into the device's input shift register on the falling edges of SCLK for 16 clock pulses. Any data and clock pulses after the 16th are ignored, and no further serial data transfer occurs until  $\overline{\text{SYNC}}$  is taken high and low again.

$\overline{\text{SYNC}}$  may be taken high after the falling edge of the 16th SCLK pulse, observing the minimum SCLK falling edge to  $\overline{\text{SYNC}}$  rising edge time,  $t_7$ .

After the end of serial data transfer, data is automatically transferred from the input shift register to the input register of the selected DAC. If  $\overline{\text{SYNC}}$  is taken high before the 16th falling edge of SCLK, the data transfer is aborted and the input registers are not updated.

When data has been transferred into both input registers, the DAC registers of both DACs may be simultaneously updated, by taking  $\overline{\text{LDAC}}$  low.  $\overline{\text{CLR}}$  is an active low, asynchronous clear that clears the input and DAC registers of both DACs to all 0s.

### LOW POWER SERIAL INTERFACE

To reduce the power consumption of the device even further, the interface only powers up fully when the device is being written to. As soon as the 16-bit control word has been written to the part, the SCLK and DIN input buffers are powered down. They only power up again following a falling edge of  $\overline{\text{SYNC}}$ .

### DOUBLE-BUFFERED INTERFACE

The DACs all have double-buffered interfaces consisting of two banks of registers—input registers and DAC registers. The input register is connected directly to the input shift register and the digital code is transferred to the relevant input register on completion of a valid write sequence. The DAC register contains the digital code used by the resistor string.

Access to the DAC register is controlled by the  $\overline{\text{LDAC}}$  function. When  $\overline{\text{LDAC}}$  is high, the DAC register is latched and the input register may change state without affecting the contents of the DAC register. However, when  $\overline{\text{LDAC}}$  is brought low, the DAC register becomes transparent and the contents of the input register are transferred to it.

This is useful if the user requires simultaneous updating of both DAC outputs. The user may write to both input registers individually and then, by pulsing the  $\overline{\text{LDAC}}$  input low, both outputs update simultaneously.

These parts contain an extra feature whereby the DAC register is not updated unless its input register has been updated since the last time that  $\overline{\text{LDAC}}$  was brought low. Normally, when  $\overline{\text{LDAC}}$  is brought low, the DAC registers are filled with the contents of the input registers. In the case of the AD5303/AD5313/AD5323, the part only updates the DAC register if the input register has been changed since the last time the DAC register was updated, thereby removing unnecessary digital crosstalk.

# AD5303/AD5313/AD5323

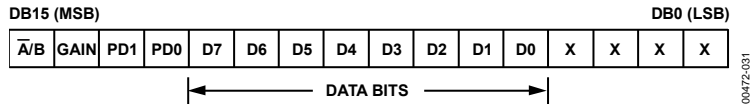

Figure 31. AD5303 Input Shift Register Contents

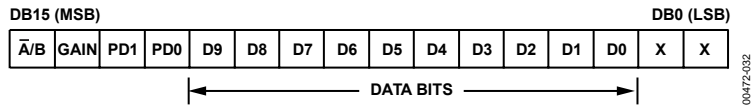

Figure 32. AD5313 Input Shift Register Contents

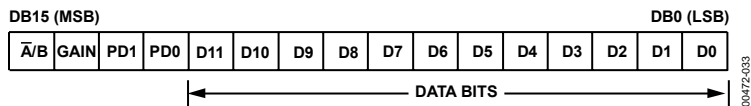

Figure 33. AD5323 Input Shift Register Contents

## POWER-DOWN MODES

The AD5303/AD5313/AD5323 have very low power consumption, dissipating only 0.7 mW with a 3 V supply and 1.5 mW with a 5 V supply. Power consumption can be further reduced when the DACs are not in use by putting them into one of three power-down modes, which are selected by Bit 13 and Bit 12 (PD1 and PD0) of the control word. Table 7 shows how the state of the bits corresponds to the mode of operation of that particular DAC.

**Table 7. PD1/PD0 Operating Modes**

PD1	PD0	Operating Mode
0	0	Normal operation
0	1	Power-down (1 k $\Omega$ load to GND)
1	0	Power-down (100 k $\Omega$ load to GND)
1	1	Power-down (high impedance output)

When both bits are set to 0, the DACs work normally with their normal power consumption of 300  $\mu$ A at 5 V. However, for the three power-down modes, the supply current falls to 200 nA at 5 V (50 nA at 3 V) when both DACs are powered down. Not only does the supply current drop, but the output stage is also internally switched from the output of the amplifier to a resistor network of known values. This has the advantage that the output impedance of the part is known while the part is in power-down mode and provides a defined input condition for whatever is connected to the output of the DAC amplifier.

There are three different power-down options. The output is connected internally to GND through either a 1 k $\Omega$  resistor or a 100 k $\Omega$  resistor, or it is left in a high impedance state (three-state). The output stage is illustrated in Figure 34.

The bias generator, the output amplifier, the resistor string, and all other associated linear circuitry are shut down when the power-down mode is activated. However, the contents of the registers are unaffected when in power-down. The time to exit power-down is typically 2.5  $\mu$ s for  $V_{DD} = 5$  V and 5  $\mu$ s when  $V_{DD} = 3$  V (see Figure 24 for a plot).

The software power-down modes programmed by PD0 and PD1 are overridden by the  $\overline{PD}$  pin. Taking this pin low puts both DACs into power-down mode simultaneously and both outputs are put into a high impedance state. If  $\overline{PD}$  is not used, it should be tied high.

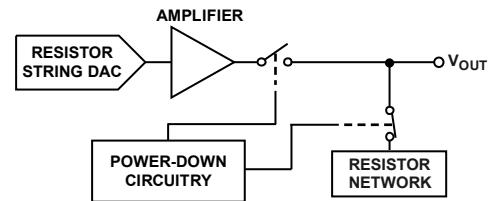

Figure 34. Output Stage During Power-Down

# AD5303/AD5313/AD5323

## MICROPROCESSOR INTERFACING

### AD5303/AD5313/AD5323 TO ADSP-2101 INTERFACE

Figure 35 shows a serial interface between the AD5303/AD5313/AD5323 and the ADSP-2101. The ADSP-2101 should be set up to operate in the SPORT transmit alternate framing mode. The ADSP-2101 sport is programmed through the SPORT control register and should be configured as follows: internal clock operation, active-low framing, 16-bit word length. Transmission is initiated by writing a word to the Tx register after the SPORT has been enabled.

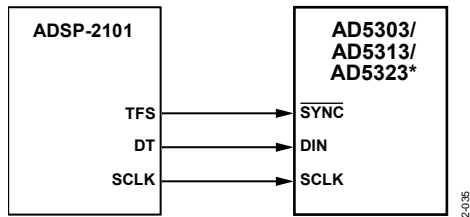

\*ADDITIONAL PINS OMITTED FOR CLARITY

00472-035

Figure 35. AD5303/AD5313/AD5323 to ADSP-2101 Interface

### AD5303/AD5313/AD5323 TO 68HC11/68L11 INTERFACE

Figure 36 shows a serial interface between the AD5303/AD5313/AD5323 and the 68HC11/68L11 microcontroller. SCK of the 68HC11/68L11 drives the SCLK of the AD5303/AD5313/AD5323, while the MOSI output drives the serial data line (DIN) of the DAC. The SYNC signal is derived from a port line (PC7). The setup conditions for correct operation of this interface are as follows: the 68HC11/68L11 should be configured so that its CPOL bit is a 0 and its CPHA bit is a 1. When data is being transmitted to the DAC, the SYNC line is taken low (PC7). When the 68HC11/68L11 is configured as previously mentioned, data appearing on the MOSI output is valid on the falling edge of SCK. Serial data from the 68HC11/68L11 is transmitted in 8-bit bytes with only eight falling clock edges occurring in the transmit cycle. Data is transmitted MSB first. To load data to the AD5303/AD5313/AD5323, PC7 is left low after the first eight bits are transferred and a second serial write operation is performed to the DAC; PC7 is taken high at the end of this procedure.

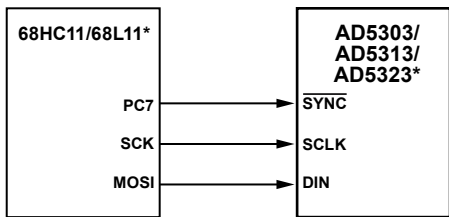

\*ADDITIONAL PINS OMITTED FOR CLARITY

00472-036

Figure 36. AD5303/AD5313/AD5323 to 68HC11/68L11 Interface

### AD5303/AD5313/AD5323 TO 80C51/80L51 INTERFACE

Figure 37 shows a serial interface between the AD5303/AD5313/AD5323 and the 80C51/80L51 microcontroller. The setup for the interface is as follows: TXD of the 80C51/80L51 drives SCLK of the AD5303/AD5313/AD5323, while RXD drives the serial data line of the part. The SYNC signal is again derived from a bit programmable pin on the port. In this case, port line P3.3 is used. When data is to be transmitted to the AD5303/AD5313/AD5323, P3.3 is taken low. The 80C51/80L51 transmits data only in 8-bit bytes; thus only eight falling clock edges occur in the transmit cycle. To load data to the DAC, P3.3 is left low after the first eight bits are transmitted and a second write cycle is initiated to transmit the second byte of data. P3.3 is taken high following the completion of this cycle. The 80C51/80L51 output the serial data in a format that has the LSB first. The AD5303/AD5313/AD5323 require data with MSB as the first bit received. The 80C51/80L51 transmit routine should take this into account.

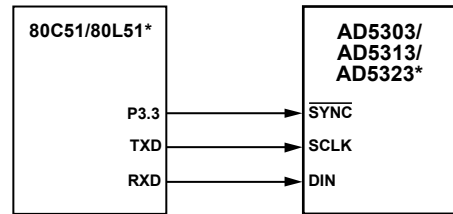

\*ADDITIONAL PINS OMITTED FOR CLARITY.

00472-037

Figure 37. AD5303/AD5313/AD5323 to 80C51/80L51 Interface

### AD5303/AD5313/AD5323 TO MICROWIRE INTERFACE

Figure 38 shows an interface between the AD5303/AD5313/AD5323 and any MICROWIRE-compatible device. Serial data is shifted out on the falling edge of the serial clock and is clocked into the AD5303/AD5313/AD5323 on the rising edge of the SK.

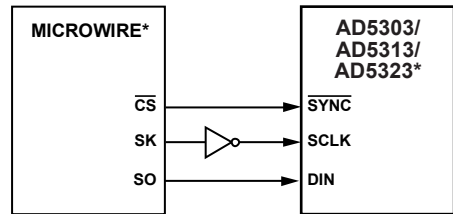

\*ADDITIONAL PINS OMITTED FOR CLARITY.

00472-038

Figure 38. AD5303/AD5313/AD5323 to MICROWIRE Interface

## APPLICATIONS INFORMATION

### TYPICAL APPLICATION CIRCUIT

The AD5303/AD5313/AD5323 can be used with a wide range of reference voltages, especially if the reference inputs are configured to be unbuffered, in which case the devices offer a full, one-quadrant multiplying capability over a reference range of 0 V to  $V_{DD}$ .

More typically, the AD5303/AD5313/AD5323 may be used with a fixed precision reference voltage. Figure 39 shows a typical setup for the AD5303/AD5313/AD5323 when using an external reference. If the reference inputs are unbuffered, the reference input range is from 0 V to  $V_{DD}$ , but if the on-chip reference buffers are used, the reference range is reduced. Suitable references for 5 V operation are the [AD780](#) and [REF192](#) (2.5 V references). For 2.5 V operation, a suitable external reference is the [REF191](#), a 2.048 V reference.

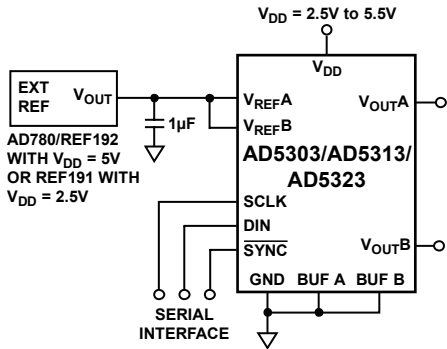

Figure 39. AD5303/AD5313/AD5323 Using External Reference

If an output range of 0 V to  $V_{DD}$  is required when the reference inputs are configured as unbuffered (for example, 0 V to 5 V), the simplest solution is to connect the reference inputs to  $V_{DD}$ . As this supply may not be very accurate and may be noisy, the AD5303/AD5313/AD5323 can be powered from the reference voltage, for example, using a 5 V reference such as the [REF195](#), as shown in Figure 40. The REF195 outputs a steady supply voltage for the AD5303/AD5313/AD5323. The supply current required from the REF195 is 300  $\mu$ A and approximately 30  $\mu$ A or 60  $\mu$ A into each of the reference inputs (if unbuffered). This is with no load on the DAC outputs. When the DAC outputs are loaded, the REF195 also needs to supply the current to the loads. The total current required (with a 10 k $\Omega$  load on each output) is

$$360 \mu\text{A} + 2(5 \text{ V}/10 \text{ k}\Omega) = 1.36 \text{ mA}$$

The load regulation of the REF195 is typically 2 ppm/mA, which results in an error of 2.7 ppm (13.5  $\mu$ V) for the 1.36 mA current drawn from it. This corresponds to a 0.0007 LSB error at eight bits and 0.011 LSB error at 12 bits.

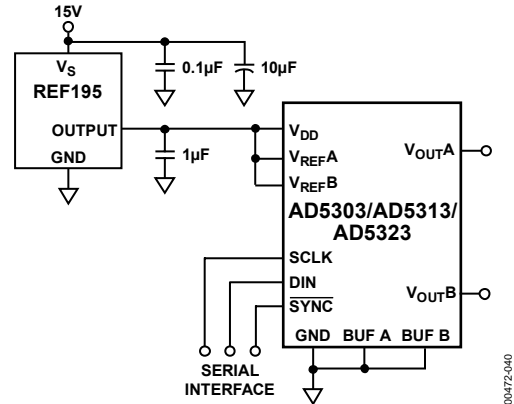

Figure 40. Using an REF195 as Power and Reference to the AD5303/AD5313/AD5323

### BIPOLAR OPERATION USING THE AD5303/AD5313/AD5323

The AD5303/AD5313/AD5323 have been designed for single-supply operation, but bipolar operation is also achievable using the circuit shown in Figure 41. The circuit shown has been configured to achieve an output voltage range of  $-5 \text{ V} < V_{OUT} < +5 \text{ V}$ . Rail-to-rail operation at the amplifier output is achievable using an [AD820](#) or [OP295](#) as the output amplifier.

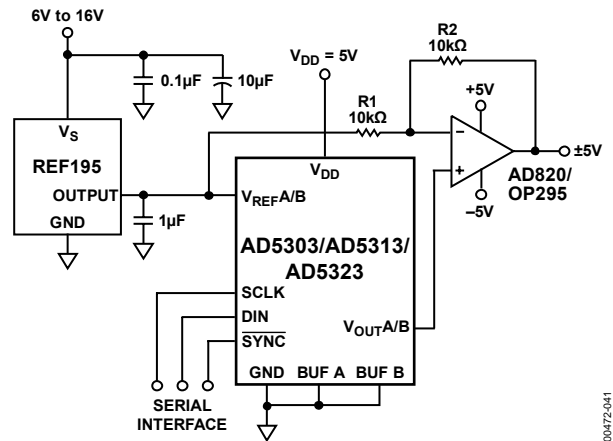

Figure 41. Bipolar Operation Using the AD5303/AD5313/AD5323

The output voltage for any input code can be calculated as follows:

$$V_{OUT} = [(V_{REF}) \times (D / 2^N) \times (R1 + R2) / R1 - V_{REF} \times (R2 / R1)]$$

where:

$D$  is the decimal equivalent of the code loaded to the DAC.

$N$  is the DAC resolution.

$V_{REF}$  is the reference voltage input, and gain bit = 0, with

$$V_{REF} = 5 \text{ V}$$

$$R1 = R2 = 10 \text{ k}\Omega \text{ and } V_{DD} = 5 \text{ V,}$$

$$V_{OUT} = (10 \times D / 2^N) - 5 \text{ V}$$

# AD5303/AD5313/AD5323

## OPTO-ISOLATED INTERFACE FOR PROCESS CONTROL APPLICATIONS

The AD5303/AD5313/AD5323 has a versatile 3-wire serial interface making it ideal for generating accurate voltages in process control and industrial applications. Due to noise, safety requirements, or distance, it may be necessary to isolate the AD5303/AD5313/AD5323 from the controller. This can easily be achieved by using opto-isolators, which provides isolation in excess of 3 kV. The serial loading structure of the AD5303/AD5313/AD5323 makes it ideally suited for use in opto-isolated applications. Figure 42 shows an opto-isolated interface to the AD5303/AD5313/AD5323 where DIN, SCLK, and  $\overline{\text{SYNC}}$  are driven from opto-couplers. The power supply to the part also needs to be isolated. This is done by using a transformer. On the DAC side of the transformer, a 5 V regulator provides the 5 V supply required for the AD5303/AD5313/AD5323.

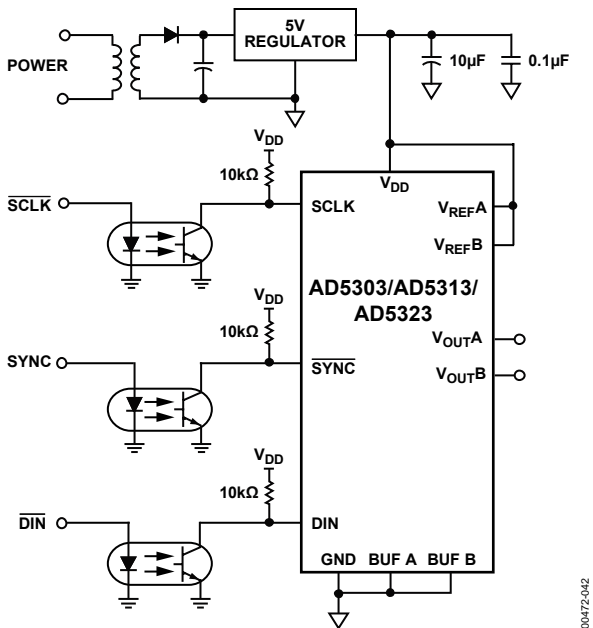

Figure 42. AD5303/AD5313/AD5323 in an Opto-Isolated Interface

## DECODING MULTIPLE AD5303/AD5313/AD5323s

The SYNC pin on the AD5303/AD5313/AD5323 can be used in applications to decode a number of DACs. In this application, all the DACs in the system receive the same serial clock and serial data, but only the  $\overline{\text{SYNC}}$  to one of the devices is active at any one time, allowing access to two channels in this 8-channel system. The 74HC139 is used as a 2-to-4 line decoder to address any of the DACs in the system. To prevent timing errors from occurring, the enable input should be brought to its inactive state while the coded address inputs are changing state. Figure 43 shows a diagram of a typical setup for decoding multiple AD5303/AD5313/AD5323 devices in a system.

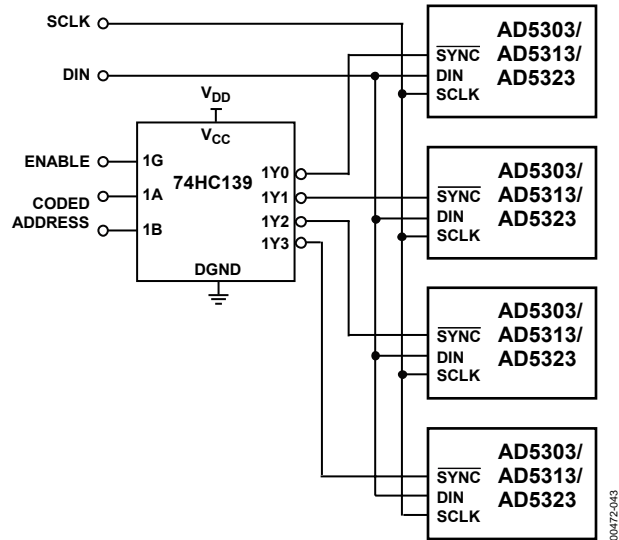

Figure 43. Decoding Multiple AD5303/AD5313/AD5323 Devices in a System

## AD5303/AD5313/AD5323 AS A DIGITALLY PROGRAMMABLE WINDOW DETECTOR

A digitally programmable upper/lower limit detector using the two DACs in the AD5303/AD5313/AD5323 is shown in Figure 44. The upper and lower limits for the test are loaded to DAC A and DAC B, which, in turn, set the limits on the CMP04. If the signal at the  $V_{IN}$  input is not within the programmed window, an LED indicates the fail condition.

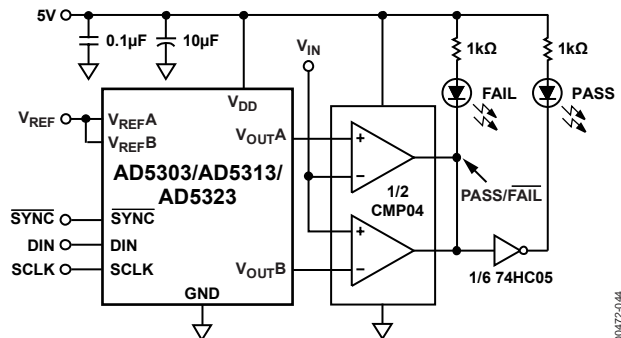

Figure 44. Window Detector Using AD5303/AD5313/AD5323

## COARSE AND FINE ADJUSTMENT USING THE AD5303/AD5313/AD5323

The DACs in the AD5303/AD5313/AD5323 can be paired together to form a coarse and fine adjustment function, as shown in Figure 45. DAC A provides the coarse adjustment while DAC B provides the fine adjustment. Varying the ratio of R1 and R2 changes the relative effect of the coarse and fine adjustments. With the resistor values and external reference shown, the output amplifier has unity gain for the DAC A output, so the output range is 0 V to 2.5 V – 1 LSB. For DAC B, the amplifier has a gain of  $7.6 \times 10^{-3}$ , giving DAC B a range equal to 19 mV.

The circuit is shown with a 2.5 V reference, but reference voltages up to  $V_{DD}$  may be used. The op amps indicated allow a rail-to-rail output swing.

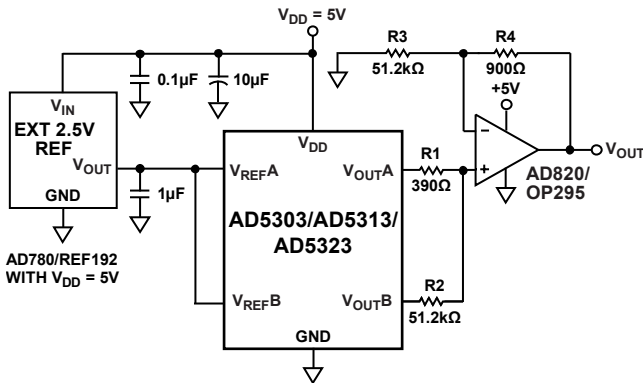

Figure 45. Coarse and Fine Adjustment

## DAISY-CHAIN MODE

This mode is used for updating serially connected or standalone devices on the rising edge of  $\overline{\text{SYNC}}$ . For systems that contain several DACs, or where the user wishes to read back the DAC contents for diagnostic purposes, the SDO pin may be used to daisy-chain several devices together and provide serial readback.

By connecting the daisy-chain enable (DCEN) pin high, the daisy-chain mode is enabled. It is tied low in standalone mode. In daisy-chain mode, the internal gating on SCLK is disabled. The SCLK is continuously applied to the input shift register when  $\overline{\text{SYNC}}$  is low. If more than 16 clock pulses are applied, the data ripples out of the shift register and appears on the SDO line. This data is clocked out after the falling edge of SCLK and is valid on the subsequent rising and falling edges. By connecting this line to the DIN input on the next DAC in the chain, a multiDAC interface is constructed. Sixteen clock pulses are required for each DAC in the system. Therefore, the total number of clock cycles must equal 16N, where N is the total number of devices in the chain. When the serial transfer to all devices is complete,  $\overline{\text{SYNC}}$  should be taken high. This prevents any further data from being clocked into the input shift register.

A continuous SCLK source may be used if it can be arranged that  $\overline{\text{SYNC}}$  is held low for the correct number of clock cycles. Alternatively, a burst clock containing the exact number of clock cycles may be used and  $\overline{\text{SYNC}}$  may be taken high some time later.

When the transfer to all input registers is complete, a common  $\overline{\text{LDAC}}$  signal updates all DAC registers and all analog outputs are updated simultaneously.

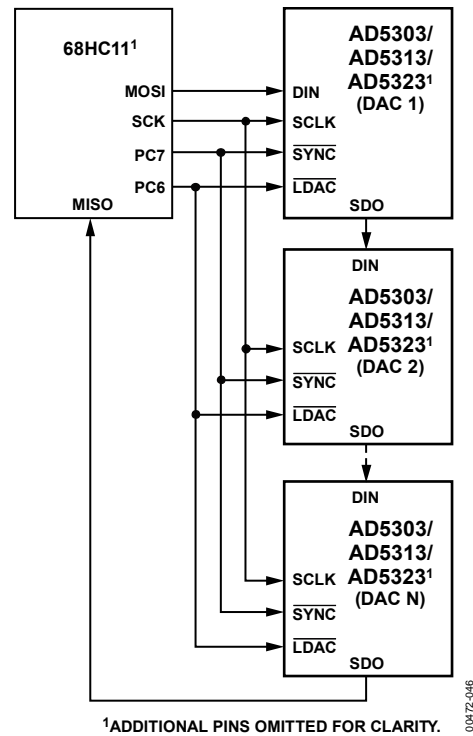

<sup>1</sup>ADDITIONAL PINS OMITTED FOR CLARITY.

Figure 46. Daisy-Chain Mode

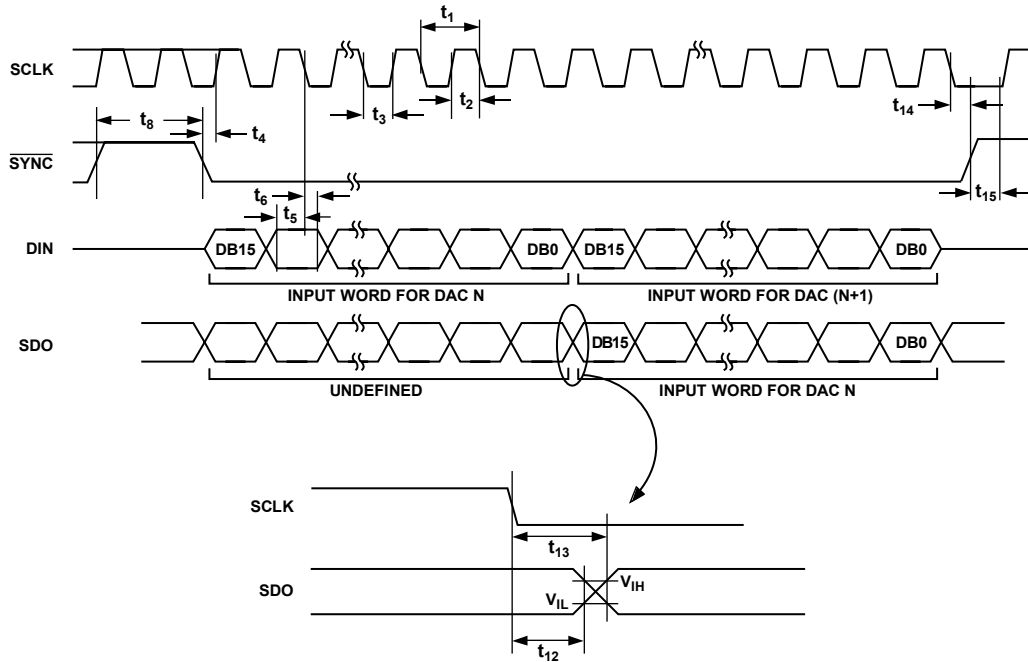

Figure 47. Daisy-Chaining Timing Diagram

00472-047

## POWER SUPPLY BYPASSING AND GROUNDING

In any circuit where accuracy is important, careful consideration of the power supply and ground return layout helps to ensure the rated performance. The printed circuit board on which the AD5303/AD5313/AD5323 are mounted should be designed so that the analog and digital sections are separated and confined to certain areas of the board. If the AD5303/AD5313/AD5323 are in a system where multiple devices require an AGND-to-DGND connection, the connection should be made at one point only. The star ground point should be established as close as possible to the AD5303/AD5313/AD5323. The AD5303/AD5313/AD5323 should have ample supply bypassing of 10  $\mu\text{F}$  in parallel with 0.1  $\mu\text{F}$  on the supply located as close to the package as possible, ideally right up against the device. Use 10  $\mu\text{F}$  capacitors that are of the tantalum bead type. The 0.1  $\mu\text{F}$  capacitor should have low effective series resistance (ESR) and effective series inductance

(ESI), like the common ceramic types that provide a low impedance path to ground at high frequencies to handle transient currents due to internal logic switching.

The power supply lines of the AD5303/AD5313/AD5323 should use as large a trace as possible to provide low impedance paths and reduce the effects of glitches on the power supply line. Fast switching signals such as clocks should be shielded with digital ground to avoid radiating noise to other parts of the board, and should never be run near the reference inputs. Avoid crossover of digital and analog signals. Traces on opposite sides of the board should run at right angles to each other. This reduces the effects of feedthrough through the board. A microstrip technique is by far the best, but is not always possible with a double-sided board. In this technique, the component side of the board is dedicated to the ground plane while signal traces are placed on the solder side.

## OUTLINE DIMENSIONS

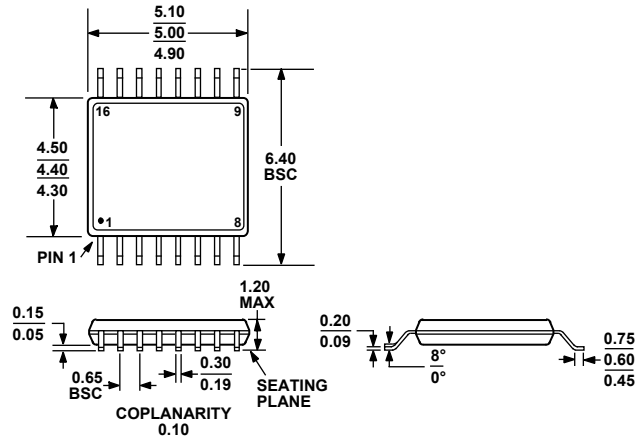

COMPLIANT TO JEDEC STANDARDS MO-153-AB

Figure 48. 16-Lead Thin Shrink Small Outline Package [TSSOP]  
(RU-16)

Dimensions shown in millimeters

## ORDERING GUIDE

Model	Temperature Range	Package Description	Package Option
AD5303ARU	-40°C to +105°C	16-Lead Thin Shrink Small Outline Package (TSSOP)	RU-16
AD5303ARU-REEL7	-40°C to +105°C	16-Lead Thin Shrink Small Outline Package (TSSOP)	RU-16
AD5303ARUZ <sup>1</sup>	-40°C to +105°C	16-Lead Thin Shrink Small Outline Package (TSSOP)	RU-16
AD5303BRU	-40°C to +105°C	16-Lead Thin Shrink Small Outline Package (TSSOP)	RU-16
AD5303BRU-REEL	-40°C to +105°C	16-Lead Thin Shrink Small Outline Package (TSSOP)	RU-16
AD5303BRU-REEL7	-40°C to +105°C	16-Lead Thin Shrink Small Outline Package (TSSOP)	RU-16
AD5303BRUZ <sup>1</sup>	-40°C to +105°C	16-Lead Thin Shrink Small Outline Package (TSSOP)	RU-16
AD5303BRUZ-REEL7 <sup>1</sup>	-40°C to +105°C	16-Lead Thin Shrink Small Outline Package (TSSOP)	RU-16
AD5313ARU	-40°C to +105°C	16-Lead Thin Shrink Small Outline Package (TSSOP)	RU-16
AD5313ARU-REEL7	-40°C to +105°C	16-Lead Thin Shrink Small Outline Package (TSSOP)	RU-16
AD5313ARUZ <sup>1</sup>	-40°C to +105°C	16-Lead Thin Shrink Small Outline Package (TSSOP)	RU-16
AD5313BRU	-40°C to +105°C	16-Lead Thin Shrink Small Outline Package (TSSOP)	RU-16
AD5313BRU-REEL	-40°C to +105°C	16-Lead Thin Shrink Small Outline Package (TSSOP)	RU-16
AD5313BRU-REEL7	-40°C to +105°C	16-Lead Thin Shrink Small Outline Package (TSSOP)	RU-16
AD5313BRUZ <sup>1</sup>	-40°C to +105°C	16-Lead Thin Shrink Small Outline Package (TSSOP)	RU-16
AD5323ARU	-40°C to +105°C	16-Lead Thin Shrink Small Outline Package (TSSOP)	RU-16
AD5323ARU-REEL7	-40°C to +105°C	16-Lead Thin Shrink Small Outline Package (TSSOP)	RU-16
AD5323ARUZ <sup>1</sup>	-40°C to +105°C	16-Lead Thin Shrink Small Outline Package (TSSOP)	RU-16
AD5323ARUZ-REEL7 <sup>1</sup>	-40°C to +105°C	16-Lead Thin Shrink Small Outline Package (TSSOP)	RU-16
AD5323BRU	-40°C to +105°C	16-Lead Thin Shrink Small Outline Package (TSSOP)	RU-16
AD5323BRU-REEL	-40°C to +105°C	16-Lead Thin Shrink Small Outline Package (TSSOP)	RU-16
AD5323BRU-REEL7	-40°C to +105°C	16-Lead Thin Shrink Small Outline Package (TSSOP)	RU-16
AD5323BRUZ <sup>1</sup>	-40°C to +105°C	16-Lead Thin Shrink Small Outline Package (TSSOP)	RU-16
AD5323BRUZ-REEL <sup>1</sup>	-40°C to +105°C	16-Lead Thin Shrink Small Outline Package (TSSOP)	RU-16
AD5323BRUZ-REEL7 <sup>1</sup>	-40°C to +105°C	16-Lead Thin Shrink Small Outline Package (TSSOP)	RU-16

<sup>1</sup> Z = RoHS Compliant Part.

**AD5303/AD5313/AD5323**

**NOTES**

**NOTES**

**NOTES**

## Looking for pricing, stock, or lifecycle information?

Click below to explore more details on WIN SOURCE:

 [View AD5323ARU on WIN SOURCE](#)

 [Analog Devices Inc. Information](#)

## Optimize Your Supply Chain with WIN SOURCE Solutions

-  Global Sourcing Solution
-  Obsolete Management
-  Cost Control Management
-  Shortage Management
-  Alternative Solution
-  Excess Inventory Management