



**THE DATASHEET OF
XC9572-15TQG100I**



CURRENT SENSE HIGH SIDE SWITCH

Features

- Suitable for 24V systems
- Over current shutdown
- Over temperature shutdown
- Current sensing
- Active clamp
- Low current
- Reverse battery
- ESD protection
- Optimized Turn On/Off for EMI

Applications

- 24V loads for trucks

Description

The AUIPS7111S is a fully protected four terminal high side switch. It features current sensing, over-current, over-temperature, ESD protection and drain to source active clamp. When the input voltage $V_{cc} - V_{in}$ is higher than the specified threshold, the output power Mosfet is turned on. When the $V_{cc} - V_{in}$ is lower than the specified V_{il} threshold, the output Mosfet is turned off. The I_{fb} pin is used for current sensing.

Product Summary

$R_{ds(on)}$	7.5 m Ω max.
V_{clamp}	65V
Current shutdown	30A min.

Package



D²Pak-5 leads

Typical Connection

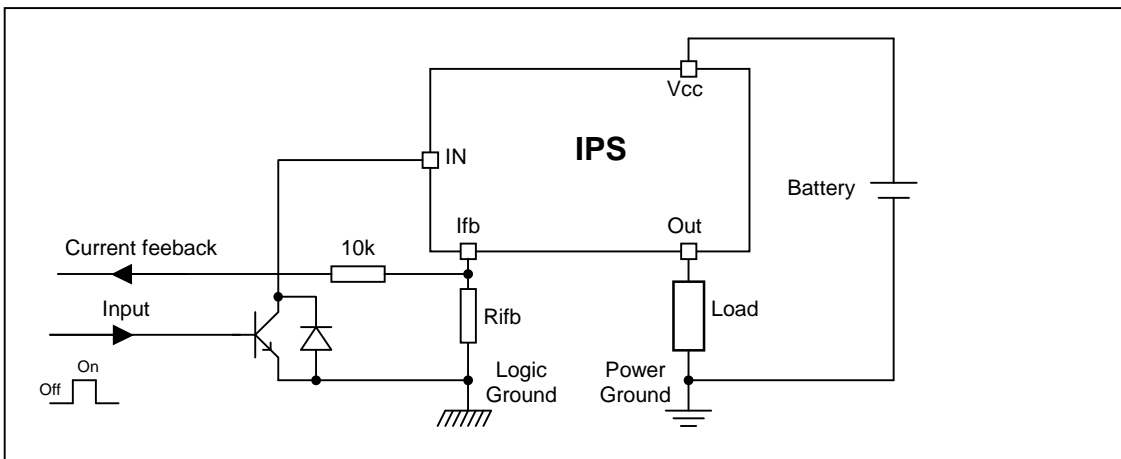

Qualification Information[†]

Qualification Level		Automotive (per AEC-Q100 ^{††})	
		Comments: This family of ICs has passed an Automotive qualification. IR's Industrial and Consumer qualification level is granted by extension of the higher Automotive level.	
Moisture Sensitivity Level		D2PAK-5L	MSL1, 260°C (per IPC/JEDEC J-STD-020)
ESD	Machine Model	Class M3 (300V) (per AEC-Q100-003)	
	Human Body Model	Class H2 (2,500 V) (per AEC-Q100-002)	
	Charged Device Model	Class C4 (1000 V) (per AEC-Q100-011)	
IC Latch-Up Test		Class II, Level A (per AEC-Q100-004)	
RoHS Compliant		Yes	

[†] Qualification standards can be found at International Rectifier's web site <http://www.irf.com/>

^{††} Exceptions to AEC-Q100 requirements are noted in the qualification report.

Absolute Maximum Ratings

Absolute maximum ratings indicate sustained limits beyond which damage to the device may occur. (T_J= -40°C..150°C, V_{CC}=8..50V unless otherwise specified).

Symbol	Parameter	Min.	Max.	Units
V _{out}	Maximum output voltage	V _{CC} -60	V _{CC} +0.3	V
V _{CC} -V _{in} max.	Maximum V _{CC} voltage	-32	60	V
I _{fb} , max.	Maximum feedback current	-50	10	mA
P _d	Maximum power dissipation (internally limited by thermal protection) T _{ambient} =25°C, T _J =150°C R _{th} =50°C/W D ² Pack 6cm ² footprint	—	2.5	W
T _J max.	Max. storage & operating junction temperature	-40	150	°C

Thermal Characteristics

Symbol	Parameter	Typ.	Max.	Units
R _{th1}	Thermal resistance junction to ambient D ² Pak Std footprint	60	—	°C/W
R _{th2}	Thermal resistance junction to ambient D ² pak 6cm ² footprint	40	—	
R _{th3}	Thermal resistance junction to case D ² pak	0.8	—	

Recommended Operating Conditions

These values are given for a quick design.

Symbol	Parameter	Min.	Max.	Units
I _{out}	Continuous output current, T _{ambient} =85°C, T _J =125°C R _{th} =40°C/W, D ² pak 6cm ² footprint	—	10	A
R _{ifb}		1.5	—	kΩ

Static Electrical Characteristics

T_j=-40..150°C, V_{cc}=8..50V (unless otherwise specified)

Symbol	Parameter	Min.	Typ.	Max.	Units	Test Conditions
V _{cc op.}	Operating voltage range	8	—	50	V	
R _{ds(on)}	ON state resistance T _j =25°C	—	6	7.5	mΩ	I _{ds} =10A
	ON state resistance T _j =150°C	—	12	15		
I _{cc off}	Supply leakage current	—	2	6	μA	V _{in} =V _{cc} =28V, V _{ifb} =V _{gnd} V _{out} =V _{gnd} , T _j =25°C
I _{out off}	Output leakage current	—	2	6		
V _{clamp1}	V _{cc} to V _{out} clamp voltage 1	60	65	—	V	Id=10mA
V _{clamp2}	V _{cc} to V _{out} clamp voltage 2	—	66	—		Id=10A see fig. 2
V _{ih(2)}	High level Input threshold voltage	—	5.5	6.8		Id=10mA
V _{il(2)}	Low level Input threshold voltage	3.5	5	—		
R _{ds(on) rev}	Reverse On state resistance T _j =25°C	—	7	10	mΩ	I _{sd} =10A, V _{cc} -V _{in} =7..32V
	Reverse On state resistance T _j =150°C	—	13	18		
V _f	Forward body diode voltage T _j =25°C	—	0.75	0.8	V	I _f =10A
	Forward body diode voltage T _j =125°C	—	0.6	0.65		
R _{in}	Internal input resistor	180	250	350	Ω	T _j =-40°C..125°C

(2) Input thresholds are measured directly between the input pin and the tab. See also page 6

Switching Electrical Characteristics

V_{cc}=28V, Resistive load=3Ω, T_j=25°C

Symbol	Parameter	Min.	Typ.	Max.	Units	Test Conditions
t _{don}	Turn on delay time to 20%	25	35	50	μs	See fig. 1
t _r	Rise time from 20% to 80% of V _{cc}	8	17	25		
t _{doff}	Turn off delay time	50	80	120	μs	
t _f	Fall time from 80% to 20% of V _{cc}	5	13	35		

Protection Characteristics

T_j=-40..150°C, V_{cc}=8..50V (unless otherwise specified)

Symbol	Parameter	Min.	Typ.	Max.	Units	Test Conditions
T _{sd}	Over temperature threshold	150(3)	165	—	°C	See fig. 3 and fig. 10
I _{sd}	Over-current shutdown	30	45	60	A	See fig. 3 and page 7
I _{fault}	I _{fb} after an over-current or an over-temperature (latched)	2.4	4	6	mA	See fig. 3

Current Sensing Characteristics

T_j=-40..150°C, V_{cc}=8..50V (unless otherwise specified)

Symbol	Parameter	Min.	Typ.	Max.	Units	Test Conditions
Ratio	I _{load} / I _{fb} current ratio	11000	13000	14500		I _{out} =10A
Ratio_TC	I _{load} / I _{fb} variation over temperature	-5%	0	+5%	%	
I _{offset}	Load current offset	-0.25	0	0.25	A	I _{out} <10A
I _{fb leakage}	I _{fb} leakage current on	0	6	15	μA	I _{out} =0A, T _j =25°C

(3) Guaranteed by design

Lead Assignments

- 1- In
- 2- Ifb
- 3- Vcc
- 4- Out
- 5- Out

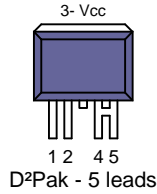

Functional Block Diagram

All values are typical

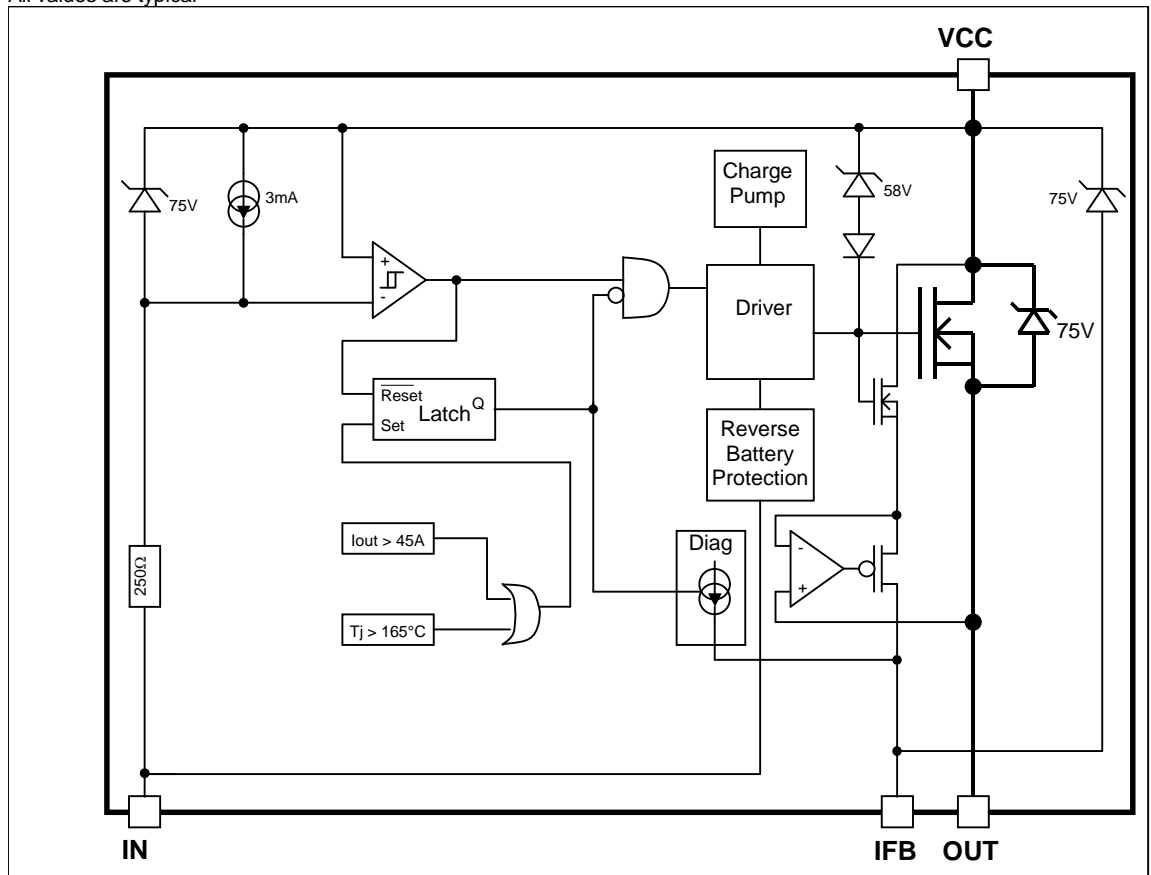

Truth Table

Op. Conditions	Input	Output	I _{fb} pin voltage
Normal mode	H	L	0V
Normal mode	L	H	I _{load} x R _{fb} / Ratio
Open load	H	L	0V
Open load	L	H	I _{fb} leakage x R _{fb}
Short circuit to GND	H	L	0V
Short circuit to GND	L	L	I _{fault} x R _{fb} (latched)
Over temperature	H	L	0V
Over temperature	L	L	I _{fault} x R _{fb} (latched)

Operating voltage

Maximum V_{cc} voltage : this is the maximum voltage before the breakdown of the IC process.

Operating voltage : This is the V_{cc} range in which the functionality of the part is guaranteed. The AEC-Q100 qualification is run at the maximum operating voltage specified in the datasheet.

Reverse battery

During the reverse battery the Mosfet is turned on if the input pin is powered with a diode in parallel of the input transistor. Power dissipation in the IPS : $P = R_{dson} \cdot I_{load}^2 + V_{cc}^2 / 250$ (internal input resistor).

If the power dissipation I too high in R_{fb}, a diode in serial can be added to block the current.

Active clamp

The purpose of the active clamp is to limit the voltage across the MOSFET to a value below the body diode break down voltage to reduce the amount of stress on the device during switching.

The temperature increase during active clamp can be estimated as follows:

$$\Delta T_j = P_{CL} \cdot Z_{TH}(t_{CLAMP})$$

Where: $Z_{TH}(t_{CLAMP})$ is the thermal impedance at t_{CLAMP} and can be read from the thermal impedance curves given in the data sheets.

$P_{CL} = V_{CL} \cdot I_{CLavg}$: Power dissipation during active clamp

$V_{CL} = 39V$: Typical V_{CLAMP} value

$I_{CLavg} = \frac{I_{CL}}{2}$: Average current during active clamp

$t_{CL} = \frac{I_{CL}}{\left| \frac{di}{dt} \right|}$: Active clamp duration

$\frac{di}{dt} = \frac{V_{Battery} - V_{CL}}{L}$: Demagnetization current

Figure 9 gives the maximum inductance versus the load current in the worst case : the part switch off after an over temperature detection. If the load inductance exceed the curve, a free wheeling diode is required.

Input level VIH/VIL

The input level are referenced to Vcc. When Vcc-Vin exceed VIH the part turns on and when Vcc-Vin goes below VIL the part turns off

Current sensing accuracy

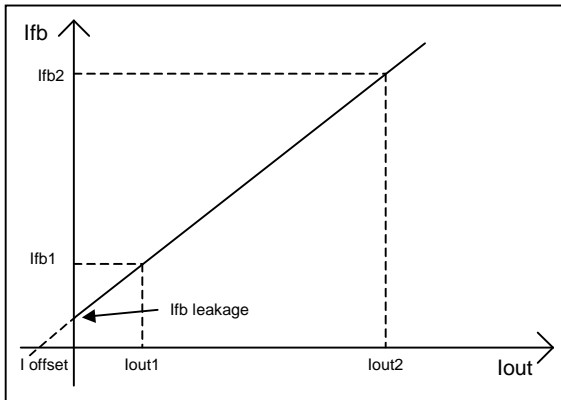

The current sensing is specified by measuring 3 points :

- I_fb1 for I_out1
- I_fb2 for I_out2
- I_fb leakage for I_out=0

The parameters in the datasheet are computed with the following formula :

$$\text{Ratio} = (I_{out2} - I_{out1}) / (I_{fb2} - I_{fb1})$$

$$I_{offset} = I_{fb1} \times \text{Ratio} - I_{out1}$$

This allows the designer to evaluate the I_fb for any I_out value using :

$$I_{fb} = (I_{out} + I_{offset}) / \text{Ratio} \text{ if } I_{fb} > I_{fb \text{ leakage}}$$

For some applications, a calibration is required. In that case, the accuracy of the system will depends on the variation of the I_offset and the ratio over the temperature range. The ratio variation is given by Ratio_TC specified in page 4.

The I_offset variation depends directly of the R_dson :

$$I_{offset@-40^{\circ}\text{C}} = I_{offset@25^{\circ}\text{C}} / 0.7$$

$$I_{offset@150^{\circ}\text{C}} = I_{offset@25^{\circ}\text{C}} / 1.9$$

Over-current protection

The threshold of the over-current protection is set in order to guaranteed that the device is able to turn on a load with an inrush current lower than the minimum of I_sd. Nevertheless for high current and high temperature the device may switch off for a lower current due to the over-temperature protection (see Figure 10).

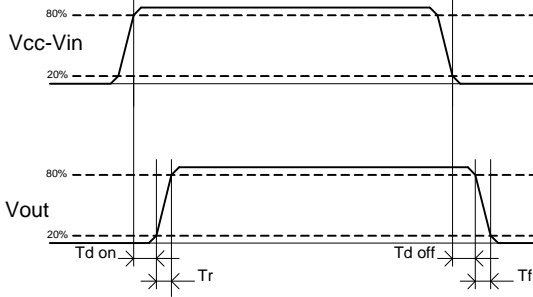
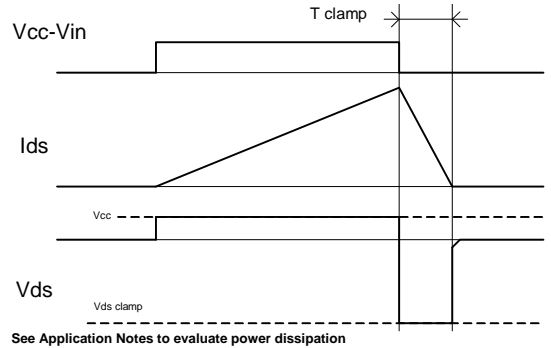

Figure 1 – IN rise time & switching definitions



See Application NOTES to evaluate power dissipation

Figure 2 – Active clamp waveforms

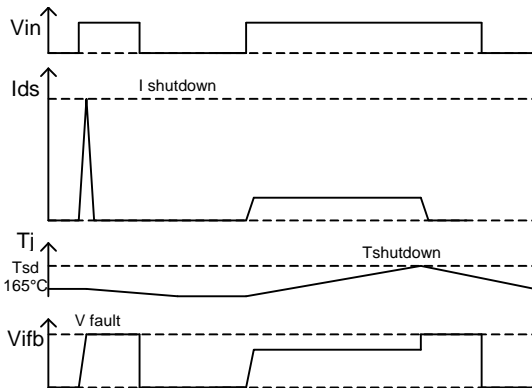

Figure 3 – Protection timing diagram

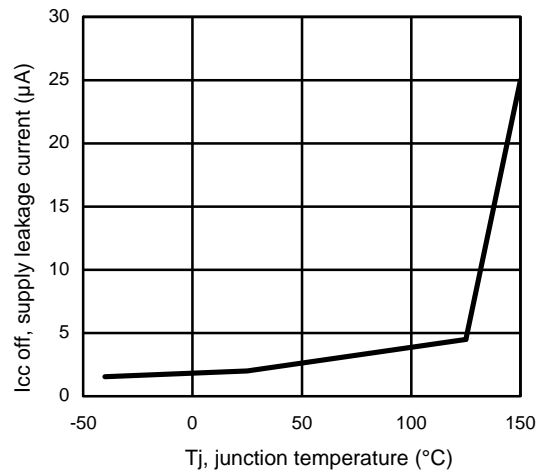

Figure 4 – Icc off (µA) Vs Tj (°C)

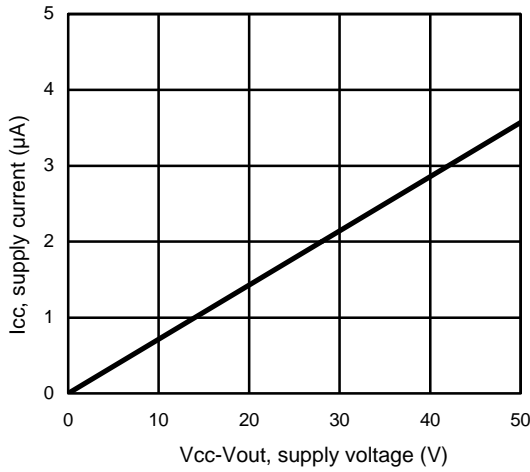

Figure 5 – Icc Off(µA) Vs Vcc-Vout (V)

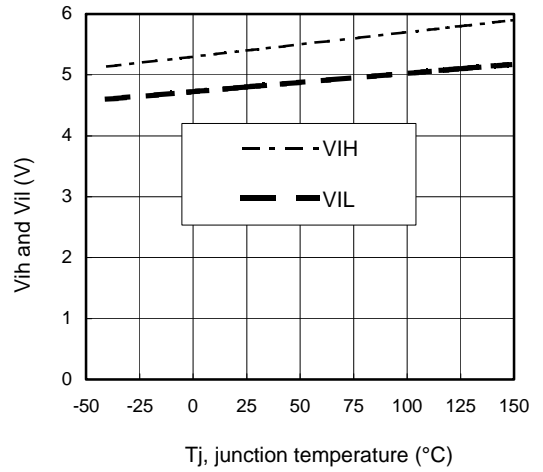

Figure 6 – Vih and Vil (V) Vs Tj (°C)

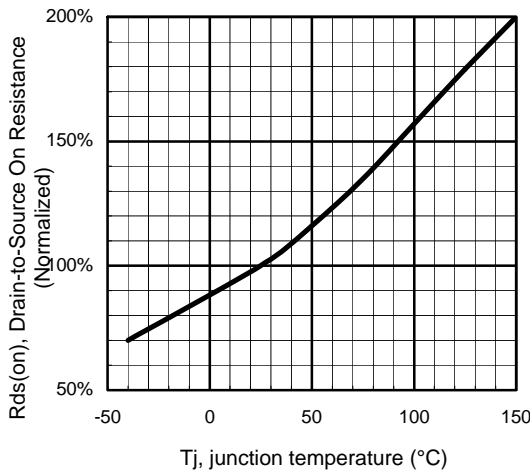

Figure 7 - Normalized Rds(on) (%) Vs Tj (°C)

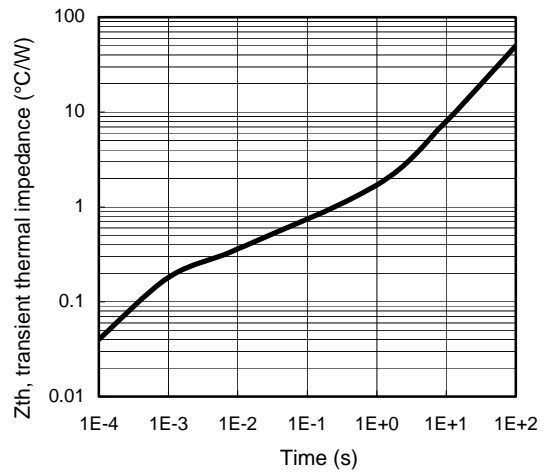

Figure 8 – Transient thermal impedance (°C/W) Vs time (s)

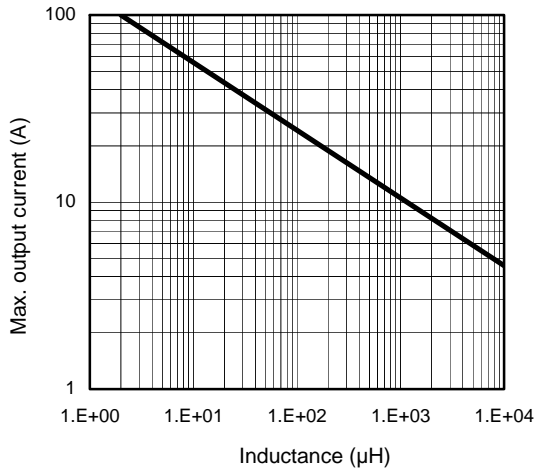
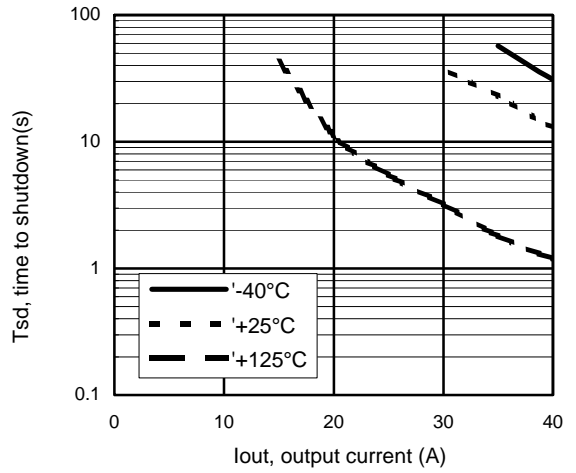
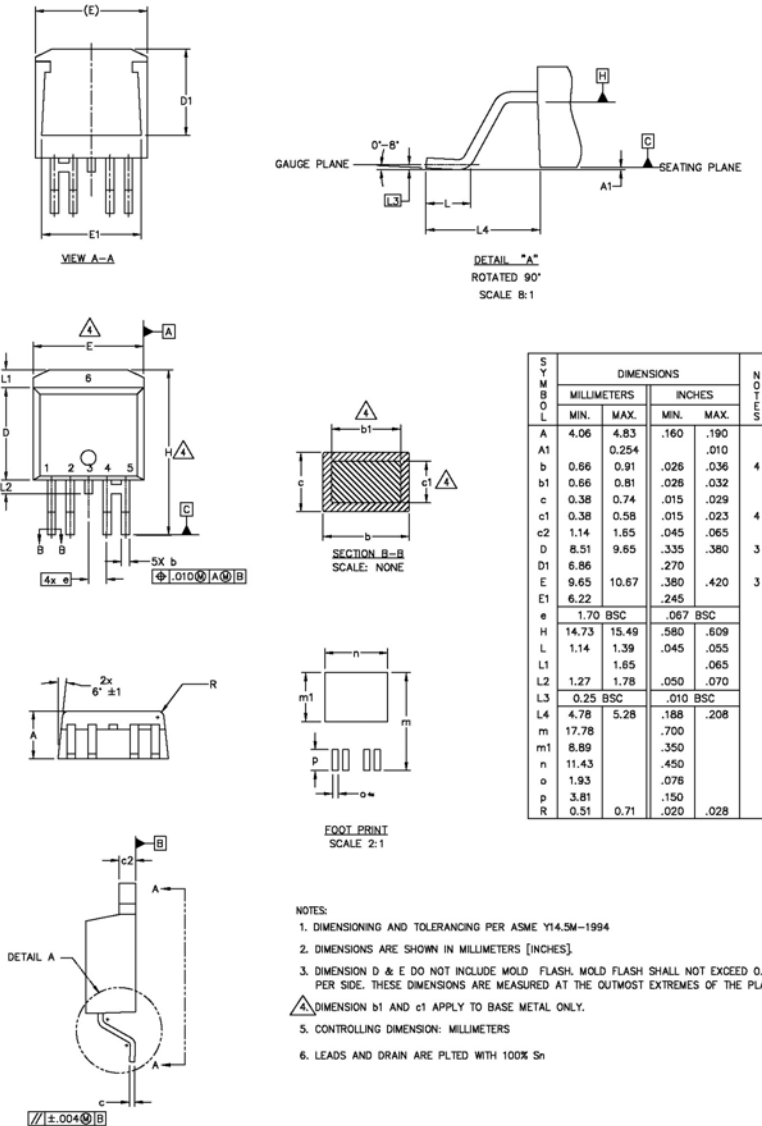

Figure 9 – Max. I_{out} (A) Vs inductance (μH)

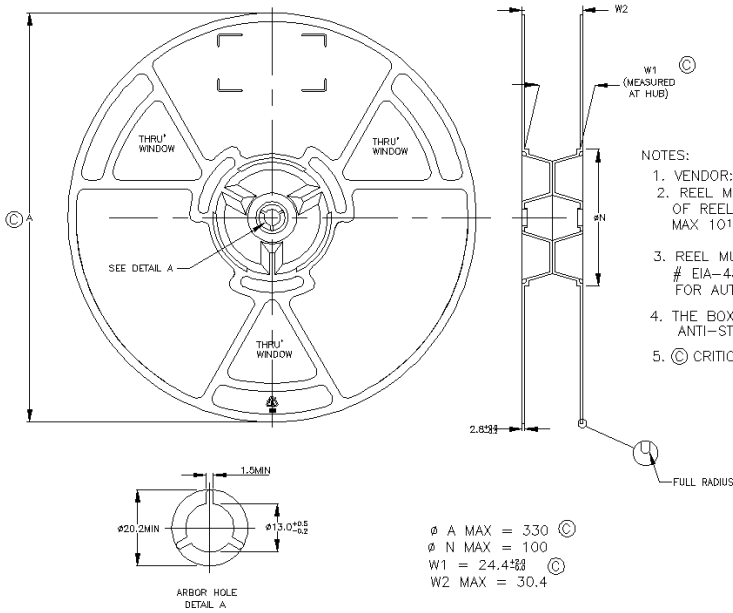

**Figure 10 – Tsd (s) Vs I_{out} (A)
 SMD with 6cm²**

Case Outline D2PAK - 5 Leads



Tape & Reel D2PAK - 5 Leads



Part Marking Information

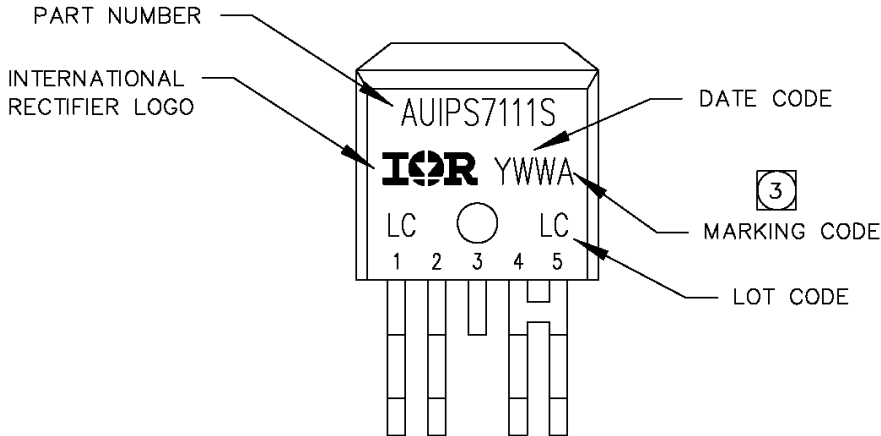

Ordering Information

Base Part Number	Package Type	Standard Pack		Complete Part Number
		Form	Quantity	
AUIPS7111R	D2-Pak-5-Leads	Tube	50	AUIPS7111S
		Tape and reel left	800	AUIPS7111STRL
		Tape and reel right	800	AUIPS7111STRR

IMPORTANT NOTICE

Unless specifically designated for the automotive market, International Rectifier Corporation and its subsidiaries (IR) reserve the right to make corrections, modifications, enhancements, improvements, and other changes to its products and services at any time and to discontinue any product or services without notice. Part numbers designated with the "AU" prefix follow automotive industry and / or customer specific requirements with regards to product discontinuance and process change notification. All products are sold subject to IR's terms and conditions of sale supplied at the time of order acknowledgment.

IR warrants performance of its hardware products to the specifications applicable at the time of sale in accordance with IR's standard warranty. Testing and other quality control techniques are used to the extent IR deems necessary to support this warranty. Except where mandated by government requirements, testing of all parameters of each product is not necessarily performed.

IR assumes no liability for applications assistance or customer product design. Customers are responsible for their products and applications using IR components. To minimize the risks with customer products and applications, customers should provide adequate design and operating safeguards.

Reproduction of IR information in IR data books or data sheets is permissible only if reproduction is without alteration and is accompanied by all associated warranties, conditions, limitations, and notices. Reproduction of this information with alterations is an unfair and deceptive business practice. IR is not responsible or liable for such altered documentation. Information of third parties may be subject to additional restrictions.

Resale of IR products or serviced with statements different from or beyond the parameters stated by IR for that product or service voids all express and any implied warranties for the associated IR product or service and is an unfair and deceptive business practice. IR is not responsible or liable for any such statements.

IR products are not designed, intended, or authorized for use as components in systems intended for surgical implant into the body, or in other applications intended to support or sustain life, or in any other application in which the failure of the IR product could create a situation where personal injury or death may occur. Should Buyer purchase or use IR products for any such unintended or unauthorized application, Buyer shall indemnify and hold International Rectifier and its officers, employees, subsidiaries, affiliates, and distributors harmless against all claims, costs, damages, and expenses, and reasonable attorney fees arising out of, directly or indirectly, any claim of personal injury or death associated with such unintended or unauthorized use, even if such claim alleges that IR was negligent regarding the design or manufacture of the product.

IR products are neither designed nor intended for use in military/aerospace applications or environments unless the IR products are specifically designated by IR as military-grade or

“enhanced plastic.” Only products designated by IR as military-grade meet military specifications. Buyers acknowledge and agree that any such use of IR products which IR has not designated as military-grade is solely at the Buyer’s risk, and that they are solely responsible for compliance with all legal and regulatory requirements in connection with such use.

IR products are neither designed nor intended for use in automotive applications or environments unless the specific IR products are designated by IR as compliant with ISO/TS 16949 requirements and bear a part number including the designation “AU”. Buyers acknowledge and agree that, if they use any non-designated products in automotive applications, IR will not be responsible for any failure to meet such requirements.

For technical support, please contact IR’s Technical Assistance Center
<http://www.irf.com/technical-info/>

WORLD HEADQUARTERS:

233 Kansas St., El Segundo, California 90245
Tel: (310) 252-7105







Looking for pricing, stock, or lifecycle information?

Click below to explore more details on WIN SOURCE:

 [View XC9572-15TQG100I on WIN SOURCE](#)

 [Xilinx Inc. Information](#)

Optimize Your Supply Chain with WIN SOURCE Solutions

-  Global Sourcing Solution
-  Obsolete Management
-  Cost Control Management
-  Shortage Management
-  Alternative Solution
-  Excess Inventory Management