



THE DATASHEET OF NCS2553DG



NCS2553

3-Channel Video Amp with Standard Definition Reconstruction Filters

Description

The NCS2553 is a 3-channel high speed video amplifier with 6th order butterworth standard definition reconstruction filter.

All three channels can accommodate either all component and RGB video signals or composite and S-Video signals. All channels can accept DC or AC coupled signals. If AC coupled, the internal clamps are employed. The outputs can drive both AC and DC coupled 150 Ω loads.

It is designed to be compatible with most digital-to-analog converters (DAC) embedded in most video processors.

Feature

- Three 6th Order Standard Definition 8 MHz Filters
- Internally Fixed Gain = 6 dB
- AC- or DC- Coupled Inputs
- AC- or DC- Coupled Outputs
- Integrated Level Shifter
- Operating Voltage +5 V
- Available in a SOIC-8 Package
- These are Pb-Free Devices

Applications

- Digital Set-Top Box
- DVD / Video Players and Related
- SD-TV
- Video On Demand (VOD)
- Video Recorders



ON Semiconductor®

<http://onsemi.com>



SOIC-8 NB
D SUFFIX
CASE 751

MARKING DIAGRAM

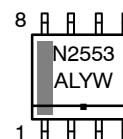

- A = Assembly Location
- L = Wafer Lot
- Y = Year
- W = Work Week
- = Pb-Free Package

PINOUT

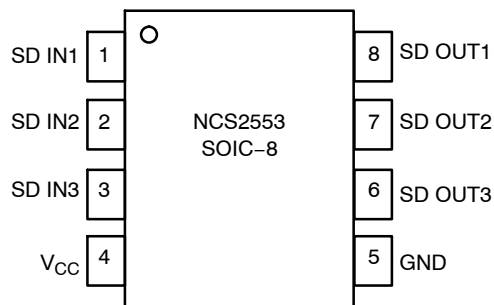

ORDERING INFORMATION

Device	Package	Shipping†
NCS2553DG	SOIC-8 (Pb-Free)	98 Units / Rail
NCS2553DR2G	SOIC-8 (Pb-Free)	2500 / Tape & Reel

†For information on tape and reel specifications, including part orientation and tape sizes, please refer to our Tape and Reel Packaging Specifications Brochure, BRD8011/D.

NCS2553

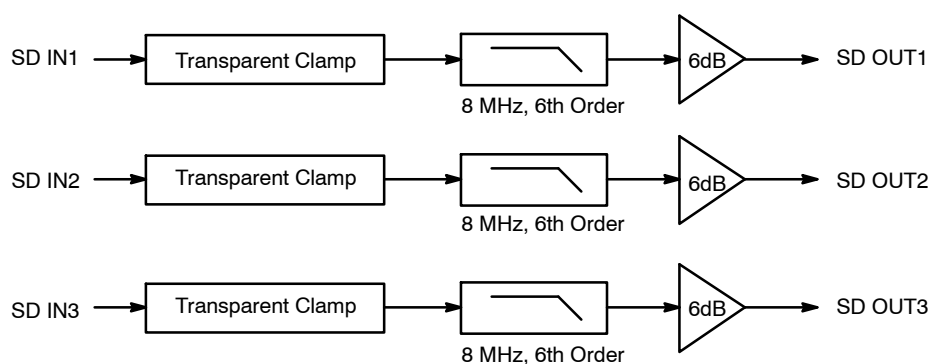

Figure 1. Block Diagram

PIN FUNCTION AND DESCRIPTION

Pin	Name	Type	Description
1	IN1	Input	Video Input 1 for Video Signal featuring a frequency bandwidth compatible with Standard Definition Video (8 MHz) – Channel 1
2	IN2	Input	Video Input 2 for Video Signal featuring a frequency bandwidth compatible with Standard Definition Video (8 MHz) – Channel 2
3	IN3	Input	Video Input 3 for Video Signal featuring a frequency bandwidth compatible with Standard Definition Video (8 MHz) – Channel 3
4	VCC	Power	Device Power Supply Voltage: +5 V
5	GND	GND	Connected to Ground
6	OUT3	Output	SD Video Output 3 – Channel 3
7	OUT2	Output	SD Video Output 2 – Channel 2
8	OUT1	Output	SD Video Output 1 – Channel 1

ATTRIBUTES

Characteristics	Value
ESD	
Human Body Model	All Pins (Note 1) 8 kV
Machine Model	Pins 1 to 5 (Note 2) 800 V
	All Output Pins (Note 2) 400 V
Moisture Sensitivity (Note 3)	Level 1
Flammability Rating – Oxygen Index: 28 to 34	UL 94 V-0 @ 0.125 in

1. Human Body Model (HBM): R = 1500 Ω , C = 100 pF
2. Machine Model (MM)
3. For additional information, see Application Note AND8003/D.

MAXIMUM RATINGS

Parameter	Symbol	Rating	Unit
Power Supply Voltages	V_{CC}	$-0.35 \leq V_{CC} \leq 5.5$	Vdc
Input Voltage Range	V_I	$-0.3 \leq V_I \leq V_{CC}$	Vdc
Input Differential Voltage Range	V_{ID}	$V_I \leq V_{CC}$	Vdc
Output Current	I_O	50	mA
Maximum Junction Temperature (Note 4)	T_J	150	°C
Operating Ambient Temperature	T_A	-40 to +85	°C
Storage Temperature Range	T_{stg}	-60 to +150	°C
Power Dissipation	P_D	(See Graph)	mW
Thermal Resistance, Junction-to-Air	$R_{\theta JA}$	112.7	°C/W

Stresses exceeding Maximum Ratings may damage the device. Maximum Ratings are stress ratings only. Functional operation above the Recommended Operating Conditions is not implied. Extended exposure to stresses above the Recommended Operating Conditions may affect device reliability.

4. Power dissipation must be considered to ensure maximum junction temperature (T_J) is not exceeded.

Maximum Power Dissipation

The maximum power that can be safely dissipated is limited by the associated rise in junction temperature.

For the plastic packages, the maximum safe junction temperature is 150°C. If the maximum is exceeded momentarily, proper circuit operation will be restored as soon as the die temperature is reduced. Leaving the device in the “overheated” condition for an extended period can result in device burnout. To ensure proper operation, it is important to observe the de-rating curves.

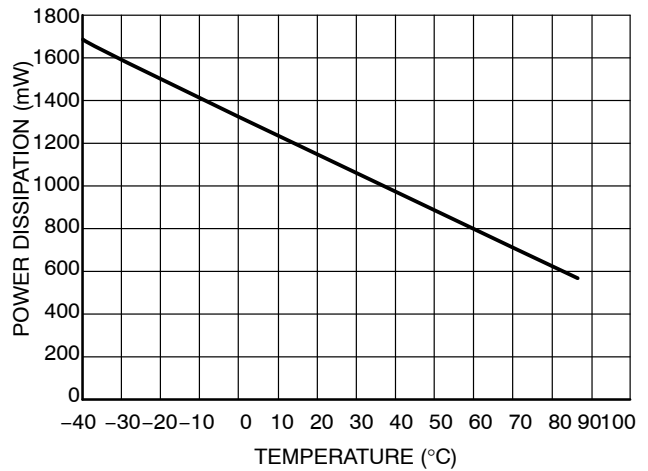

Figure 2. Power Dissipation vs Temperature

NCS2553

DC ELECTRICAL CHARACTERISTICS ($V_{CC} = +5.0\text{ V}$, $T_A = 25^\circ\text{C}$, $0.1\ \mu\text{F}$ AC coupled inputs, $R_{\text{source}} = 37.5\ \Omega$, $220\ \mu\text{F}$ AC coupled outputs into $150\ \Omega$ load, referenced to 400 kHz, unless otherwise specified)

Symbol	Characteristics	Conditions	Min	Typ	Max	Unit
V_{CC}	Supply Voltage Range		4.75	5.0	5.25	V
I_{CC}	Power Supply Current	No Load		23	30	mA
V_{IN}	Input Common Mode Voltage Range	Referenced to GND if DC-Coupled	GND		1.4	
PSRR	Power Supply Rejection	DC (All Channels)		-50		dB

NOTE: Device will meet the specifications after thermal equilibrium has been established when mounted in a test socket or printed circuit board with maintained transverse airflow greater than 500 lpm. Electrical parameters are guaranteed only over the declared operating temperature range. Functional operation of the device exceeding these conditions is not implied. Device specification limit values are applied individually under normal operating conditions and not valid simultaneously.

AC ELECTRICAL CHARACTERISTICS ($V_{CC} = +5.0\text{ V}$, $T_A = 25^\circ\text{C}$, $0.1\ \mu\text{F}$ AC coupled inputs, $R_{\text{source}} = 37.5\ \Omega$, $220\ \mu\text{F}$ AC coupled outputs into $150\ \Omega$ load, referenced to 400 kHz, unless otherwise specified)

Symbol	Characteristics	Conditions	Min	Typ	Max	Unit
A_{VOL}	Voltage Gain (Note 5)	$V_{IN} = 1\text{ V}$ (All Channels)	5.8	6.0	6.2	dB
BW	Low Pass Filter Bandwidth	-1 dB (Note 6)	5.5	7.2		MHz
		-3 dB		9.0		MHz
A_R	Stop-Band Attenuation (Rejection)	at 27 MHz		45		dB
dG	Differential Gain			0.3		%
d θ	Differential Phase			0.6		°
THD	Total Harmonic Distortion	$V_{OUT} = 1.8\text{ V}_{PP}$ @ 1 MHz		0.4		%
X_{talk}	Channel-to-Channel Crosstalk	$V_{OUT} = 1.8\text{ V}_{PP}$ @ 1 MHz		-60		dB
SNR	Signal-to-Noise Ratio	NTSC-7, 100 kHz to 4.2 MHz (Note 7)		75		dB
Tpd	Propagation Delay	Input-to-Output, 4.5 MHz		60		nsec
ΔGD	Group Delay Variation from 100 kHz to 8 MHz			27		ns

NOTE: Device will meet the specifications after thermal equilibrium has been established when mounted in a test socket or printed circuit board with maintained transverse airflow greater than 500 lpm. Electrical parameters are guaranteed only over the declared operating temperature range. Functional operation of the device exceeding these conditions is not implied. Device specification limit values are applied individually under normal operating conditions and not valid simultaneously.

5. 100% of tested IC fit to the bandwidth tolerance.
6. Guaranteed by design and characterization.
7. $\text{SNR} = 20 \times \log(714\text{ mV/RMS Noise})$

TYPICAL CHARACTERISTICS

$V_{CC} = +5.0\text{ V}$, $R_{source} = 37.5\ \Omega$, $T_A = 25^\circ\text{C}$, $0.1\ \mu\text{F}$ AC-coupled inputs, $220\ \mu\text{F}$ AC-coupled outputs into $150\ \Omega$ referenced to $400\ \text{kHz}$, all channels, unless otherwise specified

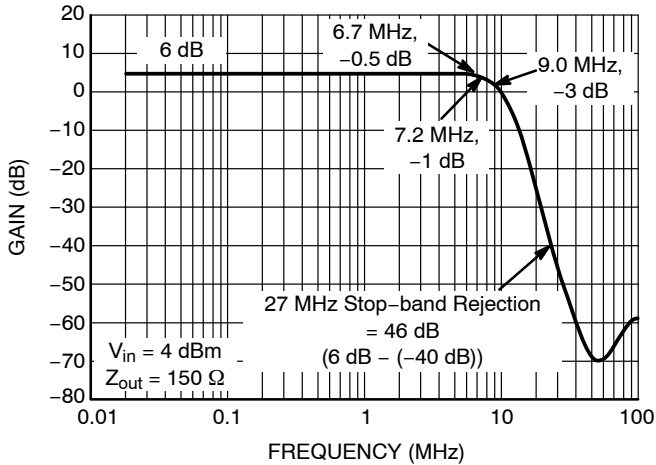

Figure 3. Frequency Response

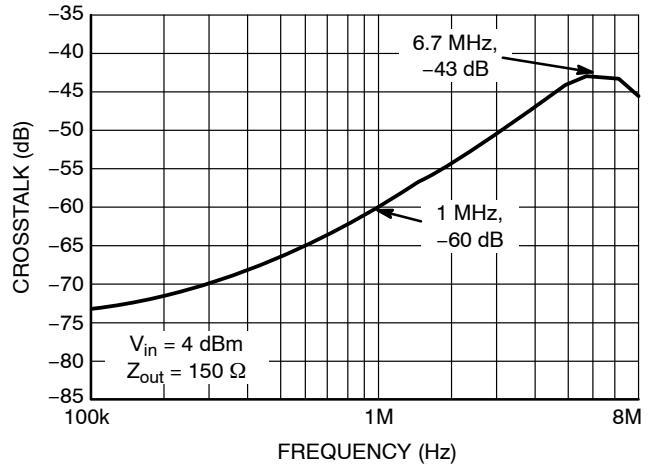

Figure 4. Channel-to-Channel Crosstalk

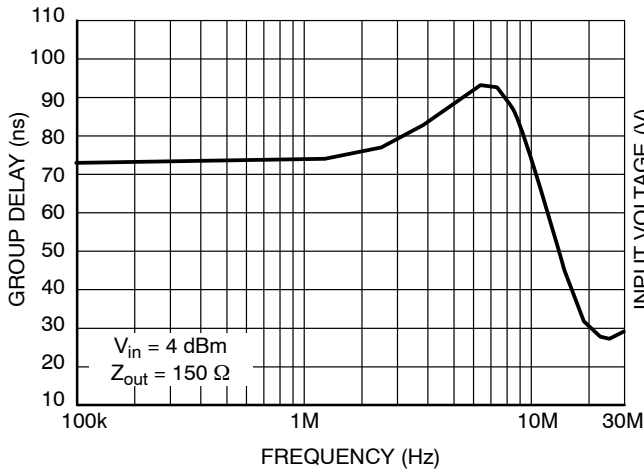

Figure 5. Group Delay

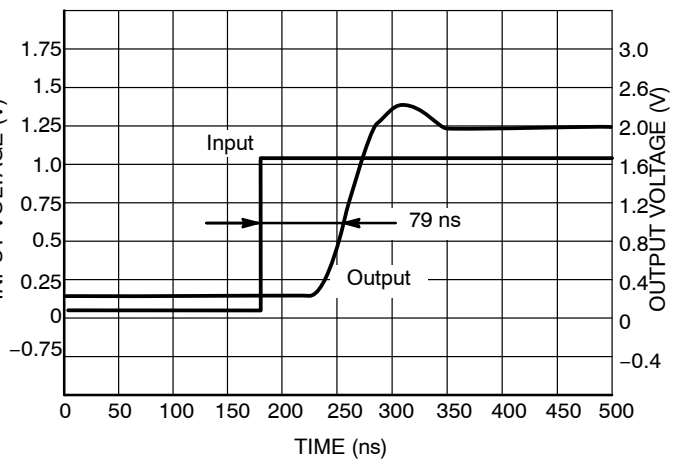

Figure 6. Propagation Delay

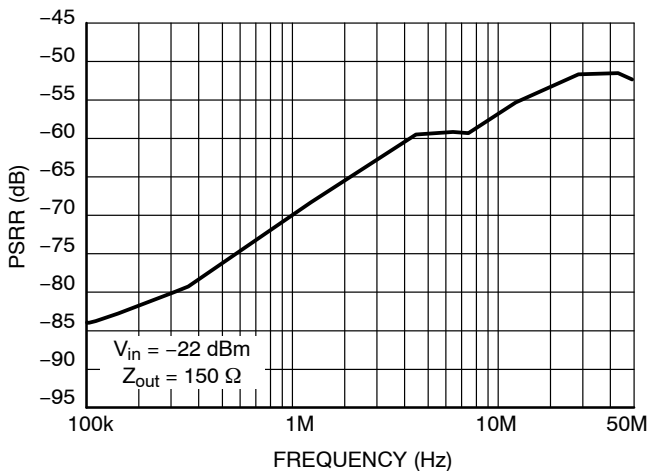

Figure 7. PSRR vs Frequency (No Bypass Capacitor)

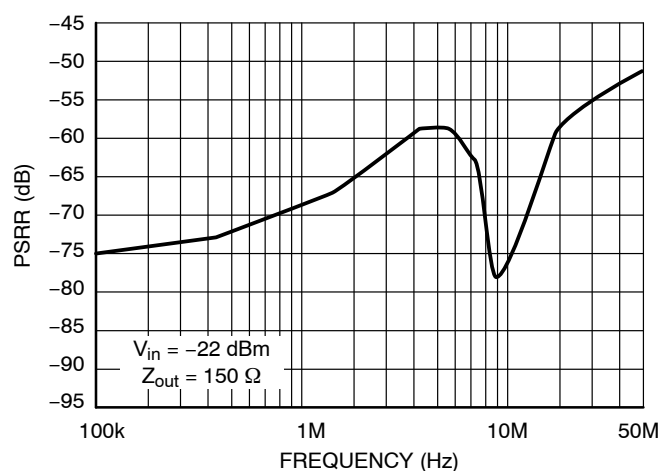

Figure 8. PSRR vs. Frequency (Bypass Capacitor)

TYPICAL CHARACTERISTICS

$V_{CC} = +5.0\text{ V}$, $R_{source} = 37.5\ \Omega$, $T_A = 25^\circ\text{C}$, $0.1\ \mu\text{F}$ AC-coupled inputs, $220\ \mu\text{F}$ AC-coupled outputs into $150\ \Omega$ referenced to $400\ \text{kHz}$, all channels, unless otherwise specified

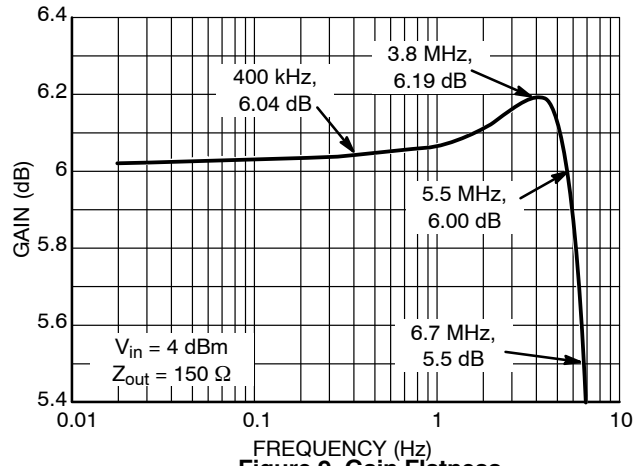

Figure 9. Gain Flatness

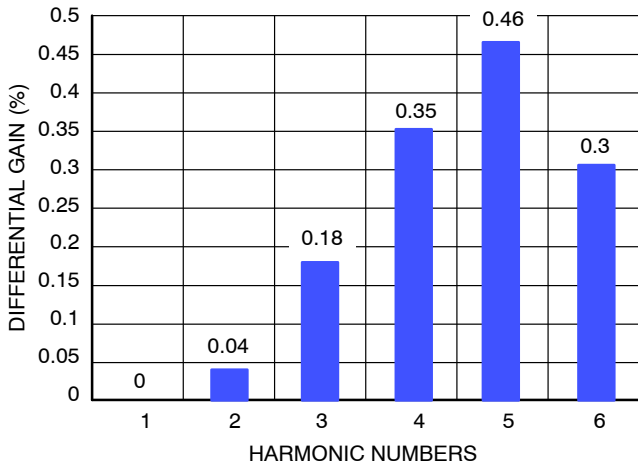

Figure 10. Differential Gain (NTSC 5 Steps Input Signal)

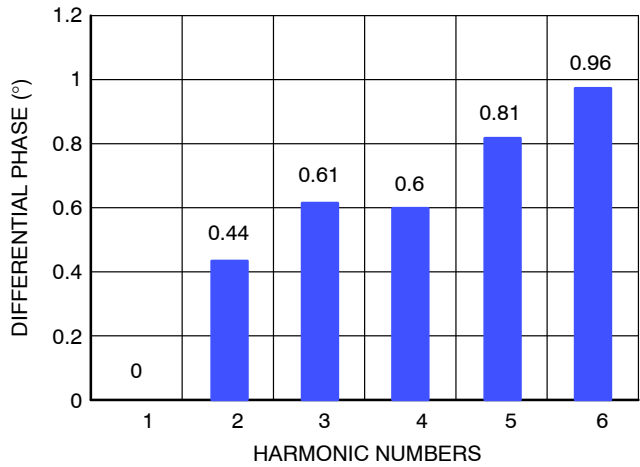

Figure 11. Differential Phase (NTSC 5 Steps Input Signal)

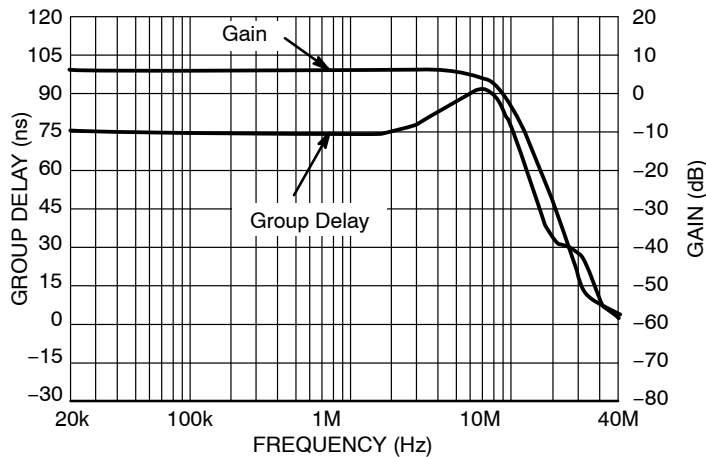

Figure 12. Normalized Frequency Response and Group Delay vs. Frequency

APPLICATIONS INFORMATION

The NCS2553 triple video driver has been optimized for Standard Definition video applications covering the requirements of the CVBS, S-Video, 480i/525i & 576i/625i standards. All the 3 channels feature the same specifications and similar behaviors guaranteed by a high channel-to-channel crosstalk isolation (down to 60 dB at 1 MHz). Each channel provides an internal voltage-to-voltage gain of 2 from its input to its output reducing the number of external components usually needed in the case of some discrete approaches (using stand-alone op amps). An internal level shifter is employed shifting up the output voltage by adding an offset of about 280 mV. This avoids sync pulse clipping

and allows DC-coupled output to the 150 Ω video load. In addition, the NCS2553 integrates a 6th order Butterworth filter per channel with a 3 dB frequency bandwidth of 8 MHz. This allows rejecting out the aliases or unwanted over-sampling effects produced by the video DAC. Similarly, in the case of DVD recorders using ADC, this anti-aliasing filter (reconstruction filter) will avoid picture quality issues and will help to filter out parasitic signals caused by EMI interference.

A built-in diode-like clamp is used in the chip for each channel to support AC-coupled mode of operation. The clamp is active when the input signal goes below 0 V.

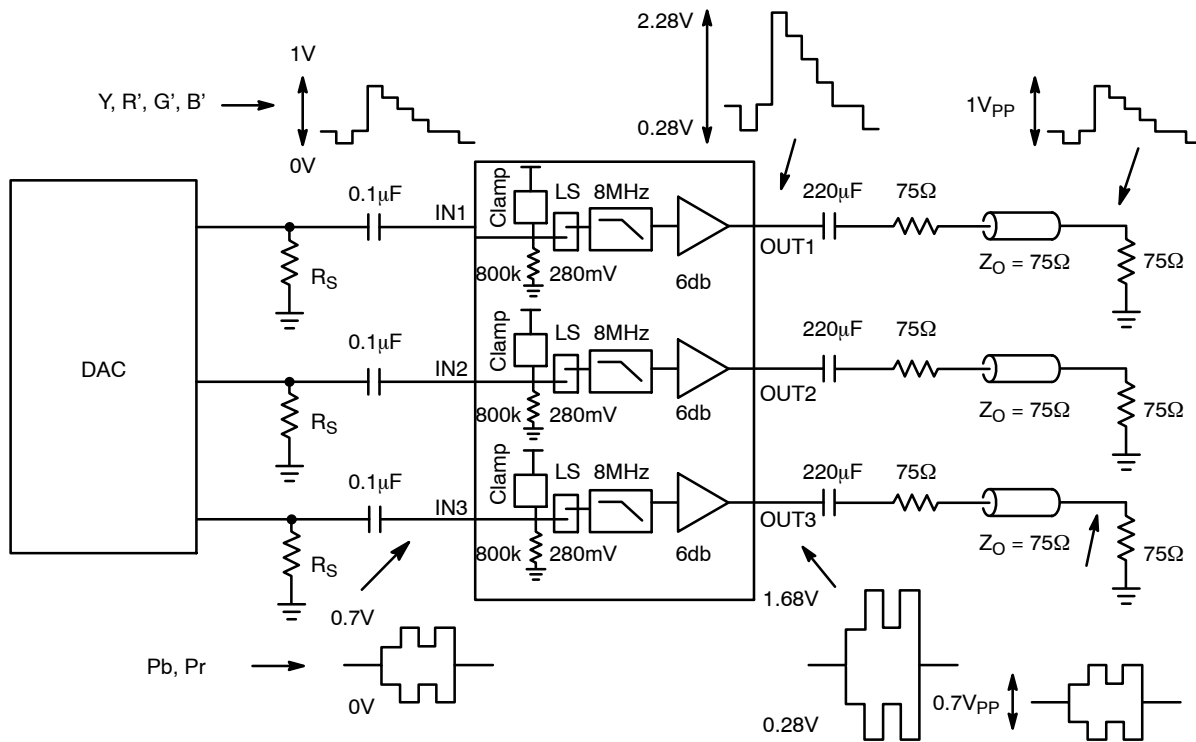

Figure 13. AC-Coupled Inputs and Outputs

Figure 13 shows an example for which the external video source coming from the DAC is AC-coupled at the input and output. But thanks to the built-in transparent clamp and level shifter the device can operate in different configuration modes depending essentially on the DAC output signal level High and Low and how it fits the input common mode voltage of the video driver. When the configuration is DC-Coupled at the Inputs and Outputs the 0.1 μF and 220 μF coupling capacitors are no longer used, the clamps are in that case inactive; this configuration has the big advantage of being relatively low cost with the use of less external components.

The input is AC-coupled if for example the input-signal amplitude goes over the range 0 to 1.4 V or if the video source requires such a coupling. In some circumstances it may be necessary to auto-bias signals by the addition of a pull-up and pull-down resistor or only pull-up resistor (Typical 7.5 MΩ combined with the internal 800 kΩ pull-down) making the clamp inactive.

The output AC-coupling configuration has the advantage of eliminating DC ground loop with the drawback of making the device more sensitive to video line or field tilt issues in the case of a too low output coupling capacitor. In some cases it may be necessary to increase the nominal 220 μF capacitor value.

NCS2553

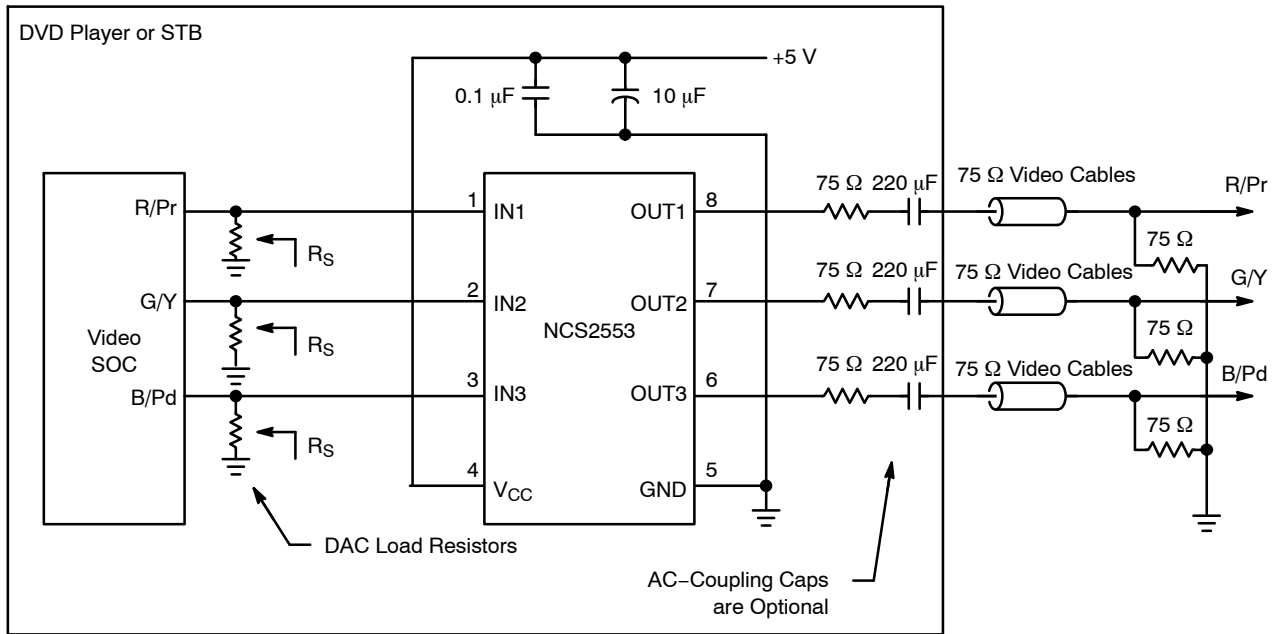
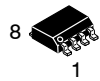

Figure 14. Typical Application Circuit

MECHANICAL CASE OUTLINE PACKAGE DIMENSIONS



SCALE 1:1

SOIC-8 NB
CASE 751-07
ISSUE AK

DATE 16 FEB 2011

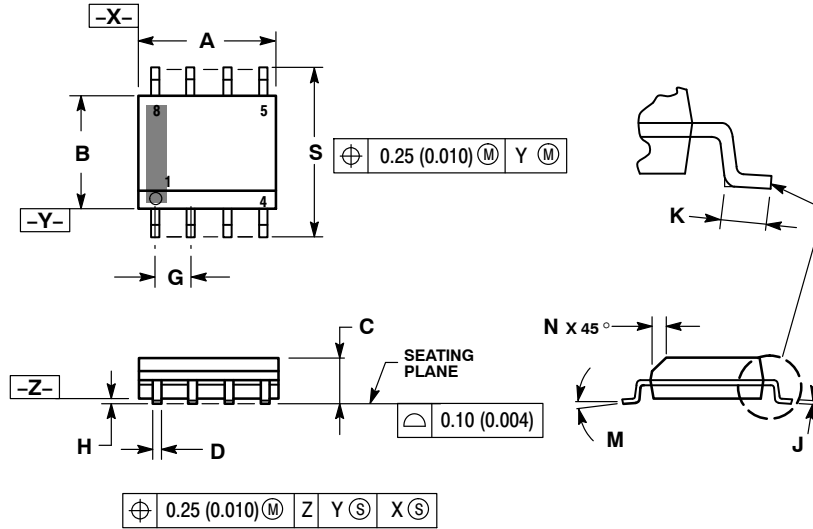

- NOTES:
1. DIMENSIONING AND TOLERANCING PER ANSI Y14.5M, 1982.
 2. CONTROLLING DIMENSION: MILLIMETER.
 3. DIMENSION A AND B DO NOT INCLUDE MOLD PROTRUSION.
 4. MAXIMUM MOLD PROTRUSION 0.15 (0.006) PER SIDE.
 5. DIMENSION D DOES NOT INCLUDE DAMBAR PROTRUSION. ALLOWABLE DAMBAR PROTRUSION SHALL BE 0.127 (0.005) TOTAL IN EXCESS OF THE D DIMENSION AT MAXIMUM MATERIAL CONDITION.
 6. 751-01 THRU 751-06 ARE OBSOLETE. NEW STANDARD IS 751-07.

DIM	MILLIMETERS		INCHES	
	MIN	MAX	MIN	MAX
A	4.80	5.00	0.189	0.197
B	3.80	4.00	0.150	0.157
C	1.35	1.75	0.053	0.069
D	0.33	0.51	0.013	0.020
G	1.27 BSC		0.050 BSC	
H	0.10	0.25	0.004	0.010
J	0.19	0.25	0.007	0.010
K	0.40	1.27	0.016	0.050
M	0°	8°	0°	8°
N	0.25	0.50	0.010	0.020
S	5.80	6.20	0.228	0.244

GENERIC MARKING DIAGRAM*

SOLDERING FOOTPRINT*

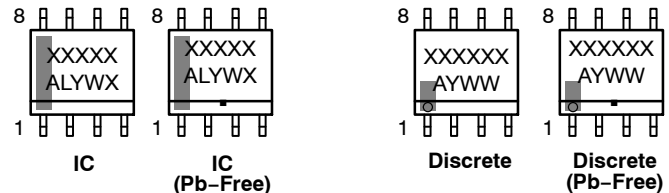
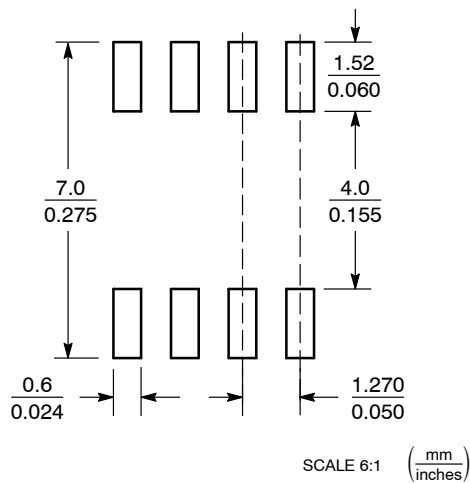

XXXXXX = Specific Device Code
A = Assembly Location
L = Wafer Lot
Y = Year
W = Work Week
▪ = Pb-Free Package

XXXXXX = Specific Device Code
A = Assembly Location
Y = Year
WW = Work Week
▪ = Pb-Free Package

*This information is generic. Please refer to device data sheet for actual part marking. Pb-Free indicator, "G" or microdot "▪", may or may not be present. Some products may not follow the Generic Marking.

*For additional information on our Pb-Free strategy and soldering details, please download the ON Semiconductor Soldering and Mounting Techniques Reference Manual, SOLDERRM/D.

STYLES ON PAGE 2

DOCUMENT NUMBER:	98ASB42564B	Electronic versions are uncontrolled except when accessed directly from the Document Repository. Printed versions are uncontrolled except when stamped "CONTROLLED COPY" in red.
DESCRIPTION:	SOIC-8 NB	PAGE 1 OF 2

onsemi and ONsemi are trademarks of Semiconductor Components Industries, LLC dba onsemi or its subsidiaries in the United States and/or other countries. onsemi reserves the right to make changes without further notice to any products herein. onsemi makes no warranty, representation or guarantee regarding the suitability of its products for any particular purpose, nor does onsemi assume any liability arising out of the application or use of any product or circuit, and specifically disclaims any and all liability, including without limitation special, consequential or incidental damages. onsemi does not convey any license under its patent rights nor the rights of others.

SOIC-8 NB
CASE 751-07
ISSUE AK

DATE 16 FEB 2011

- | | | | |
|--|---|---|---|
| <p>STYLE 1:
 PIN 1. EMITTER
 2. COLLECTOR
 3. COLLECTOR
 4. EMITTER
 5. EMITTER
 6. BASE
 7. BASE
 8. EMITTER</p> | <p>STYLE 2:
 PIN 1. COLLECTOR, DIE, #1
 2. COLLECTOR, #1
 3. COLLECTOR, #2
 4. COLLECTOR, #2
 5. BASE, #2
 6. EMITTER, #2
 7. BASE, #1
 8. EMITTER, #1</p> | <p>STYLE 3:
 PIN 1. DRAIN, DIE #1
 2. DRAIN, #1
 3. DRAIN, #2
 4. DRAIN, #2
 5. GATE, #2
 6. SOURCE, #2
 7. GATE, #1
 8. SOURCE, #1</p> | <p>STYLE 4:
 PIN 1. ANODE
 2. ANODE
 3. ANODE
 4. ANODE
 5. ANODE
 6. ANODE
 7. ANODE
 8. COMMON CATHODE</p> |
| <p>STYLE 5:
 PIN 1. DRAIN
 2. DRAIN
 3. DRAIN
 4. DRAIN
 5. GATE
 6. GATE
 7. SOURCE
 8. SOURCE</p> | <p>STYLE 6:
 PIN 1. SOURCE
 2. DRAIN
 3. DRAIN
 4. SOURCE
 5. SOURCE
 6. GATE
 7. GATE
 8. SOURCE</p> | <p>STYLE 7:
 PIN 1. INPUT
 2. EXTERNAL BYPASS
 3. THIRD STAGE SOURCE
 4. GROUND
 5. DRAIN
 6. GATE 3
 7. SECOND STAGE Vd
 8. FIRST STAGE Vd</p> | <p>STYLE 8:
 PIN 1. COLLECTOR, DIE #1
 2. BASE, #1
 3. BASE, #2
 4. COLLECTOR, #2
 5. COLLECTOR, #2
 6. EMITTER, #2
 7. EMITTER, #1
 8. COLLECTOR, #1</p> |
| <p>STYLE 9:
 PIN 1. EMITTER, COMMON
 2. COLLECTOR, DIE #1
 3. COLLECTOR, DIE #2
 4. EMITTER, COMMON
 5. EMITTER, COMMON
 6. BASE, DIE #2
 7. BASE, DIE #1
 8. EMITTER, COMMON</p> | <p>STYLE 10:
 PIN 1. GROUND
 2. BIAS 1
 3. OUTPUT
 4. GROUND
 5. GROUND
 6. BIAS 2
 7. INPUT
 8. GROUND</p> | <p>STYLE 11:
 PIN 1. SOURCE 1
 2. GATE 1
 3. SOURCE 2
 4. GATE 2
 5. DRAIN 2
 6. DRAIN 2
 7. DRAIN 1
 8. DRAIN 1</p> | <p>STYLE 12:
 PIN 1. SOURCE
 2. SOURCE
 3. SOURCE
 4. GATE
 5. DRAIN
 6. DRAIN
 7. DRAIN
 8. DRAIN</p> |
| <p>STYLE 13:
 PIN 1. N.C.
 2. SOURCE
 3. SOURCE
 4. GATE
 5. DRAIN
 6. DRAIN
 7. DRAIN
 8. DRAIN</p> | <p>STYLE 14:
 PIN 1. N-SOURCE
 2. N-GATE
 3. P-SOURCE
 4. P-GATE
 5. P-DRAIN
 6. P-DRAIN
 7. N-DRAIN
 8. N-DRAIN</p> | <p>STYLE 15:
 PIN 1. ANODE 1
 2. ANODE 1
 3. ANODE 1
 4. ANODE 1
 5. CATHODE, COMMON
 6. CATHODE, COMMON
 7. CATHODE, COMMON
 8. CATHODE, COMMON</p> | <p>STYLE 16:
 PIN 1. EMITTER, DIE #1
 2. BASE, DIE #1
 3. EMITTER, DIE #2
 4. BASE, DIE #2
 5. COLLECTOR, DIE #2
 6. COLLECTOR, DIE #2
 7. COLLECTOR, DIE #1
 8. COLLECTOR, DIE #1</p> |
| <p>STYLE 17:
 PIN 1. VCC
 2. V2OUT
 3. V1OUT
 4. TXE
 5. RXE
 6. VEE
 7. GND
 8. ACC</p> | <p>STYLE 18:
 PIN 1. ANODE
 2. ANODE
 3. SOURCE
 4. GATE
 5. DRAIN
 6. DRAIN
 7. CATHODE
 8. CATHODE</p> | <p>STYLE 19:
 PIN 1. SOURCE 1
 2. GATE 1
 3. SOURCE 2
 4. GATE 2
 5. DRAIN 2
 6. MIRROR 2
 7. DRAIN 1
 8. MIRROR 1</p> | <p>STYLE 20:
 PIN 1. SOURCE (N)
 2. GATE (N)
 3. SOURCE (P)
 4. GATE (P)
 5. DRAIN
 6. DRAIN
 7. DRAIN
 8. DRAIN</p> |
| <p>STYLE 21:
 PIN 1. CATHODE 1
 2. CATHODE 2
 3. CATHODE 3
 4. CATHODE 4
 5. CATHODE 5
 6. COMMON ANODE
 7. COMMON ANODE
 8. CATHODE 6</p> | <p>STYLE 22:
 PIN 1. I/O LINE 1
 2. COMMON CATHODE/VCC
 3. COMMON CATHODE/VCC
 4. I/O LINE 3
 5. COMMON ANODE/GND
 6. I/O LINE 4
 7. I/O LINE 5
 8. COMMON ANODE/GND</p> | <p>STYLE 23:
 PIN 1. LINE 1 IN
 2. COMMON ANODE/GND
 3. COMMON ANODE/GND
 4. LINE 2 IN
 5. LINE 2 OUT
 6. COMMON ANODE/GND
 7. COMMON ANODE/GND
 8. LINE 1 OUT</p> | <p>STYLE 24:
 PIN 1. BASE
 2. EMITTER
 3. COLLECTOR/ANODE
 4. COLLECTOR/ANODE
 5. CATHODE
 6. CATHODE
 7. COLLECTOR/ANODE
 8. COLLECTOR/ANODE</p> |
| <p>STYLE 25:
 PIN 1. VIN
 2. N/C
 3. REXT
 4. GND
 5. IOUT
 6. IOUT
 7. IOUT
 8. IOUT</p> | <p>STYLE 26:
 PIN 1. GND
 2. dv/dt
 3. ENABLE
 4. ILIMIT
 5. SOURCE
 6. SOURCE
 7. SOURCE
 8. VCC</p> | <p>STYLE 27:
 PIN 1. ILIMIT
 2. OVLO
 3. UVLO
 4. INPUT+
 5. SOURCE
 6. SOURCE
 7. SOURCE
 8. DRAIN</p> | <p>STYLE 28:
 PIN 1. SW_TO_GND
 2. DASIC OFF
 3. DASIC_SW_DET
 4. GND
 5. V_MON
 6. VBULK
 7. VBULK
 8. VIN</p> |
| <p>STYLE 29:
 PIN 1. BASE, DIE #1
 2. EMITTER, #1
 3. BASE, #2
 4. EMITTER, #2
 5. COLLECTOR, #2
 6. COLLECTOR, #2
 7. COLLECTOR, #1
 8. COLLECTOR, #1</p> | <p>STYLE 30:
 PIN 1. DRAIN 1
 2. DRAIN 1
 3. GATE 2
 4. SOURCE 2
 5. SOURCE 1/DRAIN 2
 6. SOURCE 1/DRAIN 2
 7. SOURCE 1/DRAIN 2
 8. GATE 1</p> | | |

DOCUMENT NUMBER:	98ASB42564B	Electronic versions are uncontrolled except when accessed directly from the Document Repository. Printed versions are uncontrolled except when stamped "CONTROLLED COPY" in red.
DESCRIPTION:	SOIC-8 NB	PAGE 2 OF 2

onsemi and **ONSEMI** are trademarks of Semiconductor Components Industries, LLC dba **onsemi** or its subsidiaries in the United States and/or other countries. **onsemi** reserves the right to make changes without further notice to any products herein. **onsemi** makes no warranty, representation or guarantee regarding the suitability of its products for any particular purpose, nor does **onsemi** assume any liability arising out of the application or use of any product or circuit, and specifically disclaims any and all liability, including without limitation special, consequential or incidental damages. **onsemi** does not convey any license under its patent rights nor the rights of others.

onsemi, **Onsemi**, and other names, marks, and brands are registered and/or common law trademarks of Semiconductor Components Industries, LLC dba "**onsemi**" or its affiliates and/or subsidiaries in the United States and/or other countries. **onsemi** owns the rights to a number of patents, trademarks, copyrights, trade secrets, and other intellectual property. A listing of **onsemi**'s product/patent coverage may be accessed at www.onsemi.com/site/pdf/Patent-Marking.pdf. **onsemi** reserves the right to make changes at any time to any products or information herein, without notice. The information herein is provided "as-is" and **onsemi** makes no warranty, representation or guarantee regarding the accuracy of the information, product features, availability, functionality, or suitability of its products for any particular purpose, nor does **onsemi** assume any liability arising out of the application or use of any product or circuit, and specifically disclaims any and all liability, including without limitation special, consequential or incidental damages. Buyer is responsible for its products and applications using **onsemi** products, including compliance with all laws, regulations and safety requirements or standards, regardless of any support or applications information provided by **onsemi**. "Typical" parameters which may be provided in **onsemi** data sheets and/or specifications can and do vary in different applications and actual performance may vary over time. All operating parameters, including "Typicals" must be validated for each customer application by customer's technical experts. **onsemi** does not convey any license under any of its intellectual property rights nor the rights of others. **onsemi** products are not designed, intended, or authorized for use as a critical component in life support systems or any FDA Class 3 medical devices or medical devices with a same or similar classification in a foreign jurisdiction or any devices intended for implantation in the human body. Should Buyer purchase or use **onsemi** products for any such unintended or unauthorized application, Buyer shall indemnify and hold **onsemi** and its officers, employees, subsidiaries, affiliates, and distributors harmless against all claims, costs, damages, and expenses, and reasonable attorney fees arising out of, directly or indirectly, any claim of personal injury or death associated with such unintended or unauthorized use, even if such claim alleges that **onsemi** was negligent regarding the design or manufacture of the part. **onsemi** is an Equal Opportunity/Affirmative Action Employer. This literature is subject to all applicable copyright laws and is not for resale in any manner.

ADDITIONAL INFORMATION

TECHNICAL PUBLICATIONS:

Technical Library: www.onsemi.com/design/resources/technical-documentation
onsemi Website: www.onsemi.com

ONLINE SUPPORT: www.onsemi.com/support

For additional information, please contact your local Sales Representative at www.onsemi.com/support/sales

Looking for pricing, stock, or lifecycle information?

Click below to explore more details on WIN SOURCE:

 [View NCS2553DG on WIN SOURCE](#)

 [ON Semiconductor](#) Information

Optimize Your Supply Chain with WIN SOURCE Solutions

-  Global Sourcing Solution
-  Obsolete Management
-  Cost Control Management
-  Shortage Management
-  Alternative Solution
-  Excess Inventory Management