



**THE DATASHEET OF
MMT08B310T3G**



MMT08B310T3

Preferred Devices

Thyristor Surge Protectors

High Voltage Bidirectional TSPD

These Thyristor Surge Protective devices (TSPD) prevent overvoltage damage to sensitive circuits by lightning, induction and power line crossings. They are breakover-triggered crowbar protectors. Turn-off occurs when the surge current falls below the holding current value.

- High Surge Current Capability: 80 Amps 10 x 1000 μ sec, for Controlled Temperature Environments
- The MMT08B310 is used to help equipment meet various regulatory requirements including: Bellcore 1089, ITU K.20 & K.21, IEC 950, UL 1459 & 1950 and FCC Part 68.
- Bidirectional Protection in a Single Device
- Little Change of Voltage Limit with Transient Amplitude or Rate
- Freedom from Wearout Mechanisms Present in Non-Semiconductor Devices
- Fail-Safe, Shorts When Overstressed, Preventing Continued Unprotected Operation
- Surface Mount Technology (SMT)
-  Indicates UL Registered – File #E210057
- Pb-Free Package is Available

MAXIMUM RATINGS ($T_J = 25^\circ\text{C}$ unless otherwise noted)

Rating	Symbol	Value	Unit
Off-State Voltage – Maximum MMT08B310T3	V_{DM}	± 270	V
Maximum Pulse Surge Short Circuit Current Non-Repetitive Double Exponential Decay Waveform (Notes 1 and 2) 10 x 1000 μ sec (–25°C Initial Temperature)	I_{PPS1}	± 80	A(pk)
8 x 20 μ sec	I_{PPS2}	± 250	
10 x 160 μ sec	I_{PPS3}	± 150	
10 x 560 μ sec	I_{PPS4}	± 100	
Maximum Non-Repetitive Rate of Change of On-State Current Double Exponential Waveform, $R = 1.0$, $L = 1.5 \mu\text{H}$, $C = 1.67 \mu\text{F}$, $I_{pk} = 110\text{A}$	di/dt	± 150	A/ μ s

Maximum ratings are those values beyond which device damage can occur. Maximum ratings applied to the device are individual stress limit values (not normal operating conditions) and are not valid simultaneously. If these limits are exceeded, device functional operation is not implied, damage may occur and reliability may be affected.

1. Allow cooling before testing second polarity.
2. Measured under pulse conditions to reduce heating.



ON Semiconductor®

<http://onsemi.com>

BIDIRECTIONAL TSPD (⚡)
80 AMP SURGE
310 VOLTS

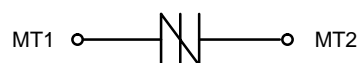

SMB
(No Polarity)
(Essentially JEDEC DO-214AA)
CASE 403C

MARKING DIAGRAM



RPCJ = Specific Device Code
A = Assembly Location
Y = Year
WW = Work Week
▪ = Pb-Free Package
(Note: Microdot may be in either location)

ORDERING INFORMATION

Device	Package	Shipping†
MMT08B310T3	SMB	2500 Tape & Reel
MMT08B310T3G	SMB Pb-Free	2500 Tape & Reel

†For information on tape and reel specifications, including part orientation and tape sizes, please refer to our Tape and Reel Packaging Specifications Brochure, BRD8011/D.

Preferred devices are recommended choices for future use and best overall value.

MMT08B310T3

THERMAL CHARACTERISTICS

Characteristic	Symbol	Max	Unit
Operating Temperature Range Blocking or Conducting State	T_{J1}	-40 to +125	°C
Overload Junction Temperature – Maximum Conducting State Only	T_{J2}	+175	°C
Instantaneous Peak Power Dissipation ($I_{pk} = 50$ A, 10x1000 μ sec @ 25°C)	P_{PK}	2000	W
Maximum Lead Temperature for Soldering Purposes 1/8" from Case for 10 Seconds	T_L	260	°C

ELECTRICAL CHARACTERISTICS ($T_J = 25^\circ\text{C}$ unless otherwise noted)

Devices are bidirectional. All electrical parameters apply to forward and reverse polarities.

Characteristics	Symbol	Min	Typ	Max	Unit
Breakover Voltage (Both polarities) ($dv/dt = 100$ V/ μ s, $I_{SC} = 1.0$ A, $V_{dc} = 1000$ V) (+65°C)	$V_{(BO)}$	-	-	365	V
		-	-	400	
Breakover Voltage (Both polarities) ($f = 60$ Hz, $I_{SC} = 1.0$ A(rms), $V_{OC} = 1000$ V(rms), $R_I = 1.0$ k Ω , $t = 0.5$ cycle) (Note 3) (+65°C)	$V_{(BO)}$	-	-	365	V
		-	-	400	
Breakover Voltage Temperature Coefficient	$dV_{(BO)}/dT_J$	-	0.08	-	%/°C
Breakdown Voltage ($I_{(BR)} = 1.0$ mA) Both polarities	$V_{(BR)}$	-	310	-	V
Off State Current ($V_{D1} = 50$ V) Both polarities ($V_{D2} = V_{DM}$) Both polarities	I_{D1} I_{D2}	-	-	2.0 5.0	μ A
On-State Voltage ($I_T = 1.0$ A) ($PW \leq 300$ μ s, Duty Cycle $\leq 2\%$) (Note 3)	V_T	-	1.53	3.0	V
Breakover Current ($f = 60$ Hz, $V_{DM} = 1000$ V(rms), $R_S = 1.0$ k Ω) Both polarities	I_{BO}	-	230	-	mA
Holding Current (Both polarities) (Note 3) $V_S = 500$ Volts; I_T (Initiating Current) = ± 1.0 Amp	I_H	150	340	-	mA
Critical Rate of Rise of Off-State Voltage (Linear waveform, $V_D = \text{Rated } V_{BR}$, $T_J = 25^\circ\text{C}$)	dv/dt	2000	-	-	V/ μ s
Capacitance ($f = 1.0$ MHz, 50 Vdc, 1.0 V rms Signal) ($f = 1.0$ MHz, 2.0 Vdc, 1.0 V rms Signal)	C_O	-	23 -	25 50	pF

3. Measured under pulse conditions to reduce heating.

Voltage Current Characteristic of TSPD (Bidirectional Device)

Symbol	Parameter
I_{D1}, I_{D2}	Off State Leakage Current
V_{D1}, V_{D2}	Off State Blocking Voltage
V_{BR}	Breakdown Voltage
V_{BO}	Breakover Voltage
I_{BO}	Breakover Current
I_H	Holding Current
V_{TM}	On State Voltage

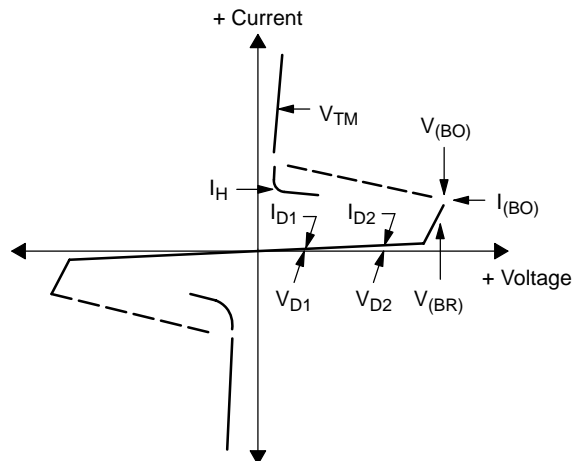

MMT08B310T3

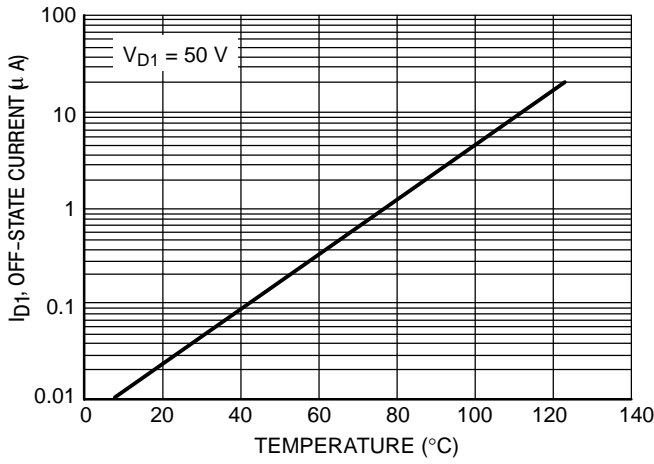

Figure 1. Off-State Current versus Temperature

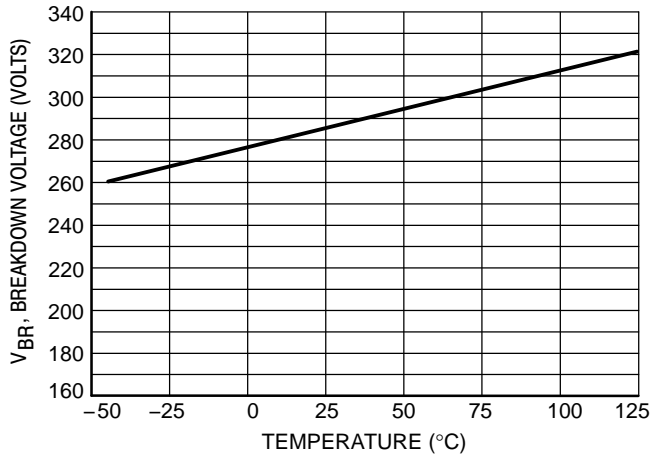

Figure 2. Breakdown Voltage versus Temperature

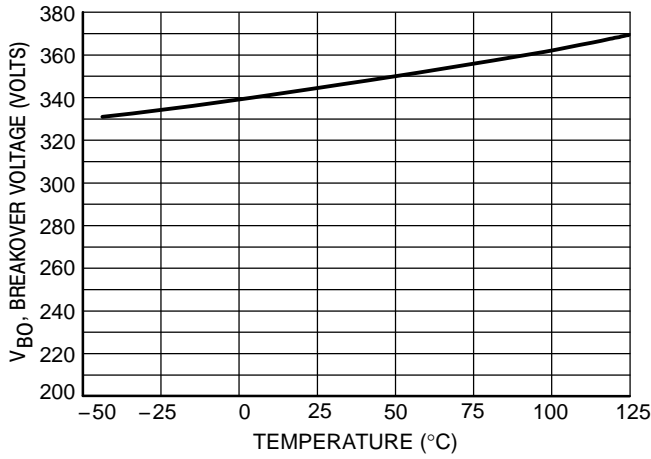

Figure 3. Breakover Voltage versus Temperature

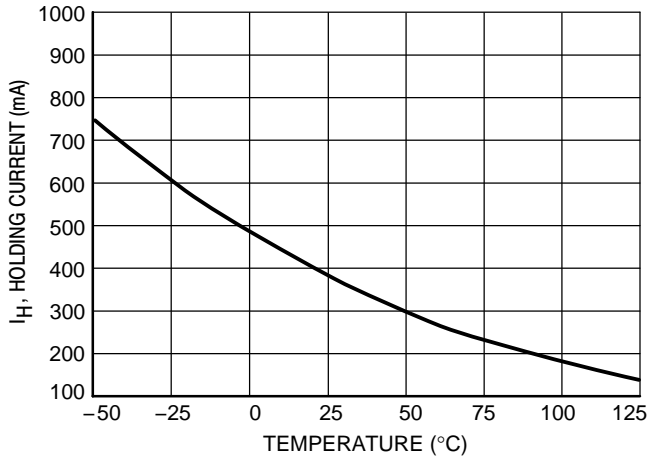

Figure 4. Holding Current versus Temperature

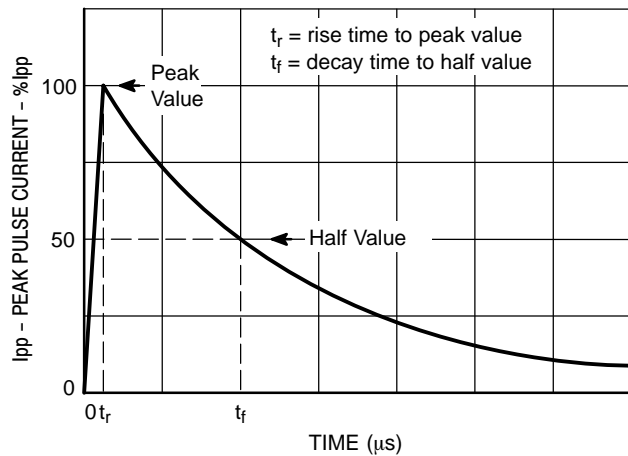

Figure 5. Exponential Decay Pulse Waveform

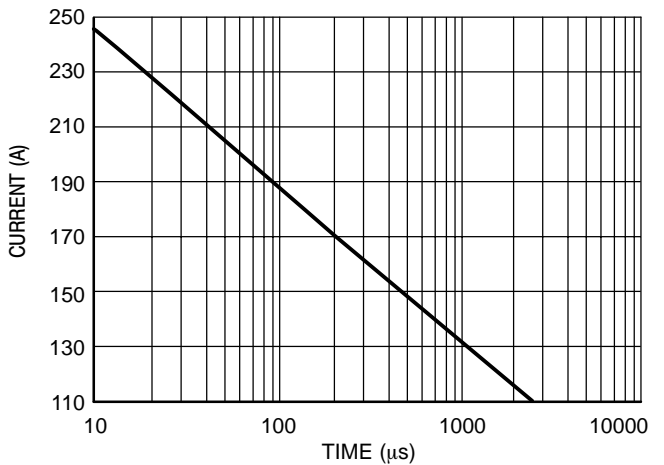
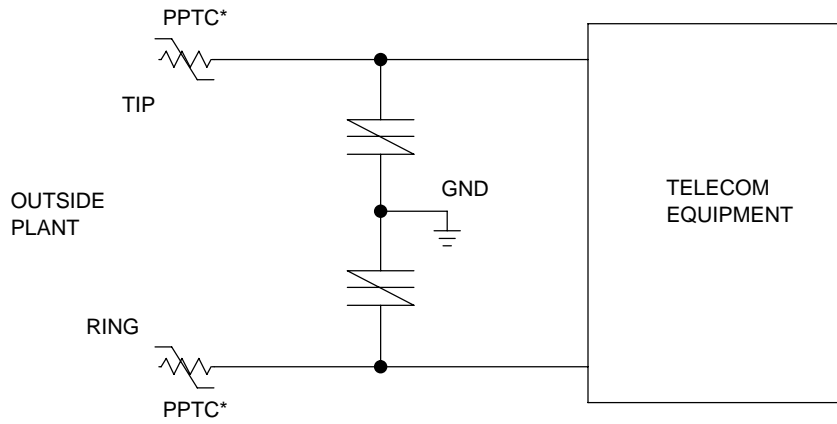
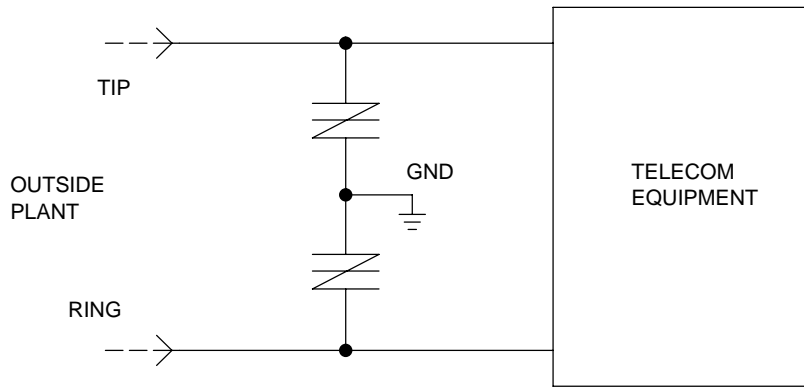
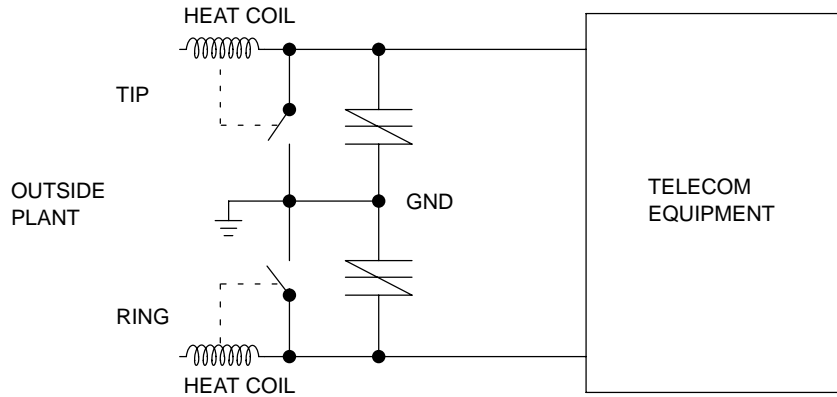

Figure 6. Peak Surge On-State Current versus Surge Current Duration, Sinusoidal Waveform

MMT08B310T3



*Polymeric PTC (positive temperature coefficient) overcurrent protection device



MMT08B310T3

PACKAGE DIMENSIONS

SMB
 (No Polarity)
 (Essentially JEDEC DO-214AA)
 CASE 403C-01
 ISSUE A

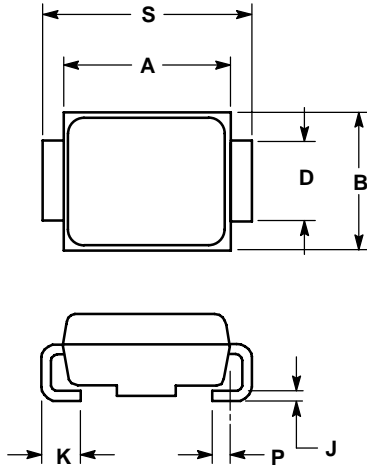

- NOTES:
1. DIMENSIONING AND TOLERANCING PER ANSI Y14.5M, 1982.
 2. CONTROLLING DIMENSION: INCH.
 3. D DIMENSION SHALL BE MEASURED WITHIN DIMENSION P.

DIM	INCHES		MILLIMETERS	
	MIN	MAX	MIN	MAX
A	0.160	0.180	4.06	4.57
B	0.130	0.150	3.30	3.81
C	0.075	0.095	1.90	2.41
D	0.077	0.083	1.96	2.11
H	0.0020	0.0060	0.051	0.152
J	0.006	0.012	0.15	0.30
K	0.030	0.050	0.76	1.27
P	0.020 REF		0.51 REF	
S	0.205	0.220	5.21	5.59

SOLDERING FOOTPRINT*

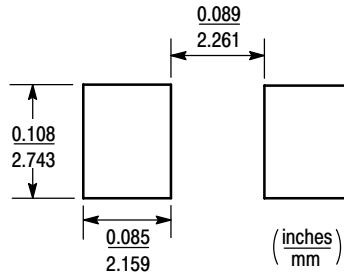

*For additional information on our Pb-Free strategy and soldering details, please download the ON Semiconductor Soldering and Mounting Techniques Reference Manual, SOLDERRM/D.

ON Semiconductor and **ON** are registered trademarks of Semiconductor Components Industries, LLC (SCILLC). SCILLC reserves the right to make changes without further notice to any products herein. SCILLC makes no warranty, representation or guarantee regarding the suitability of its products for any particular purpose, nor does SCILLC assume any liability arising out of the application or use of any product or circuit, and specifically disclaims any and all liability, including without limitation special, consequential or incidental damages. "Typical" parameters which may be provided in SCILLC data sheets and/or specifications can and do vary in different applications and actual performance may vary over time. All operating parameters, including "Typicals" must be validated for each customer application by customer's technical experts. SCILLC does not convey any license under its patent rights nor the rights of others. SCILLC products are not designed, intended, or authorized for use as components in systems intended for surgical implant into the body, or other applications intended to support or sustain life, or for any other application in which the failure of the SCILLC product could create a situation where personal injury or death may occur. Should Buyer purchase or use SCILLC products for any such unintended or unauthorized application, Buyer shall indemnify and hold SCILLC and its officers, employees, subsidiaries, affiliates, and distributors harmless against all claims, costs, damages, and expenses, and reasonable attorney fees arising out of, directly or indirectly, any claim of personal injury or death associated with such unintended or unauthorized use, even if such claim alleges that SCILLC was negligent regarding the design or manufacture of the part. SCILLC is an Equal Opportunity/Affirmative Action Employer. This literature is subject to all applicable copyright laws and is not for resale in any manner.

PUBLICATION ORDERING INFORMATION

LITERATURE FULFILLMENT:

Literature Distribution Center for ON Semiconductor
P.O. Box 61312, Phoenix, Arizona 85082-1312 USA
Phone: 480-829-7710 or 800-344-3860 Toll Free USA/Canada
Fax: 480-829-7709 or 800-344-3867 Toll Free USA/Canada
Email: orderlit@onsemi.com

N. American Technical Support: 800-282-9855 Toll Free
USA/Canada

Japan: ON Semiconductor, Japan Customer Focus Center
2-9-1 Kamimeguro, Meguro-ku, Tokyo, Japan 153-0051
Phone: 81-3-5773-3850



ON Semiconductor Website: <http://onsemi.com>

Order Literature: <http://www.onsemi.com/litorder>

For additional information, please contact your local Sales Representative.

Looking for pricing, stock, or lifecycle information?

Click below to explore more details on WIN SOURCE:

-  [View MMT08B310T3G on WIN SOURCE](#)
-  [ON Semiconductor Information](#)

Optimize Your Supply Chain with WIN SOURCE Solutions

-  Global Sourcing Solution
-  Obsolete Management
-  Cost Control Management
-  Shortage Management
-  Alternative Solution
-  Excess Inventory Management