



**THE DATASHEET OF  
TPS65562RGTR**



## INTEGRATED PHOTO FLASH CHARGER AND IGBT DRIVER

### FEATURES

- High Integrated Solution to Reduce Components
- Integrated Voltage Reference
- Integrated 50-V Power Switch
- Integrated Insulated Gated BiPolar Transistor (IGBT) Driver
- High Efficiency
- Programmable Peak Current, 0.9 A ~ 1.8 A
- Input Voltage of 1.6 V to 12 V
- Optimized Control Loop for Fast Charge Time
- Isolate IGBT VCC from VCC
- Output Voltage Feedback From Primary Side
- 16-pin QFN Package
- Protection
  - MAX On Time
  - MAX Off Time
  - Over Current Shutdown to Monitor VDS at SW Pin (OVDS)
  - Thermal Disable

### APPLICATIONS

- Digital Still Cameras
- Optical Film Cameras

### DESCRIPTION/ORDERING INFORMATION

This device offers a complete solution for charging photo flash capacitor from battery input, and subsequently discharging the capacitor to a xenon flash tube. This device has an integrated voltage reference, power switch, IGBT driver, and control logic blocks for charging applications and driving IGBT application. Compared with discrete solutions, this device reduces the component count, shrinks the solution size, and eases designs for xenon tube application. Additional advantages are a fast charging time and high efficiency from an optimized pulse width modulation (PWM) control algorithm.

Other provisions of the device includes sensing the output voltage from the primary side, programmable peak current, thermal shutdown, an output pin for charge completion, and input pins for charge enable and flash enable.

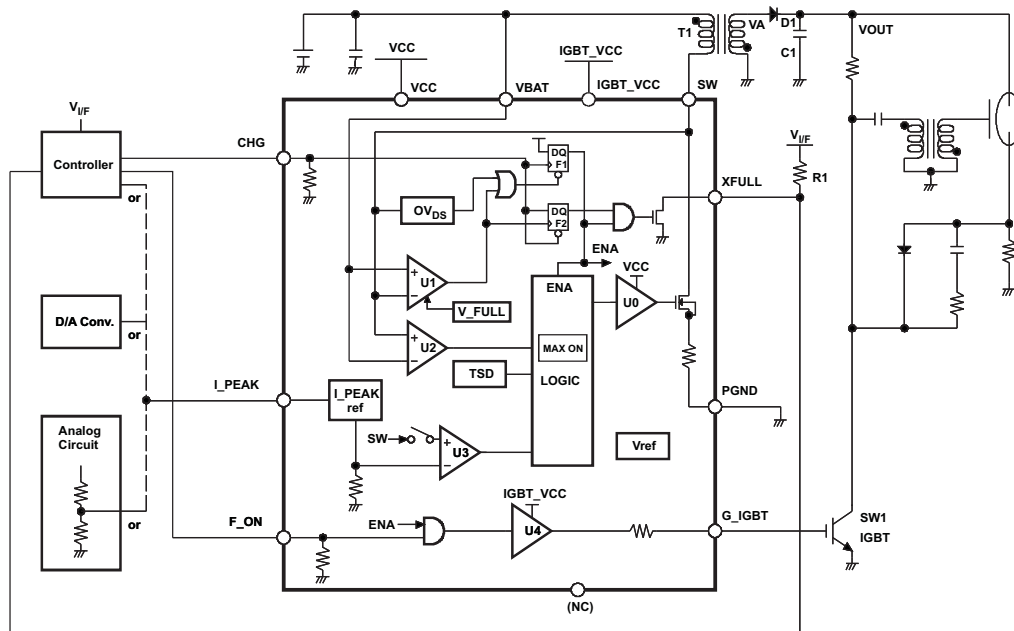

**Figure 1. Typical Application Circuit**



Please be aware that an important notice concerning availability, standard warranty, and use in critical applications of Texas Instruments semiconductor products and disclaimers thereto appears at the end of this data sheet.

PowerPAD is a trademark of Texas Instruments.



These devices have limited built-in ESD protection. The leads should be shorted together or the device placed in conductive foam during storage or handling to prevent electrostatic damage to the MOS gates.

**ORDERING INFORMATION**

T <sub>A</sub>	PACKAGE <sup>(1)</sup>	ORDERABLE PART NUMBER	TOP-SIDE MARKING
–35°C to 85°C	CAH	16-pin QFN	TPS65562RGT

(1) Package drawings, standard packing quantities, thermal data, symbolization, and PCB design guidelines are available at [www.ti.com/sc/package](http://www.ti.com/sc/package).

**ABSOLUTE MAXIMUM RATINGS<sup>(1)</sup>**

over operating free-air temperature range (unless otherwise noted)

			UNIT
Supply voltage	VCC, IGBT_VCC	–0.6 to 6	V
	VBAT	–0.6 to 13	
V <sub>SW</sub>	Switch terminal voltage	–0.6 to 50	V
I <sub>SW</sub>	Switch current between SW and PGND	3	A
V <sub>I</sub>	Input voltage of CHG, I_PEAK, F_ON	–0.3 to V <sub>CC</sub>	V
T <sub>stg</sub>	Storage temperature	–40 to 150	°C
T <sub>J</sub>	Maximum junction temperature	125	°C
ESD rating	HBM (Human Body Model) JEDEC JES22-A114	1	kV

(1) Stresses beyond those listed under "absolute maximum ratings" may cause permanent damage to the device. These are stress ratings only, and functional operation of the device at these or any other conditions beyond those indicated under "recommended operating conditions" is not implied. Exposure to absolute-maximum-rated conditions for extended periods may affect device reliability.

**RECOMMENDED OPERATING CONDITIONS**

		MIN	MAX	UNIT
Supply voltage	VCC	2.7	4	V
	IGBT_VCC	2.7	5.5	
	VBAT	1.6	12	
V <sub>SW</sub>	Switch terminal voltage	–0.3	45	V
I <sub>SW</sub>	Switch current between SW and PGND		2	A
Operating free-air temperature range		–35	85	°C
V <sub>IH</sub>	High-level digital input voltage at CHG and F_ON	2		V
V <sub>IL</sub>	Low-level digital input voltage at CHG and F_ON		0.5	V

**DISSIPATION RATINGS**

PACKAGE	R <sub>θJA</sub> <sup>(1)</sup>	POWER RATINGS T <sub>A</sub> < 25°C	POWER RATINGS RATE T <sub>A</sub> = 70°C	POWER RATINGS RATE T <sub>A</sub> = 85°C
QFN	47.4°C/W	2.11 W	1.16 W	844 mW

(1) The thermal resistance, R<sub>θJA</sub>, is based on a soldered PowerPAD™ package on 2S2P JEDEC board using thermal vias.

## ELECTRICAL CHARACTERISTICS

 $T_A = 25^\circ\text{C}$ ,  $V_{BAT} = 4.2\text{ V}$ ,  $V_{CC} = 3\text{ V}$ ,  $I_{GBT\_VCC} = 3\text{ V}$ ,  $V_{(SW)} = 4.2\text{ V}$  (unless otherwise noted)

PARAMETER		TEST CONDITIONS	MIN	TYP	MAX	UNIT
$R_{ONL}$	ON resistance of XFULL	$I_{XFULL} = -1\text{ mA}$		1.5	3	$k\Omega$
$V_{PKH}^{(1)}$	Upper threshold voltage of $I_{PEAK}$	$V_{CC} = 3\text{ V}$	2.4			V
$V_{PKL}^{(1)}$	Lower threshold voltage of $I_{PEAK}$	$V_{CC} = 3\text{ V}$			0.6	V
$I_{CC1}$	Supply current from VBAT	CHG = H, $V_{SW} = 0\text{ V}$ (free run by $t_{MAX}$ )		17	50	$\mu\text{A}$
$I_{CC2}$	Supply current from VCC	CHG = H, $V_{SW} = 0\text{ V}$ (free run by $t_{MAX}$ )		1.3	3	mA
$I_{CC3}$	Supply current from VCC and VBAT	CHG = L			1	$\mu\text{A}$
$I_{LKG1}$	Leakage current of SW terminal				2	$\mu\text{A}$
$I_{LKG2}$	Leakage current of XFULL terminal	$V_{XFULL} = 5\text{ V}$			1	$\mu\text{A}$
$I_{sink}$	Sink current at $I_{PEAK}$	$V_{I\_PEAK} = 3\text{ V}$ , CHG: High			2	$\mu\text{A}$
		$V_{I\_PEAK} = 3\text{ V}$ , CHG: Low			0.1	
$R_{ONSW}$	SW ON resistance between SW and PGND	$I_{SW} = 1\text{ A}$ , $V_{CC} = 3\text{ V}$		0.4	0.9	$\Omega$
$R_{IGBT1}$	G_IGBT pull up resistance	$V_{G\_IGBT} = 0\text{ V}$ , $I_{GBT\_VCC} = 3\text{ V}$	8	12	19.4	$\Omega$
$R_{IGBT2}$	G_IGBT pull down resistance	$V_{G\_IGBT} = 3\text{ V}$ , $I_{GBT\_VCC} = 3\text{ V}$	36	53	70	$\Omega$
$I_{PEAK1}$	Upper peak of ISW	$V_{I\_PEAK} = 3\text{ V}$	1.58	1.68	1.78	A
$I_{PEAK2}$	Lower peak of ISW	$V_{I\_PEAK} = 0\text{ V}$	0.7	0.8	0.9	A
$V_{FULL}$	Charge completion detect voltage at V(SW)	$V_{BAT} = 1.6\text{ V}$ , $V_{CC} = 3\text{ V}$	28.0	28.7	29.4	V
		$V_{CC} = 3\text{ V}$	28.6	29.0	29.4	V
$V_{ZERO}$	Zero current detection at VSW		1	20	60	mV
$T_{SD}^{(1)}$	Thermal shutdown temperature		150	160	170	$^\circ\text{C}$
$O_{VDS}$	Over current detection at VSW		0.95	1.2	1.45	V
$T_{MIX}$	MAX OFF time		25	50	80	$\mu\text{s}$
$T_{MAX}$	MAX ON time		50	100	160	$\mu\text{s}$
$R_{INPD}$	Pull down resistance of CHG, F_ON	$V_{CHG} = V_{F\_ON} = 4.2\text{ V}$		100		$k\Omega$

(1) Specified by design

## SWITCHING CHARACTERISTICS

 $T_A = 25^\circ\text{C}$ ,  $V_{BAT} = 4.2\text{ V}$ ,  $V_{CC} = 3\text{ V}$ ,  $I_{GBT\_VCC} = 3\text{ V}$ ,  $V_{SW} = 4.2\text{ V}$  (unless otherwise noted)

PARAMETER		TEST CONDITIONS	MIN	TYP	MAX	UNIT
$t_{PD}^{(1)}$	Propagation delay	F_ON $\uparrow$ ↓ G_IGBT $\uparrow$ ↓		50		ns
		SW ON after VSW dips from $V_{ZERO}$		500		ns
		SW OFF after ISW exceeds $I_{PEAK}$		270		ns
		XFULL $\downarrow$ after VSW exceeds $V_{Full}$		400		ns
		SW ON after CHG $\uparrow$		12		$\mu\text{s}$
		SW OFF after CHG $\downarrow$		20		ns

(1) Specified by design

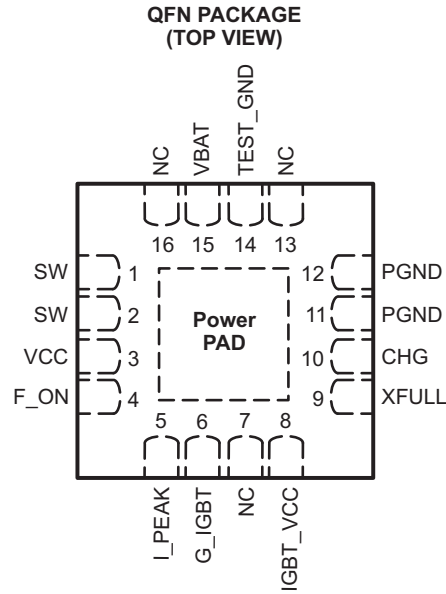

**TERMINAL FUNCTIONS**

TERMINAL		I/O	DESCRIPTION
NAME	NO.		
SW	1, 2	O	Primary side switch. Connect SW to the switched side of the transformer
VCC	3	I	Power supply input. Connect VCC to an input supply from 2.7 V to 4.0 V. Bypass VCC to GND with a 1 $\mu$ F ceramic capacitor as close as possible to the IC.
F_ON	4	I	G_IGBT control input. Drives F_ON with the flash discharge signal. A logic high on F_ON drives G_IGBT high when CHG is Low. See the <i>IGBT driver control</i> section for details.
I_PEAK	5	I	Primary side Peak current control input. The voltage at I_PEAK sets the peak current into SW. See the <i>Programming Peak Current</i> section for details on selecting $V_{I\_PEAK}$ .
G_IGBT	6	O	IGBT gate driver output. G_IGBT swings from PGND to VCC to drive external IGBT devices.
NC	7, 13, 16		No internal connection
IGBT_VCC	8	I	Power supply input for IGBT Driver output. Connect IGBT_VCC to an input supply from 2.7 V to 5.5 V.
XFULL	9	O	Charge completion indicator output. XFULL is an open-drain output that pulls low once the output is fully charged. XFULL is high impedance during charging and all fault conditions. XFULL is reset when CHG turns Low from High. See the <i>Indicating Charging status</i> section for details.
CHG	10	I	Charge control input. Drive CHG high to initiate charging of the output. Drive CHG low to terminate charging.
PGND	11, 12		Power ground. Connect to the ground plane.
TEST_GND	14		Used by TI, should be connected to PGND and ground plane.
VBAT	15	I	Battery voltage monitor input. Connect VBAT to an input supply from 1.6 V to 12 V. Bypass VBAT to GND with a 10 $\mu$ F ceramic capacitor (C1 in <a href="#">Figure 1</a> as close as possible to the battery) and a 1 $\mu$ F ceramic capacitor (C2 in <a href="#">Figure 1</a> , as close as possible to the IC). It is no problem to input VBAT before VCC input.

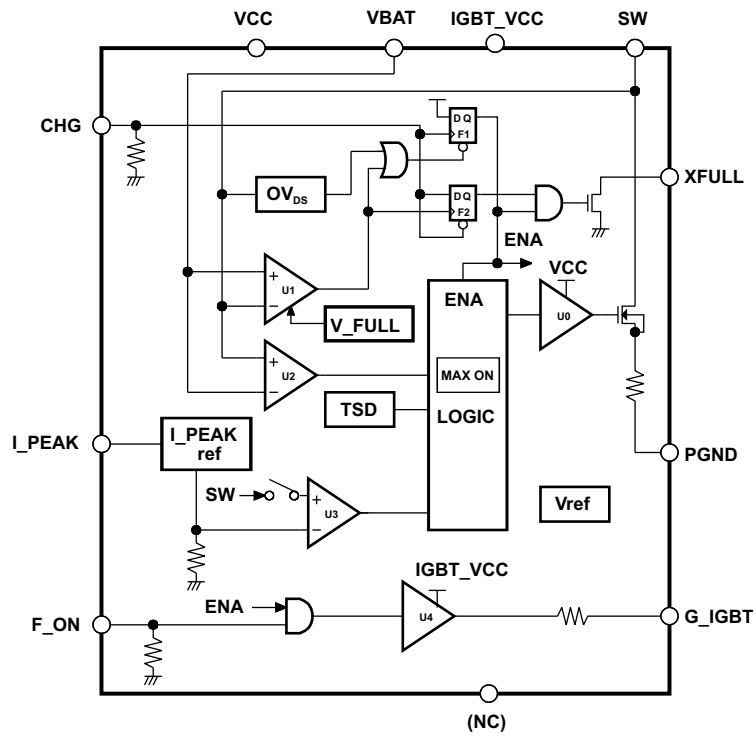

Figure 2. Block Diagram

I/O Equivalent Circuits

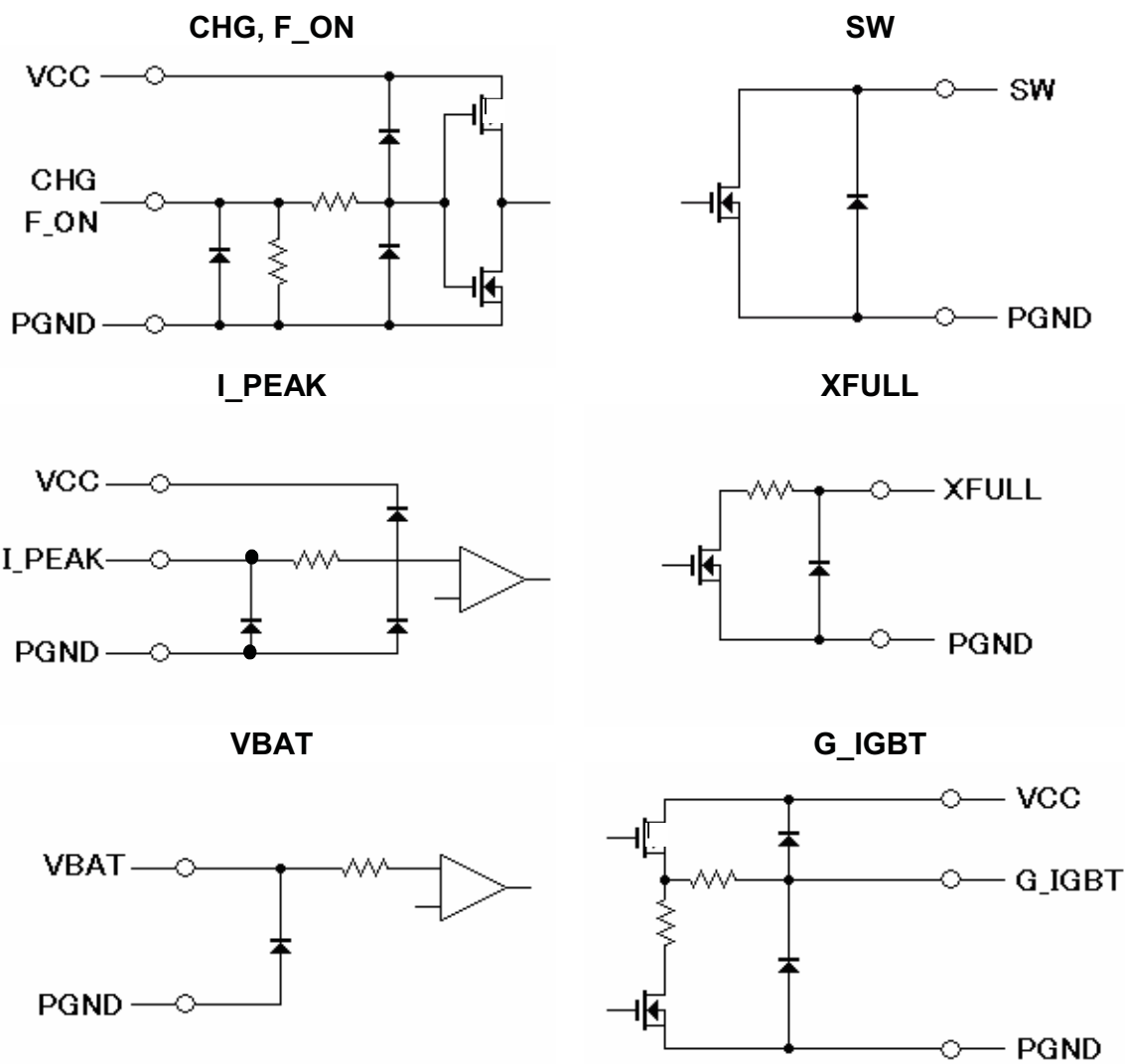
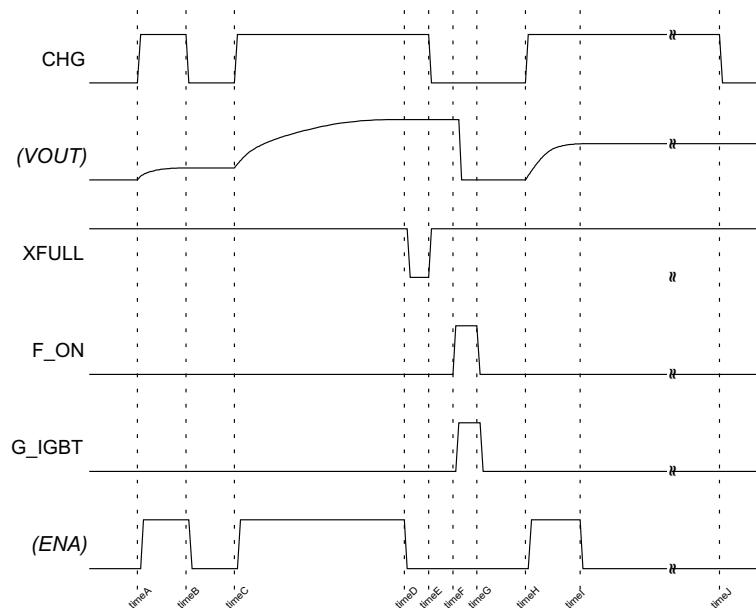

Figure 3. I/O Equivalent Circuits

## PRINCIPLES OF OPERATION



**Figure 4. Whole Operation Sequence Chart**

### Start/Stop Charging

TPS65562 has one internal enable latch, F1, that holds the charge enable (ON/OFF status) of the device (see [Figure 4](#)).

The only way to start charging is to input  $\text{CHG}\uparrow$  (see time A/C/H in [Figure 4](#)). Each time  $\text{CHG}\uparrow$  is applied, the TPS65562 starts charging.

There are three trigger events to stop charging:

1. Forced stop by inputting  $\text{CHG} = \text{L}$  from the controller (see timeB in [Figure 4](#)).
2. Automatic stop by detecting a full charge.  $\text{VOUT}$  reaches the target value (see TimeD in [Figure 4](#)).
3. Protected stop by detecting an overcurrent function (OVDS) trigger at SW pin (see TimeI in [Figure 4](#)).

### Indicate Charging Status

When the charging operation is complete, the TPS65562 drives the charge completion indicator pin, XFULL, to GND. A controller can detect the status of the device as a logic signal when connected through a pullup resistor, R1 (see [Figure 1](#)).

The XFULL output enables the controller to detect the OVDS protection status. If OVDS protection occurs, XFULL never goes L during  $\text{CHG} = \text{H}$ . Therefore, the controller detects OVDS protection by measuring the time from CHG high to XFULL low. If the time to XFULL low is longer than the maximum designed charge time, then an OVDS protection occurred.

The device starts charging at timeH, and OVDS protection occurs at TimeI (see [Figure 5](#)). At TimeI, XFULL stays H. At TimeJ, the controller detects OVDS protection through the expiration of a timer ends and then sets CHG to low to terminate the operation.

PRINCIPLES OF OPERATION (continued)

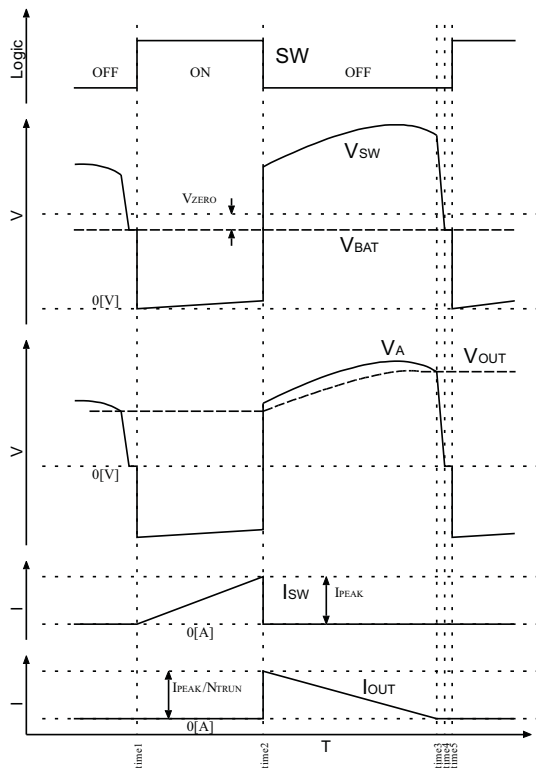

Figure 5. Timing Diagram at One Switching

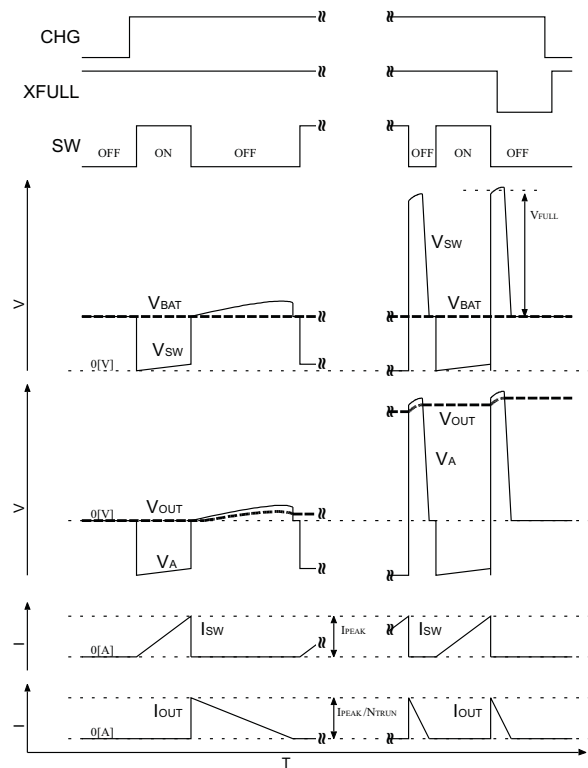

Figure 6. Timing Diagram at Beginning/Ending

Control Charging

The TPS65562 provides three comparators to control charging. Figure 2 shows the block diagram of TPS65562, and Figure 5 shows a timing diagram of one switch cycle. Note that emphasis is placed on Time1 and Time3 of the waveform in Figure 5.

While SW is ON (Time1 to Time2 in Figure 5), U3 monitors current flow through the integrated power switch from SW pin to GND. When I(SW) exceeds I(PEAK), SW turns OFF (Time2 in Figure 5).

When SW turns OFF (Time2 in Figure 5), the magnetic energy in the transformer starts discharging. Meanwhile, U2 monitors the kickback voltage at the SW terminal. As the energy is discharging, the kickback voltage is increasing according to the increase of VO (Time2 to Time3 in Figure 5). When almost all energy is discharged, the system cannot continue rectification via the diode, and the charging current of IO goes to zero (Times3 in Figure 5). After rectification stops, the small amount of energy left in the transformer is released via parasitic paths, and the kickback voltage reaches zero (Time3 to Time4 in Figure 5). During this period, U2 makes SW turn ON when (V(SW) - VBAT) dips from V(ZERO) (Time5 in Figure 5). In the actual circuit, the period between Time4 and Time5 in Figure 5 is small or does not appear dependent on the delay time of the U2 detection to SW ON.

U1 also monitors the kickback voltage. When (V(SW) - VBAT) exceeds V(FULL), the TPS65562 stops charging (see Figure 6).

In Figure 5 and Figure 6, ON time is always the same period in every switch cycle. The ON time is calculated by Equation 1. L and IPEAK are selected to ensure that tON does not exceed the MAX ON time (tMAX).

$$T_{ON} = L \frac{I_{PEAK}}{V_{BAT}} \tag{1}$$

The OFF time is dependant on output voltage. As the output voltage gets higher, the OFF time gets shorter (see Equation 2).

## PRINCIPLES OF OPERATION (continued)

$$T_{\text{OFF}} = N_{\text{TURN}} \times L \frac{I_{\text{PEAK}}}{V_{\text{OUT}}} \quad (2)$$

### Programming Peak Current

The TPS65562 provides a method to program the peak primary current with a voltage applied to the I\_PEAK pin. Figure 7 shows how to program I\_PEAK.

The I\_PEAK input is treated as a logic input below V\_PKL (0.6 V) and above V\_PKH (2.4 V). Between V\_PKL and V\_PKH, I\_PEAK input is treated as an analog input. Using this characteristic, I\_PEAK can be set by a logic signal or by an analog input.

Typical usages of this function are:

1. Setting the peak charging currents based on the battery voltage. Larger I\_PEAK for a fully charged battery and lower I\_PEAK for a discharged battery.
2. Reducing I\_PEAK when powering a zooming lens motor. This avoids inadvertent shutdowns due to large current from the battery.

In Figure 1, three optional connections to I\_PEAK are shown.

1. Use the controller to treat I\_PEAK as the logic input pin. This option is the easiest.
2. Use a D/A converter to force I\_PEAK to follow analog information, such as battery voltage.
3. Use an analog circuit to achieve the same results as the D/A converter.

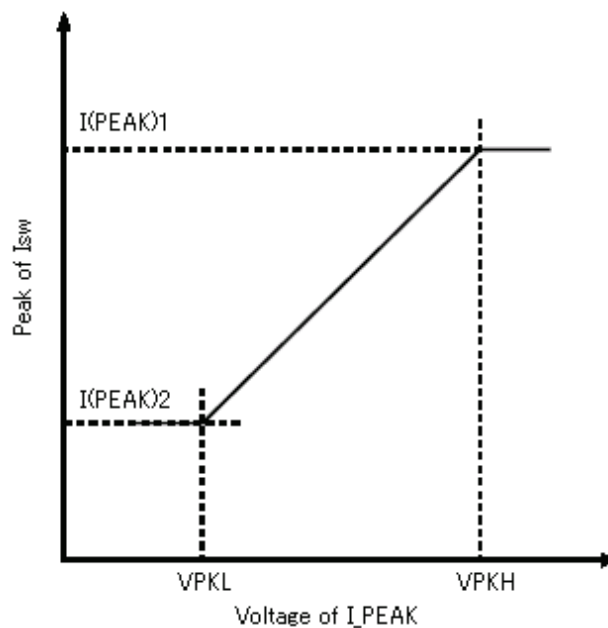
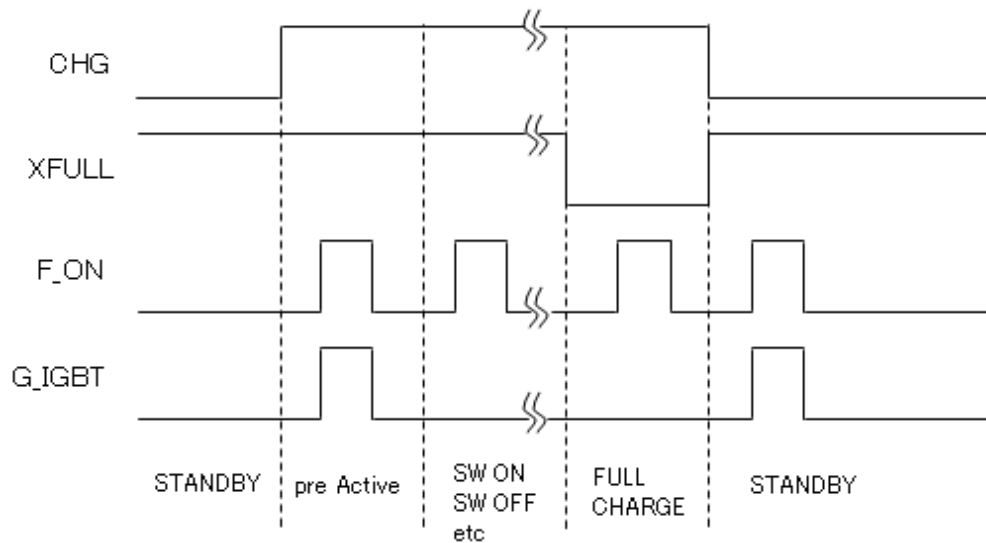

Figure 7. I\_PEAK vs I<sub>sw</sub>

### IGBT Driver Control

The IGBT driver is provided by the TPS65562. The driver voltage depends on VCC. TPS65562 has a mask filter as shown in Figure 8. The mask does not have hysteresis; therefore, there is no wait time from CHG forcing Low after FULL CHARGE to F\_ON turning High.

### PRINCIPLES OF OPERATION (continued)



**Figure 8. Relationships Between F\_ON and CHG**

### Protections

TPS65562 provides four protection mechanisms: max on time, max off time, thermal disable, and over current shutdown.

#### MAX ON TIME

To prevent a condition such as pulling current from a poor power source (i.e., an almost empty battery), and never reaching peak current, the TPS65562 provides a maximum ON time function. If the ON time exceeds  $t_{MAX}$ , the TPS5562 is forced OFF regardless of  $I_{PEAK}$  detection.

#### MAX OFF TIME

To prevent a condition such as never increasing the voltage at the SW pin when the internal FET is OFF, the TPS65562 provides a maximum OFF time function. If the OFF time exceeds  $t_{MIN}$ , the TPS65562 is forced ON regardless of  $V_{ZERO}$  detection.

#### THERMAL DISABLE

Once the die temperature of the TPS65562, reaches 160°C, all functions stop. Once the die cools below 160°C, the TPS65562 restarts charging if CHG remains high during the entire over temperature condition.

#### OVER CURRENT SHUTDOWN

The TPS65562 provides an over voltage monitor function of the SW pin. The TPS65562 is latched off if the voltage on the SW pin is above OVDS during the switch ON time (see [Figure 4](#) and its descriptions).

This function protects against short-circuits on the primary side of the transformer. A short-circuit of the primary side shorts the battery voltage to GND. SW pin can damage the device if not protected.

**PACKAGING INFORMATION**

Orderable Device	Status (1)	Package Type	Package Drawing	Pins	Package Qty	Eco Plan (2)	Lead/Ball Finish (6)	MSL Peak Temp (3)	Op Temp (°C)	Device Marking (4/5)	Samples
TPS65562RGTR	ACTIVE	QFN	RGT	16		TBD	Call TI	Call TI	-35 to 85	CAH	Samples

(1) The marketing status values are defined as follows:

**ACTIVE:** Product device recommended for new designs.

**LIFEBUY:** TI has announced that the device will be discontinued, and a lifetime-buy period is in effect.

**NRND:** Not recommended for new designs. Device is in production to support existing customers, but TI does not recommend using this part in a new design.

**PREVIEW:** Device has been announced but is not in production. Samples may or may not be available.

**OBSOLETE:** TI has discontinued the production of the device.

(2) Eco Plan - The planned eco-friendly classification: Pb-Free (RoHS), Pb-Free (RoHS Exempt), or Green (RoHS & no Sb/Br) - please check <http://www.ti.com/productcontent> for the latest availability information and additional product content details.

**TBD:** The Pb-Free/Green conversion plan has not been defined.

**Pb-Free (RoHS):** TI's terms "Lead-Free" or "Pb-Free" mean semiconductor products that are compatible with the current RoHS requirements for all 6 substances, including the requirement that lead not exceed 0.1% by weight in homogeneous materials. Where designed to be soldered at high temperatures, TI Pb-Free products are suitable for use in specified lead-free processes.

**Pb-Free (RoHS Exempt):** This component has a RoHS exemption for either 1) lead-based flip-chip solder bumps used between the die and package, or 2) lead-based die adhesive used between the die and leadframe. The component is otherwise considered Pb-Free (RoHS compatible) as defined above.

**Green (RoHS & no Sb/Br):** TI defines "Green" to mean Pb-Free (RoHS compatible), and free of Bromine (Br) and Antimony (Sb) based flame retardants (Br or Sb do not exceed 0.1% by weight in homogeneous material)

(3) MSL, Peak Temp. - The Moisture Sensitivity Level rating according to the JEDEC industry standard classifications, and peak solder temperature.

(4) There may be additional marking, which relates to the logo, the lot trace code information, or the environmental category on the device.

(5) Multiple Device Markings will be inside parentheses. Only one Device Marking contained in parentheses and separated by a "~" will appear on a device. If a line is indented then it is a continuation of the previous line and the two combined represent the entire Device Marking for that device.

(6) Lead/Ball Finish - Orderable Devices may have multiple material finish options. Finish options are separated by a vertical ruled line. Lead/Ball Finish values may wrap to two lines if the finish value exceeds the maximum column width.

**Important Information and Disclaimer:** The information provided on this page represents TI's knowledge and belief as of the date that it is provided. TI bases its knowledge and belief on information provided by third parties, and makes no representation or warranty as to the accuracy of such information. Efforts are underway to better integrate information from third parties. TI has taken and continues to take reasonable steps to provide representative and accurate information but may not have conducted destructive testing or chemical analysis on incoming materials and chemicals. TI and TI suppliers consider certain information to be proprietary, and thus CAS numbers and other limited information may not be available for release.

In no event shall TI's liability arising out of such information exceed the total purchase price of the TI part(s) at issue in this document sold by TI to Customer on an annual basis.



RGT (S-PVQFN-N16)

PLASTIC QUAD FLATPACK NO-LEAD

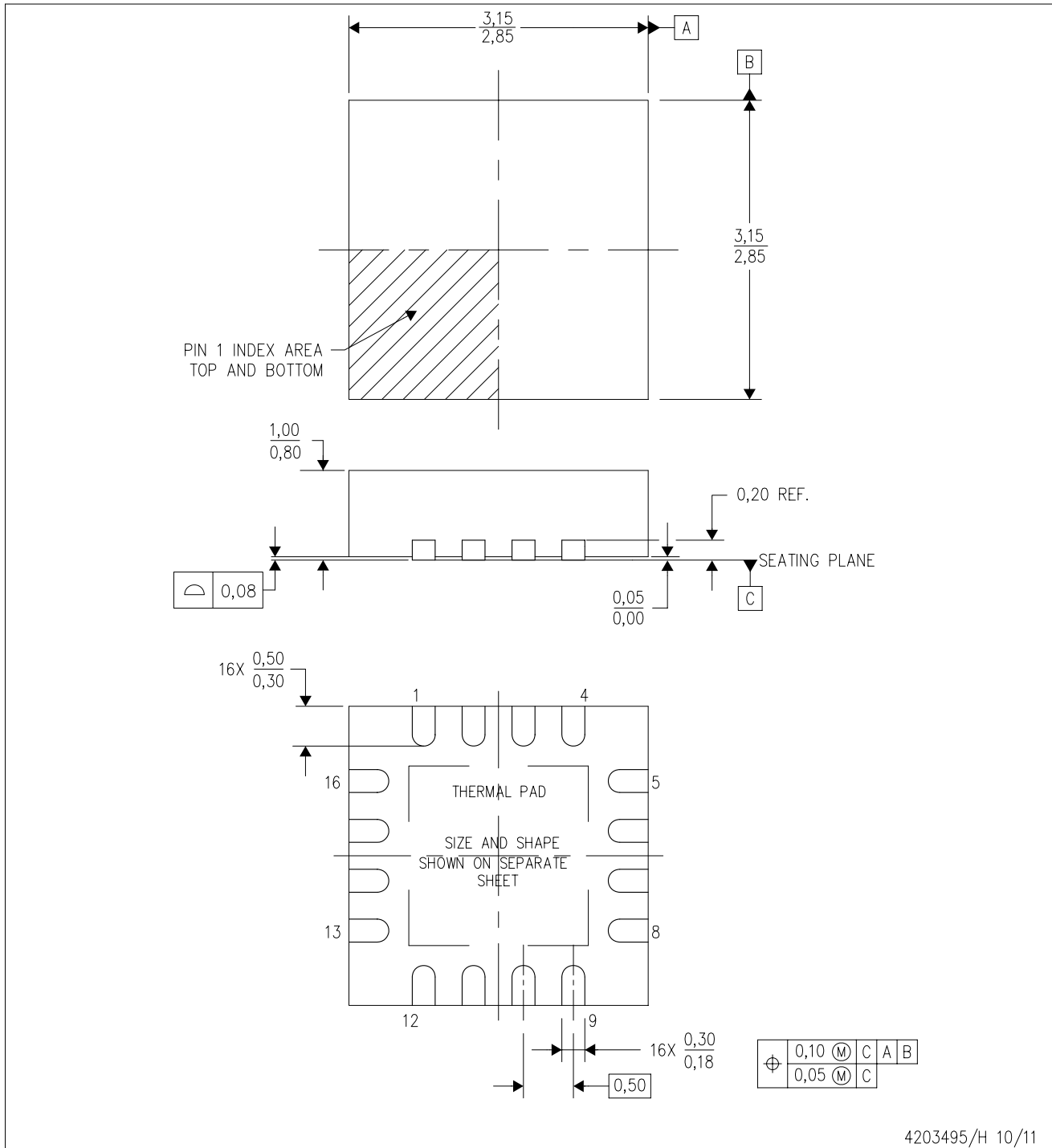

4203495/H 10/11

- NOTES:
- All linear dimensions are in millimeters. Dimensioning and tolerancing per ASME Y14.5M-1994.
  - This drawing is subject to change without notice.
  - Quad Flatpack, No-leads (QFN) package configuration.
  - The package thermal pad must be soldered to the board for thermal and mechanical performance.
  - See the additional figure in the Product Data Sheet for details regarding the exposed thermal pad features and dimensions.
  - Falls within JEDEC MO-220.

## IMPORTANT NOTICE

Texas Instruments Incorporated and its subsidiaries (TI) reserve the right to make corrections, enhancements, improvements and other changes to its semiconductor products and services per JESD46, latest issue, and to discontinue any product or service per JESD48, latest issue. Buyers should obtain the latest relevant information before placing orders and should verify that such information is current and complete. All semiconductor products (also referred to herein as "components") are sold subject to TI's terms and conditions of sale supplied at the time of order acknowledgment.

TI warrants performance of its components to the specifications applicable at the time of sale, in accordance with the warranty in TI's terms and conditions of sale of semiconductor products. Testing and other quality control techniques are used to the extent TI deems necessary to support this warranty. Except where mandated by applicable law, testing of all parameters of each component is not necessarily performed.

TI assumes no liability for applications assistance or the design of Buyers' products. Buyers are responsible for their products and applications using TI components. To minimize the risks associated with Buyers' products and applications, Buyers should provide adequate design and operating safeguards.

TI does not warrant or represent that any license, either express or implied, is granted under any patent right, copyright, mask work right, or other intellectual property right relating to any combination, machine, or process in which TI components or services are used. Information published by TI regarding third-party products or services does not constitute a license to use such products or services or a warranty or endorsement thereof. Use of such information may require a license from a third party under the patents or other intellectual property of the third party, or a license from TI under the patents or other intellectual property of TI.

Reproduction of significant portions of TI information in TI data books or data sheets is permissible only if reproduction is without alteration and is accompanied by all associated warranties, conditions, limitations, and notices. TI is not responsible or liable for such altered documentation. Information of third parties may be subject to additional restrictions.

Resale of TI components or services with statements different from or beyond the parameters stated by TI for that component or service voids all express and any implied warranties for the associated TI component or service and is an unfair and deceptive business practice. TI is not responsible or liable for any such statements.

Buyer acknowledges and agrees that it is solely responsible for compliance with all legal, regulatory and safety-related requirements concerning its products, and any use of TI components in its applications, notwithstanding any applications-related information or support that may be provided by TI. Buyer represents and agrees that it has all the necessary expertise to create and implement safeguards which anticipate dangerous consequences of failures, monitor failures and their consequences, lessen the likelihood of failures that might cause harm and take appropriate remedial actions. Buyer will fully indemnify TI and its representatives against any damages arising out of the use of any TI components in safety-critical applications.

In some cases, TI components may be promoted specifically to facilitate safety-related applications. With such components, TI's goal is to help enable customers to design and create their own end-product solutions that meet applicable functional safety standards and requirements. Nonetheless, such components are subject to these terms.

No TI components are authorized for use in FDA Class III (or similar life-critical medical equipment) unless authorized officers of the parties have executed a special agreement specifically governing such use.

Only those TI components which TI has specifically designated as military grade or "enhanced plastic" are designed and intended for use in military/aerospace applications or environments. Buyer acknowledges and agrees that any military or aerospace use of TI components which have **not** been so designated is solely at the Buyer's risk, and that Buyer is solely responsible for compliance with all legal and regulatory requirements in connection with such use.

TI has specifically designated certain components as meeting ISO/TS16949 requirements, mainly for automotive use. In any case of use of non-designated products, TI will not be responsible for any failure to meet ISO/TS16949.

### Products

Audio	<a href="http://www.ti.com/audio">www.ti.com/audio</a>
Amplifiers	<a href="http://amplifier.ti.com">amplifier.ti.com</a>
Data Converters	<a href="http://dataconverter.ti.com">dataconverter.ti.com</a>
DLP® Products	<a href="http://www.dlp.com">www.dlp.com</a>
DSP	<a href="http://dsp.ti.com">dsp.ti.com</a>
Clocks and Timers	<a href="http://www.ti.com/clocks">www.ti.com/clocks</a>
Interface	<a href="http://interface.ti.com">interface.ti.com</a>
Logic	<a href="http://logic.ti.com">logic.ti.com</a>
Power Mgmt	<a href="http://power.ti.com">power.ti.com</a>
Microcontrollers	<a href="http://microcontroller.ti.com">microcontroller.ti.com</a>
RFID	<a href="http://www.ti-rfid.com">www.ti-rfid.com</a>
OMAP Applications Processors	<a href="http://www.ti.com/omap">www.ti.com/omap</a>
Wireless Connectivity	<a href="http://www.ti.com/wirelessconnectivity">www.ti.com/wirelessconnectivity</a>

### Applications

Automotive and Transportation	<a href="http://www.ti.com/automotive">www.ti.com/automotive</a>
Communications and Telecom	<a href="http://www.ti.com/communications">www.ti.com/communications</a>
Computers and Peripherals	<a href="http://www.ti.com/computers">www.ti.com/computers</a>
Consumer Electronics	<a href="http://www.ti.com/consumer-apps">www.ti.com/consumer-apps</a>
Energy and Lighting	<a href="http://www.ti.com/energy">www.ti.com/energy</a>
Industrial	<a href="http://www.ti.com/industrial">www.ti.com/industrial</a>
Medical	<a href="http://www.ti.com/medical">www.ti.com/medical</a>
Security	<a href="http://www.ti.com/security">www.ti.com/security</a>
Space, Avionics and Defense	<a href="http://www.ti.com/space-avionics-defense">www.ti.com/space-avionics-defense</a>
Video and Imaging	<a href="http://www.ti.com/video">www.ti.com/video</a>

### TI E2E Community

[e2e.ti.com](http://e2e.ti.com)

## Looking for pricing, stock, or lifecycle information?

Click below to explore more details on WIN SOURCE:

 [View TPS65562RGTR](#) on WIN SOURCE

 [Texas Instruments](#) Information

## Optimize Your Supply Chain with WIN SOURCE Solutions

-  Global Sourcing Solution
-  Obsolete Management
-  Cost Control Management
-  Shortage Management
-  Alternative Solution
-  Excess Inventory Management