



# THE DATASHEET OF RT8471GFP



# 1.2A/1A, Hysteretic, High Brightness LED Driver with Internal Switch

## General Description

The RT8471 is a high efficiency, continuous mode inductive step-down converter, designed for driving single or multiple series connected LEDs from a voltage source higher than the LED voltage. It operates from an input voltage of 7V to 36V and employs hysteretic control with a high side current sense resistor to set the constant output current.

The RT8471 includes an output switch and a high side output current sensing circuit, which uses an external resistor to set the nominal average output current. LED brightness control is achieved with PWM dimming from an analog or PWM input signal.

The RT8471 is available in a small TSOT-23-5 package or a more thermal efficient SOP-8 (Exposed Pad) package.

## Ordering Information

- RT8471□□
- Package Type
    - J5 : TSOT-23-5
    - SP : SOP-8 (Exposed Pad-Option 1)
  - Lead Plating System
    - G : Green (Halogen Free and Pb Free) (for TSOT-23-5 Only)
    - Z : ECO (Ecological Element with Halogen Free and Pb free) (for SOP-8 (Exposed Pad) Only)

Note :

Richtek products are :

- ▶ RoHS compliant and compatible with the current requirements of IPC/JEDEC J-STD-020.
- ▶ Suitable for use in SnPb or Pb-free soldering processes.

## Marking Information

RT8471GJ5

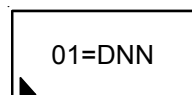

01= : Product Code  
DNN : Date Code

RT8471ZSP

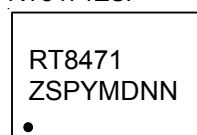

RT8471ZSP : Product Number  
YMDNN : Date Code

## Features

- 7V to 36V Input Voltage Range
- Hysteretic Control with High Side Current Sensing
- Internal N-MOSFET with 350mΩ Low R<sub>DS(ON)</sub>
- 1A Output Current (For TSOT-23-5 Only)
- 1.2A Output Current (For SOP-8 (Exposed Pad) Only)
- Up to 97% Efficiency
- Typical ±5% LED Current Accuracy
- Analog or PWM Control Signal for LED Dimming
- 300Hz On-Board Ramp Generator
- Input Under Voltage Lockout
- Thermal Shutdown Protection
- RoHS Compliant and Halogen Free

## Applications

- Automotive LED Lighting
- High Power LED Lighting
- Indicator and Emergency Lighting
- Architectural Lighting
- Low Voltage Industrial Lighting
- Signage and Decorative LED Lighting

## Pin Configurations

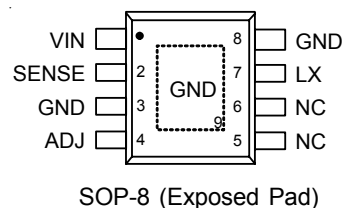
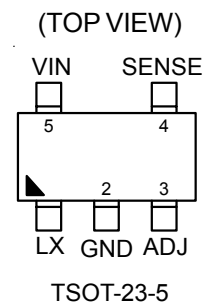

## Typical Application Circuit

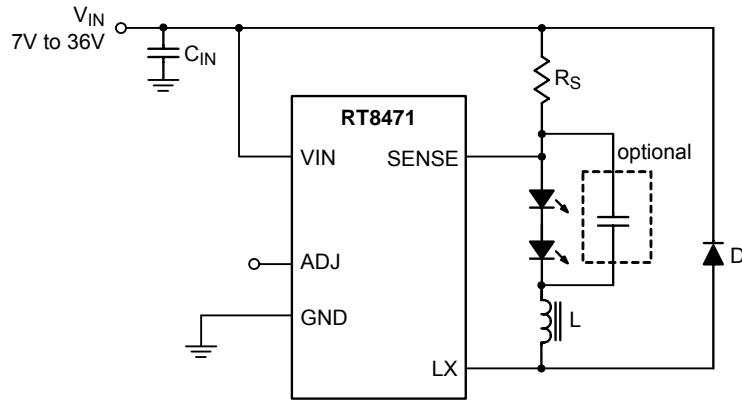

## Functional Pin Description

Pin No.		Pin Name	Pin Function
TSOT-23-5	SOP-8 (Exposed Pad)		
1	7	LX	Switch Output Terminal. Drain of internal N-MOSFET.
2	3, 8, 9 (Exposed Pad)	GND	Ground. The exposed pad must be soldered to a large PCB and connected to GND for maximum power dissipation.
3	4	ADJ	Dimming Control Input : --- Analog signal input for analog PWM dimming. --- PWM signal input for digital PWM dimming.
4	2	SENSE	Output Current Sense. Sense LED string current with an external resistor connected between VIN and SENSE.
5	1	VIN	Supply Input Voltage.
-	5, 6	NC	No Internal Connection.

## Function Block Diagram

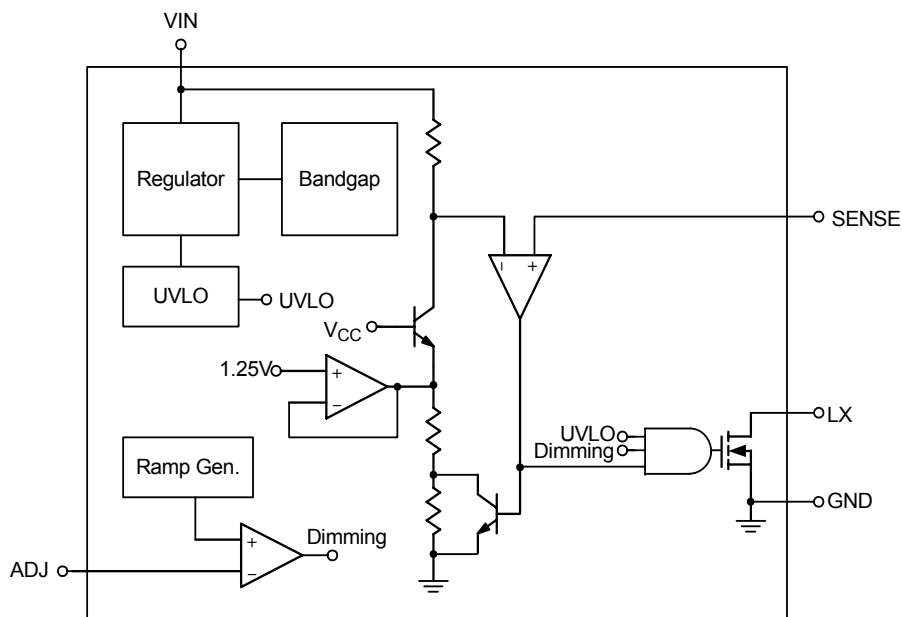

**Absolute Maximum Ratings** (Note 1)

- Supply Input Voltage,  $V_{IN}$  ----- -0.3V to 40V
- Switch Voltage, LX ----- -0.3V to ( $V_{IN} + 0.7V$ )
- Sense Voltage, SENSE ----- ( $V_{IN} - 5V$ ) to ( $V_{IN} + 0.3V$ )
- All Other Pins ----- -0.3V to 6V
- Power Dissipation,  $P_D @ T_A = 25^\circ C$ 
  - TSOT-23-5 (Single-layer PCB) ----- 0.400W
  - TSOT-23-5 (Four-layer PCB) ----- 0.625W
  - SOP-8 (Exposed pad) ----- 1.333W
- Package Thermal Resistance (Note 2)
  - TSOT-23-5,  $\theta_{JA}$  (Single-layer PCB) ----- 250°C/W
  - TSOT-23-5,  $\theta_{JA}$  (Four-layer PCB) ----- 160°C/W
  - TSOT-23-5,  $\theta_{JC}$  (Single-layer PCB) ----- 130°C/W
  - SOP-8 (Exposed pad),  $\theta_{JA}$  ----- 75°C/W
  - SOP-8 (Exposed pad),  $\theta_{JC}$  ----- 15°C/W
- Junction Temperature ----- 150°C
- Lead Temperature (Soldering, 10 sec.) ----- 260°C
- Storage Temperature Range ----- -65°C to 150°C
- ESD Susceptibility (Note 3)
  - HBM (Human Body Mode) ----- 2kV
  - MM (Machine Mode) ----- 200V

**Recommended Operating Conditions** (Note 4)

- Supply Input Voltage,  $V_{IN}$  ----- 7V to 36V
- Junction Temperature Range ----- -40°C to 125°C

**Electrical Characteristics**

( $V_{IN} = 12V, T_A = 25^\circ C$ , unless otherwise specified)

Parameter	Symbol	Test Conditions	Min	Typ	Max	Unit
Mean Current Sense Threshold Voltage	$V_{SENSE}$	Measure on SENSE Pin with Respecting to $V_{IN}$ . ADJ is Floating.	95	100	105	mV
Sense Threshold Hysteresis	$\Delta V_{SENSE}$		--	±15	--	%
Low Side Switch On-Resistance	$R_{DS(ON)}$		--	350	500	mΩ
Low Side Switch Leakage Current		$V_{LX} = 12V, V_{ADJ} = 0V$	--	0.01	10	μA
Under Voltage Lockout Threshold	$V_{UVLO}$	$V_{IN}$ Rising	--	5.2	--	V
Under Voltage Lockout Threshold Hysteresis	$\Delta V_{UVLO}$		--	400	--	mV
Ramp Frequency	$f_{RAMP}$		--	300	--	Hz
ADJ Input Threshold Voltage	Logic-High	$V_{ADJ, H}$	1.4	--	--	V
	Logic-Low	$V_{ADJ, L}$	--	--	0.2	
Analog Dimming Range			0.3	--	1.3	V
Analog Dimming Threshold Voltage	Logic-High		--	1.2	1.3	V
	Logic-Low		0.3	0.4	--	

*To be continued*

Parameter	Symbol	Test Conditions	Min	Typ	Max	Unit
Minimum Switch On-Time	$t_{ON(MIN)}$	LX Switch On	--	210	--	ns
Minimum Switch Off-Time	$t_{OFF(MIN)}$	LX Switch Off	--	170	--	ns
Quiescent Input Current with Output Off	$I_{VIN, Off}$	$V_{ADJ} = 0V$	--	450	--	$\mu A$
Quiescent Input Current with Output Switching	$I_{VIN, On}$	ADJ is Floating, $f_{SW} = 250kHz$ , $V_{IN} = 8V$	--	1000	--	$\mu A$
Internal Propagation Delay	$t_{PD}$		--	25	--	ns
Sense Pin Input Current	$I_{SENSE}$	$V_{SENSE} = V_{IN} - 0.1V$	--	300	--	nA
Thermal Shutdown	$T_{SD}$		--	150	--	$^{\circ}C$
Thermal Shutdown Hysteresis	$\Delta T_{SD}$		--	30	--	$^{\circ}C$

**Note 1.** Stresses listed as the above "Absolute Maximum Ratings" may cause permanent damage to the device. These are for stress ratings. Functional operation of the device at these or any other conditions beyond those indicated in the operational sections of the specifications is not implied. Exposure to absolute maximum rating conditions for extended periods may remain possibility to affect device reliability.

**Note 2.**  $\theta_{JA}$  is measured in natural convection at  $T_A = 25^{\circ}C$  on a single-layer and four-layer test board of JEDEC 51 thermal measurement standard. For SOP-8 (Exposed Pad) the measurement case position of  $\theta_{JC}$  is on the exposed pad of the package. For TSOT-23-5, the measurement case position of  $\theta_{JC}$  is on the lead of the package.

**Note 3.** Devices are ESD sensitive. Handling precaution is recommended.

**Note 4.** The device is not guaranteed to function outside its operating conditions.

**Typical Operating Characteristics**

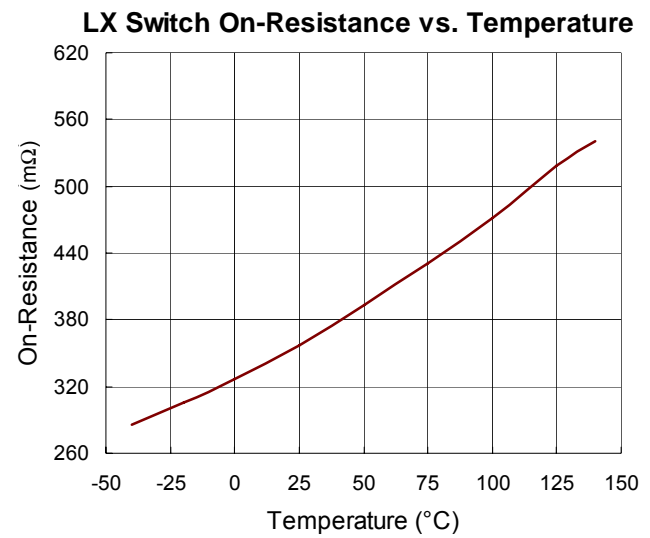
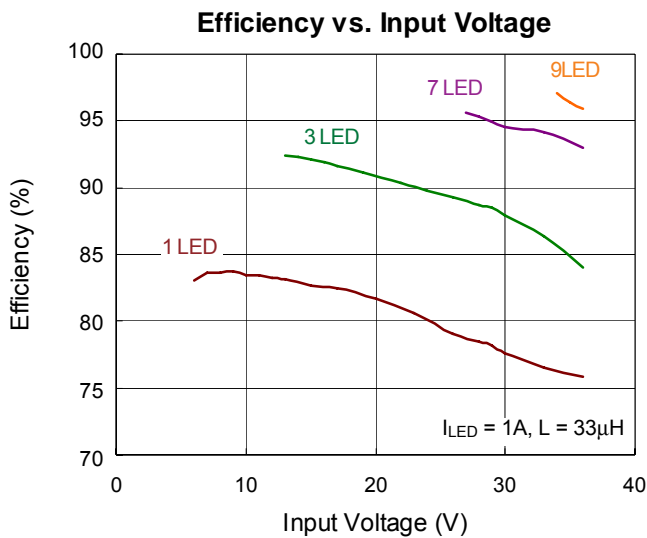
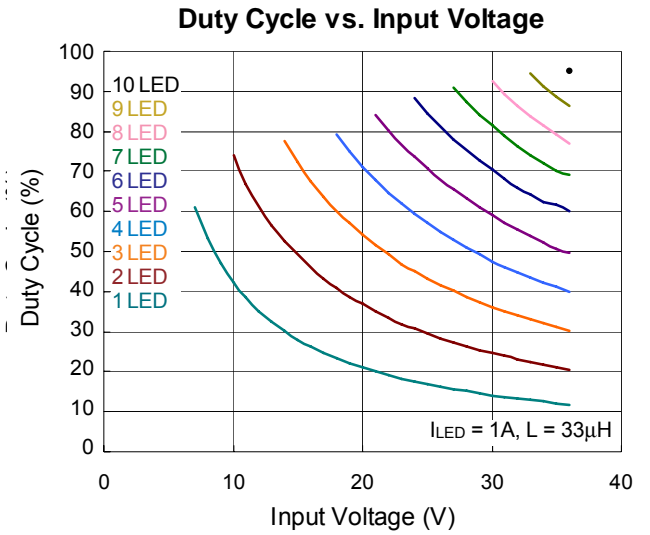
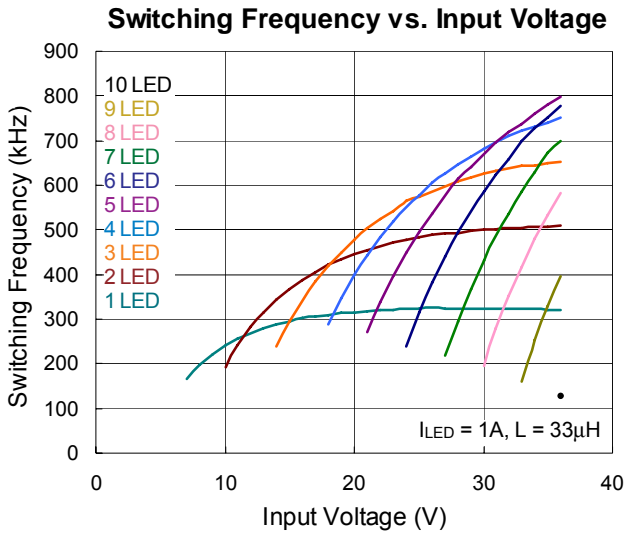
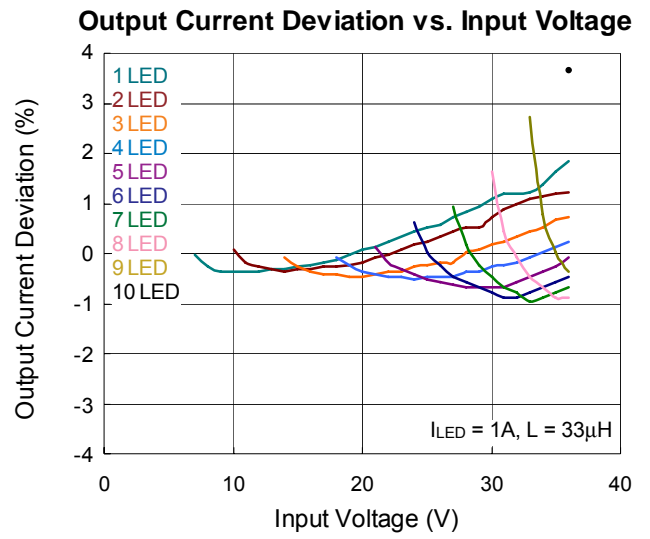
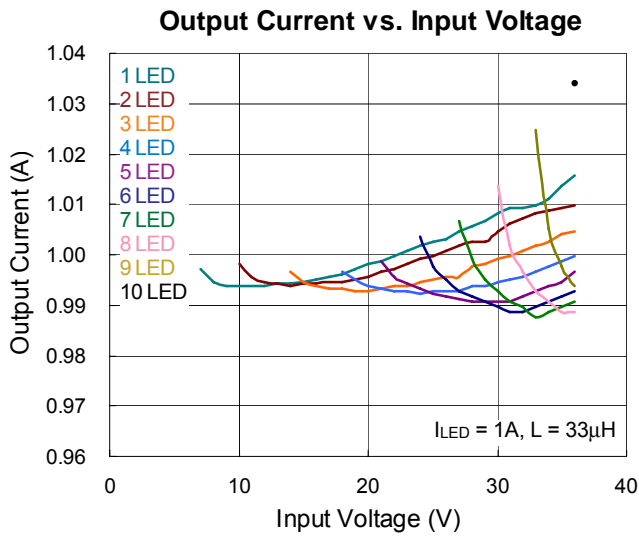

Quiescent Input Current vs. Input Voltage

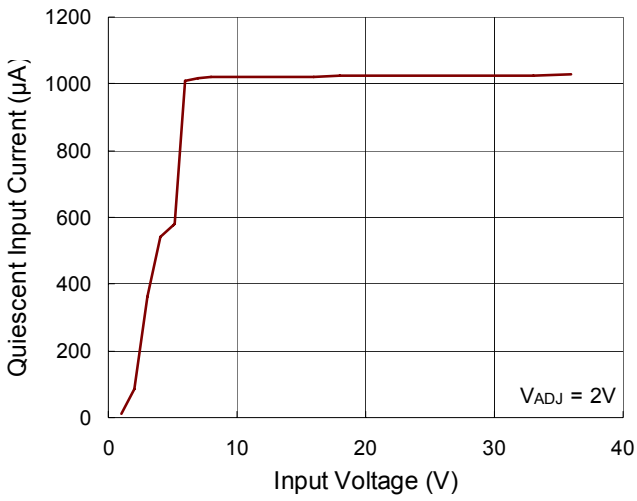

Quiescent Input Current vs. Input Voltage

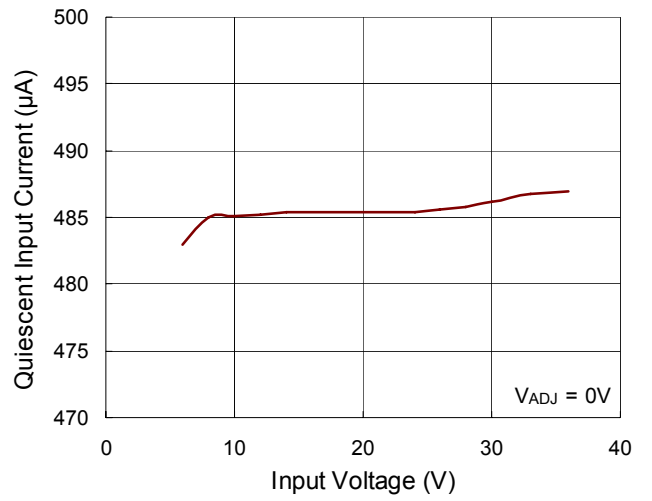

Output Current vs. PWM Duty Cycle

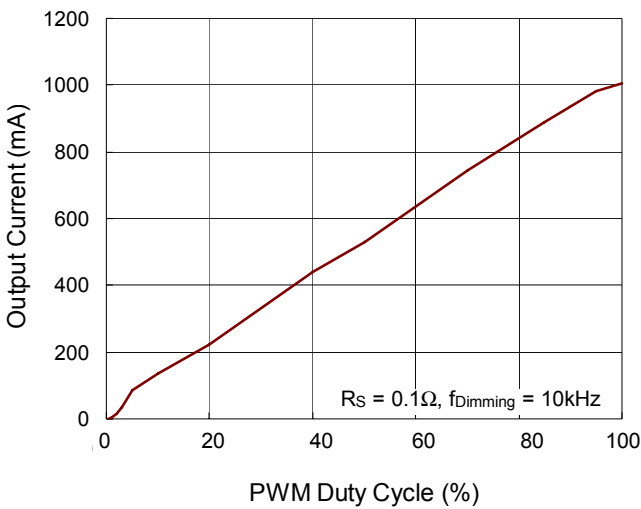

Output Current vs. PWM Duty Cycle

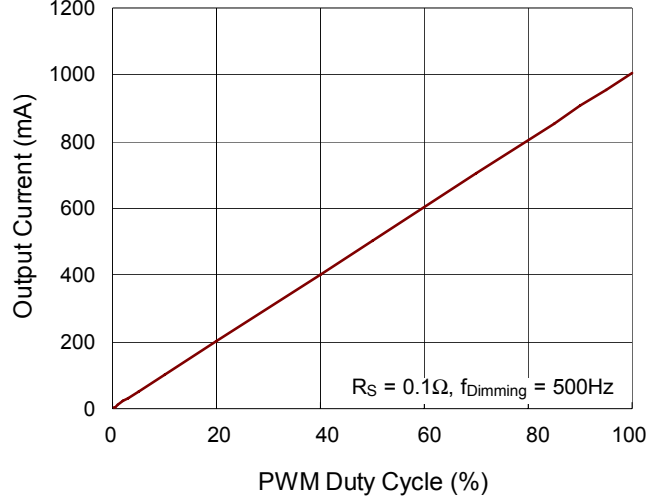

Output Current vs. ADJ Voltage

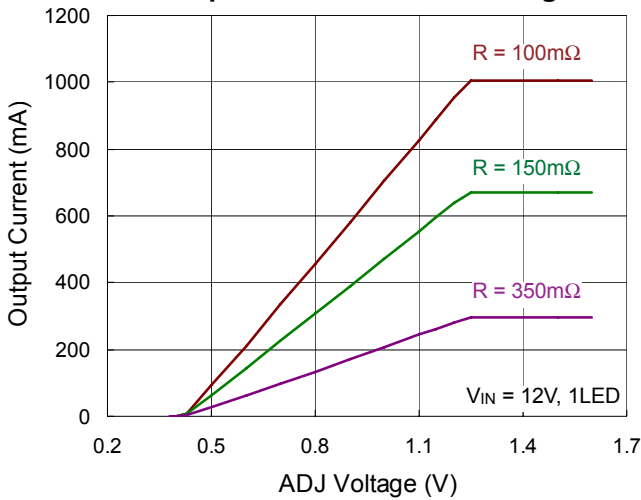

Ramp Frequency vs. Temperature

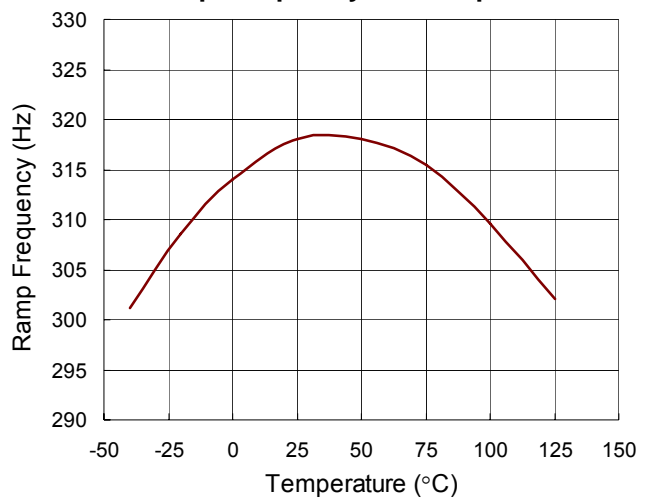

Digital Dimming from ADJ On

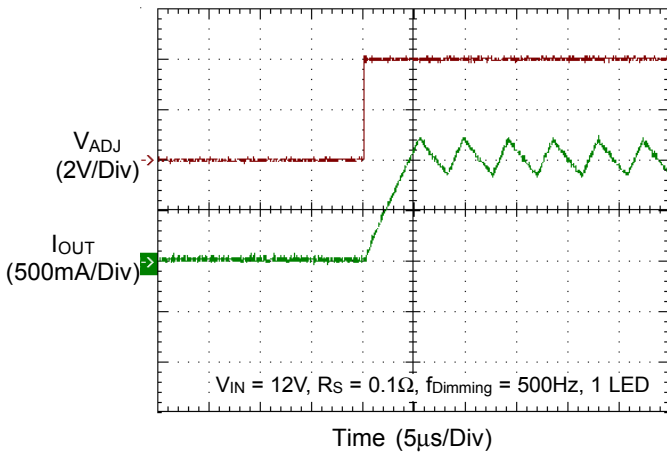

Digital Dimming from ADJ Off

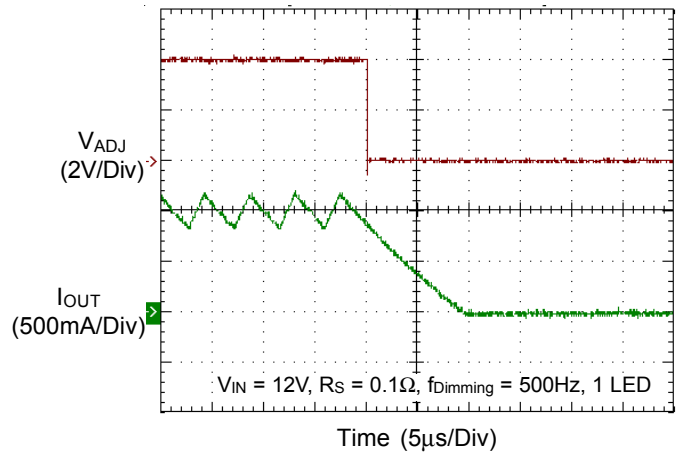

Power On from VIN

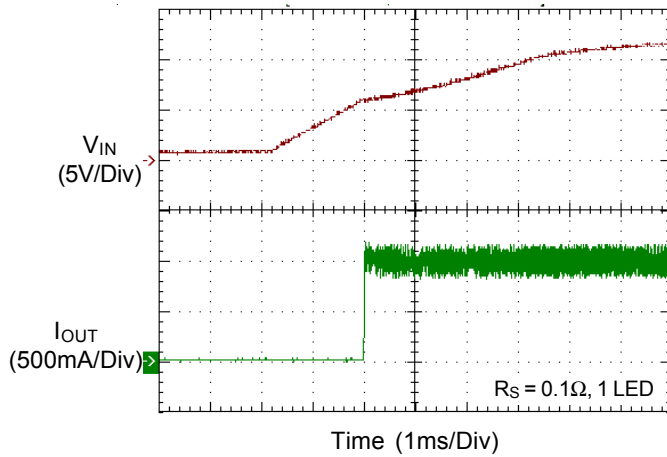

Power Off from VIN

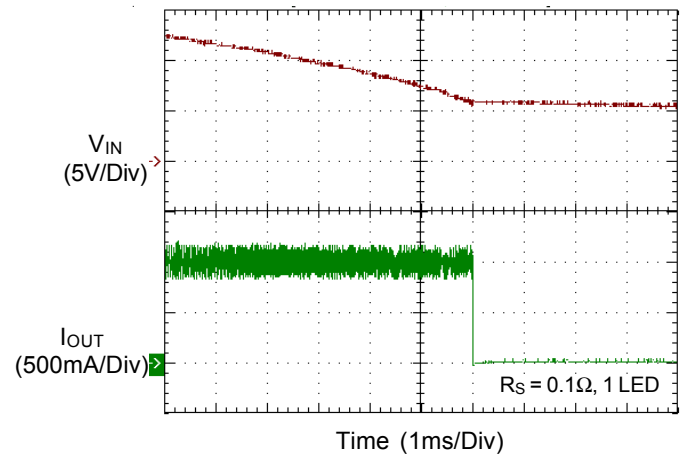

## Application Information

The RT8471 is a simple high efficiency, continuous mode inductive step-down converter. The device operates with an input voltage range from 7V to 36V and delivers up to 1.2A of output current. A high side current sense resistor sets the output current. A dedicated PWM dimming input enables pulsed LED dimming over a wide range of brightness levels. A high side current sensing scheme and an onboard current setting circuitry minimize the number of external components. A 1% sense resistor performs a  $\pm 5\%$  LED current accuracy for the best performance.

### Under Voltage Lockout (UVLO)

The RT8471 includes a UVLO feature with 400mV hysteresis. The internal MOSFET turns off when  $V_{IN}$  falls below 4.8V (typ.).

### Setting Average Output Current

The RT8471 output current which flows through the LEDs is set by an external resistor ( $R_S$ ) connected between the VIN and SENSE terminal. The relationship between output current ( $I_{OUT}$ ) and  $R_S$  is shown as below :

$$I_{OUTavg} = \frac{0.1V}{R_S} \quad (A)$$

### Analog Dimming Control

The ADJ terminal can be driven by an external voltage ( $V_{ADJ}$ ) to adjust the average output current. The average output current is given by :

$$I_{OUTavg} = \left( \frac{0.1V}{R_S} \right) \times \frac{V_{ADJ} - 0.4}{0.8}$$

where  $V_{ADJ}$  is ranged from 0.4V to 1.2V. When  $V_{ADJ}$  is larger than 1.2V, the output current value will only depend on the external resistor ( $R_S$ ).

### Digital Dimming Control

A Pulse Width Modulated (PWM) signal can drive the ADJ terminal directly. Notice that the PWM signal logic high level must be above 1.4V and the logic low level must be below 0.2V at the ADJ terminal. It's recommended to maintain the PWM dimming at low frequency (ex. 500Hz ) in order to obtain a linear dimming curve.

### PWM Soft-Start Behavior

The RT8471 features an optional PWM soft-start behavior that allows for gradual brightness transition. This is achieved by simply connecting an external capacitor between the ADJ pin and GND. An internal current source will then charge this capacitor for soft-start behavior, resulting in steady LED current increase and decrease during power on and power off, as shown in Figure 1.

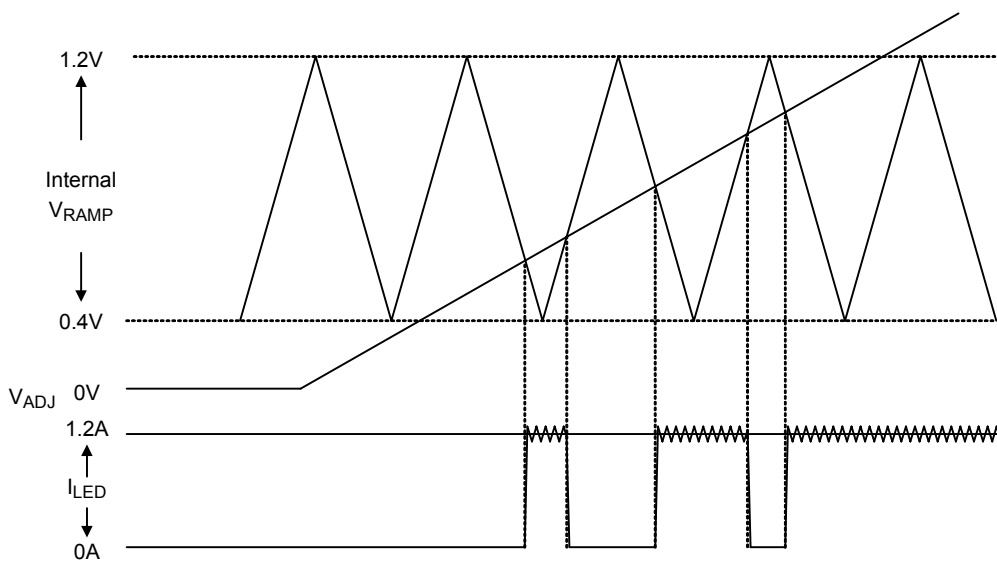

Figure 1. PWM Soft-Start Behavior Mechanism

The capacitor can be selected according to below equation :

$$C = 1.5 \times 10^{-6} \times t_{SS}$$

where  $t_{SS}$  is the soft-start period.

**LED Current Ripple Reduction**

Higher LED current ripple will shorten the LED life time and increase heat accumulation of LED. There are two ways to reduce the LED current ripple. One way is by increasing the inductance to lower LED current ripple in absence of an output capacitor. The other way is by adding an output capacitor in parallel with the LED. This will then allow the use of a smaller inductor.

**Inductor Selection**

The inductance is determined by inductor current ripple, switching frequency, duty ratio, circuit specifications and component parameters, as expressed in the following equation :

$$L > \left[ V_{IN} - V_{OUT} - V_{SEN} - (R_{DS(ON)} \times I_{OUT}) \right] \times \frac{D}{f_{SW} \times \Delta I_L}$$

where

$f_{SW}$  is the switching frequency (Hz)

$R_{DS(ON)}$  is the low side switch on-resistance of internal MOSFET ( = 0.35Ω typical)

D is the duty cycle determined by  $V_{OUT}/V_{IN}$

$I_{OUT}$  is the required LED current (A)

$\Delta I_L$  is the inductor peak-peak ripple current (internally set to  $0.3 \times I_{OUT}$ )

$V_{IN}$  is the input supply voltage (V)

$V_{OUT}$  is the total LED forward voltage (V)

Besides, the selected inductance has also to satisfy the limit of the minimum switch on/off time. The calculated on time must be greater than 210ns of the minimum on time, and the off time must be greater than 170ns of the minimum off time. The following equation can be used to verify the suitability of the inductor value.

$$t_{ON} = \frac{L \times \Delta I_L}{V_{IN} - V_{OUT} - I_{OUT} (R_{SEN} + R_L + R_{DS(ON)})}$$

$> t_{ON(MIN)}(210ns \text{ typ.})$

$$t_{OFF} = \frac{L \times \Delta I_L}{V_{OUT} + V_D + V_{SEN} + (I_{OUT} \times R_L)}$$

$> t_{OFF(MIN)}(170ns \text{ typ.})$

where

$V_D$  is the rectifier diode forward voltage (V)

$V_{SEN}$  is the voltage cross current sense resistor (V)

$R_L$  is the inductor DC resistance (Ω)

L is the inductance (H)

The saturation current of the selected inductor must be higher than the peak output LED current, and the continuous current rating must be above the average output LED current. In general, the inductor saturation current should be 1.5 times the LED current. In order to reduce the output current ripple, a higher inductance is recommended at higher supply voltages. However, it could also cause a higher line resistance and result in a lower efficiency.

**Diode selection**

To obtain better efficiency, the Schottky diode is recommended for its low reverse leakage current, low recovery time and low forward voltage. With its low power dissipation, the Schottky diode outperforms other silicon diodes and increase overall efficiency.

**Input Capacitor selection**

Input capacitor has to supply peak current to the inductor and flatten the current ripple on the input. The low ESR condition is required to avoid increasing power loss. The ceramic capacitor is recommended due to its excellent high frequency characteristic and low ESR, which are suitable for the RT8471. For maximum stability over the entire operating temperature range, capacitors with better dielectric are suggested.

**Thermal Protection**

A thermal protection feature is included to protect the RT8471 from excessive heat damage. When the junction temperature exceeds a threshold of 150°C, the thermal protection will turn off the LX terminal. When the junction temperature drops below 120°C, the RT8471 will turn back on the LX terminal and return to normal operations.

## Thermal Considerations

For continuous operation, do not exceed absolute maximum junction temperature. The maximum power dissipation depends on the thermal resistance of the IC package, PCB layout, rate of surrounding airflow, and difference between junction and ambient temperature. The maximum power dissipation can be calculated by the following formula :

$$P_{D(MAX)} = (T_{J(MAX)} - T_A) / \theta_{JA}$$

where  $T_{J(MAX)}$  is the maximum junction temperature,  $T_A$  is the ambient temperature, and  $\theta_{JA}$  is the junction to ambient thermal resistance.

For recommended operating condition specifications of the RT8471, the maximum junction temperature is 125°C and  $T_A$  is the ambient temperature. The junction to ambient thermal resistance,  $\theta_{JA}$ , is layout dependent. For TSOT-23-5 packages, the thermal resistance,  $\theta_{JA}$ , is 250°C/W on a standard JEDEC 51-3 single-layer thermal test board and 160°C/W on a standard JEDEC 51-7 four-layer thermal test board. For SOP-8 (Exposed pad) package, the thermal resistance,  $\theta_{JA}$ , is 75°C/W on a standard JEDEC 51-7 four-layer thermal test board. The maximum power dissipation at  $T_A = 25^\circ\text{C}$  can be calculated by the following formulas :

$$P_{D(MAX)} = (125^\circ\text{C} - 25^\circ\text{C}) / (250^\circ\text{C/W}) = 0.4\text{W for TSOT-23-5 package (single-layer PCB)}$$

$$P_{D(MAX)} = (125^\circ\text{C} - 25^\circ\text{C}) / (160^\circ\text{C/W}) = 0.625\text{W for TSOT-23-5 package (four-layer PCB)}$$

$$P_{D(MAX)} = (125^\circ\text{C} - 25^\circ\text{C}) / (75^\circ\text{C/W}) = 1.333\text{W for SOP-8 (Exposed pad) package}$$

The maximum power dissipation depends on the operating ambient temperature for fixed  $T_{J(MAX)}$  and thermal resistance,  $\theta_{JA}$ . For the RT8471 packages, the derating curves in Figure 2 allow the designer to see the effect of rising ambient temperature on the maximum power dissipation.

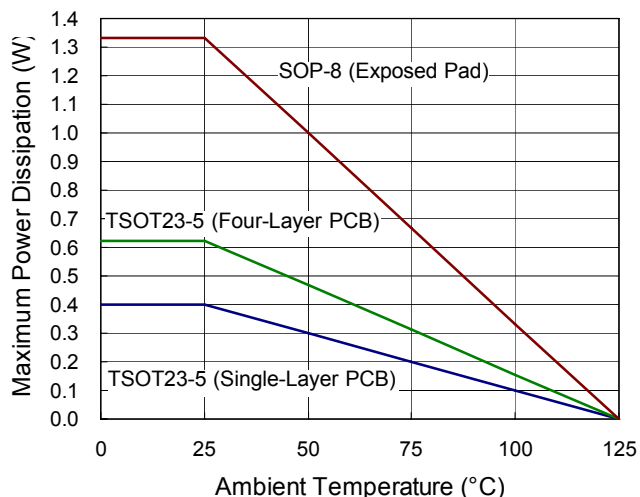

Figure 2. Derating Curve for Packages

## Layout Considerations

For best performance of the RT8471, please abide the following layout guide.

- ▶ The capacitor  $C_{IN}$ ,  $C_{ADJ}$  and external resistor,  $R_S$ , must be placed as close as possible to the VIN and SENSE pins of the device respectively.
- ▶ The GND should be connected to a strong ground plane.
- ▶ Keep the main current traces as short and wide as possible.
- ▶ The inductor (L) should be mounted as close to the device with low resistance connections.
- ▶ The ADJ pin trace need to be kept far away from LX terminal.

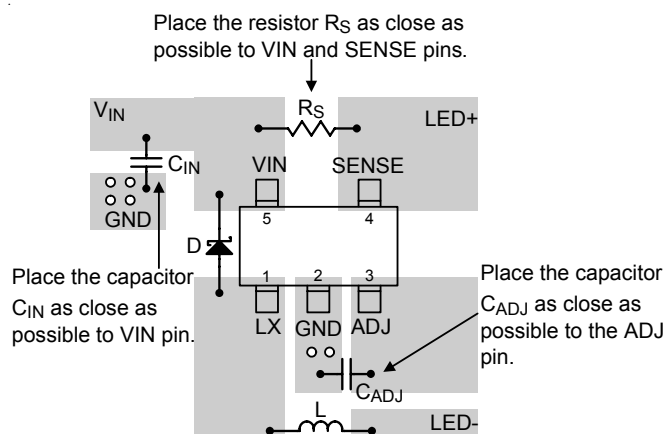
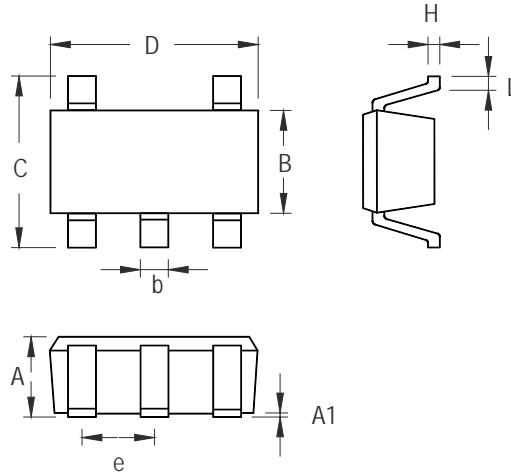

Figure 3. PCB Layout Guide

**Outline Dimension**



Symbol	Dimensions In Millimeters		Dimensions In Inches	
	Min	Max	Min	Max
A	0.700	1.000	0.028	0.039
A1	0.000	0.100	0.000	0.004
B	1.397	1.803	0.055	0.071
b	0.300	0.559	0.012	0.022
C	2.591	3.000	0.102	0.118
D	2.692	3.099	0.106	0.122
e	0.838	1.041	0.033	0.041
H	0.080	0.254	0.003	0.010
L	0.300	0.610	0.012	0.024

**TSOT-23-5 Surface Mount Package**

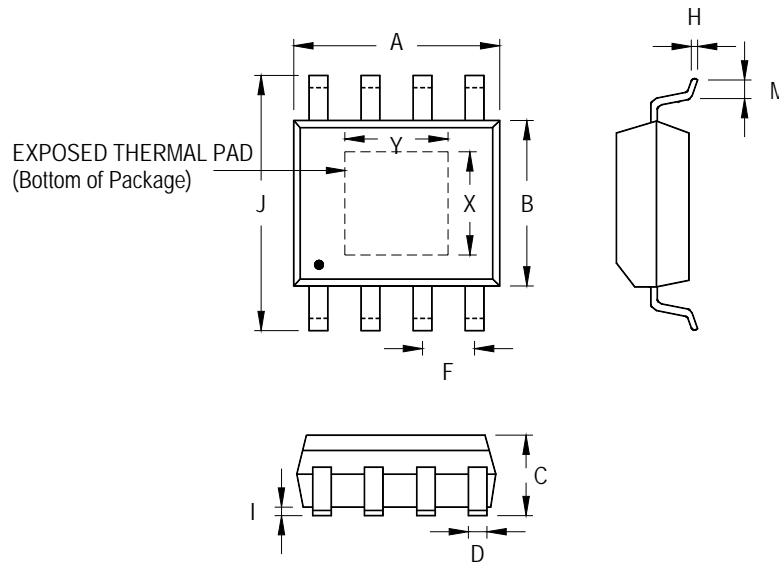

Symbol	Dimensions In Millimeters		Dimensions In Inches		
	Min	Max	Min	Max	
A	4.801	5.004	0.189	0.197	
B	3.810	4.000	0.150	0.157	
C	1.346	1.753	0.053	0.069	
D	0.330	0.510	0.013	0.020	
F	1.194	1.346	0.047	0.053	
H	0.170	0.254	0.007	0.010	
I	0.000	0.152	0.000	0.006	
J	5.791	6.200	0.228	0.244	
M	0.406	1.270	0.016	0.050	
Option 1	X	2.000	2.300	0.079	0.091
	Y	2.000	2.300	0.079	0.091
Option 2	X	2.100	2.500	0.083	0.098
	Y	3.000	3.500	0.118	0.138

**8-Lead SOP (Exposed Pad) Plastic Package**

**Richtek Technology Corporation**

Headquarter  
 5F, No. 20, Taiyuen Street, Chupei City  
 Hsinchu, Taiwan, R.O.C.  
 Tel: (8863)5526789 Fax: (8863)5526611



**Richtek Technology Corporation**

Taipei Office (Marketing)  
 5F, No. 95, Minchiuan Road, Hsintien City  
 Taipei County, Taiwan, R.O.C.  
 Tel: (8862)86672399 Fax: (8862)86672377  
 Email: marketing@richtek.com

Information that is provided by Richtek Technology Corporation is believed to be accurate and reliable. Richtek reserves the right to make any change in circuit design, specification or other related things if necessary without notice at any time. No third party intellectual property infringement of the applications should be guaranteed by users when integrating Richtek products into any application. No legal responsibility for any said applications is assumed by Richtek.

## Looking for pricing, stock, or lifecycle information?

Click below to explore more details on WIN SOURCE:

-  [View RT8471GFP on WIN SOURCE](#)
-  [Richtek USA Inc. Information](#)

## Optimize Your Supply Chain with WIN SOURCE Solutions

-  Global Sourcing Solution
-  Obsolete Management
-  Cost Control Management
-  Shortage Management
-  Alternative Solution
-  Excess Inventory Management