



**THE DATASHEET OF  
DS92LV3242TVS/NOPB**



## DS92LV3241/DS92LV3242 20-85 MHz 32-Bit Channel Link II Serializer / Deserializer

Check for Samples: [DS92LV3241](#), [DS92LV3242](#)

### FEATURES

- **Wide Operating Range Embedded Clock SER/DES**
  - Up to 32-bit Parallel LVCMOS Data
  - 20 to 85 MHz Parallel Clock
  - Up to 2.72 Gbps Application Data Payload
- **Selectable Serial LVDS Bus Width**
  - Dual Lane Mode (20 to 50 MHz)
  - Quad Lane Mode (40 to 85 MHz)
- **Simplified Clocking Architecture**
  - No Separate Serial Clock Line
  - No reference Clock Required
  - Receiver Locks to Random Data
- **On-Chip Signal Conditioning for Robust Serial Connectivity**
  - Transmit Pre-Emphasis
  - Data Randomization
  - DC-Balance Encoding
  - Receive Channel Deskew
  - Supports up to 10m CAT-5 at 2.7 Gbps
- **Integrated LVDS Terminations**
- **Built-in AT-SPEED BIST for End-to-End System Testing**
- **AC-Coupled Interconnect for Isolation and Fault Protection**
- **> 4KV HBM ESD Protection**
- **Space-Saving 64-pin TQFP Package**
- **Full Industrial Temperature Range : -40° to +85°C**

### APPLICATIONS

- **Industrial Imaging (Machine-Vision) and Control**
- **Security & Surveillance Cameras and Infrastructure**
- **Medical imaging**
- **Up to 30 bits per Pixel, VGA to HD Video Transport and Display**

### DESCRIPTION

The DS92LV3241 (SER) serializes a 32-bit data bus into 2 or 4 (selectable) embedded clock LVDS serial channels for a data payload rate up to 2.72 Gbps over cables such as CATx, or backplanes FR-4 traces. The companion DS92LV3242 (DES) deserializes the 2 or 4 LVDS serial data channels, de-skews channel-to-channel delay variations and converts the LVDS data stream back into a 32-bit LVCMOS parallel data bus.

On-chip data Randomization/Scrambling and DC balance encoding and selectable serializer Pre-emphasis ensure a robust, low-EMI transmission over longer, lossy cables and backplanes. The Deserializer automatically locks to incoming data without an external reference clock or special sync patterns, providing an easy “plug-and-lock” operation.

By embedding the clock in the data payload and including signal conditioning functions, the Channel-Link II SerDes devices reduce trace count, eliminate skew issues, simplify design effort and lower cable/connector cost for a wide variety of video, control and imaging applications. A built-in AT-SPEED BIST feature validates link integrity and may be used for system diagnostics.



Please be aware that an important notice concerning availability, standard warranty, and use in critical applications of Texas Instruments semiconductor products and disclaimers thereto appears at the end of this data sheet.

All trademarks are the property of their respective owners.

Block Diagram

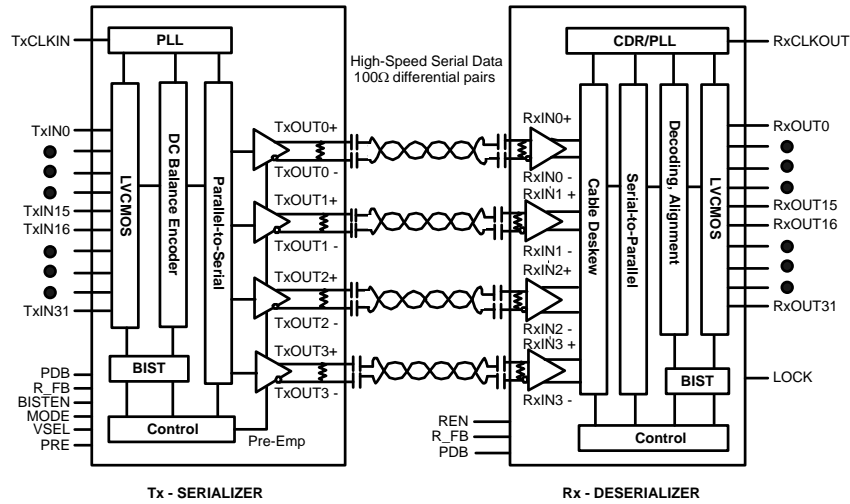

Mode Diagrams

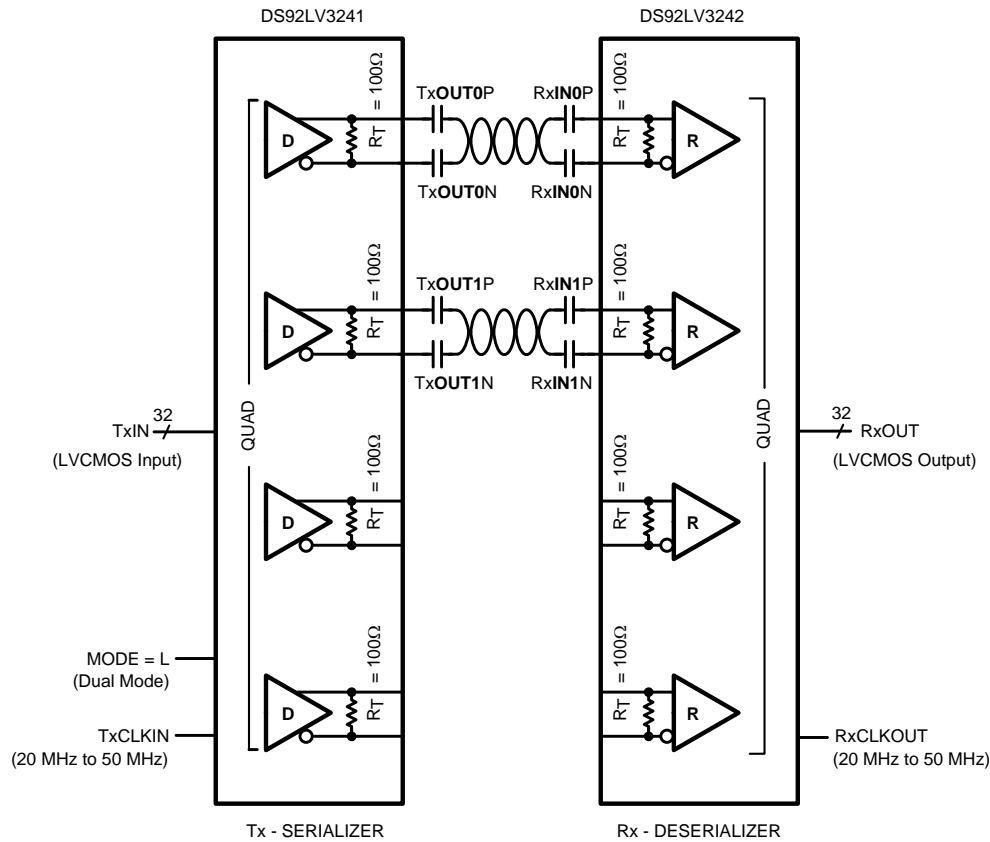

Figure 1. 'Dual Mode

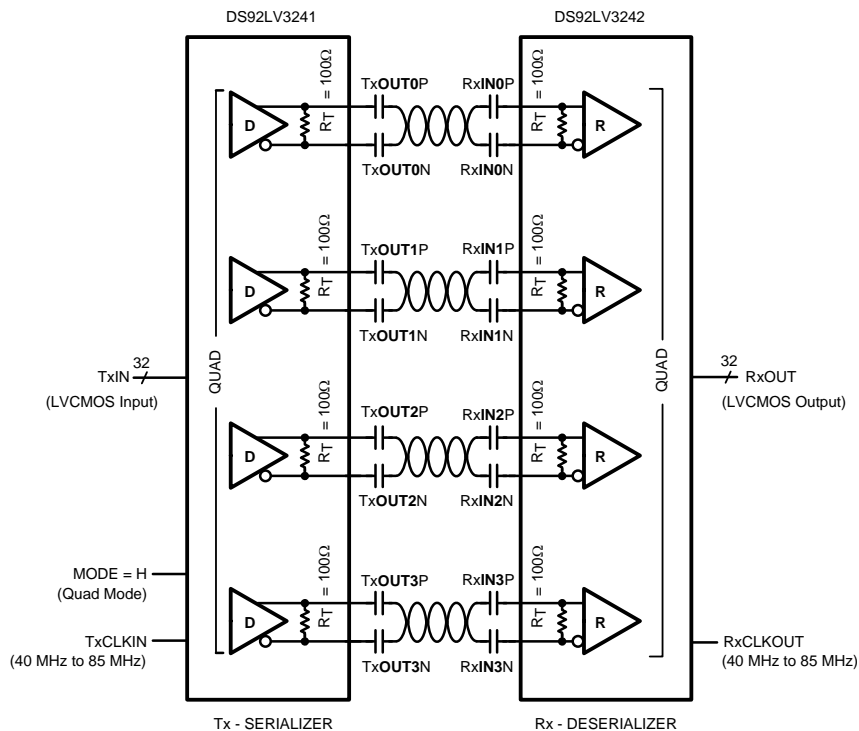

Figure 2. Quad Mode

DS92LV3241 Pin Diagram

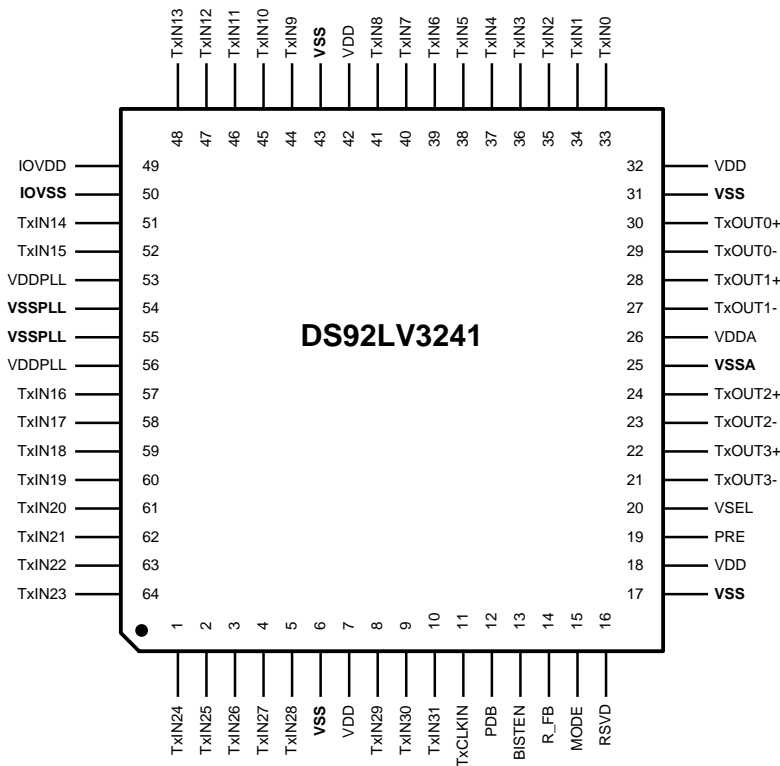

Figure 3. DS92LV3241 Pin Diagram- Top View 64-Pin TQFP (PAG Package)

**DS92LV3241 Serializer PIN DESCRIPTIONS**

Pin #	Pin Name	I/O, Type	Description
<b>LVCMOS PARALLEL INTERFACE PINS</b>			
10–8, 5–1, 64–57, 52–51, 48–44, 41–33	TxIN[31:29], TxIN[28:24], TxIN[23:16], TxIN[15:14], TxIN[13:9], TxIN[8:0]	I, LVCMOS	Serializer Parallel Interface Data Input Pins.
11	TxCLKIN	I, LVCMOS	Serializer Parallel Interface Clock Input Pin. Strobe edge set by R_FB configuration pin.
<b>CONTROL AND CONFIGURATION PINS</b>			
12	PDB	I, LVCMOS	Serializer Power Down Bar (ACTIVE LOW) PDB = L; Device Disabled, Differential serial outputs are put into TRI-STATE stand-by mode, PLL is shutdown PDB = H; Device Enabled
15	MODE	I, LVCMOS	Dual or Quad mode select (ACTIVE H) MODE = L (default); Dual Mode, MODE = H; Quad Mode
19	PRE	I, LVCMOS	PRE-emphasis level select pin PRE = (RPRE > 12kΩ); I <sub>max</sub> = [(1.2/R) x 20 x 2], R <sub>min</sub> = 12kΩ. PRE = H or floating; pre-emphasis is disabled.
14	R_FB	I, LVCMOS	Rising/Falling Bar Clock Edge Select R_FB = H; Rising Edge, R_FB = L; Falling Edge
20	VSEL	I, LVCMOS	VOD (Differential Output Voltage) Level Select VSEL = L; Low Swing, VSEL = H; High Swing
13	BISTEN	I, LVCMOS	BIST Enable BISTEN = L; BIST OFF, (default), normal operating mode. BISTEN = H; BIST Enabled (ACTIVE HIGH)
16	RSVD	I, LVCMOS	Reserved — MUST BE TIED LOW
<b>LVDS SERIAL INTERFACE PINS</b>			
22, 24, 28, 30	TxOUT[3:0]+	O, LVDS	Serializer LVDS Non-Inverted Outputs(+)
21, 23, 27, 29	TxOUT[3:0]-	O, LVDS	Serializer LVDS Inverted Outputs(-)
<b>POWER / GROUND PINS</b>			
7, 18, 32, 42	VDD	VDD	Digital Voltage supply, 3.3V
6, 17, 31, 43	VSS	GND	Digital ground
53, 56	VDDPLL	VDD	Analog Voltage supply, PLL POWER, 3.3V
54, 55	VSSPLL	GND	Analog ground, PLL GROUND
26	VDDA	VDD	Analog Voltage supply
25	VSSA	GND	Analog ground
49	IOVDD	VDD	Digital IO Voltage supply Connect to 1.8V typ for 1.8V LVCMOS interface Connect to 3.3V typ for 3.3V LVCMOS interface
50	IOVSS	GND	Digital IO ground

DS92LV3242 Pin Diagram

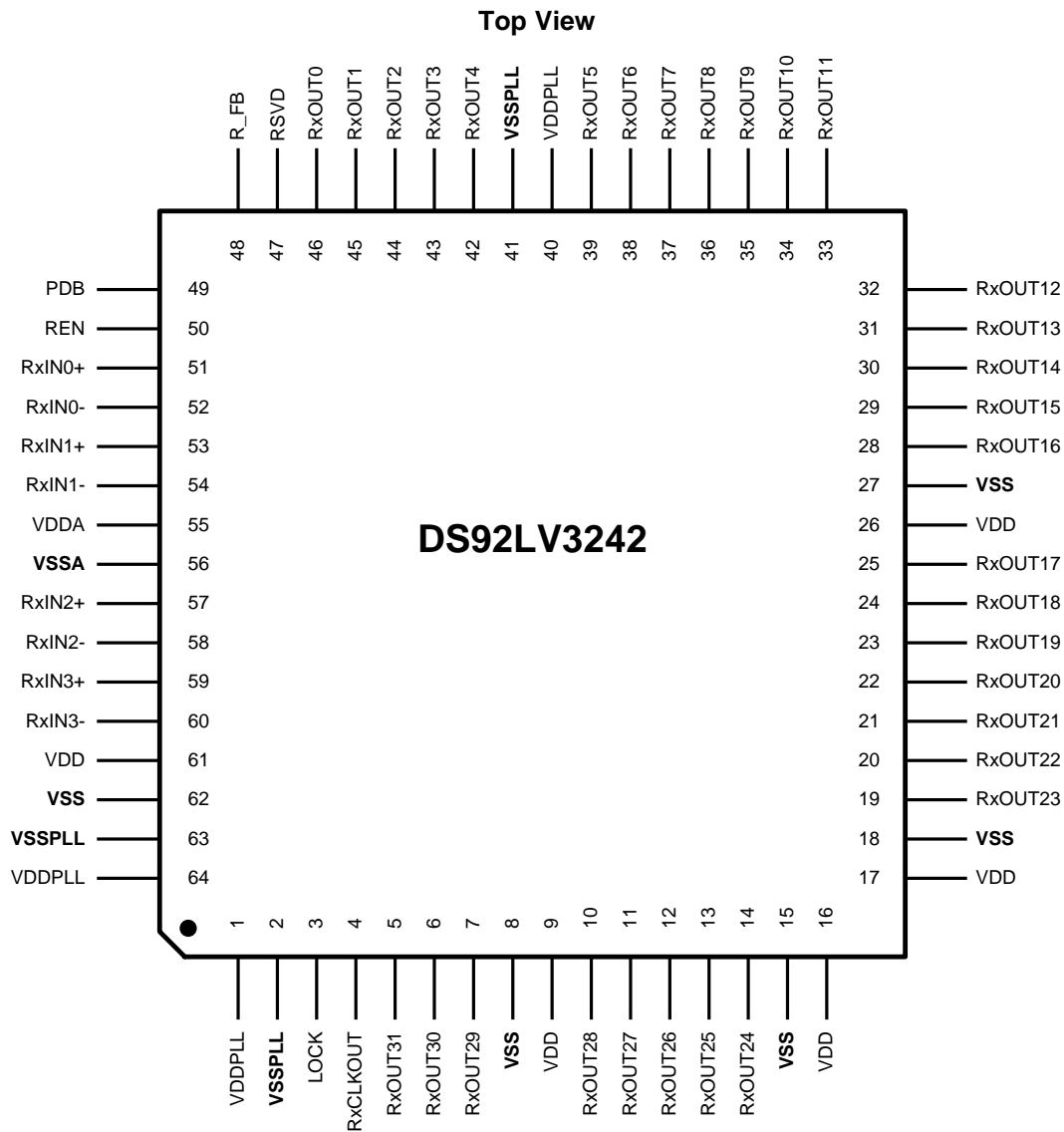

Figure 4. DS92LV3242 Pin Diagram  
64-Pin TQFP (PAG Package)

**DS92LV3242 Deserializer PIN DESCRIPTIONS**

Pin #	Pin Name	I/O, Type	Description
<b>LVCMOS PARALLEL INTERFACE PINS</b>			
5–7, 10–14, 19–25, 28–32, 33–39, 42–46	RxOUT[31:29], RxOUT[28:24], RxOUT[23:17], RxOUT[16:12], RxOUT[11:5], RxOUT[4:0]	O, LVCMOS	Deserializer Parallel Interface Data Output Pins.
4	RxCLKOUT	O, LVCMOS	Deserializer Recovered Clock Output. Parallel data rate clock recovered from the embedded clock.
3	LOCK	O, LVCMOS	LOCK indicates the status of the receiver PLL LOCK = L; deserializer CDR/PLL is not locked, RxOUT[31:0] and RCLK are TRI-STATE LOCK = H; deserializer CDR/PLL is locked
<b>CONTROL AND CONFIGURATION PINS</b>			
48	R_FB	I, LVCMOS	Rising/Falling Bar Clock Edge Select R_FB = H; RxOUT clocked on rising edge R_FB = L; RxOUT clocked on falling edge
50	REN	I, LVCMOS	Deserializer Enable, DES Output Enable Control Input (ACTIVE HIGH) REN = L; disabled, RxOUT[31:0] and RxCLKOUT TRI-STATE, PLL still operational REN = H; Enabled (ACTIVE HIGH)
49	PDB	I, LVCMOS	Power Down Bar, Control Input Signal (ACTIVE LOW) PDB = L; disabled, RxOUT[31:0], RCLK, and LOCK are TRI-STATE in stand-by mode, PLL is shutdown PDB = H; Enabled
47	RSVD	I, LVCMOS	Reserved — MUST BE TIED LOW
<b>LVDS SERIAL INTERFACE PINS</b>			
51, 53, 57, 59	RxIN[0:3]+	I, LVDS	Deserializer LVDS Non-Inverted Inputs(+)
52, 54, 58, 60	RxIN[0:3]-	I, LVDS	Deserializer LVDS Inverted Inputs(-)
<b>POWER / GROUND PINS</b>			
9, 16, 17, 26, 61	VDD	VDD	Digital Voltage supply, 3.3V
8, 15, 18, 27, 62	VSS	GND	Digital Ground
55	VDDA	VDD	Analog LVDS Voltage supply, POWER, 3.3V
56	VSSA	GND	Analog LVDS GROUND
1, 40, 64	VDDPLL	VDD	Analog Voltage supply PLL VCO POWER, 3.3V
2, 41, 63	VSSPLL	GND	Analog ground, PLL VCO GROUND



These devices have limited built-in ESD protection. The leads should be shorted together or the device placed in conductive foam during storage or handling to prevent electrostatic damage to the MOS gates.

**Absolute Maximum Ratings<sup>(1)(2)</sup>**

Supply Voltage ( $V_{DD}$ )	-0.3V to +4V
LVC MOS Input Voltage	-0.3V to ( $V_{DD} + 0.3V$ )
LVC MOS Output Voltage	-0.3V to ( $V_{DD} + 0.3V$ )
LVDS Deserializer Input Voltage	-0.3V to +3.9V
LVDS Driver Output Voltage	-0.3V to +3.9V
Junction Temperature	+125°C
Storage Temperature	-65°C to +150°C
Lead Temperature (Soldering, 4 seconds)	+260°C
Maximum Package Power Dissipation Capacity Package Derating	$1/\theta_{JA}$ °C/W above +25°C
$\theta_{JA}$	35.7 °C/W <sup>(3)</sup>
$\theta_{JC}$	12.6 °C/W
ESD Rating (HBM)	>4 kV

- (1) "Absolute Maximum Ratings" indicate limits beyond which damage to the device may occur, including inoperability and degradation of device reliability and/or performance. Functional operation of the device and/or non-degradation at the Absolute Maximum Ratings or other conditions beyond those indicated in the Recommended Operating Conditions is not implied. The Recommended Operating Conditions indicate conditions at which the device is functional and the device should not be operated beyond such conditions.
- (2) If Military/Aerospace specified devices are required, please contact the Texas Instruments Sales Office/ Distributors for availability and specifications.
- (3) 4 Layer JEDEC

**Recommended Operating Conditions**

		Min	Nom	Max	Units
Supply Voltage ( $V_{DD}$ )		3.135	3.3	3.465	V
Supply Voltage ( $IOV_{DD}$ ) (SER ONLY)	3.3V I/O Interface	3.135	3.3	3.465	V
	1.8V I/O Interface	1.71	1.8	1.89	V
Operating Free Air Temperature ( $T_A$ )		-40	+25	+85	°C
Input Clock Rate	Dual Mode	20		50	MHz
	Quad Mode	40		85	MHz
Tolerable Supply Noise				100	mV <sub>P-P</sub>

## Electrical Characteristics<sup>(1)(2)</sup>

Over recommended operating supply and temperature ranges unless otherwise specified.

Symbol	Parameter	Conditions	Min	Typ	Max	Units
<b>LVC MOS DC SPECIFICATIONS</b>						
V <sub>IH</sub>	High Level Input Voltage	Tx: IOV <sub>DD</sub> = 1.71V to 1.89V	0.65 x IOV <sub>DD</sub>		IOV <sub>DD</sub> + 0.3	V
		Tx: IOV <sub>DD</sub> = 3.135V to 3.465V	2.0		V <sub>DD</sub>	
		Rx				
V <sub>IL</sub>	Low Level Input Voltage	Tx: IOV <sub>DD</sub> = 1.71V to 1.89V	GND		0.35 x IOV <sub>DD</sub>	V
		Tx: IOV <sub>DD</sub> = 3.135V to 3.465V	GND		0.8	
		Rx				
V <sub>CL</sub>	Input Clamp Voltage	I <sub>CL</sub> = -18 mA		-0.8	-1.5	V
I <sub>IN</sub>	Input Current	Tx: V <sub>IN</sub> = 0V or 3.465V(1.89V) IOV <sub>DD</sub> = 3.465V(1.89V)	-10		+10	μA
		Rx: V <sub>IN</sub> = 0V or 3.465V	-10		+10	
V <sub>OH</sub>	High Level Output Voltage	I <sub>OH</sub> = -2mA (Dual)	2.4	3.0	V <sub>DD</sub>	V
		I <sub>OH</sub> = -2mA (Quad)				
V <sub>OL</sub>	Low Level Output Voltage	I <sub>OH</sub> = -2mA (Dual)	GND	0.33	0.5	V
		I <sub>OH</sub> = -2mA (Quad)				
I <sub>OS</sub>	Output Short Circuit Current	V <sub>OUT</sub> = 0V (Dual)		-22	-40	mA
		V <sub>OUT</sub> = 0V (Quad)		-33	-70	mA
I <sub>OZ</sub>	TRI-STATE Output Current	PDB = 0V, V <sub>OUT</sub> = 0V or V <sub>DD</sub>	-10		+10	μA
<b>SERIALIZER LVDS DC SPECIFICATIONS</b>						
V <sub>OD</sub>	Output Differential Voltage	No pre-emphasis, VSEL = L (VSEL = H)	350 (629)	440 (850)	525 (1000)	mV <sub>P-P</sub>
ΔV <sub>OD</sub>	Output Differential Voltage Unbalance	VSEL = L, No pre-emphasis		1	50	mV <sub>P-P</sub>
V <sub>OS</sub>	Offset Voltage	VSEL = L, No pre-emphasis	1.00	1.25	1.50	V
ΔV <sub>OS</sub>	Offset Voltage Unbalance	VSEL = L, No pre-emphasis		4	50	mV
I <sub>OS</sub>	Output Short Circuit Current	TxOUT[3:0] = 0V, PDB = V <sub>DD</sub> , VSEL = L, No pre-emphasis	-2	-5		mA
		TxOUT[3:0] = 0V, PDB = V <sub>DD</sub> , VSEL = H, No pre-emphasis	-6	-10		
I <sub>OZ</sub>	TRI-STATE Output Current	PDB = 0V, TxOUT[3:0] = 0V OR V <sub>DD</sub>	-15	±1	+15	μA
		PDB = V <sub>DD</sub> , TxOUT[3:0] = 0V OR V <sub>DD</sub>	-15	±1	+15	μA
R <sub>T</sub>	Output Termination	Internal differential output termination between differential pairs	90	100	130	Ω
<b>SERIALIZER SUPPLY CURRENT (DVDD, PVDD AND AVDD PINS)<sup>(3)</sup></b>						
I <sub>DDTQ</sub>	Serializer (Tx) Total Supply Current Quad Mode (includes load current)	f = 85 MHz, CHECKER BOARD pattern MODE = H, VSEL = H, PRE = OFF		150	200	mA
		f = 85 MHz, CHECKER BOARD pattern MODE = H, VSEL = H, RPRE = 12 kΩ		150	200	
		f = 85 MHz, RANDOM pattern MODE = H, VSEL = H, PRE = OFF		140	195	
		f = 85 MHz, RANDOM pattern MODE = H, VSEL = H, RPRE = 12 kΩ		140	195	

(1) Typical values represent most likely parametric norms at V<sub>DD</sub> = 3.3V, T<sub>A</sub> = +25°C, and at the Recommended Operating Conditions at the time of product characterization and are not verified.

(2) Current into a the device is defined as positive. Current out of a device pin is defined as negative. Voltages are referenced to ground except V<sub>OD</sub>, ΔV<sub>OD</sub>, V<sub>TH</sub>, V<sub>TL</sub> which are differential voltages.

(3) DIGITAL, PLL, AND ANALOG VDDS

**Electrical Characteristics<sup>(1)(2)</sup> (continued)**

Over recommended operating supply and temperature ranges unless otherwise specified.

Symbol	Parameter	Conditions	Min	Typ	Max	Units
I <sub>DDTD</sub>	Serializer (Tx) Total Supply Current Dual Mode (includes load current)	f = 50 MHz, CHECKER BOARD pattern MODE = L, VSEL = H, PRE = OFF		120	145	mA
		f = 50 MHz, CHECKER BOARD pattern MODE = H, VSEL = H, RPRE = 12 kΩ		120	145	
		f = 50 MHz, RANDOM pattern MODE = L, VSEL = H, PRE = OFF		115	135	
		f = 50 MHz, RANDOM pattern MODE = L, VSEL = H, RPRE = 12 kΩ		115	135	
I <sub>DDTZ</sub>	Serializer Supply Current Power-down	TPWDNB = 0V (All other LVCMOS Inputs = 0V)		2	50	μA
<b>DESERIALIZER LVDS DC SPECIFICATIONS</b>						
V <sub>TH</sub>	Differential Threshold High Voltage	V <sub>CM</sub> = +1.8V			+50	mV
V <sub>TL</sub>	Differential Threshold Low Voltage		-50			mV
R <sub>T</sub>	Input Termination	Internal differential output termination between differential pairs	90	100	130	Ω
I <sub>IN</sub>	Input Current	V <sub>IN</sub> = +2.4V, V <sub>DD</sub> = 3.6V		±100	±250	μA
		V <sub>IN</sub> = 0V, V <sub>DD</sub> = 3.6V		±100	±250	μA
<b>DESERIALIZER SUPPLY CURRENT (DVDD, PVDD AND AVDD PINS)<sup>(4)</sup></b>						
I <sub>DDR</sub>	Deserializer Total Supply Current (includes load current)	f = 85 MHz, C <sub>L</sub> = 8 pF, CHECKER BOARD pattern, Quad Mode		240	265	mA
		f = 85 MHz, C <sub>L</sub> = 8 pF, RANDOM pattern, Quad Mode		190	210	
		f = 50 MHz, C <sub>L</sub> = 8 pF, CHECKER BOARD pattern, Dual Mode		145	185	mA
		f = 50 MHz, C <sub>L</sub> = 8 pF, RANDOM pattern, Dual Mode		122	140	
I <sub>DDRZ</sub>	Deserializer Supply Current Power-down	PDB = 0V (All other LVCMOS Inputs = 0V, RxIN[3:0](P/N) = 0V)			100	μA

(4) DIGITAL, PLL, AND ANALOG VDDS

**Serializer Input Timing Requirements for TCLK**

Over recommended operating supply and temperature ranges unless otherwise specified.

Symbol	Parameter	Conditions	Min	Typ	Max	Units
t <sub>CIP</sub>	TxCLKIN Period	MODE = L (Dual Mode)	20	t <sub>CIP</sub>	50	ns
		MODE = H (Quad Mode)	11.76	t <sub>CIP</sub>	25	
t <sub>CIH</sub>	TxCLKIN High Time	20 MHz – 50 MHz	0.45 x t <sub>CIP</sub>	0.5 x t <sub>CIP</sub>	0.55 x t <sub>CIP</sub>	ns
		40 MHz – 85 MHz	0.45 x t <sub>CIP</sub>	0.5 x t <sub>CIP</sub>	0.55 x t <sub>CIP</sub>	
t <sub>TCIL</sub>	TxCLKIN Low Time	20 MHz – 50 MHz <a href="#">Figure 7</a>	0.45 x t <sub>CIP</sub>	0.5 x t <sub>CIP</sub>	0.55 x t <sub>CIP</sub>	ns
		40 MHz – 85 MHz	0.45 x t <sub>CIP</sub>	0.5 x t <sub>CIP</sub>	0.55 x t <sub>CIP</sub>	
t <sub>CIT</sub>	TxCLKIN Transition Time	20 MHz – 50 MHz <a href="#">Figure 6</a>	0.5		1.2	ns
		40 MHz – 85 MHz	0.5		1.2	
t <sub>JIT</sub>	TxCLKIN Jitter				±100	pSp-p

## Serializer Switching Characteristics

Over recommended operating supply and temperature ranges unless otherwise specified.

Symbol	Parameter	Conditions	Min	Typ	Max	Units	
$t_{LLHT}$	LVDS Low-to-High Transition Time	No pre-emphasis Figure 5		350		ps	
$t_{LHLT}$	LVDS High-to-Low Transition Time			350		ps	
$t_{STC}$	TxIN[31:0] Setup to TxCLKIN	IOVDD = 1.71V to 1.89V Figure 7	0			ns	
		IOVDD = 3.135V to 3.465V	0				
$t_{HTC}$	TxIN[31:0] Hold from TxCLKIN	IOVDD = 1.71V to 1.89V	2.5			ns	
		IOVDD = 3.135V to 3.465V	2.25				
$t_{PLD}$	Serializer PLL Lock Time	Figure 9		4400 x $t_{CIP}$	5000 x $t_{CIP}$	ns	
$t_{LZD}$	Data Output LOW to TRI-STATE Delay	See <sup>(1)</sup>		5	10	ns	
$t_{HZD}$	Data Output TRI-STATE to HIGH Delay	See <sup>(1)</sup>		5	10	ns	
$t_{SD}$	Serializer Propagation Delay - Latency	f = 50 MHz, R_FB = H, PRE = OFF, MODE = L Figure 8		4.5 $t_{CIP}$ + 6.77			ns
		f = 50 MHz, R_FB = L, PRE = OFF, MODE = L	4.5 $t_{CIP}$ + 5.63	4.5 $t_{CIP}$ + 7.09	4.5 $t_{CIP}$ + 9.29		
		f = 20 MHz, R_FB = H, PRE = OFF, MODE = L	4.5 $t_{CIP}$ + 6.57	4.5 $t_{CIP}$ + 8.74	4.5 $t_{CIP}$ + 10.74		
		f = 85MHz, R_FB = H, PRE = OFF, MODE = H		9.0 $t_{CIP}$ + 6.99			
		f = 85MHz, R_FB = L, PRE = OFF, MODE = H	9.0 $t_{CIP}$ + 5.97	9.0 $t_{CIP}$ + 7.38	9.0 $t_{CIP}$ + 9.64		
		f = 40 MHz, R_FB = HL, PRE = OFF, MODE = H	9.0 $t_{CIP}$ + 6.30	9.0 $t_{CIP}$ + 8.26	9.0 $t_{CIP}$ + 10.49		
$t_{LVSKD}$	LVDS Output Skew	LVDS differential output channel-to-channel skew		30	500	ps	
$\Lambda_{STXBW}$	Jitter Transfer Function -3 dB Bandwidth	Dual Mode f = 50 MHz Figure 15		2.8		MHz	
		Quad Mode f = 85 MHz		2			
$\delta_{STX}$	Serializer Jitter Transfer Function Peaking	Dual Mode f = 50 MHz		0.3		dB	
		Quad Mode f = 85 MHz		0.9			

(1) When the Serializer output is at TRI-STATE the Deserializer will lose PLL lock. Resynchronization MUST occur before data transfer.

## Deserializer Switching Characteristics

Over recommended operating supply and temperature ranges unless otherwise specified.

Symbol	Parameter	Conditions	Min	Typ	Max	Units
$t_{ROCP}$	Receiver Output Clock Period	$t_{ROCP} = t_{CIP}$ (Dual Mode) Figure 11	20	$t_{ROCP}$	50	ns
		$t_{ROCP} = t_{CIP}$ (Quad Mode)	11.76	$t_{ROCP}$	25	
$t_{RODC}$	RxCLKOUT Duty Cycle		45	50	55	%
$t_{ROTR}$	LVC MOS Low-to-High Transition Time	$C_L = 8\text{pF}$ (lumped load) (Dual Mode) Figure 10		3.2		ns
$t_{ROTF}$	LVC MOS High-to-Low Transition Time			3.5		ns
$t_{ROTR}$	LVC MOS Low-to-High Transition Time	$C_L = 8\text{pF}$ (lumped load) (Quad Mode)		2.4		ns
$t_{ROTF}$	LVC MOS High-to-Low Transition Time			1.9		ns
$t_{ROSC}$	RxOUT[31:0] Setup to RxCLKOUT	$f = 50\text{ MHz}$ (Dual Mode)	5.6	$0.5 \times t_{ROCP}$		ns
$t_{ROHC}$	RxOUT[31:0] Hold to RxCLKOUT		7.4	$0.5 \times t_{ROCP}$		ns
$t_{ROSC}$	RxOUT[31:0] Setup to RxCLKOUT	$f = 85\text{ MHz}$ (Quad Mode)	3.4	$0.5 \times t_{ROCP}$		ns
$t_{ROHC}$	RxOUT[31:0] Hold to RxCLKOUT		3.4	$0.5 \times t_{ROCP}$		ns
$t_{HZR}$	Data Output High to TRI-STATE Delay	Figure 13		5	10	ns
$t_{LZR}$	Data Output Low to TRI-STATE Delay			5	10	ns
$t_{ZHR}$	Data Output TRI-STATE to High Delay			5	10	ns
$t_{ZLR}$	Data Output TRI-STATE to Low Delay			5	10	ns
$t_{RD}$	Deserializer Propagation Delay – Latency	$f = 20\text{ MHz}$ (Dual Mode) Figure 12		$5.5 \times t_{ROCP} + 3.35$		ns
		$f = 50\text{ MHz}$ (Dual Mode)		$5.5 \times t_{ROCP} + 6.00$		ns
		$f = 40\text{ MHz}$ (Quad Mode)		$12.0 \times t_{ROCP} + 7.4$		ns
		$f = 85\text{ MHz}$ (Quad Mode)		$12.0 \times t_{ROCP} + 5.7$		ns
$t_{RPLLS}^{(1)}$	Deserializer PLL Lock Time	20 MHz – 50 MHz (Dual Mode) Figure 13			$128\text{k} \times t_{ROCP}$	ns
		40 MHz – 85 MHz (Quad Mode) Figure 13			$256\text{k} \times t_{ROCP}$	ns
TOL <sub>JIT</sub>	Deserializer Input Jitter Tolerance			0.25		UI
$t_{LVSKR}$	LVDS Differential Input Skew Tolerance	20 MHz – 85 MHz Figure 17			$0.4 \times t_{ROCP}$	ns

(1)  $t_{RPLLS}$  is the time required by the Deserializer to obtain lock when exiting power-down mode.

AC Timing Diagrams and Test Circuits

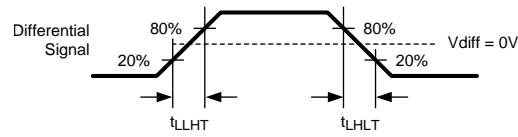

Figure 5. Serializer LVDS Transition Times

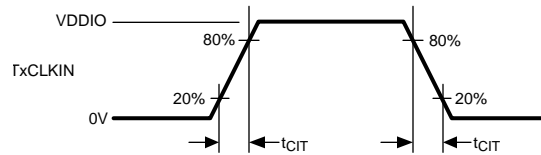

Figure 6. Serializer Input Clock Transition Time

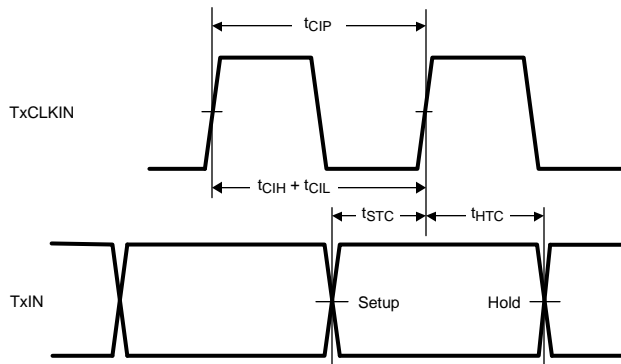

Figure 7. Serializer Setup/Hold and High/Low Times

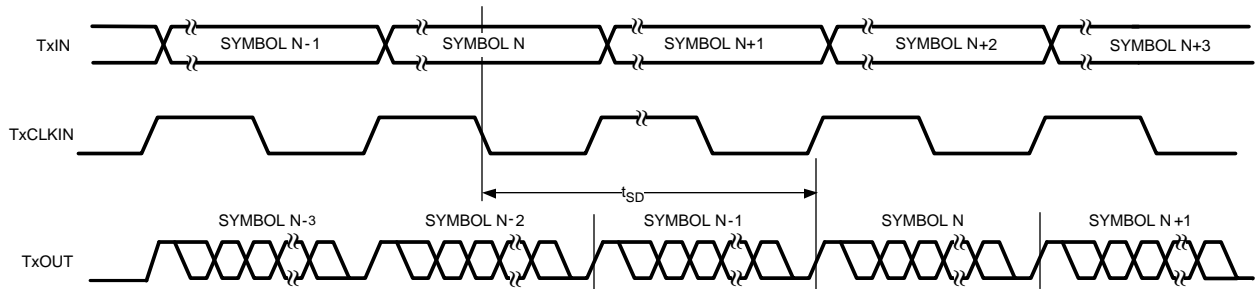

Figure 8. Serializer Propagation Delay

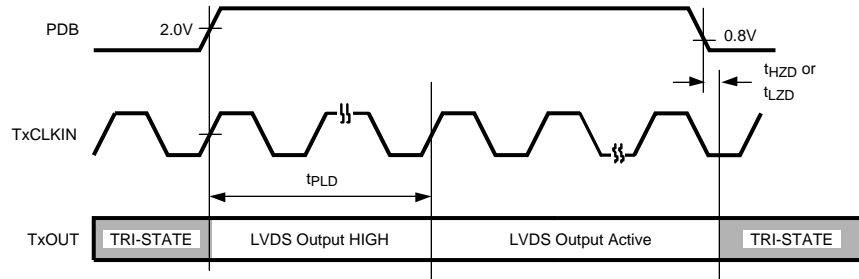

Figure 9. Serializer PLL Lock Time

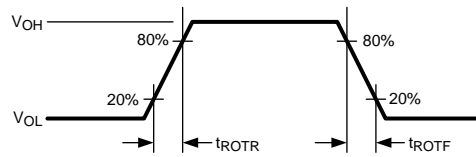

Figure 10. Deserializer LVC MOS Output Transition Time

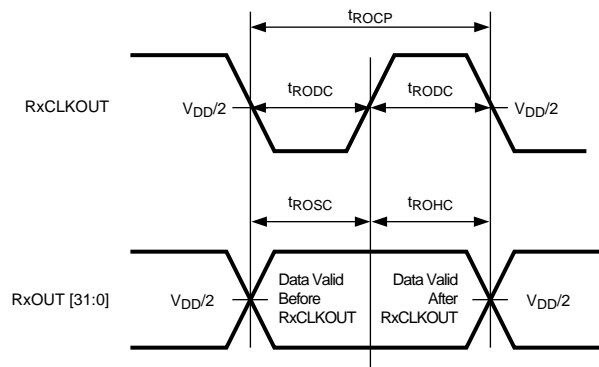

Figure 11. Deserializer Setup and Hold times

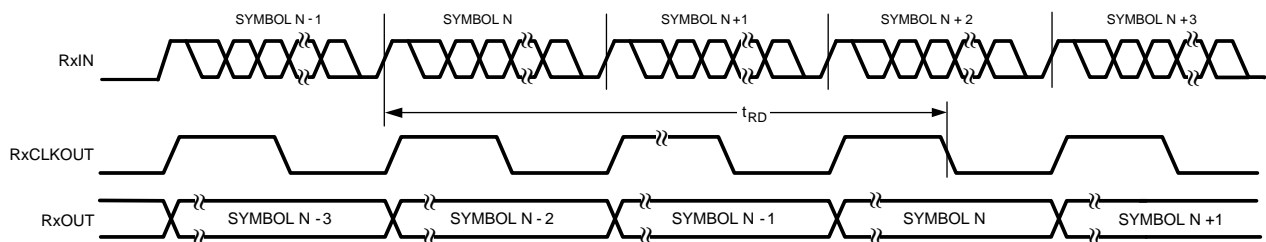

Figure 12. Deserializer Propagation Delay

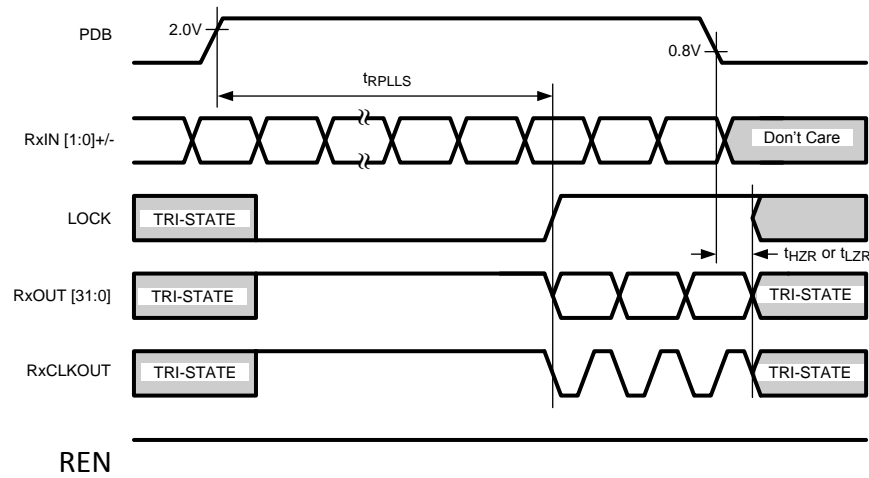

Figure 13. Deserializer PLL Lock Time and PDB TRI-STATE Delay

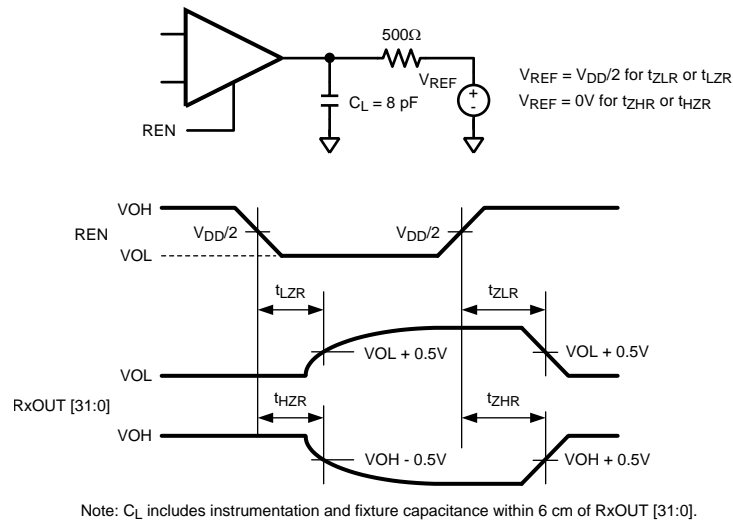

Figure 14. Deserializer TRI\_STATE Test Circuit and Timing

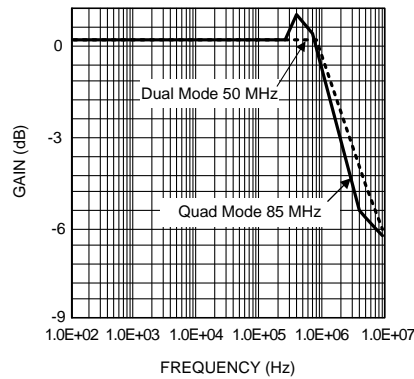

Figure 15. Serializer Jitter Transfer

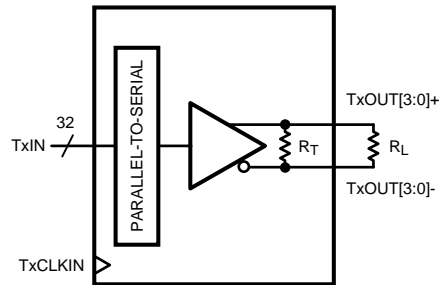

Figure 16. Serializer  $V_{OD}$  Test Circuit Diagram

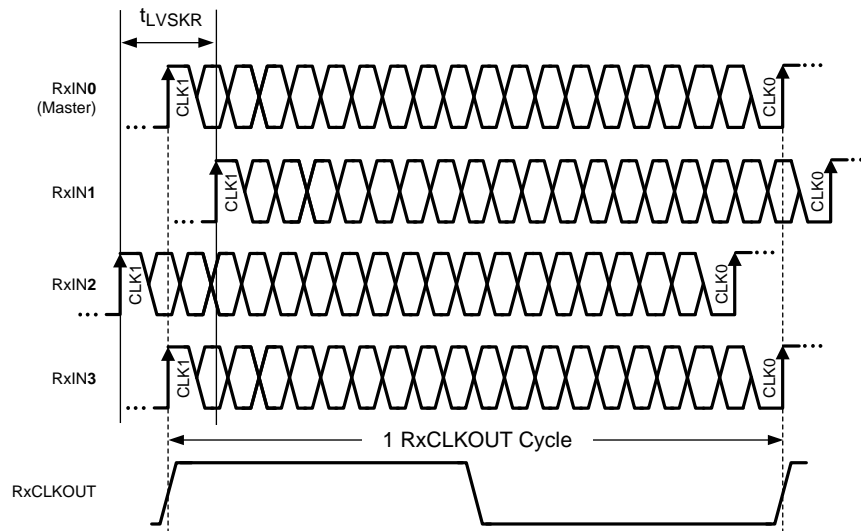

Figure 17. LVDS Deserializer Input Skew

## FUNCTIONAL DESCRIPTION

The DS92LV3241 Serializer (SER) and DS92LV3242 Deserializer (DES) chipset is a flexible SER/DES chipset that translates a 32-bit parallel LVCMOS data bus into a quad (4 pairs) or dual (2 pairs) LVDS serial links with embedded clock. The DS92LV3241 serializes the 32-bit wide parallel LVCMOS word into four or two high-speed LVDS serial data streams with embedded clock, scrambles and DC Balances the data to support AC coupling and enhance signal quality. The DS92LV3242 receives the dual/quad LVDS serial data streams and converts it back into a 32-bit wide parallel data with a recovered clock. The dual/quad LVDS serial data stream reduces cable size, the number of connectors, and eases skew concerns.

Parallel clocks between 20 MHz to 85 MHz are supported by the dual or quad operating modes. The modes are user selectable through a control pin on Serializer. In dual mode, the transmit clock frequency supports 20 MHz to 50 MHz and in quad mode the transmit clock frequency supports 40 MHz to 85 MHz. In the dual mode configuration, the embedded clock LVDS serial streams have an effective data payload of 640 Mbps (20MHz x 32-bit) to 1.6 Gbps (50MHz x 32-bit). In the quad mode configuration, the embedded clock LVDS serial streams have an effective data payload of 1.28 Gbps (40MHz x 32-bit) to 2.72 Gbps (85MHz x 32-bit). The SER/DES chipset is designed to transmit data over long distances through standard twisted pair (TWP) cables. The differential inputs and outputs are internally terminated with 100 ohm resistors to provide source and load termination, minimize stub length, to reduce component count and further minimize board space.

The DES can attain lock to a data stream without the use of a separate reference clock source; greatly simplifying system complexity and reducing overall cost. The DES synchronizes to the SER regardless of data pattern, delivering true automatic “plug-and-lock” performance. It will lock to the incoming serial stream without the need of special training patterns or special sync characters. The DES recovers the clock and data by extracting the embedded clock information, deskews the serial data channels and then deserializes the data. The DES also monitors the incoming clock information, determines lock status, and asserts the LOCK output high when lock occurs. In addition the DES also supports an optional AT-SPEED BIST (Built In Self Test) mode, BIST error flag, and LOCK status reporting pin. The SER and the DES have a power down control signal to enable efficient operation in various applications.

## DESKEW AND CHANNEL ALIGNMENT

The DES automatically detects dual or quad serial channel mode and provides a clock alignment and deskew function without the need for any special training patterns. During the locking phase, the embedded clock information is recovered on all channels and the serial links are internally synchronized, de-skewed, and auto aligned. The internal CDR circuitry will dynamically compensate for up to 0.4 times the parallel clock period of per channel phase skew (channel-to-channel) between the recovered clocks of the serial links. This provides skew phase tolerance from mismatches in interconnect wires such as PCB trace routing, cable pair-to-pair length differences, and connector imbalances.

## DATA TRANSFER

After SER lock is established (SER PLL to TxCLKIN), the inputs TxIN0–TxIN31 are latched into the encoder block. Data is clocked into the SER by the TxCLKIN input. The edge of TxCLKIN used to strobe the data is selectable via the R\_FB (SER) pin. R\_FB (SER) high selects the rising edge for clocking data and low selects the falling edge. The SER outputs (TxOUT[3:0]+/-) are intended to drive a AC Coupled point-to-point connections.

The SER latches 32-bit parallel data bus and performs several operations to it. The 32-bit parallel data is internally encoded and sequentially transmitted over the two high-speed serial LVDS channels. For each serial channel, the SER transmits 20 bits of information per payload to the DES. In the dual mode, the 32-bit parallel data is scaled and bit-mapped across two 20-bit data payloads per channel, resulting in a per channel throughput of 400 Mbps to 1.0 Gbps (20 bits x clock rate). Under quad mode, the internal PLL operates at ½ the input clock frequency rate. The 32 bits are bit-mapped and sequenced per every 2 cycles at ½ the TxCLKIN frequency across four channels, resulting in a per channel throughput of 400 Mbps to 850 Mbps (20 bits x clock rate/2). The chipset supports frequency ranges of 20 MHz to 85 MHz.

When all of the DES channels obtain lock, the LOCK pin is driven high and synchronously delivers valid data and recovered clock on the output. The DES locks to the clock, uses it to generate multiple internal data strobes, and then drives the recovered clock to the RxCLKOUT pin. The recovered clock (RxCLKOUT) is synchronous to the data on the RxOUT[31:0] pins. While LOCK is high, data on RxOUT[31:0] is valid. Otherwise, RxOUT[31:0] is invalid. The polarity of the RxCLKOUT edge is controlled by its R\_FB (DES) input. RxOUT[31:0], LOCK and RxCLKOUT outputs will each drive a maximum of 8 pF load. REN controls TRI-STATE for RxOUT0–RxOUT31 and the RxCLKOUT pin on the DES.

## RESYNCHRONIZATION

In the absence of data transitions on one of the channels into the DES (e.g. a loss of the link), it will automatically try to resynchronize and re-establish lock using the standard lock sequence on the master channel (Channel 0). For example, if the embedded clock is not detected one time in succession on any of the serial links, the LOCK pin is driven low. The DES then monitors the master channel for lock, once that is obtained, the second channel is locked and aligned. The logic state of the LOCK signal indicates whether the data on RxOUT is valid; when it is high, the data is valid. The system may monitor the LOCK pin to determine whether data on the RxOUT is valid.

## POWERDOWN

The Powerdown state is a low power sleep mode that the SER and DES may use to reduce power when no data is being transferred. The respective PDB pins are used to set each device into power down mode, which reduces supply current into the  $\mu$ A range. The SER enters Powerdown when the SER PDB pin is driven low. In Powerdown, the PLL stops and the outputs go into TRI-STATE, disabling load current and reducing current supply. To exit Powerdown, SER PDB must be driven high. When the SER exits Powerdown, its PLL must lock to TxCLKIN before it is ready for sending data to the DES. The system must then allow time for the DES to lock before data can be recovered.

The DES enters Powerdown mode when DES PDB is driven low. In Powerdown mode, the PLL's stop and the outputs enter TRI-STATE. To bring the DES block out of the Powerdown state, the system drives DES PDB high. Both the SER and DES must relock before data can be transferred from Host and received by the Target. The DES will startup and assert LOCK high when it is locked to the embedded clocks. See also [Figure 13](#).

## TRI-STATE

For the SER, TRI-STATE is entered when the SER PDB pin is driven low. This will TRI-STATE the driver output pins on TxOUT[3:0]±. In addition, when MODE=0 (dual mode), the TxOUT[3:2]± outputs pins are in TRI-STATE.

When you drive the REN or DES PDB pin low, the DES output pins (RxOUT[31:0]) and RxCLKOUT will enter TRI-STATE. The LOCK output remains active, reflecting the state of the PLL. The DES input pins are high impedance during receiver Powerdown (DES PDB low) and power-off (VDD = 0V). See also [Figure 13](#).

## TRANSMIT PARALLEL DATA AND CONTROL INPUTS

The DS92LV3241 operates on a core supply voltage of 3.3V with an optional digital supply voltage for 1.8V, low-swing, input support. The SER single-ended (32-bit parallel data and control inputs) pins are 1.8V and 3.3V LVCMOS logic level compatible and is configured through the IOVDD input supply rail. If 1.8V is required, the IOVDD pin must be connected to a 1.8V supply rail. Also when power is applied to the transmitter, IOVDD pin must be applied before or simultaneously with other power supply pins (3.3V). If 1.8V input swing is not required, this pin should be tied to the common 3.3V rail. During normal operation, the voltage level on the IOVDD pins must not change.

## PRE-EMPHASIS

The SER LVDS Line Driver features a Pre-Emphasis function used to compensate for extra long or lossy transmission media. The same amount of Pre-Emphasis is applied on all of the enabled differential output channels. Cable drive is enhanced with a user selectable Pre-Emphasis feature that provides additional output current during transitions to counteract cable loading effects. The transmission distance will be limited by the loss characteristics and quality of the media.

To enable the Pre-Emphasis function, the “PRE” pin requires one external resistor ( $R_{pre}$ ) to VSS (GND) in order to set the pre-emphasized current level. Options include:

1. Normal Output (no Pre-emphasis) – Leave the PRE pin open, include an R pad, do not populate.
2. Enhanced Output (Pre-emphasis enabled) – connect a resistor on the PRE pin to Vss.

Values of the  $R_{pre}$  Resistor should be between 12K Ohm and 100K Ohm. Values less than 6K Ohm should not be used. The amount of Pre-Emphasis for a given media will depend on the transmission distance and  $F_{max}$  of the application. In general, too much Pre-Emphasis can cause over or undershoot at the receiver input pins. This can result in excessive noise, crosstalk, reduced  $F_{max}$ , and increased power dissipation. For shorter cables or distances, Pre-Emphasis is typically not required. Signal quality measurements should be made at the end of the application cable to confirm the proper amount of Pre-Emphasis for the specific application.

The Pre-Emphasis circuit increases the drive current to  $I = 48 / (R_{PRE})$ . For example if  $R_{PRE} = 15$  kOhms, then the current is increased by an additional 3.2 mA. To calculate the expected increase in  $V_{OD}$ , multiply the increase in current by 50 ohms. So for the case of  $R_{PRE} = 15$  kOhms, the boost to  $V_{OD}$  would be 3.2 mA x 50 Ohms = 160 mV. The duration of the current is controlled to one bit by time. If more than one bit value is repeated in the next cycle(s), the Pre-Emphasis current is turned off (back to the normal output current level) for the next bit(s). To boost high frequency data and pre-equalize the data pattern reduce ISI (Inter-Symbol Interference) improving the resulting eye pattern.

### V<sub>OD</sub> SELECT

The SER Line Driver Differential Output Voltage ( $V_{OD}$ ) magnitude is selectable. Two levels are provided and are selected by the VSEL pin. When this pin is LOW, normal output levels are obtained. For most application set the VSEL pin LOW. When this pin is HIGH, the output current is increased to double the  $V_{OD}$  level. Use this setting only for extra long cables or high-loss interconnects.

**Table 1. VOD Control**

VSEL Pin Setting	Effect
LOW	Small $V_{OD}$ , typ 440 mV <sub>P-P</sub>
HIGH	Large $V_{OD}$ , typ 850 mV <sub>P-P</sub>

### SERIAL INTERFACE

The serial links between the DS92LV3241 and the DS92LV3242 are intended for a balanced 100 Ohm interconnects. The links **must** be configured as an AC coupled interface.

The SER and DES support AC-coupled interconnects through an integrated DC balanced encoding/decoding scheme. An external AC coupling capacitors must be placed, in series, in the LVDS signal path. The DES input stage is designed for AC-coupling by providing a built-in AC bias network which sets the internal common mode voltage (VCM) to +1.8V.

For the high-speed LVDS transmission, small footprint packages should be used for the AC coupling capacitors. This will help minimize degradation of signal quality due to package parasitics. NPO class 1 or X7R class 2 type capacitors are recommended. 50 WVDC should be the minimum used for best system-level ESD performance. The most common used capacitor value for the interface is 100 nF (0.1 uF) capacitor. One set of capacitors may be used for isolation. Two sets (both ends) may also be used for maximum isolation of both the SER and DES from cable faults.

The DS92LV3241 and the DS92LV3242 differential I/O's are internally terminated with 100 Ohm resistance between the inverting and non-inverting pins and do not require external termination. The internal resistance value will be between 90 ohm and 130 ohm. The integrated terminations improve signal integrity, reduce stub lengths, and decrease the external component count resulting in space savings.

## AT-SPEED BIST FEATURE

The DS92LV3241/ DS92LV3242 serial link is equipped with built-in self-test (BIST) capability to support both system manufacturing and field diagnostics. BIST mode is intended to check the entire high-speed serial interface at full link-speed without the use of specialized and expensive test equipment. This feature provides a simple method for a system host to perform diagnostic testing of both SER and DES. The BIST function is easily configured through the SER BISTEN pin. When the BIST mode is activated, the SER generates a PRBS (pseudo-random bit sequence) pattern ( $2^7-1$ ). This pattern traverses each lane to the DES input. The DS92LV3242 includes an on-chip PRBS pattern verification circuit that checks the data pattern for bit errors and reports any errors on the data output pins of the DES.

The AT-Speed BIST feature is enabled by setting the BISTEN to High on SER. The BISTEN input must be High or Low for 4 or more TxCLKIN clock cycles in order to activate or deactivate the BIST mode. An input clock signal for the Serializer TxCLKIN must also be applied during the entire BIST operation. Once BIST is enabled, all the Serializer data inputs (TxIN[31:0]) are ignored and the DES outputs (RxOUT[31:0]) are not available. Next, the internal test pattern generator for each channel starts transmission of the BIST pattern from SER to DES. The DES BIST mode will be automatically activated by this sequence. A maximum of 128 consecutive clock symbols on DS92LV3242 DES is needed to detect BIST enable function. The BIST is implemented with independent transmit and receive paths for the four serial links. Each channel on the DES will be individually compared against the expected bit sequence of the BIST pattern.

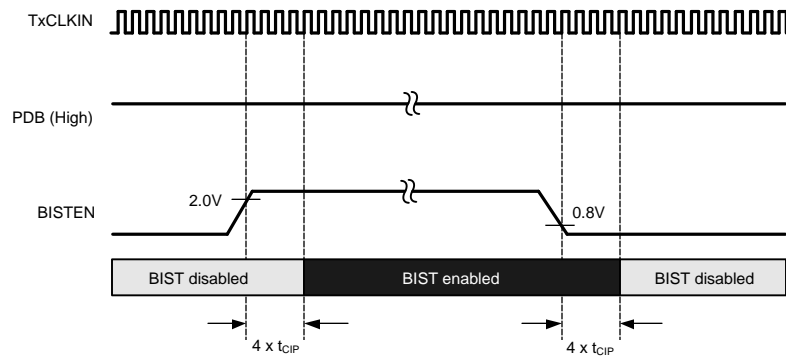

Figure 18. BIST Test Enabled/Disabled

Under the BIST mode, the DES parallel outputs on RxOUT[31:0] are multiplexed to represent BIST status indicators. The pass/fail status of the BIST is represented by a Pass flag along with an Error counter. The Pass flag output is designated on DES RxOUT0 for Channel 0, and RxOUT8 for Channel 1. The DES's PLL must first be locked to ensure the Pass status is valid. The output Pass status pin will stay LOW and then transition to High once  $44 \times 10^6$  symbols are achieved across each of the respective transmission links. The total time duration of the test is defined by the following:  $44 \times 10^6 \times tCIP$ . After the Pass output flags reach a HIGH state, it will not drop to LOW even if subsequent bit errors occurred after the BIST duration period. Errors will be reported if the input test pattern comparison does not match. If an error (miss-compare) occurs, the status bit is latched on RxOUT[7:1] for Channel 0, and RxOUT[15:9] for Channel 1; reflecting the number of errors detected. Whenever a data bit contains an error, the Error counter bit output for that corresponding channel goes HIGH. Each counter for the serial link utilizes a 7-bit counter to store the number of errors detected (0 to 127 max).

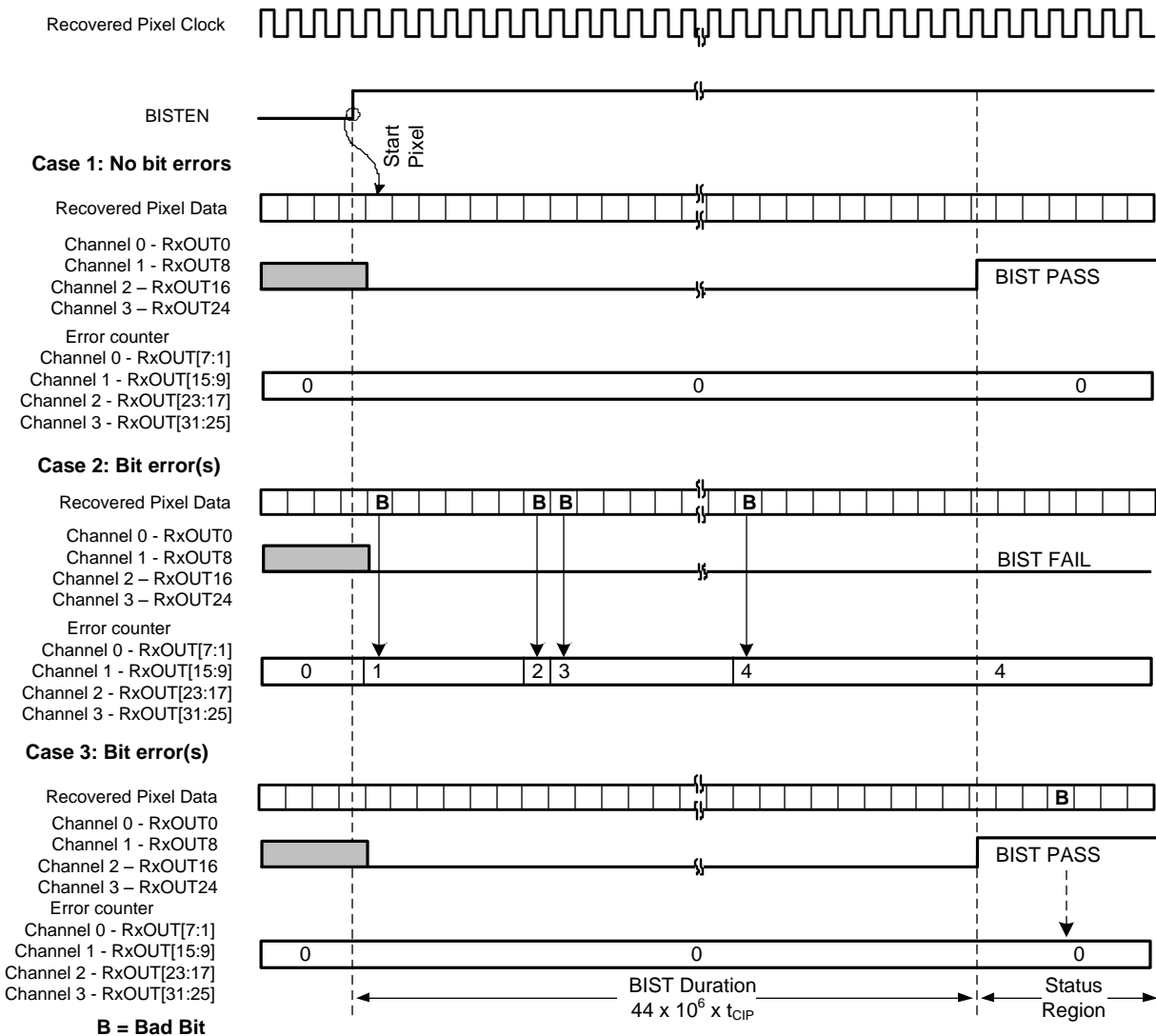

Figure 19. BIST Diagram for Different Bit Error Cases

## TYPICAL APPLICATION CONNECTION

Figure 20 shows a typical application of the DS92LV3241 Serializer (SER). The differential outputs utilize 100nF coupling capacitors to the serial lines. Bypass capacitors are placed near the power supply pins. A system GPO (General Purpose Output) controls the PDB and BISTEN pins. In this application the R\_FB (SER) pin is tied Low to latch data on the falling edge of the TxCLKIN. In this application the link is short, therefore the VSEL pin is tied LOW for the standard output swing level. The Pre-emphasis input utilizes a resistor to ground to set the amount of pre-emphasis desired by the application.

Configuration pins for the typical application are shown for SER:

- PDB – Power Down Control Input – Connect to host or tie HIGH (always ON)
- BISTEN – Mode Input - tie LOW if BIST mode is not used, or connect to host
- VSEL – tie LOW for normal VOD magnitude (application dependant)
- MODE – For clock rates between 20 MHz and 50 MHz tie LOW, for 40 MHz to 85 MHz tie HIGH
- PRE – Leave open if not required (have a R pad option on PCB)
- RSVD1 & RSVD2 – tie LOW

There are eight power pins for the device. These may be bussed together on a common 3.3V plane (3.3V LVCMOS I/O interface). If 1.8V input swing level for parallel data and control pins are required, connect the IOVDD pin to 1.8V. At a minimum, eight 0.1µF capacitors should be used for local bypassing.

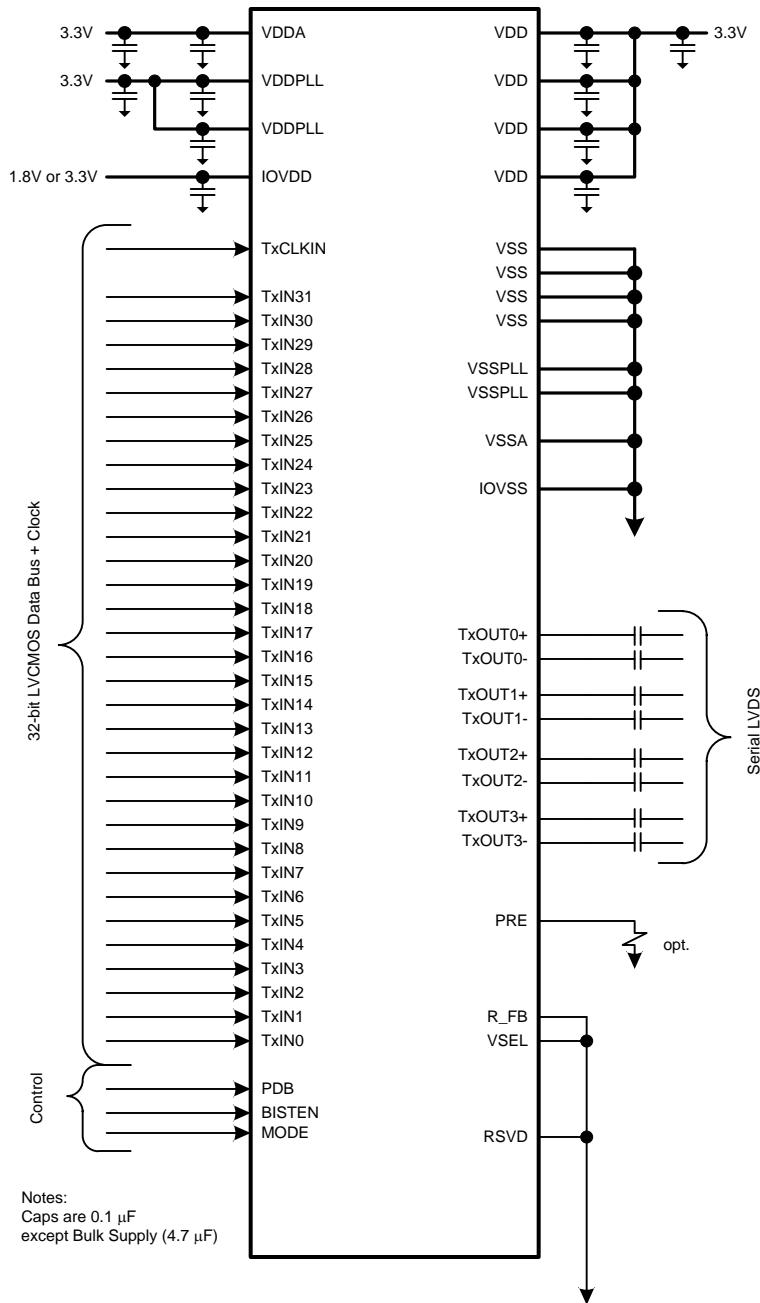

Figure 20. DS92LV3241 Typical Connection Diagram

Figure 21 shows a typical application of the DS92LV3242 Deserializer (DES). The differential inputs utilize 100nF coupling capacitors in the serial lines. Bypass capacitors are placed near the power supply pins. A system GPO (General Purpose Output) controls the PDB pin. In this application the R\_FB (DES) pin is tied Low to strobe the data on the falling edge of the RxCLKOUT. The REN signal is not used and is tied High also.

Configuration pins for the typical application are shown for DES:

- PDB – Power Down Control Input – Connect to host or tie HIGH
- REN – tie HIGH if not used (used to MUX two DES to one target device)
- RSVD – tie LOW

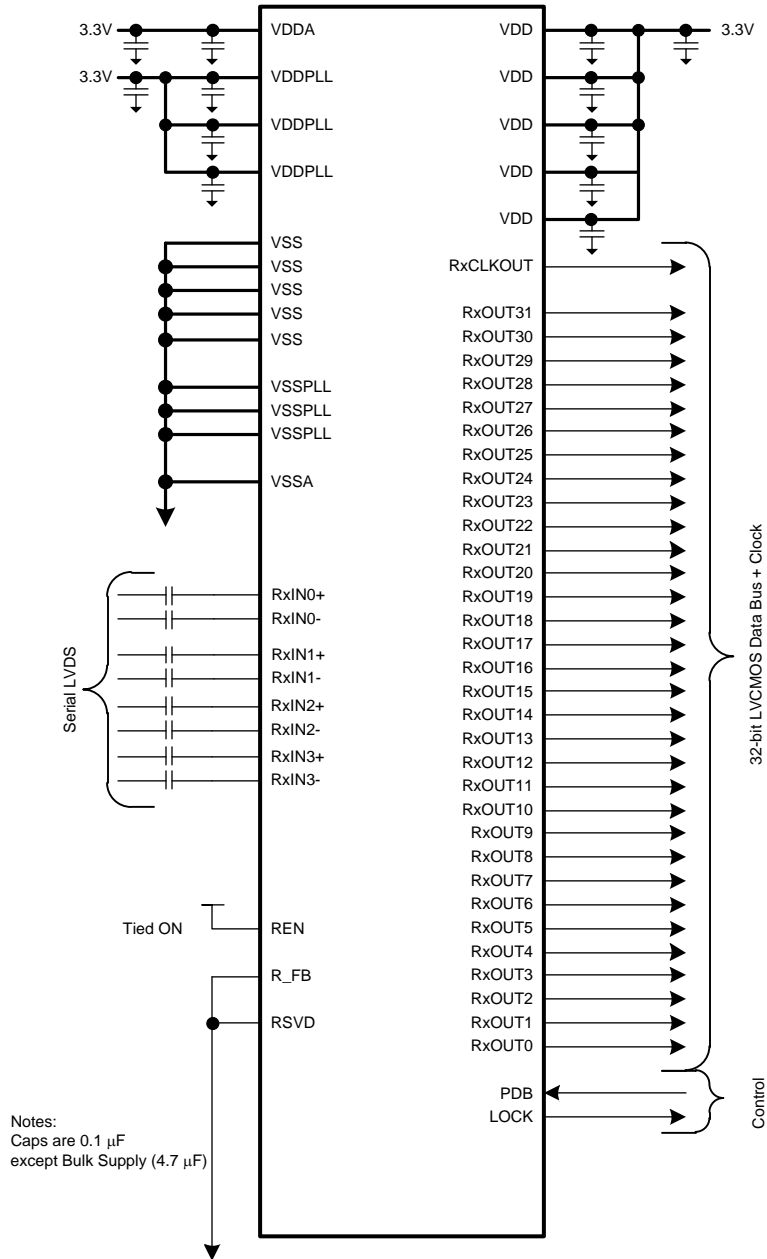

Figure 21. DS92LV3242 Typical Connection Diagram

## Applications Information

### TRANSMISSION MEDIA

The SER and DES are used in AC-coupled point-to-point configurations, through a PCB trace, or through twisted pair cables. Interconnect for LVDS typically has a differential impedance of 100 Ohms. Use cables and connectors that have matched differential impedance to minimize impedance discontinuities. In most applications that involve cables, the transmission distance will be determined on data rates involved, acceptable bit error rate and transmission medium.

### PCB LAYOUT AND POWER SYSTEM CONSIDERATIONS

Circuit board layout and stack-up for the LVDS SER/DES devices should be designed to provide low-noise power feed to the device. Good layout practice will also separate high frequency or high-level inputs and outputs to minimize unwanted stray noise pickup, feedback and interference. Power system performance may be greatly improved by using thin dielectrics (2 to 4 mils) for power / ground sandwiches. This arrangement provides plane capacitance for the PCB power system with low-inductance parasitics, which has proven especially effective at high frequencies, and makes the value and placement of external bypass capacitors less critical. External bypass capacitors should include both RF ceramic and tantalum electrolytic types. RF capacitors may use values in the range of 0.01 uF to 0.1 uF. Tantalum capacitors may be in the 2.2 uF to 10 uF range. Voltage rating of the tantalum capacitors should be at least 5X the power supply voltage being used.

Surface mount capacitors are recommended due to their smaller parasitics. When using multiple capacitors per supply pin, locate the smaller value closer to the pin. A large bulk capacitor is recommended at the point of power entry. This is typically in the 50uF to 100uF range and will smooth low frequency switching noise. It is recommended to connect power and ground pins directly to the power and ground planes with bypass capacitors connected to the plane with vias on both ends of the capacitor. Connecting power or ground pins to an external bypass capacitor will increase the inductance of the path.

A small body size X7R chip capacitor, such as 0603, is recommended for external bypass. Its small body size reduces the parasitic inductance of the capacitor. The user must pay attention to the resonance frequency of these external bypass capacitors, usually in the range of 20-30 MHz range. To provide effective bypassing, multiple capacitors are often used to achieve low impedance between the supply rails over the frequency of interest. At high frequency, it is also a common practice to use two vias from power and ground pins to the planes, reducing the impedance at high frequency.

Some devices provide separate power and ground pins for different portions of the circuit. This is done to isolate switching noise effects between different sections of the circuit. Separate planes on the PCB are typically not required. Pin Description tables typically provide guidance on which circuit blocks are connected to which power pin pairs. In some cases, an external filter may be used to provide clean power to sensitive circuits such as PLLs.

Use at least a four layer board with a power and ground plane. Locate LVCMOS signals away from the LVDS lines to prevent coupling from the LVCMOS lines to the LVDS lines. Closely-coupled differential lines of 100 Ohms are typically recommended for LVDS interconnect. The closely coupled lines help to ensure that coupled noise will appear as common mode and thus is rejected by the receivers. The tightly coupled lines will also radiate less.

### PLUG AND GO

The Serializer and Deserializer devices support hot plugging of the serial interconnect. The automatic receiver lock to random data “plug & go” capability allows the DS92LV3242 to obtain lock to the active data stream during a live insertion event.

### LVDS INTERCONNECT GUIDELINES

For full details, see the *Channel-Link PCB and Interconnect Design-In Guidelines* (literature number [SNLA008](#)) and the *Transmission Line RAPIDESIGNER Operation and Applications Guide* (literature number [SNLA035](#)).

- Use 100 Ohm coupled differential pairs
- Use the S/2S/3S rule in spacings
  - S = space between the pair
  - 2S = space between pairs

- 3S = space to LVCMOS signal
- Minimize the number of vias
- Use differential connectors when operating above 500 Mbps line speed
- Maintain balance of the traces
- Minimize skew within the pair
- Terminate as close to the TX outputs and RX inputs as possible

Additional general guidance can be found in the *LVDS Owner's Manual* (literature number [SNLA187](#)), which is available in PDF format from the TI [LVDS & CML Solutions](#) web site.

### Typical Performance Characteristics

The waveforms below illustrate the typical performance of the DS92LV3241. The SER was given a PCLK and configured as described below each picture. In all of the pictures the SER was configured with BISTEN pin set to logic HIGH. Each waveform was taken by using a high impedance low capacitance differential probe to probe across a 100 ohm differential termination resistor within one inch of TxOUT0+/-.

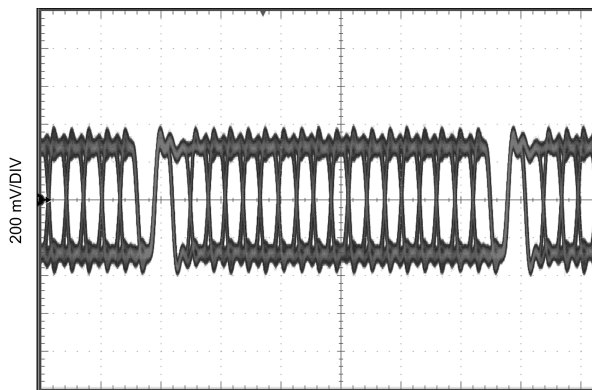

Figure 22. Serial Output Quad Mode, 85 MHz, VSEL = H, No Pre-Emphasis

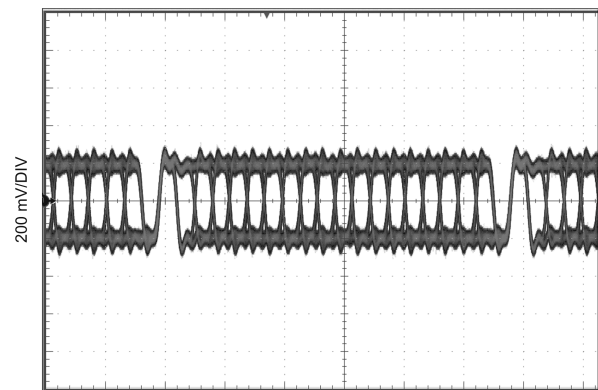

Figure 23. Serial Output Quad Mode, 85 MHz, VSEL = L, No Pre-Emphasis

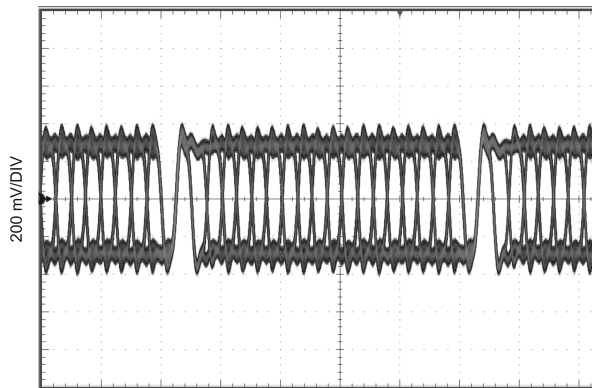

Figure 24. Serial Output Dual Mode, 50 MHz, VSEL = H, No Pre-Emphasis

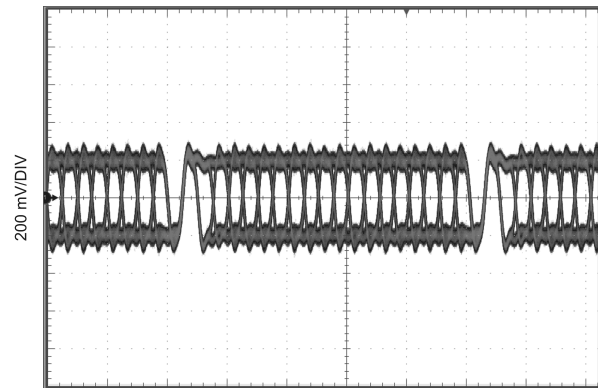

Figure 25. Serial Output Dual Mode, 50 MHz, VSEL = L, No Pre-Emphasis

---

## REVISION HISTORY

Changes from Revision C (April 2013) to Revision D	Page
• Changed layout of National Data Sheet to TI format .....	<a href="#">24</a>

---

## PACKAGING INFORMATION

Orderable Device	Status (1)	Package Type	Package Drawing	Pins	Package Qty	Eco Plan (2)	Lead/Ball Finish (6)	MSL Peak Temp (3)	Op Temp (°C)	Device Marking (4/5)	Samples
DS92LV3241TVS/NOPB	ACTIVE	TQFP	PAG	64	160	Green (RoHS & no Sb/Br)	CU SN	Level-3-260C-168 HR	-40 to 85	DS92LV3241 TVS	<a href="#">Samples</a>
DS92LV3241TVSX/NOPB	ACTIVE	TQFP	PAG	64	1000	Green (RoHS & no Sb/Br)	CU SN	Level-3-260C-168 HR	-40 to 85	DS92LV3241 TVS	<a href="#">Samples</a>
DS92LV3242TVS/NOPB	ACTIVE	TQFP	PAG	64	160	Green (RoHS & no Sb/Br)	CU SN	Level-3-260C-168 HR	-40 to 85	DS92LV3242 TVS	<a href="#">Samples</a>
DS92LV3242TVSX/NOPB	ACTIVE	TQFP	PAG	64	1000	Green (RoHS & no Sb/Br)	CU SN	Level-3-260C-168 HR	-40 to 85	DS92LV3242 TVS	<a href="#">Samples</a>

(1) The marketing status values are defined as follows:

**ACTIVE:** Product device recommended for new designs.

**LIFEBUY:** TI has announced that the device will be discontinued, and a lifetime-buy period is in effect.

**NRND:** Not recommended for new designs. Device is in production to support existing customers, but TI does not recommend using this part in a new design.

**PREVIEW:** Device has been announced but is not in production. Samples may or may not be available.

**OBSELETE:** TI has discontinued the production of the device.

(2) Eco Plan - The planned eco-friendly classification: Pb-Free (RoHS), Pb-Free (RoHS Exempt), or Green (RoHS & no Sb/Br) - please check <http://www.ti.com/productcontent> for the latest availability information and additional product content details.

**TBD:** The Pb-Free/Green conversion plan has not been defined.

**Pb-Free (RoHS):** TI's terms "Lead-Free" or "Pb-Free" mean semiconductor products that are compatible with the current RoHS requirements for all 6 substances, including the requirement that lead not exceed 0.1% by weight in homogeneous materials. Where designed to be soldered at high temperatures, TI Pb-Free products are suitable for use in specified lead-free processes.

**Pb-Free (RoHS Exempt):** This component has a RoHS exemption for either 1) lead-based flip-chip solder bumps used between the die and package, or 2) lead-based die adhesive used between the die and leadframe. The component is otherwise considered Pb-Free (RoHS compatible) as defined above.

**Green (RoHS & no Sb/Br):** TI defines "Green" to mean Pb-Free (RoHS compatible), and free of Bromine (Br) and Antimony (Sb) based flame retardants (Br or Sb do not exceed 0.1% by weight in homogeneous material)

(3) MSL, Peak Temp. - The Moisture Sensitivity Level rating according to the JEDEC industry standard classifications, and peak solder temperature.

(4) There may be additional marking, which relates to the logo, the lot trace code information, or the environmental category on the device.

(5) Multiple Device Markings will be inside parentheses. Only one Device Marking contained in parentheses and separated by a "~" will appear on a device. If a line is indented then it is a continuation of the previous line and the two combined represent the entire Device Marking for that device.

(6) Lead/Ball Finish - Orderable Devices may have multiple material finish options. Finish options are separated by a vertical ruled line. Lead/Ball Finish values may wrap to two lines if the finish value exceeds the maximum column width.

**Important Information and Disclaimer:**The information provided on this page represents TI's knowledge and belief as of the date that it is provided. TI bases its knowledge and belief on information provided by third parties, and makes no representation or warranty as to the accuracy of such information. Efforts are underway to better integrate information from third parties. TI has taken and continues to take reasonable steps to provide representative and accurate information but may not have conducted destructive testing or chemical analysis on incoming materials and chemicals. TI and TI suppliers consider certain information to be proprietary, and thus CAS numbers and other limited information may not be available for release.

In no event shall TI's liability arising out of such information exceed the total purchase price of the TI part(s) at issue in this document sold by TI to Customer on an annual basis.

**TAPE AND REEL INFORMATION**

**QUADRANT ASSIGNMENTS FOR PIN 1 ORIENTATION IN TAPE**

\*All dimensions are nominal

Device	Package Type	Package Drawing	Pins	SPQ	Reel Diameter (mm)	Reel Width W1 (mm)	A0 (mm)	B0 (mm)	K0 (mm)	P1 (mm)	W (mm)	Pin1 Quadrant
DS92LV3241TVSX/NOPB	TQFP	PAG	64	1000	330.0	24.4	13.0	13.0	1.45	16.0	24.0	Q2
DS92LV3242TVSX/NOPB	TQFP	PAG	64	1000	330.0	24.4	13.0	13.0	1.45	16.0	24.0	Q2

**TAPE AND REEL BOX DIMENSIONS**

\*All dimensions are nominal

Device	Package Type	Package Drawing	Pins	SPQ	Length (mm)	Width (mm)	Height (mm)
DS92LV3241TVSX/NOPB	TQFP	PAG	64	1000	367.0	367.0	45.0
DS92LV3242TVSX/NOPB	TQFP	PAG	64	1000	367.0	367.0	45.0

PAG (S-PQFP-G64)

PLASTIC QUAD FLATPACK

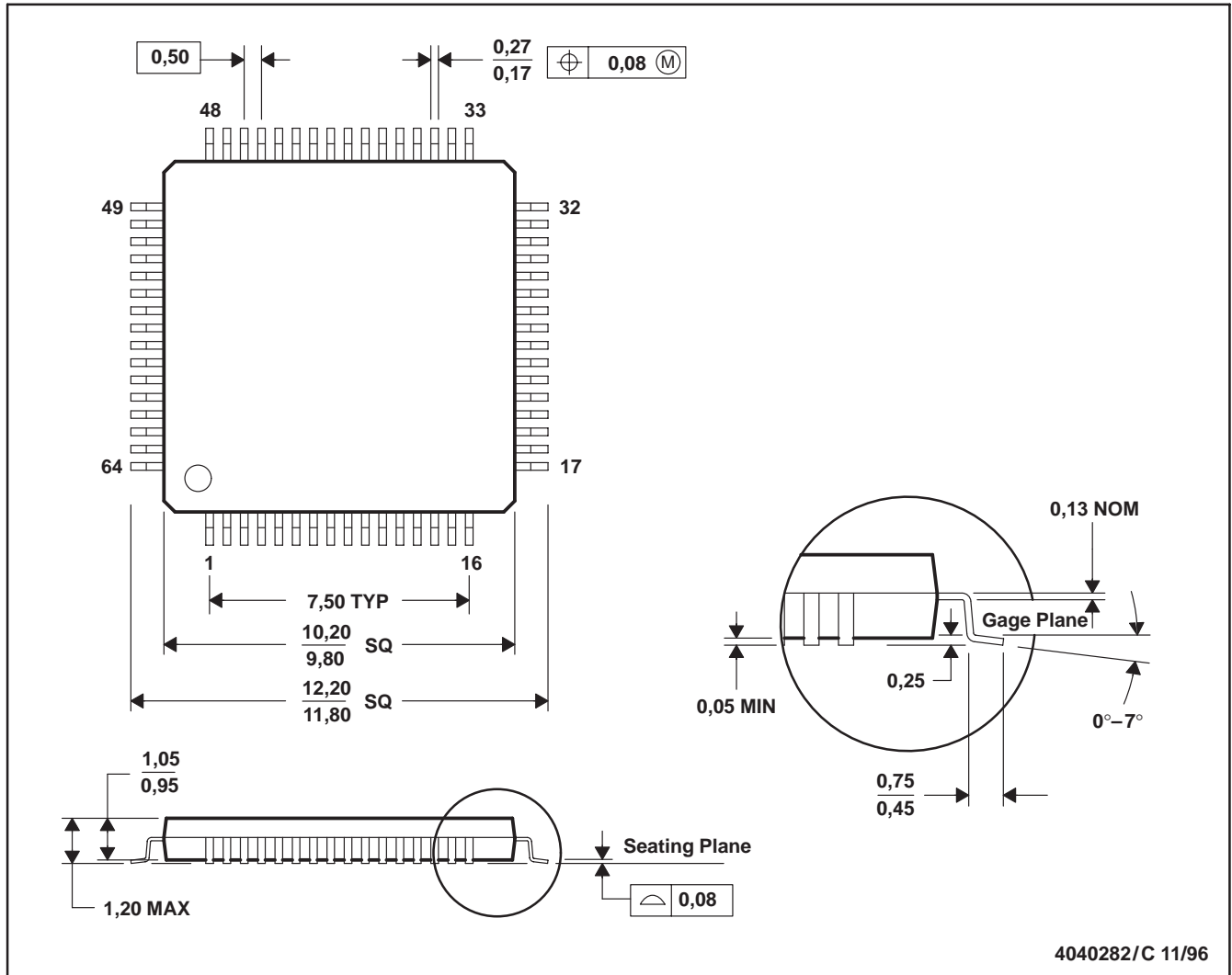

- NOTES: A. All linear dimensions are in millimeters.  
 B. This drawing is subject to change without notice.  
 C. Falls within JEDEC MS-026

## IMPORTANT NOTICE

Texas Instruments Incorporated and its subsidiaries (TI) reserve the right to make corrections, enhancements, improvements and other changes to its semiconductor products and services per JESD46, latest issue, and to discontinue any product or service per JESD48, latest issue. Buyers should obtain the latest relevant information before placing orders and should verify that such information is current and complete. All semiconductor products (also referred to herein as "components") are sold subject to TI's terms and conditions of sale supplied at the time of order acknowledgment.

TI warrants performance of its components to the specifications applicable at the time of sale, in accordance with the warranty in TI's terms and conditions of sale of semiconductor products. Testing and other quality control techniques are used to the extent TI deems necessary to support this warranty. Except where mandated by applicable law, testing of all parameters of each component is not necessarily performed.

TI assumes no liability for applications assistance or the design of Buyers' products. Buyers are responsible for their products and applications using TI components. To minimize the risks associated with Buyers' products and applications, Buyers should provide adequate design and operating safeguards.

TI does not warrant or represent that any license, either express or implied, is granted under any patent right, copyright, mask work right, or other intellectual property right relating to any combination, machine, or process in which TI components or services are used. Information published by TI regarding third-party products or services does not constitute a license to use such products or services or a warranty or endorsement thereof. Use of such information may require a license from a third party under the patents or other intellectual property of the third party, or a license from TI under the patents or other intellectual property of TI.

Reproduction of significant portions of TI information in TI data books or data sheets is permissible only if reproduction is without alteration and is accompanied by all associated warranties, conditions, limitations, and notices. TI is not responsible or liable for such altered documentation. Information of third parties may be subject to additional restrictions.

Resale of TI components or services with statements different from or beyond the parameters stated by TI for that component or service voids all express and any implied warranties for the associated TI component or service and is an unfair and deceptive business practice. TI is not responsible or liable for any such statements.

Buyer acknowledges and agrees that it is solely responsible for compliance with all legal, regulatory and safety-related requirements concerning its products, and any use of TI components in its applications, notwithstanding any applications-related information or support that may be provided by TI. Buyer represents and agrees that it has all the necessary expertise to create and implement safeguards which anticipate dangerous consequences of failures, monitor failures and their consequences, lessen the likelihood of failures that might cause harm and take appropriate remedial actions. Buyer will fully indemnify TI and its representatives against any damages arising out of the use of any TI components in safety-critical applications.

In some cases, TI components may be promoted specifically to facilitate safety-related applications. With such components, TI's goal is to help enable customers to design and create their own end-product solutions that meet applicable functional safety standards and requirements. Nonetheless, such components are subject to these terms.

No TI components are authorized for use in FDA Class III (or similar life-critical medical equipment) unless authorized officers of the parties have executed a special agreement specifically governing such use.

Only those TI components which TI has specifically designated as military grade or "enhanced plastic" are designed and intended for use in military/aerospace applications or environments. Buyer acknowledges and agrees that any military or aerospace use of TI components which have **not** been so designated is solely at the Buyer's risk, and that Buyer is solely responsible for compliance with all legal and regulatory requirements in connection with such use.

TI has specifically designated certain components as meeting ISO/TS16949 requirements, mainly for automotive use. In any case of use of non-designated products, TI will not be responsible for any failure to meet ISO/TS16949.

### Products

Audio	<a href="http://www.ti.com/audio">www.ti.com/audio</a>
Amplifiers	<a href="http://amplifier.ti.com">amplifier.ti.com</a>
Data Converters	<a href="http://dataconverter.ti.com">dataconverter.ti.com</a>
DLP® Products	<a href="http://www.dlp.com">www.dlp.com</a>
DSP	<a href="http://dsp.ti.com">dsp.ti.com</a>
Clocks and Timers	<a href="http://www.ti.com/clocks">www.ti.com/clocks</a>
Interface	<a href="http://interface.ti.com">interface.ti.com</a>
Logic	<a href="http://logic.ti.com">logic.ti.com</a>
Power Mgmt	<a href="http://power.ti.com">power.ti.com</a>
Microcontrollers	<a href="http://microcontroller.ti.com">microcontroller.ti.com</a>
RFID	<a href="http://www.ti-rfid.com">www.ti-rfid.com</a>
OMAP Applications Processors	<a href="http://www.ti.com/omap">www.ti.com/omap</a>
Wireless Connectivity	<a href="http://www.ti.com/wirelessconnectivity">www.ti.com/wirelessconnectivity</a>

### Applications

Automotive and Transportation	<a href="http://www.ti.com/automotive">www.ti.com/automotive</a>
Communications and Telecom	<a href="http://www.ti.com/communications">www.ti.com/communications</a>
Computers and Peripherals	<a href="http://www.ti.com/computers">www.ti.com/computers</a>
Consumer Electronics	<a href="http://www.ti.com/consumer-apps">www.ti.com/consumer-apps</a>
Energy and Lighting	<a href="http://www.ti.com/energy">www.ti.com/energy</a>
Industrial	<a href="http://www.ti.com/industrial">www.ti.com/industrial</a>
Medical	<a href="http://www.ti.com/medical">www.ti.com/medical</a>
Security	<a href="http://www.ti.com/security">www.ti.com/security</a>
Space, Avionics and Defense	<a href="http://www.ti.com/space-avionics-defense">www.ti.com/space-avionics-defense</a>
Video and Imaging	<a href="http://www.ti.com/video">www.ti.com/video</a>

### TI E2E Community

[e2e.ti.com](http://e2e.ti.com)

## Looking for pricing, stock, or lifecycle information?

Click below to explore more details on WIN SOURCE:

 [View DS92LV3242TVS/NOPB on WIN SOURCE](#)

 [Texas Instruments](#) Information

## Optimize Your Supply Chain with WIN SOURCE Solutions

-  Global Sourcing Solution
-  Obsolete Management
-  Cost Control Management
-  Shortage Management
-  Alternative Solution
-  Excess Inventory Management