



**THE DATASHEET OF
CD54AC374F3A**



CDx4AC374, CDx4ACT374, CD74AC534 Octal D-Type Flip-Flops, 3-State Positive-Edge Triggered

1 Features

- SCR-Latch-up-resistant CMOS process and circuit design
- Speed of bipolar FAST^{*}/AS/S with significantly reduced power consumption
- Balanced propagation delays
- AC types feature 1.5V to 5.5V operation and balanced noise immunity at 30% of the supply
- ± 24mA output drive current
 - Fanout to 15 FAST^{*} ICs
 - Drives 50ohm transmission lines

2 Description

The eight flip-flops of the 'AC374 devices are D-type edge-triggered flip-flops. On the positive transition of the clock (CLK) input, the Q outputs are set to the logic levels set up at the data (D) inputs.

Device Information

PART NUMBER	PACKAGE ⁽¹⁾	PACKAGE SIZE ⁽²⁾	BODY SIZE ⁽³⁾
CDx4AC/ACT374, CD74AC534	DW (SOIC, 20)	12.80mm × 10.3mm	12.80mm × 7.50mm
	N (PDIP, 20)	24.33mm × 9.4mm	24.33mm × 6.35mm

- (1) For more information, see [Section 10](#).
- (2) The package size (length × width) is a nominal value and includes pins, where applicable.
- (3) The body size (length × width) is a nominal value and does not include pins.

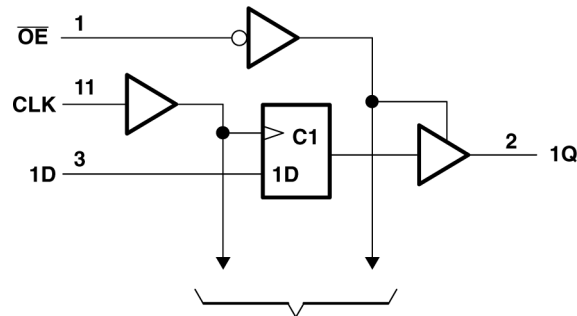

To Seven Other Channels
Logic Diagram (Positive Logic)

^{*} FAST is a Registered Trademark of Fairchild Semiconductor Corp.



Table of Contents

1 Features	1	6.2 Functional Block Diagram.....	11
2 Description	1	6.3 Device Functional Modes.....	11
3 Pin Configuration and Functions	3	7 Application and Implementation	12
4 Specifications	4	7.1 Typical Application.....	12
4.1 Absolute Maximum Ratings.....	4	7.2 Power Supply Recommendations.....	12
4.2 ESD Ratings.....	4	7.3 Layout.....	13
4.3 Recommended Operating Conditions:.....	4	8 Device and Documentation Support	14
4.4 Thermal Information.....	4	8.1 Documentation Support (Analog).....	14
4.5 Electrical Characteristics: AC Series.....	5	8.2 Receiving Notification of Documentation Updates....	14
4.6 Electrical Characteristics: ACT Series.....	5	8.3 Support Resources.....	14
4.7 Prerequisite for Switching: AC Series.....	6	8.4 Trademarks.....	14
4.8 Switching Characteristics: AC Series.....	7	8.5 Electrostatic Discharge Caution.....	14
4.9 Prerequisite for Switching: ACT Series.....	7	8.6 Glossary.....	14
4.10 Switching Characteristics: ACT Series.....	7	9 Revision History	14
5 Parameter Measurement Information	9	10 Mechanical, Packaging, and Orderable Information	15
6 Detailed Description	11		
6.1 Overview.....	11		

3 Pin Configuration and Functions

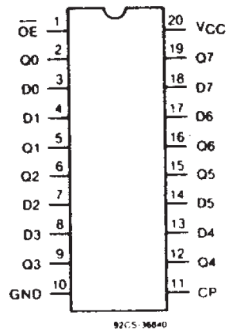

Figure 3-1. CDx4AC/ACT374, CD74AC534

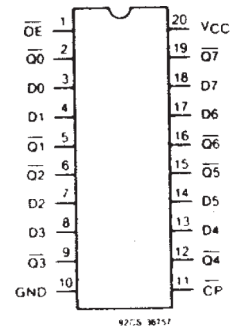

Figure 3-2. CDx4AC/ACT374, CD74AC534

Table 3-1. Pin Functions

PIN		TYPE	DESCRIPTION
NAME	NO.		
OE	1	I	Enable pin
1Q	2	O	Output 1
1D	3	I	Input 1
2D	4	I	Input 2
2Q	5	O	Output 2
3Q	6	O	Output 3
3D	7	I	Input 3
4D	8	I	Input 4
4Q	9	O	Output 4
GND	10	–	Ground pin
CLK	11	I	Clock pin
5Q	12	O	Output 5
5D	13	I	Input 5
6D	14	I	Input 6
6Q	15	O	Output 6
7Q	16	O	Output 7
7D	17	I	Input 7
8D	18	I	Input 8
8Q	19	O	Output 8
V _{CC}	20	–	Power pin

4 Specifications

4.1 Absolute Maximum Ratings

over operating free-air temperature range (unless otherwise noted)⁽¹⁾

		MIN	MAX	UNIT
V _{CC}	Supply-voltage	-0.5	6	V
I _{IK}	Input diode current	(V _I < -0.5 V or V _I > V _{CC} ± 0.5 V)		±20 mA
I _{OK}	Output diode current	V _O < -0.5 V or V _O > V _{CC} + 0.5 V		±50 mA
I _O	Output source or sink current per output pin	(V _O > -0.5 V or V _O < V _{CC} + 0.5 V)		±50 mA
DC V _{CC} or ground current (I _{CC} or I _{GND})				±100 mA ⁽²⁾
T _{stg}	Storage temperature	-65	+150	°C

- (1) Operation outside the Absolute Maximum Ratings may cause permanent device damage. Absolute Maximum Ratings do not imply functional operation of the device at these or any other conditions beyond those listed under Recommended Operating Conditions. If used outside the Recommended Operating Conditions but within the Absolute Maximum Ratings, the device may not be fully functional, and this may affect device reliability, functionality, performance, and shorten the device lifetime.
- (2) For up to 4 outputs per device; add ± 25 mA for each additional output.

4.2 ESD Ratings

			VALUE	UNIT
V _(ESD)	Electrostatic discharge	Human body model (HBM), per ANSI/ESDA/JEDEC JS-0011	±2000	V

4.3 Recommended Operating Conditions:

For maximum reliability, normal operating conditions should be selected so that operation is always within the following ranges:

CHARACTERISTIC	MIN	MAX	UNIT
V _{CC} ⁽¹⁾ Supply-Voltage Range: (For T _A = Full Package-Temperature Range)			
AC Types	1.5	5.5	V
ACT Types	4.5	5.5	V
V _I , V _O Input or Output Voltage	0	V _{CC}	V
T _A Operating Temperature	-55	+125	°C
dt/dv Input Rise and Fall Slew Rate			
at 1.5 V to 3 V (AC Types)	0	50	ns/V
at 3.6 V to 5.5 V (AC Types)	0	20	ns/V
at 4.5 V to 5.5 V (ACT Types)	0	10	ns/V

- (1) Unless otherwise specified, all voltages are referenced to ground.

4.4 Thermal Information

THERMAL METRIC ⁽¹⁾	CDx4AC/ACT374, CD74AC534		UNIT
	DW (SOIC)	N (PDIP)	
	20 PINS	20 PINS	
R _{θJA} Junction-to-ambient thermal resistance	101.2	50	°C/W

- (1) For more information about traditional and new thermal metrics, see the [Semiconductor and IC Package Thermal Metrics](#) application report.

4.5 Electrical Characteristics: AC Series

CHARACTERISTICS		TEST CONDITIONS		V _{CC} (V)	AMBIENT TEMPERATURE (T _A) - °C						UNIT	
					+25		-40 to +85		-55 to +125			
					MIN	MAX	MIN	MAX	MIN	MAX		
V _{IH}	High-Level Input Voltage			1.5	1.2	—	1.2	—	1.2	—	V	
				3	2.1	—	2.1	—	2.1	—		
				5.5	3.85	—	3.85	—	3.85	—		
V _{IL}	Low-Level Input Voltage			1.5	—	0.3	—	0.3	—	0.3	V	
				3	—	0.9	—	0.9	—	0.9		
				5.5	—	1.65	—	1.65	—	1.65		
V _{OH}	High-Level Output Voltage	V _{IH} or V _{IL} ⁽¹⁾ , ⁽²⁾		-0.05	1.5	1.4	—	1.4	—	1.4	—	V
				-0.05	3	2.9	—	2.9	—	2.9	—	
				-0.05	4.5	4.4	—	4.4	—	4.4	—	
				-4	3	2.58	—	2.48	—	2.4	—	
				-24	4.5	3.94	—	3.8	—	3.7	—	
				-75	5.5	—	—	3.85	—	—	—	
V _{OH}	Low-Level Output Voltage	V _{IH} or V _{IL} ⁽¹⁾ , ⁽²⁾		0.05	1.5	—	0.1	—	0.1	—	0.1	V
				0.05	3	—	0.1	—	0.1	—	0.1	
				0.05	4.5	—	0.1	—	0.1	—	0.1	
				12	3	—	0.36	—	0.44	—	0.5	
				24	4.5	—	0.36	—	0.44	—	0.5	
				75	5.5	—	—	—	1.65	—	—	
				50	5.5	—	—	—	—	—	1.65	
I _I	Input Leakage Current	V _{CC} or GND		5.5	—	±0.1	—	±1	—	±1	μA	
I _{OZ}	3-State Leakage Current	V _{IH} or V _{IL} V _O = V _{CC} or GND		5.5	—	±0.5	—	±5	—	±10	μA	
I _{CC}	Quiescent Supply Current, MSI	V _{CC} or GND	0	5.5	—	8	—	80	—	160	μA	

- (1) Test one output at a time for a 1-second maximum duration. Measurement is made by forcing current and measuring voltage to minimize power dissipation.
(2) Test verifies a minimum 50-ohm transmission-line-drive capability at +85°C, 75 ohms at +125°C.

4.6 Electrical Characteristics: ACT Series

CHARACTERISTICS		TEST CONDITIONS		V _{CC} (V)	AMBIENT TEMPERATURE (T _A) - °C						UNIT	
					+25		-40 to +85		-55 to +125			
					MIN	MAX	MIN	MAX	MIN	MAX		
V _{IH}	High-Level Input Voltage			4.5 to 5.5	2	—	2	—	2	—	V	
V _{IL}	Low-Level Input Voltage			4.5 to 5.5	—	0.8	—	0.8	—	0.8	V	
V _{OH}	High-Level Output Voltage	V _{IH} or V _{IL} ⁽¹⁾ , ⁽²⁾		-0.05	4.5	4.4	—	4.4	—	4.4	—	V
				-24	4.5	3.94	—	3.8	—	3.7	—	
				-75	5.5	—	—	3.85	—	—	—	
				-50	5.5	—	—	—	—	3.85	—	

CHARACTERISTICS	TEST CONDITIONS		V _{CC} (V)	AMBIENT TEMPERATURE (T _A) - °C						UNIT
				+25		-40 to +85		-55 to +125		
	V _I (V)	I _O (mA)		MIN	MAX	MIN	MAX	MIN	MAX	
V _{OL} Low-Level Output Voltage	V _{IH} or V _{IL} (1), (2)	0.05	4.5	—	0.1	—	0.1	—	0.1	V
		24	4.5	—	0.36	—	0.44	—	0.5	
		75	5.5	—	—	—	1.65	—	—	
		50	5.5	—	—	—	—	—	1.65	
I _I Input Leakage Current	V _{CC} or GND		5.5	—	±0.1	—	±1	—	±1	µA
I _{oZ} 3-State Leakage Current	V _{IH} or V _{IL} V _O = V _{CC} or GND		5.5	—	±0.5	—	±5	—	±10	µA
I _{CC} Quiescent Supply Current, MSI	V _{CC} or GND	0	5.5	—	8	—	80	—	160	µA
ΔI _{CC} Additional Quiescent Supply Current per Input Pin TTL Inputs High 1 Unit Load	V _{CC} -2.1		4.5 to 5.5	—	2.4	—	2.8	—	3	mA

- (1) Test one output at a time for a 1-second maximum duration. Measurement is made by forcing current and measuring voltage to minimize power dissipation.
 (2) Test verifies a minimum 50-ohm transmission-line-drive capability at +85°C. 75 ohms at + 125°C.

Act Input Loading Table

INPUT	UNIT LOADS ⁽²⁾
D, \overline{OE}	0.7
CP	1.17

4.7 Prerequisite for Switching: AC Series

CHARACTERISTICS		V _{CC} (V)	AMBIENT TEMPERATURE (T _A) - °C				UNIT
			-40 to +85		-55 to +125		
			MIN	MAX	MIN	MAX	
t _w	Clock Pulse Width	1.5	44	—	50	—	ns
		3.3 ⁽¹⁾	4.9	—	5.6	—	
		5 ⁽²⁾	3.5	—	4	—	
t _{SU}	Setup Time Data to Clock	1.5	2	—	2	—	ns
		3.3	2	—	2	—	
		5	2	—	2	—	
t _H	Hold Time Data to Clock	1.5	2	—	2	—	ns
		3.3	2	—	2	—	
		5	2	—	2	—	
f _{MAX}	Maximum Clock Frequency	1.5	11	—	10	—	MHz
		3.3	101	—	89	—	
		5	143	—	125	—	

- (1) 3.3 V: min. is @ 3 V
 (2) 5 V: min. is @ 4.5 V

4.8 Switching Characteristics: AC Series

$t_r, t_f = 3 \text{ ns}, C_L = 50 \text{ pF}$

SYMBOL	CHARACTERISTICS	V _{CC} (V)	AMBIENT TEMPERATURE (T _A) - °C				UNIT
			-40 to +85		-55 to +125		
			MIN	MAX	MIN	MAX	
t _{PLH} , t _{PHL}	Propagation Delays: Clock to Q AC374	1.5	—	123	—	135	ns
		3.3 ⁽¹⁾	3.9	13.7	3.8	15.1	
		5 ⁽²⁾	2.8	9.8	2.7	10.8	
t _{PLH} , t _{PHL}	Clock to \bar{Q} AC534	1.5	—	128	—	141	ns
		3.3	4.1	14.4	4	15.8	
		5	2.9	10.3	2.8	11.3	
t _{PLH} , t _{PZH}	Output Enable to Q, \bar{Q}	1.5	—	165	—	181	ns
		3.3	5.6	19.8	5.5	21.8	
		5	3.7	13.2	3.6	14.5	
t _{PLZ} , t _{PHZ}	Output Disable to Q, \bar{Q}	1.5	—	165	—	181	ns
		3.3	4.7	16.5	4.5	18.1	
		5	3.7	13.2	3.6	14.5	
C _{PD} ⁽³⁾	Power Dissipation Capacitance	—	67 Typ.		67 Typ.		pF
V _{OHV}	Min. (Valley) V _{OH} During Switching of Other Outputs (Output Under Test Not Switching)	5	4 Typ. @ 25°C				V
	Max. (Peak) V _{OL} During Switching of Other Outputs (Output Under Test Not Switching)	5	1 Typ. @25°C				V
C _I	Input Capacitance	—	—	10	—	10	pF
C _O	3-State Output Capacitance	—	—	15	—	15	pF

- (1) 3.3V: min. is @ 3.6 V
(2) 5 V: min. is @ 5.5 V
(3) C_{PD} is used to determine the dynamic power consumption, per flip flop.

4.9 Prerequisite for Switching: ACT Series

SYMBOL	CHARACTERISTICS	V _{CC} (V)	AMBIENT TEMPERATURE (T _A) - °C				UNIT
			-40 to +85		-55 to +125		
			MIN	MAX	MIN	MAX	
t _W	Clock Pulse Width	5 ⁽¹⁾	3.9	—	4.5	—	ns
t _{SU}	Setup Time Data to Clock	5	2	—	2	—	ns
t _H	Hold Time Data to Clock	5	2.6	—	3	—	ns
f _{MAX}	Maximum Clock Frequency	5	125	—	110	—	MHz

- (1) 5 V: min. is @ 4.5 V

4.10 Switching Characteristics: ACT Series

over recommended operating free-air temperature range, ACT Series; $t_r, t_f = 3 \text{ ns}, C_L = 50 \text{ pF}$ (unless otherwise noted) (see [Load Circuit and Voltage Waveforms](#))

SYMBOL	CHARACTERISTICS	V _{CC} (V)	AMBIENT TEMPERATURE (T _A) - °C				UNIT
			-40 to +85		-55 to +125		
			MIN	MAX	MIN	MAX	
t _{PLH} , t _{PHL}	Propagation Delays: Clock to Q ACT374	5 ⁽¹⁾	2.9	10.2	2.8	11.2	ns
t _{PLH} , t _{PHL}	Clock to \bar{Q} ACT534	5	3	10.6	2.9	11.7	ns
t _{PLZ} , t _{PHZ} , t _{PZL} , t _{PZH}	Output Enable and Disable to Q ACT374	5	3.7	13.2	3.6	14.5	ns

over recommended operating free-air temperature range, ACT Series; $t_r, t_f = 3$ ns, $C_L = 50$ pF (unless otherwise noted) (see [Load Circuit and Voltage Waveforms](#))

SYMBOL	CHARACTERISTICS	V_{CC} (V)	AMBIENT TEMPERATURE (T_A) - °C				UNIT
			-40 to +85		-55 to +125		
			MIN	MAX	MIN	MAX	
$t_{PLZ}, t_{PHZ}, t_{PZL}, t_{PZH}$	Output Enable and Disable to \bar{Q} ACT534	5	3.7	13.2	3.6	14.5	ns
C_{PD} ⁽²⁾	Power Dissipation Capacitance	—	67 Typ.		67 Typ.		pF
V_{OHV}	Min. (Valley) V_{OH} During Switching of Other Outputs (Output Under Test Not Switching)	5	4 Typ. @ 25°C				V
V_{OLP}	Max. (Peak) V_{OL} During Switching of Other Outputs (Output Under Test Not Switching)	5	1 Typ. @25°C				V
C_I	Input Capacitance	—	—	10	—	10	pF
C_O	3-State Output Capacitance	—	—	15	—	15	pF

(1) 5V: min. is @ 5.5 V

(2) C_{PD} is used to determine the dynamic power consumption, per flip flop.

5 Parameter Measurement Information

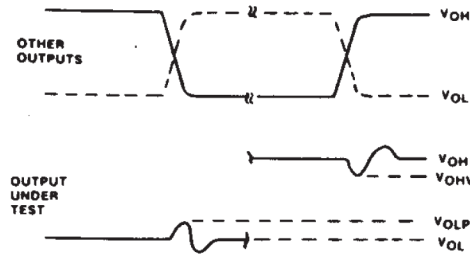

- A. $1 V_{OHV}$ AND V_{OLP} ARE MEASURED WITH RESPECT TO A GROUND REFERENCE NEAR THE OUTPUT UNDER TEST.
- B. INPUT PULSES HAVE THE FOLLOWING CHARACTERISTICS: $PRR \leq 1$ MHz, $t_f = 3$ ns, $t_r = 3$ ns, SKEW 1 ns.
- C. R.F. FIXTURE WITH 700-MHz DESIGN RULES REQUIRED. I_C SHOULD BE SOLDERED INTO TEST BOARD AND BYPASSED WITH $0.1 \mu F$ CAPACITOR. SCOPE AND PROBES REQUIRE 700-MHz BANDWIDTH
- D. 92CS-42406

Figure 5-1. Simultaneous Switching Transient Waveforms.

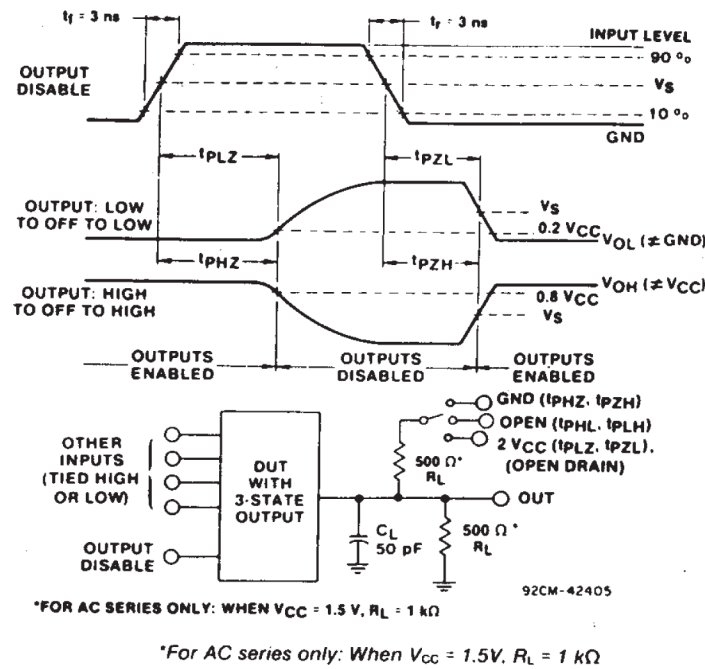

Figure 5-2. Three-state Propagation Delay Waveforms and Test Circuit.

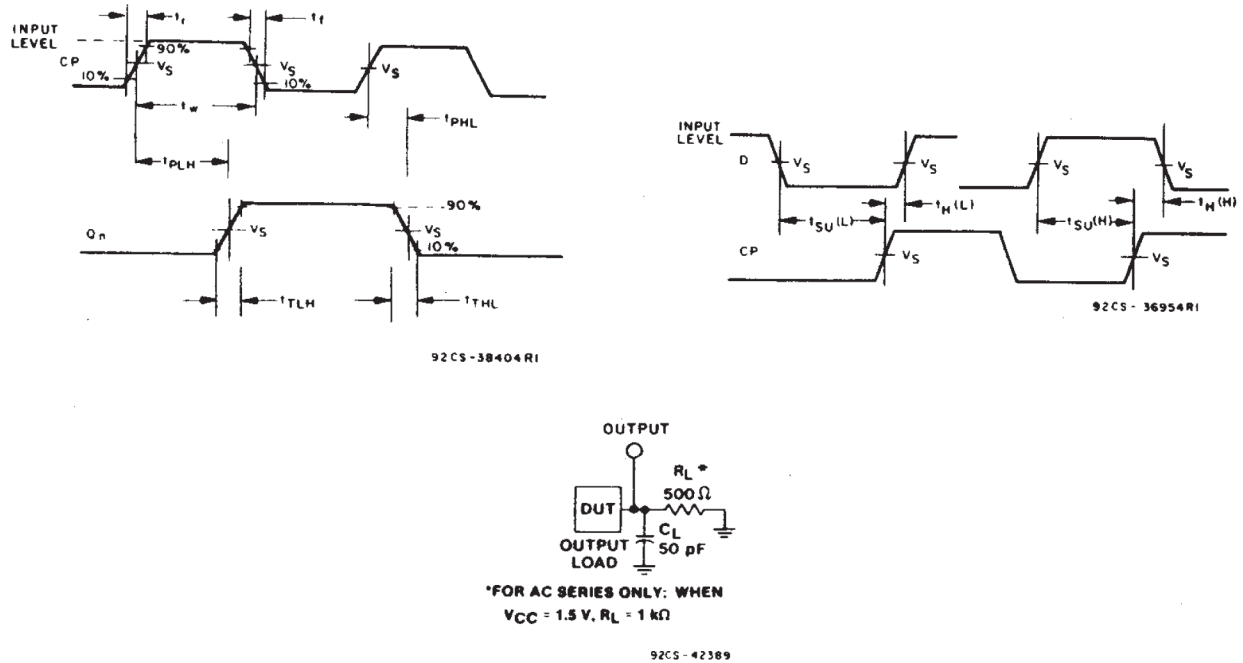

Figure 5-3. Propagation Delay Times and Test Circuit.

	CDx4AC	CDx4ACT
Input Level	V_{CC}	3 V
Input Switching Voltage, V_S	$0.5 V_{CC}$	1.5 V
Output Switching Voltage, V_S	$0.5 V_{CC}$	$0.5 V_{CC}$

6 Detailed Description

6.1 Overview

The eight flip-flops of the 'AC374 devices are D-type edge-triggered flip-flops. On the positive transition of the clock (CLK) input, the Q outputs are set to the logic levels set up at the data (D) inputs.

A buffered output-enable (\overline{OE}) input can be used to place the eight outputs in either a normal logic state (high or low logic levels) or the high-impedance state. In the high-impedance state, the outputs neither load nor drive the bus lines significantly. The high-impedance state and the increased drive provide the capability to drive bus lines in bus-organized systems without need for interface or pullup components.

\overline{OE} does not affect internal operations of the flip-flop. Old data can be retained or new data can be entered while the outputs are in the high-impedance state.

The RCA-CD54/74AC374 and CD54/74AC534 and the CD54/74ACT374 and CD54/74ACT534 octal D-type, 3-state, positive-edge triggered flip-flops use the RCA ADVANCED CMOS technology. The eight flip-flops enter data into their registers on the LOW-to-HIGH transition of the clock (CP). The Output Enable (\overline{OE}) controls the 3-state outputs and is independent of the register operation. When the Output Enable (\overline{OE}) is HIGH, the outputs are in the high-impedance state. The CD54/74AC/ACT374 and CD54/74AC/ACT534 share the same pin configurations, but the CD54/74AC/ACT374 outputs are non-inverted while the CD54/74AC/ACT534 devices have inverted outputs. (For flow-through pin configurations, see CD54/74AC/ACT564 and CD54/74AC/ACT574.)

The CD74AC/ACT374 and CD74AC/ACT534 are supplied in 20-lead dual-in-line plastic packages (E suffix) and in 20-lead dual-in-line small-outline plastic packages (M suffix). Both package types are operable over the following temperature ranges: Commercial (0 to 70°C); Industrial (-40 to +85°C); and Extended Industrial/Military (-55 to +125°C).

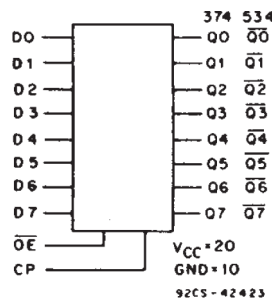

The CD54AC/ACT374 and CD54AC/ACT534, available in chip form (H suffix), are operable over the -55 to +125°C temperature range.

6.2 Functional Block Diagram



6.3 Device Functional Modes

Table 6-1. Truth Table

INPUTS			OUTPUTS	
			374	534
\overline{OE}	CP	Dn	Qn	\overline{Qn}
L		H	H	L
L		L	L	H
L	L	X	QO	QO
H	X	X	Z	Z

7 Application and Implementation

Note

Information in the following applications sections is not part of the TI component specification, and TI does not warrant its accuracy or completeness. TI's customers are responsible for determining suitability of components for their purposes, as well as validating and testing their design implementation to confirm system functionality.

7.1 Typical Application

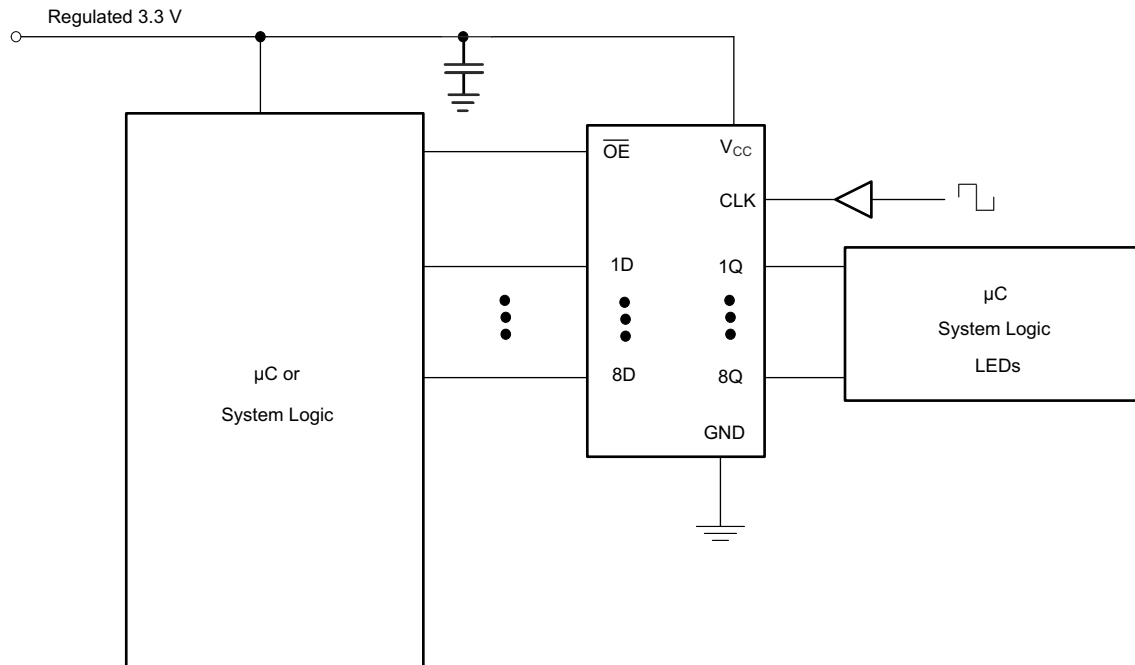

7.1.1 Design Requirements

This device uses CMOS technology and has balanced output drive. Care should be taken to avoid bus contention because it can drive currents that would exceed maximum limits. The high drive will also create fast edges into light loads so routing and load conditions should be considered to prevent ringing.

7.1.2 Detailed Design Procedure

- Recommended Input conditions
 - Rise time and fall time specs: See ($\Delta t/\Delta V$) in [Recommended Operating Conditions](#) table.
 - Specified high and low levels: See (V_{IH} and V_{IL}) in [Recommended Operating Conditions](#) table.
 - Inputs are overvoltage tolerant allowing them to go as high as 5.5 V at any valid V_{CC} .
- Recommend output conditions
 - Load currents should not exceed 50 mA per output and 100 mA total for the part.
 - Outputs should not be pulled above V_{CC} .

7.2 Power Supply Recommendations

The power supply can be any voltage between the min and max supply voltage rating located in [Section 4.3](#).

Each V_{CC} terminal should have a good bypass capacitor to prevent power disturbance. For devices with a single supply, TI recommends 0.1 μF and if there are multiple V_{CC} terminals, then TI recommends .01 μF or .022 μF for each power terminal. It is okay to parallel multiple bypass capacitors to reject different frequencies of noise. A 0.1 μF and 1 μF are commonly used in parallel. The bypass capacitor should be installed as close to the power terminal as possible for best results.

7.3 Layout

7.3.1 Layout Guidelines

When using multiple bit logic devices inputs should not ever float. In many cases, functions or parts of functions of digital logic devices are unused, for example, when only two inputs of a triple-input AND gate are used or only three of the four buffer gates are used. Such input pins should not be left unconnected because the undefined voltages at the outside connections result in undefined operational states. Specified below are the rules that must be observed under all circumstances. All unused inputs of digital logic devices must be connected to a high or low bias to prevent them from floating. The logic level that should be applied to any particular unused input depends on the function of the device. Generally they will be tied to GND or V_{CC} whichever make more sense or is more convenient. Floating outputs is generally acceptable, unless the part is a transceiver. If the transceiver has an output enable pin it will disable the outputs section of the part when asserted. This will not disable the input section of the I.O's so they also cannot float when disabled.

8 Device and Documentation Support

8.1 Documentation Support (Analog)

8.1.1 Related Documentation

The table below lists quick access links. Categories include technical documents, support and community resources, tools and software, and quick access to sample or buy.

Table 8-1. Related Links

PARTS	PRODUCT FOLDER	SAMPLE & BUY	TECHNICAL DOCUMENTS	TOOLS & SOFTWARE	SUPPORT & COMMUNITY
CD54AC374	Click here	Click here	Click here	Click here	Click here
CD74AC374	Click here	Click here	Click here	Click here	Click here
CD54ACT374	Click here	Click here	Click here	Click here	Click here
CD74ACT374	Click here	Click here	Click here	Click here	Click here
CD74AC534	Click here	Click here	Click here	Click here	Click here

8.2 Receiving Notification of Documentation Updates

To receive notification of documentation updates, navigate to the device product folder on [ti.com](#). Click on *Notifications* to register and receive a weekly digest of any product information that has changed. For change details, review the revision history included in any revised document.

8.3 Support Resources

[TI E2E™ support forums](#) are an engineer's go-to source for fast, verified answers and design help — straight from the experts. Search existing answers or ask your own question to get the quick design help you need.

Linked content is provided "AS IS" by the respective contributors. They do not constitute TI specifications and do not necessarily reflect TI's views; see TI's [Terms of Use](#).

8.4 Trademarks

TI E2E™ is a trademark of Texas Instruments.
 All trademarks are the property of their respective owners.

8.5 Electrostatic Discharge Caution



This integrated circuit can be damaged by ESD. Texas Instruments recommends that all integrated circuits be handled with appropriate precautions. Failure to observe proper handling and installation procedures can cause damage.

ESD damage can range from subtle performance degradation to complete device failure. Precision integrated circuits may be more susceptible to damage because very small parametric changes could cause the device not to meet its published specifications.

8.6 Glossary

[TI Glossary](#) This glossary lists and explains terms, acronyms, and definitions.

9 Revision History

NOTE: Page numbers for previous revisions may differ from page numbers in the current version.

Changes from Revision * (December 1998) to Revision A (March 2024)	Page
• Added <i>Device Information</i> table, <i>Pin Functions</i> table, <i>ESD Ratings</i> table, <i>Thermal Information</i> table, <i>Device Functional Modes, Application and Implementation</i> section, <i>Device and Documentation Support</i> section, and <i>Mechanical, Packaging, and Orderable Information</i> section	1
• Updated RθJA values: DW = 40 to 101.2, all values in °C/W	4

10 Mechanical, Packaging, and Orderable Information

The following pages include mechanical, packaging, and orderable information. This information is the most current data available for the designated devices. This data is subject to change without notice and revision of this document. For browser-based versions of this data sheet, refer to the left-hand navigation.

IMPORTANT NOTICE AND DISCLAIMER

TI PROVIDES TECHNICAL AND RELIABILITY DATA (INCLUDING DATA SHEETS), DESIGN RESOURCES (INCLUDING REFERENCE DESIGNS), APPLICATION OR OTHER DESIGN ADVICE, WEB TOOLS, SAFETY INFORMATION, AND OTHER RESOURCES "AS IS" AND WITH ALL FAULTS, AND DISCLAIMS ALL WARRANTIES, EXPRESS AND IMPLIED, INCLUDING WITHOUT LIMITATION ANY IMPLIED WARRANTIES OF MERCHANTABILITY, FITNESS FOR A PARTICULAR PURPOSE OR NON-INFRINGEMENT OF THIRD PARTY INTELLECTUAL PROPERTY RIGHTS.

These resources are intended for skilled developers designing with TI products. You are solely responsible for (1) selecting the appropriate TI products for your application, (2) designing, validating and testing your application, and (3) ensuring your application meets applicable standards, and any other safety, security, regulatory or other requirements.

These resources are subject to change without notice. TI grants you permission to use these resources only for development of an application that uses the TI products described in the resource. Other reproduction and display of these resources is prohibited. No license is granted to any other TI intellectual property right or to any third party intellectual property right. TI disclaims responsibility for, and you will fully indemnify TI and its representatives against, any claims, damages, costs, losses, and liabilities arising out of your use of these resources.

TI's products are provided subject to [TI's Terms of Sale](#) or other applicable terms available either on [ti.com](https://www.ti.com) or provided in conjunction with such TI products. TI's provision of these resources does not expand or otherwise alter TI's applicable warranties or warranty disclaimers for TI products.

TI objects to and rejects any additional or different terms you may have proposed.

Mailing Address: Texas Instruments, Post Office Box 655303, Dallas, Texas 75265
Copyright © 2024, Texas Instruments Incorporated

Looking for pricing, stock, or lifecycle information?

Click below to explore more details on WIN SOURCE:

 [View CD54AC374F3A on WIN SOURCE](#)

 [Texas Instruments](#) Information

Optimize Your Supply Chain with WIN SOURCE Solutions

-  Global Sourcing Solution
-  Obsolete Management
-  Cost Control Management
-  Shortage Management
-  Alternative Solution
-  Excess Inventory Management