



**THE DATASHEET OF  
CY7C1440AV33-250AXI**





**THIS SPEC IS OBSOLETE**

Spec No: 38-05383

Spec Title: CY7C1440AV33, 36-MBIT (1M X 36) PIPELINED SYNC SRAM

Replaced by: None

## 36-Mbit (1M × 36) Pipelined Sync SRAM

### Features

- Supports bus operation up to 250 MHz
- Available speed grades are 250 and 167 MHz
- Registered inputs and outputs for pipelined operation
- 3.3 V core power supply
- 2.5 V/3.3 V I/O power supply
- Fast clock-to-output times
  - 2.6 ns (for 250-MHz device)
- Provide high-performance 3-1-1 access rate
- User-selectable burst counter supporting Intel® Pentium® interleaved or linear burst sequences
- Separate processor and controller address strobes
- Synchronous self-timed writes
- Asynchronous output enable
- Single cycle chip deselect
- CY7C1440AV33 available in Pb-free 100-pin TQFP package, Pb-free 165-ball FBGA package.
- IEEE 1149.1 JTAG-compatible boundary scan
- “ZZ” sleep mode option

### Functional Description

The CY7C1440AV33 SRAM integrates 1M × 36 SRAM cells with advanced synchronous peripheral circuitry and a two-bit counter for internal burst operation. All synchronous inputs are gated by registers controlled by a positive-edge-triggered clock input (CLK). The synchronous inputs include all addresses, all data inputs, address-pipelining chip enable ( $\overline{CE}_1$ ), depth-expansion chip enables ( $\overline{CE}_2$  and  $\overline{CE}_3$ ), burst control inputs (ADSC, ADSP, and ADV), write enables ( $BW_x$  and BWE), and global write (GW). Asynchronous inputs include the output enable ( $\overline{OE}$ ) and the ZZ pin.

Addresses and chip enables are registered at rising edge of clock when either address strobe processor (ADSP) or address strobe controller (ADSC) are active. Subsequent burst addresses can be internally generated as controlled by the advance pin (ADV).

Address, data inputs, and write controls are registered on-chip to initiate a self-timed write cycle. This part supports byte write operations (see pin descriptions and truth table for further details). Write cycles can be one to two or four bytes wide as controlled by the byte write control inputs. GW when active LOW causes all bytes to be written.

The CY7C1440AV33 operates from a +3.3 V core power supply while all outputs may operate with either a +2.5 or +3.3 V supply. All inputs and outputs are JEDEC-standard JESD8-5-compatible.

For a complete list of related documentation, click [here](#).

### Selection Guide

Description	250 MHz	167 MHz	Unit
Maximum access time	2.6	3.4	ns
Maximum operating current	475	375	mA
Maximum CMOS standby current	120	120	mA

Logic Block Diagram – CY7C1440AV33

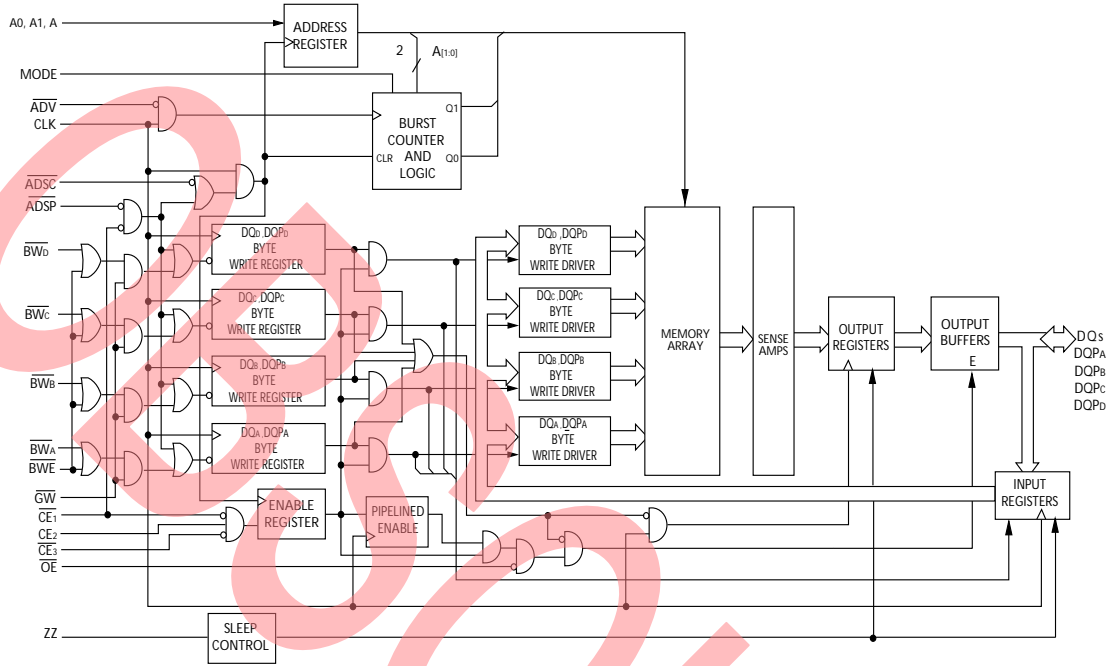

**Contents**

<b>Pin Configurations</b> .....	<b>4</b>	<b>TAP DC Electrical Characteristics and</b>	
<b>Pin Definitions</b> .....	<b>6</b>	<b>Operating Conditions</b> .....	<b>16</b>
<b>Functional Overview</b> .....	<b>7</b>	<b>Identification Register Definitions</b> .....	<b>17</b>
Single Read Accesses .....	7	<b>Scan Register Sizes</b> .....	<b>17</b>
Single Write Accesses Initiated by ADSP .....	7	<b>Instruction Codes</b> .....	<b>17</b>
Single Write Accesses Initiated by ADSC .....	8	<b>Boundary Scan Order</b> .....	<b>18</b>
Burst Sequences .....	8	<b>Maximum Ratings</b> .....	<b>19</b>
Sleep Mode .....	8	<b>Operating Range</b> .....	<b>19</b>
Interleaved Burst Address Table .....	8	<b>Electrical Characteristics</b> .....	<b>19</b>
Linear Burst Address Table .....	8	<b>Capacitance</b> .....	<b>20</b>
ZZ Mode Electrical Characteristics .....	8	<b>Thermal Resistance</b> .....	<b>20</b>
<b>Truth Table</b> .....	<b>9</b>	<b>AC Test Loads and Waveforms</b> .....	<b>20</b>
<b>Truth Table for Read/Write</b> .....	<b>10</b>	<b>Switching Characteristics</b> .....	<b>21</b>
<b>IEEE 1149.1 Serial Boundary Scan (JTAG)</b> .....	<b>11</b>	<b>Switching Waveforms</b> .....	<b>22</b>
Disabling the JTAG Feature .....	11	<b>Ordering Information</b> .....	<b>26</b>
Test Access Port (TAP) .....	11	Ordering Code Definitions .....	26
PERFORMING A TAP RESET .....	11	<b>Package Diagrams</b> .....	<b>27</b>
TAP REGISTERS .....	11	<b>Acronyms</b> .....	<b>29</b>
TAP Instruction Set .....	11	<b>Document Conventions</b> .....	<b>29</b>
<b>TAP Controller State Diagram</b> .....	<b>13</b>	Units of Measure .....	29
<b>TAP Controller Block Diagram</b> .....	<b>14</b>	<b>Document History Page</b> .....	<b>30</b>
<b>TAP Timing</b> .....	<b>14</b>	<b>Sales, Solutions, and Legal Information</b> .....	<b>33</b>
<b>TAP AC Switching Characteristics</b> .....	<b>15</b>	Worldwide Sales and Design Support .....	33
<b>3.3 V TAP AC Test Conditions</b> .....	<b>15</b>	Products .....	33
<b>3.3 V TAP AC Output Load Equivalent</b> .....	<b>15</b>	PSoC Solutions .....	33
<b>2.5 V TAP AC Test Conditions</b> .....	<b>15</b>		
<b>2.5 V TAP AC Output Load Equivalent</b> .....	<b>15</b>		



**Pin Configurations** (continued)

**Figure 2. 165-ball FBGA (15 × 17 × 1.4 mm) pinout**
**CY7C1440AV33 (1M × 36)**

	1	2	3	4	5	6	7	8	9	10	11
<b>A</b>	NC/288M	A	$\overline{CE}_1$	$\overline{BW}_C$	$\overline{BW}_B$	$\overline{CE}_3$	$\overline{BWE}$	$\overline{ADSC}$	$\overline{ADV}$	A	NC
<b>B</b>	NC/144M	A	CE2	$\overline{BW}_D$	$\overline{BW}_A$	CLK	$\overline{GW}$	$\overline{OE}$	$\overline{ADSP}$	A	NC/576M
<b>C</b>	DQP <sub>C</sub>	NC	V <sub>DDQ</sub>	V <sub>SS</sub>	V <sub>SS</sub>	V <sub>SS</sub>	V <sub>SS</sub>	V <sub>SS</sub>	V <sub>DDQ</sub>	NC/1G	DQP <sub>B</sub>
<b>D</b>	DQ <sub>C</sub>	DQ <sub>C</sub>	V <sub>DDQ</sub>	V <sub>DD</sub>	V <sub>SS</sub>	V <sub>SS</sub>	V <sub>SS</sub>	V <sub>DD</sub>	V <sub>DDQ</sub>	DQ <sub>B</sub>	DQ <sub>B</sub>
<b>E</b>	DQ <sub>C</sub>	DQ <sub>C</sub>	V <sub>DDQ</sub>	V <sub>DD</sub>	V <sub>SS</sub>	V <sub>SS</sub>	V <sub>SS</sub>	V <sub>DD</sub>	V <sub>DDQ</sub>	DQ <sub>B</sub>	DQ <sub>B</sub>
<b>F</b>	DQ <sub>C</sub>	DQ <sub>C</sub>	V <sub>DDQ</sub>	V <sub>DD</sub>	V <sub>SS</sub>	V <sub>SS</sub>	V <sub>SS</sub>	V <sub>DD</sub>	V <sub>DDQ</sub>	DQ <sub>B</sub>	DQ <sub>B</sub>
<b>G</b>	DQ <sub>C</sub>	DQ <sub>C</sub>	V <sub>DDQ</sub>	V <sub>DD</sub>	V <sub>SS</sub>	V <sub>SS</sub>	V <sub>SS</sub>	V <sub>DD</sub>	V <sub>DDQ</sub>	DQ <sub>B</sub>	DQ <sub>B</sub>
<b>H</b>	NC	NC	NC	V <sub>DD</sub>	V <sub>SS</sub>	V <sub>SS</sub>	V <sub>SS</sub>	V <sub>DD</sub>	NC	NC	ZZ
<b>J</b>	DQ <sub>D</sub>	DQ <sub>D</sub>	V <sub>DDQ</sub>	V <sub>DD</sub>	V <sub>SS</sub>	V <sub>SS</sub>	V <sub>SS</sub>	V <sub>DD</sub>	V <sub>DDQ</sub>	DQ <sub>A</sub>	DQ <sub>A</sub>
<b>K</b>	DQ <sub>D</sub>	DQ <sub>D</sub>	V <sub>DDQ</sub>	V <sub>DD</sub>	V <sub>SS</sub>	V <sub>SS</sub>	V <sub>SS</sub>	V <sub>DD</sub>	V <sub>DDQ</sub>	DQ <sub>A</sub>	DQ <sub>A</sub>
<b>L</b>	DQ <sub>D</sub>	DQ <sub>D</sub>	V <sub>DDQ</sub>	V <sub>DD</sub>	V <sub>SS</sub>	V <sub>SS</sub>	V <sub>SS</sub>	V <sub>DD</sub>	V <sub>DDQ</sub>	DQ <sub>A</sub>	DQ <sub>A</sub>
<b>M</b>	DQ <sub>D</sub>	DQ <sub>D</sub>	V <sub>DDQ</sub>	V <sub>DD</sub>	V <sub>SS</sub>	V <sub>SS</sub>	V <sub>SS</sub>	V <sub>DD</sub>	V <sub>DDQ</sub>	DQ <sub>A</sub>	DQ <sub>A</sub>
<b>N</b>	DQP <sub>D</sub>	NC	V <sub>DDQ</sub>	V <sub>SS</sub>	NC	A	NC	V <sub>SS</sub>	V <sub>DDQ</sub>	NC	DQP <sub>A</sub>
<b>P</b>	NC	NC/72M	A	A	TDI	A1	TDO	A	A	A	A
<b>R</b>	MODE	A	A	A	TMS	A0	TCK	A	A	A	A

## Pin Definitions

Name	I/O	Description
A <sub>0</sub> , A <sub>1</sub> , A	Input-synchronous	<b>Address inputs used to select one of the address locations.</b> Sampled at the rising edge of the CLK if ADSP or ADSC is active LOW, and CE <sub>1</sub> , CE <sub>2</sub> , and CE <sub>3</sub> <sup>[1]</sup> are sampled active. A1:A0 are fed to the two-bit counter.
$\overline{BW}_A$ , $\overline{BW}_B$ , $\overline{BW}_C$ , $\overline{BW}_D$	Input-synchronous	<b>Byte write select inputs, active LOW.</b> Qualified with $\overline{BWE}$ to conduct byte writes to the SRAM. Sampled on the rising edge of CLK.
GW	Input-synchronous	<b>Global write enable input, active LOW.</b> When asserted LOW on the rising edge of CLK, a global write is conducted (all bytes are written, regardless of the values on BW <sub>X</sub> and BWE).
$\overline{BWE}$	Input-synchronous	<b>Byte write enable input, active LOW.</b> Sampled on the rising edge of CLK. This signal must be asserted LOW to conduct a byte write.
CLK	Input-clock	<b>Clock input.</b> Used to capture all synchronous inputs to the device. Also used to increment the burst counter when ADV is asserted LOW, during a burst operation.
$\overline{CE}_1$	Input-synchronous	<b>Chip enable 1 input, active LOW.</b> Sampled on the rising edge of CLK. Used in conjunction with CE <sub>2</sub> and CE <sub>3</sub> to select/deselect the device. ADSP is ignored if $\overline{CE}_1$ is HIGH. $\overline{CE}_1$ is sampled only when a new external address is loaded.
CE <sub>2</sub>	Input-synchronous	<b>Chip enable 2 input, active HIGH.</b> Sampled on the rising edge of CLK. Used in conjunction with $\overline{CE}_1$ and CE <sub>3</sub> to select/deselect the device. CE <sub>2</sub> is sampled only when a new external address is loaded.
$\overline{CE}_3$	Input-synchronous	<b>Chip enable 3 input, active LOW.</b> Sampled on the rising edge of CLK. Used in conjunction with $\overline{CE}_1$ and CE <sub>2</sub> to select/deselect the device. Not available for AJ package version. Not connected for BGA. Where referenced, CE <sub>3</sub> is assumed active throughout this document for BGA. CE <sub>3</sub> is sampled only when a new external address is loaded.
$\overline{OE}$	Input-asynchronous	<b>Output enable, asynchronous input, active LOW.</b> Controls the direction of the I/O pins. When LOW, the I/O pins behave as outputs. When deasserted HIGH, I/O pins are tri-stated, and act as input data pins. $\overline{OE}$ is masked during the first clock of a read cycle when emerging from a deselected state.
ADV	Input-synchronous	<b>Advance input signal, sampled on the rising edge of CLK, active LOW.</b> When asserted, it automatically increments the address in a burst cycle.
$\overline{ADSP}$	Input-synchronous	<b>Address strobe from processor, sampled on the rising edge of CLK, active LOW.</b> When asserted LOW, addresses presented to the device are captured in the address registers. A1:A0 are also loaded into the burst counter. When $\overline{ADSP}$ and ADSC are both asserted, only $\overline{ADSP}$ is recognized. $\overline{ADSP}$ is ignored when $\overline{CE}_1$ is deasserted HIGH.
ADSC	Input-synchronous	<b>Address strobe from controller, sampled on the rising edge of CLK, active LOW.</b> When asserted LOW, addresses presented to the device are captured in the address registers. A1:A0 are also loaded into the burst counter. When ADSP and ADSC are both asserted, only ADSP is recognized.
ZZ	Input-asynchronous	<b>ZZ “sleep” input, active HIGH.</b> When asserted HIGH places the device in a non-time-critical “sleep” condition with data integrity preserved. For normal operation, this pin has to be LOW or left floating. ZZ pin has an internal pull-down.
DQ <sub>s</sub> , DQP <sub>X</sub>	I/O-synchronous	<b>Bidirectional data I/O lines.</b> As inputs, they feed into an on-chip data register that is triggered by the rising edge of CLK. As outputs, they deliver the data contained in the memory location specified by the addresses presented during the previous clock rise of the read cycle. The direction of the pins is controlled by $\overline{OE}$ . When $\overline{OE}$ is asserted LOW, the pins behave as outputs. When HIGH, DQ <sub>s</sub> and DQP <sub>X</sub> are placed in a tri-state condition.
V <sub>DD</sub>	Power supply	<b>Power supply inputs to the core of the device.</b>
V <sub>SS</sub>	Ground	<b>Ground for the core of the device.</b>
V <sub>SSQ</sub>	I/O ground	<b>Ground for the I/O circuitry.</b>

### Note

1. X = “Don’t Care.” H = Logic HIGH, L = Logic LOW.

**Pin Definitions** (continued)

Name	I/O	Description
V <sub>DDQ</sub>	I/O power supply	<b>Power supply for the I/O circuitry.</b>
MODE	Input-static	<b>Selects burst order.</b> When tied to GND selects linear burst sequence. When tied to V <sub>DD</sub> or left floating selects interleaved burst sequence. This is a strap pin and should remain static during device operation. Mode pin has an internal pull-up.
TDO	JTAG serial output synchronous	<b>Serial data-out to the JTAG circuit.</b> Delivers data on the negative edge of TCK. If the JTAG feature is not being utilized, this pin should be disconnected. This pin is not available on TQFP packages.
TDI	JTAG serial input synchronous	<b>Serial data-in to the JTAG circuit.</b> Sampled on the rising edge of TCK. If the JTAG feature is not being utilized, this pin can be disconnected or connected to V <sub>DD</sub> . This pin is not available on TQFP packages.
TMS	JTAG serial input synchronous	<b>Serial data-in to the JTAG circuit.</b> Sampled on the rising edge of TCK. If the JTAG feature is not being utilized, this pin can be disconnected or connected to V <sub>DD</sub> . This pin is not available on TQFP packages.
TCK	JTAG-clock	<b>Clock input to the JTAG circuitry.</b> If the JTAG feature is not being utilized, this pin must be connected to V <sub>SS</sub> . This pin is not available on TQFP packages.
NC	–	<b>No connects.</b> Not internally connected to the die
NC/72M, NC/144M, NC/288M, NC/576M, NC/1G	–	<b>No connects.</b> Not internally connected to the die. NC/72M, NC/144M, NC/288M, NC/576M and NC/1G are address expansion pins are not internally connected to the die.

**Functional Overview**

All synchronous inputs pass through input registers controlled by the rising edge of the clock. All data outputs pass through output registers controlled by the rising edge of the clock. Maximum access delay from the clock rise ( $t_{CO}$ ) is 2.6 ns (250-MHz device).

The CY7C1440AV33 supports secondary cache in systems utilizing either a linear or interleaved burst sequence. The interleaved burst order supports Pentium and i486™ processors. The linear burst sequence is suited for processors that utilize a linear burst sequence. The burst order is user selectable, and is determined by sampling the MODE input. Accesses can be initiated with either the processor address strobe (ADSP) or the controller address strobe (ADSC). Address advancement through the burst sequence is controlled by the ADV input. A two-bit on-chip wraparound burst counter captures the first address in a burst sequence and automatically increments the address for the rest of the burst access.

Byte write operations are qualified with the byte write enable (BWE) and byte write select (BW<sub>X</sub>) inputs. A global write enable (GW) overrides all byte write inputs and writes data to all four bytes. All writes are simplified with on-chip synchronous self-timed Write circuitry.

Three synchronous chip selects ( $\overline{CE}_1$ , CE<sub>2</sub>,  $\overline{CE}_3$ ) and an asynchronous output enable (OE) provide for easy bank selection and output tri-state control. ADSP is ignored if CE<sub>1</sub> is HIGH.

**Single Read Accesses**

This access is initiated when the following conditions are satisfied at clock rise: (1) ADSP or ADSC is asserted LOW, (2) CE<sub>1</sub>, CE<sub>2</sub>, CE<sub>3</sub> are all asserted active, and (3) the write signals (GW, BWE) are all asserted HIGH. ADSP is ignored if CE<sub>1</sub> is HIGH. The address presented to the address inputs (A) is stored into the address advancement logic and the address register while being presented to the memory array. The corresponding data is allowed to propagate to the input of the output registers. At the rising edge of the next clock the data is allowed to propagate through the output register and onto the data bus within 2.6 ns (250-MHz device) if OE is active LOW. The only exception occurs when the SRAM is emerging from a deselected state to a selected state, its outputs are always tri-stated during the first cycle of the access. After the first cycle of the access, the outputs are controlled by the OE signal. Consecutive single Read cycles are supported. Once the SRAM is deselected at clock rise by the chip select and either ADSP or ADSC signals, its output will tri-state immediately.

**Single Write Accesses Initiated by ADSP**

This access is initiated when both of the following conditions are satisfied at clock rise: (1) ADSP is asserted LOW, and (2) CE<sub>1</sub>, CE<sub>2</sub>, CE<sub>3</sub> are all asserted active. The address presented to A is loaded into the address register and the address advancement logic while being delivered to the memory array. The write signals (GW, BWE, and BW<sub>X</sub>) and ADV inputs are ignored during this first cycle.

ADSP-triggered write accesses require two clock cycles to complete. If GW is asserted LOW on the second clock rise, the data presented to the DQs inputs is written into the corresponding address location in the memory array. If GW is

HIGH, then the write operation is controlled by  $\overline{BWE}$  and  $\overline{BW_X}$  signals.

The CY7C1440AV33 provides byte write capability that is described in the Write Cycle Descriptions table. Asserting the byte write enable input (BWE) with the selected byte write ( $\overline{BW_X}$ ) input, will selectively write to only the desired bytes. Bytes not selected during a byte write operation will remain unaltered. A synchronous self-timed Write mechanism has been provided to simplify the write operations.

Because CY7C1440AV33 is a common I/O device, the output enable ( $\overline{OE}$ ) must be deasserted HIGH before presenting data to the DQs inputs. Doing so will tri-state the output drivers. As a safety precaution, DQs are automatically tri-stated whenever a Write cycle is detected, regardless of the state of  $\overline{OE}$ .

### Single Write Accesses Initiated by $\overline{ADSC}$

$\overline{ADSC}$  Write accesses are initiated when the following conditions are satisfied: (1)  $\overline{ADSC}$  is asserted LOW, (2)  $\overline{ADSP}$  is asserted HIGH, (3)  $\overline{CE}_1$ ,  $\overline{CE}_2$ ,  $\overline{CE}_3$  are all asserted active, and (4) the appropriate combination of the Write inputs ( $\overline{GW}$ ,  $\overline{BWE}$ , and  $\overline{BW_X}$ ) are asserted active to conduct a Write to the desired byte(s).  $\overline{ADSC}$ -triggered write accesses require a single clock cycle to complete. The address presented to A is loaded into the address register and the address advancement logic while being delivered to the memory array. The  $\overline{ADV}$  input is ignored during this cycle. If a global Write is conducted, the data presented to the DQs is written into the corresponding address location in the memory core. If a byte write is conducted, only the selected bytes are written. Bytes not selected during a byte write operation will remain unaltered. A synchronous self-timed write mechanism has been provided to simplify the Write operations.

Because CY7C1440AV33 is a common I/O device, the output enable ( $\overline{OE}$ ) must be deasserted HIGH before presenting data to the DQs inputs. Doing so will tri-state the output drivers. As a safety precaution, DQs are automatically tri-stated whenever a Write cycle is detected, regardless of the state of  $\overline{OE}$ .

### Burst Sequences

The CY7C1440AV33 provides a two-bit wraparound counter, fed by A1:A0, that implements either an interleaved or linear burst sequence. The interleaved burst sequence is designed specifically to support Intel Pentium applications. The linear burst sequence is designed to support processors that follow a linear burst sequence. The burst sequence is user selectable through the MODE input. Asserting  $\overline{ADV}$  LOW at clock rise will automatically increment the burst counter to the next address in the burst sequence. Both read and write burst operations are supported.

### ZZ Mode Electrical Characteristics

Parameter	Description	Test Conditions	Min	Max	Unit
$I_{DDZZ}$	Sleep mode standby current	$ZZ \geq V_{DD} - 0.2 V$	–	100	mA
$t_{ZZS}$	Device operation to ZZ	$ZZ \geq V_{DD} - 0.2 V$	–	$2t_{CYC}$	ns
$t_{ZZREC}$	ZZ recovery time	$ZZ \leq 0.2 V$	$2t_{CYC}$	–	ns
$t_{ZZI}$	ZZ active to sleep current	This parameter is sampled	–	$2t_{CYC}$	ns
$t_{RZZI}$	ZZ inactive to exit sleep current	This parameter is sampled	0	–	ns

### Sleep Mode

The ZZ input pin is an asynchronous input. Asserting ZZ places the SRAM in a power conservation “sleep” mode. Two clock cycles are required to enter into or exit from this “sleep” mode. While in this mode, data integrity is guaranteed. Accesses pending when entering the “sleep” mode are not considered valid nor is the completion of the operation guaranteed. The device must be deselected prior to entering the “sleep” mode.  $\overline{CE}_1$ ,  $\overline{CE}_2$ ,  $\overline{CE}_3$ ,  $\overline{ADSP}$ , and  $\overline{ADSC}$  must remain inactive for the duration of  $t_{ZZREC}$  after the ZZ input returns LOW.

### Interleaved Burst Address Table

(MODE = Floating or  $V_{DD}$ )

First Address A1:A0	Second Address A1:A0	Third Address A1:A0	Fourth Address A1:A0
00	01	10	11
01	00	11	10
10	11	00	01
11	10	01	00

### Linear Burst Address Table

(MODE = GND)

First Address A1:A0	Second Address A1:A0	Third Address A1:A0	Fourth Address A1:A0
00	01	10	11
01	10	11	00
10	11	00	01
11	00	01	10

### Truth Table

The truth table for CY7C1440AV33 follows. [2, 3, 4, 5, 6, 7]

Operation	Add. Used	CE <sub>1</sub>	CE <sub>2</sub>	CE <sub>3</sub>	ZZ	ADSP	ADSC	ADV	WRITE	OE	CLK	DQ
Deselect cycle, power-down	None	H	X	X	L	X	L	X	X	X	L-H	Tri-state
Deselect cycle, power-down	None	L	L	X	L	L	X	X	X	X	L-H	Tri-state
Deselect cycle, power-down	None	L	X	H	L	L	X	X	X	X	L-H	Tri-state
Deselect cycle, power-down	None	L	L	X	L	H	L	X	X	X	L-H	Tri-state
Deselect cycle, power-down	None	L	X	H	L	H	L	X	X	X	L-H	Tri-state
Sleep mode, power-down	None	X	X	X	H	X	X	X	X	X	X	Tri-state
READ cycle, begin burst	External	L	H	L	L	L	X	X	X	L	L-H	Q
READ cycle, begin burst	External	L	H	L	L	L	X	X	X	H	L-H	Tri-state
WRITE cycle, begin burst	External	L	H	L	L	H	L	X	L	X	L-H	D
READ cycle, begin burst	External	L	H	L	L	H	L	X	H	L	L-H	Q
READ cycle, begin burst	External	L	H	L	L	H	L	X	H	H	L-H	Tri-state
READ cycle, continue burst	Next	X	X	X	L	H	H	L	H	L	L-H	Q
READ cycle, continue burst	Next	X	X	X	L	H	H	L	H	H	L-H	Tri-state
READ cycle, continue burst	Next	H	X	X	L	X	H	L	H	L	L-H	Q
READ cycle, continue burst	Next	H	X	X	L	X	H	L	H	H	L-H	Tri-state
WRITE cycle, continue burst	Next	X	X	X	L	H	H	L	L	X	L-H	D
WRITE cycle, continue burst	Next	H	X	X	L	X	H	L	L	X	L-H	D
READ cycle, suspend burst	Current	X	X	X	L	H	H	H	H	L	L-H	Q
READ cycle, suspend burst	Current	X	X	X	L	H	H	H	H	H	L-H	Tri-state
READ cycle, suspend burst	Current	H	X	X	L	X	H	H	H	L	L-H	Q
READ cycle, suspend burst	Current	H	X	X	L	X	H	H	H	H	L-H	Tri-state
WRITE cycle, suspend burst	Current	X	X	X	L	H	H	H	L	X	L-H	D
WRITE cycle, suspend burst	Current	H	X	X	L	X	H	H	L	X	L-H	D

**Notes**

- X = "Don't Care." H = Logic HIGH, L = Logic LOW.
- WRITE = L when any one or more byte write enable signals and  $\overline{BWE} = L$  or  $\overline{GW} = L$ .  $\overline{WRITE} = H$  when all byte write enable signals,  $\overline{BWE}, \overline{GW} = H$ .
- The DQ pins are controlled by the current cycle and the OE signal. OE is asynchronous and is not sampled with the clock.
- CE<sub>1</sub>, CE<sub>2</sub>, and CE<sub>3</sub> are available only in the TQFP package. BGA package has only 2 chip selects CE<sub>1</sub> and CE<sub>2</sub>.
- The SRAM always initiates a read cycle when ADSP is asserted, regardless of the state of GW, BWE, or BW<sub>x</sub>. Writes may occur only on subsequent clocks after the ADSP or with the assertion of ADSC. As a result, OE must be driven HIGH prior to the start of the write cycle to allow the outputs to tri-state. OE is a don't care for the remainder of the write cycle.
- OE is asynchronous and is not sampled with the clock rise. It is masked internally during write cycles. During a read cycle all data bits are tri-state when  $\overline{OE}$  is inactive or when the device is deselected, and all data bits behave as output when OE is active (LOW).

## Truth Table for Read/Write

The truth table for Read/Write for CY7C1440AV33 follows. [8, 9, 10]

Function (CY7C1440AV33)	GW	BWE	BW <sub>D</sub>	BW <sub>C</sub>	BW <sub>B</sub>	BW <sub>A</sub>
Read	H	H	X	X	X	X
Read	H	L	H	H	H	H
Write byte A – (DQ <sub>A</sub> and DQP <sub>A</sub> )	H	L	H	H	H	L
Write byte B – (DQ <sub>B</sub> and DQP <sub>B</sub> )	H	L	H	H	L	H
Write bytes B, A	H	L	H	H	L	L
Write byte C – (DQ <sub>C</sub> and DQP <sub>C</sub> )	H	L	H	L	H	H
Write bytes C, A	H	L	H	L	H	L
Write bytes C, B	H	L	H	L	L	H
Write bytes C, B, A	H	L	H	L	L	L
Write byte D – (DQ <sub>D</sub> and DQP <sub>D</sub> )	H	L	L	H	H	H
Write bytes D, A	H	L	L	H	H	L
Write bytes D, B	H	L	L	H	L	H
Write bytes D, B, A	H	L	L	H	L	L
Write bytes D, C	H	L	L	L	H	H
Write bytes D, C, A	H	L	L	L	H	L
Write bytes D, C, B	H	L	L	L	L	H
Write all bytes	H	L	L	L	L	L
Write all bytes	L	X	X	X	X	X

### Notes

8. The DQ pins are controlled by the current cycle and the OE signal. OE is asynchronous and is not sampled with the clock.
9. BW<sub>x</sub> represents any byte write signal. To enable any byte write BW<sub>x</sub>, a Logic LOW signal should be applied at clock rise. Any number of byte writes can be enabled at the same time for any given write.
10. Table only lists a partial listing of the byte write combinations. Any combination of BW<sub>x</sub> is valid. Appropriate write will be done based on which byte write is active.

## IEEE 1149.1 Serial Boundary Scan (JTAG)

The CY7C1440AV33 incorporates a serial boundary scan test access port (TAP). This part is fully compliant with IEEE Standard 1149.1. The TAP operates using JEDEC-standard 3.3 V or 2.5 V I/O logic levels.

The CY7C1440AV33 contains a TAP controller, instruction register, boundary scan register, bypass register, and ID register.

### Disabling the JTAG Feature

It is possible to operate the SRAM without using the JTAG feature. To disable the TAP controller, TCK must be tied LOW ( $V_{SS}$ ) to prevent clocking of the device. TDI and TMS are internally pulled up and may be unconnected. They may alternately be connected to  $V_{DD}$  through a pull-up resistor. TDO should be left unconnected. Upon power-up, the device will come up in a reset state which will not interfere with the operation of the device.

### Test Access Port (TAP)

#### Test Clock (TCK)

The test clock is used only with the TAP controller. All inputs are captured on the rising edge of TCK. All outputs are driven from the falling edge of TCK.

#### Test Mode Select (TMS)

The TMS input is used to give commands to the TAP controller and is sampled on the rising edge of TCK. It is allowable to leave this ball unconnected if the TAP is not used. The ball is pulled up internally, resulting in a logic HIGH level.

#### Test Data-In (TDI)

The TDI ball is used to serially input information into the registers and can be connected to the input of any of the registers. The register between TDI and TDO is chosen by the instruction that is loaded into the TAP instruction register. For information about loading the instruction register, see the [TAP Controller State Diagram on page 13](#). TDI is internally pulled up and can be unconnected if the TAP is unused in an application. TDI is connected to the most significant bit (MSB) of any register.

#### Test Data-Out (TDO)

The TDO output ball is used to serially clock data-out from the registers. The output is active, depending upon the current state of the TAP state machine (see [Instruction Codes on page 17](#)). The output changes on the falling edge of TCK. TDO is connected to the least significant bit (LSB) of any register.

### Performing a TAP Reset

A RESET is performed by forcing TMS HIGH ( $V_{DD}$ ) for five rising edges of TCK. This RESET does not affect the operation of the SRAM and may be performed while the SRAM is operating.

At power-up, the TAP is reset internally to ensure that TDO comes up in a high Z state.

### TAP Registers

Registers are connected between the TDI and TDO balls and allow data to be scanned into and out of the SRAM test circuitry. Only one register can be selected at a time through the

instruction register. Data is serially loaded into the TDI ball on the rising edge of TCK. Data is output on the TDO ball on the falling edge of TCK.

#### Instruction Register

Three-bit instructions can be serially loaded into the instruction register. This register is loaded when it is placed between the TDI and TDO balls as shown in the [TAP Controller Block Diagram on page 14](#). Upon power-up, the instruction register is loaded with the IDCODE instruction. It is also loaded with the IDCODE instruction if the controller is placed in a reset state as described in the previous section.

When the TAP controller is in the Capture-IR state, the two least significant bits are loaded with a binary "01" pattern to allow for fault isolation of the board-level serial test data path.

#### Bypass Register

To save time when serially shifting data through registers, it is sometimes advantageous to skip certain chips. The bypass register is a single-bit register that can be placed between the TDI and TDO balls. This allows data to be shifted through the SRAM with minimal delay. The bypass register is set LOW ( $V_{SS}$ ) when the BYPASS instruction is executed.

#### Boundary Scan Register

The boundary scan register is connected to all the input and bidirectional balls on the SRAM.

The boundary scan register is loaded with the contents of the RAM I/O ring when the TAP controller is in the Capture-DR state and is then placed between the TDI and TDO balls when the controller is moved to the Shift-DR state. The EXTEST, SAMPLE/PRELOAD and SAMPLE Z instructions can be used to capture the contents of the I/O ring.

The Boundary Scan Order tables show the order in which the bits are connected. Each bit corresponds to one of the bumps on the SRAM package. The MSB of the register is connected to TDI, and the LSB is connected to TDO.

#### Identification (ID) Register

The ID register is loaded with a vendor-specific, 32-bit code during the Capture-DR state when the IDCODE command is loaded in the instruction register. The IDCODE is hardwired into the SRAM and can be shifted out when the TAP controller is in the Shift-DR state. The ID register has a vendor code and other information described in the [Identification Register Definitions on page 17](#).

### TAP Instruction Set

#### Overview

Eight different instructions are possible with the three bit instruction register. All combinations are listed in the [Instruction Codes on page 17](#). Three of these instructions are listed as RESERVED and should not be used. The other five instructions are described in detail below.

Instructions are loaded into the TAP controller during the Shift-IR state when the instruction register is placed between TDI and TDO. During this state, instructions are shifted through the instruction register through the TDI and TDO balls. To execute

the instruction once it is shifted in, the TAP controller needs to be moved into the Update-IR state.

#### IDCODE

The IDCODE instruction causes a vendor-specific, 32-bit code to be loaded into the instruction register. It also places the instruction register between the TDI and TDO balls and allows the IDCODE to be shifted out of the device when the TAP controller enters the Shift-DR state.

The IDCODE instruction is loaded into the instruction register upon power-up or whenever the TAP controller is given a test logic reset state.

#### SAMPLE Z

The SAMPLE Z instruction causes the boundary scan register to be connected between the TDI and TDO pins when the TAP controller is in a Shift-DR state. The SAMPLE Z command puts the output bus into a high Z state until the next command is given during the "Update IR" state.

#### SAMPLE/PRELOAD

SAMPLE/PRELOAD is a 1149.1 mandatory instruction. When the SAMPLE/PRELOAD instructions are loaded into the instruction register and the TAP controller is in the Capture-DR state, a snapshot of data on the inputs and output pins is captured in the boundary scan register.

The user must be aware that the TAP controller clock can only operate at a frequency up to 20 MHz, while the SRAM clock operates more than an order of magnitude faster. Because there is a large difference in the clock frequencies, it is possible that during the Capture-DR state, an input or output will undergo a transition. The TAP may then try to capture a signal while in transition (metastable state). This will not harm the device, but there is no guarantee as to the value that will be captured. Repeatable results may not be possible.

To guarantee that the boundary scan register will capture the correct value of a signal, the SRAM signal must be stabilized long enough to meet the TAP controller's capture set-up plus hold times ( $t_{CS}$  and  $t_{CH}$ ). The SRAM clock input might not be captured correctly if there is no way in a design to stop (or slow) the clock during a SAMPLE/PRELOAD instruction. If this is an issue, it is still possible to capture all other signals and simply ignore the value of the CK and CK captured in the boundary scan register.

Once the data is captured, it is possible to shift out the data by putting the TAP into the Shift-DR state. This places the boundary scan register between the TDI and TDO pins.

PRELOAD allows an initial data pattern to be placed at the latched parallel outputs of the boundary scan register cells prior to the selection of another boundary scan test operation.

The shifting of data for the SAMPLE and PRELOAD phases can occur concurrently when required – that is, while data captured is shifted out, the preloaded data can be shifted in.

#### BYPASS

When the BYPASS instruction is loaded in the instruction register and the TAP is placed in a Shift-DR state, the bypass register is placed between the TDI and TDO pins. The advantage of the BYPASS instruction is that it shortens the boundary scan path when multiple devices are connected together on a board.

#### EXTEST

The EXTEST instruction enables the preloaded data to be driven out through the system output pins. This instruction also selects the boundary scan register to be connected for serial access between the TDI and TDO in the shift-DR controller state.

#### EXTEST OUTPUT BUS TRI-STATE

IEEE Standard 1149.1 mandates that the TAP controller be able to put the output bus into a tri-state mode.

The boundary scan register has a special bit located at, bit #89 (for 165-ball FBGA package). When this scan cell, called the "extest output bus tri-state", is latched into the preload register during the "Update-DR" state in the TAP controller, it will directly control the state of the output (Q-bus) pins, when the EXTEST is entered as the current instruction. When HIGH, it will enable the output buffers to drive the output bus. When LOW, this bit will place the output bus into a high Z condition.

This bit can be set by entering the SAMPLE/PRELOAD or EXTEST command, and then shifting the desired bit into that cell, during the "Shift-DR" state. During "Update-DR", the value loaded into that shift-register cell will latch into the preload register. When the EXTEST instruction is entered, this bit will directly control the output Q-bus pins. Note that this bit is pre-set HIGH to enable the output when the device is powered-up, and also when the TAP controller is in the "Test-Logic-Reset" state.

#### Reserved

These instructions are not implemented but are reserved for future use. Do not use these instructions.

### TAP Controller State Diagram

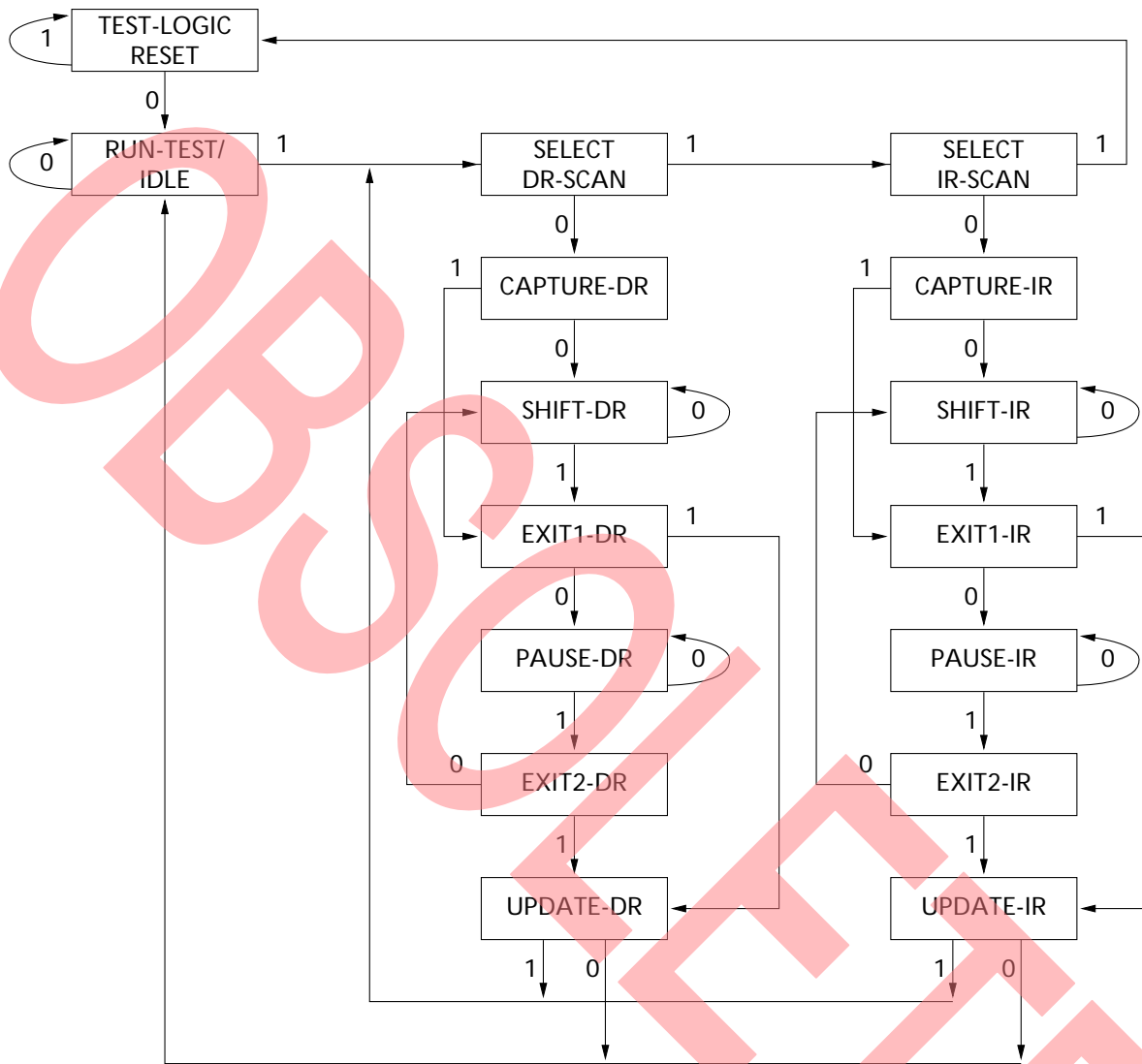

The 0/1 next to each state represents the value of TMS at the rising edge of TCK.

### TAP Controller Block Diagram

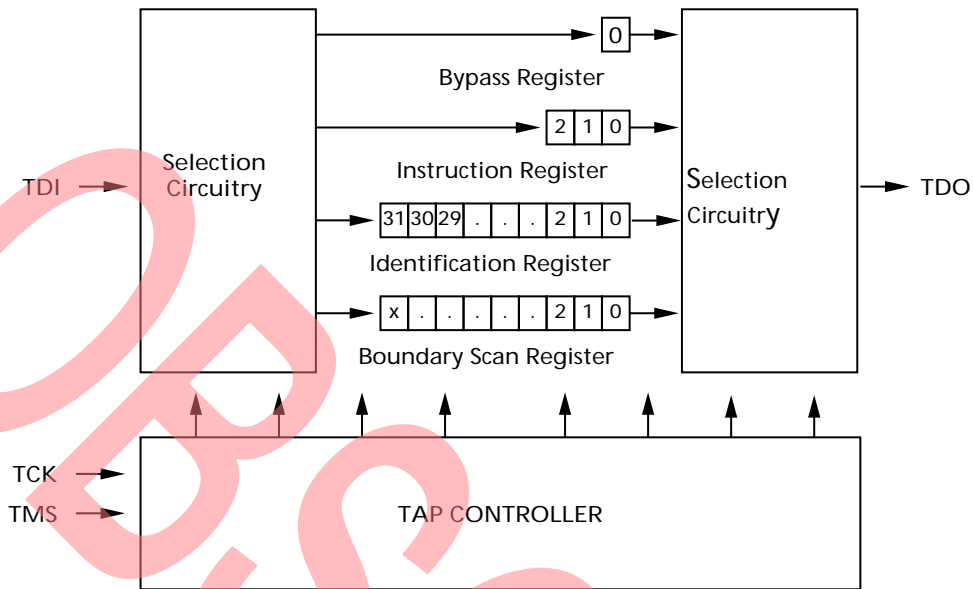

### TAP Timing

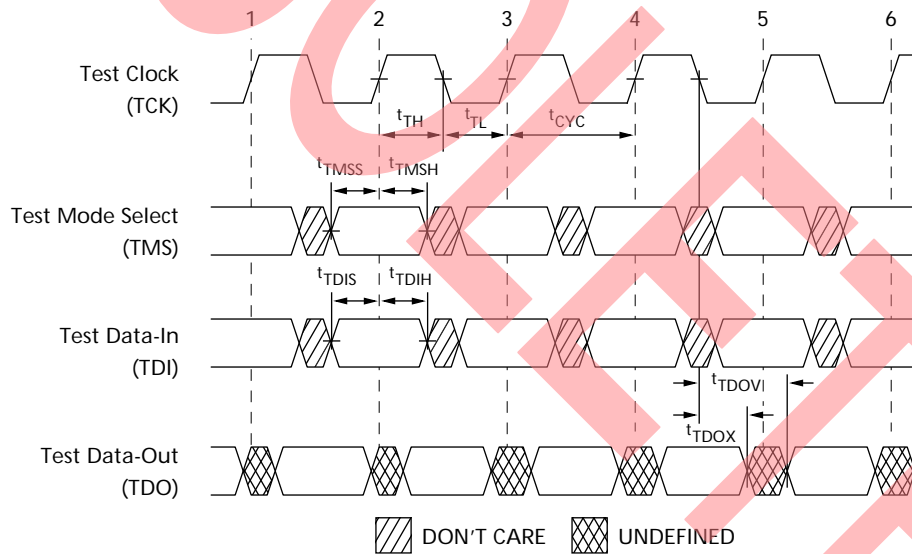

### TAP AC Switching Characteristics

Over the operating Range

Parameter <sup>[11, 12]</sup>	Description	Min	Max	Unit
<b>Clock</b>				
$t_{TCYC}$	TCK clock cycle time	50	–	ns
$t_{TF}$	TCK clock frequency	–	20	MHz
$t_{TH}$	TCK clock HIGH time	20	–	ns
$t_{TL}$	TCK clock LOW time	20	–	ns
<b>Output Times</b>				
$t_{TDOV}$	TCK clock LOW to TDO valid	–	10	ns
$t_{TDOX}$	TCK clock LOW to TDO invalid	0	–	ns
<b>Set-up Times</b>				
$t_{TMSS}$	TMS set-up to TCK clock rise	5	–	ns
$t_{TDIS}$	TDI set-up to TCK clock rise	5	–	ns
$t_{CS}$	Capture set-up to TCK rise	5	–	ns
<b>Hold Times</b>				
$t_{TMSH}$	TMS hold after TCK clock rise	5	–	ns
$t_{TDIH}$	TDI hold after clock rise	5	–	ns
$t_{CH}$	Capture hold after clock rise	5	–	ns

#### 3.3 V TAP AC Test Conditions

Input pulse levels .....  $V_{SS}$  to 3.3 V  
 Input rise and fall times ..... 1 ns  
 Input timing reference levels ..... 1.5 V  
 Output reference levels ..... 1.5 V  
 Test load termination supply voltage ..... 1.5 V

#### 3.3 V TAP AC Output Load Equivalent

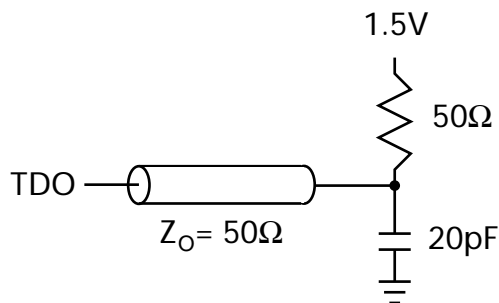

#### 2.5 V TAP AC Test Conditions

Input pulse levels .....  $V_{SS}$  to 2.5 V  
 Input rise and fall time ..... 1 ns  
 Input timing reference levels ..... 1.25 V  
 Output reference levels ..... 1.25 V  
 Test load termination supply voltage ..... 1.25 V

#### 2.5 V TAP AC Output Load Equivalent

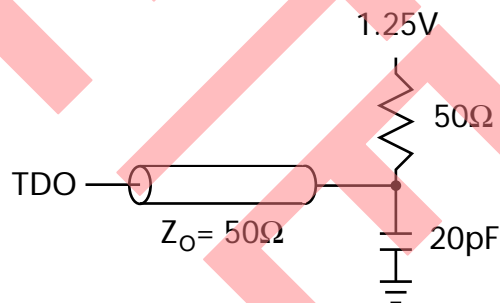

**Notes**

- 11.  $t_{CS}$  and  $t_{CH}$  refer to the set-up and hold time requirements of latching data from the boundary scan register.
- 12. Test conditions are specified using the load in TAP AC test Conditions.  $t_R/t_F = 1$  ns.

**TAP DC Electrical Characteristics and Operating Conditions**

 (0 °C < T<sub>A</sub> < +70 °C; V<sub>DD</sub> = 3.135 to 3.6 V unless otherwise noted)

Parameter <sup>[13]</sup>	Description	Test Conditions	Min	Max	Unit	
V <sub>OH1</sub>	Output HIGH voltage	I <sub>OH</sub> = -4.0 mA, V <sub>DDQ</sub> = 3.3 V	2.4	-	V	
		I <sub>OH</sub> = -1.0 mA, V <sub>DDQ</sub> = 2.5 V	2.0	-	V	
V <sub>OH2</sub>	Output HIGH voltage	I <sub>OH</sub> = -100 μA	V <sub>DDQ</sub> = 3.3 V	2.9	-	V
			V <sub>DDQ</sub> = 2.5 V	2.1	-	V
V <sub>OL1</sub>	Output LOW voltage	I <sub>OL</sub> = 8.0 mA	V <sub>DDQ</sub> = 3.3 V	-	0.4	V
		I <sub>OL</sub> = 1.0 mA	V <sub>DDQ</sub> = 2.5 V	-	0.4	V
V <sub>OL2</sub>	Output LOW voltage	I <sub>OL</sub> = 100 μA	V <sub>DDQ</sub> = 3.3 V	-	0.2	V
			V <sub>DDQ</sub> = 2.5 V	-	0.2	V
V <sub>IH</sub>	Input HIGH voltage		V <sub>DDQ</sub> = 3.3 V	2.0	V <sub>DD</sub> + 0.3	V
			V <sub>DDQ</sub> = 2.5 V	1.7	V <sub>DD</sub> + 0.3	V
V <sub>IL</sub>	Input LOW voltage		V <sub>DDQ</sub> = 3.3 V	-0.3	0.8	V
			V <sub>DDQ</sub> = 2.5 V	-0.3	0.7	V
I <sub>X</sub>	Input load current	GND ≤ V <sub>IN</sub> ≤ V <sub>DDQ</sub>	-5	5	μA	

**Note**

 13. All voltages referenced to V<sub>SS</sub> (GND).

### Identification Register Definitions

Instruction Field	CY7C1440AV33 (1M × 36)	Description
Revision number (31:29)	000	Describes the version number.
Device depth (28:24) <sup>[14]</sup>	01011	Reserved for internal use
Architecture/memory type(23:18)	000000	Defines memory type and architecture
Bus width/density(17:12)	100111	Defines width and density
Cypress JEDEC ID code (11:1)	00000110100	Allows unique identification of SRAM vendor.
ID register presence indicator (0)	1	Indicates the presence of an ID register.

### Scan Register Sizes

Register Name	Bit Size (× 36)
Instruction	3
Bypass	1
ID	32
Boundary scan order (165-ball FBGA package)	89

### Instruction Codes

Instruction	Code	Description
EXTEST	000	Captures the I/O ring contents.
IDCODE	001	Loads the ID register with the vendor ID code and places the register between TDI and TDO. This operation does not affect SRAM operations.
SAMPLE Z	010	Captures I/O ring contents. Places the boundary scan register between TDI and TDO. Forces all SRAM output drivers to a high Z state.
RESERVED	011	Do Not Use: This instruction is reserved for future use.
SAMPLE/PRELOAD	100	Captures I/O ring contents. Places the boundary scan register between TDI and TDO. Does not affect SRAM operation.
RESERVED	101	Do Not Use: This instruction is reserved for future use.
RESERVED	110	Do Not Use: This instruction is reserved for future use.
BYPASS	111	Places the bypass register between TDI and TDO. This operation does not affect SRAM operations.

**Note**

14. Bit #24 is "1" in the ID Register Definitions for both 2.5 V and 3.3 V versions of this device.

**Boundary Scan Order**

165-ball FBGA [15, 16]

**CY7C1440AV33 (1M × 36)**

Bit #	Ball ID
1	N6
2	N7
3	N10
4	P11
5	P8
6	R8
7	R9
8	P9
9	P10
10	R10
11	R11
12	H11
13	N11
14	M11
15	L11
16	K11
17	J11
18	M10
19	L10
20	K10
21	J10
22	H9
23	H10
24	G11
25	F11

Bit #	Ball ID
26	E11
27	D11
28	G10
29	F10
30	E10
31	D10
32	C11
33	A11
34	B11
35	A10
36	B10
37	A9
38	B9
39	C10
40	A8
41	B8
42	A7
43	B7
44	B6
45	A6
46	B5
47	A5
48	A4
49	B4
50	B3

Bit #	Ball ID
51	A3
52	A2
53	B2
54	C2
55	B1
56	A1
57	C1
58	D1
59	E1
60	F1
61	G1
62	D2
63	E2
64	F2
65	G2
66	H1
67	H3
68	J1
69	K1
70	L1
71	M1
72	J2
73	K2
74	L2
75	M2

Bit #	Ball ID
76	N1
77	N2
78	P1
79	R1
80	R2
81	P3
82	R3
83	P2
84	R4
85	P4
86	N5
87	P6
88	R6
89	Internal

**Notes**

- 15. Balls that are NC (No Connect) are preset LOW.
- 16. Bit# 89 is preset HIGH.

## Maximum Ratings

Exceeding maximum ratings may shorten the useful life of the device. User guidelines are not tested.

Storage temperature .....	-65 °C to +150 °C
Ambient temperature with power applied .....	-55 °C to +125 °C
Supply voltage on V <sub>DD</sub> relative to GND .....	-0.3 V to +4.6 V
Supply voltage on V <sub>DDQ</sub> relative to GND .....	-0.3 V to +V <sub>DD</sub>
DC voltage applied to outputs in tri-state .....	-0.5 V to V <sub>DDQ</sub> + 0.5 V

DC input voltage .....	-0.5 V to V <sub>DD</sub> + 0.5 V
Current into outputs (LOW) .....	20 mA
Static discharge voltage (per MIL-STD-883, method 3015) .....	> 2001 V
Latch-up current .....	> 200 mA

## Operating Range

Range	Ambient Temperature	V <sub>DD</sub>	V <sub>DDQ</sub>
Commercial	0 °C to +70 °C	3.3 V – 5% / + 10%	2.5 V – 5% to V <sub>DD</sub>
Industrial	-40 °C to +85 °C		

## Electrical Characteristics

Over the Operating Range

Parameter <sup>[17, 18]</sup>	Description	Test Conditions	Min	Max	Unit	
V <sub>DD</sub>	Power supply voltage		3.135	3.6	V	
V <sub>DDQ</sub>	I/O supply voltage	for 3.3 V I/O	3.135	V <sub>DD</sub>	V	
		for 2.5 V I/O	2.375	2.625	V	
V <sub>OH</sub>	Output HIGH voltage	for 3.3 V I/O, I <sub>OH</sub> = -4.0 mA	2.4	-	V	
		for 2.5 V I/O, I <sub>OH</sub> = -1.0 mA	2.0	-	V	
V <sub>OL</sub>	Output LOW voltage	for 3.3 V I/O, I <sub>OL</sub> = 8.0 mA	-	0.4	V	
		for 2.5 V I/O, I <sub>OL</sub> = 1.0 mA	-	0.4	V	
V <sub>IH</sub>	Input HIGH voltage <sup>[17]</sup>	for 3.3 V I/O	2.0	V <sub>DD</sub> + 0.3	V	
		for 2.5 V I/O	1.7	V <sub>DD</sub> + 0.3	V	
V <sub>IL</sub>	Input LOW voltage <sup>[17]</sup>	for 3.3 V I/O	-0.3	0.8	V	
		for 2.5 V I/O	-0.3	0.7	V	
I <sub>X</sub>	Input leakage current except ZZ and MODE	GND ≤ V <sub>I</sub> ≤ V <sub>DDQ</sub>	-5	5	μA	
	Input current of MODE	Input = V <sub>SS</sub>	-30	-	μA	
		Input = V <sub>DD</sub>	-	5	μA	
	Input current of ZZ	Input = V <sub>SS</sub>	-5	-	μA	
Input = V <sub>DD</sub>		-	30	μA		
I <sub>OZ</sub>	Output leakage current	GND ≤ V <sub>I</sub> ≤ V <sub>DDQ</sub> , output disabled	-5	5	μA	
I <sub>DD</sub>	V <sub>DD</sub> operating supply current	V <sub>DD</sub> = Max, I <sub>OUT</sub> = 0 mA, f = f <sub>MAX</sub> = 1/t <sub>CYC</sub>	4-ns cycle, 250 MHz	-	475	mA
			6-ns cycle, 167 MHz	-	375	mA
I <sub>SB1</sub>	Automatic CE power-down current – TTL inputs	V <sub>DD</sub> = Max, device deselected, V <sub>IN</sub> ≥ V <sub>IH</sub> or V <sub>IN</sub> ≤ V <sub>IL</sub> , f = f <sub>MAX</sub> = 1/t <sub>CYC</sub>	All speeds	-	225	mA
I <sub>SB2</sub>	Automatic CE power-down current – CMOS inputs	V <sub>DD</sub> = Max, device deselected, V <sub>IN</sub> ≤ 0.3 V or V <sub>IN</sub> ≥ V <sub>DDQ</sub> - 0.3 V, f = 0	All speeds	-	120	mA

### Notes

17. Overshoot: V<sub>IH(AC)</sub> < V<sub>DD</sub> + 1.5 V (Pulse width less than t<sub>CYC</sub>/2), undershoot: V<sub>IL(AC)</sub> > -2 V (Pulse width less than t<sub>CYC</sub>/2).  
 18. T<sub>Power-up</sub>: Assumes a linear ramp from 0 V to V<sub>DD(min)</sub> within 200 ms. During this time V<sub>IH</sub> < V<sub>DD</sub> and V<sub>DDQ</sub> ≤ V<sub>DD</sub>.

**Electrical Characteristics** (continued)

Over the Operating Range

Parameter [17, 18]	Description	Test Conditions	Min	Max	Unit
$I_{SB3}$	Automatic CE power-down current – CMOS inputs	$V_{DD} = \text{Max}$ , device deselected, or $V_{IN} \leq 0.3 \text{ V}$ or $V_{IN} \geq V_{DDQ} - 0.3 \text{ V}$ , $f = f_{MAX} = 1/t_{CYC}$	–	200	mA
$I_{SB4}$	Automatic CE Power-down current – TTL Inputs	$V_{DD} = \text{Max}$ , device deselected, $V_{IN} \geq V_{IH}$ or $V_{IN} \leq V_{IL}$ , $f = 0$	–	135	mA

**Capacitance**

Parameter [19]	Description	Test Conditions	100-pin TQFP Max	165-ball FBGA Max	Unit
$C_{IN}$	Input capacitance	$T_A = 25 \text{ }^\circ\text{C}$ , $f = 1 \text{ MHz}$ , $V_{DD} = 3.3 \text{ V}$ , $V_{DDQ} = 2.5 \text{ V}$	6.5	7	pF
$C_{CLK}$	Clock input capacitance		3	7	pF
$C_{I/O}$	Input/Output capacitance		5.5	6	pF

**Thermal Resistance**

Parameter [19]	Description	Test Conditions	100-pin TQFP Package	165-ball FBGA Package	Unit
$\Theta_{JA}$	Thermal resistance (junction to ambient)	Test conditions follow standard test methods and procedures for measuring thermal impedance, per EIA/JESD51.	25.21	20.8	$^\circ\text{C/W}$
$\Theta_{JC}$	Thermal resistance (junction to case)		2.28	3.2	$^\circ\text{C/W}$

**AC Test Loads and Waveforms**

Figure 3. AC Test Loads and Waveforms

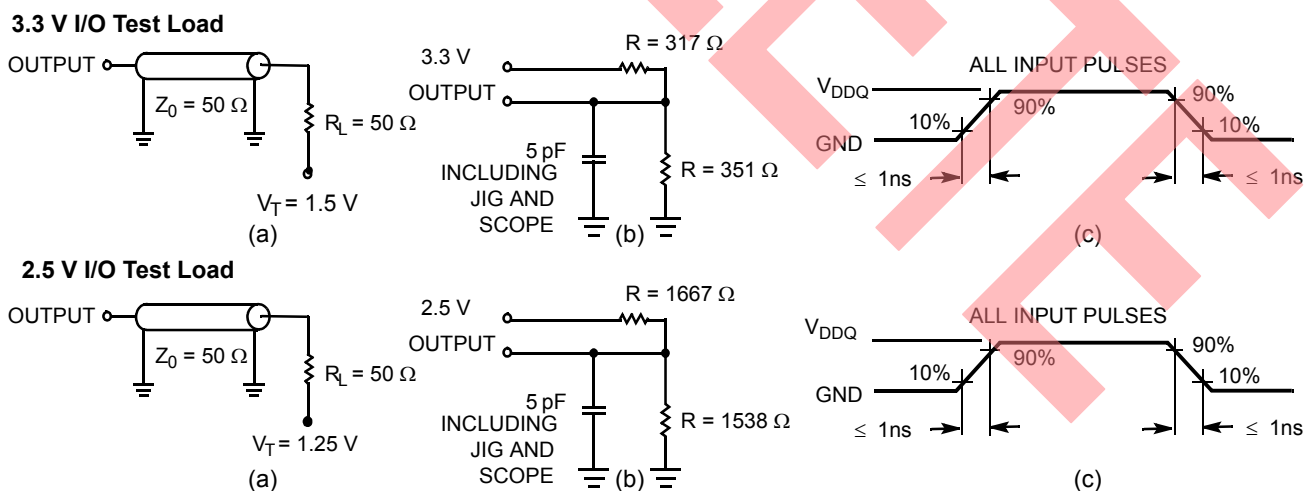

**Note**

19. Tested initially and after any design or process change that may affect these parameters.

## Switching Characteristics

Over the Operating Range

Parameter <sup>[20, 21]</sup>	Description	-250		-167		Unit
		Min	Max	Min	Max	
$t_{POWER}$	$V_{DD}$ (typical) to the first access <sup>[22]</sup>	1	–	1	–	ms
<b>Clock</b>						
$t_{CYC}$	Clock cycle time	4.0	–	6	–	ns
$t_{CH}$	Clock HIGH	1.5	–	2.4	–	ns
$t_{CL}$	Clock LOW	1.5	–	2.4	–	ns
<b>Output Times</b>						
$t_{CO}$	Data output valid after CLK rise	–	2.6	–	3.4	ns
$t_{DOH}$	Data output hold after CLK rise	1.0	–	1.5	–	ns
$t_{CLZ}$	Clock to low Z <sup>[23, 24, 25]</sup>	1.0	–	1.5	–	ns
$t_{CHZ}$	Clock to high Z <sup>[23, 24, 25]</sup>	–	2.6	–	3.4	ns
$t_{OEV}$	$\overline{OE}$ LOW to output valid	–	2.6	–	3.4	ns
$t_{OELZ}$	$\overline{OE}$ LOW to output low Z <sup>[23, 24, 25]</sup>	0	–	0	–	ns
$t_{OEZH}$	$\overline{OE}$ HIGH to output high Z <sup>[23, 24, 25]</sup>	–	2.6	–	3.4	ns
<b>Set-up Times</b>						
$t_{AS}$	Address set-up before CLK rise	1.2	–	1.5	–	ns
$t_{ADS}$	$\overline{ADSC}$ , $\overline{ADSP}$ set-up before CLK rise	1.2	–	1.5	–	ns
$t_{ADVS}$	$\overline{ADV}$ set-up before CLK rise	1.2	–	1.5	–	ns
$t_{WES}$	$\overline{GW}$ , $\overline{BWE}$ , $\overline{BW}_X$ set-up before CLK rise	1.2	–	1.5	–	ns
$t_{DS}$	Data input set-up before CLK rise	1.2	–	1.5	–	ns
$t_{CES}$	Chip enable set-up before CLK rise	1.2	–	1.5	–	ns
<b>Hold Times</b>						
$t_{AH}$	Address hold after CLK rise	0.3	–	0.5	–	ns
$t_{ADH}$	$\overline{ADSP}$ , $\overline{ADSC}$ hold after CLK rise	0.3	–	0.5	–	ns
$t_{ADVH}$	$\overline{ADV}$ hold after CLK rise	0.3	–	0.5	–	ns
$t_{WEH}$	$\overline{GW}$ , $\overline{BWE}$ , $\overline{BW}_X$ hold after CLK rise	0.3	–	0.5	–	ns
$t_{DH}$	Data input hold after CLK rise	0.3	–	0.5	–	ns
$t_{CEH}$	Chip enable hold after CLK rise	0.3	–	0.5	–	ns

### Notes

20. Timing reference level is 1.5 V when  $V_{DDQ} = 3.3$  V and is 1.25 V when  $V_{DDQ} = 2.5$  V.

21. Test conditions shown in (a) of [Figure 3 on page 20](#) unless otherwise noted.

22. This part has a voltage regulator internally;  $t_{POWER}$  is the time that the power needs to be supplied above  $V_{DD(\text{minimum})}$  initially before a read or write operation can be initiated.

23.  $t_{CHZ}$ ,  $t_{CLZ}$ ,  $t_{OELZ}$ , and  $t_{OEZH}$  are specified with AC test conditions shown in (b) of [Figure 3 on page 20](#). Transition is measured  $\pm 200$  mV from steady-state voltage.

24. At any given voltage and temperature,  $t_{OEZH}$  is less than  $t_{OELZ}$  and  $t_{CHZ}$  is less than  $t_{CLZ}$  to eliminate bus contention between SRAMs when sharing the same data bus. These specifications do not imply a bus contention condition, but reflect parameters guaranteed over worst case user conditions. Device is designed to achieve high Z prior to low Z under the same system conditions.

25. This parameter is sampled and not 100% tested.

Switching Waveforms

Figure 4. Read Cycle Timing [26]

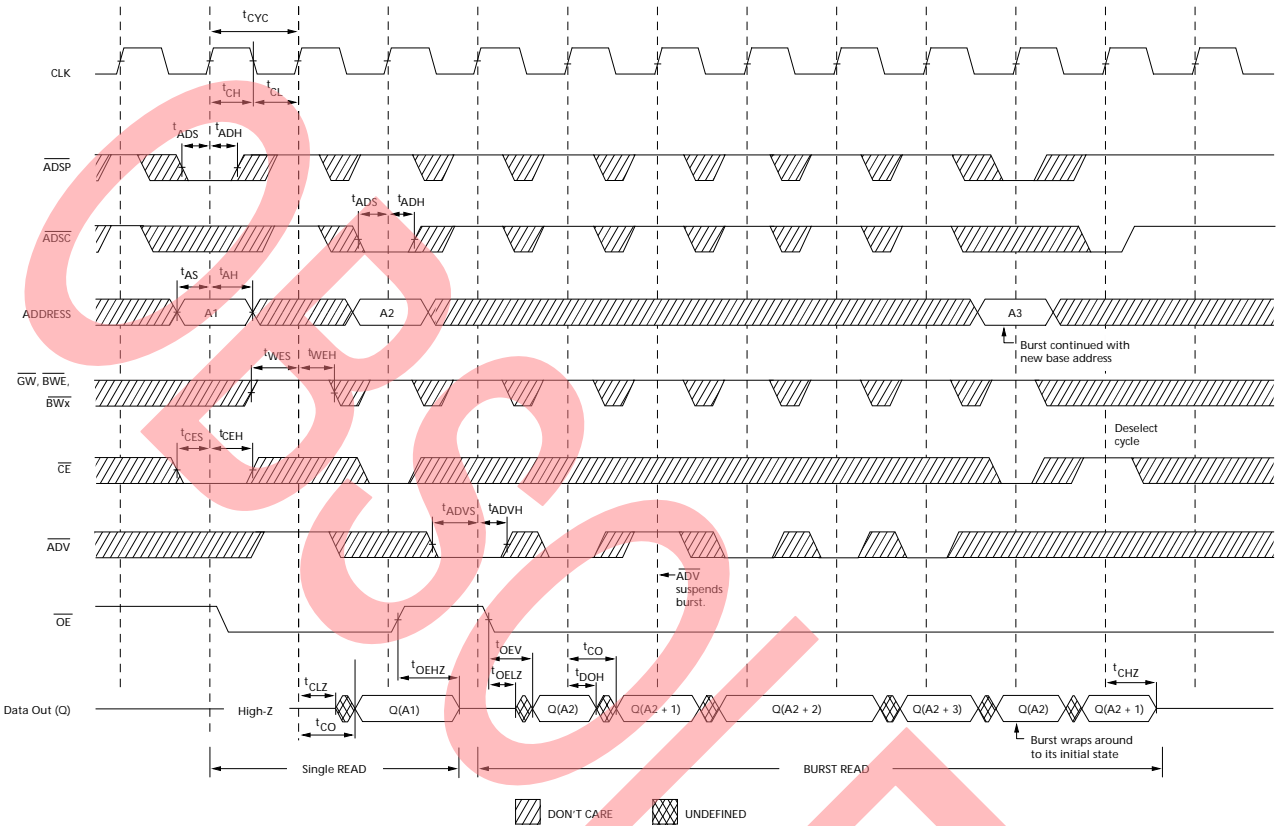

Note

26. On this diagram, when  $\overline{CE}$  is LOW:  $\overline{CE}_1$  is LOW,  $\overline{CE}_2$  is HIGH and  $\overline{CE}_3$  is LOW. When  $\overline{CE}$  is HIGH:  $\overline{CE}_1$  is HIGH or  $\overline{CE}_2$  is LOW or  $\overline{CE}_3$  is HIGH.

Switching Waveforms (continued)

Figure 5. Write Cycle Timing [27, 28]



Notes

- 27. On this diagram, when  $\overline{CE}$  is LOW:  $\overline{CE}_1$  is LOW,  $CE_2$  is HIGH and  $\overline{CE}_3$  is LOW. When  $\overline{CE}$  is HIGH:  $\overline{CE}_1$  is HIGH or  $CE_2$  is LOW or  $\overline{CE}_3$  is HIGH.
- 28. Full width write can be initiated by either GW LOW; or by GW HIGH, BWE LOW and BW<sub>x</sub> LOW.

Switching Waveforms (continued)

Figure 6. Read/Write Cycle Timing [29, 30, 31]

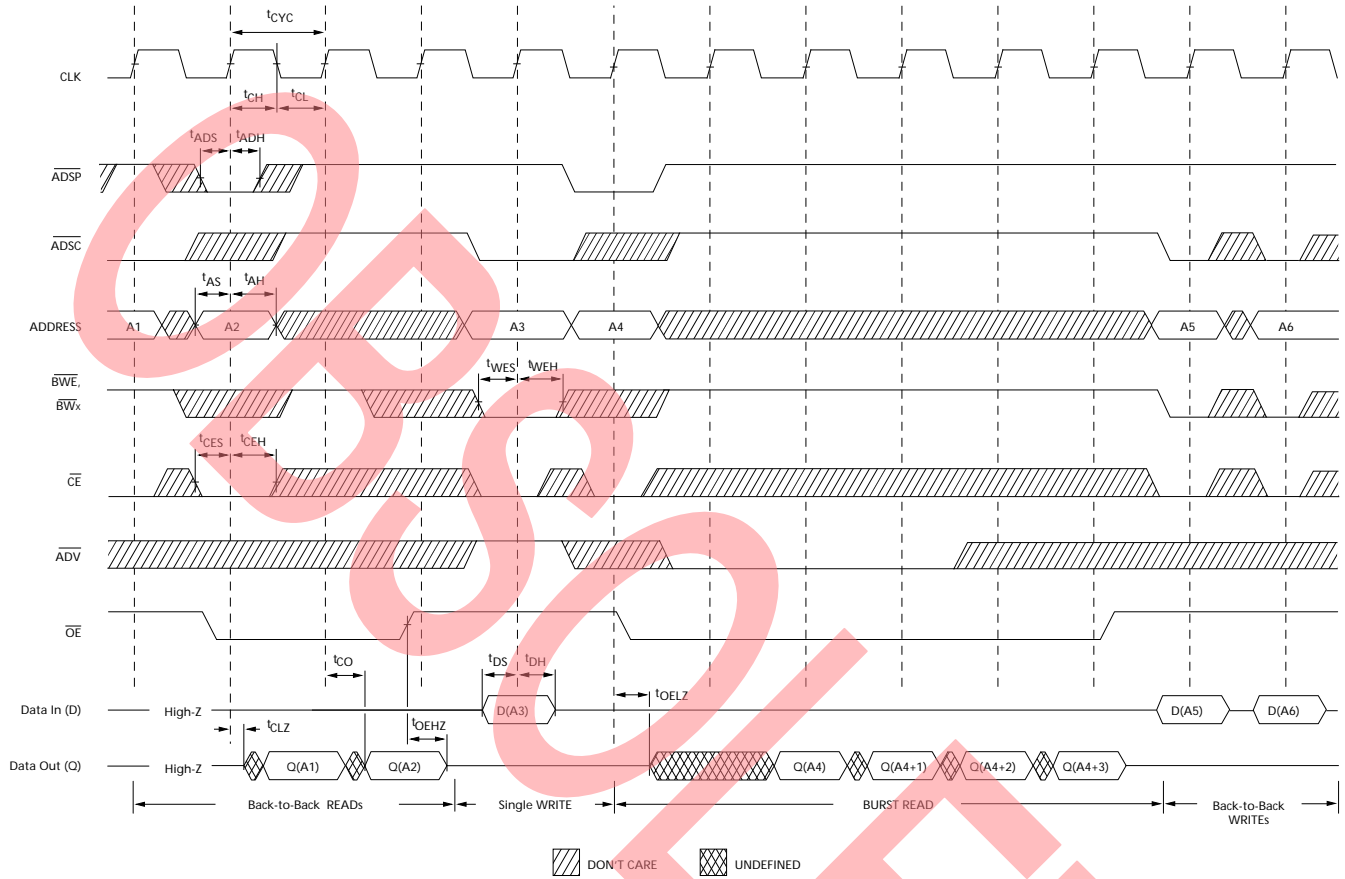

Notes

- 29. On this diagram, when  $\overline{CE}$  is LOW:  $\overline{CE}_1$  is LOW,  $\overline{CE}_2$  is HIGH and  $\overline{CE}_3$  is LOW. When  $\overline{CE}$  is HIGH:  $\overline{CE}_1$  is HIGH or  $\overline{CE}_2$  is LOW or  $\overline{CE}_3$  is HIGH.
- 30. The data bus (Q) remains in high Z following a Write cycle, unless a new read access is initiated by ADSP or ADSC.
- 31.  $\overline{GW}$  is HIGH.

Switching Waveforms (continued)

Figure 7. ZZ Mode Timing [32, 33]

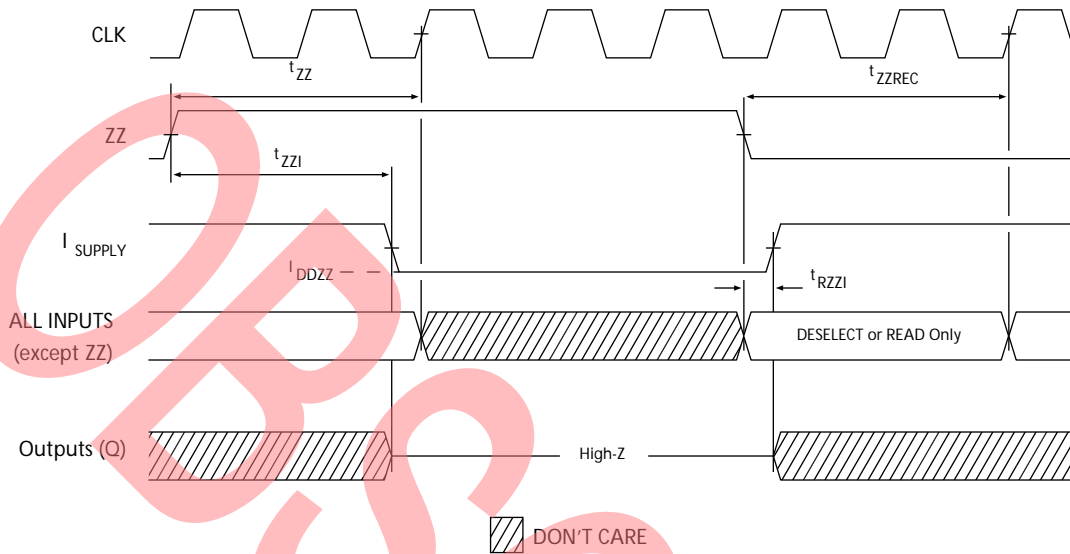

Notes

- 32. Device must be deselected when entering ZZ mode. See Cycle Descriptions table for all possible signal conditions to deselect the device.
- 33. DQs are in high Z when exiting ZZ sleep mode.

## Ordering Information

Cypress offers other versions of this type of product in different configurations and features. The following table contains only the list of parts that are currently available.

For a complete listing of all options, visit the Cypress website at [www.cypress.com](http://www.cypress.com) and refer to the product summary page at <http://www.cypress.com/products>, or contact your local sales representative.

Cypress maintains a worldwide network of offices, solution centers, manufacturer's representatives and distributors. To find the office closest to you, visit us at <http://www.cypress.com/go/datasheet/offices>.

Speed (MHz)	Ordering Code	Package Diagram	Part and Package Type	Operating Range
167	CY7C1440AV33-167AXC	51-85050	100-pin TQFP (14 × 20 × 1.4 mm) Pb-free	Commercial
250	CY7C1440AV33-250AXC	51-85050	100-pin TQFP (14 × 20 × 1.4 mm) Pb-free	Commercial
	CY7C1440AV33-250AXI		100-pin TQFP (14 × 20 × 1.4 mm) Pb-free	Industrial
	CY7C1440AV33-250BZXI	51-85195	165-ball FBGA (15 × 17 × 1.4 mm) Pb-free	

## Ordering Code Definitions

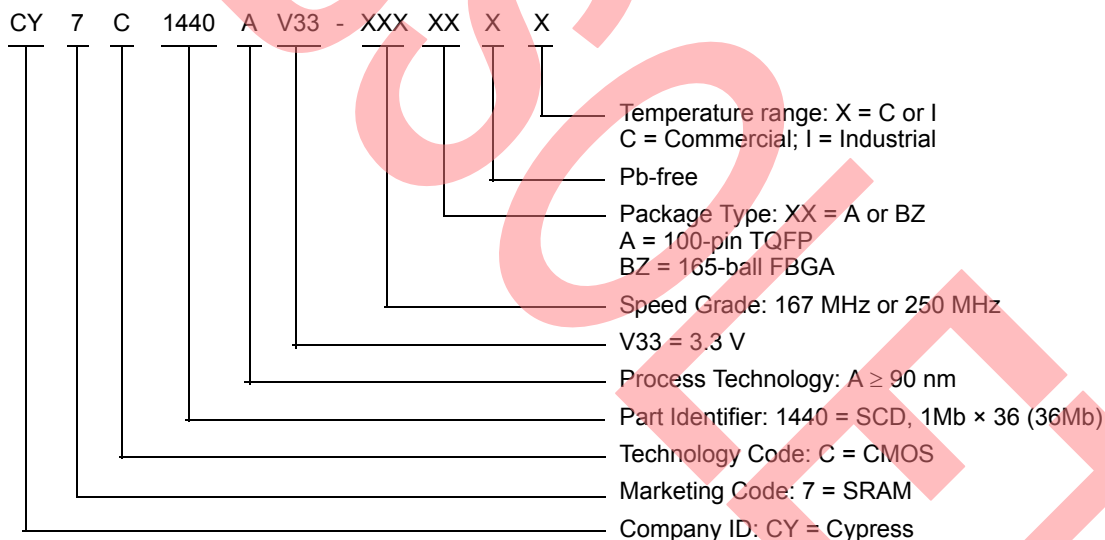

Package Diagrams

Figure 8. 100-pin TQFP (14 × 20 × 1.4 mm) A100RA Package Outline, 51-85050

100 Lead Thin Plastic Quad Flatpack 14 X 20 X 1.4mm

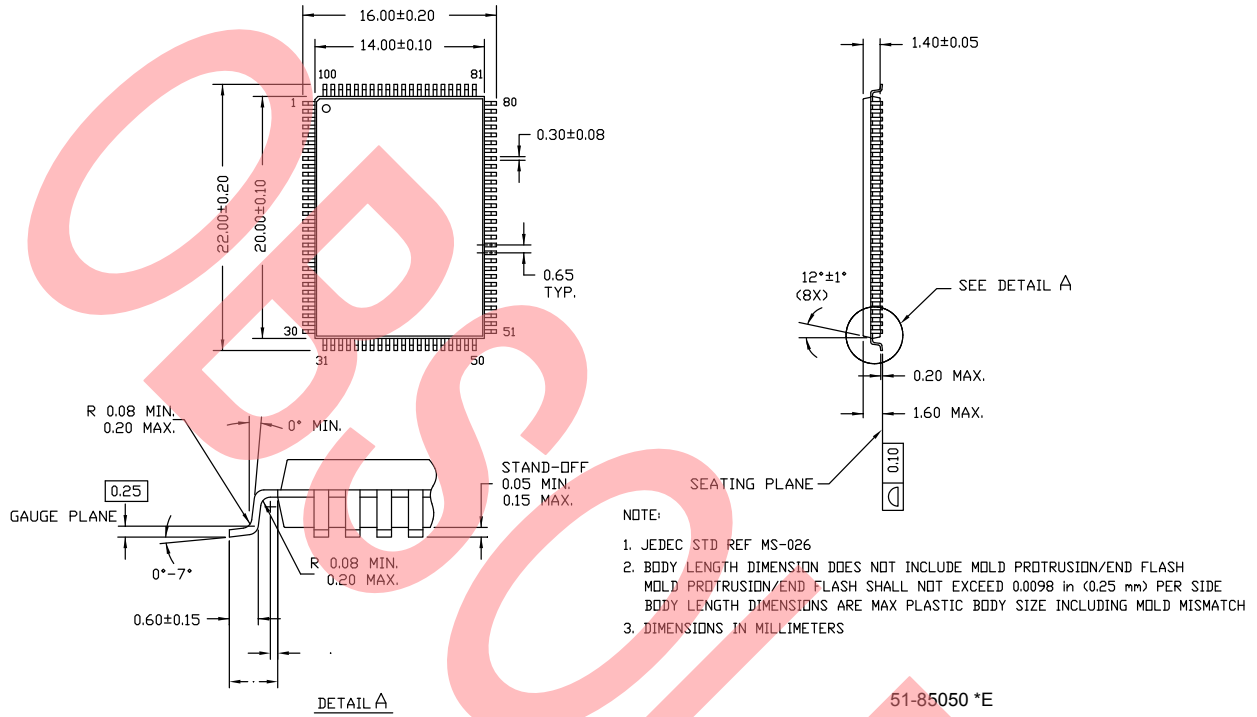

Package Diagrams (continued)

Figure 9. 165-ball FBGA (15 × 17 × 1.40 mm) (0.50 Ball Diameter) Package Outline, 51-85195

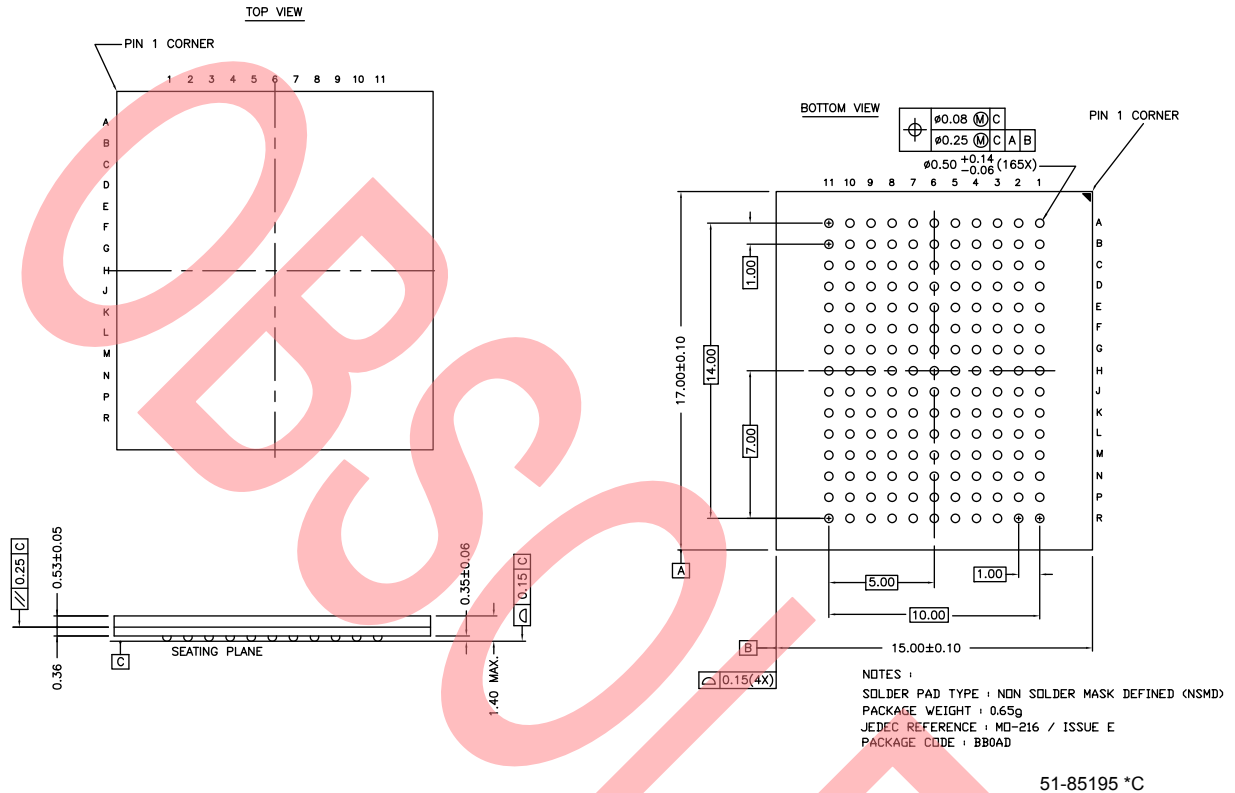

## Acronyms

Acronym	Description
BGA	ball grid array
$\overline{CE}$	chip enable
CMOS	complementary metal oxide semiconductor
EIA	electronic industries alliance
FBGA	fine-pitch ball grid array
I/O	input/output
JEDEC	joint electron devices engineering council
JTAG	joint test action group
LSB	least significant bit
MSB	most significant bit
NoBL	No Bus Latency
$\overline{OE}$	output enable
SRAM	static random access memory
TAP	test access port
TCK	test clock
TMS	test mode select
TDI	test data-in
TDO	test data-out
TQFP	thin quad flat pack
TTL	transistor-transistor logic

## Document Conventions

### Units of Measure

Symbol	Unit of Measure
°C	degree Celsius
MHz	megahertz
μA	microampere
mA	milliampere
ms	millisecond
mm	millimeter
ns	nanosecond
Ω	ohm
%	percent
pF	picofarad
V	volt
W	watt

**Document History Page**

Document Title: CY7C1440AV33, 36-Mbit (1M × 36) Pipelined Sync SRAM				
Document Number: 38-05383				
Rev.	ECN No.	Issue Date	Orig. of Change	Description of Change
**	124437	03/04/03	CJM	New data sheet.
*A	254910	See ECN	SYT	Updated Logic Block Diagram – CY7C1440AV33. Updated Logic Block Diagram – CY7C1442AV33. Updated Logic Block Diagram – CY7C1446AV33. Updated <a href="#">Identification Register Definitions</a> (Added Note 14 and referred the same in Device Depth (28:24)). Added Boundary Scan Order related information. Updated <a href="#">Electrical Characteristics</a> (Updated values of I <sub>DD</sub> , I <sub>X</sub> and I <sub>SB</sub> parameters). Updated <a href="#">Switching Characteristics</a> (Added t <sub>POWER</sub> parameter and its details). Updated <a href="#">Switching Waveforms</a> . Updated <a href="#">Package Diagrams</a> (Removed 119-ball PBGA package, changed 165-ball FBGA package from BB165C (15 × 17 × 1.20 mm) to BB165 (15 × 17 × 1.40 mm), changed 209-Lead PBGA BG209 (14 × 22 × 2.20 mm) to BB209A (14 × 22 × 1.76 mm)).
*B	306335	See ECN	SYT	Updated <a href="#">Pin Configurations</a> (Changed H9 pin from V <sub>SSQ</sub> to V <sub>SS</sub> for 209-ball FBGA). Updated <a href="#">Thermal Resistance</a> (Replaced $\Theta_{JA}$ and $\Theta_{JC}$ values from TBD to 25.21 °C/W and 2.58 °C/W respectively for 100-pin TQFP Package, replaced $\Theta_{JA}$ and $\Theta_{JC}$ values from TBD to respective Values for 165-ball FBGA and 209-ball FBGA Packages). Updated <a href="#">Electrical Characteristics</a> (Changed maximum value of I <sub>DD</sub> parameter from 450 mA, 400 mA, and 350 mA to 475 mA, 425 mA, and 375 mA for frequencies of 250 MHz, 200 MHz, and 167 MHz respectively, changed maximum value of I <sub>SB1</sub> parameter from 190 mA, 180 mA, and 170 mA to 225 mA for frequencies of 250 MHz, 200 MHz, and 167 MHz respectively, changed maximum value of I <sub>SB2</sub> from 80 mA to 100 mA, changed maximum value of I <sub>SB3</sub> from 180 mA, 170 mA, and 160 mA to 200 mA for frequencies of 250 MHz, 200 MHz, and 167 MHz respectively, changed maximum value of I <sub>SB4</sub> parameter from 100 mA to 110 mA). Updated <a href="#">Switching Characteristics</a> (Changed maximum value of t <sub>CO</sub> parameter from 3.0 ns to 3.2 ns for 200 MHz frequency, changed minimum value of t <sub>DOH</sub> parameter from 1.3 ns to 1.5 ns for 200 MHz frequency). Updated <a href="#">Ordering Information</a> (Added lead-free information for 100-pin TQFP, 165-ball FBGA and 209-ball FBGA Packages).
*C	332173	See ECN	SYT	Updated <a href="#">Pin Configurations</a> (Modified Address Expansion balls in the pinouts for 165-ball FBGA and 209-ball FBGA Package as per JEDEC standards). Updated <a href="#">Operating Range</a> (Added Industrial Temperature Range). Updated <a href="#">Electrical Characteristics</a> (Updated Test Conditions of V <sub>OL</sub> , V <sub>OH</sub> parameters, changed maximum value of I <sub>SB2</sub> and I <sub>SB4</sub> parameters from 100 mA and 110 mA to 120 mA and 135 mA respectively). Updated <a href="#">Capacitance</a> (Changed value of C <sub>IN</sub> , C <sub>CLK</sub> and C <sub>I/O</sub> to 7 pF, 7 pF, and 6 pF from 5 pF, 5 pF, and 7 pF for 165-ball FBGA Package). Updated <a href="#">Ordering Information</a> (By Shading and Unshading MPNs as per availability). Updated <a href="#">Package Diagrams</a> (Included 100-pin TQFP Package Diagram).

Document History Page (continued)

Document Title: CY7C1440AV33, 36-Mbit (1M × 36) Pipelined Sync SRAM Document Number: 38-05383				
Rev.	ECN No.	Issue Date	Orig. of Change	Description of Change
*D	417547	See ECN	RXU	<p>Changed status from Preliminary to Final.</p> <p>Changed address of Cypress Semiconductor Corporation from “3901 North First Street” to “198 Champion Court”.</p> <p>Updated <a href="#">Electrical Characteristics</a> (Updated Note 18 (Changed test condition from <math>V_{IH} \leq V_{DD}</math> to <math>V_{IH} &lt; V_{DD}</math>), changed “Input Load Current except ZZ and MODE” to “Input Leakage Current except ZZ and MODE” in the description of <math>I_X</math> parameter, changed minimum value of <math>I_X</math> corresponding to Input current of MODE (Input = <math>V_{SS}</math>) from <math>-5 \mu A</math> to <math>-30 \mu A</math>, changed maximum value of <math>I_X</math> corresponding to Input current of MODE (Input = <math>V_{DD}</math>) from <math>30 \mu A</math> to <math>5 \mu A</math> respectively, changed minimum value of <math>I_X</math> corresponding to Input current of ZZ (Input = <math>V_{SS}</math>) from <math>-30 \mu A</math> to <math>-5 \mu A</math>, changed maximum value of <math>I_X</math> corresponding to Input current of ZZ (Input = <math>V_{DD}</math>) from <math>5 \mu A</math> to <math>30 \mu A</math>).</p> <p>Updated <a href="#">Ordering Information</a> (Updated part numbers, replaced Package Name column with Package Diagram in the Ordering Information table).</p> <p>Updated <a href="#">Package Diagrams</a>.</p>
*E	473650	See ECN	VKN	<p>Updated <a href="#">TAP AC Switching Characteristics</a> (Changed minimum value of <math>t_{TH}</math>, <math>t_{TL}</math> parameters from 25 ns to 20 ns, changed maximum value of <math>t_{TDOV}</math> parameter from 5 ns to 10 ns).</p> <p>Updated <a href="#">Maximum Ratings</a> (Added the Maximum Rating for Supply Voltage on <math>V_{DDQ}</math> Relative to GND).</p> <p>Updated <a href="#">Ordering Information</a> (Updated part numbers).</p>
*F	2897278	03/22/2010	NJY	<p>Updated <a href="#">Ordering Information</a> (Removed obsolete part numbers).</p> <p>Updated <a href="#">Package Diagrams</a>.</p>
*G	3044512	10/01/2010	NJY	<p>Added <a href="#">Ordering Code Definitions</a>.</p> <p>Added <a href="#">Acronyms and Units of Measure</a>.</p> <p>Minor edits.</p> <p>Updated to new template.</p>
*H	3055212	10/11/2010	NJY	<p>Updated <a href="#">Ordering Information</a> (Updated part numbers).</p>
*I	3357006	08/29/2011	PRIT	<p>Updated <a href="#">Package Diagrams</a>.</p> <p>Updated to new template.</p>
*J	3424238	11/15/2011	PRIT	<p>Updated <a href="#">Ordering Information</a> (Updated part numbers).</p> <p>Updated <a href="#">Package Diagrams</a>.</p>

Document History Page (continued)

Document Title: CY7C1440AV33, 36-Mbit (1M × 36) Pipelined Sync SRAM Document Number: 38-05383				
Rev.	ECN No.	Issue Date	Orig. of Change	Description of Change
*K	3616631	05/14/2012	PRIT	<p>Updated <a href="#">Features</a> (Removed 200 MHz frequency related information, removed CY7C1442AV33, CY7C1446AV33 related information, removed 209-ball FBGA package related information).</p> <p>Updated <a href="#">Functional Description</a> (Removed CY7C1442AV33, CY7C1446AV33 related information, removed the Note “For best-practices recommendations, please refer to the Cypress application note <i>System Design Guidelines</i> on <a href="http://www.cypress.com">www.cypress.com</a>.” and its reference).</p> <p>Updated <a href="#">Selection Guide</a> (Removed 200 MHz frequency related information).</p> <p>Removed Logic Block Diagram – CY7C1442AV33.</p> <p>Removed Logic Block Diagram – CY7C1446AV33.</p> <p>Updated <a href="#">Pin Configurations</a> (Updated <a href="#">Figure 1</a> (Removed CY7C1442AV33 related information), updated <a href="#">Figure 2</a> (Removed CY7C1442AV33 related information), removed 209-ball FBGA package related information).</p> <p>Updated <a href="#">Functional Overview</a> (Removed CY7C1442AV33, CY7C1446AV33 related information).</p> <p>Updated <a href="#">Truth Table</a> (Removed CY7C1442AV33, CY7C1446AV33 related information).</p> <p>Removed Truth Table for Read/Write (Corresponding to CY7C1442AV33).</p> <p>Removed Truth Table for Read/Write (Corresponding to CY7C1446AV33).</p> <p>Updated <a href="#">IEEE 1149.1 Serial Boundary Scan (JTAG)</a> (Removed CY7C1442AV33, CY7C1446AV33 related information).</p> <p>Updated <a href="#">Identification Register Definitions</a> (Removed CY7C1442AV33, CY7C1446AV33 related information).</p> <p>Updated <a href="#">Scan Register Sizes</a> (Removed “Bit Size (× 18)”, “Bit Size (× 72)” columns).</p> <p>Updated <a href="#">Boundary Scan Order</a> (Removed CY7C1442AV33 related information).</p> <p>Removed Boundary Scan Order (Corresponding to 209-ball FBGA package).</p> <p>Updated <a href="#">Electrical Characteristics</a> (Removed 200 MHz frequency related information).</p> <p>Updated <a href="#">Capacitance</a> (Removed 209-ball FBGA package related information).</p> <p>Updated <a href="#">Thermal Resistance</a> (Removed 209-ball FBGA package related information).</p> <p>Updated <a href="#">Switching Characteristics</a> (Removed 200 MHz frequency related information).</p> <p>Updated <a href="#">Package Diagrams</a> (Removed 209-ball FBGA Package related information (spec 51-85167)).</p>
*L	3749841	09/20/2012	PRIT	<p>No technical updates.</p> <p>Completing Sunset Review.</p>
*M	4598634	12/16/2014	PRIT	<p>Updated <a href="#">Functional Description</a>:</p> <p>Added “For a complete list of related documentation, click <a href="#">here</a>.” at the end.</p> <p>Updated <a href="#">Package Diagrams</a>:</p> <p>spec 51-85050 – Changed revision from *D to *E.</p>
*N	5507288	11/02/2016	PRIT	<p>Obsolete document.</p> <p>Completing Sunset Review.</p>

## Sales, Solutions, and Legal Information

### Worldwide Sales and Design Support

Cypress maintains a worldwide network of offices, solution centers, manufacturer's representatives, and distributors. To find the office closest to you, visit us at [Cypress Locations](#).

#### Products

<a href="#">Automotive</a>	<a href="#">cypress.com/go/automotive</a>
<a href="#">Clocks &amp; Buffers</a>	<a href="#">cypress.com/go/clocks</a>
<a href="#">Interface</a>	<a href="#">cypress.com/go/interface</a>
<a href="#">Lighting &amp; Power Control</a>	<a href="#">cypress.com/go/powerpsoc</a>
<a href="#">Memory</a>	<a href="#">cypress.com/go/memory</a>
<a href="#">PSoC</a>	<a href="#">cypress.com/go/psoc</a>
<a href="#">Touch Sensing</a>	<a href="#">cypress.com/go/touch</a>
<a href="#">USB Controllers</a>	<a href="#">cypress.com/go/USB</a>
<a href="#">Wireless/RF</a>	<a href="#">cypress.com/go/wireless</a>

#### PSoC® Solutions

[psoc.cypress.com/solutions](#)  
[PSoC 1](#) | [PSoC 3](#) | [PSoC 4](#) | [PSoC 5LP](#)

#### Cypress Developer Community

[Community](#) | [Forums](#) | [Blogs](#) | [Video](#) | [Training](#)

#### Technical Support

[cypress.com/go/support](#)

© Cypress Semiconductor Corporation, 2003-2016. The information contained herein is subject to change without notice. Cypress Semiconductor Corporation assumes no responsibility for the use of any circuitry other than circuitry embodied in a Cypress product. Nor does it convey or imply any license under patent or other rights. Cypress products are not warranted nor intended to be used for medical, life support, life saving, critical control or safety applications, unless pursuant to an express written agreement with Cypress. Furthermore, Cypress does not authorize its products for use as critical components in life-support systems where a malfunction or failure may reasonably be expected to result in significant injury to the user. The inclusion of Cypress products in life-support systems application implies that the manufacturer assumes all risk of such use and in doing so indemnifies Cypress against all charges.

Any Source Code (software and/or firmware) is owned by Cypress Semiconductor Corporation (Cypress) and is protected by and subject to worldwide patent protection (United States and foreign), United States copyright laws and international treaty provisions. Cypress hereby grants to licensee a personal, non-exclusive, non-transferable license to copy, use, modify, create derivative works of, and compile the Cypress Source Code and derivative works for the sole purpose of creating custom software and or firmware in support of licensee product to be used only in conjunction with a Cypress integrated circuit as specified in the applicable agreement. Any reproduction, modification, translation, compilation, or representation of this Source Code except as specified above is prohibited without the express written permission of Cypress.

Disclaimer: CYPRESS MAKES NO WARRANTY OF ANY KIND, EXPRESS OR IMPLIED, WITH REGARD TO THIS MATERIAL, INCLUDING, BUT NOT LIMITED TO, THE IMPLIED WARRANTIES OF MERCHANTABILITY AND FITNESS FOR A PARTICULAR PURPOSE. Cypress reserves the right to make changes without further notice to the materials described herein. Cypress does not assume any liability arising out of the application or use of any product or circuit described herein. Cypress does not authorize its products for use as critical components in life-support systems where a malfunction or failure may reasonably be expected to result in significant injury to the user. The inclusion of Cypress' product in a life-support systems application implies that the manufacturer assumes all risk of such use and in doing so indemnifies Cypress against all charges.

Use may be limited by and subject to the applicable Cypress software license agreement.

## Looking for pricing, stock, or lifecycle information?

Click below to explore more details on WIN SOURCE:

 [View CY7C1440AV33-250AXI on WIN SOURCE](#)

 [Cypress Semiconductor Corp](#) Information

## Optimize Your Supply Chain with WIN SOURCE Solutions

-  Global Sourcing Solution
-  Obsolete Management
-  Cost Control Management
-  Shortage Management
-  Alternative Solution
-  Excess Inventory Management