



**THE DATASHEET OF  
DS21448L**



[www.maxim-ic.com](http://www.maxim-ic.com)

### GENERAL DESCRIPTION

The DS21448 is a quad-port E1 or T1 line interface unit (LIU) for short-haul and long-haul applications. It incorporates four independent transmitters and four independent receivers in a single 144-pin PBGA or 128-pin LQFP package. The transmit drivers generate the necessary G.703 E1 waveshapes in 75Ω or 120Ω applications and the DSX-1 or CSU line build-outs of 0dB, -7.5dB, -15dB, and -22.5dB for T1 applications.

### APPLICATIONS

Integrated Multiservice Access Platforms  
 T1/E1 Cross-Connects, Multiplexers, and Channel Banks  
 Central-Office Switches and PBX Interfaces  
 T1/E1 LAN/WAN Routers  
 Wireless Base Stations

### ORDERING INFORMATION

PART*	TEMP RANGE	PIN-PACKAGE
DS21448	0°C to +70°C	144 TE-PBGA
DS21448+	0°C to +70°C	144 TE-PBGA
DS21448N	-40°C to +85°C	144 TE-PBGA
DS21448N+	-40°C to +85°C	144 TE-PBGA
DS21448L	0°C to +70°C	128 LQFP
DS21448L+	0°C to +70°C	128 LQFP
DS21448LN	-40°C to +85°C	128 LQFP
DS21448LN+	-40°C to +85°C	128 LQFP

+ Denotes lead-free/RoHS-compliant package.

\*All devices rated at 3.3V.

Pin Configurations appear in Section [11](#).

### FEATURES

- Four Complete E1, T1, or J1 LIUs
- Supports Long- and Short-Haul Trunks
- Internal Software-Selectable Receive-Side Termination for 75Ω/100Ω/120Ω
- 3.3V Power Supply
- 32-Bit or 128-Bit Crystal-Less Jitter Attenuator Requires Only a 2.048MHz Master Clock for E1 and T1, with the Option to Use 1.544MHz for T1
- Generates the Appropriate Line Build-Outs With and Without Return Loss for E1, and DSX-1 and CSU Line Build-Outs for T1
- AMI, HDB3, and B8ZS Encoding/Decoding
- 16.384MHz, 8.192MHz, 4.096MHz, or 2.048MHz Clock Output Synthesized to Recovered Clock
- Programmable Monitor Mode for Receiver
- Loopbacks and PRBS Pattern Generation/ Detection with Output for Received Errors
- Generates/Detects In-Band Loop Codes, 1 to 16 Bits, Including CSU Loop Codes
- 8-Bit Parallel or Serial Interface with Optional Hardware Mode
- Muxed and Nonmuxed Parallel Bus Supports Intel or Motorola
- Detects/Generates Blue (AIS) Alarms
- NRZ/Bipolar Interface for Tx/Rx Data I/O
- Transmit Open-Circuit Detection
- Receive Carrier Loss (RCL) Indication (G.775)
- High-Z State for TTIP and TRING
- 50mA<sub>RMS</sub> Transmit Current Limiter
- JTAG Boundary Scan Test Port per IEEE 1149.1
- Meets Latest E1 and T1 Specifications Including ANSI.403-1999, ANSI T1.408, AT&T TR 62411, ITU G.703, G.704, G.706, G.736, G.775, G.823, I.431, O.151, O.161, ETSI ETS 300 166, JTG.703, JTI.431, TBR12, TBR13, and CTR4

**Note:** Some revisions of this device may incorporate deviations from published specifications known as errata. Multiple revisions of any device may be simultaneously available through various sales channels. For information about device errata, click here: [www.maxim-ic.com/errata](http://www.maxim-ic.com/errata).

## TABLE OF CONTENTS

<b>1.</b>	<b>BLOCK DIAGRAMS .....</b>	<b>5</b>
<b>2.</b>	<b>PIN DESCRIPTION .....</b>	<b>7</b>
<b>3.</b>	<b>DETAILED DESCRIPTION .....</b>	<b>13</b>
3.1	DS21448 AND DS21Q348 DIFFERENCES.....	13
<b>4.</b>	<b>PORT OPERATION .....</b>	<b>14</b>
4.1	HARDWARE MODE.....	14
4.2	SERIAL PORT OPERATION.....	15
4.3	PARALLEL PORT OPERATION .....	18
4.3.1	<i>Device Power-Up and Reset</i> .....	18
4.3.2	<i>Register Map</i> .....	18
4.3.3	<i>Control Registers</i> .....	19
<b>5.</b>	<b>STATUS REGISTERS.....</b>	<b>23</b>
<b>6.</b>	<b>DIAGNOSTICS .....</b>	<b>28</b>
6.1	IN-BAND LOOP-CODE GENERATION AND DETECTION .....	28
6.2	LOOPBACKS .....	31
6.2.1	<i>Remote Loopback (RLB)</i> .....	31
6.2.2	<i>Local Loopback (LLB)</i> .....	31
6.2.3	<i>Analog Loopback (LLB)</i> .....	31
6.2.4	<i>Dual Loopback (DLB)</i> .....	31
6.3	PRBS GENERATION AND DETECTION .....	31
6.4	ERROR COUNTER.....	31
6.5	ERROR COUNTER UPDATE .....	32
6.6	ERROR INSERTION .....	32
<b>7.</b>	<b>ANALOG INTERFACE.....</b>	<b>33</b>
7.1	RECEIVER .....	33
7.2	TRANSMITTER .....	33
7.3	JITTER ATTENUATOR.....	34
7.4	G.703 SYNCHRONIZATION SIGNAL.....	34
<b>8.</b>	<b>JTAG BOUNDARY SCAN ARCHITECTURE AND TEST ACCESS PORT .....</b>	<b>43</b>
8.1	JTAG TAP CONTROLLER STATE MACHINE .....	43
8.2	INSTRUCTION REGISTER.....	45
8.3	TEST REGISTERS .....	46
<b>9.</b>	<b>OPERATING PARAMETERS .....</b>	<b>48</b>
<b>10.</b>	<b>AC TIMING PARAMETERS AND DIAGRAMS.....</b>	<b>49</b>
<b>11.</b>	<b>PIN CONFIGURATIONS .....</b>	<b>56</b>
11.1	144-PIN BGA .....	56
11.2	128-PIN LQFP.....	57
<b>12.</b>	<b>PACKAGE INFORMATION .....</b>	<b>58</b>
12.1	144-BALL TE-PBGA (56-G6020-001) .....	58
12.2	128-PIN LQFP (56-G4011-001).....	59
<b>13.</b>	<b>THERMAL INFORMATION .....</b>	<b>60</b>
<b>14.</b>	<b>REVISION HISTORY.....</b>	<b>60</b>

## LIST OF FIGURES

Figure 1-1. Block Diagram .....	5
Figure 1-2. Receive Logic Detail .....	6
Figure 1-3. Transmit Logic Detail .....	6
Figure 4-1. Serial Port Operation for Read Access (R = 1) Mode 1 .....	16
Figure 4-2. Serial Port Operation for Read Access (R = 1) Mode 2 .....	16
Figure 4-3. Serial Port Operation for Read Access (R = 1) Mode 3 .....	16
Figure 4-4. Serial Port Operation for Read Access (R = 1) Mode 4 .....	17
Figure 4-5. Serial Port Operation for Write Access (R = 0) Modes 1 and 2.....	17
Figure 4-6. Serial Port Operation for Write Access (R = 0) Modes 3 and 4.....	17
Figure 7-1. Basic Interface .....	36
Figure 7-2. Protected Interface Using Internal Receive Termination.....	37
Figure 7-3. Protected Interface Using External Receive Termination.....	38
Figure 7-4. Dual Connector-Protected Interface Using Receive Termination.....	39
Figure 7-5. E1 Transmit Pulse Template .....	40
Figure 7-6. T1 Transmit Pulse Template .....	41
Figure 7-7. Jitter Tolerance .....	42
Figure 7-8. Jitter Attenuation .....	42
Figure 8-1. JTAG Block Diagram.....	43
Figure 8-2. TAP Controller State Diagram.....	44
Figure 10-1. Intel Bus Read Timing (PBTS = 0, BIS0 = 0) .....	49
Figure 10-2. Intel Bus Write Timing (PBTS = 0, BIS0 = 0) .....	50
Figure 10-3. Motorola Bus Timing (PBTS = 1, BIS0 = 0).....	50
Figure 10-4. Intel Bus Read Timing (PBTS = 0, BIS0 = 1) .....	51
Figure 10-5. Intel Bus Write Timing (PBTS = 0, BIS0 = 1) .....	52
Figure 10-6. Motorola Bus Read Timing (PBTS = 1, BIS0 = 1).....	52
Figure 10-7. Motorola Bus Write Timing (PBTS = 1, BIS0 = 1) .....	52
Figure 10-8. Serial Bus Timing (BIS1 = 1, BIS0 = 0).....	53
Figure 10-9. Receive-Side Timing .....	54
Figure 10-10. Transmit-Side Timing .....	55

## LIST OF TABLES

Table 2-A. Bus Interface Selection .....	7
Table 2-B. Pin Assignments .....	7
Table 2-C. Parallel Interface Mode Pin Description .....	9
Table 2-D. Serial Interface Mode Pin Description .....	10
Table 2-E. Hardware Interface Mode Pin Description .....	11
Table 3-A. DS21448 vs. DS21Q348 Pin Differences .....	13
Table 4-A. Loopback Control in Hardware Mode .....	14
Table 4-B. Transmit Data Control in Hardware Mode.....	14
Table 4-C. Receive Sensitivity Settings in Hardware Mode .....	14
Table 4-D. Monitor Gain Settings in Hardware Mode .....	14
Table 4-E. Internal Rx Termination Select in Hardware Mode .....	14
Table 4-F. MCLK Selection in Hardware Mode .....	15
Table 4-G. Parallel Port Mode Selection .....	18
Table 4-H. Register Map .....	18
Table 4-I. Receive Sensitivity Settings .....	22
Table 4-J. Backplane Clock Select.....	22
Table 4-K. Monitor Gain Settings .....	22
Table 4-L. Internal Rx Termination Select .....	22
Table 5-A. Received Alarm Criteria .....	25
Table 5-B. Receive Level Indication .....	27
Table 6-A. Transmit Code Length .....	29
Table 6-B. Receive Code Length .....	29
Table 6-C. Definition of Received Errors .....	32
Table 6-D. Function of ECRS Bits and RNEG Pin.....	32
Table 7-A. Line Build-Out Select for E1 in Register CCR4 (ETS = 0) .....	34
Table 7-B. Line Build-Out Select for T1 in Register CCR4 (ETS = 1) .....	34
Table 7-C. Line Build-Out Select for E1 in Register CCR4 (ETS = 0) Using Alternate Transformer Configuration.....	35
Table 7-D. Transformer Specifications (3.3V Operation).....	35
Table 8-A. Instruction Codes for IEEE 1149.1 Architecture .....	45
Table 8-B. ID Code Structure .....	46
Table 8-C. Device ID Codes.....	46
Table 8-D. Boundary Scan Control Bits.....	47
Table 10-A. AC Characteristics—Multiplexed Parallel Port (BIS0 = 0).....	49
Table 10-B. AC Characteristics—Nonmultiplexed Parallel Port (BIS0 = 1) .....	51
Table 10-C. AC Characteristics—Serial Port (BIS1 = 1, BIS0 = 0).....	53
Table 10-D. AC Characteristics—Receive Side .....	54
Table 10-E. AC Characteristics—Transmit Side .....	55
Table 13-A. Thermal Characteristics—BGA.....	60
Table 13-B. Theta-JA ( $\theta_{JA}$ ) vs. Airflow—BGA .....	60
Table 13-C. Thermal Characteristics—LQFP .....	60
Table 13-D. Theta-JA ( $\theta_{JA}$ ) vs. Airflow—LQFP .....	60

# 1. BLOCK DIAGRAMS

Figure 1-1. Block Diagram

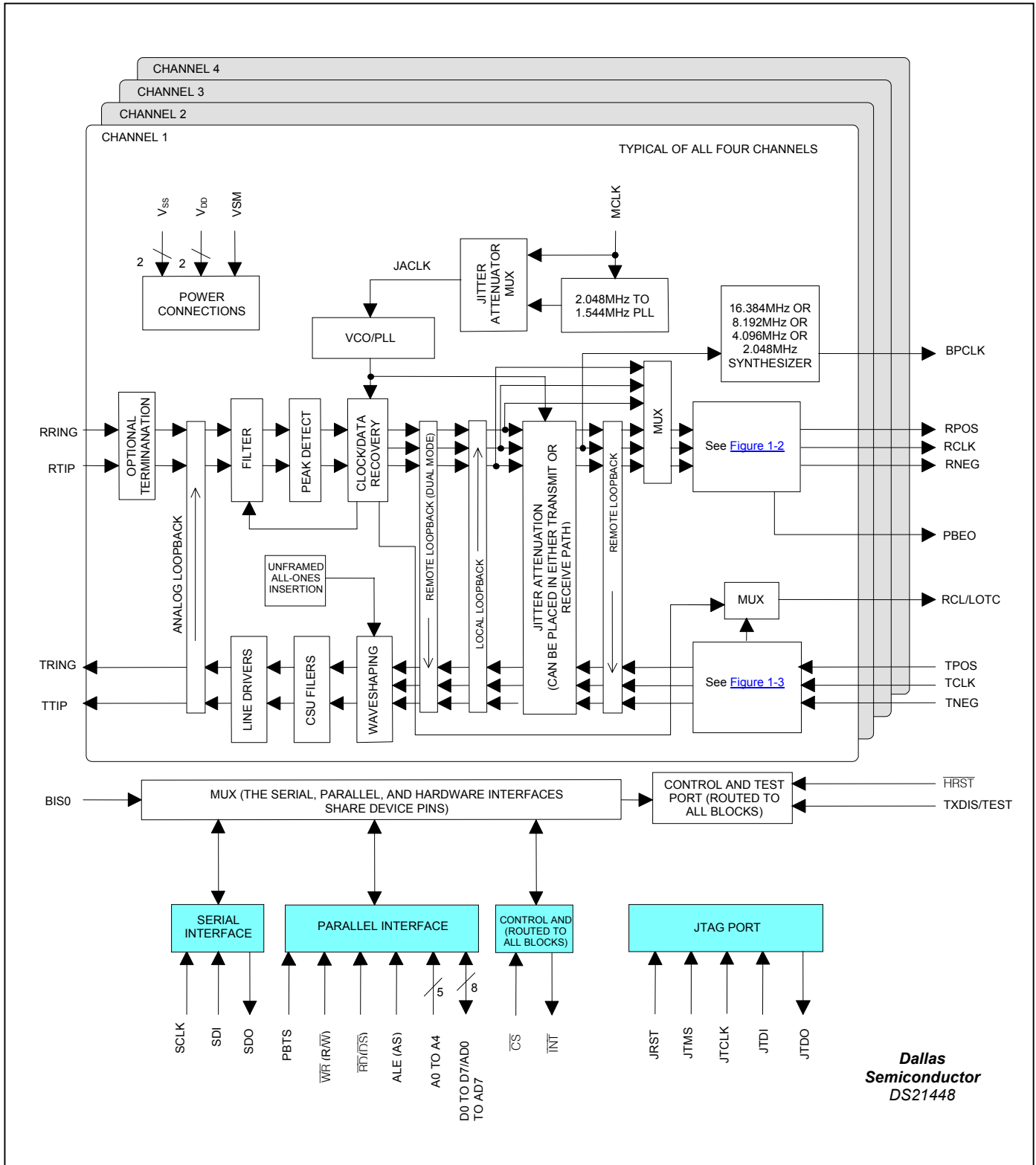



## 2. PIN DESCRIPTION

The DS21448 can be controlled in parallel port mode, serial port mode, or hardware mode. The bus interface select bits 0 and 1 (BIS0, BIS1) determine the device mode and pin assignments ([Table 2-A](#)).

**Table 2-A. Bus Interface Selection**

BIS1	BIS0	BUS INTERFACE TYPE
0	0	Parallel Port Mode (multiplexed)
0	1	Parallel Port Mode (nonmultiplexed)
1	0	Serial Port Mode
1	1	Hardware Mode

**Table 2-B. Pin Assignments**

PIN		I/O	PARALLEL PORT MODE	SERIAL PORT MODE	HARDWARE MODE
BGA	LQFP				
J3	18	I	$\overline{CS1}$	$\overline{CS1}$	EGL1
D3	57	I	$\overline{CS2}$	$\overline{CS2}$	EGL2
D10	84	I	$\overline{CS3}$	$\overline{CS3}$	EGL3
K10	114	I	$\overline{CS4}$	$\overline{CS4}$	EGL4
J2	91	I	$\overline{RD}$ ( $\overline{DS}$ )	N/A	ETS
H1	92	I	$\overline{WR}$ (R/W)	N/A	NRZE
K2	95	I	ALE (AS)	N/A	SCLKE
J1	35	I	N/A	SCLK	L2
K3	36	I	N/A	SDI	L1
K1	62	I/O	A4	SDO	L0
L1	63	I	A3	ICES	DJA
H11	64	I	A2	OCES	JAMUX
H12	65	I	A1	N/A	JAS
G12	66	I	A0	N/A	HBE
J10	75	I/O	D7/AD7	N/A	CES
H10	76	I/O	D6/AD6	N/A	TPD
G11	77	I/O	D5/AD5	N/A	TX0
J9	78	I/O	D4/AD4	N/A	TX1
E3	79	I/O	D3/AD3	N/A	LOOP0
D4	80	I/O	D2/AD2	N/A	LOOP1
F3	81	I/O	D1/AD1	N/A	MM0
D5	82	I/O	D0/AD0	N/A	MM1
—	3	I	VSM	VSM	VSM
L5	115–117	—	VDD1	VDD1	VDD1
E4	19–21	—	VDD2	VDD2	VDD2
D8	49–51	—	VDD3	VDD3	VDD3
J8	85–87	—	VDD4	VDD4	VDD4
M4	118–120	—	VSS1	VSS1	VSS1
F4	22–24	—	VSS2	VSS2	VSS2
D9	52–54	—	VSS3	VSS3	VSS3
H9	88–90	—	VSS4	VSS4	VSS4
K9	97	I/O	$\overline{INT}$	$\overline{INT}$	RT1
K5	110	O	PBEO1	PBEO1	PBEO1
G3	111	O	PBEO2	PBEO2	PBEO2
E10	121	O	PBEO3	PBEO3	PBEO3
K8	123	O	PBEO4	PBEO4	PBEO4
L6	126	O	RCL1/LOTC1	RCL1/LOTC1	RCL1
D7	128	O	RCL2/LOTC2	RCL2/LOTC2	RCL2
F9	1	O	RCL3/LOTC3	RCL3/LOTC3	RCL3
J7	2	O	RCL4/LOTC4	RCL4/LOTC4	RCL4
K7	98	I	TXDIS/TEST	TXDIS/TEST	TXDIS/TEST
A1	124	I	RTIP1	RTIP1	RTIP1
A4	28	I	RTIP2	RTIP2	RTIP2
A7	60	I	RTIP3	RTIP3	RTIP3
A10	93	I	RTIP4	RTIP4	RTIP4
B2	125	I	RRING1	RRING1	RRING1
B5	29	I	RRING2	RRING2	RRING2

PIN		I/O	PARALLEL PORT MODE	SERIAL PORT MODE	HARDWARE MODE
BGA	LQFP				
B8	61	I	RRING3	RRING3	RRING3
B11	94	I	RRING4	RRING4	RRING4
L9	106	I	HRST	HRST	HRST
J6	109	I	MCLK	MCLK	MCLK
H4	122	O	BPCLK1	BPCLK1	BPCLK1
D6	47	O	BPCLK2	BPCLK2	BPCLK2
F10	56	O	BPCLK3	BPCLK3	BPCLK3
L8	112	O	BPCLK4	BPCLK4	BPCLK4
L7	107	I	BIS0	BIS0	BIS0
M8	68	I	BIS1	BIS1	BIS1
A2	6	O	TTIP1	TTIP1	TTIP1
A5	38	O	TTIP2	TTIP2	TTIP2
A8	71	O	TTIP3	TTIP3	TTIP3
A11	102	O	TTIP4	TTIP4	TTIP4
J4	7	—	TVSS1	TVSS1	TVSS1
D1	39	—	TVSS2	TVSS2	TVSS2
E9	72	—	TVSS3	TVSS3	TVSS3
L10	103	—	TVSS4	TVSS4	TVSS4
J5	8	—	TVDD1	TVDD1	TVDD1
D2	40	—	TVDD2	TVDD2	TVDD2
G9	73	—	TVDD3	TVDD3	TVDD3
M9	104	—	TVDD4	TVDD4	TVDD4
B3	9	O	TRING1	TRING1	TRING1
B6	41	O	TRING2	TRING2	TRING2
B9	74	O	TRING3	TRING3	TRING3
B12	105	O	TRING4	TRING4	TRING4
K4	10	O	RPOS1	RPOS1	RPOS1
E1	12	O	RPOS2	RPOS2	RPOS2
D11	14	O	RPOS3	RPOS3	RPOS3
K11	16	O	RPOS4	RPOS4	RPOS4
G2	11	O	RNEG1	RNEG1	RNEG1
E2	13	O	RNEG2	RNEG2	RNEG2
F11	15	O	RNEG3	RNEG3	RNEG3
M10	25	O	RNEG4	RNEG4	RNEG4
H3	127	O	RCLK1	RCLK1	RCLK1
F1	31	O	RCLK2	RCLK2	RCLK2
E11	58	O	RCLK3	RCLK3	RCLK3
L11	96	O	RCLK4	RCLK4	RCLK4
G1	26	I	TPOS1	TPOS1	TPOS1
F2	30	I	TPOS2	TPOS2	TPOS2
E12	33	I	TPOS3	TPOS3	TPOS3
M11	55	I	TPOS4	TPOS4	TPOS4
H2	27	I	TNEG1	TNEG1	TNEG1
M1	32	I	TNEG2	TNEG2	TNEG2
D12	34	I	TNEG3	TNEG3	TNEG3
K12	59	I	TNEG4	TNEG4	TNEG4
M2	17	I	TCLK1	TCLK1	TCLK1
L2	43	I	TCLK2	TCLK2	TCLK2
F12	83	I	TCLK3	TCLK3	TCLK3
L12	113	I	TCLK4	TCLK4	TCLK4
M12	108	I	PBTS	N/A	RT0
L3	42	I	JTRST	JTRST	JTRST
M3	48	I	JTMS	JTMS	JTMS
M5	44	I	JTCLK	JTCLK	JTCLK
M6	45	I	JTDI	JTDI	JTDI
M7	46	O	JTDO	JTDO	JTDO

**Note 1:** The VSM signal is not available with the BGA package option.

**Note 2:** The LQFP no-connect pin numbers are 4, 5, 37, 67, 69, 70, and 99–101.

**Note 3:** The BGA no-connect pin numbers are A3, A6, A9, A12, B1, B4, B7, B10, C1–C12, E5–E8, F5–F8, G4–G8, G10, H5–H8, J11, J12, K6, and L4.

**Table 2-C. Parallel Interface Mode Pin Description**

PIN	I/O	FUNCTION
$\overline{RD}$ ( $\overline{DS}$ )	I	Read Input (Data Strobe). $\overline{RD}$ and $\overline{DS}$ are active-low signals. $\overline{DS}$ is active low when in nonmultiplexed, Motorola mode. See the bus timing diagrams in Section 10.
$\overline{WR}$ ( $\overline{RW}$ )	I	Write Input (Read/Write). $\overline{WR}$ is an active-low signal. See the bus timing diagrams in Section 10.
ALE (AS)	I	Address Latch Enable (Address Strobe). When using multiplexed bus mode (BIS0 = 0), this pin serves to demultiplex the bus on a positive-going edge. In nonmultiplexed bus mode (BIS0 = 1), ALE should be wired low.
A4–A0	I	Address Bus. In nonmultiplexed bus operation (BIS0 = 1), these pins serve as the address bus. In multiplexed bus operation (BIS0 = 0), these pins are not used and should be wired low.
D7/AD7–D0/AD0	I/O	Data Bus/Address/Data Bus. In nonmultiplexed bus operation (BIS0 = 1), these pins serve as the data bus. In multiplexed bus operation (BIS0 = 0), these pins serve as an 8-bit multiplexed address/data bus.
$\overline{INT}$	O	Interrupt ( $\overline{INT}$ ). The interrupt flags the host controller during conditions and change of conditions defined in the status register. It is an active-low, open-drain output.
TXDIS/TEST	I	Tri-State Control, Multifunctional. Set this pin high, with all $\overline{CS1}$ – $\overline{CS4}$ inputs inactive, to tri-state TTIP1–TTIP4 and TRING1–TRING4. Set this pin high with any of the $\overline{CS1}$ – $\overline{CS4}$ inputs active to tri-state all outputs and I/O pins (including the parallel control port). Set low for normal operation.
$\overline{HRST}$	I	Hardware Reset. Bringing $\overline{HRST}$ low resets the DS21448, setting all control bits to the all-zeros default state.
MCLK	I	Master Clock. A 2.048MHz ( $\pm 50$ ppm) clock source with TTL levels is applied at this pin. This clock is used internally for both clock/data recovery and for jitter attenuation. Use of a T1 1.544MHz clock source is optional (Note 1).
BIS0/BIS1	I	Bus Interface Select Bit 0 and 1. Used to select bus interface option. See Table 2-A for details.
PBTS	I	Parallel Bus Type Select. When using the parallel port, set PBTS high to select Motorola bus timing; set low to select Intel bus timing. This pin controls the function of the $\overline{RD}$ ( $\overline{DS}$ ), ALE (AS), and $\overline{WR}$ ( $\overline{RW}$ ) pins.
$\overline{CS1}$ – $\overline{CS4}$	I	Chip Select 1. Must be low to read or write to channel 1 of the device. $\overline{CS1}$ is an active-low signal.
		Chip Select 2. Must be low to read or write to channel 2 of the device. $\overline{CS2}$ is an active-low signal.
		Chip Select 3. Must be low to read or write to channel 3 of the device. $\overline{CS3}$ is an active-low signal.
		Chip Select 4. Must be low to read or write to channel 4 of the device. $\overline{CS4}$ is an active-low signal.
PBEO1–PBEO4	O	PRBS Bit-Error Output. The receiver constantly searches for a $2^{15} - 1$ (E1) or a QRSS (T1) PRBS, depending on the ETS bit setting (CCR1.7). It remains high if it is out of synchronization with the PRBS pattern. It goes low when synchronized to the PRBS pattern. Any errors in the received pattern after synchronization cause a positive-going pulse (with same period as E1 or T1 clock) synchronous with RCLK. PRBS bit errors can also be reported to the ECR1 and ECR2 registers by setting CCR6.2 to logic 1.
RCL1/LOT1–RCL4/LOT4	O	Receive Carrier Loss/Loss-of-Transmit Clock. An output that toggles high during a receive carrier loss (CCR2.7 = 0) or toggles high if the TCLK pin has not been toggled for $5\mu\text{s} \pm 2\mu\text{s}$ (CCR2.7 = 1). CCR2.7 defaults to logic 0 when in hardware mode.
RTIP1–RTIP4	I	Receive Tip and Ring. Analog inputs for clock recovery circuitry. These pins connect through a 1:1 transformer to the line. See Section 7 for details.
RRING1–RRING4	I	
BPCLK1–BPCLK4	O	Backplane Clock. A 16.384MHz, 8.192MHz, 4.096MHz, or 2.048MHz clock output that is referenced to RCLK selectable through CCR5.7 and CCR5.6.
TTIP1–TTIP4	O	Transmit Tip and Ring. Analog line-driver outputs. These pins connect through a step-up transformer to the line. See Section 7 for details.
TRING1–TRING4	O	
RPOS1–RPOS4	O	Receive Positive Data. These bits are updated on the rising edge (CCR2.0 = 0) or the falling edge (CCR2.0 = 1) of RCLK with bipolar data out of the line interface. Set NRZE (CCR1.6) to 1 for NRZ applications. In NRZ mode, data is output on RPOS, and a received error (BPV, CV, or EXZ) causes a positive-going pulse synchronous with RCLK at RNEG.
RNEG1–RNEG4	O	Receive Negative Data. Updated on the rising edge (CCR2.0 = 0) or the falling edge (CCR2.0 = 1) of RCLK with the bipolar data out of the line interface. Set NRZE (CCR1.6) to 1 for NRZ applications. In NRZ mode, data is output on RPOS, and a received error (BPV, CV, or EXZ) causes a positive-going pulse synchronous with RCLK at RNEG.

PIN	I/O	FUNCTION
RCLK1–RCLK4	O	Receive Clock. Buffered recovered clock from the line. Synchronous to MCLK in absence of signal at RTIP and RRING.
TPOS1–TPOS4	I	Transmit Positive Data. Sampled on the falling edge (CCR2.1 = 0) or the rising edge (CCR2.1 = 1) of TCLK for data to be transmitted out onto the line.
TNEG1–TNEG4	I	Transmit Negative Data. Sampled on the falling edge (CCR2.1 = 0) or the rising edge (CCR2.1 = 1) of TCLK for data to be transmitted out onto the line.
TCLK1–TCLK4	I	Transmit Clock. A 2.048MHz or 1.544MHz primary clock. It is used to clock data through the transmit-side formatter. It can be sourced internally by MCLK or RCLK. See Common Control Register 1 and <a href="#">Figure 1-3</a> .
JTRST	I	JTAG Reset
JTMS	I	JTAG Mode Select
JTCLK	I	JTAG Clock
JTDI	I	JTAG Data In
JTDO	O	JTAG Data Out
VSM	I	Voltage Supply Mode (LQFP only). Should be wired low for correct operation.
TVDD1–TVDD4	—	3.3V, ±5% Transmitter Positive Supply
VDD1–VDD4	—	3.3V, ±5% Positive Supply
TVSS1–TVSS4	—	Transmitter Signal Ground
VSS1–VSS4	—	Signal Ground

**Table 2-D. Serial Interface Mode Pin Description**

PIN	I/O	FUNCTION
$\overline{\text{INT}}$	I/O	Interrupt ( $\overline{\text{INT}}$ ). Flags host controller during conditions and change of conditions defined in the status register. Active-low, open-drain output.
TXDIS/TEST	I	Tri-State Control, Multifunctional. Set this pin high with all $\overline{\text{CS1}}\text{--}\overline{\text{CS4}}$ inputs inactive to tri-state TTIP1–TTIP4 and TRING1–TRING4. Set this pin high with any of the $\overline{\text{CS1}}\text{--}\overline{\text{CS4}}$ inputs active to tri-state all outputs and I/O pins (including the parallel control port). Set low for normal operation.
HRST	I	Hardware Reset. Bringing $\overline{\text{HRST}}$ low resets the DS21448, setting all control bits to the all-zeros default state.
MCLK	I	Master Clock. A 2.048MHz (±50ppm) clock source with TTL levels is applied at this pin. This clock is used internally for both clock/data recovery and for jitter attenuation. A T1 1.544MHz clock source is optional (Note 1).
BIS0/BIS1	I	Bus Interface Select Bit 0 and 1. Used to select bus interface option. See <a href="#">Table 2-A</a> for details.
$\overline{\text{CS1}}$	I	Chip Select 1. Must be low to read or write to channel 1 of the device. $\overline{\text{CS1}}$ is an active-low signal.
$\overline{\text{CS2}}$	I	Chip Select 2. Must be low to read or write to channel 2 of the device. $\overline{\text{CS2}}$ is an active-low signal.
$\overline{\text{CS3}}$	I	Chip Select 3. Must be low to read or write to channel 3 of the device. $\overline{\text{CS3}}$ is an active-low signal.
$\overline{\text{CS4}}$	I	Chip Select 4. Must be low to read or write to channel 4 of the device. $\overline{\text{CS4}}$ is an active-low signal.
ICES	I	Input Clock-Edge Select. Selects whether the serial interface data input (SDI) is sampled on the rising (ICES = 0) or falling edge (ICES = 1) of SCLK.
OCES	I	Output Clock-Edge Select. Selects whether the serial interface data output (SDO) changes on the rising (OCES = 1) or falling edge (OCES = 0) of SCLK.
SCLK	I	Serial Clock. Serial interface clock.
SDI	I	Serial Data Input. Serial interface data input.
SDO	O	Serial Data Output. Serial interface data output.
PBEO1–PBEO4	O	PRBS Bit-Error Output. The receiver constantly searches for a $2^{15} - 1$ (E1) or a QRSS (T1) PRBS, depending on the ETS bit setting (CCR1.7). It remains high if it is out of synchronization with the PRBS pattern. It goes low when synchronized to the PRBS pattern. Any errors in the received pattern after synchronization cause a positive-going pulse (with same period as E1 or T1 clock) synchronous with RCLK. PRBS bit errors can also be reported to the ECR1 and ECR2 registers by setting CCR6.2 to logic 1.
RCL1/LOT1–RCL4/LOT4	O	Receive Carrier Loss/Loss-of-Transmit Clock. An output that toggles high during a receive carrier loss (CCR2.7 = 0) or toggles high if the TCLK pin has not been toggled for $5\mu\text{s} \pm 2\mu\text{s}$ (CCR2.7 = 1). CCR2.7 defaults to logic 0 when in hardware mode.
RTIP1–RTIP4	I	Receive Tip and Ring. Analog inputs for clock recovery circuitry. These pins connect through a 1:1 transformer to the line. See <a href="#">Section 7</a> for details.
RRING1–RRING4		

PIN	I/O	FUNCTION
BPCLK1–BPCLK4	O	Backplane Clock. A 16.384MHz, 8.192MHz, 4.096MHz, or 2.048MHz clock output that is referenced to RCLK selectable through CCR5.7 and CCR5.6.
TTIP1–TTIP4	O	Transmit Tip and Ring. Analog line-driver outputs. These pins connect through a step-up transformer to the line. See Section 7 for details.
TRING–TRING4	O	
RPOS1–RPOS4	O	Receive Positive Data. Updated on the rising edge (CCR2.0 = 0) or the falling edge (CCR2.0 = 1) of RCLK with bipolar data out of the line interface. Set NRZE (CCR1.6) to 1 for NRZ applications. In NRZ mode, data is output on RPOS, and a received error (BPV, CV, or EXZ) causes a positive-going pulse synchronous with RCLK at RNEG.
RNEG1–RNEG4	O	Receive Negative Data. Updated on the rising edge (CCR2.0 = 0) or the falling edge (CCR2.0 = 1) of RCLK with the bipolar data out of the line interface. Set NRZE (CCR1.6) to 1 for NRZ applications. In NRZ mode, data is output on RPOS, and a received error (BPV, CV, or EXZ) causes a positive-going pulse synchronous with RCLK at RNEG.
RCLK1–RCLK4	O	Receive Clock. Buffered recovered clock from the line. Synchronous to MCLK in absence of signal at RTIP and RRING.
TPOS1–TPOS4	I	Transmit Positive Data. Sampled on the falling edge (CCR2.1 = 0) or the rising edge (CCR2.1 = 1) of TCLK for data to be transmitted out onto the line.
TNEG1–TNEG4	I	Transmit Negative Data. Sampled on the falling edge (CCR2.1 = 0) or the rising edge (CCR2.1 = 1) of TCLK for data to be transmitted out onto the line.
TCLK1–TCLK4	I	Transmit Clock. A 2.048MHz or 1.544MHz primary clock used to clock data through the transmit side formatter. They can be sourced internally by MCLK or RCLK. See Common Control Register 1 and Figure 1-3.
JTRST	I	JTAG Reset
JTMS	I	JTAG Mode Select
JTCLK	I	JTAG Clock
JTDI	I	JTAG Data In
JTDO	O	JTAG Data Out
VSM	I	Voltage Supply Mode (LQFP only). VSM should be wired low for correct operation.
TVDD1–TVDD4	—	3.3V, ±5% Transmitter Positive Supply
VDD1–VDD4	—	3.3V, ±5% Positive Supply
TVSS1–TVSS4	—	Transmitter Signal Ground for Transmitter Outputs
VSS1–VSS4	—	Signal Ground

**Table 2-E. Hardware Interface Mode Pin Description**

PIN	I/O	FUNCTION
ETS	I	E1/T1 Select 0 = E1 1 = T1
NRZE	I	NRZ Enable 0 = bipolar data at RPOS/RNEG and TPOS/TNEG 1 = NRZ data at RPOS and TPOS or TNEG; RNEG outputs a positive-going pulse when the device receives a BPV, CV, or EXZ.
SCLKE	I	Receive and Transmit Synchronization Clock Enable. SCLKE combines RSCLKE (CCR5.3) and TSCLKE (CCR5.2). 0 = disable 2.048MHz synchronization transmit and receive mode 1 = enable 2.048MHz synchronization transmit and receive mode
DJA	I	Disable Jitter Attenuator 0 = jitter attenuator enabled 1 = jitter attenuator disabled
JAMUX	I	Jitter Attenuator Clock Mux. Controls the source for JACLK. 0 = JACLK sourced from MCLK (2.048MHz or 1.544MHz at MCLK). 1 = JACLK sourced from internal PLL (2.048 MHz at MCLK).
JAS	I	Jitter Attenuator Path Select 0 = place the jitter attenuator on the receive side 1 = place the jitter attenuator on the transmit side
HBE	I	Receive and Transmit HDB3/B8ZS Enable. HBE combines RHBE (CCR2.3) and THBE (CCR2.2). 0 = enable HDB3 (E1)/B8ZS (T1) 1 = disable HDB3 (E1)/B8ZS (T1)
L0/L1/L2	I	Line Build-Out Select Bits 0, 1, and 2. These pins set the transmitter build-out; see (Table 7-A (E1) and Table 7-B (T1).

PIN	I/O	FUNCTION
CES	I	Receive and Transmit Clock Select. Selects which RCLK edge to update RPOS and RNEG and which TCLK edge to sample TPOS and TNEG. CES combines TCES and RCES. 0 = update RPOS/RNEG on rising edge of RCLK; sample TPOS/TNEG on falling edge of TCLK 1 = update RPOS/RNEG on falling edge of RCLK; sample TPOS/TNEG on rising edge of TCLK
TPD	I	Transmit Power-Down 0 = normal transmitter operation 1 = powers down the transmitter and tri-states TTIP and TRING pins
TX0/TX1	I	Transmit Data Source Select Bits 0 and 1. These inputs determine the source of the transmit data ( <a href="#">Table 4-B</a> ).
LOOP0/LOOP1	I	Loopback Select Bits 0 and 1. These inputs determine the active loopback mode ( <a href="#">Table 4-A</a> ).
MM0/MM1	I	Monitor Mode Select Bits 0 and 1. These inputs determine if the receive equalizer is in a monitor mode ( <a href="#">Table 4-D</a> ).
RT1/RT0	I	Receive LIU Termination Select Bits 0 and 1. These inputs determine the receive termination ( <a href="#">Table 4-E</a> ).
TEST	I	Tri-State Control. Set high to tri-state all outputs and I/O pins (including the parallel control port). Set low for normal operation. Useful in board-level testing.
$\overline{\text{HRST}}$	I	Hardware Reset. Bringing $\overline{\text{HRST}}$ low resets the DS21448, setting all control bits to the all-zero default state.
MCLK	I	Master Clock. A 2.048MHz ( $\pm 50\text{ppm}$ ) clock source with TTL levels is applied at this pin. This clock is used internally for both clock/data recovery and for jitter attenuation. A T1 1.544MHz clock source is optional (Note 1). See <a href="#">Table 4-F</a> for details.
BIS0/BIS1	I	Bus Interface Select Bit 0 and 1. Used to select bus interface option ( <a href="#">Table 2-A</a> ).
EGL1–EGL4	I	Receive Equalizer Gain-Limit Select. These bits control the sensitivity of the receive equalizers ( <a href="#">Table 4-C</a> ).
PBEO1–PBEO4	O	PRBS Bit-Error Output. The receiver constantly searches for a $2^{15} - 1$ PRBS (ETS = 0) or a QRSS PRBS (ETS = 1). The pattern is chosen automatically by the value of the ETS pin. It remains high if it is out of synchronization with the PRBS pattern. It goes low when synchronized to the PRBS pattern. Any errors in the received pattern after synchronization cause a positive-going pulse (with same period as E1 or T1 clock) synchronous with RCLK.
RCL1–RCL4	O	Receive Carrier Loss. An output that toggles high during a receive carrier loss.
RTIP1–RTIP4	I	Receive Tip and Ring. Analog inputs for clock recovery circuitry. These pins connect through a 1:1 transformer to the line. See <a href="#">Section 7</a> for details.
RRING1–RRING4	I	Receive Ring. Analog inputs for clock recovery circuitry. These pins connect through a 1:1 transformer to the line. See <a href="#">Section 7</a> for details.
BPCLK1–BPCLK4	O	Backplane Clock. A 16.384MHz clock output that is referenced to RCLK.
TTIP1–TTIP4	O	Transmit Tip and Ring. Analog line-driver outputs. These pins connect through a step-up transformer to the line. See <a href="#">Section 7</a> for details.
TRING1–TRING4		
RPOS1–RPOS4	O	Receive Positive Data. Updated on the rising edge (CES = 0) or the falling edge (CES = 1) of RCLK with bipolar data out of the line interface. In NRZ mode (NRZE = 1), data is output on RPOS, and a received error (BPV, CV, or EXZ) causes a positive-going pulse synchronous with RCLK at RNEG.
RNEG1–RNEG4	O	Receive Negative Data. Updated on the rising edge (CES = 0) or the falling edge (CES = 1) of RCLK with bipolar data out of the line interface. In NRZ mode (NRZE = 1), data is output on RPOS, and a received error (BPV, CV, or EXZ) causes a positive-going pulse synchronous with RCLK at RNEG.
RCLK1–RCLK4	O	Receive Clock. Buffered recovered clock from the line. Synchronous to MCLK in absence of signal at RTIP and RRING.
TPOS1–TPOS4	I	Transmit Positive Data. Sampled on the falling edge (CES = 0) or the rising edge (CES = 1) of TCLK for data to be transmitted out onto the line.
TNEG1–TNEG4	I	Transmit Negative Data. Sampled on the falling edge (CES = 0) or the rising edge (CES = 1) of TCLK for data to be transmitted out onto the line.
TCLK1–TCLK4	I	Transmit Clock. A 2.048MHz or 1.544MHz primary clock used to clock data through the transmit side formatter. It can be sourced internally by MCLK or RCLK. See Common Control Register 1 and <a href="#">Figure 1-3</a> .
JTRST	I	JTAG Reset
JTMS	I	JTAG Mode Select
JTCLK	I	JTAG Clock
JTDI	I	JTAG Data In
JTDO	O	JTAG Data Out
VSM	I	Voltage Supply Mode (LQFP only). VSM should be wired low for correct operation.
TVDD1–TVDD4	–	3.3V, $\pm 5\%$ Transmitter Positive Supply
VDD1–VDD4	–	3.3V, $\pm 5\%$ Positive Supply

PIN	I/O	FUNCTION
TVSS1–TVSS4	—	Transmitter Signal Ground for Transmitter Outputs
VSS1–VSS4	—	Signal Ground

**Note 1:** G.703 requires an accuracy of  $\pm 50$ ppm for T1 and E1. TR62411 and ANSI specs require  $\pm 32$ ppm accuracy for T1 interfaces.

### 3. DETAILED DESCRIPTION

The DS21448 has a usable receiver sensitivity of 0 to -43dB for E1 applications and 0 to -36dB for T1 that allows it to operate on 0.63mm (22AWG) cables up to 2.5km (E1) and 6000ft (T1) in length. The user has the option to use internal receive termination, software selectable for 75 $\Omega$ , 100 $\Omega$ , and 120 $\Omega$  applications, or external termination. The on-board crystal-less jitter attenuator can be placed in either the transmit or the receive data path, and requires only a 2.048MHz MCLK for both E1 and T1 applications (with the option of using a 1.544MHz MCLK in T1 applications).

The DS21448 has diagnostic capabilities such as loopbacks and PRBS pattern generation and detection. 16-bit loop-up and loop-down codes can be generated and detected. A single input pin can power down all transmitters to allow the implementation of hitless protection switching (HPS) for 1+1 redundancy without the use of relays. The device can be controlled through an 8-bit parallel port (muxed or nonmuxed) or a serial port, and it can be used in hardware mode. A standard boundary scan interface supports board-level testing.

The DS21448 contains four independent LIUs that share a common interface for configuration and status. The user can choose between three different means of accessing the device: a parallel microprocessor interface, a serial interface, and a hardwired mode, which configures the device by setting levels on the device's pins. The DS21448's four chip selects ( $\overline{CS1}$ ,  $\overline{CS2}$ ,  $\overline{CS3}$ , and  $\overline{CS4}$ ) determine which LIU is accessed when using the parallel or serial interface modes. Four sets of identical register maps exist, one for each channel. Using the appropriate chip select accesses a channel's register map.

The analog AMI/HDB3 waveform off the E1 line or the AMI/B8ZS waveform off the T1 line is transformer-coupled into the RTIP and RRING pins of the DS21448. The user has the option to use internal termination, software selectable for 75 $\Omega$ /100 $\Omega$ /120 $\Omega$  applications, or external termination. The device recovers clock and data from the analog signal and passes it through the jitter attenuation mux, outputting the received line clock at RCLK and bipolar or NRZ data at RPOS and RNEG. The DS21448 contains an active filter that reconstructs the analog-received signal for the nonlinear losses that occur in transmission. The receive circuitry is also configurable for various monitor applications. The device has a usable receive sensitivity of 0 to -43dB for E1 and 0 to -36dB for T1 that allows the device to operate on 0.63mm (22AWG) cables up to 2.5km (E1) and 6k feet (T1) in length. Data input at TPOS and TNEG is sent through the jitter attenuation mux to the waveshaping circuitry and line driver. The DS21448 drives the E1 or T1 line from the TTIP and TRING pins through a coupling transformer. The line driver can handle both CEPT 30/ISDN-PRI lines for E1 and long-haul (CSU) or short-haul (DSX-1) lines for T1.

#### 3.1 DS21448 and DS21Q348 Differences

The DS21448 BGA is a monolithic quad-port LIU that is a replacement for the DS21Q348. The additional features of JTAG, transmit driver disable, and the serial interface in the DS21448 have changed the function of several pins, as shown in [Table 3-A](#).

**Table 3-A. DS21448 vs. DS21Q348 Pin Differences**

PIN	DS21Q348	DS21448
G4	VSM	N.C.
J1	VSS	SCLK
K1	A4	A4/SDO
K3	VSS	SDI
K7	TEST	TXDIS/TEST
L3	N.C.	JTRST*
M3	N.C.	JTMS*
M5	N.C.	JTCLK
M6	N.C.	JTDI*
M7	N.C.	JTDO

\*DS21448 pin is internally pulled up.

## 4. PORT OPERATION

### 4.1 Hardware Mode

The DS21448 supports a hardware configuration mode that allows the user to configure the device by setting levels on the device's pins. This mode allows the DS21448 configuration without the use of a microprocessor, simplifying designs. Not all of the device features are supported in the hardware mode.

In hardware mode (BIS0 = 1, BIS1 = 1) several pins have been redefined so they can be used for initializing the DS21448. Refer to [Table 2-B](#) and [Table 2-E](#) for pin assignment and definition. Because of limited pin count, several functions have been combined and affect all four channels in the device and/or treat the receive and transmit paths as one block. Restrictions when using the hardware mode include the following:

- BPCLK pins only output a 16.384MHz signal.
- The RCL/LOT pins are designated to RCL.
- The RHBE and THBE control bits are combined and controlled by HBE.
- RSCLKE and TSCLKE bits are combined and controlled by SCLKE.
- TCES and RCES are combined and controlled by CES.
- The transmitter functions are combined and controlled by TX1 and TX0.
- Loopback functions are controlled by LOOP1 and LOOP0.
- JABDS defaults to 128-bit buffer depth.
- All other control bits default to logic 0.

**Table 4-A. Loopback Control in Hardware Mode**

LOOPBACK	SYMBOL	LOOP1	LOOP0
Remote Loopback	RLB	1	1
Local Loopback	LLB	1	0
Analog Loopback	ALB	0	1
No Loopback	—	0	0

**Table 4-B. Transmit Data Control in Hardware Mode**

TRANSMIT DATA	SYMBOL	TX1	TX0
Unframed All Ones	TUA1	1	1
Alternating Ones and Zeros	TAOZ	1	0
PRBS	TPRBSE	0	1
TPOS and TNEG	—	0	0

**Table 4-C. Receive Sensitivity Settings in Hardware Mode**

EGL	ETS	RECEIVE SENSITIVITY (dB)
0	0 (E1)	-12 (short haul)
1	0 (E1)	-43 (long haul)
1	1 (T1)	-30 (limited long haul)
0	1 (T1)	-36 (long haul)

**Table 4-D. Monitor Gain Settings in Hardware Mode**

MM1	MM0	INTERNAL LINEAR GAIN BOOST (dB)
0	0	Normal operation (no boost)
0	1	20
1	0	26
1	1	32

**Table 4-E. Internal Rx Termination Select in Hardware Mode**

RT1	RT0	INTERNAL RECEIVE TERMINATION CONFIGURATION
0	0	Internal receive-side termination disabled
0	1	Internal receive-side 120Ω enabled
1	0	Internal receive-side 100Ω enabled
1	1	Internal receive-side 75Ω enabled

**Table 4-F. MCLK Selection in Hardware Mode**

MCLK (MHz)	JAMUX	ETS
2.048	0	0
2.048	1	1
1.544	0	1

## 4.2 Serial Port Operation

Setting BIS1 = 1 and BIS0 = 0 enables the serial bus interface on the DS21448 ([Table 2-A](#)). Serial port read/write timing is unrelated to the system transmit and receive timing, allowing asynchronous reads or writes by the host. See [Section 10](#) for the AC timing of the serial port. All serial port accesses are LSB first. See [Figure 4-1](#), [Figure 4-2](#), [Figure 4-3](#), [Figure 4-4](#), [Figure 4-5](#), and [Figure 4-6](#) for additional details.

A serial bus access requires the use of four signals: serial clock (SCLK), one of the four chip selects ( $\overline{CS}$ ), serial data input (SDI), and serial data output (SDO). The DS21448 uses SCLK to sample data that is present on SDI and output data onto SDO. Input clock-edge select (ICES) allows the user to choose which SCLK edge input data is sampled on. Output clock-edge select (OCES) allows the user to choose which SCLK edge output data changes on. When ICES is low, input data is latched on the rising edge of SCLK, and when ICES is high, input data is latched on the falling edge of SCLK. When OCES is low, data is output on the falling edge of SCLK, and when OCES is high, data is output on the rising edge of SCLK. Data is held until the next falling or rising edge of SCLK. All data transfers are initiated by driving the appropriate port's  $\overline{CS}$  input low and ends with  $\overline{CS}$  going inactive.  $\overline{CS}$  must go inactive between data transfers. See the serial bus timing information in [Section 10](#) for details. All data transfers are terminated if the port's  $\overline{CS}$  input transitions high. Port control logic is disabled, and SDO is tri-stated when all  $\overline{CS}$  pins are inactive.

Reading from or writing to the internal registers requires writing one address/command byte prior to the transferring register data. Two types of serial bus transfers exist, standard and burst. The standard serial bus access always consists of two bytes, an address/command byte that is always supplied by the user on SDI, and a data byte that can either be written to the DS21448 using SDI (write operation) or output by the DS21448 on SDO (read operation). The burst serial bus access consists of a single address/command byte followed either by 22 read or 22 write data bytes.

The first bit written (LSB) of the address/command byte specifies whether the access is to be a read (1) or a write (0). The next 5 bits identify the register address. Valid register addresses are 00h through 15h. Bit 7 is reserved and must be set to 0 for proper operation. Bit 8, the last bit (MSB) of the address/command byte, is the burst mode-enable bit. When the burst bit is enabled (set to 0) and a READ operation is performed, the DS21448 automatically outputs the contents of registers 00h through 15h sequentially, starting with register address 00h. When the burst bit is enabled and a WRITE operation is performed, data supplied on SDI is sequentially written into the DS21448's register space starting at address 00h. Burst operation is stopped once address 15h is read or  $\overline{CS}$  goes inactive. For both burst read and burst write transfers, the address/command byte's register address bits must be set to 0.

The user can broadcast register write accesses to multiple ports simultaneously by enabling the desired channels' chip selects at the same time. However, only one port can be read at a time. Any attempt to read multiple ports simultaneously results in invalid data being returned on SDO.

**Figure 4-1. Serial Port Operation for Read Access (R = 1) Mode 1**

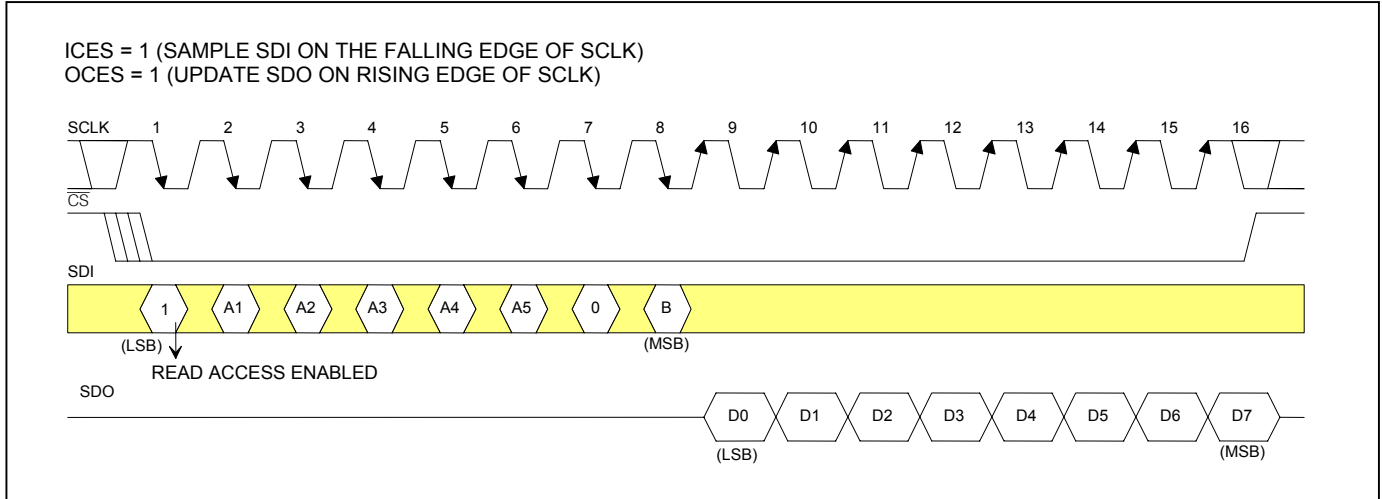

**Figure 4-2. Serial Port Operation for Read Access (R = 1) Mode 2**

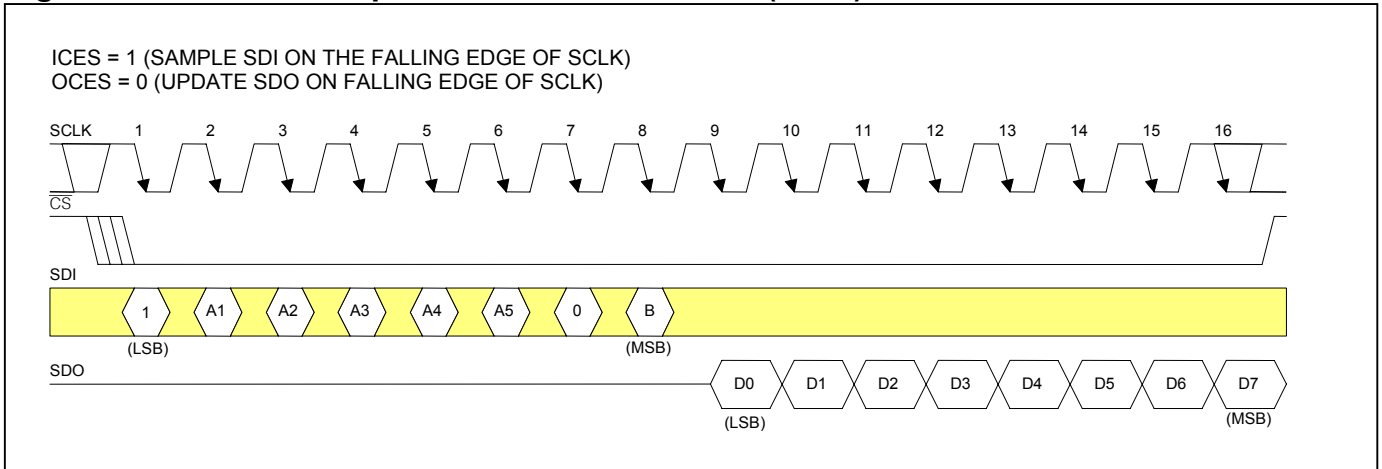

**Figure 4-3. Serial Port Operation for Read Access (R = 1) Mode 3**

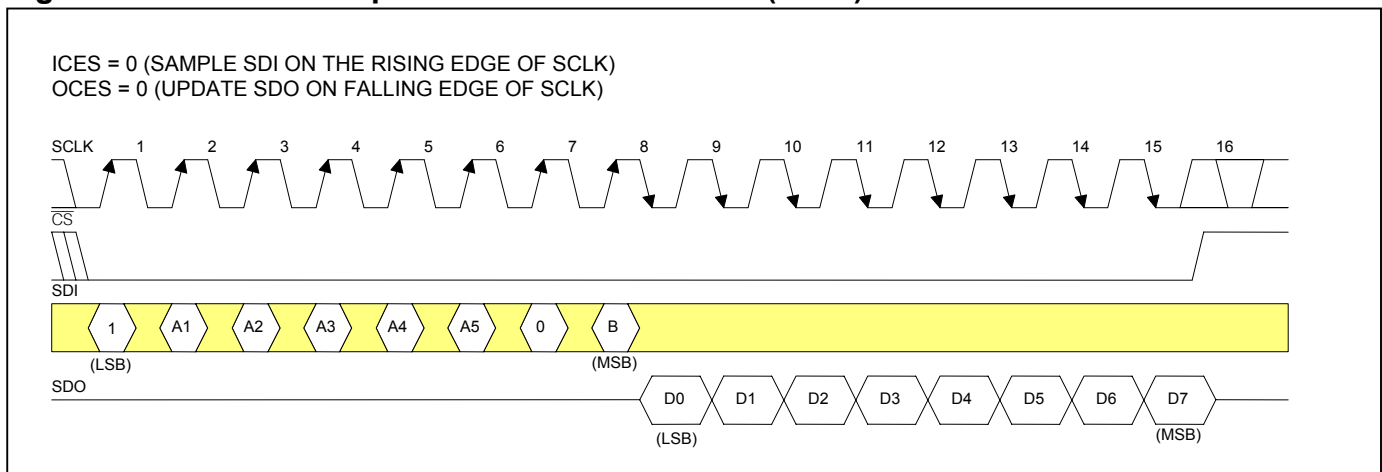

**Figure 4-4. Serial Port Operation for Read Access (R = 1) Mode 4**

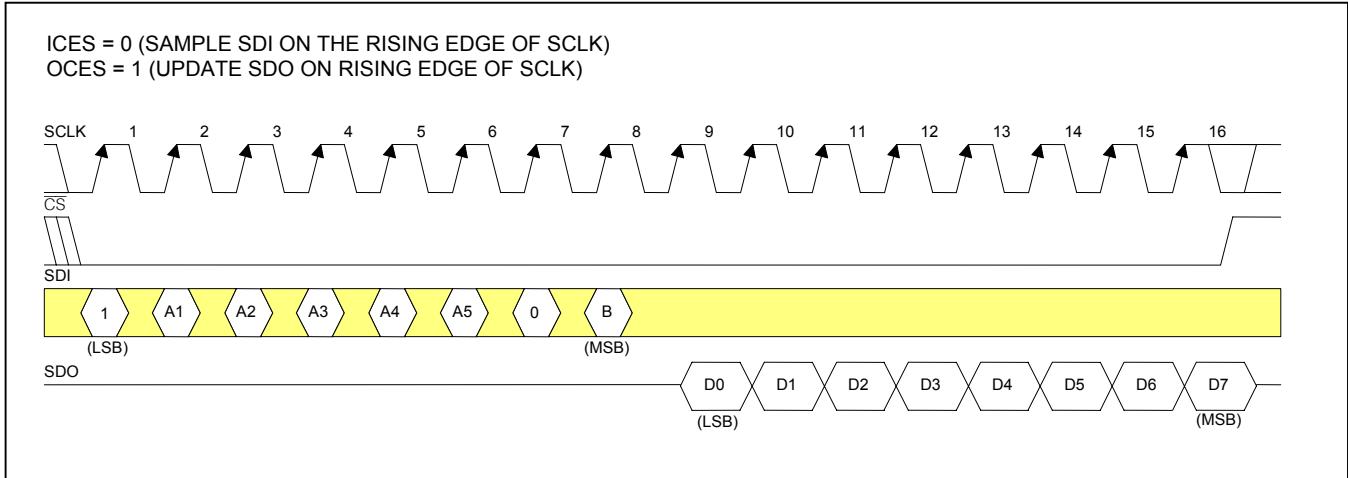

**Figure 4-5. Serial Port Operation for Write Access (R = 0) Modes 1 and 2**

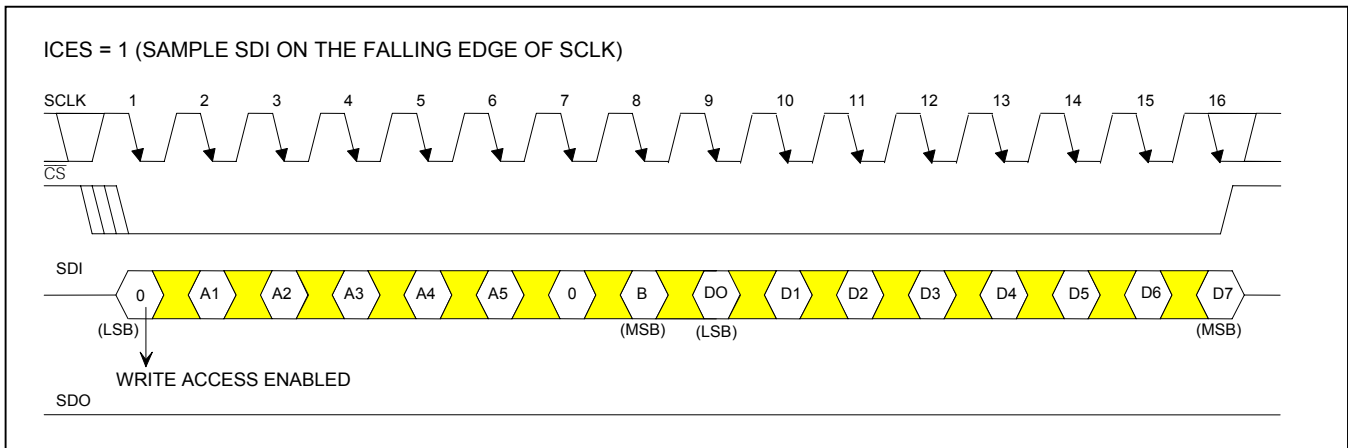

**Figure 4-6. Serial Port Operation for Write Access (R = 0) Modes 3 and 4**

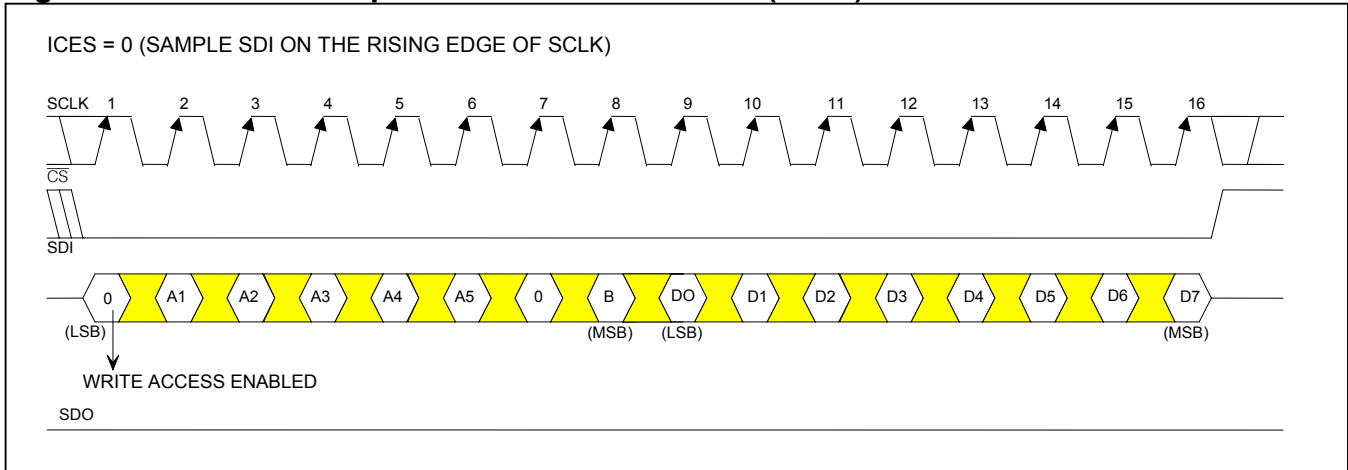

### 4.3 Parallel Port Operation

The option for either multiplexed bus operation (BIS0 = 0) or nonmultiplexed bus operation (BIS0 = 1) is available when using the parallel interface. The DS21448 can operate with either Intel or Motorola bus timing configurations. If the PBTS pin is wired low, Intel timing is selected; if wired high, Motorola timing is selected. All Motorola bus signals are listed in parentheses (). Four sets of identical register maps exist, one for each channel. See [Table 4-H](#) for register names and addresses. Use the appropriate chip select ( $\overline{CS1}$ ,  $\overline{CS2}$ ,  $\overline{CS3}$ , or  $\overline{CS4}$ ) to access a channel's register map. See the timing diagrams in Section [10](#) for more details. Hardware and serial port modes are not supported when using parallel port operation.

#### 4.3.1 Device Power-Up and Reset

The DS21448 resets itself upon power-up, setting all writeable registers to 00h and clearing the status and information registers. CCR3.7 (TUA1) = 0 results in the LIU transmitting unframed all ones. After the power supplies have settled, initialize all control registers to the desired settings, then toggle the LIRST bit (CCR3.2). The DS21448 can at any time be reset to the default settings by bringing  $\overline{HRST}$  low (level triggered) or by powering down and powering up again.

**Table 4-G. Parallel Port Mode Selection**

PBTS	BIS0	PROCESSOR	BUS INTERFACE TYPE
0	0	Intel	Parallel Port Mode (Multiplexed)
0	1	Intel	Parallel Port Mode (Nonmultiplexed)
1	0	Motorola	Parallel Port Mode (Multiplexed)
1	1	Motorola	Parallel Port Mode (Nonmultiplexed)

#### 4.3.2 Register Map

[Table 4-H](#) shows the typical register map for all four ports. Use the appropriate chip select ( $\overline{CS1}$ ,  $\overline{CS2}$ ,  $\overline{CS3}$ , or  $\overline{CS4}$ ) to access a channel's register map.

**Table 4-H. Register Map**

NAME	R/W	ADDRESS	FUNCTION
CCR1	R/W	00h	Common Control Register 1
CCR2	R/W	01h	Common Control Register 2
CCR3	R/W	02h	Common Control Register 3
CCR4	R/W	03h	Common Control Register 4
CCR5	R/W	04h	Common Control Register 5
CCR6	R/W	05h	Common Control Register 6
SR	R	06h	Status Register
IMR	R/W	07h	Interrupt Mask Register
RIR1	R	08h	Receive Information Register 1
RIR2	R	09h	Receive Information Register 2
IBCC	R/W	0Ah	In-Band Code Control Register
TCD1	R/W	0Bh	Transmit Code Definition Register 1
TCD2	R/W	0Ch	Transmit Code Definition Register 2
RUPCD1	R/W	0Dh	Receive-Up Code Definition Register 1
RUPCD2	R/W	0Eh	Receive-Up Code Definition Register 2
RDNCD1	R/W	0Fh	Receive-Down Code Definition Register 1
RDNCD2	R/W	10h	Receive-Down Code Definition Register 2
ECR1	R	11h	Error Count Register 1
ECR2	R	12h	Error Count Register 2
TEST1	R/W	13h	Test 1
TEST2	R/W	14h	Test 2
TEST2	R/W	15h	Test 3
—	—	(Note 1)	—

**Note 1:** Register addresses 16h–1Fh do not exist.

### 4.3.3 Control Registers

#### CCR1 (00H): Common Control Register 1 (MSB)

(LSB)

ETS	NRZE	RCLA	ECUE	JAMUX	TTOJ	TTOR	LOTCMC
-----	------	------	------	-------	------	------	--------

NAME	POSITION	FUNCTION
ETS	CCR1.7	E1/T1 Select 0 = E1 1 = T1
NRZE	CCR1.6	NRZ Enable 0 = bipolar data at RPOS/RNEG and TPOS/TNEG 1 = NRZ data at RPOS and TPOS or TNEG; RNEG outputs a positive-going pulse when the device receives a BPV, CV, or EXZ
RCLA	CCR1.5	Receive-Carrier-Loss Alternate Criteria 0 = RCL declared upon 255 (E1) or 192 (T1) consecutive zeros 1 = RCL declared upon 2048 (E1) or 1544 (T1) consecutive zeros
ECUE	CCR1.4	Error Counter Update Enable. A 0-to-1 transition forces the next receive clock cycle to load the error counter registers with the latest counts and reset the counters. The user must wait a minimum of two clock cycles (976ns for E1 and 1296ns for T1) before reading the error count registers to allow for a proper update. See Section 6 for details.
JAMUX	CCR1.3	Jitter Attenuator Clock Mux. Controls the source for JACLK ( <a href="#">Figure 1-1</a> ). 0 = JACLK sourced from MCLK (2.048MHz or 1.544MHz at MCLK) 1 = JACLK sourced from internal PLL (2.048MHz at MCLK)
TTOJ	CCR1.2	TCLK to JACLK. Internally connects TCLK to JACLK ( <a href="#">Figure 1-3</a> ). 0 = disabled 1 = enabled
TTOR	CCR1.1	TCLK to RCLK. Internally connects TCLK to RCLK ( <a href="#">Figure 1-3</a> ). 0 = disabled 1 = enabled
LOTCMC	CCR1.0	Loss-of-Transmit Clock Mux Control. Determines whether the transmit logic should switch to JACLK if the TCLK input should fail to transition ( <a href="#">Figure 1-3</a> ). 0 = do not switch to JACLK if TCLK stops 1 = switch to JACLK if TCLK stops

**CCR2 (01H): Common Control Register 2****(MSB)****(LSB)**

RLPIN	—	SCLD	CLDS	RHBE	THBE	TCES	RCES
-------	---	------	------	------	------	------	------

NAME	POSITION	FUNCTION
RLPIN	CCR2.7	RCL/LOTC Pin Function Select. Forced to logic 0 in hardware mode. 0 = toggles high during a receive-carrier loss condition 1 = toggles high if TCLK does not transition for at least 5 $\mu$ s
—	CCR2.6	Not Assigned. Should be set to 0 when written to.
SCLD	CCR2.5	Short Circuit-Limit Disable (ETS = 0). Controls the 50mA (RMS) current limiter. 0 = enable 50mA current limiter 1 = disable 50mA current limiter
CLDS	CCR2.4	Custom Line-Driver Select. Setting this bit to 1 redefines the operation of the transmit line driver. When this bit is set to 1 and CCR4.5 = CCR4.6 = CCR4.7 = 0, the device generates a square wave at the TTIP and TRING outputs instead of a normal waveform. When this bit is set to 1 and CCR4.5 = CCR4.6 = CCR4.7 $\neq$ 0, the device forces TTIP and TRING outputs to become open-drain drivers instead of their normal push-pull operation. This bit should be set to 0 for normal operation of the device. Contact the factory for more details about how to use this bit.
RHBE	CCR2.3	Receive HDB3/B8ZS Enable 0 = enable HDB3 (E1)/B8ZS (T1) 1 = disable HDB3 (E1)/B8ZS (T1)
THBE	CCR2.2	Transmit HDB3/B8ZS Enable 0 = enable HDB3 (E1)/B8ZS (T1) 1 = disable HDB3 (E1)/B8ZS (T1)
TCES	CCR2.1	Transmit Clock-Edge Select. Selects which TCLK edge to sample TPOS and TNEG. 0 = sample TPOS and TNEG on falling edge of TCLK 1 = sample TPOS and TNEG on rising edge of TCLK
RCES	CCR2.0	Receive Clock-Edge Select. Selects which RCLK edge to update RPOS and RNEG. 0 = update RPOS and RNEG on rising edge of RCLK 1 = update RPOS and RNEG on falling edge of RCLK

**CCR3 (02H): Common Control Register 3****(MSB)****(LSB)**

TUA1	ATUA1	TAOZ	TPRBSE	TLCE	LIRST	IBPV	IBE
------	-------	------	--------	------	-------	------	-----

NAME	POSITION	FUNCTION
TUA1	CCR3.7	Transmit Unframed All Ones. The polarity of this bit is set such that the device transmits an all-ones pattern on power-up or device reset. This bit must be set to 1 to allow the device to transmit data. The transmission of this data pattern is always timed off JACLK ( <a href="#">Figure 1-1</a> ). 0 = transmit all ones at TTIP and TRING 1 = transmit data normally
ATUA1	CCR3.6	Automatic Transmit Unframed All Ones. Automatically transmit an unframed all-ones pattern at TTIP and TRING during an RCL condition. 0 = disabled 1 = enabled
TAOZ	CCR3.5	Transmit Alternate Ones and Zeros. Transmit a ...101010... pattern at TTIP and TRING. The transmission of this data pattern is always timed off TCLK. 0 = disabled 1 = enabled
TPRBSE	CCR3.4	Transmit PRBS Enable. Transmit a $2^{15} - 1$ (E1) or a QRSS (T1) PRBS at TTIP and TRING. 0 = disabled 1 = enabled
TLCE	CCR3.3	Transmit Loop-Code Enable. Enables the transmit side to transmit the loop-up code in the transmit code definition registers (TCD1 and TCD2). See Section <a href="#">6</a> for details. 0 = disabled 1 = enabled
LIRST	CCR3.2	Line Interface Reset. Setting this bit from 0 to 1 initiates an internal reset that resets the clock recovery state machine and recenters the jitter attenuator. Normally this bit is only toggled on power-up. It must be cleared and set again for a subsequent reset.
IBPV	CCR3.1	Insert Bipolar Violation (BPV). A 0-to-1 transition on this bit causes a single bipolar violation to be inserted into the transmit data stream. Once this bit has been toggled from 0 to 1, the device waits for the next occurrence of three consecutive 1s to insert the BPV. This bit must be cleared and set again for a subsequent error to be inserted ( <a href="#">Figure 1-3</a> ).
IBE	CCR3.0	Insert Bit Error. A 0-to-1 transition on this bit causes a single logic error to be inserted into the transmit data stream. This bit must be cleared and set again for a subsequent error to be inserted ( <a href="#">Figure 1-3</a> ).

**CCR4 (03H): Common Control Register 4****(MSB)****(LSB)**

L2	L1	L0	EGL	JAS	JABDS	DJA	TPD
----	----	----	-----	-----	-------	-----	-----

NAME	POSITION	FUNCTION
L2	CCR4.7	Line Build-Out Select Bit 2. Sets the transmitter build-out ( <a href="#">Table 7-A</a> for E1, <a href="#">Table 7-B</a> for T1).
L1	CCR4.6	Line Build Out Select Bit 1. Sets the transmitter build-out ( <a href="#">Table 7-A</a> for E1, <a href="#">Table 7-B</a> for T1).
L0	CCR4.5	Line Build Out Select Bit 0. Sets the transmitter build-out ( <a href="#">Table 7-A</a> for E1, <a href="#">Table 7-B</a> for T1).
EGL	CCR4.4	Receive Equalizer Gain Limit. This bit controls the sensitivity of the receive equalizer ( <a href="#">Table 4-1</a> ).
JAS	CCR4.3	Jitter Attenuator Path Select 0 = place the jitter attenuator on the receive side 1 = place the jitter attenuator on the transmit side
JABDS	CCR4.2	Jitter Attenuator Buffer Depth Select 0 = 128 bits 1 = 32 bits (use for delay-sensitive applications)
DJA	CCR4.1	Disable Jitter Attenuator 0 = jitter attenuator enabled 1 = jitter attenuator disabled
TPD	CCR4.0	Transmit Power-Down 0 = normal transmitter operation 1 = powers down the transmitter and tri-states the TTIP and TRING pins

**Table 4-I. Receive Sensitivity Settings**

EGL (CCR4.4)	ETS (CCR1.7)	RECEIVE SENSITIVITY (dB)
0	0 (E1)	-12 (short haul)
1	0 (E1)	-43 (long haul)
1	1 (T1)	-30 (limited long haul)
0	1 (T1)	-36 (long haul)

**CCR5 (04H): Common Control Register 5**  
(MSB)

							(LSB)
BPCS1	BPCS0	MM1	MM0	RSCLKE	TSCLKE	RT1	RT0

NAME	POSITION	FUNCTION
BPCS1	CCR5.7	Backplane Clock Frequency Select 1. See <a href="#">Table 4-J</a> for details.
BPCS0	CCR5.6	Backplane Clock Frequency Select 0. See <a href="#">Table 4-J</a> for details.
MM1	CCR5.5	Monitor Mode Gain Select 1 ( <a href="#">Table 4-K</a> .)
MM0	CCR5.4	Monitor Mode Gain Select 0. See ( <a href="#">Table 4-K</a> .)
RSCLKE	CCR5.3	Receive Synchronization Clock Enable 0 = disable 2.048MHz synchronization receive mode 1 = enable 2.048MHz synchronization receive mode
TSCLKE	CCR5.2	Transmit Synchronization Clock Enable 0 = disable 2.048MHz transmit synchronization clock 1 = enable 2.048MHz transmit synchronization clock
RT1	CCR5.1	Receive Termination Select 1. See <a href="#">Table 4-L</a> for details.
RT0	CCR5.0	Receive Termination Select 0. See <a href="#">Table 4-L</a> for details.

**Table 4-J. Backplane Clock Select**

BPCS1 (CCR5.7)	BPCS0 (CCR5.6)	BPCLK FREQUENCY (MHz)
0	0	16.384
0	1	8.192
1	0	4.096
1	1	2.048

**Table 4-K. Monitor Gain Settings**

MM1 (CCR5.5)	MM0 (CCR5.4)	INTERNAL LINEAR GAIN BOOST (dB)
0	0	Normal operation (no boost)
0	1	20
1	0	26
1	1	32

**Table 4-L. Internal Rx Termination Select**

RT1 (CCR5.1)	RT0 (CCR5.0)	INTERNAL RECEIVE TERMINATION CONFIGURATION
0	0	Internal receive-side termination disabled
0	1	Internal receive-side 120Ω enabled
1	0	Internal receive-side 100Ω enabled
1	1	Internal receive-side 75Ω enabled

**CCR6 (05H): Common Control Register 6****(MSB)****(LSB)**

LLB	RLB	ARLBE	ALB	RJAB	ECRS2	ECRS1	ECRS0
-----	-----	-------	-----	------	-------	-------	-------

NAME	POSITION	FUNCTION
LLB	CCR6.7	Local Loopback. In local loopback, transmit data is looped back to the receive path, passing through the jitter attenuator if it is enabled. Data in the transmit path acts as normal. See Section <a href="#">6.2</a> for details. 0 = loopback disabled 1 = loopback enabled
RLB	CCR6.6	Remote Loopback. In remote loopback, data output from the clock/data recovery circuitry is looped back to the transmit path, passing through the jitter attenuator if it is enabled. Data in the receive path acts as normal, while data presented at TPOS and TNEG is ignored. See Section <a href="#">6.2</a> for details. 0 = loopback disabled 1 = loopback enabled
ARLBE	CCR6.5	Automatic Remote Loopback Enable and Reset. When this bit is set high, the device automatically goes into remote loopback when it detects loop-up code programmed into the receive loop-up code definition registers (RUPCD1 and RUPCD2) for a minimum of 5 seconds; it also sets the RIR2.1 status bit. Once it is in an RLB state, the bit remains in this state until it has detected the loop code programmed into the receive loop-down code definition registers (RDNCD1 and RDNCD2) for a minimum of 5 seconds, at which point it forces the device out of RLB and clears RIR2.1. Toggling this bit from 1 to 0 resets the automatic RLB circuitry. The action of the automatic remote loopback circuitry is logically ORed with the RLB (CCR6.6) control bit (i.e., either one can cause a RLB to occur).
ALB	CCR6.4	Analog Loopback. In analog loopback, signals at TTIP and TRING are internally connected to RTIP and RRING. The incoming line signals at RTIP and RRING are ignored. The signals at TTIP and TRING are transmitted as normal. See Section <a href="#">6.2</a> for more details. 0 = loopback disabled 1 = loopback enabled
RJAB	CCR6.3	RCLK Jitter Attenuator Bypass. This control bit allows the receive-recovered clock and data to bypass the jitter attenuation, while still allowing the BPCLK output to use the jitter attenuator. See Section <a href="#">7.3</a> for details. 0 = disabled 1 = enabled
ECRS2	CCR6.2	Error Count Register Select 2. See Section <a href="#">6.4</a> for details.
ECRS1	CCR6.1	Error Count Register Select 1. See Section <a href="#">6.4</a> for details.
ECRS0	CCR6.0	Error Count Register Select 0. See Section <a href="#">6.4</a> for details.

**5. STATUS REGISTERS**

The three registers that contain information about the device's real-time status are the status register (SR) and receive information registers 1 and 2 (RIR1/RIR2). When a particular event has occurred (or is occurring), the appropriate bit in one of these registers is set to 1. Some bits in SR, RIR1, and RIR2 are latched bits and some are real-time bits (denoted in the following register descriptions). For latched status bits, when an event or an alarm occurs, the bit is set to 1 and remains set until the user reads that bit. The bit is cleared when it is read, and it is not set until the event has occurred again. Two of the latched status bits (RUA1 and RCL) remain set after reading if the alarm is still present.

The user always precedes a read of any of the three status registers with a write. The byte written to the register informs the DS21448 which bits the user wishes to read and have cleared. The user writes a byte to one of these registers with a 1 in the bit positions to be read and a 0 in the other bit positions. When a 1 is written to a bit location, that location is updated with the latest information. When a 0 is written to a bit position, that bit position is not updated, and the previous value is held. A write to the status and information registers is immediately followed by a read of the same register. The read result should be logically ANDed with the mask byte that was just written, and this value should be written back into the same register to ensure that bit does indeed clear. This second write step is necessary because the alarms and events in the status registers occur asynchronously with respect to their access through the parallel port. This write-read-write scheme allows an external microcontroller or microprocessor to individually poll certain bits without disturbing the other bits in the register. This operation is key in controlling the DS21448 with higher-order software languages.

The bits in the SR register have the unique ability to initiate a hardware interrupt through the  $\overline{\text{INT}}$  output pin. Each of the alarms and events in the SR can be either masked or unmasked from the interrupt pin through the interrupt mask register (IMR). The interrupts caused by the RCL, RUA1, and LOTC bits in the SR act differently than the interrupts caused by the other status bits in the SR. The RCL, RUA1, and LOTC bits forces the  $\overline{\text{INT}}$  pin low whenever they change state (i.e., go active or inactive). The  $\overline{\text{INT}}$  pin is allowed to return high (if no other interrupts are present) when the user reads the alarm bit that caused the interrupt to occur, even if the alarm is still present. The other status bits in the SR can force the  $\overline{\text{INT}}$  pin low when they are set. The  $\overline{\text{INT}}$  pin is allowed to return high (if no other interrupts are present) when the user reads the event bit that caused the interrupt to occur.

The host can quickly determine which of the four LIU channels is generating an interrupt by reading one of the unused addresses in the 16h–1Fh range in any LIU channel. See the following LIU channel interrupt status description for additional information.

### LIU Channel Interrupt Status

(MSB)				(LSB)			
—	—	—	—	LIU4	LIU3	LIU2	LIU1

NAME	POSITION	FUNCTION
N/A	7	Not Assigned. Could be any value when read.
N/A	6	Not Assigned. Could be any value when read.
N/A	5	Not Assigned. Could be any value when read.
N/A	4	Not Assigned. Could be any value when read.
LIU4	3	LIU4 Status Register. A 1 in this bit position indicates that the status register (SR) in channel 4 is asserting an interrupt.
LIU3	2	LIU3 Status Register. A 1 in this bit position indicates that the status register (SR) in channel 3 is asserting an interrupt.
LIU2	1	LIU2 Status Register. A 1 in this bit position indicates that the status register (SR) in channel 2 is asserting an interrupt.
LIU1	0	LIU1 Status Register. A 1 in this bit position indicates that the status register (SR) in channel 1 is asserting an interrupt.

### SR (06H): Status Register

(MSB)				(LSB)			
LUP	LDN	LOTC	RUA1	RCL	TCLE	TOCD	PRBSD

NAME	POSITION	FUNCTION
LUP (Latched)	SR.7	Loop-Up Code Detected. This bit is set when the loop-up code defined in registers RUPCD1 and RUPCD2 is being received. See Section 6.1 for details.
LDN (Latched)	SR.6	Loop-Down Code Detected. This bit is set when the loop-down code defined in registers RDNCD1 and RDNCD2 is being received. See Section 6.1 for details.
LOTC (Real Time)	SR.5	Loss-of-Transmit Clock. This bit is set when the TCLK pin has not transitioned for 5 $\mu$ s ( $\pm 2\mu$ s), forcing the LOTC pin high.
RUA1 (Latched)	SR.4	Receive Unframed All Ones. This bit is set when an unframed all-ones code is received at RRING and RTIP (Table 5-A).
RCL (Latched)	SR.3	Receive Carrier Loss. This bit is set when an RCL condition exists at RRING and RTIP. See (Table 5-A) for details.
TCLE (Real Time)	SR.2	Transmit Current-Limit Exceeded. This bit is set when the 50mA (RMS) current limiter is activated whether or not the current limiter is enabled.
TOCD (Real Time)	SR.1	Transmit Open-Circuit Detect. This bit is set when the device detects that the TTIP and TRING outputs are open circuited.
PRBSD (Real Time)	SR.0	PRBS Detect. This bit is set when the receive side detects a $2^{15} - 1$ (E1) or a QRSS (T1) pseudorandom bit sequence (PRBS).

**Table 5-A. Received Alarm Criteria**

ALARM	E1/T1	SET CRITERIA	CLEAR CRITERIA
RUA1	E1	Fewer than two 0s in two frames (512 bits)	More than two 0s in two frames (512 bits)
RUA1	T1	Over a 3ms window, five or fewer 0s are received.	Over a 3ms window, six or more 0s are received.
RCL (Note 1)	E1	255 (or 2048) consecutive 0s received (G.775) (Note 2)	In 255-bit times, at least 32 1s are received.
RCL (Note 1)	T1	192 (or 1544) consecutive 0s are received (Note 2)	14 or more 1s out of 112 possible bit positions are received, starting with the first 1 received.

**Note 1:** RCL is also known as a loss of signal (LOS) or Red Alarm in T1.

**Note 2:** See CCR1.5 for details.

### IMR (07H): Interrupt Mask Register (MSB)

							(LSB)
LUP	LDN	LOTG	RUA1	RCL	TCLE	TOCD	PRBSD

NAME	POSITION	FUNCTION
LUP	IMR.7	Loop-Up Code Detected 0 = interrupt masked 1 = interrupt enabled
LDN	IMR.6	Loop-Down Code Detected 0 = interrupt masked 1 = interrupt enabled
LOTG	IMR.5	Loss-of-Transmit Clock 0 = interrupt masked 1 = interrupt enabled
RUA1	IMR.4	Receive Unframed All Ones 0 = interrupt masked 1 = interrupt enabled
RCL	IMR.3	Receive Carrier Loss 0 = interrupt masked 1 = interrupt enabled
TCLE	IMR.2	Transmit Current-Limiter Exceeded 0 = interrupt masked 1 = interrupt enabled
TOCD	IMR.1	Transmit Open-Circuit Detect 0 = interrupt masked 1 = interrupt enabled
PRBSD	IMR.0	PRBS Detection 0 = interrupt masked 1 = interrupt enabled

**RIR1 (08H): Receive Information Register 1****(MSB)****(LSB)**

ZD	16ZD	HBD	RCLC	RUA1C	JALT	—	—
----	------	-----	------	-------	------	---	---

NAME	POSITION	FUNCTION
ZD (Latched)	RIR1.7	Zero Detect. This bit is set when a string of at least four (ETS = 0) or eight (ETS = 1) consecutive 0s (regardless of the length of the string) have been received. This bit is cleared when read.
16ZD (latched)	RIR1.6	16 Zero Detect. This is set when at least 16 consecutive 0s (regardless of the length of the string) have been received. This bit is cleared when read.
HBD (Latched)	RIR1.5	HDB3/B8ZS Word Detect. This is set when an HDB3 (ETS = 0) or B8ZS (ETS = 1) codeword is detected independently of the receive HDB3/B8ZS mode (CCR4.6) being enabled. This bit is cleared when read. It is useful for automatically setting the line coding.
RCLC (Latched)	RIR1.4	RCL Clear. Set when the RCL alarm has met the clear criteria defined in <a href="#">Table 5-A</a> . This bit is cleared when read.
RUA1C (Latched)	RIR1.3	Receive Unframed All-Ones Clear. This bit is set when the unframed all-ones signal is no longer detected. This bit is cleared when read ( <a href="#">Table 5-A</a> ).
JALT (Latched)	RIR1.2	Jitter Attenuator Limit Trip. This bit is set when the jitter attenuator FIFO reaches within 4 bits of its useful limit. This bit is cleared when read and is useful for debugging jitter attenuation operation.
N/A	RIR1.1	Not Assigned. Could be any value when read.
N/A	RIR1.0	Not Assigned. Could be any value when read.

**RIR2 (09H): Receive Information Register 2****(MSB)****(LSB)**

RL3	RL2	RL1	RL0	—	—	ARLB	SEC
-----	-----	-----	-----	---	---	------	-----

NAME	POSITION	FUNCTION
RL3 (Real Time)	RIR2.7	Receive Level Bit 3 ( <a href="#">Table 5-B</a> )
RL2 (Real Time)	RIR2.6	Receive Level Bit 2 ( <a href="#">Table 5-B</a> )
RL1 (Real Time)	RIR2.5	Receive Level Bit 1 ( <a href="#">Table 5-B</a> )
RL0 (Real Time)	RIR2.4	Receive Level Bit 0 ( <a href="#">Table 5-B</a> )
N/A	RIR2.3	Not Assigned. Could be any value when read.
N/A	RIR2.2	Not Assigned. Could be any value when read.
ARLB (Real Time)	RIR2.1	Automatic Remote Loopback Detected. This bit is set to 1 when the automatic remote loopback circuitry has detected the presence of a loop-up code for 5 seconds. It remains set until the automatic RLB circuitry has detected the loop-down code for 5 seconds. See <a href="#">Section 11</a> for more details. This bit is forced low when the automatic RLB circuitry is disabled (CCR6.5 = 0).
SEC (Latched)	RIR2.0	One-Second Timer. This bit is set to 1 on one-second boundaries as timed by the device, based on the RCLK. It is cleared when read.

**Table 5-B. Receive Level Indication**

RL3	RL2	RL1	RL0	RECEIVE LEVEL (dB)
0	0	0	0	Greater than -2.5
0	0	0	1	-2.5 to -5.0
0	0	1	0	-5.0 to -7.5
0	0	1	1	-7.5 to -10.0
0	1	0	0	-10.0 to -12.5
0	1	0	1	-12.5 to -15.0
0	1	1	0	-15.0 to -17.5
0	1	1	1	-17.5 to -20.0
1	0	0	0	-20.0 to -22.5
1	0	0	1	-22.5 to -25.0
1	0	1	0	-25.0 to -27.5
1	0	1	1	-27.5 to -30.0
1	1	0	0	-30.0 to -32.5
1	1	0	1	-32.5 to -35.0
1	1	1	0	-35.0 to -37.5
1	1	1	1	-37.5 to -40.0

## 6. DIAGNOSTICS

### 6.1 In-Band Loop-Code Generation and Detection

The DS21448 can generate and detect a repeating bit pattern from 1 to 8 or 16 bits in length. To transmit a pattern, the user loads the pattern into the transmit code definition (TCD1 and TCD2) registers and selects the proper length of the pattern by setting the TC0 and TC1 bits in the in-band code control (IBCC) register. When generating a 1-, 2-, 4-, 8-, or 16-bit pattern, the transmit code registers (TCD1 and TCD2) must be filled with the proper code. Generation of a 1-, 3-, 5-, or 7-bit pattern only requires TCD1 to be filled. Once this is accomplished, the pattern is transmitted, as long as the TLCE control bit (CCR3.3) is enabled. For example, if the user wished to transmit the standard loop-up code for CSUs, which is a repeating pattern of ...10000100001..., then 80h would be loaded into TCD1, and the length would set using TC1 and TC0 in the IBCC register to 5 bits.

The DS21448 can detect two separate repeating patterns to allow for a loop-up code and a loop-down code to be detected. The user programs the codes in the receive-up code definition (RUPCD1 and RUPCD2) registers and the receive-down code definition (RDNCD1 and RDNCD2) registers; the length of each pattern is selected through the IBCC register. The DS21448 detects repeating pattern codes with bit-error rates as high as  $1 \times 10^{-2}$ . The code detector has a nominal integration period of 48ms, so after approximately 48ms of receiving either code, the proper status bit (LUP at SR.7 and LDN at SR.6) is set to 1. Normally codes are sent for a period of 5 seconds. It is recommended that the software poll the DS21448 every 100ms to 1000ms until 5 seconds has elapsed to ensure the code is continuously present.

#### IBCC (0AH): In-Band Code Control Register

(MSB)						(LSB)	
TC1	TC0	RUP2	RUP1	RUP0	RDN2	RDN1	RDN0

NAME	POSITION	FUNCTION
TC1	IBCC.7	Transmit Code Length Definition Bit 1 ( <a href="#">Table 6-A</a> )
TC0	IBCC.6	Transmit Code Length Definition Bit 0. ( <a href="#">Table 6-A</a> )
RUP2	IBCC.5	Receive Up Code Length Definition Bit 2 ( <a href="#">Table 6-B</a> )
RUP1	IBCC.4	Receive-Up Code Length Definition Bit 1 ( <a href="#">Table 6-B</a> )
RUP0	IBCC.3	Receive-Up Code Length Definition Bit 0 ( <a href="#">Table 6-B</a> )
RDN2	IBCC.2	Receive-Down Code Length Definition Bit 2 ( <a href="#">Table 6-B</a> )
RDN1	IBCC.1	Receive-Down Code Length Definition Bit 1 ( <a href="#">Table 6-B</a> )
RDN0	IBCC.0	Receive-Down Code Length Definition Bit 0 ( <a href="#">Table 6-B</a> )

**Table 6-A. Transmit Code Length**

TC1	TC0	LENGTH SELECTED (BITS)
0	0	5
0	1	6/3
1	0	7
1	1	16/8/4/2/1

**Table 6-B. Receive Code Length**

RUP2/RDN2	RUP1/RDN1	RUP0/RDN0	LENGTH SELECTED (BITS)
0	0	0	1
0	0	1	2
0	1	0	3
0	1	1	4
1	0	0	5
1	0	1	6
1	1	0	7
1	1	1	16/8

**TCD1 (0BH): Transmit Code Definition Register 1**

(MSB)

(LSB)

C7	C6	C5	C4	C3	C2	C1	C0
----	----	----	----	----	----	----	----

NAME	POSITION	FUNCTION
C7	TCD1.7	Transmit Code Definition Bit 7. First bit of the repeating pattern.
C6	TCD1.6	Transmit Code Definition Bit 6
C5	TCD1.5	Transmit Code Definition Bit 5
C4	TCD1.4	Transmit Code Definition Bit 4
C3	TCD1.3	Transmit Code Definition Bit 3
C2	TCD1.2	Transmit Code Definition Bit 2. A don't care if a 5-bit length is selected.
C1	TCD1.1	Transmit Code Definition Bit 1. A don't care if a 5-bit or 6-bit length is selected.
C0	TCD1.0	Transmit Code Definition Bit 0. A don't care if a 5-, 6-, or 7-bit length is selected.

**TCD2 (0CH): Transmit Code Definition Register 2**

(MSB)

(LSB)

C15	C14	C13	C12	C11	C10	C9	C8
-----	-----	-----	-----	-----	-----	----	----

NAME	POSITION	FUNCTION
C15	TCD2.7	Transmit Code Definition Bit 15
C14	TCD2.6	Transmit Code Definition Bit 14
C13	TCD2.5	Transmit Code Definition Bit 13
C12	TCD2.4	Transmit Code Definition Bit 12
C11	TCD2.3	Transmit Code Definition Bit 11
C10	TCD2.2	Transmit Code Definition Bit 10
C9	TCD2.1	Transmit Code Definition Bit 9
C8	TCD2.0	Transmit Code Definition Bit 8

**RUPCD1 (0DH): Receive-Up Code Definition Register 1****(MSB)****(LSB)**

C7	C6	C5	C4	C3	C2	C1	C0
----	----	----	----	----	----	----	----

NAME	POSITION	FUNCTION
C7	RUPCD1.7	Receive-Up Code Definition Bit 7. First bit of the repeating pattern.
C6	RUPCD1.6	Receive-Up Code Definition Bit 6. A don't care if a 1-bit length is selected.
C5	RUPCD1.5	Receive-Up Code Definition Bit 5. A don't care if a 1-bit or 2-bit length is selected.
C4	RUPCD1.4	Receive-Up Code Definition Bit 4. A don't care if a 1-bit to 3-bit length is selected.
C3	RUPCD1.3	Receive-Up Code Definition Bit 3. A don't care if a 1-bit to 4-bit length is selected.
C2	RUPCD1.2	Receive-Up Code Definition Bit 2. A don't care if a 1-bit to 5-bit length is selected.
C1	RUPCD1.1	Receive-Up Code Definition Bit 1. A don't care if a 1-bit to 6-bit length is selected.
C0	RUPCD1.0	Receive-Up Code Definition Bit 0. A don't care if a 1-bit to 7-bit length is selected.

**RUPCD2 (0EH): Receive-Up Code Definition Register 2****(MSB)****(LSB)**

C15	C14	C13	C12	C11	C10	C9	C8
-----	-----	-----	-----	-----	-----	----	----

NAME	POSITION	FUNCTION
C15	RUPCD2.7	Receive-Up Code Definition Bit 15
C14	RUPCD2.6	Receive-Up Code Definition Bit 14
C13	RUPCD2.5	Receive-Up Code Definition Bit 13
C12	RUPCD2.4	Receive-Up Code Definition Bit 12
C11	RUPCD2.3	Receive-Up Code Definition Bit 11
C10	RUPCD2.2	Receive-Up Code Definition Bit 10
C9	RUPCD2.1	Receive-Up Code Definition Bit 9
C8	RUPCD2.0	Receive-Up Code Definition Bit 8

**RDNCD1 (0FH): Receive-Down Code Definition Register 1****(MSB)****(LSB)**

C7	C6	C5	C4	C3	C2	C1	C0
----	----	----	----	----	----	----	----

NAME	POSITION	FUNCTION
C7	RDNCD1.7	Receive-Down Code Definition Bit 7. First bit of the repeating pattern.
C6	RDNCD1.6	Receive-Down Code Definition Bit 6. A don't care if a 1-bit length is selected.
C5	RDNCD1.5	Receive-Down Code Definition Bit 5. A don't care if a 1-bit or 2-bit length is selected.
C4	RDNCD1.4	Receive-Down Code Definition Bit 4. A don't care if a 1-bit to 3-bit length is selected.
C3	RDNCD1.3	Receive-Down Code Definition Bit 3. A don't care if a 1-bit to 4-bit length is selected.
C2	RDNCD1.2	Receive-Down Code Definition Bit 2. A don't care if a 1-bit to 5-bit length is selected.
C1	RDNCD1.1	Receive-Down Code Definition Bit 1. A don't care if a 1-bit to 6-bit length is selected.
C0	RDNCD1.0	Receive-Down Code Definition Bit 0. A don't care if a 1-bit to 7-bit length is selected.

**RDNCD2 (10H): Receive-Down Code Definition Register 2****(MSB)****(LSB)**

C15	C14	C13	C12	C11	C10	C9	C8
-----	-----	-----	-----	-----	-----	----	----

NAME	POSITION	FUNCTION
C15	RDNCD2.7	Receive-Down Code Definition Bit 15
C14	RDNCD2.6	Receive-Down Code Definition Bit 14
C13	RDNCD2.5	Receive-Down Code Definition Bit 13
C12	RDNCD2.4	Receive-Down Code Definition Bit 12
C11	RDNCD2.3	Receive-Down Code Definition Bit 11
C10	RDNCD2.2	Receive-Down Code Definition Bit 10
C9	RDNCD2.1	Receive-Down Code Definition Bit 9
C8	RDNCD2.0	Receive-Down Code Definition Bit 8

## 6.2 Loopbacks

### 6.2.1 Remote Loopback (RLB)

When RLB (CCR6.6) is enabled, the DS21448 is placed into remote loopback. In this loopback, data from the clock/data recovery state machine is looped back to the transmit path, passing through the jitter attenuator if it is enabled. The data at the RPOS and RNEG pins is valid, while data presented at TPOS and TNEG is ignored. See [Figure 1-1](#) for more details.

If the automatic RLB enable (CCR6.5) is set to 1, the DS21448 automatically goes into remote loopback when it detects the loop-up code programmed in the receive-up code definition registers (RUPCD1 and RUPCD2) for a minimum of 5 seconds. When the DS21448 detects the loop-down code programmed in the receive loop-down code definition registers (RDNCD1 and RDNCD2) for a minimum of 5 seconds, the DS21448 comes out of remote loopback. Setting ARLBE to 0 can also disable the ARLB.

### 6.2.2 Local Loopback (LLB)

When LLB (CCR6.7) is set to 1, the DS21448 is placed into local loopback. In this loopback, data on the transmit side is transmitted as normal. TCLK and TPOS/TNEG pass through the jitter attenuator (if enabled) and are output at RCLK and RPOS/RNEG. Incoming data from the line at RTIP and RRING is ignored. If transmit unframed all ones (CCR3.7) is set to 1 while in LLB, TTIP and TRING transmit all ones while TCLK and TPOS/TNEG are looped back to RCLK and RPOS/RNEG. See [Figure 1-1](#) for more details.

### 6.2.3 Analog Loopback (LLB)

Setting ALB (CCR6.4) to 1 puts the DS21448 in analog loopback. Signals at TTIP and TRING are internally connected to RTIP and RRING. The incoming signals at RTIP and RRING are ignored. The signals at TTIP and TRING are transmitted as normal. See [Figure 1-1](#) for more details.

### 6.2.4 Dual Loopback (DLB)

Setting CCR6.7 and CCR6.6 (LLB and RLB, respectively) to 1 puts the DS21448 into dual loopback operation. The TCLK and TPOS/TNEG signals are looped back through the jitter attenuator (if enabled) and output at RCLK and RPOS/RNEG. Clock and data recovered from RTIP and RRING are looped back to the transmit side and output at TTIP and TRING. This mode of operation is not available when implementing hardware operation. See [Figure 1-1](#) more details.

## 6.3 PRBS Generation and Detection

Setting TPRBSE (CCR3.4) = 1 enables the DS21448 to transmit a  $2^{15} - 1$  (E1) or a QRSS (T1) PRBS, depending on the ETS bit setting in CCR1.7. The DS21448's receive side always searches for these PRBS patterns independently of CCR3.4. The PRBS bit-error output (PBEO) remains high until the receiver has synchronized to one of the two patterns (64 bits received without an error), at which time PBEO goes low, and the PRBSD bit in the SR is set. Once synchronized, any bit errors received cause a positive-going pulse at PBEO, synchronous with RCLK. This output can be used with external circuitry track bit-error rates during the PRBS testing. Setting CCR6.2 (ECRS2) = 1 allows the PRBS errors to be accumulated in the 16-bit counter in registers ECR1 and ECR2. The PRBS synchronizer remains in sync until it experiences six bit errors or more within a 64-bit span. Both PRBS patterns comply with the ITU-T O.151 specifications.

## 6.4 Error Counter

Error count register 1 (ECR1) is the most significant word and ECR2 is the least significant word of a user-selectable 16-bit counter that records incoming errors, including BPVs, code violations (CVs), excessive zero violations (EXZs), and/or PRBS errors. See [Table 6-C](#), [Table 6-D](#), and [Figure 1-2](#) for details.

**Table 6-C. Definition of Received Errors**

ERROR	E1 OR T1	DEFINITION OF RECEIVED ERRORS
BPV	E1/T1	Two consecutive marks with the same polarity. Ignores BPVs because of HDB3 and B8ZS zero suppression when CCR2.3 = 0. Typically used with AMI coding (CCR2.3 = 1). ITU-T O.161.
CV	E1	When HDB3 is enabled (CCR2.3 = 0) and the receiver detects two consecutive BPVs with the same polarity. ITU-T O.161.
EXZ	E1	When four or more consecutive zeros are detected.
EXZ	T1	When receiving AMI-coded signals (CCR2.3 = 1), detection of 16 or more 0s or a BPV. ANSI T1.403 1999.
		When receiving B8ZS-coded signals (CCR2.3 = 0), detection of eight or more 0s or a BPV. ANSI T1.403 1999.
PRBS	E1/T1	A bit error in a received PRBS pattern. See Section 6.3 for details. ITU-T O.151.

**Table 6-D. Function of ECRS Bits and RNEG Pin**

E1 or T1 (CCR1.7)	ECRS2 (CCR6.2)	ECRS1 (CCR6.1)	ECRS0 (CCR6.0)	RHBE (CCR2.3)	FUNCTION OF ECR COUNTERS/RNEG (Note 1)
0	0	0	0	X	CVs
0	0	0	1	X	BPVs (HDB3 codewords not counted)
0	0	1	0	X	CVs + EXZs
0	0	1	1	X	BPVs + EXZs
1	0	X	0	0	BPVs (B8ZS codewords not counted)
1	0	X	1	0	BPVs + 8 EXZs
1	0	X	0	1	BPVs
1	0	X	1	1	BPVs + 16 EXZs
X	1	X	X	X	PRBS Errors (Note 2)

**Note 1:** RNEG outputs error data only when in NRZ mode (CCR1.6 = 1).

**Note 2:** PRBS errors are always output at PBEO, independent of ECR control bits and NRZ mode, and are not present at RNEG.

## 6.5 Error Counter Update

A 0-to-1 transition of the ECUE (CCR1.4) control bit updates the ECR registers with the current values and resets the counters. ECUE must be set back to 0 and another 0-to-1 transition must occur for subsequent reads/resets of the ECR registers. Note that the DS21448 can report errors at RNEG when in NRZ mode (CCR1.6 = 1) by outputting a pulse for each error occurrence. The counter saturates at 65,535 and does not roll over.

### ECR1 (11H): Upper Error Count Register 1/ECR2 (12H): Lower Error Count Register 2

(MSB)				(LSB)				
E15	E14	E13	E12	E11	E10	E9	E8	ECR1
E7	E6	E5	E4	E3	E2	E1	E0	ECR2

NAME	POSITION	FUNCTION
E15	ECR1.7	MSB of the 16-bit error count.
E0	ECR2.0	LSB of the 16-bit error count.

## 6.6 Error Insertion

When IBPV (CCR3.1) is transitioned from 0 to 1, the device waits for the next occurrence of three consecutive 1s to insert a BPV. IBPV must be cleared and set again for another BPV error insertion. See [Figure 1-3](#) for details on the insertion of the BPV into the data stream.

When IBE (CCR3.0) is transitioned from 0 to 1, the device inserts a logic error. IBE must be cleared and set again for another logic error insertion. See [Figure 1-2](#) and [Figure 1-3](#) for details about the logic error insertion into the data stream.

## 7. ANALOG INTERFACE

### 7.1 Receiver

The DS21448 contains a digital clock recovery system. The DS21448 couples to the receive E1 or T1 twisted pair (or coaxial cable in 75 $\Omega$  E1 applications) through a 1:1 transformer. See [Table 7-C](#) for transformer details. [Figure 7-1](#), [Figure 7-2](#), [Figure 7-3](#), and [Table 4-L](#) show the receive termination requirements. The DS21448 has the option of using internal termination resistors.

The DS21448 is designed to be fully software selectable for E1 and T1 without the need to change any external resistors for the receive side. The receive side allows user configuration for 75 $\Omega$ , 100 $\Omega$ , or 120 $\Omega$  receive termination by setting the RT1 (CCR5.1) and RT0 (CCR5.0) bits. When using the internal termination feature, the  $R_r$  resistors should be 60 $\Omega$  each. See [Figure 7-1](#) for details. If external termination is required, RT1 and RT0 should be set to 0, and both  $R_r$  resistors ([Figure 7-1](#)) should be 37.5 $\Omega$ , 50 $\Omega$ , or 60 $\Omega$  each, depending on the line impedance.

The resultant E1 or T1 clock derived from the 2.048/1.544 PLL (JACLK in [Figure 1-1](#)) is internally multiplied by 16 through another internal PLL and fed to the clock recovery system. The clock recovery system uses the clock from the PLL circuit to form a 16-times oversampler used to recover the clock and data. This oversampling technique offers outstanding performance to meet jitter tolerance specifications, as shown in [Figure 7-7](#).

Normally, the clock that is output at the RCLK pin is the recovered clock from the E1 AMI/HDB3 or T1 AMI/B8ZS waveform presented at the RTIP and RRING inputs. When no signal is present at RTIP and RRING, an RCL condition occurs, and the RCLK is derived from the JACLK source. See [Figure 1-1](#) for more details. If the jitter attenuator is placed in the receive path (as is the case in most applications), the jitter attenuator restores the RCLK to an approximate 50% duty cycle. If the jitter attenuator is either placed in the transmit path or is disabled, the RCLK output can exhibit slightly shorter high cycles of the clock. This is because of the highly oversampled digital clock recovery circuitry. See the receive-side AC timing characteristics in Section [10](#) for more details.

The receive-side circuitry also contains a clock synthesizer that outputs a user-configurable clock (up to 16.384MHz) synthesized from RCLK at BPCLK (pin 31). See [Table 4-J](#) for details about output clock frequencies at BPCLK. In hardware mode, BPCLK defaults to a 16.384MHz output.

The DS21448 has a bypass mode for the receive-side clock and data. This allows the BPCLK to be derived from RCLK after the jitter attenuator, while the clock and data presented at RCLK, RPOS, and RNEG go unaltered. This is intended for applications where the receive-side jitter attenuation is done after the LIU. Setting RJOB (CCR6.3) to logic 1 enables the bypass. Ensure the jitter attenuator is in the receive path (CCR4.3 = 0). See [Figure 1-1](#) for more details.

The DS21448 reports the signal strength at RTIP and RRING in 2.5dB increments through RL3–RL0 located in the receive information register 2. This feature is helpful when troubleshooting line performance problems ([Table 5-B](#)).

E1 and T1 monitor applications require various flat-gain settings for the receive-side circuitry. The DS21448 can be programmed to support these applications through the monitor mode control bits MM1 and MM0. When the monitor modes are enabled, the receiver tolerates normal line loss up to -6dB ([Table 4-K](#)).

### 7.2 Transmitter

The DS21448 uses a set of laser-trimmed delay lines with a precision digital-to-analog converter (DAC) to create the waveforms that are transmitted onto the E1 or T1 line. The waveforms meet the latest ETSI, ITU, ANSI, and AT&T specifications. The user selects which waveform to generate by setting the ETS bit (CCR1.7) for E1 or T1 operation, then programming the L2/L1/L0 bits in common control register 4 for the appropriate application. See [Table 7-A](#) and [Table 7-B](#) for the proper L2/L1/L0 settings.

A 2.048MHz or 1.544MHz TTL clock is required at TCLK for transmitting data at TPOS and TNEG. ITU specification G.703 requires  $\pm 50$ ppm accuracy for T1 and E1. TR62411 and ANSI specs require  $\pm 32$ ppm accuracy for T1 interfaces. The clock can be sourced internally by RCLK or JACLK. See CCR1.2, CCR1.1, CCR1.0, and [Figure 1-3](#) for details. Because of the transmitter's design, very little jitter (less than 0.005UI<sub>P-P</sub> broadband from

10Hz to 100kHz) is added to the jitter present on TCLK. Also, the waveforms created are independent of the duty cycle of TCLK. The transmitter couples to the E1 or T1 transmit-twisted pair (or coaxial cable in some E1 applications) through a 1:2 step-up transformer. For the device to create the proper waveforms, the transformer used must meet the specifications listed in [Table 7-C](#).

The DS21448 has an automatic short-circuit limiter that limits the source current to 50mA (RMS) into a 1 $\Omega$  load. This feature can be disabled by setting the SCLD bit (CCR2.5) = 1. When the current limiter is activated, TCLE (SR.2) is set even if the short-circuit limiter is disabled. The TPD bit (CCR4.0) powers down the transmit-line driver and tri-states the TTIP and TRING pins. The DS21448 can also detect when the TTIP or TRING outputs are open circuited. When an open circuit is detected, TOCD (SR.1) is set.

### 7.3 Jitter Attenuator

The DS21448 contains an on-board jitter attenuator that can be set to a depth of either 32 or 128 bits through the JABDS bit (CCR4.2). The 128-bit mode is used in applications where large excursions of wander are expected. The 32-bit mode is used in delay-sensitive applications. [Figure 7-8](#) shows the attenuation characteristics. The jitter attenuator can be placed in either the receive path or the transmit path by appropriately setting or clearing the JAS bit (CCR4.3). Also, setting the DJA bit (CCR4.1) can disable the jitter attenuator (in effect, remove it). For the jitter attenuator to operate properly, a 2.048MHz or 1.544MHz clock must be applied at MCLK. ITU specification G.703 requires  $\pm 50$ ppm accuracy for T1 and E1. TR62411 and ANSI specs require  $\pm 32$ ppm accuracy for T1 interfaces. An on-board PLL for the jitter attenuator converts the 2.048MHz clock to a 1.544MHz rate for T1 applications. Setting JAMUX (CCR1.3) to logic 0 bypasses this PLL. On-board circuitry adjusts either the recovered clock from the clock/data recovery block or the clock applied at the TCLK pin to create a smooth jitter-free clock, which is used to clock data out of the jitter attenuator FIFO. It is acceptable to provide a gapped/bursty clock at the TCLK pin if the jitter attenuator is placed on the transmit side. If the incoming jitter exceeds either 120UI<sub>P,P</sub> (buffer depth is 128 bits) or 28UI<sub>P,P</sub> (buffer depth is 32 bits), the DS21448 divides the internal nominal 32.768MHz (E1) or 24.704MHz (T1) clock by either 15 or 17 instead of the normal 16 to keep the buffer from overflowing. When the device divides by either 15 or 17, it also sets the JALT bit in the receive information register 1 (RIR1).

### 7.4 G.703 Synchronization Signal

The DS21448 can receive a 2.048MHz square-wave synchronization clock, as specified in Section 10 of ITU G.703. To use the DS21448 in this mode, set the receive-synchronization-clock enable (CCR5.3) = 1. The DS21448 can also transmit the 2.048MHz square-wave synchronization clock, as specified in Section 10 of G.703. To transmit the 2.048MHz clock, set the transmit-synchronization-clock enable (CCR5.2) = 1.

**Table 7-A. Line Build-Out Select for E1 in Register CCR4 (ETS = 0)**

L2	L1	L0	APPLICATION	N	RETURN LOSS	R <sub>t</sub> ( $\Omega$ )
0	0	0	75 $\Omega$ normal	1:2	N.M.	0
0	0	1	120 $\Omega$ normal	1:2	N.M.	0
1	0	0	75 $\Omega$ with high return loss	1:2	21dB	6.2
1	0	1	120 $\Omega$ with high return loss	1:2	21dB	11.6

**Table 7-B. Line Build-Out Select for T1 in Register CCR4 (ETS = 1)**

L2	L1	L0	APPLICATION	N	RETURN LOSS	R <sub>t</sub> ( $\Omega$ )
0	0	0	DSX-1 (0 to 133ft)/0dB CSU	1:2	N.M.	0
0	0	1	DSX-1 (133 to 266f)	1:2	N.M.	0
0	1	0	DSX-1 (266 to 399ft)	1:2	N.M.	0
0	1	1	DSX-1 (399 to 533ft)	1:2	N.M.	0
1	0	0	DSX-1 (533 to 655ft)	1:2	N.M.	0
1	0	1	-7.5dB CSU	1:2	N.M.	0
1	1	0	-15dB CSU	1:2	N.M.	0
1	1	1	-22.5dB CSU	1:2	N.M.	0

**Note:** See [Figure 7-1](#), [Figure 7-2](#), and [Figure 7-3](#).  
N.M. = Not meaningful.

**Table 7-C. Line Build-Out Select for E1 in Register CCR4 (ETS = 0) Using Alternate Transformer Configuration**

L2	L1	L0	APPLICATION	N	RETURN LOSS	R <sub>t</sub> (Ω)
0	0	0	75Ω normal	0.8:1:1CT	N.M.	0
0	0	1	120Ω normal	0.8:1:1CT	N.M.	0
1	0	0	75Ω with high return loss	0.8:1:1CT	21dB	11.6
1	0	1	120Ω with high return loss	0.8:1:1CT	21dB	11.6

Note: See [Figure 7-4](#).

**Table 7-D. Transformer Specifications (3.3V Operation)**

SPECIFICATION	RECOMMENDED VALUE
Turns Ratio	1:1 (receive) and 1:2 (transmit) ±2%
Primary Inductance	600μH (min)
Leakage Inductance	1.0μH (max)
Interwinding Capacitance	40pF (max)
<b>TRANSMIT TRANSFORMER DC RESISTANCE</b>	
Primary (Device Side)	1.0Ω (max)
Secondary	1.5Ω (max)
<b>RECEIVE TRANSFORMER DC RESISTANCE</b>	
Primary (Device Side)	1.2Ω (max)
Secondary	1.2Ω (max)

Figure 7-1. Basic Interface

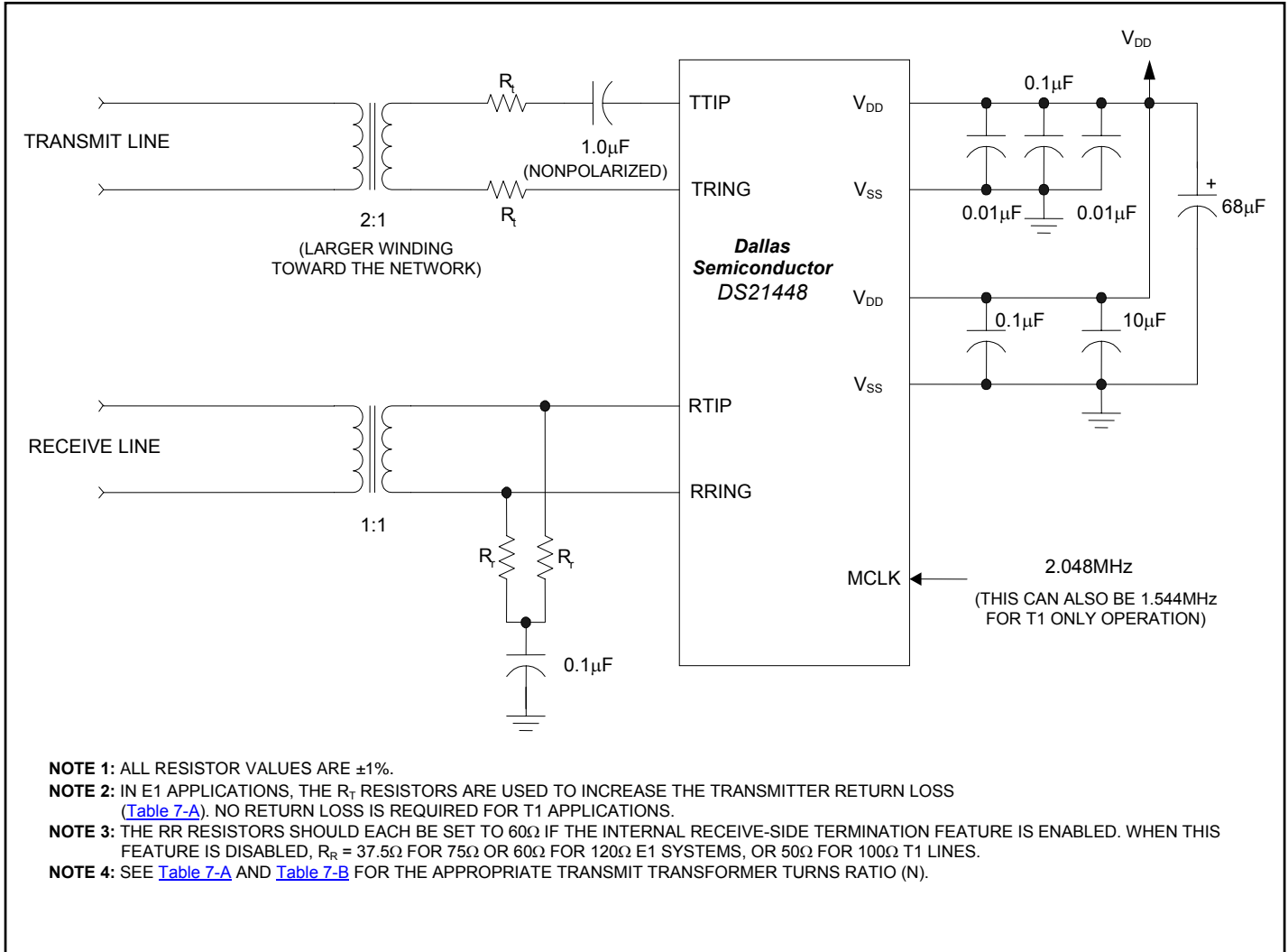

**Figure 7-2. Protected Interface Using Internal Receive Termination**

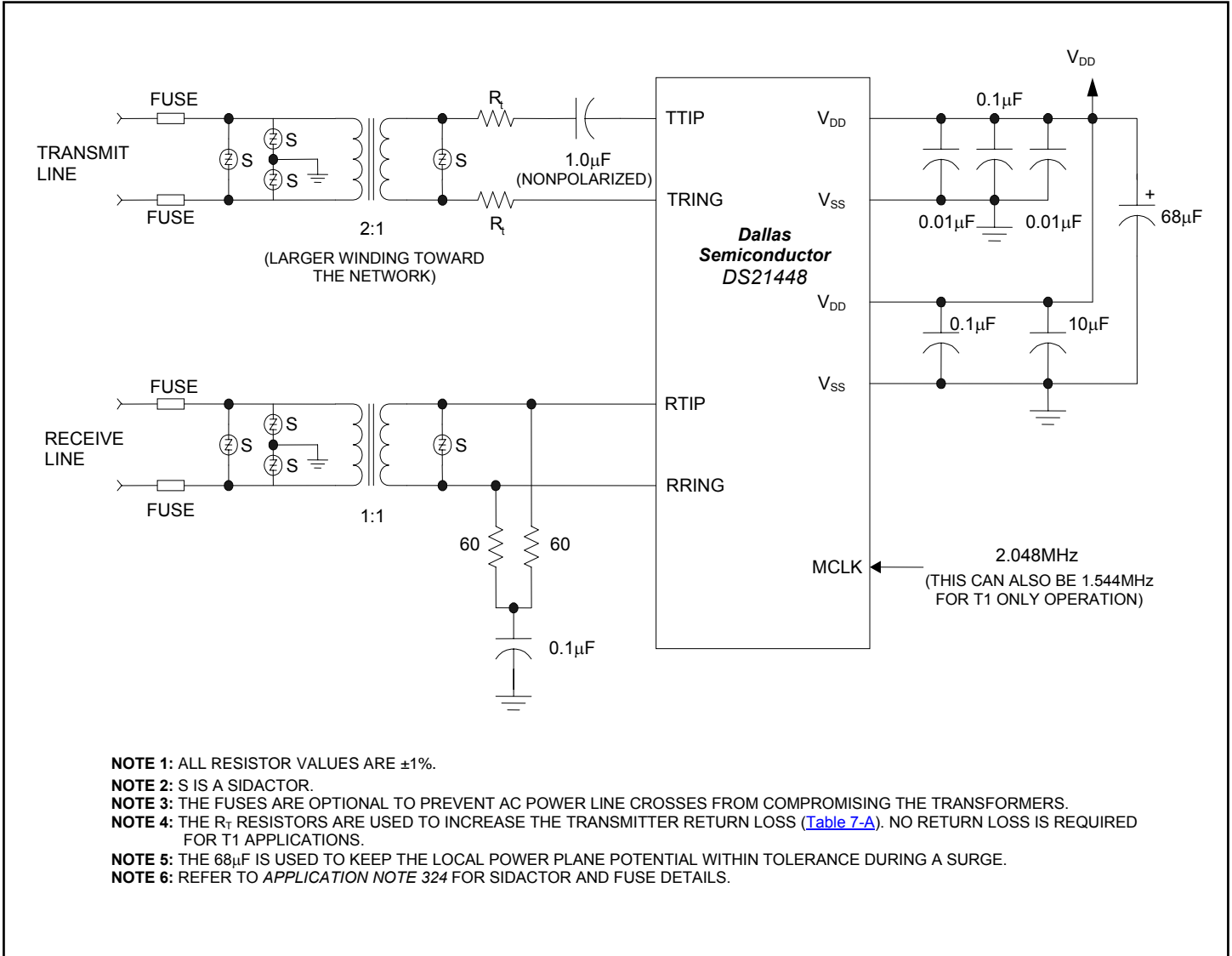

Figure 7-3. Protected Interface Using External Receive Termination

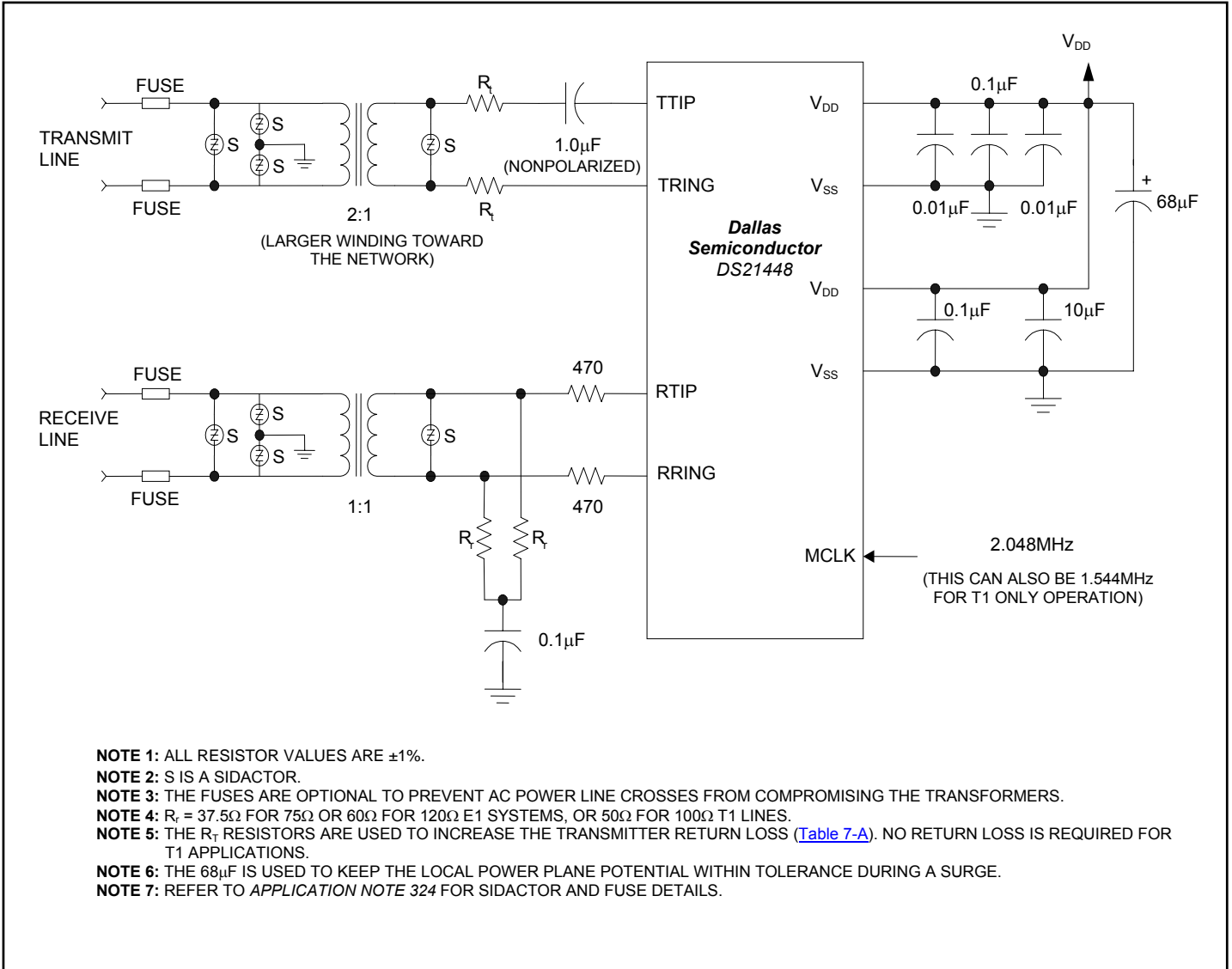

Figure 7-4. Dual Connector-Protected Interface Using Receive Termination

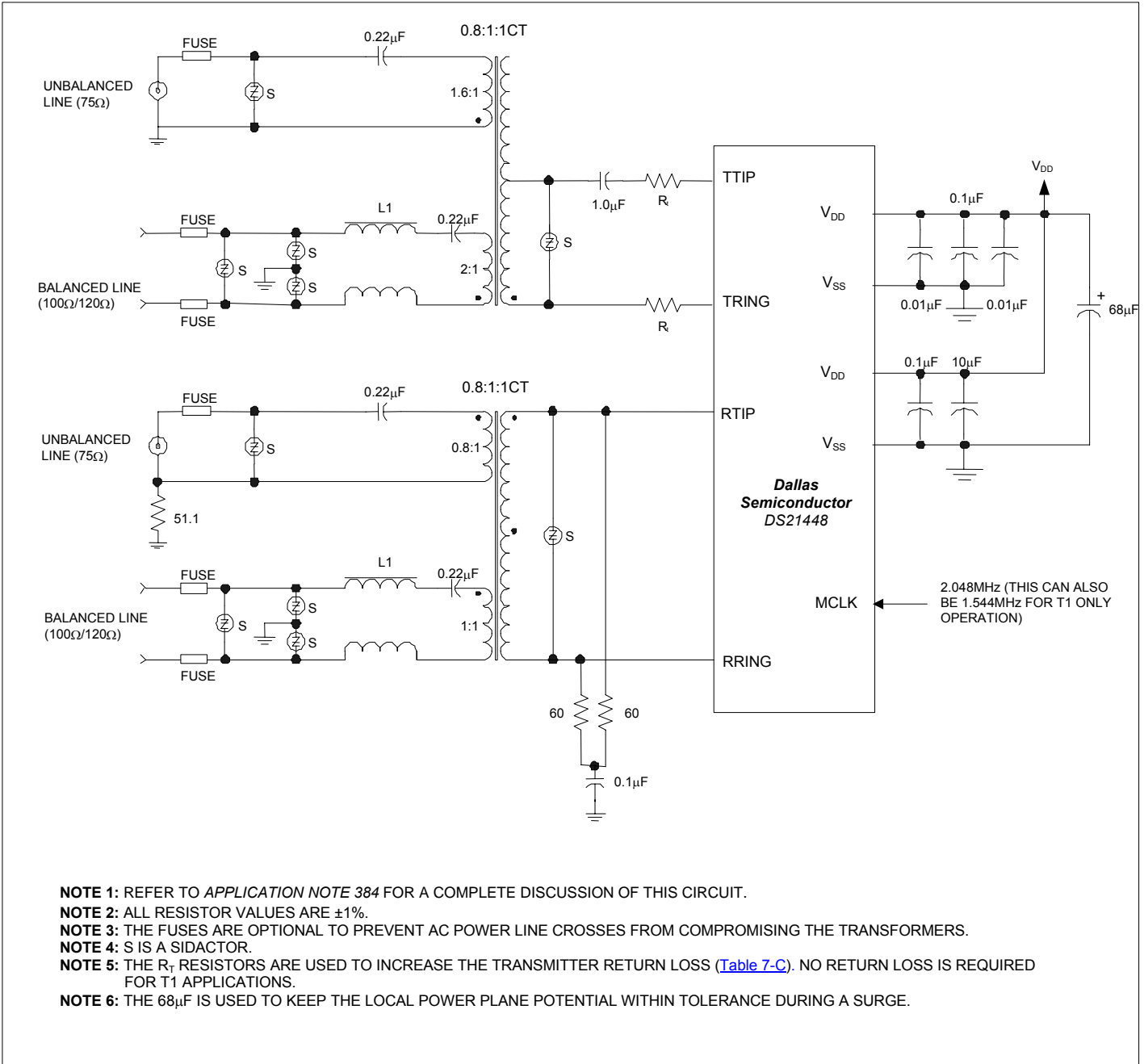

Figure 7-5. E1 Transmit Pulse Template

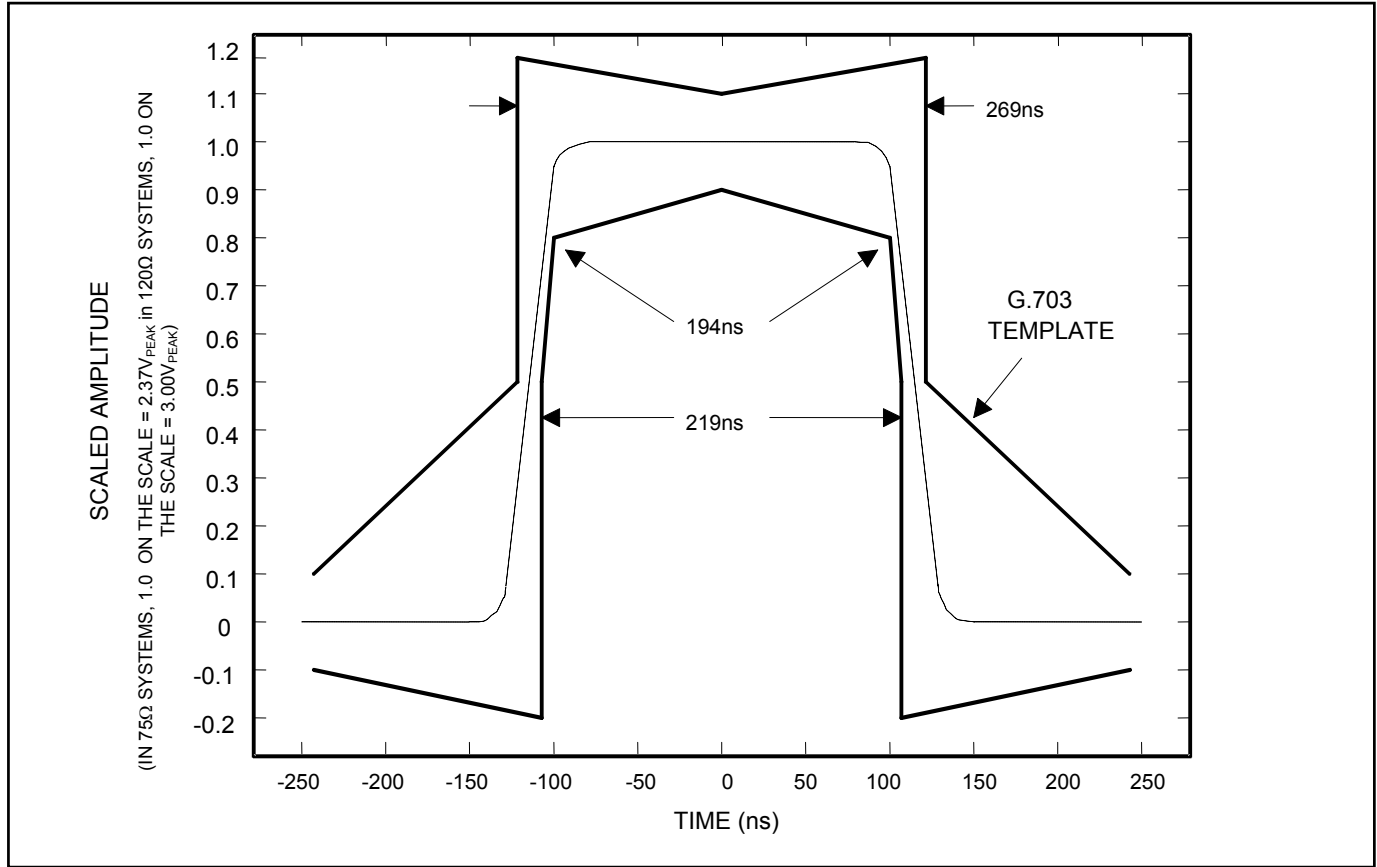

Figure 7-6. T1 Transmit Pulse Template

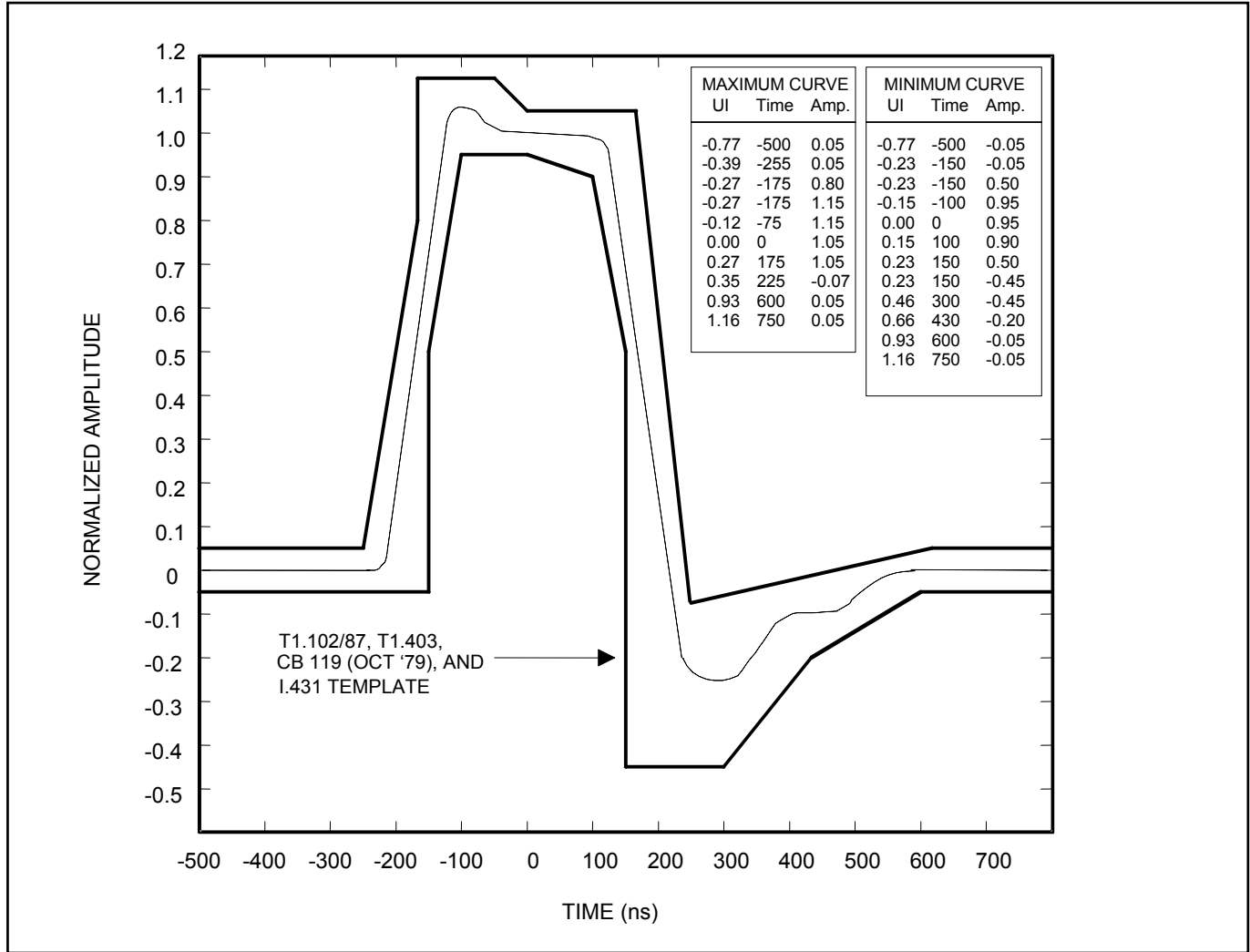

Figure 7-7. Jitter Tolerance

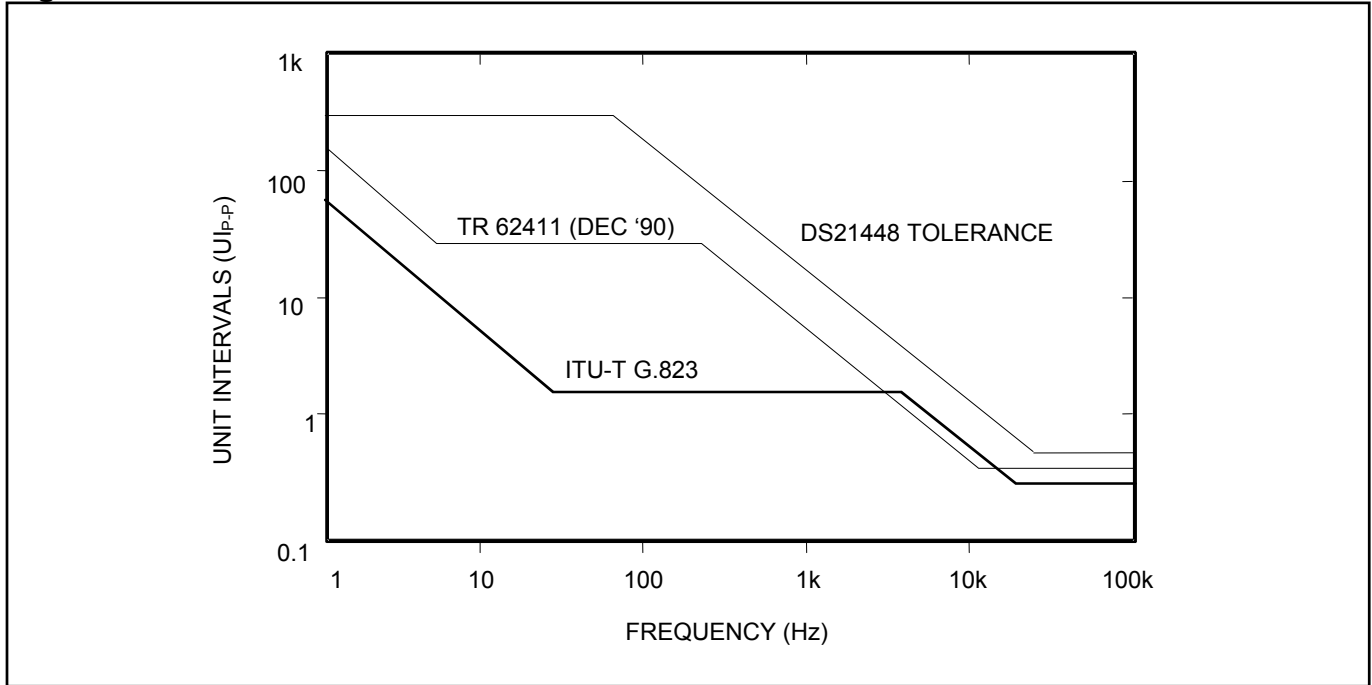
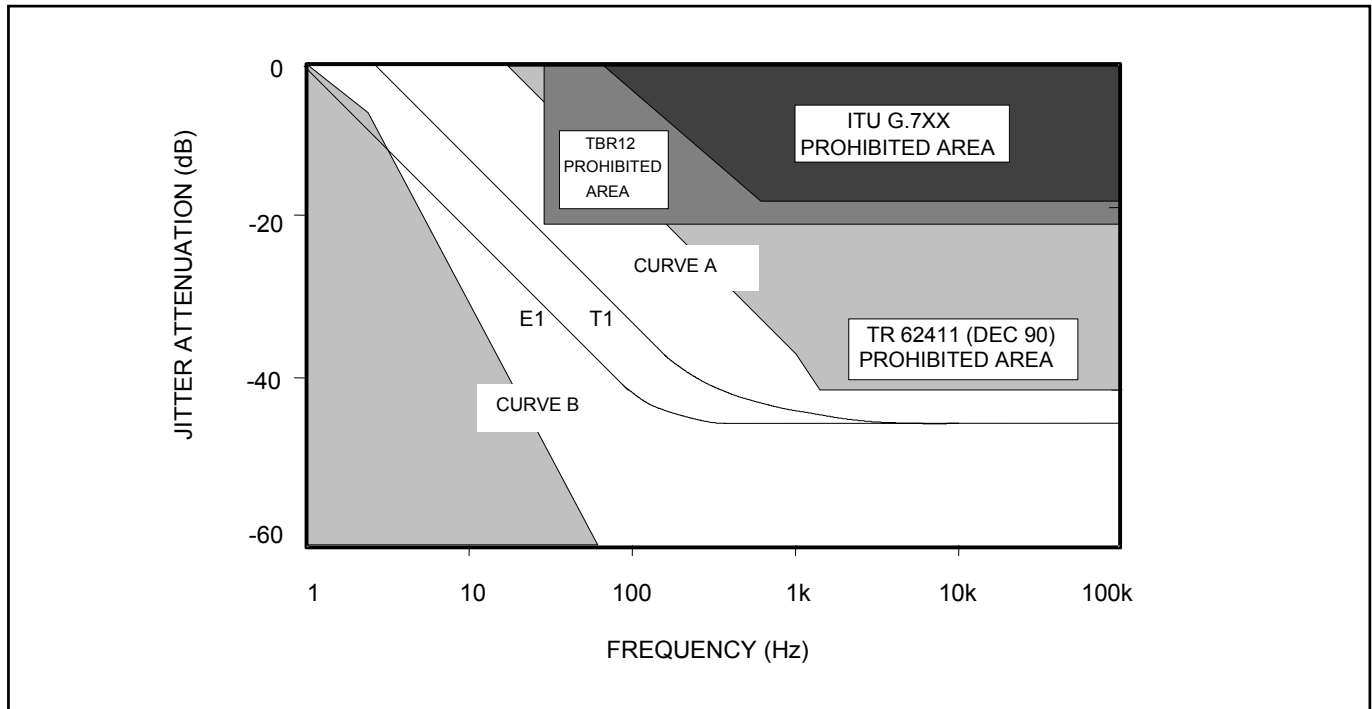

Figure 7-8. Jitter Attenuation



## 8. JTAG BOUNDARY SCAN ARCHITECTURE AND TEST ACCESS PORT

The DS21448 IEEE 1149.1 design supports the standard instruction codes SAMPLE/PRELOAD, BYPASS, and EXTEST. Optional public instructions included are HIGHZ, CLAMP, and IDCODE (Table 8-A). The DS21448 contains the following items, which meet the requirements set by the IEEE 1149.1 Standard Test Access Port (TAP) and Boundary Scan Architecture:

Test Access Port  
TAP Controller  
Instruction Register

Bypass Register  
Boundary Scan Register  
Device Identification Register

The TAP has the necessary interface pins JTRST, JTCLK, JTMS, JTDI, and JTDO. See the pin descriptions in Section 1 for details. Details on Boundary Scan Architecture and the Test Access Port can be found in IEEE 1149.1-1990, IEEE 1149.1a-1993, and IEEE 1149.1b-1994.

**Figure 8-1. JTAG Block Diagram**

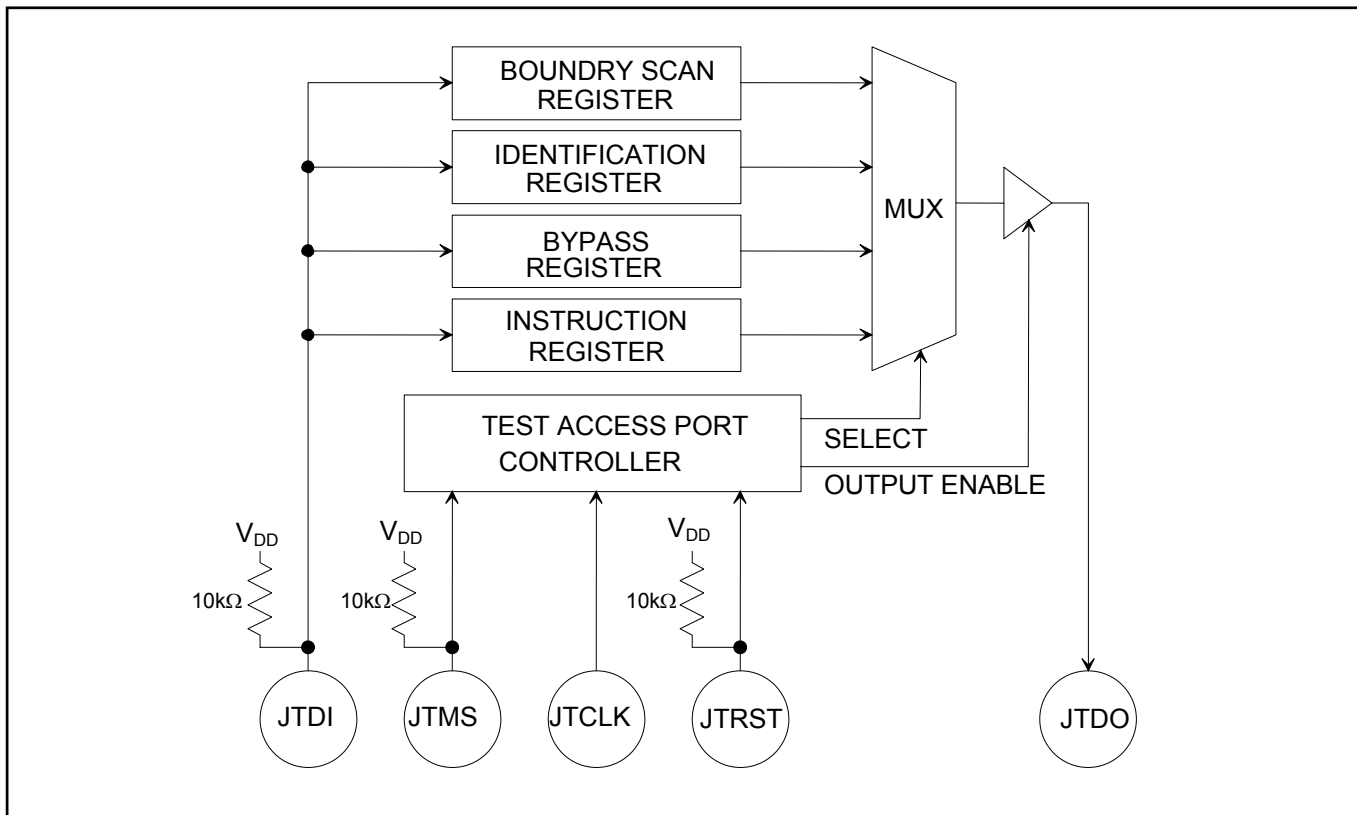

### 8.1 JTAG TAP Controller State Machine

This section covers the operation of the TAP controller state machine. See Figure 8-2 for details on each of the states described below. The TAP controller is a finite state machine that responds to the logic level at JTMS on the rising edge of JTCLK (Table 8-B).

**Test-Logic-Reset.** Upon power-up, the TAP controller is in test-logic-reset state. The instruction register contains the IDCODE instruction. All system logic of the device operates normally.

**Run-Test-Idle.** The run-test-idle is used between scan operations or during specific tests. The instruction register and test registers remain idle.

**Select-DR-Scan.** All test registers retain their previous state. With JTMS LOW, a rising edge of JTCLK moves the controller into the capture-DR state and initiates a scan sequence. JTMS HIGH during a rising edge on JTCLK moves the controller to the select-IR-scan state.

Figure 8-2. TAP Controller State Diagram

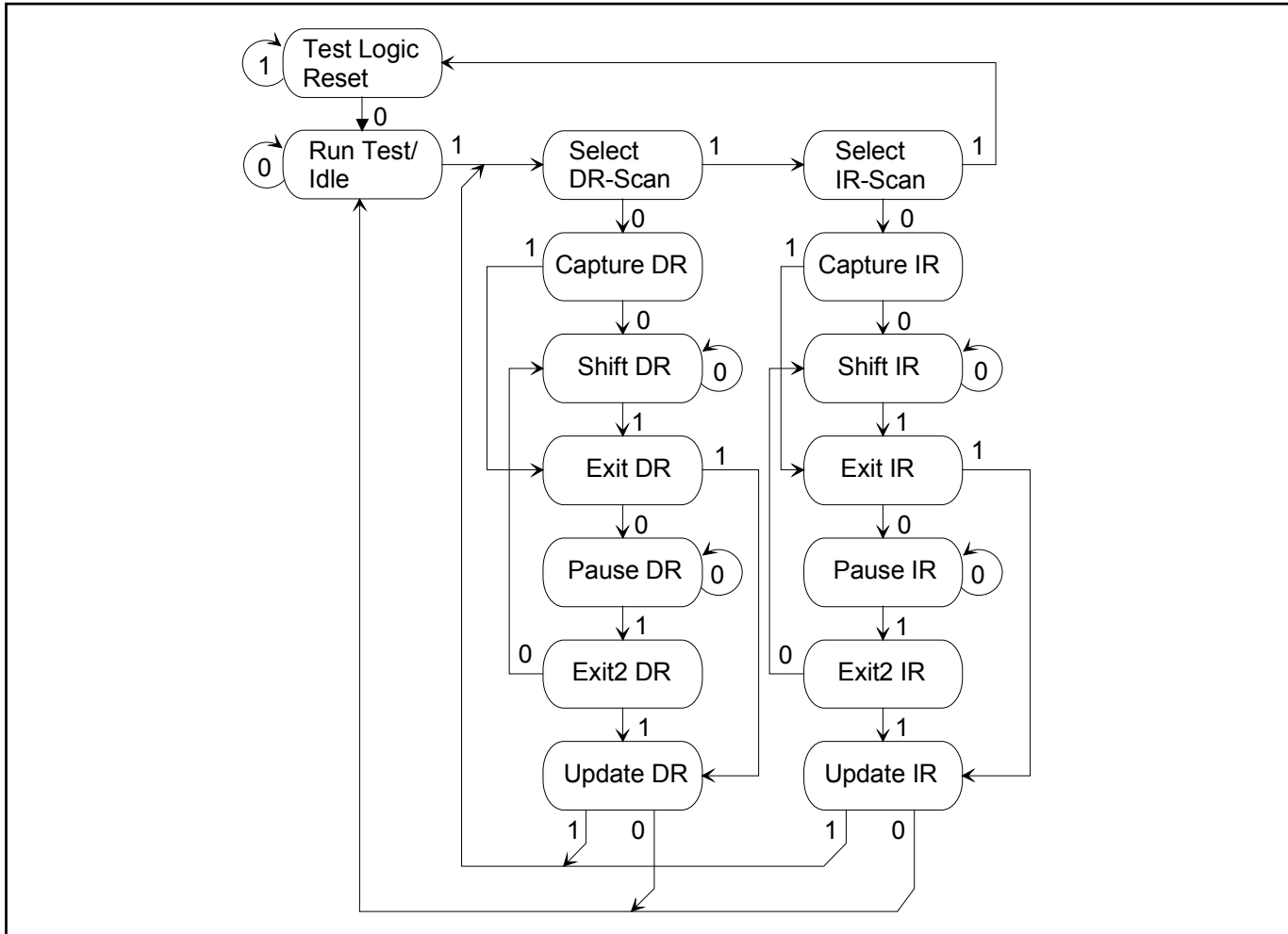

**Capture-DR.** Data can be parallel-loaded into the test data registers selected by the current instruction. If the instruction does not call for a parallel load or the selected register does not allow parallel loads, the test register remains at its current value. On the rising edge of JTCLK, the controller goes to the shift-DR state if JTMS is LOW, or it goes to the exit1-DR state if JTMS is HIGH.

**Shift-DR.** The test data register selected by the current instruction is connected between JTDI and JTDO, and shifts data one stage toward its serial output on each rising edge of JTCLK. If a test register selected by the current instruction is not placed in the serial path, it maintains its previous state.

**Exit1-DR.** While in this state, a rising edge on JTCLK puts the controller in the update-DR state, which terminates the scanning process, if JTMS is HIGH. A rising edge on JTCLK with JTMS LOW puts the controller in the pause-DR state.

**Pause-DR.** Shifting of the test registers is halted while in this state. All test registers selected by the current instruction retain their previous state. The controller remains in this state while JTMS is LOW. A rising edge on JTCLK with JTMS HIGH puts the controller in the exit2-DR state.

**Exit2-DR.** A rising edge on JTCLK with JTMS HIGH while in this state puts the controller in the update-DR state and terminates the scanning process. A rising edge on JTCLK with JTMS LOW enters the shift-DR state.

**Update-DR.** A falling edge on JTCLK while in the update-DR state latches the data from the shift register path of the test registers into the data output latches. This prevents changes at the parallel output due to changes in the shift register.

**Select-IR-Scan.** All test registers retain their previous state. The instruction register remains unchanged during this state. With JTMS LOW, a rising edge on JTCLK moves the controller into the capture-IR state and initiates a scan sequence for the instruction register. JTMS HIGH during a rising edge on JTCLK puts the controller back into the test-logic-reset state.

**Capture-IR.** The capture-IR state is used to load the shift register in the instruction register with a fixed value. This value is loaded on the rising edge of JTCLK. If JTMS is HIGH on the rising edge of JTCLK, the controller enters the exit1-IR state. If JTMS is LOW on the rising edge of JTCLK, the controller enters the shift-IR state.

**Shift-IR.** In this state, the shift register in the instruction register is connected between JTDI and JTDO and shifts data one stage for every rising edge of JTCLK toward the serial output. The parallel register and all test registers remain at their previous states. A rising edge on JTCLK with JTMS HIGH moves the controller to the exit1-IR state. A rising edge on JTCLK with JTMS LOW keeps the controller in the shift-IR state while moving data one stage through the instruction shift register.

**Exit1-IR.** A rising edge on JTCLK with JTMS LOW puts the controller in the pause-IR state. If JTMS is HIGH on the rising edge of JTCLK, the controller enters the update-IR state and terminates the scanning process.

**Pause-IR.** Shifting of the instruction shift register is halted temporarily. With JTMS HIGH, a rising edge on JTCLK puts the controller in the exit2-IR state. The controller remains in the pause-IR state if JTMS is LOW during a rising edge on JTCLK.

**Exit2-IR.** A rising edge on JTCLK with JTMS HIGH puts the controller in the update-IR state. The controller loops back to shift-IR if JTMS is LOW during a rising edge of JTCLK in this state.

**Update-IR.** The instruction code shifted into the instruction shift register is latched into the parallel output on the falling edge of JTCLK as the controller enters this state. Once latched, this instruction becomes the current instruction. A rising edge on JTCLK with JTMS LOW puts the controller in the run-test-idle state. With JTMS HIGH, the controller enters the select-DR-scan state.

## 8.2 Instruction Register

The instruction register contains a shift register, as well as a latched parallel output, and is 3 bits in length. When the TAP controller enters the shift-IR state, the instruction shift register is connected between JTDI and JTDO. While in the shift-IR state, a rising edge on JTCLK with JTMS LOW shifts the data one stage toward the serial output at JTDO. A rising edge on JTCLK in the exit1-IR state or the exit2-IR state with JTMS HIGH moves the controller to the update-IR state. The falling edge of that same JTCLK latches the data in the instruction shift register to the instruction parallel output. [Table 8-A](#) shows the instructions supported by the DS21448 and its respective operational binary codes.

**Table 8-A. Instruction Codes for IEEE 1149.1 Architecture**

INSTRUCTION	SELECTED REGISTER	INSTRUCTION CODES
SAMPLE/PRELOAD	Boundary Scan	010
BYPASS	Bypass	111
EXTEST	Boundary Scan	000
CLAMP	Bypass	011
HIGHZ	Bypass	100
IDCODE	Device Identification	001

**SAMPLE/PRELOAD.** This is a mandatory instruction for the IEEE 1149.1 specification that supports two functions. The digital I/Os of the device can be sampled at the boundary scan register without interfering with the normal operation of the device by using the capture-DR state. SAMPLE/PRELOAD also allows the device to shift data into the boundary scan register through JTDI using the shift-DR state.

**BYPASS.** When the BYPASS instruction is latched into the parallel instruction register, JTDI connects to JTDO through the 1-bit bypass test register. This allows data to pass from JTDI to JTDO without affecting the device's normal operation.

**EXTEST.** This allows testing of all interconnections to the device. When the EXTEST instruction is latched in the instruction register, the following actions occur. Once enabled through the update-IR state, the parallel outputs of all digital output pins are driven. The boundary scan register is connected between JTDI and JTDO. The capture-DR samples all digital inputs into the boundary scan register.

**CLAMP.** All digital outputs of the device are output data from the boundary scan parallel output while connecting the bypass register between JTDI and JTDO. The outputs do not change during the CLAMP instruction.

**HIGHZ.** All digital outputs of the device are placed in a high-impedance state. The BYPASS register is connected between JTDI and JTDO.

**IDCODE.** When the IDCODE instruction is latched into the parallel instruction register, the identification test register is selected. The device identification code is loaded into the identification register on the rising edge of JTCLK following entry into the capture-DR state. Shift-DR can be used to shift the identification code out serially through JTDO. During test-logic-reset, the identification code is forced into the instruction register's parallel output. The ID code always has a 1 in the LSB position. The next 11 bits identify the manufacturer's JEDEC number and number of continuation bytes followed by 16 bits for the device and 4 bits for the version [Table 8-B](#). [Table 8-C](#) lists the device ID code for the SCT devices.

**Table 8-B. ID Code Structure**

MSB			LSB
Version (Contact Factory)	Device ID	JEDEC	1
4 bits	16 bits	00010100001	1

**Table 8-C. Device ID Codes**

DEVICE	16-BIT ID
DS21448	0018

### 8.3 Test Registers

IEEE 1149.1 requires a minimum of two test registers—the bypass register and the boundary scan register. An optional test register, the identification register, has been included with the DS21448 design. It is used with the IDCODE instruction and the test-logic-reset state of the TAP controller.

#### Bypass Register

The bypass register is a single 1-bit shift register used with the BYPASS, CLAMP, and HIGHZ instructions that provides a short path between JTDI and JTDO.

#### Identification Register

The identification register contains a 32-bit shift register and a 32-bit latched parallel output. This register is selected during the IDCODE instruction and when the TAP controller is in the test-logic-reset state. See [Table 8-B](#) and [Table 8-C](#) for more information about bit usage.

#### Boundary Scan Register

The boundary scan register contains a shift register path and a latched parallel output for all control cells and digital I/O cells, and is n bits in length. See [Table 8-D](#) for all cell bit locations and definitions.

Table 8-D. Boundary Scan Control Bits

BIT	PIN		NAME	I/O
	BGA	LQFP		
—	A1	124	RTIP1	I
—	A2	6	TTIP1	O
—	A4	28	RTIP2	I
—	A5	38	TTIP2	O
—	A7	60	RTIP3	I
—	A8	71	TTIP3	O
—	A10	93	RTIP4	I
—	A11	102	TTIP4	O
—	B2	125	RRING1	I
—	B3	9	TRING1	O
—	B5	29	RRING2	I
—	B6	41	TRING2	O
—	B8	61	RRING3	I
—	B9	74	TRING3	O
—	B11	94	RRING4	I
—	B12	105	TRING4	O
—	D1	39	TVSS2	—
—	D2	40	TVDD2	—
64	D3	57	CS2	I
48	D4	80	D2/AD2	I/O
46	D5	82	D0/AD0	I/O
67	D6	47	BPCLK2	O
22	D7	128	RCL/LOT2	O
—	D8	49–51	VDD3	—
—	D9	52–54	VSS3	—
44	D10	84	CS3	I
15	D11	14	RPOS3	O
3	D12	34	TNEG3	I
17	E1	12	RPOS2	O
16	E2	13	RNEG2	O
49	E3	79	D3/AD3	I/O
—	E4	19–21	VDD2	—
—	E9	72	TVSS3	—
27	E10	121	PBEO3	O
63	E11	58	RCLK3	O
4	E12	33	TPOS3	I
6	F1	31	RCLK2	O
7	F2	30	TPOS2	I
47	F3	81	D1/AD1	I/O
—	F4	22–24	VSS2	—
21	F9	1	RCL/LOT3	O
65	F10	56	BPCLK3	O
14	F11	15	RNEG3	O
45	F12	83	TCLK3	I
9	G1	26	TPOS1	I
18	G2	11	RNEG1	O
31	G3	111	PBEO2	O
—	G9	73	TVDD3	—
51	G11	77	D5/AD5	I/O

BIT	PIN		NAME	I/O
	BGA	LQFP		
54 (Note 1)	—		BUScntl	—
56	G12	66	A0	I
42	H1	92	WR (R/W)	I
8	H2	27	TNEG1	I
23	H3	127	RCLK1	O
26	H4	122	BPCLK1	O
—	H9	88–90	VSS4	—
52	H10	76	D6/AD6	I/O
58	H11	64	A2	I
57	H12	65	A1	I
2	J1	35	SCLK	I
43	J2	91	RD (DS)	I
11	J3	18	CS1	I
—	J4	7	TVSS1	—
—	J5	8	TVDD1	—
33	J6	109	MCLK	I
20	J7	2	RCL/LOT4	O
—	J8	85–87	VDD4	—
50	J9	78	D4/AD4	I/O
53	J10	75	D7/AD7	I/O
60	K1	62	A4	I
41	K2	95	ALE (AS)	I
1	K3	36	SDI	I
19	K4	10	RPOS1	O
32	K5	110	PBEO1	O
37	K7	98	TXDIS/TEST	I
25	K8	123	PBEO4	O
39 (Note 2)	—		INTcntl	—
38	K9	97	INT	I/O
28	K10	114	CS4	I
13	K11	16	RPOS4	O
62	K12	59	TNEG4	I
59	L1	63	A3	I
0	L2	43	TCLK2	I
—	L3	42	JTRST	I
—	L5	115–117	VDD1	—
24	L6	126	RCL/LOT1	O
35	L7	107	BIS0	I
30	L8	112	BPCLK4	O
36	L9	106	HRST	I
—	L10	103	TVSS4	—
40	L11	96	RCLK4	O
29	L12	113	TCLK4	I
5	M1	32	TNEG2	I
12	M2	17	TCLK1	I
—	M3	48	JTMS	I
—	M4	118–120	VSS1	—
—	M5	44	JTCLK	I

BIT	PIN		NAME	I/O
	BGA	LQFP		
—	M6	45	JTDI	I
—	M7	46	JTDO	O
55	M8	68	BIS1	I
—	M9	104	TVDD4	—

BIT	PIN		NAME	I/O
	BGA	LQFP		
10	M10	25	RNEG4	O
61	—	—	ADRSctl	—
66	M11	55	TPOS4	I
34	M12	108	PBTS	I

**Note 1:** 0 = Dn/ADn are inputs; 1 = Dn/ADn are outputs.

**Note 2:** 0 =  $\overline{\text{INT}}$  is an input; 1 =  $\overline{\text{INT}}$  is an output.

## 9. OPERATING PARAMETERS

### ABSOLUTE MAXIMUM RATINGS

Voltage Range on Any Pin Relative to Ground  
 Operating Temperature Range for DS21448TN  
 Storage Temperature Range  
 Soldering Temperature

-1.0V to +6.0V  
 -40°C to +85°C  
 -55°C to +125°C

See IPC/JEDEC J-STD-020 Specification

*Stresses beyond those listed under "Absolute Maximum Ratings" may cause permanent damage to the device. These are stress ratings only, and functional operation of the device at these or any other conditions beyond those indicated in the operational sections of the specifications is not implied. Exposure to the absolute maximum rating conditions for extended periods may affect device reliability.*

### RECOMMENDED DC OPERATING CONDITIONS

( $T_A = -40^\circ\text{C}$  to  $+85^\circ\text{C}$ )

PARAMETER	SYMBOL	CONDITIONS	MIN	TYP	MAX	UNITS
Logic 1	$V_{IH}$		2.2		5.5	V
Logic 0	$V_{IL}$		-0.3		+0.8	V
Supply for 3.3V Operation	$V_{DD}$	(Note 1)	3.135	3.3	3.465	V

### CAPACITANCE

( $T_A = +25^\circ\text{C}$ )

PARAMETER	SYMBOL	CONDITIONS	MIN	TYP	MAX	UNITS
Input Capacitance	$C_{IN}$			5		pF
Output Capacitance	$C_{OUT}$			7		pF

### DC CHARACTERISTICS

( $V_{DD} = 3.3\text{V} \pm 5\%$ ,  $T_A = -40^\circ\text{C}$  to  $+85^\circ\text{C}$ .)

PARAMETER	SYMBOL	CONDITIONS	MIN	TYP	MAX	UNITS
Input Leakage	$I_{IL}$	(Note 2)	-1.0		+1.0	$\mu\text{A}$
Output Leakage	$I_{LO}$	(Note 3)			+1.0	$\mu\text{A}$
Output Current (2.4V)	$I_{OH}$		-1.0			mA
Output Current (0.4V)	$I_{OL}$		+4.0			mA
Supply Current at 3.3V	$I_{DD}$	(Notes 4, 5)		320	400	mA
Power Dissipation at 3.3V	$P_{DD}$	(Notes 4, 5)		1.06	1.32	W

**Note 1:** Applies to  $V_{DD}$ .

**Note 2:**  $0.0\text{V} < V_{IN} < V_{DD}$ .

**Note 3:** Applied to  $\overline{\text{INT}}$  when tri-stated.

**Note 4:**  $\text{TCLK} = \text{MCLK} = 2.048\text{MHz}$ .

**Note 5:** Power dissipation with all ports active, TTIP and TRING driving a  $30\Omega$  load, for an all-ones data density.

## 10. AC TIMING PARAMETERS AND DIAGRAMS

**Table 10-A. AC Characteristics—Multiplexed Parallel Port (BIS0 = 0)**

( $V_{DD} = 3.3V \pm 5\%$ ,  $T_A = -40^{\circ}C$  to  $+85^{\circ}C$ .) (Figure 10-1, Figure 10-2, and Figure 10-3)

PARAMETER	SYMBOL	CONDITIONS	MIN	TYP	MAX	UNITS
Cycle Time	$t_{CYC}$		200			ns
Pulse Width, DS Low or $\overline{RD}$ High	$PW_{EL}$		100			ns
Pulse Width, DS High or $\overline{RD}$ Low	$PW_{EH}$		100			ns
Input Rise/Fall Times	$t_R, t_F$				20	ns
R/ $\overline{W}$ Hold Time	$t_{RWH}$		10			ns
R/ $\overline{W}$ Setup Time Before DS High	$t_{RWS}$		50			ns
$\overline{CS}$ Setup Time Before DS, $\overline{WR}$ , or $\overline{RD}$ Active	$t_{CS}$		20			ns
$\overline{CS}$ Hold Time	$t_{CH}$		0			ns
Read Data Hold Time	$t_{DHR}$		10		50	ns
Write Data Hold Time	$t_{DHW}$		5			ns
Muxed Address Valid to AS or ALE Fall	$t_{ASL}$		15			ns
Muxed Address Hold Time	$t_{AHL}$		10			ns
Delay Time DS, $\overline{WR}$ , or $\overline{RD}$ to AS or ALE Rise	$t_{ASD}$		20			ns
Pulse Width AS or ALE High	$PW_{ASH}$		30			ns
Delay Time, AS or ALE to DS, $\overline{WR}$ , or $\overline{RD}$	$t_{ASED}$		10			ns
Output Data Delay Time from DS or $\overline{RD}$	$t_{DDR}$		20		80	ns
Data Setup Time	$t_{DSW}$		50			ns

**Figure 10-1. Intel Bus Read Timing (PBTS = 0, BIS0 = 0)**

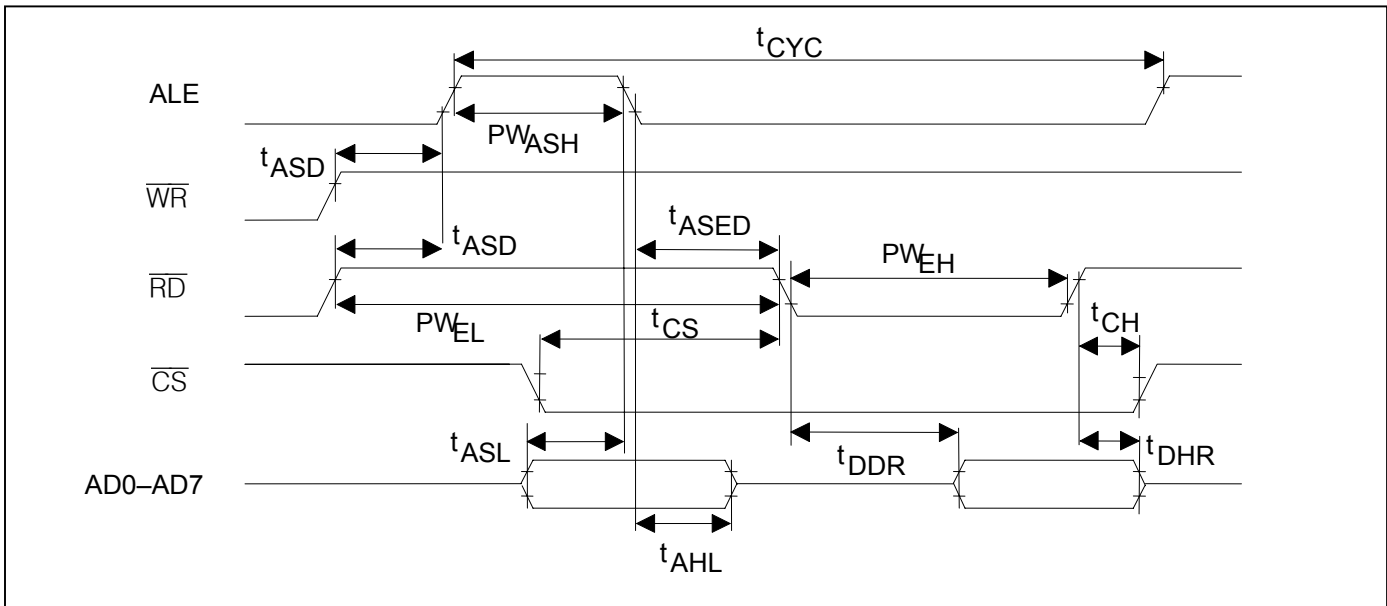

**Figure 10-2. Intel Bus Write Timing (PBTS = 0, BIS0 = 0)**

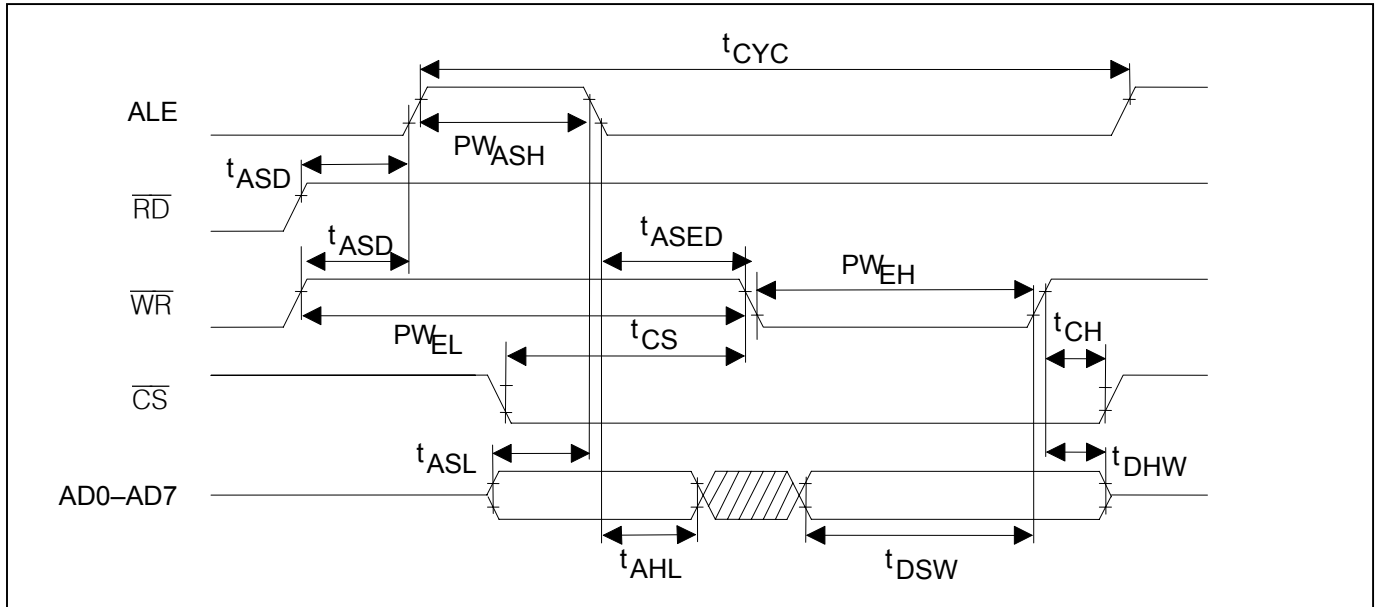

**Figure 10-3. Motorola Bus Timing (PBTS = 1, BIS0 = 0)**

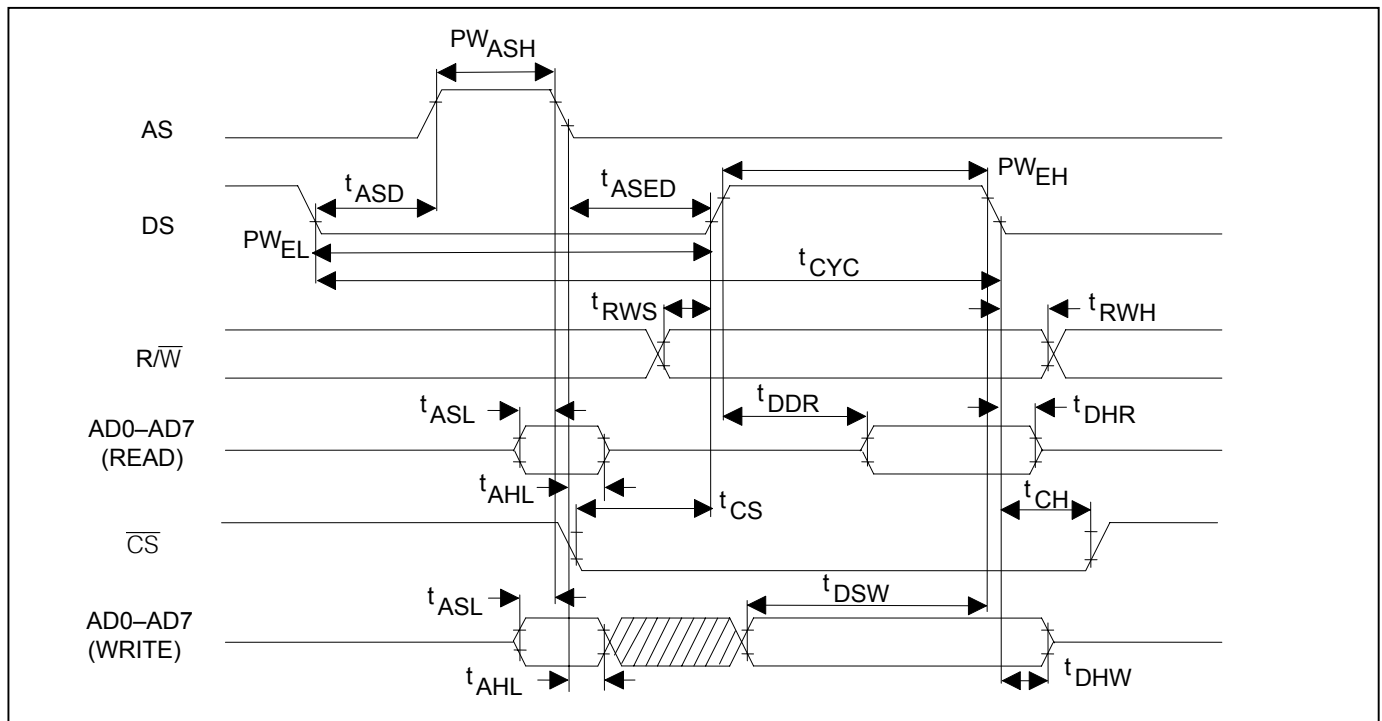
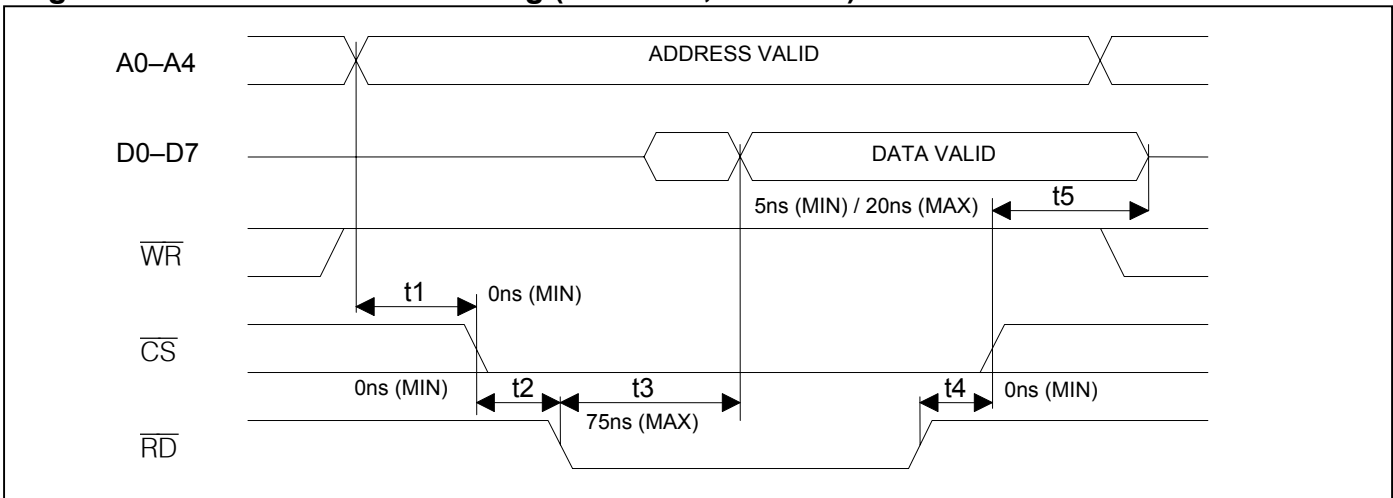

**Table 10-B. AC Characteristics—Nonmultiplexed Parallel Port (BIS0 = 1)**

( $V_{DD} = 3.3V \pm 5\%$ ,  $T_A = -40^\circ C$  to  $+85^\circ C$ .) (Figure 10-4, Figure 10-5, Figure 10-6, and Figure 10-7)

PARAMETER	SYMBOL	CONDITIONS	MIN	TYP	MAX	UNITS
Setup Time for A0 to A4, Valid to $\overline{CS}$ Active	t1		0			ns
Setup Time for $\overline{CS}$ Active to Either $\overline{RD}$ , $\overline{WR}$ , or $\overline{DS}$ Active	t2		0			ns
Delay Time from Either $\overline{RD}$ or $\overline{DS}$ Active to Data Valid	t3				75	ns
Hold Time from Either $\overline{RD}$ , $\overline{WR}$ , or $\overline{DS}$ Inactive to $\overline{CS}$ Inactive	t4		0			ns
Hold Time from $\overline{CS}$ Inactive to Data Bus Tri-State	t5		5.0		20	ns
Wait Time from Either $\overline{WR}$ or $\overline{DS}$ Active to Latch Data	t6		75			ns
Data Setup Time to Either $\overline{WR}$ or $\overline{DS}$ Inactive	t7		10			ns
Data Hold Time from Either $\overline{WR}$ or $\overline{DS}$ Inactive	t8		10			ns
Address Hold from Either $\overline{WR}$ or $\overline{DS}$ Inactive	t9		10			ns

**Figure 10-4. Intel Bus Read Timing (PBTS = 0, BIS0 = 1)**



**Figure 10-5. Intel Bus Write Timing (PBTS = 0, BIS0 = 1)**

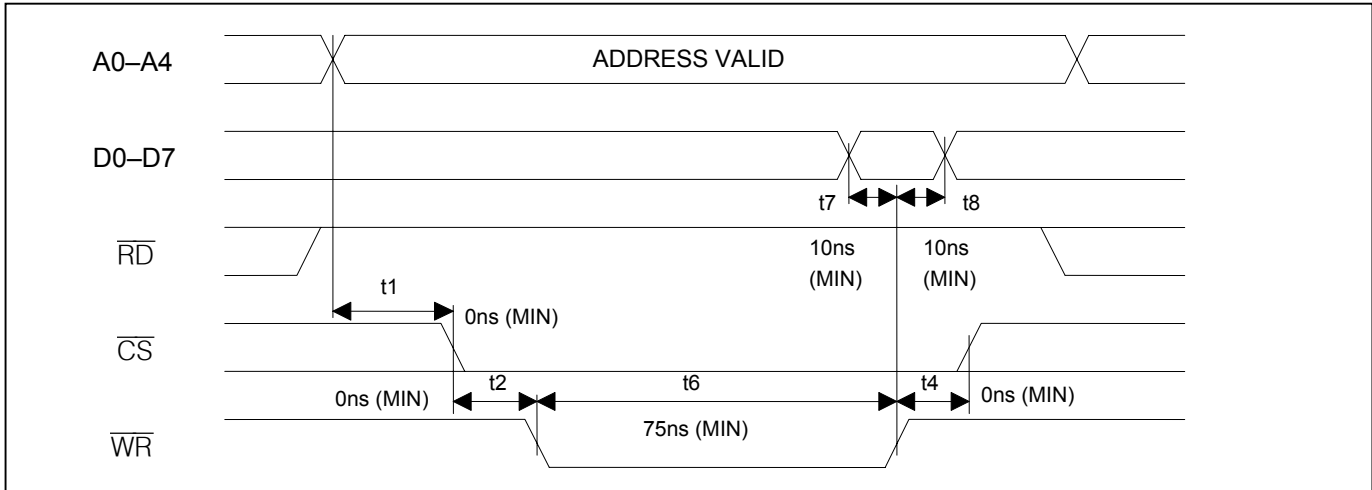

**Figure 10-6. Motorola Bus Read Timing (PBTS = 1, BIS0 = 1)**

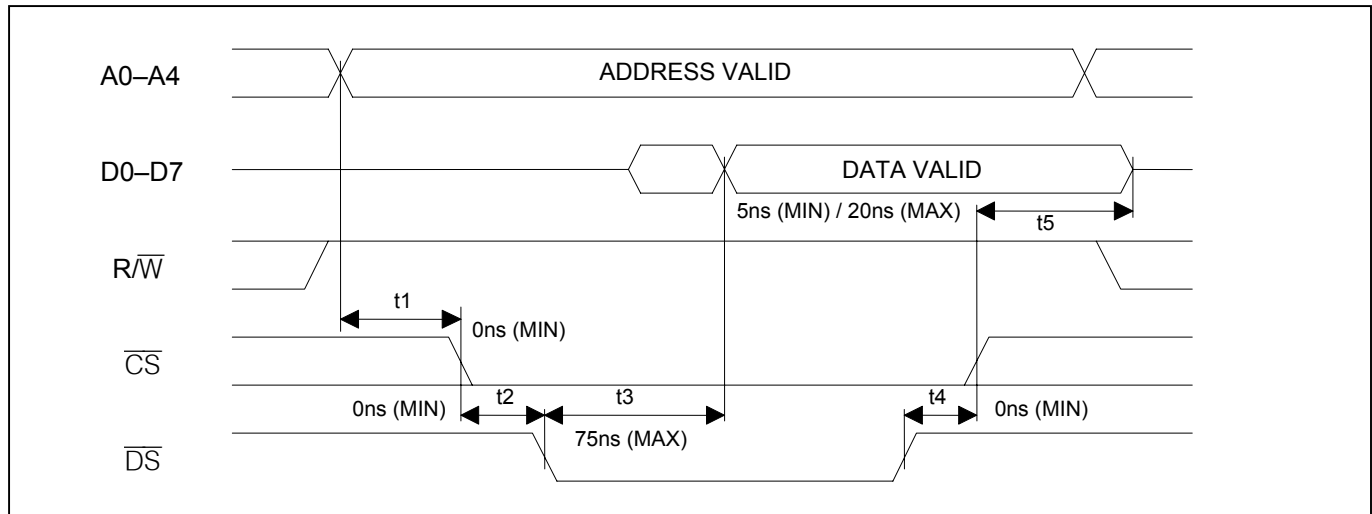

**Figure 10-7. Motorola Bus Write Timing (PBTS = 1, BIS0 = 1)**

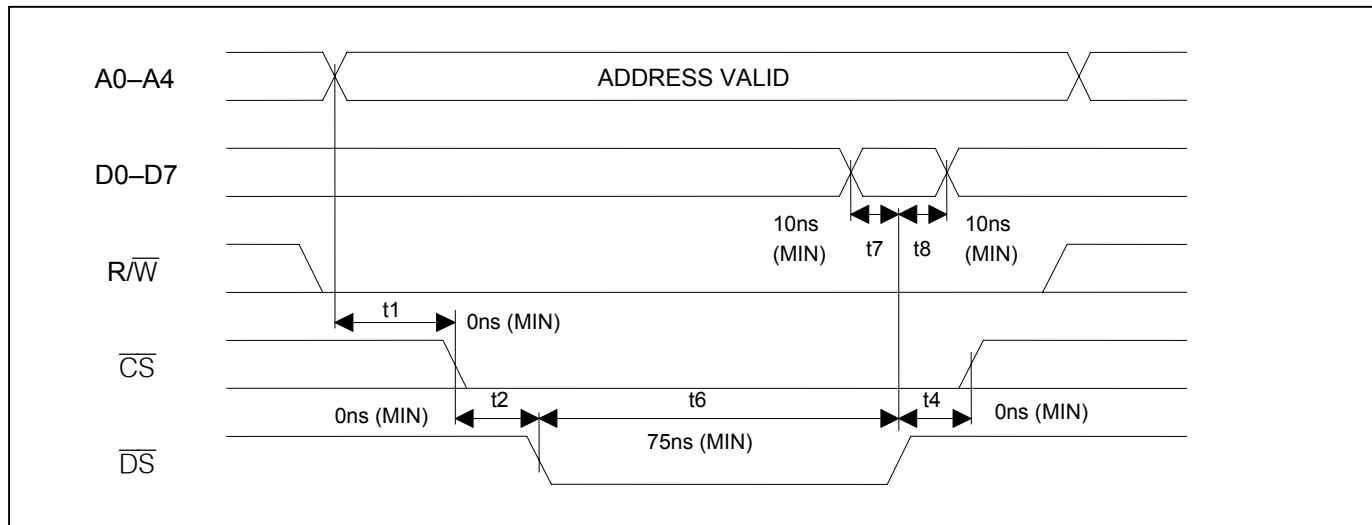
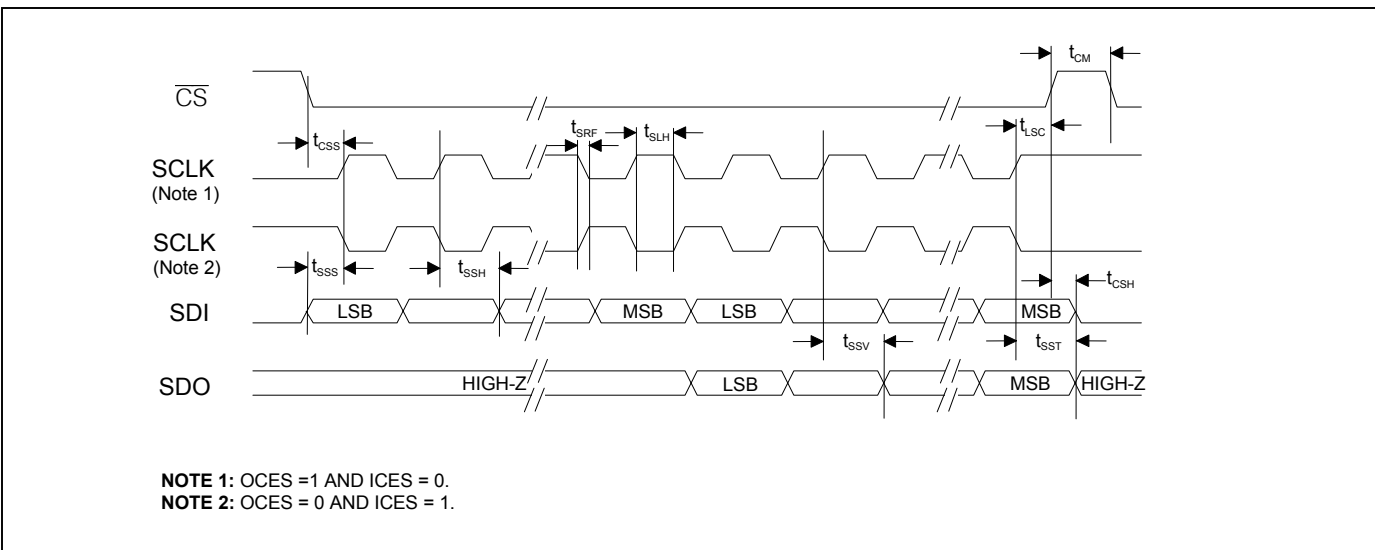

**Table 10-C. AC Characteristics—Serial Port (BIS1 = 1, BIS0 = 0)**

( $V_{DD} = 3.3V \pm 5\%$ ,  $T_A = -40^{\circ}C$  to  $+85^{\circ}C$ .) (Figure 10-8)

PARAMETER	SYMBOL	CONDITIONS	MIN	TYP	MAX	UNITS
Setup Time $\overline{CS}$ to SCLK	$t_{CSS}$		50			ns
Setup Time SDI to SCLK	$t_{SSS}$		50			ns
Hold Time SCLK to SDI	$t_{SSH}$		50			ns
SCLK High/Low Time	$t_{SLH}$		200			ns
SCLK Rise/Fall Time	$t_{SRF}$				50	ns
SCLK to $\overline{CS}$ Inactive	$t_{LSC}$		50			ns
$\overline{CS}$ Inactive Time	$t_{CM}$		250			ns
SCLK to SDO Valid	$t_{SSV}$				50	ns
SCLK to SDO Tri-State	$t_{SST}$			100		ns
$\overline{CS}$ Inactive to SDO Tri-State	$t_{CSH}$			100		ns

**Figure 10-8. Serial Bus Timing (BIS1 = 1, BIS0 = 0)**



**Table 10-D. AC Characteristics—Receive Side**

( $V_{DD} = 3.3V \pm 5\%$ ,  $T_A = -40^\circ C$  to  $+85^\circ C$ .) (Figure 10-9)

PARAMETER	SYMBOL	CONDITIONS	MIN	TYP	MAX	UNITS
RCLK Period	$t_{CP}$	(Note 1)		488		ns
		(Note 2)		648		
RCLK Pulse Width	$t_{CH}$	(Note 3)	200			ns
	$t_{CL}$					
RCLK Pulse Width	$t_{CH}$	(Note 4)	150			ns
	$t_{CL}$					
Delay RCLK to RPOS, RNEG, PBE0, RBPV Valid	$t_{DD}$				50.0	ns

- Note 1:** E1 mode.
- Note 2:** T1 or J1 mode.
- Note 3:** Jitter attenuator enabled in the receive path.
- Note 4:** Jitter attenuator disabled or enabled in the transmit path.

**Figure 10-9. Receive-Side Timing**

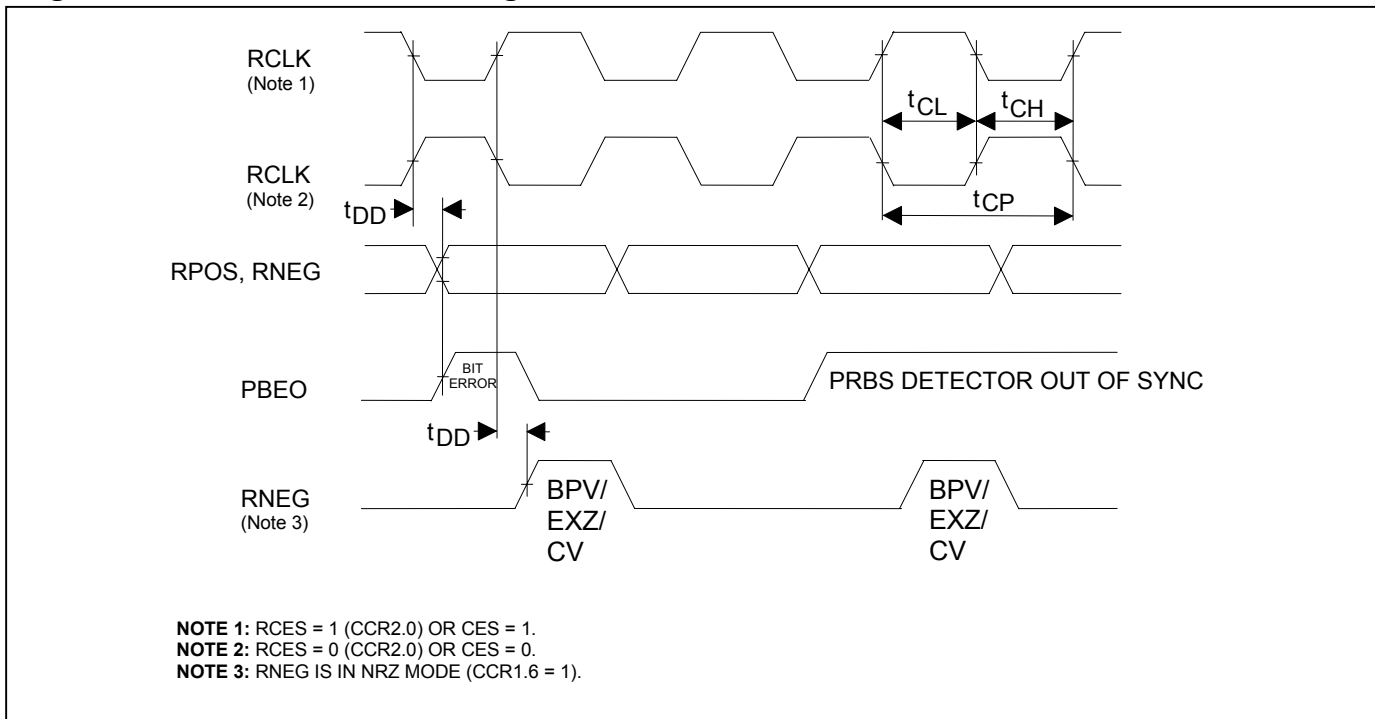

**Table 10-E. AC Characteristics—Transmit Side**

( $V_{DD} = 3.3V \pm 5\%$ ,  $T_A = -40^\circ C$  to  $+85^\circ C$ .) (Figure 10-10)

PARAMETER	SYMBOL	CONDITIONS	MIN	TYP	MAX	UNITS
TCLK Period	$t_{CP}$	(Note 5)		488		ns
		(Note 6)		648		
TCLK Pulse Width	$t_{CH}$		75			ns
	$t_{CL}$		75			
TPOS/TNEG Setup to TCLK Falling or Rising	$t_{SU}$		20			ns
TPOS/TNEG Hold from TCLK Falling or Rising	$t_{HD}$		20			ns
TCLK Rise and Fall Times	$t_R, t_F$				25	ns

**Note 5:** E1 mode.

**Note 6:** T1 or J1 mode.

**Figure 10-10. Transmit-Side Timing**

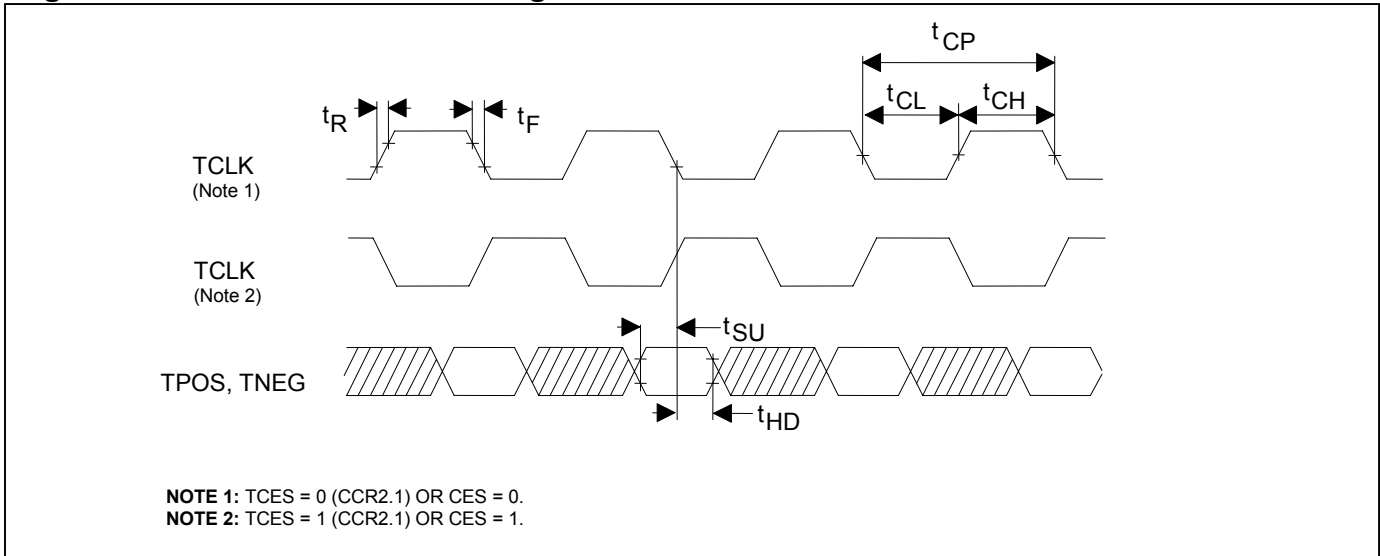

## 11. PIN CONFIGURATIONS

### 11.1 144-Pin TE-PBGA

	1	2	3	4	5	6	7	8	9	10	11	12
<b>A</b>	RTIP1	TTIP1	N.C.	RTIP2	TTIP2	N.C.	RTIP3	TTIP3	N.C.	RTIP4	TTIP4	N.C.
<b>B</b>	N.C.	RRING1	TRING1	N.C.	RRING2	TRING2	N.C.	RRING3	TRING3	N.C.	RRING4	TRING4
<b>C</b>	N.C.	N.C.	N.C.	N.C.	N.C.	N.C.	N.C.	N.C.	N.C.	N.C.	N.C.	N.C.
<b>D</b>	TVSS2	TVDD2	$\overline{CS2}$	D2/ AD2	D0/ AD0	BPCLK2	RCL/ LOTC2	VDD3	VSS3	$\overline{CS3}$	RPOS3	TNEG3
<b>E</b>	RPOS2	RNEG2	D3/ AD3	VDD2	N.C.	N.C.	N.C.	N.C.	TVSS3	PEBO3	RCLK3	TPOS3
<b>F</b>	RCLK2	TPOS2	D1/ AD1	VSS2	N.C.	N.C.	N.C.	N.C.	RCL/ LOTC3	BPCLK3	RNEG3	TCLK3
<b>G</b>	TPOS1	RNEG1	PEBO2	N.C.	N.C.	N.C.	N.C.	N.C.	TVDD3	N.C.	D5/ AD5	A0
<b>H</b>	$\overline{WR}$ (R/W)	TNEG1	RCLK1	BPCLK1	N.C.	N.C.	N.C.	N.C.	VSS4	D6/ AD6	A2/ OCES	A1
<b>J</b>	SCLK	$\overline{RD}$ ( $\overline{DS}$ )	$\overline{CS1}$	TVSS1	TVDD1	MCLK	RCL/ LOTC4	VDD4	D4/ AD4	D7/ AD7	N.C.	N.C.
<b>K</b>	A4/ SDO	ALE (AS)	SDI	RPOS1	PEBO1	N.C.	TXDIS/ TEST	PEBO4	$\overline{INT}$	$\overline{CS4}$	RPOS4	TNEG4
<b>L</b>	A3/ ICES	TCLK2	JTRST	N.C.	VDD1	RCL/ LOTC1	BIS0	BPCLK4	$\overline{HRST}$	TVSS4	RCLK4	TCLK4
<b>M</b>	TNEG2	TCLK1	JTMS	VSS1	JTCLK	JTDI	JTDO	BIS1	TVDD4	RNEG4	TPOS4	PBTS



## 12. PACKAGE INFORMATION

(The package drawing(s) in this data sheet may not reflect the most current specifications. The package number provided for each package is a link to the latest package outline information.)

### 12.1 144-Ball TE-PBGA (56-G6020-001)

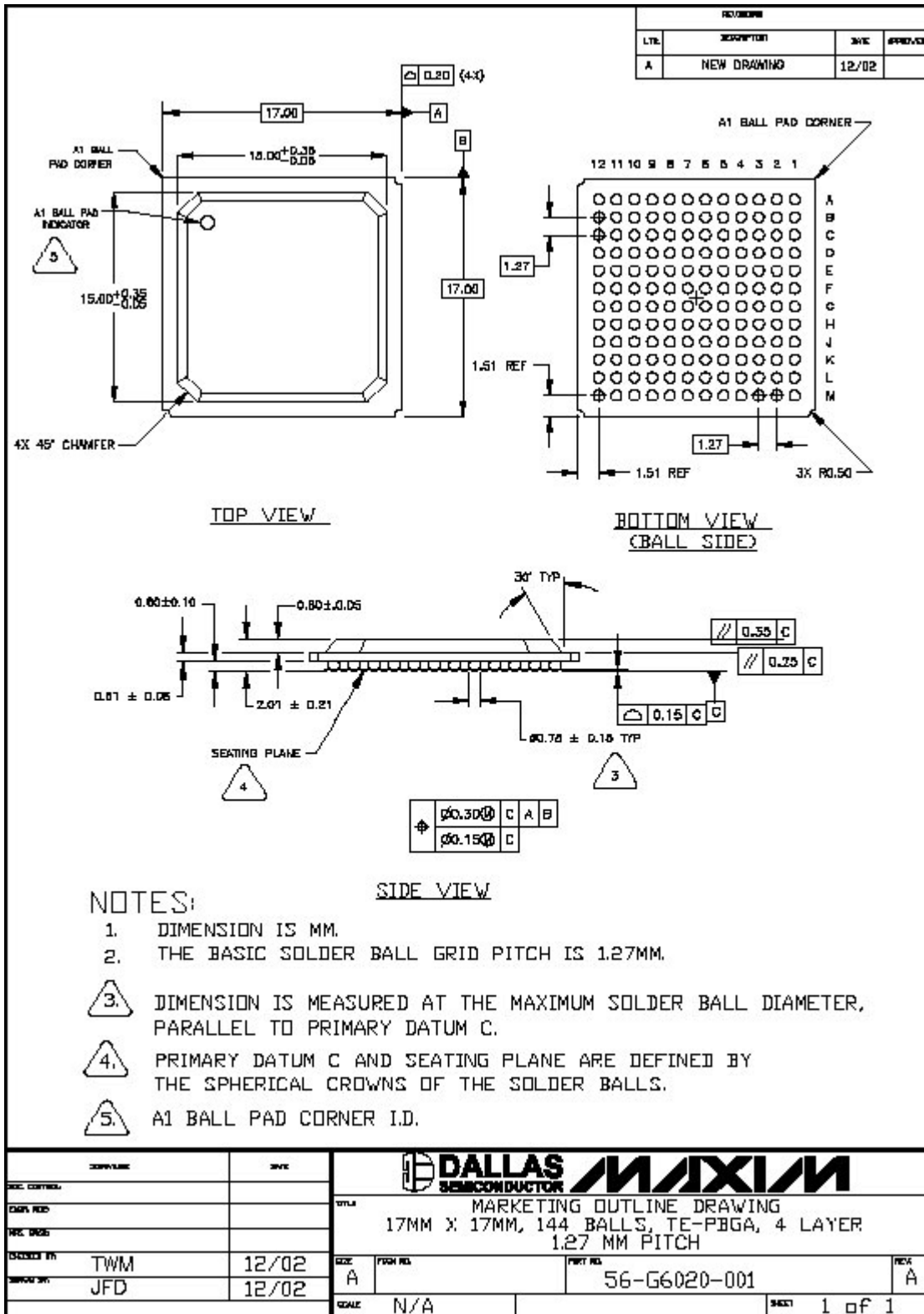

12.2 128-Pin LQFP (56-G4011-001)

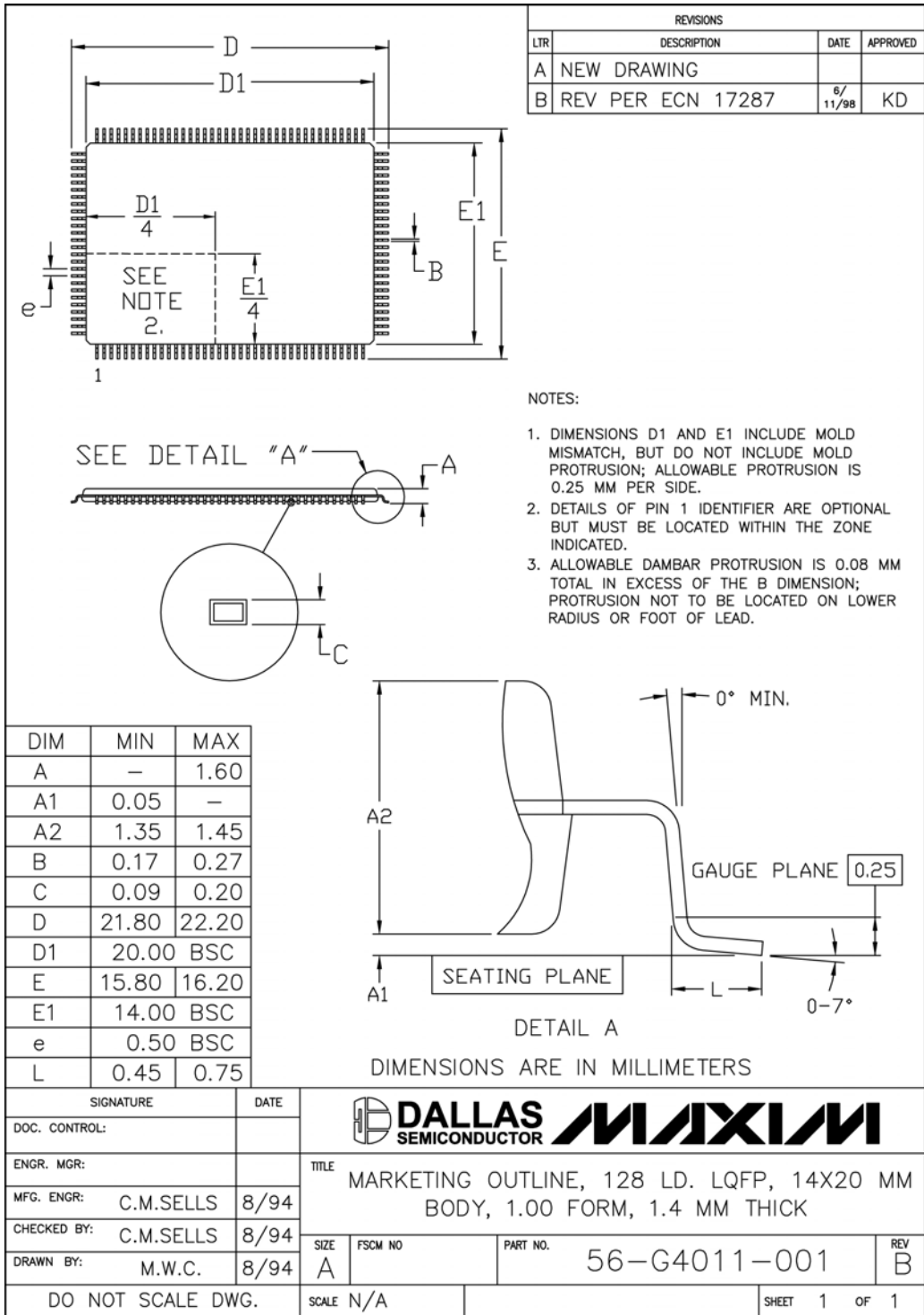

## 13. THERMAL INFORMATION

**Table 13-A. Thermal Characteristics—BGA**

PARAMETER	MIN	TYP	MAX	UNITS
Ambient Temperature (Note 1)	-40		+85	°C
Junction Temperature			+125	°C
Theta-JA ( $\theta_{JA}$ ) in Still Air (Note 2)		+24		°C/W

**Table 13-B. Theta-JA ( $\theta_{JA}$ ) vs. Airflow—BGA**

FORCED AIR (m/s)	THETA-JA ( $\theta_{JA}$ )
0	24°C/W
1	21°C/W
2.5	19°C/W

**Table 13-C. Thermal Characteristics—LQFP**

PARAMETER	MIN	TYP	MAX	UNITS
Ambient Temperature (Note 1)	-40		+85	°C
Junction Temperature			+125	°C
Theta-JA ( $\theta_{JA}$ ) in Still Air (Note 2)		+27.8		°C/W
Theta-JC ( $\theta_{JC}$ ) in Still Air (Note 3)		+0.1		°C/W

**Table 13-D. Theta-JA ( $\theta_{JA}$ ) vs. Airflow—LQFP**

FORCED AIR (m/s)	THETA-JA ( $\theta_{JA}$ )
0	27.8°C/W
1	23.5°C/W
2.5	21.6°C/W

**Note 1:** The package is mounted on a four-layer JEDEC-standard test board.

**Note 2:** Theta-JA ( $\theta_{JA}$ ) is the junction-to-ambient thermal resistance, when the package is mounted on a four-layer JEDEC-standard test board.

**Note 3:** While Theta-JC ( $\theta_{JC}$ ) is commonly used as the thermal parameter that provides a correlation between the junction temperature ( $T_j$ ) and the average temperature on top center of the LQFP package ( $T_C$ ), the proper term is Psi-JT. It is defined by:  $(T_j - T_C) / \text{overall package power}$ .

**Note 4:** The method of measurement for the thermal parameters is defined in the EIA/JEDEC-standard document EIA-JESD51-2.

## 14. REVISION HISTORY

REVISION	DESCRIPTION
042303	New product release.
012104	<i>Table 5-B. Receive Level Indication:</i> Changed “-12.5 to -5.0” to “-12.5 to -15.0”. Adjusted steps after -17.5 dB to be in -2.5dB decrements. <i>Section 9, Operating Parameters:</i> Updated supply current and power dissipation values in the <i>DC Characteristics</i> table to reflect latest characterization data. Updated Note 5 to show that values are for all ports active.
113004	In the <i>Absolute Maximum Ratings</i> section, added range for storage temperature and changed soldering temperature from IPC JEDEC J-STD-020A to J-STD-020.
011206	Added lead-free packages to Ordering Information table.

## Looking for pricing, stock, or lifecycle information?

Click below to explore more details on WIN SOURCE:

 [View DS21448L on WIN SOURCE](#)

 [Maxim Integrated Information](#)

## Optimize Your Supply Chain with WIN SOURCE Solutions

-  Global Sourcing Solution
-  Obsolete Management
-  Cost Control Management
-  Shortage Management
-  Alternative Solution
-  Excess Inventory Management