



**THE DATASHEET OF
TPS2811QPWRQ1**



DUAL HIGH-SPEED MOSFET DRIVER

Check for Samples: [TPS2811-Q1](#)

FEATURES

- Qualified for Automotive Applications
- Industry-Standard Driver Replacement
- 25-ns Max Rise/Fall Times and 40-ns Max Propagation Delay With 1-nF Load, $V_{CC} = 14\text{ V}$
- 2-A Peak Output Current, $V_{CC} = 14\text{ V}$
- 5- μA Supply Current With Input High or Low
- 4-V to 14-V Supply-Voltage Range; Internal Regulator Extends Range to 40 V
- -40°C to 125°C Ambient-Temperature Operating Range

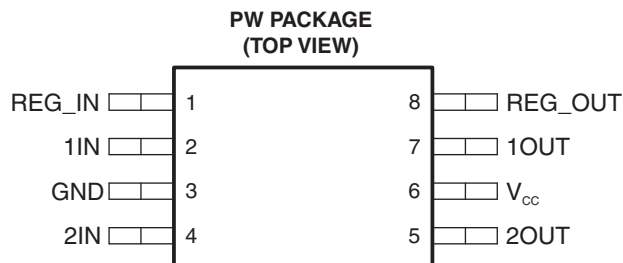

DESCRIPTION

The TPS2811 dual high-speed MOSFET driver is capable of delivering peak currents of 2 A into highly capacitive loads. This performance is achieved with a design that inherently minimizes shoot-through current and consumes an order of magnitude less supply current than competitive products.

The TPS2811 driver include a regulator to allow operation with supply inputs between 14 V and 40 V. The regulator output can power other circuitry, provided power dissipation does not exceed package limitations. When the regulator is not required, REG_IN and REG_OUT can be left disconnected or both can be connected to V_{CC} or GND.

TPS2811 driver is available in an 8-pin TSSOP package and operates over a ambient temperature range of -40°C to 125°C .

ORDERING INFORMATION⁽¹⁾

T_A	PACKAGE ⁽²⁾		ORDERABLE PART NUMBER	TOP-SIDE MARKING
-40°C to 125°C	TSSOP – PW	Reel of 2000	TPS2811QPWRQ1	2811Q

(1) For the most current package and ordering information, see the Package Option Addendum at the end of this document, or see the TI web site at www.ti.com.

(2) Package drawings, thermal data, and symbolization are available at www.ti.com/packaging.



Please be aware that an important notice concerning availability, standard warranty, and use in critical applications of Texas Instruments semiconductor products and disclaimers thereto appears at the end of this data sheet.

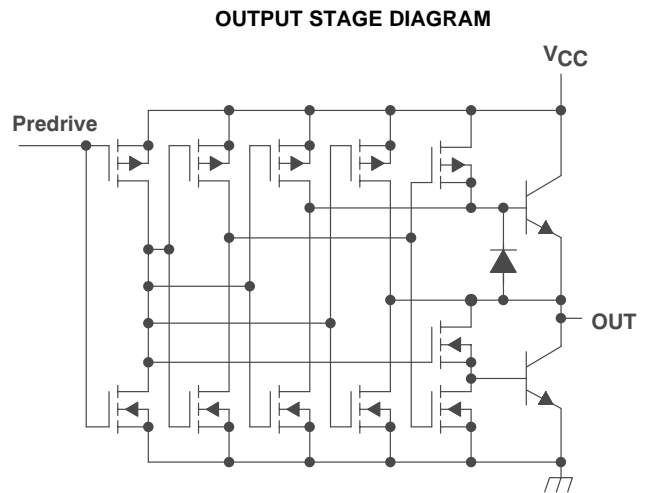
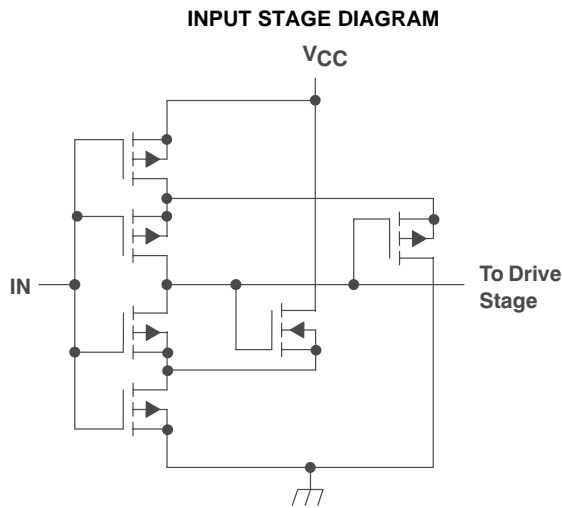
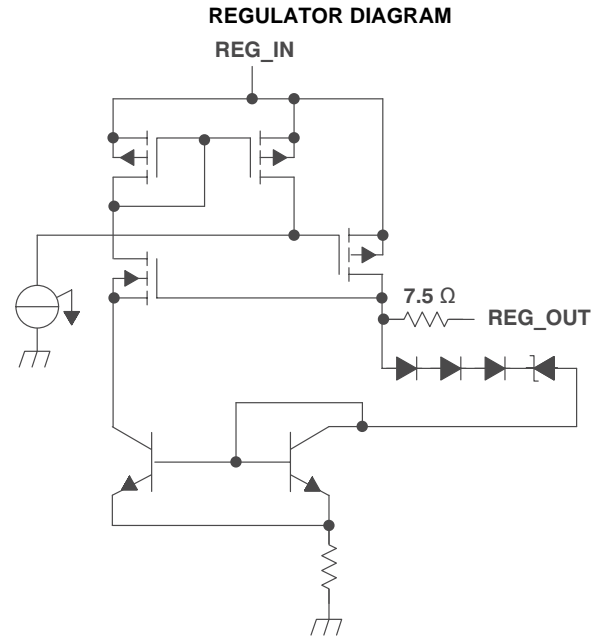
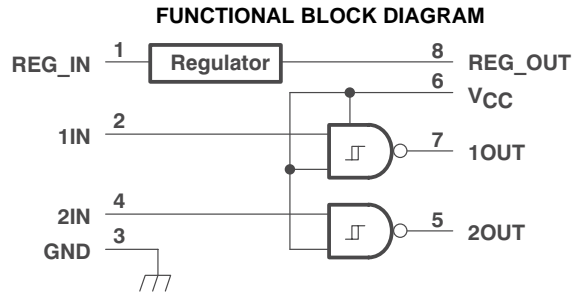

TERMINAL FUNCTIONS

TERMINAL		DESCRIPTION
NAME	NO.	
REG_IN	1	Regulator input
1IN	2	Input 1
GND	3	Ground
2IN	4	Input 2
2OUT	5	Output 2; $2OUT = \overline{2IN}$
V _{CC}	6	Supply voltage
1OUT	7	Output 1; $1OUT = \overline{1IN}$
REG_OUT	8	Regulator output

ABSOLUTE MAXIMUM RATINGS⁽¹⁾⁽²⁾

over operating free-air temperature range (unless otherwise noted)

V_{CC}	Supply voltage		-0.3 V to 15 V
	Regulator input voltage range	REG_IN	$V_{CC} - 0.3$ V to 42 V
	Input voltage range	1IN, 2IN	-0.3 V to $V_{CC} + 0.5$ V
	Output voltage range	1OUT, 2OUT	$-0.5 < V < V_{CC} + 0.5$ V
	Continuous regulator output current	REG_OUT	25 mA
	Continuous output current	1OUT, 2OUT	± 100 mA
T_A	Operating ambient temperature range		-40°C to 125°C
T_{stg}	Storage temperature range		-65°C to 150°C

- (1) Stresses beyond those listed under “absolute maximum ratings” may cause permanent damage to the device. These are stress ratings only, and functional operation of the device at these or any other conditions beyond those indicated under “recommended operating conditions” is not implied. Exposure to absolute-maximum-rated conditions for extended periods may affect device reliability.
- (2) All voltages are with respect to device GND pin.

RECOMMENDED OPERATING CONDITIONS

		MIN	MAX	UNIT
	Regulator input voltage	8	40	V
V_{CC}	Supply voltage	4	14	V
	Input voltage		1IN, 2IN	-0.3 V_{CC} V
	Continuous regulator output current		REG_OUT	0 20 mA
T_A	Operating ambient temperature range	-40	125	°C

ELECTRICAL CHARACTERISTICS

 over recommended operating ambient temperature range, $V_{CC} = 10$ V, REG_IN open, $C_L = 1$ nF (unless otherwise noted)

PARAMETER		TEST CONDITIONS		MIN	TYP ⁽¹⁾	MAX	UNIT
INPUTS							
V_{T+}	Positive-going input threshold voltage	$V_{CC} = 5$ V		3.3		4	V
		$V_{CC} = 10$ V		5.8		9	
		$V_{CC} = 14$ V		8.3		13	
V_{T-}	Negative-going input threshold voltage	$V_{CC} = 5$ V		1		1.6	V
		$V_{CC} = 10$ V		1		4.2	
		$V_{CC} = 14$ V		1		6.2	
	Input hysteresis	$V_{CC} = 5$ V				1.6	V
I_I	Input current	Inputs = 0 V or V_{CC}		-1	0.2	1	μ A
C_I	Input capacitance					5 10	pF
OUTPUTS							
V_{OH}	High-level output voltage	$I_O = -1$ mA		9.75		9.9	V
		$I_O = -100$ mA		8		9.1	
V_{OL}	Low-level output voltage	$I_O = 1$ mA			0.18	0.25	V
		$I_O = 100$ mA			1	2	
I_O	Peak output current	$V_{CC} = 10$ V				2	A
REGULATOR							
V_O	Output voltage	$14 \leq \text{REG_IN} \leq 40$ V, $0 \leq I_O \leq 20$ mA		10	11.5	13	V
	Output voltage in dropout	$I_O = 10$ mA, REG_IN = 10 V		9		9.6	V
SUPPLY CURRENT							
I_{CC}	Supply current into V_{CC}	Inputs high or low			0.2	5	μ A
	Supply current into REG_IN	REG_IN = 20 V, REG_OUT open			40	100	μ A

- (1) Typical values are at $T_A = 25^\circ\text{C}$ unless otherwise noted.

SWITCHING CHARACTERISTICS

over recommended operating ambient temperature range, REG_IN open, $C_L = 1$ nF (unless otherwise noted)

PARAMETER		TEST CONDITIONS	MIN	TYP ⁽¹⁾	MAX	UNIT
t_r	Rise time	$V_{CC} = 14$ V		14	25	ns
		$V_{CC} = 10$ V		15	30	
		$V_{CC} = 5$ V		20	35	
t_f	Fall time	$V_{CC} = 14$ V		15	25	ns
		$V_{CC} = 10$ V		15	30	
		$V_{CC} = 5$ V		18	35	
t_{PHL}	Propagation delay time, high-to-low-level output	$V_{CC} = 14$ V		25	40	ns
		$V_{CC} = 10$ V		25	45	
		$V_{CC} = 5$ V		34	50	
t_{PLH}	Propagation delay time low-to-high-level output	$V_{CC} = 14$ V		24	40	ns
		$V_{CC} = 10$ V		26	45	
		$V_{CC} = 5$ V		36	50	

(1) Typical values are at $T_A = 25^\circ\text{C}$ unless otherwise noted.

PARAMETER MEASUREMENT INFORMATION

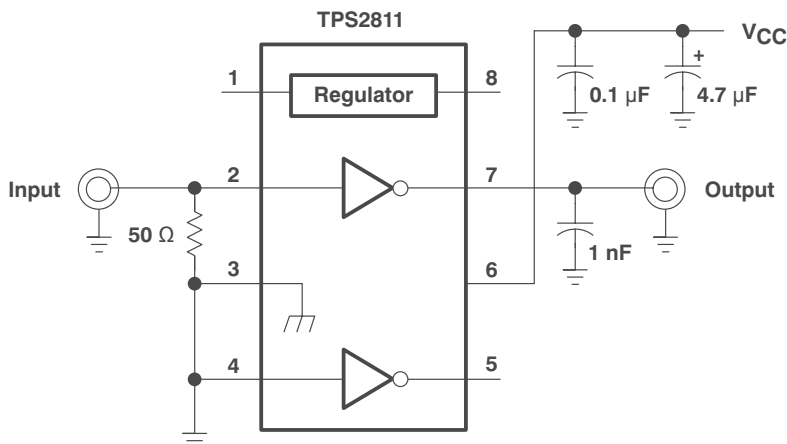

Figure 1. Test Circuit For Measurement of Switching Characteristics

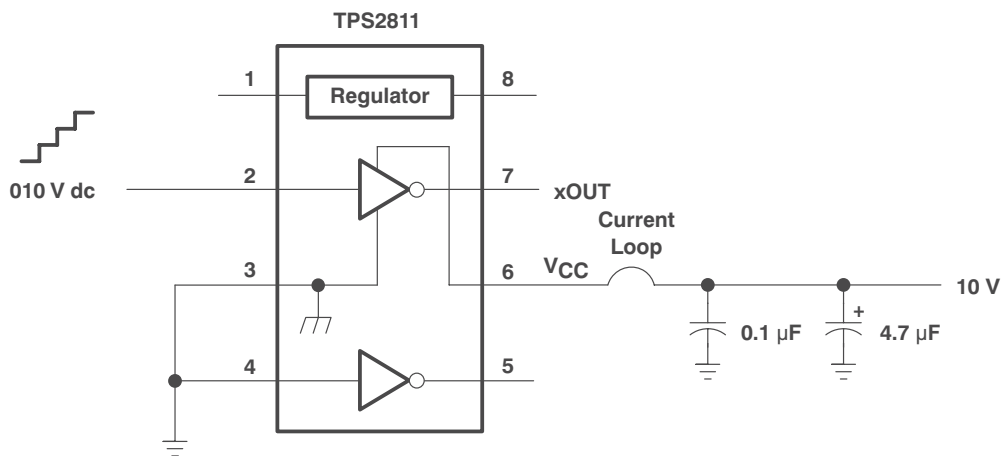

Figure 2. Shoot-Through Current Test Setup

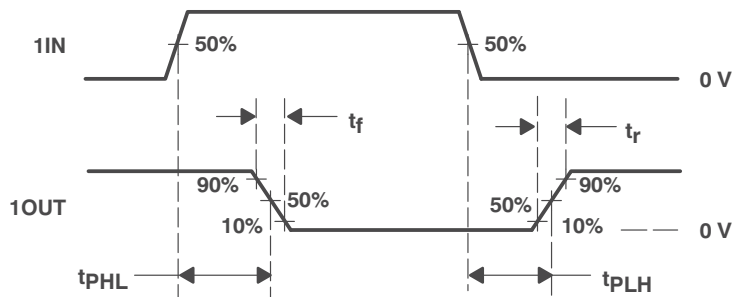

Figure 3. Typical Timing Diagram

TYPICAL CHARACTERISTICS

Table 1. Characteristics Graphs and Application Information

PARAMETER	vs PARAMETER 2		FIGURE
Typical Characteristics			
Rise time	Supply voltage		4
Fall time	Supply voltage		5
Propagation delay time	Supply voltage		6, 7
Supply current	Supply voltage		8
	Load capacitance		9
	Ambient temperature		0
Input threshold voltage	Supply voltage		11
Regulator output voltage	Regulator input voltage		12, 13
Regulator quiescent current	Regulator input voltage		14
Peak source current	Supply voltage		15
Peak sink current	Supply voltage		16
Shoot-through current	Input voltage, high-to-low		17
	Input voltage, low-to-high		18
General Applications			
Switching test circuits and application information			19, 20
Voltage of 1OUT vs 2OUT	Time	Low-to-high	21, 22, 23
		High-to-low	24, 25, 26
Circuit for Measuring Paralleled Switching Characteristics			
Switching test circuits and application information			27
Input voltage vs output voltage	Time	Low-to-high	28, 30
		High-to-low	29, 31
Hex-1 to Hex-4 Application Information			
Driving test circuit and application information			32
Drain-source voltage vs drain current	Time	Hex-1 size	33
		Hex-2 size	36
		Hex-3 size	39
		Hex-4 size	41
		Hex-4 size parallel drive	45
	Time	Hex-1 size	34
		Hex-2 size	37
		Hex-3 size	40
		Hex-4 size	43
		Hex-4 size parallel drive	46
	Time	Hex-1 size	35
		Hex-2 size	38
		Hex-3 size	42
		Hex-4 size	44
		Hex-4 size parallel drive	47
Synchronous Buck Regulator Application			
3.3-V 3-A Synchronous-Rectified Buck Regulator Circuit			48
Q1 drain voltage vs gate voltage at turn-on	Time		49
Q1 drain voltage vs gate voltage at turn-off	Time		50
Q1 drain voltage vs Q2 gate-source voltage	Time		51, 52, 53
Output ripple voltage vs inductor current	Time	3 A	54
		5 A	55

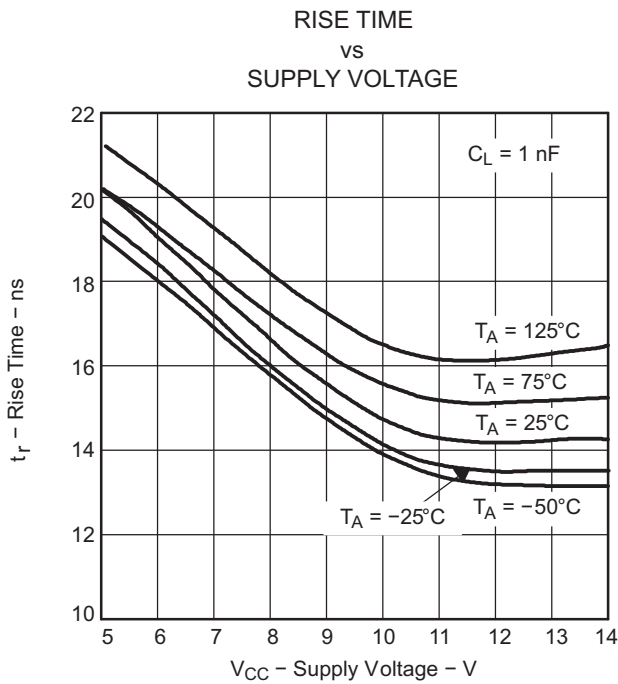

Figure 4.

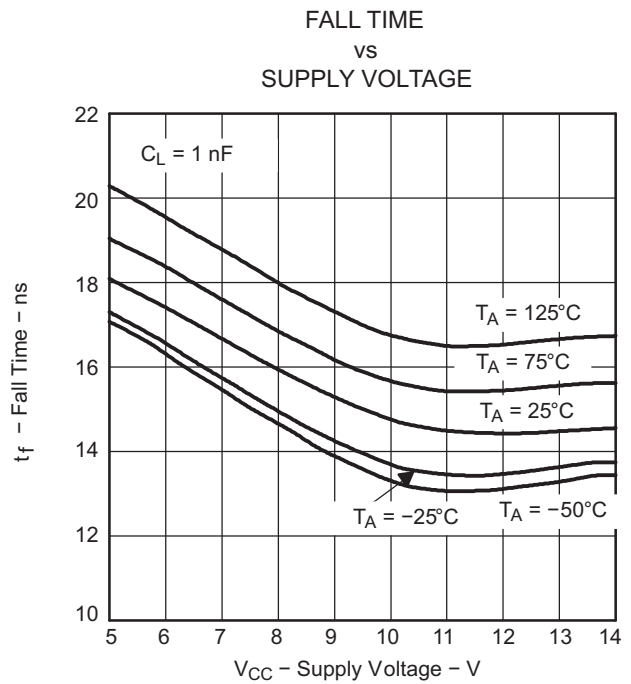

Figure 5.

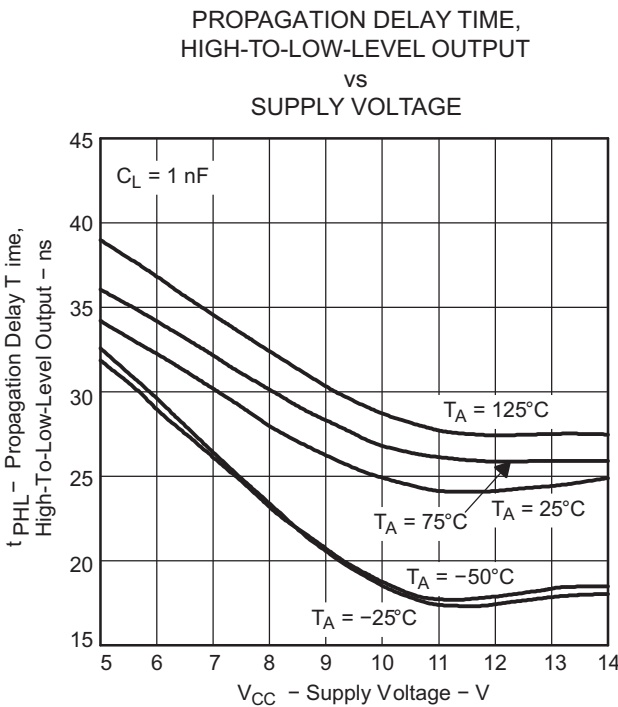

Figure 6.

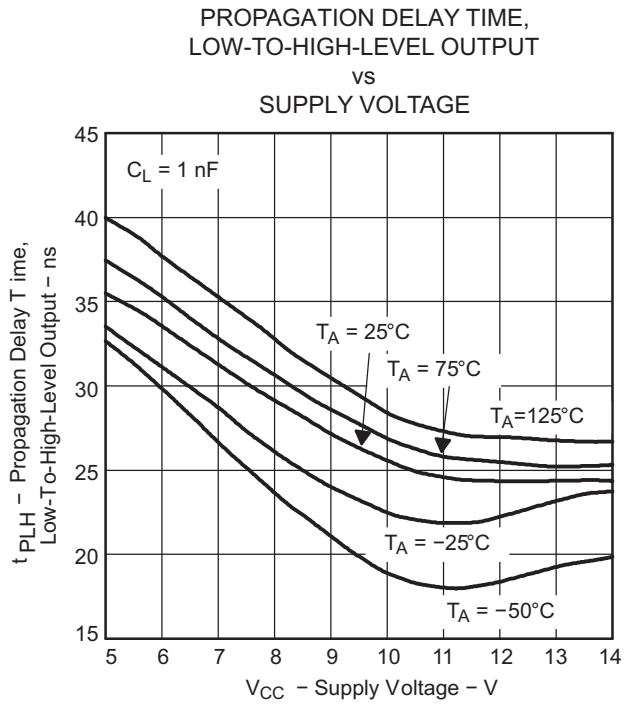

Figure 7.

SUPPLY CURRENT
vs
SUPPLY VOLTAGE

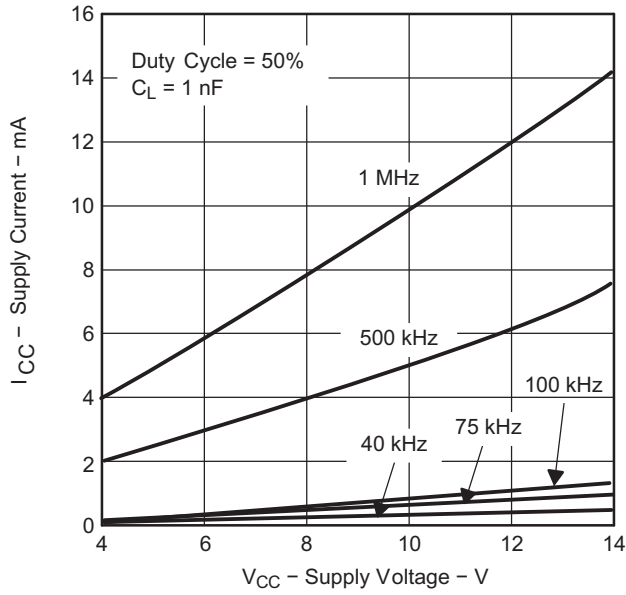

Figure 8.

SUPPLY CURRENT
vs
LOAD CAPACITANCE

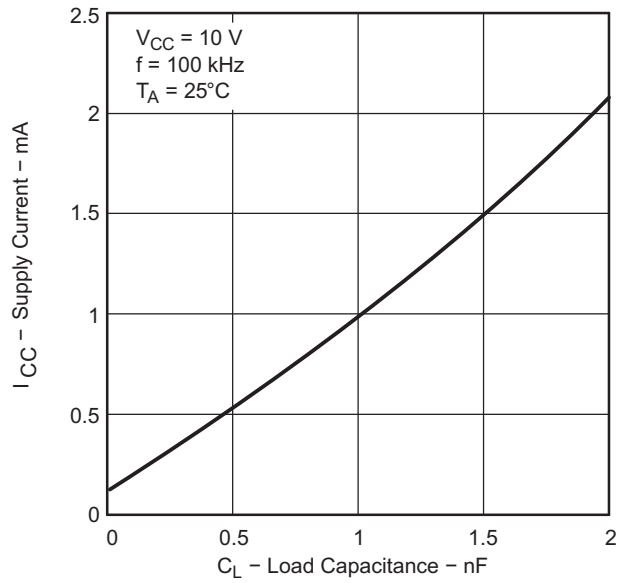

Figure 9.

SUPPLY CURRENT
vs
AMBIENT TEMPERATURE

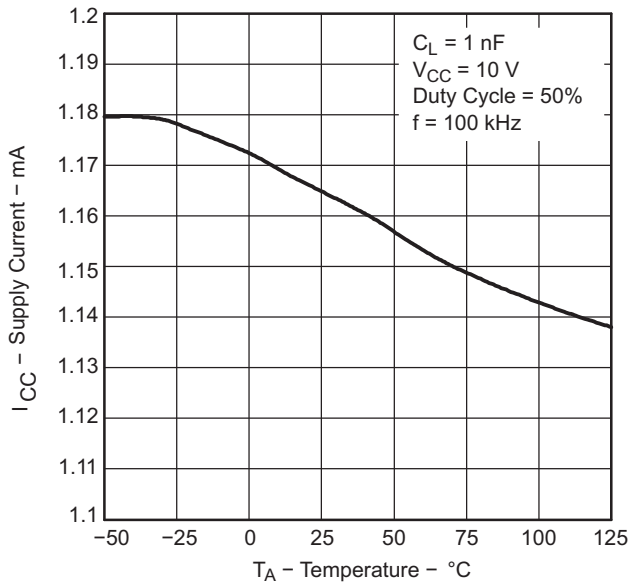

Figure 10.

INPUT THRESHOLD VOLTAGE
vs
SUPPLY VOLTAGE

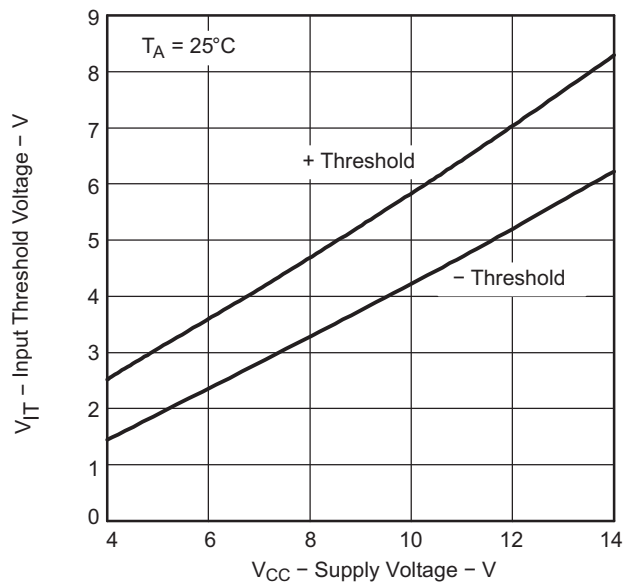

Figure 11.

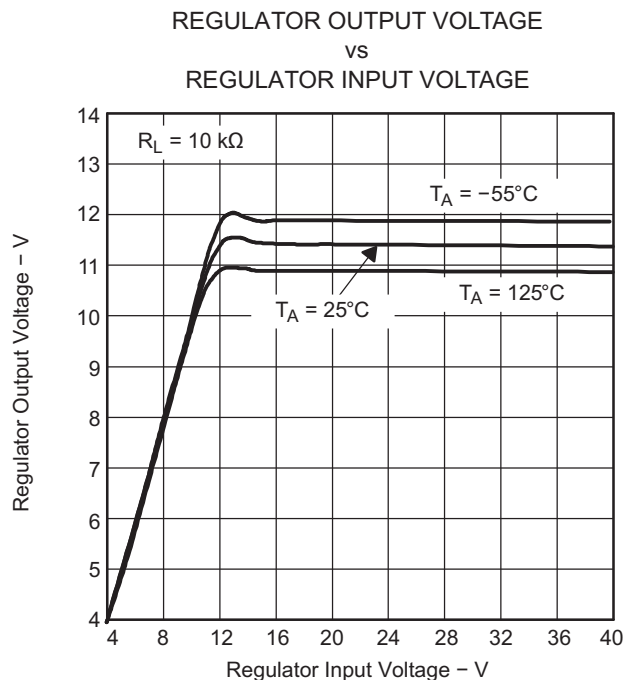

Figure 12.

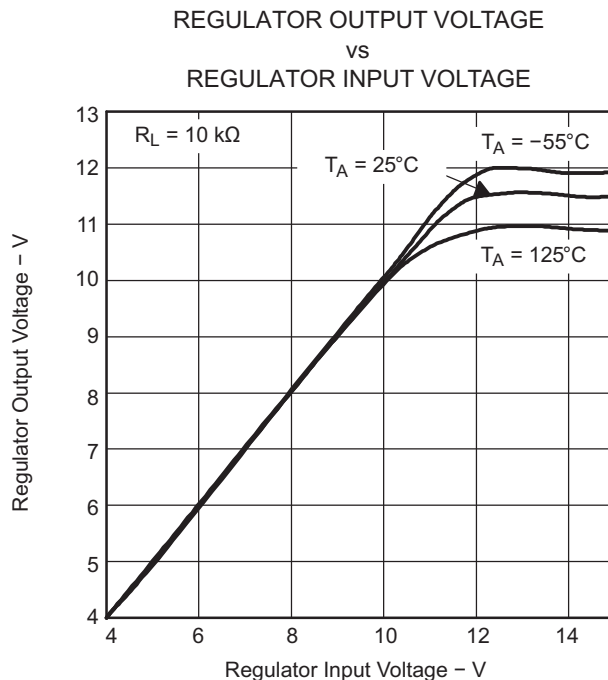

Figure 13.

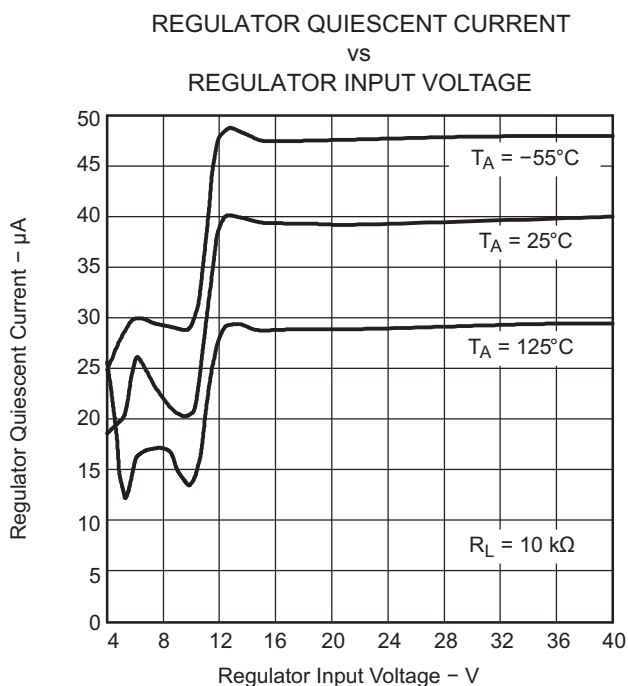

Figure 14.

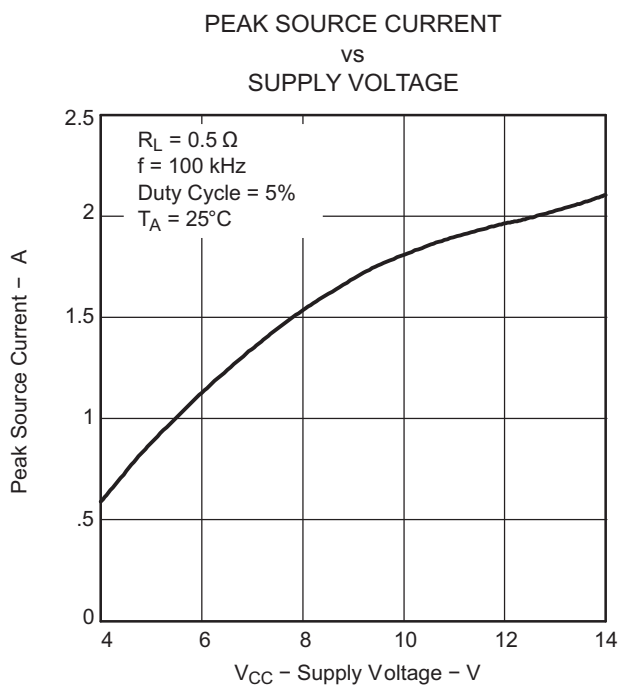

Figure 15.

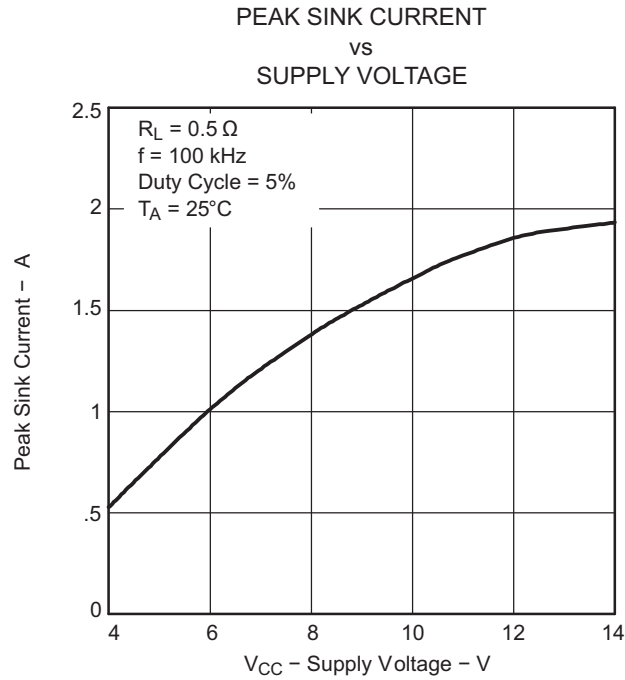

Figure 16.

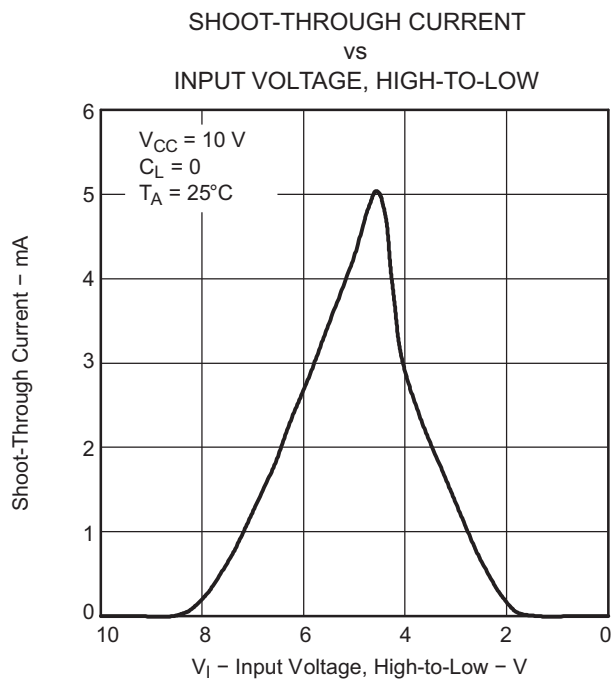

Figure 17.

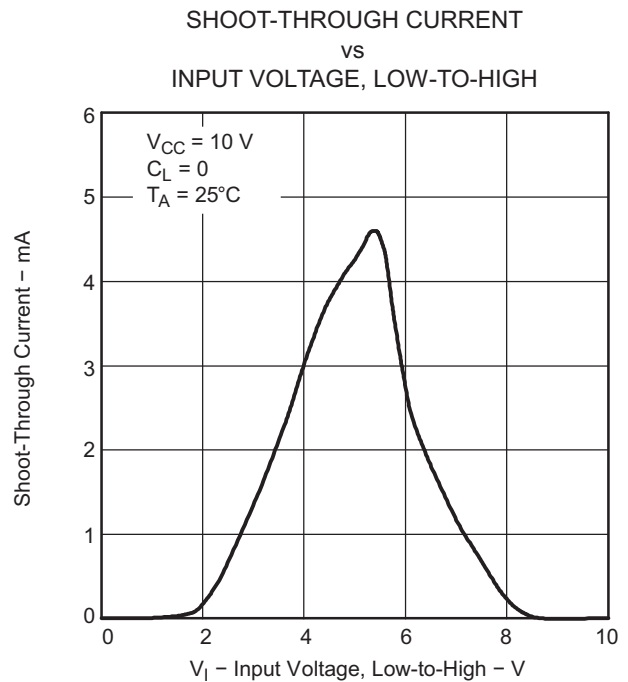

Figure 18.

APPLICATION INFORMATION

The TPS2811 circuits each contain one regulator and two MOSFET drivers. The regulator can be used to limit V_{CC} to between 10 V and 13 V for a range of input voltages from 14 V to 40 V, while providing up to 20 mA of dc drive. The TPS2811 has inverting drivers. These MOSFET drivers are capable of supplying up to 2.1 A or sinking up to 1.9 A (see Figures 15 and 16) of instantaneous current to n-channel or p-channel MOSFETs. The TPS2811 MOSFET drivers have very fast switching times combined with very short propagation delays. These features enhance the operation of today's high-frequency circuits.

The CMOS input circuit has a positive threshold of approximately $2/3$ of V_{CC} , with a negative threshold of $1/3$ of V_{CC} , and a very high input impedance in the range of 109Ω . Noise immunity is also very high because of the Schmitt-trigger switching. In addition, the design is such that the normal shoot-through current in CMOS (when the input is biased halfway between V_{CC} and ground) is limited to less than 6 mA. The limited shoot-through is evident in the graphs in Figures 17 and 18. The input stage shown in the functional block diagram better illustrates the way the front end works. The circuitry of the device is such that regardless of the rise and/or fall time of the input signal, the output signal will always have a fast transition speed; this basically isolates the waveforms at the input from the output. Therefore, the specified switching times are not affected by the slopes of the input waveforms.

The basic driver portion of the circuits operate over a supply voltage range of 4 V to 14 V with a maximum bias current of 5 μ A. Each driver consists of a CMOS input and a buffered output with a 2-A instantaneous drive capability. They have propagation delays of less than 30 ns and rise and fall times of less than 20 ns each. Placing a 0.1- μ F ceramic capacitor between V_{CC} and ground is recommended; this will supply the instantaneous current needed by the fast switching and high current surges of the driver when it is driving a MOSFET.

The output circuit is also shown in the functional block diagram. This driver uses a unique combination of a bipolar transistor in parallel with a MOSFET for the ability to swing from V_{CC} to ground while providing 2 A of instantaneous driver current. This unique parallel combination of bipolar and MOSFET output transistors provides the drive required at V_{CC} and ground to guarantee turn-off of even low-threshold MOSFETs. Typical bipolar-only output devices don't easily approach V_{CC} or ground.

The regulator included in the TPS2811 has an input voltage range of 14 V to 40 V. It produces an output voltage of 10 V to 13 V and is capable of supplying from 0 to 20 mA of output current. In grounded source applications, this extends the overall circuit operation to 40 V by clamping the driver supply voltage (V_{CC}) to a safe level for both the driver and the MOSFET gate. The bias current for full operation is a maximum of 150 μ A. A 0.1- μ F capacitor connected between the regulator output and ground is required to ensure stability. For transient response, an additional 4.7- μ F electrolytic capacitor on the output and a 0.1- μ F ceramic capacitor on the input will optimize the performance of this circuit. When the regulator is not in use, it can be left open at both the input and the output, or the input can be shorted to the output and tied to either the V_{CC} or the ground pin of the chip.

Matching and Paralleling Connections

Figure 19 and Figure 20 show the delays for the rise and fall time of each channel. As can be seen on a 5-ns scale, there is very little difference between the two channels at no load. Figures 23 and 24 show the difference between the two channels for a 1-nF load on each output. There is a slight delay on the rising edge, but little or no delay on the falling edge. As an example of extreme overload, Figures 25 and 26 show the difference between the two channels, or two drivers in the package, each driving a 10-nF load. As would be expected, the rise and fall times are significantly slowed down. Figures 28 and 29 show the effect of paralleling the two channels and driving a 1-nF load. A noticeable improvement is evident in the rise and fall times of the output waveforms. Finally, Figures 30 and 31 show the two drivers being paralleled to drive the 10-nF load and as could be expected the waveforms are improved. In summary, the paralleling of the two drivers in a package enhances the capability of the drivers to handle a larger load. Because of manufacturing tolerances, it is not recommended to parallel drivers that are not in the same package.

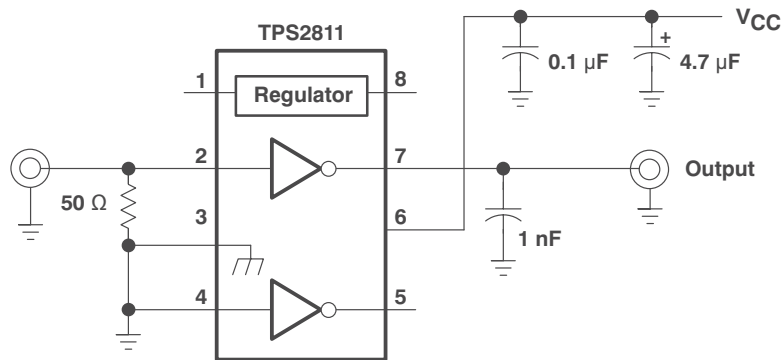
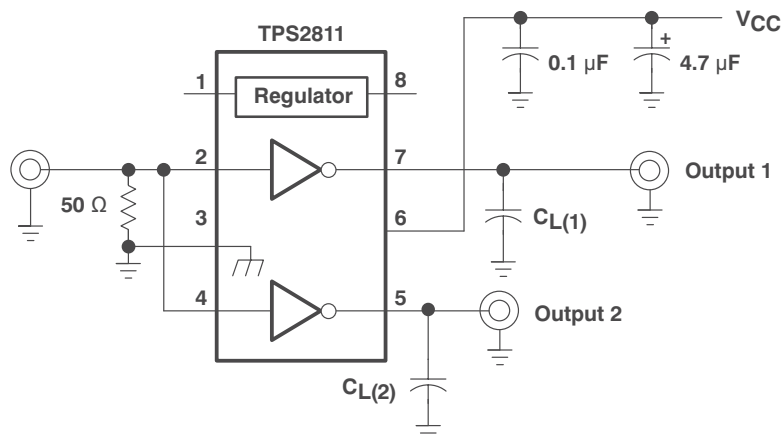
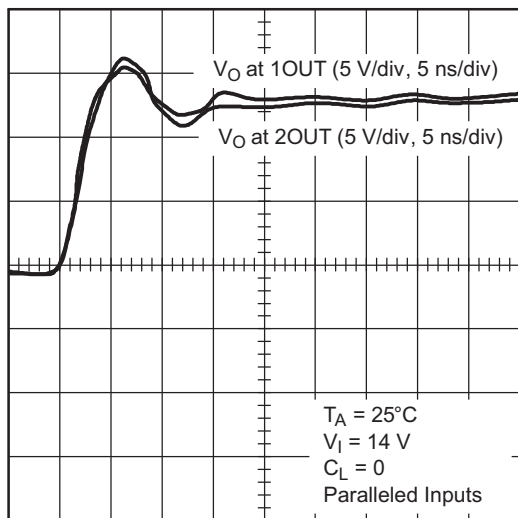

Figure 19. Test Circuit for Measuring Switching Characteristics



A. Input rise and fall times should be ≤ 10 ns for accurate measurement of ac parameters.

Figure 20. Test Circuit for Measuring Switching Characteristics With the Inputs Connected in Parallel



t - Time

Figure 21. Voltage of 1OUT vs Voltage at 2OUT, Low-to-High Output Delay

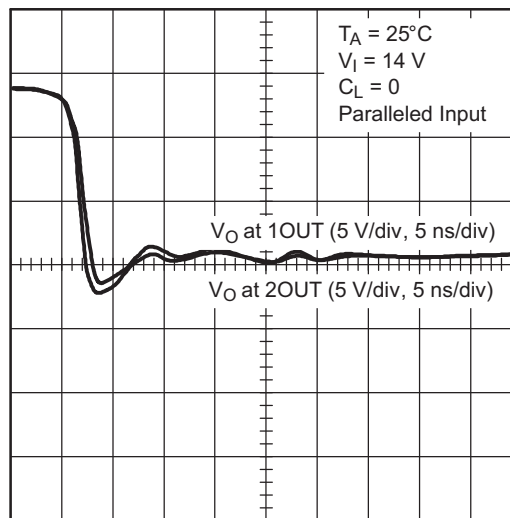

t - Time

Figure 22. Voltage at 1OUT vs Voltage at 2OUT, High-to-Low Output Delay

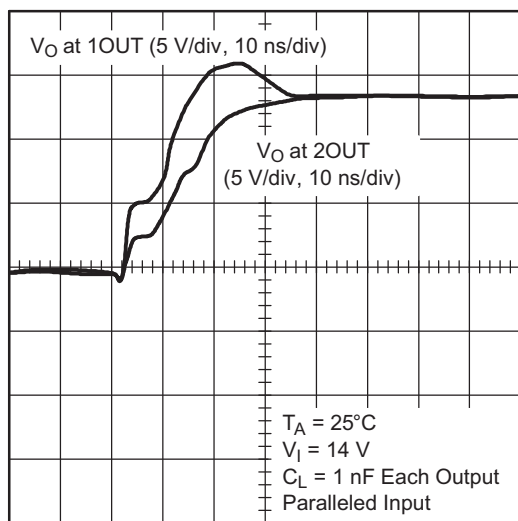

t - Time

Figure 23. Voltage at 1OUT vs Voltage at 2OUT, Low-to-High Output Delay

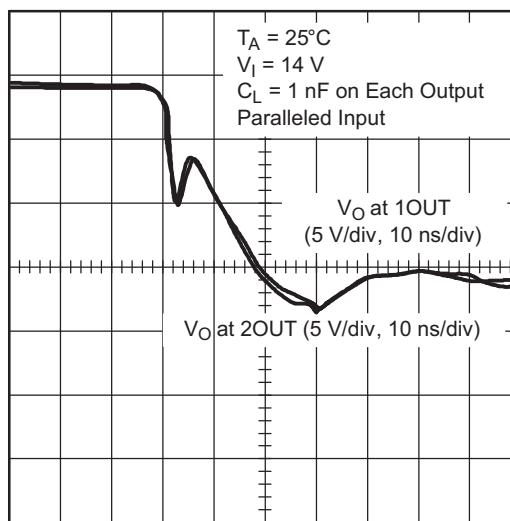

t - Time

Figure 24. Voltage at 1OUT vs Voltage at 2OUT, High-to-Low Output Delay

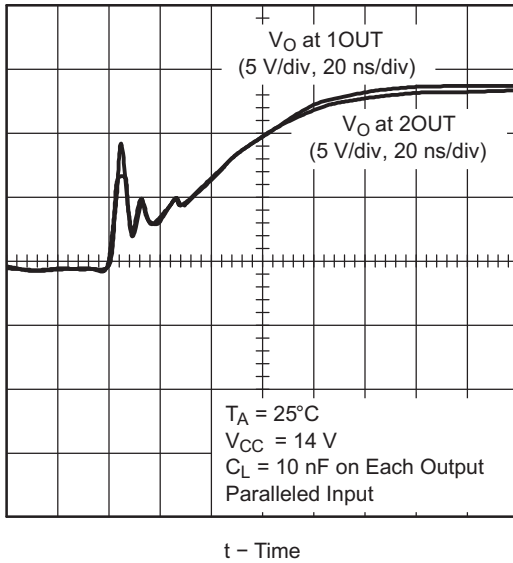

Figure 25. Voltage at 1OUT vs Voltage at 2OUT, Low-to-High Output Delay

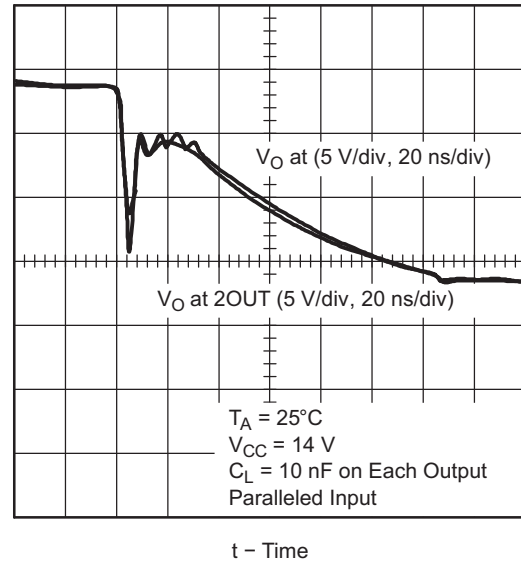

Figure 26. Voltage at 1OUT vs Voltage at 2OUT, High-to-Low Output Delay

A. Input rise and fall times should be ≤ 10 ns for accurate measurement of ac parameters.

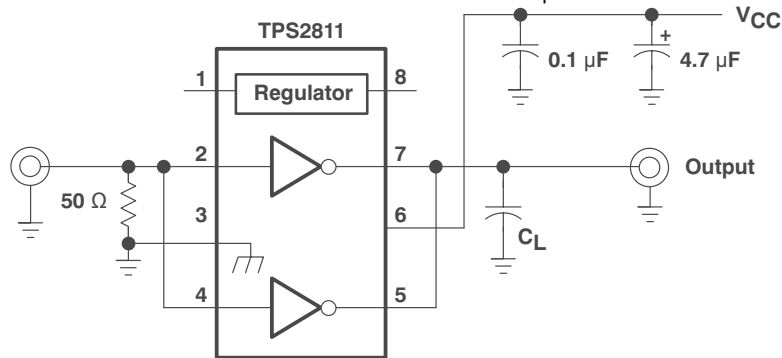
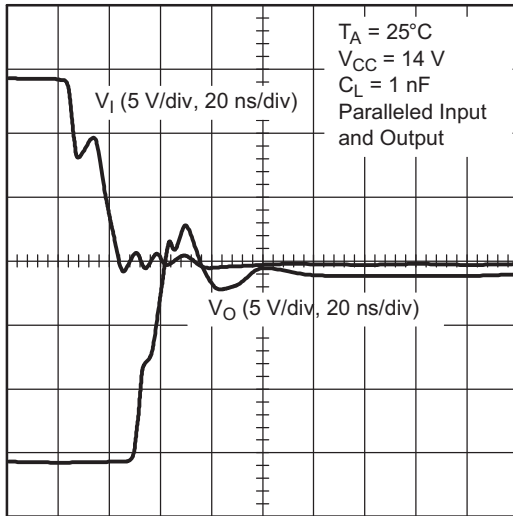
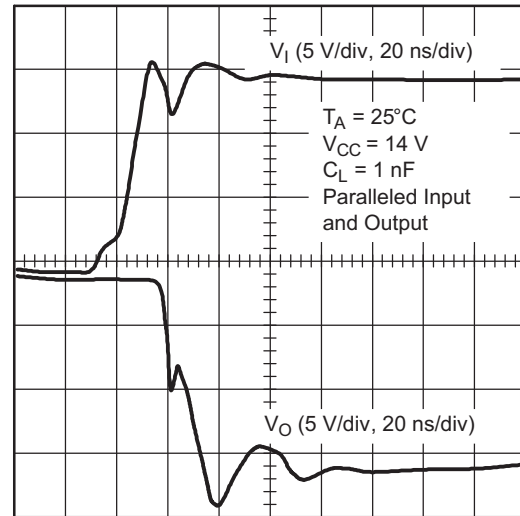

Figure 27. Test Circuit for Measuring Paralleled Switching Characteristics



t - Time

Figure 28. Input Voltage vs Output Voltage, Low-to-High Propagation Delay of Paralleled Drivers



t - Time

Figure 29. Input Voltage vs Output Voltage, High-to-Low Propagation Delay of Paralleled Drivers

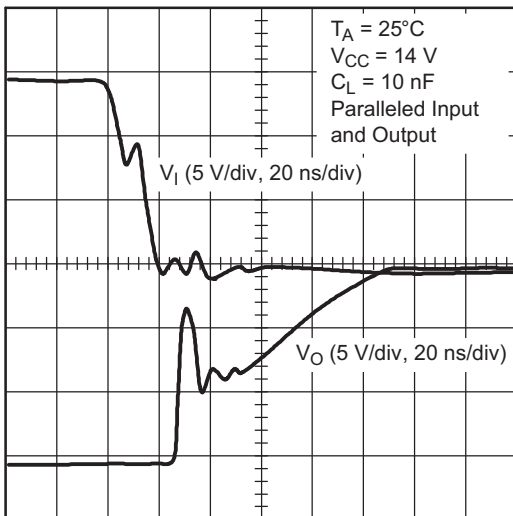

t - Time

Figure 30. Input Voltage vs Output Voltage, Low-to-High Propagation Delay of Paralleled Drivers

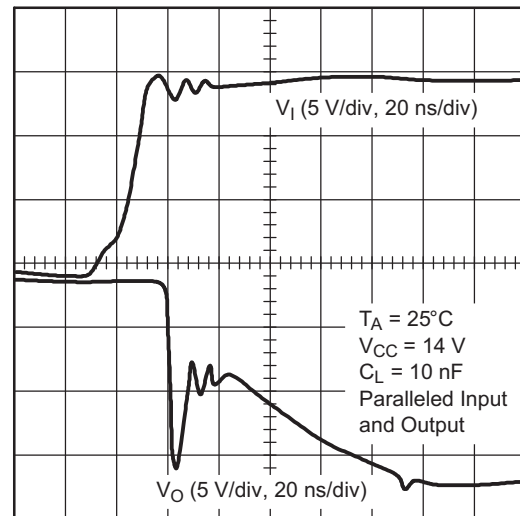

t - Time

Figure 31. Input Voltage vs Output Voltage, High-to-Low Propagation Delay of Paralleled Drivers

Figures 33 through 47 illustrate the performance of the TPS2811 driving MOSFETs with clamped inductive loads, similar to what is encountered in discontinuous-mode flyback converters. The MOSFETs that were tested range in size from Hex-1 to Hex-4, although the TPS28xx family is only recommended for Hex-3 or below.

The test circuit is shown in Figure 32. The layout rules observed in building the test circuit also apply to real applications. Decoupling capacitor C1 is a 0.1- μF ceramic device, connected between V_{CC} and GND of the TPS2811, with short lead lengths. The connection between the driver output and the MOSFET gate, and between GND and the MOSFET source, are as short as possible to minimize inductance. Ideally, GND of the driver is connected directly to the MOSFET source. The tests were conducted with the pulse generator frequency set very low to eliminate the need for heat sinking, and the duty cycle was set to turn off the MOSFET when the drain current reached 50% of its rated value. The input voltage was adjusted to clamp the drain voltage at 80% of its rating.

As shown, the driver is capable of driving each of the Hex-1 through Hex-3 MOSFETs to switch in 20 ns or less. Even the Hex-4 is turned on in less than 20 ns. Figures 45, 46 and 47 show that paralleling the two drivers in a package enhances the gate waveforms and improves the switching speed of the MOSFET. Generally, one driver is capable of driving up to a Hex-4 size. The TPS2811 family is even capable of driving large MOSFETs that have a low gate charge.

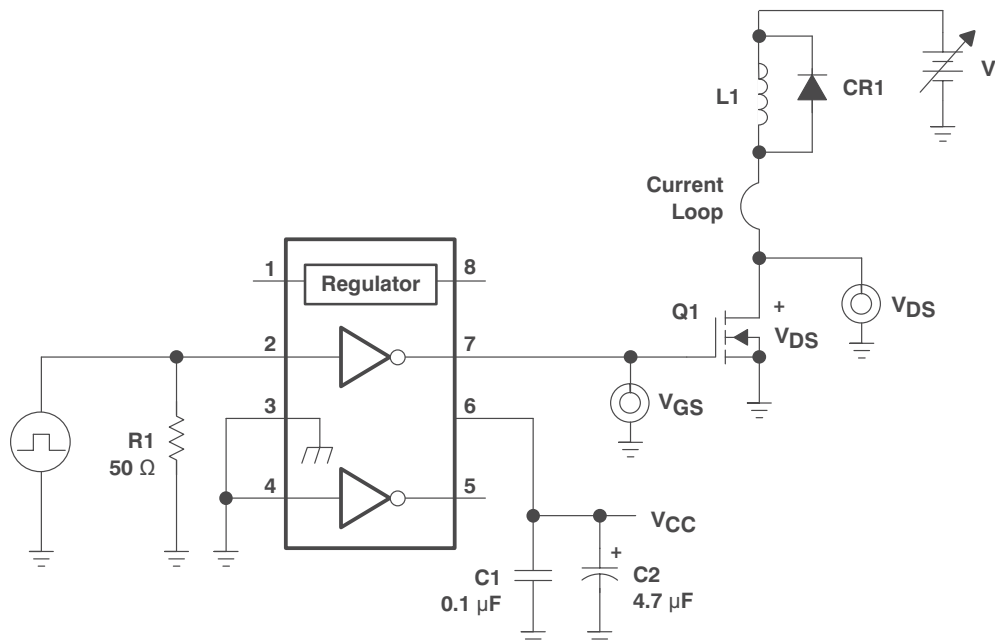
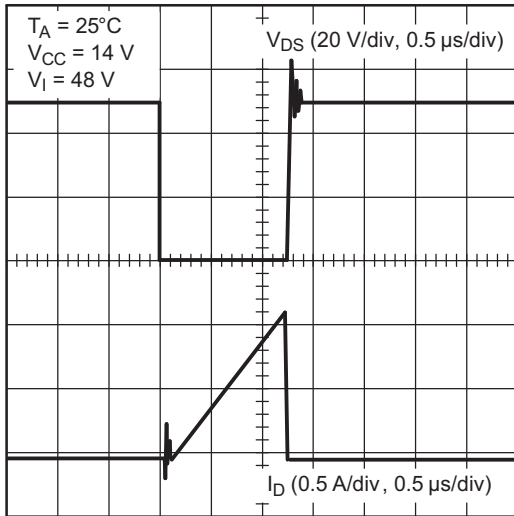
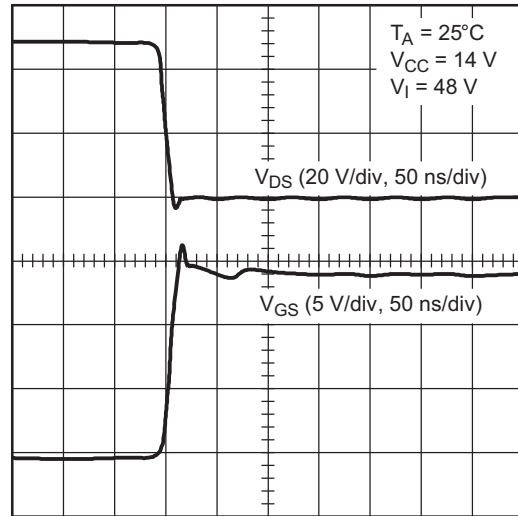

Figure 32. TPS2811 Driving Hex-1 through Hex-4 Devices



t - Time

Figure 33. Drain-Source Voltage vs Drain Current, TPS2811 Driving an IRFD014 (Hex-1 Size)



t - Time

Figure 34. Drain-Source Voltage vs Gate-Source Voltage, at Turn-on, TPS2811 Driving an IRFD014 (Hex-1 Size)

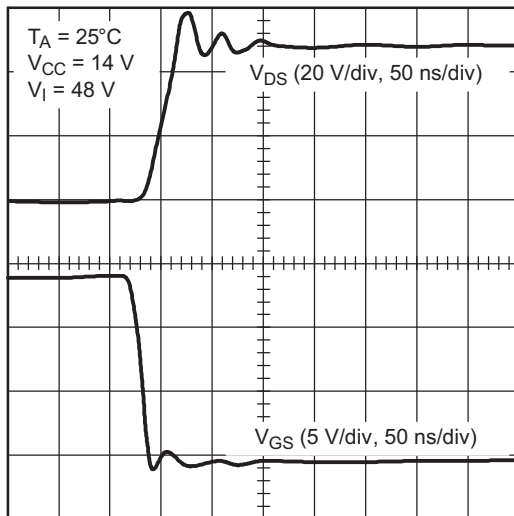

t - Time

Figure 35. Drain-Source Voltage vs Gate-Source Voltage, at Turn-off, TPS2811 Driving an IRFD014 (Hex-1 Size)

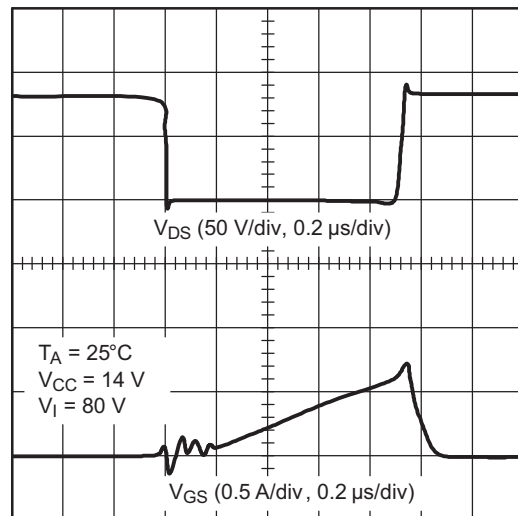

t - Time

Figure 36. Drain-Source Voltage vs Drain Current, TPS2811 Driving an IRFD120 (Hex-2 Size)

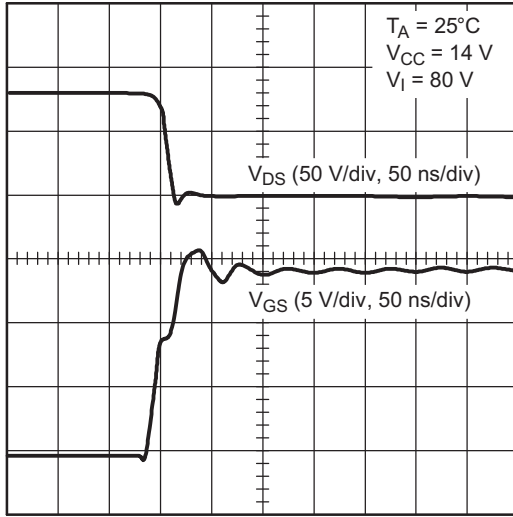

t - Time

Figure 37. Drain-Source Voltage vs Gate-Source Voltage, at Turn-on, TPS2811 Driving an IRFD120 (Hex-2 Size)

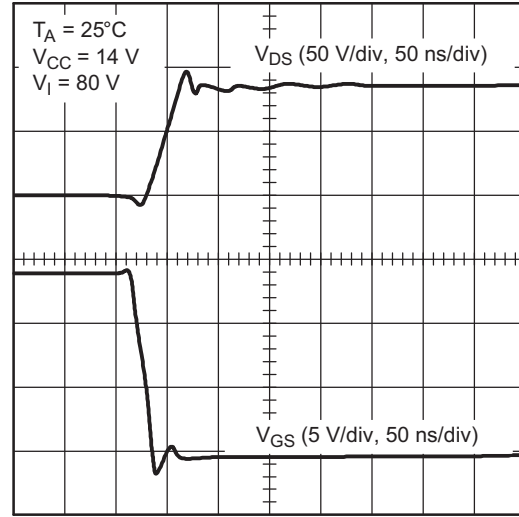

t - Time

Figure 38. Drain-Source Voltage vs Gate-Source Voltage, at Turn-off, TPS2811 Driving an IRFD120 (Hex-2 Size)

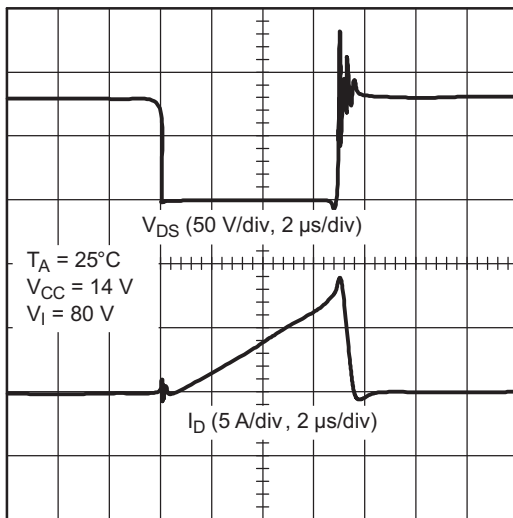

t - Time

Figure 39. Drain-Source Voltage vs Drain Current, TPS2811 Driving an IRF530 (Hex-3 Size)

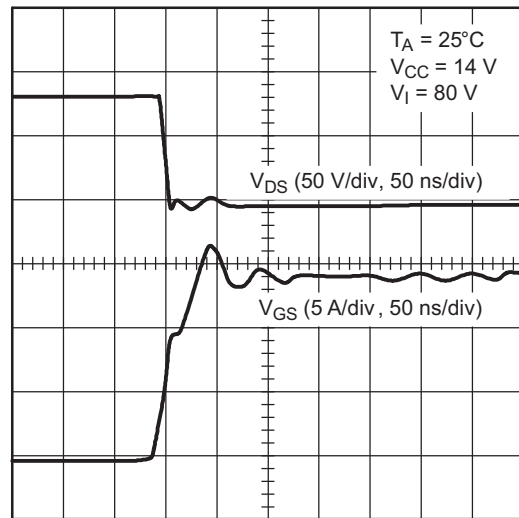

t - Time

Figure 40. Drain-Source Voltage vs Gate-Source Voltage, at Turn-on, TPS2811 Driving an IRF530 (Hex-3 Size)

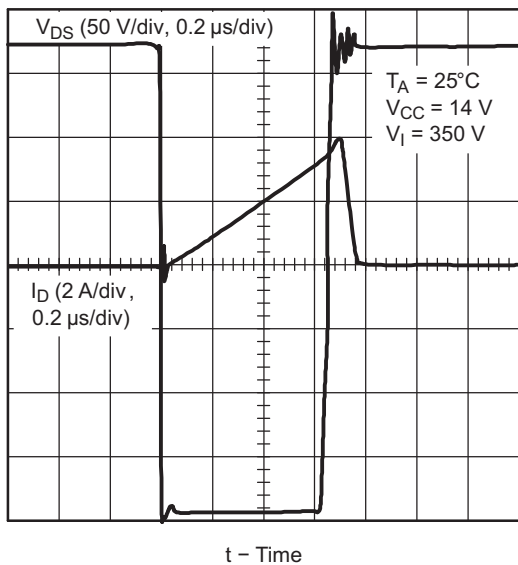

Figure 41. Drain-Source Voltage vs Drain Current, One Driver, TPS2811 Driving an IRF840 (Hex-4 Size)

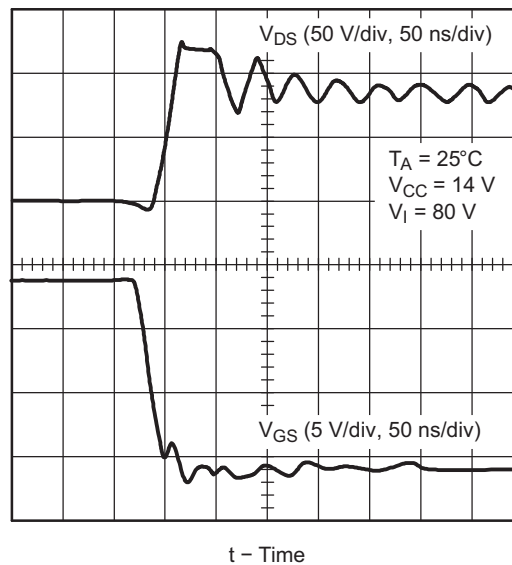

Figure 42. Drain-Source Voltage vs Gate-Source Voltage, at Turn-off, TPS2811 Driving an IRF530 (Hex-3 Size)

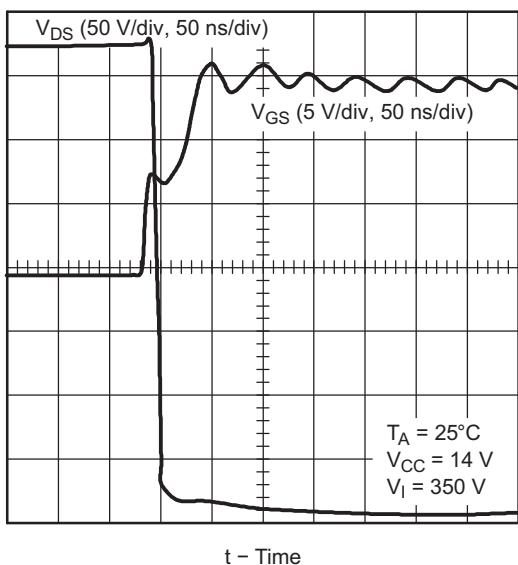

Figure 43. Drain-Source Voltage vs Gate-Source Voltage, at Turn-on, One Driver, TPS2811 Driving an IRF840 (Hex-4 Size)

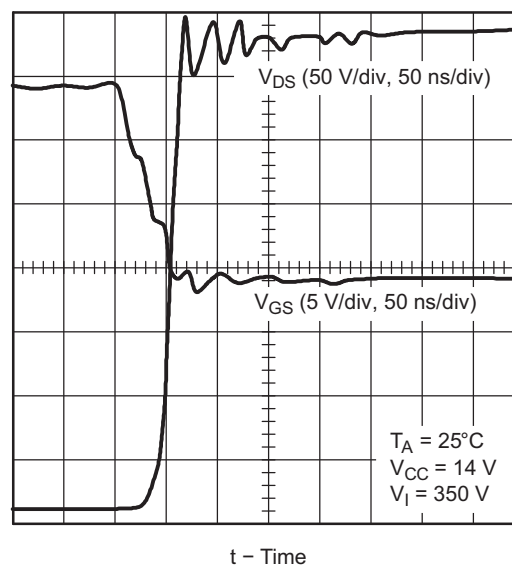

Figure 44. Drain-Source Voltage vs Gate-Source Voltage, at Turn-off, One Driver, TPS2811 Driving an IRF840 (Hex-4 Size)

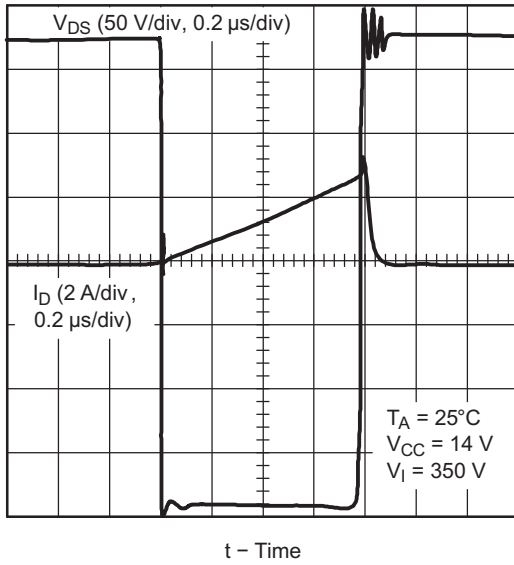

Figure 45. Drain-Source Voltage vs Drain Current, Parallel Drivers, TPS2811 Driving an IRF840 (Hex-4 Size)

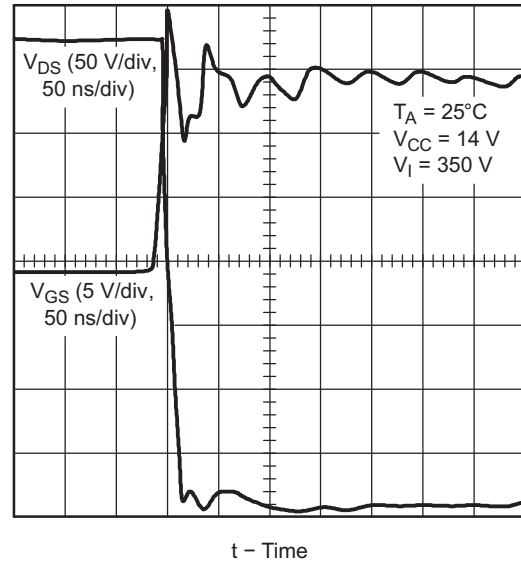

Figure 46. Drain-Source Voltage vs Gate-Source Voltage, at Turn-on, Parallel Drivers, TPS2811 Driving an IRF840 (Hex-4 Size)

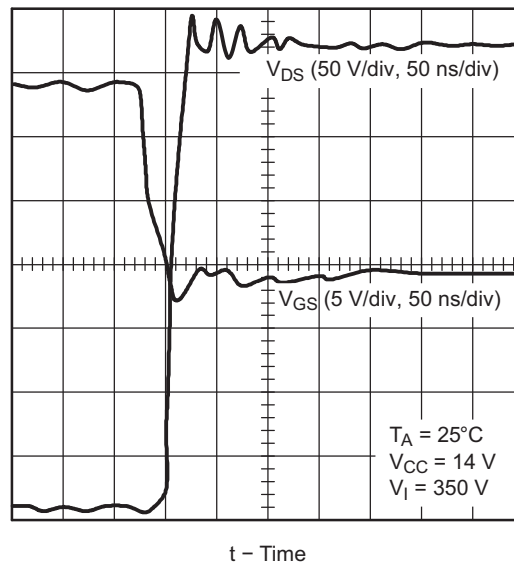
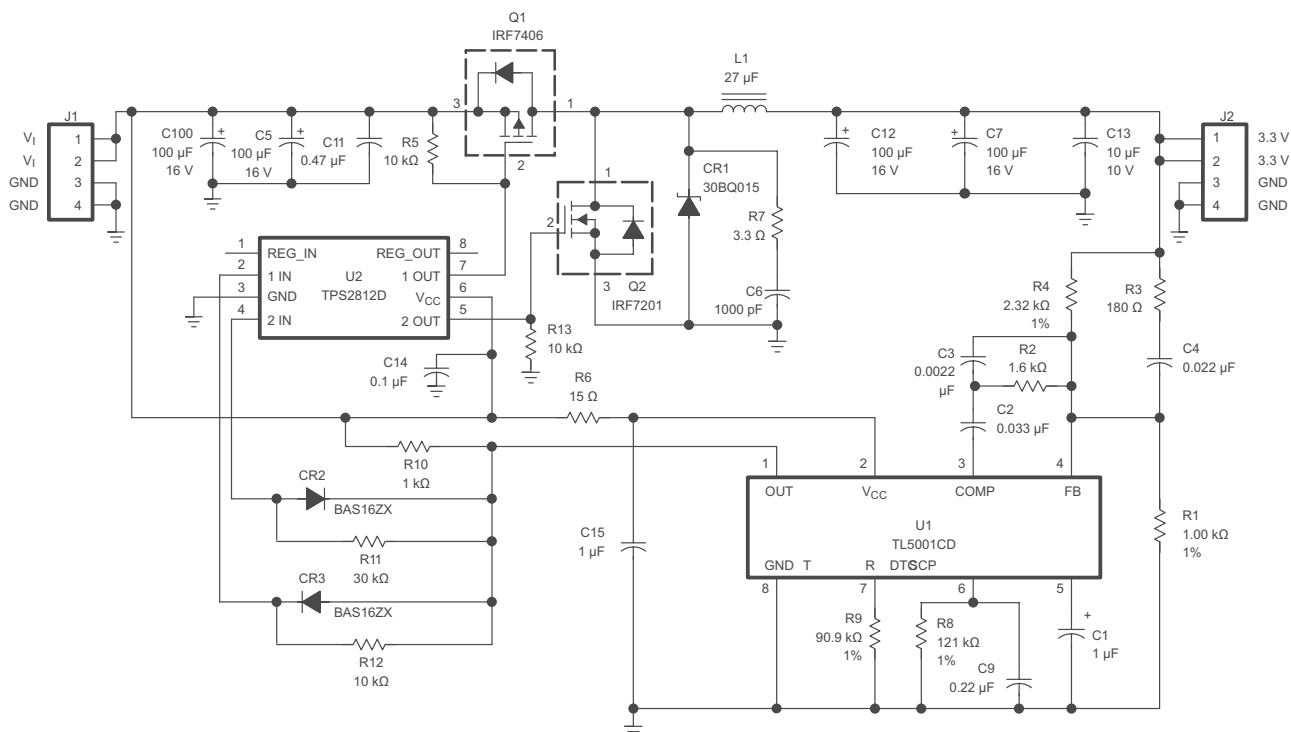

Figure 47. Drain-Source Voltage vs Gate-Source Voltage, at Turn-off, Parallel Drivers, TPS2811 Driving an IRF840 (Hex-4 Size)

Synchronous Buck Regulator

Figure 48 is the schematic for a 100-kHz synchronous-rectified buck converter implemented with a TL5001 pulse-width-modulation (PWM) controller and a TPS2812 driver. The bill of materials is provided in Table 1. The converter operates over an input range from 5.5 V to 12 V and has a 3.3-V output capable of supplying 3 A continuously and 5 A during load surges. The converter achieves an efficiency of 90.6% at 3 A and 87.6% at 5 A. Figures 49 and 50 show the power switch switching performance. The output ripple voltage waveforms are documented in Figures 54 and 55.

The TPS2812 drives both the power switch, Q2, and the synchronous rectifier, Q1. Large shoot-through currents, caused by power switch and synchronous rectifier remaining on simultaneously during the transitions, are prevented by small delays built into the drive signals, using CR2, CR3, R11, R12, and the input capacitance of the TPS2812. These delays allow the power switch to turn off before the synchronous rectifier turns on and vice versa. Figure 51 shows the delay between the drain of Q2 and the gate of Q1; expanded views are provided in Figures 52 and 53.



NOTE: If the parasitics of the external circuit cause the voltage to violate the Absolute Maximum Rating for the Output pins, Schottky diodes should be added from ground to output and from output to V_{CC}.

Figure 48. 3.3-V 3-A Synchronous-Rectified Buck Regulator Circuit

Table 2. Bill of Materials, 3.3-V, 3-A Synchronous-Rectified Buck Converter⁽¹⁾

REFERENCE	DESCRIPTION	VENDOR	
U1	TL5001CD, PWM	Texas Instruments	972-644-5580
U2	TPS2812D, N.I. MOSFET Driver	Texas Instruments	972-644-5580
CR1	3 A, 15 V, Schottky, 30BQ015	International Rectifier	310-322-3331
CR2,CR3	Signal Diode, BAS16ZX	Zetex	516-543-7100
C1	1 μ F, 16 V, Tantalum		
C2	0.033 μ F, 50 V		
C3	0.0022 μ F, 50 V		
C4	0.022 μ F, 50 V		
C5,C7,C10,C12	100 μ F, 16 V, Tantalum, TPSE107M016R0100	AVX	800-448-9411
C6	1000 pF, 50 V		
C9	0.22 μ F, 50 V		
C11	0.47 μ F, 50 V, Z5U		
C13	10 μ F, 10 V, Ceramic, CC1210CY5V106Z	TDK	708-803-6100
C14	0.1 μ F, 50 V		
C15	1.0 μ F, 50 V		
J1,J2	4-Pin Header	Nova Magnetics, Inc.	972-272-8287
L1	27 μ H, 3 A/5 A, SML5040	International Rectifier	310-322-3331
Q1	IRF7406, P-FET	International Rectifier	310-322-3331
Q2	IRF7201, N-FET		
R1	1.00 k Ω , 1%		
R2	1.6 k Ω		
R3	180 Ω		
R4	2.32 k Ω , 1 %		
R5,R12,R13	10 k Ω		
R6	15 Ω		
R7	3.3 Ω		
R8	121 k Ω , 1%		
R9	90.9 k Ω , 1%		
R10	1 k Ω		
R11	30 k Ω		

(1) Unless otherwise specified, capacitors are X7R ceramics, and resistors are 5%, 1/10 W.

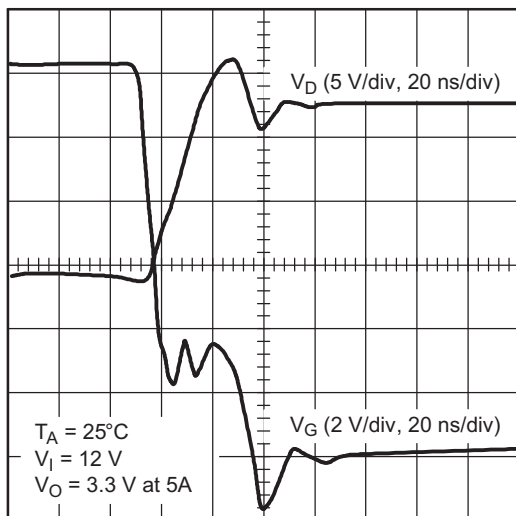

t - Time

Figure 49. Q1 Drain Voltage vs Gate Voltage, at Switch Turn-on

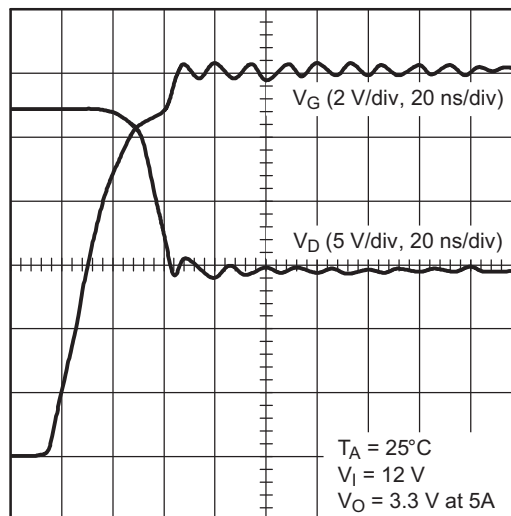

t - Time

Figure 50. Q1 Drain Voltage vs Gate Voltage, at Switch Turn-off

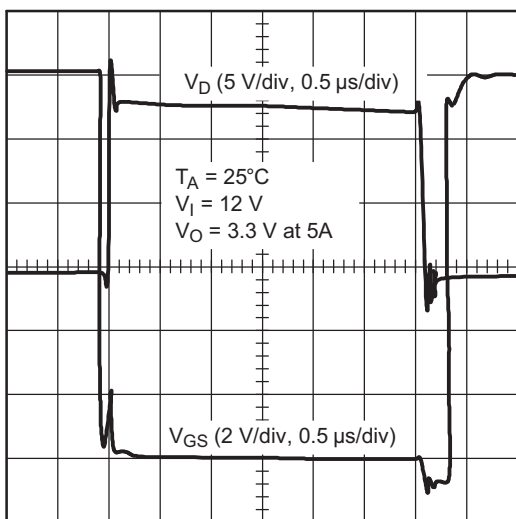

t - Time

Figure 51. Q1 Drain Voltage vs Q2 Gate-Source Voltage

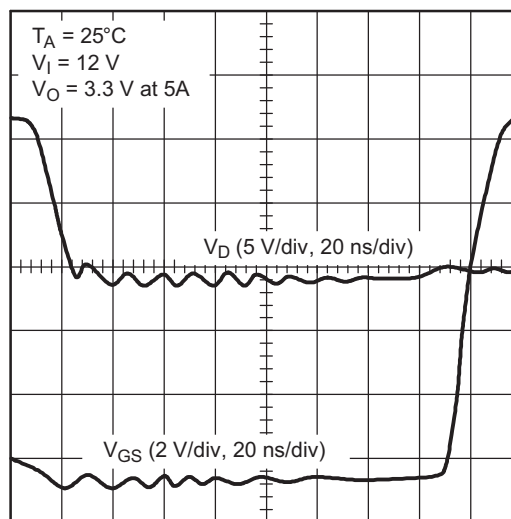

t - Time

Figure 52. Q1 Drain Voltage vs Q2 Gate-Source Voltage

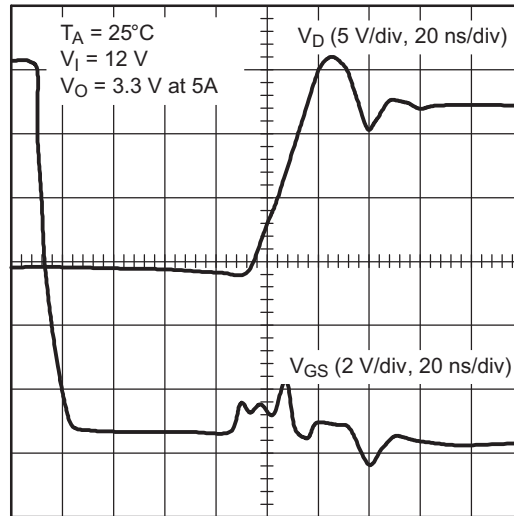

t – Time

Figure 53. Q1 Drain Voltage vs Q2 Gate-Source Voltage

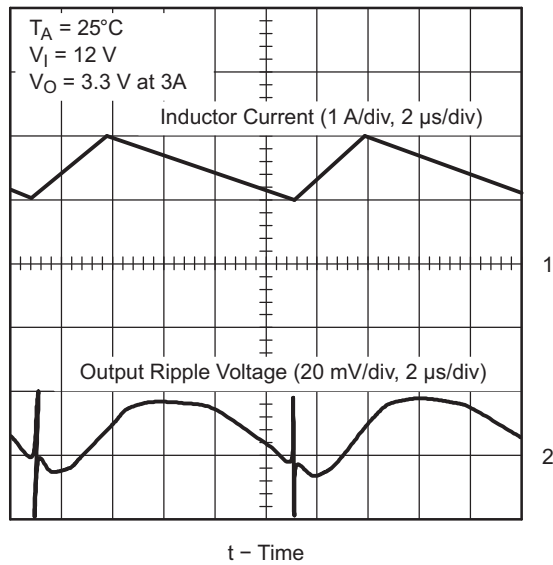

t – Time

Figure 54. Output Ripple Voltage vs Inductor Current, at 3 A

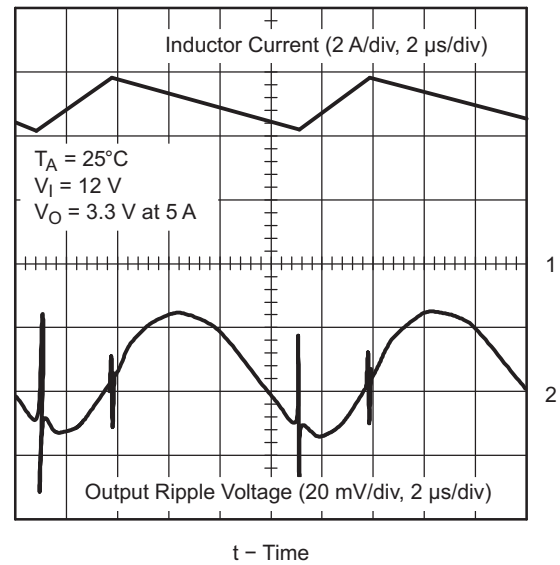

t – Time

Figure 55. Output Ripple Voltage vs Inductor Current, at 5 A

PACKAGING INFORMATION

Orderable Device	Status (1)	Package Type	Package Drawing	Pins	Package Qty	Eco Plan (2)	Lead/Ball Finish	MSL Peak Temp (3)	Op Temp (°C)	Top-Side Markings (4)	Samples
TPS2811QPWRQ1	ACTIVE	TSSOP	PW	8	2000	Green (RoHS & no Sb/Br)	CU NIPDAU	Level-3-260C-168 HR	-40 to 125	2811Q	Samples

(1) The marketing status values are defined as follows:

ACTIVE: Product device recommended for new designs.

LIFEBUY: TI has announced that the device will be discontinued, and a lifetime-buy period is in effect.

NRND: Not recommended for new designs. Device is in production to support existing customers, but TI does not recommend using this part in a new design.

PREVIEW: Device has been announced but is not in production. Samples may or may not be available.

OBSOLETE: TI has discontinued the production of the device.

(2) Eco Plan - The planned eco-friendly classification: Pb-Free (RoHS), Pb-Free (RoHS Exempt), or Green (RoHS & no Sb/Br) - please check <http://www.ti.com/productcontent> for the latest availability information and additional product content details.

TBD: The Pb-Free/Green conversion plan has not been defined.

Pb-Free (RoHS): TI's terms "Lead-Free" or "Pb-Free" mean semiconductor products that are compatible with the current RoHS requirements for all 6 substances, including the requirement that lead not exceed 0.1% by weight in homogeneous materials. Where designed to be soldered at high temperatures, TI Pb-Free products are suitable for use in specified lead-free processes.

Pb-Free (RoHS Exempt): This component has a RoHS exemption for either 1) lead-based flip-chip solder bumps used between the die and package, or 2) lead-based die adhesive used between the die and leadframe. The component is otherwise considered Pb-Free (RoHS compatible) as defined above.

Green (RoHS & no Sb/Br): TI defines "Green" to mean Pb-Free (RoHS compatible), and free of Bromine (Br) and Antimony (Sb) based flame retardants (Br or Sb do not exceed 0.1% by weight in homogeneous material)

(3) MSL, Peak Temp. -- The Moisture Sensitivity Level rating according to the JEDEC industry standard classifications, and peak solder temperature.

(4) Multiple Top-Side Markings will be inside parentheses. Only one Top-Side Marking contained in parentheses and separated by a "~" will appear on a device. If a line is indented then it is a continuation of the previous line and the two combined represent the entire Top-Side Marking for that device.

Important Information and Disclaimer:The information provided on this page represents TI's knowledge and belief as of the date that it is provided. TI bases its knowledge and belief on information provided by third parties, and makes no representation or warranty as to the accuracy of such information. Efforts are underway to better integrate information from third parties. TI has taken and continues to take reasonable steps to provide representative and accurate information but may not have conducted destructive testing or chemical analysis on incoming materials and chemicals. TI and TI suppliers consider certain information to be proprietary, and thus CAS numbers and other limited information may not be available for release.

In no event shall TI's liability arising out of such information exceed the total purchase price of the TI part(s) at issue in this document sold by TI to Customer on an annual basis.

OTHER QUALIFIED VERSIONS OF TPS2811-Q1 :

- Catalog: [TPS2811](#)

NOTE: Qualified Version Definitions:

- Catalog - TI's standard catalog product

TAPE AND REEL INFORMATION

QUADRANT ASSIGNMENTS FOR PIN 1 ORIENTATION IN TAPE

*All dimensions are nominal

Device	Package Type	Package Drawing	Pins	SPQ	Reel Diameter (mm)	Reel Width W1 (mm)	A0 (mm)	B0 (mm)	K0 (mm)	P1 (mm)	W (mm)	Pin1 Quadrant
TPS2811QPWRQ1	TSSOP	PW	8	2000	330.0	12.4	7.0	3.6	1.6	8.0	12.0	Q1

TAPE AND REEL BOX DIMENSIONS

*All dimensions are nominal

Device	Package Type	Package Drawing	Pins	SPQ	Length (mm)	Width (mm)	Height (mm)
TPS2811QPWRQ1	TSSOP	PW	8	2000	367.0	367.0	35.0

PW0008A



PACKAGE OUTLINE

TSSOP - 1.2 mm max height

SMALL OUTLINE PACKAGE



4221848/A 02/2015

NOTES:

1. All linear dimensions are in millimeters. Any dimensions in parenthesis are for reference only. Dimensioning and tolerancing per ASME Y14.5M.
2. This drawing is subject to change without notice.
3. This dimension does not include mold flash, protrusions, or gate burrs. Mold flash, protrusions, or gate burrs shall not exceed 0.15 mm per side.
4. This dimension does not include interlead flash. Interlead flash shall not exceed 0.25 mm per side.
5. Reference JEDEC registration MO-153, variation AA.

EXAMPLE BOARD LAYOUT

PW0008A

TSSOP - 1.2 mm max height

SMALL OUTLINE PACKAGE



LAND PATTERN EXAMPLE
SCALE:10X

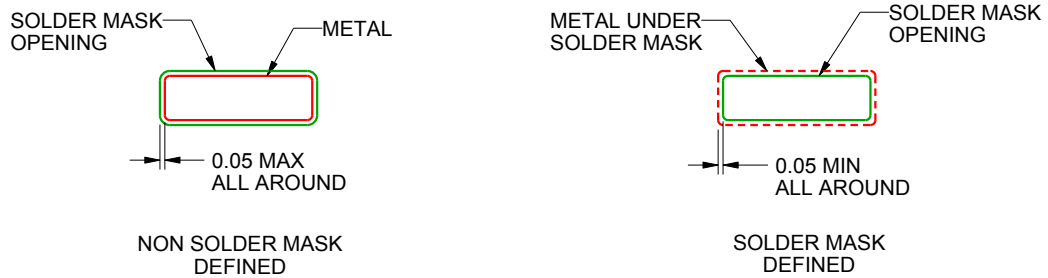

SOLDER MASK DETAILS
NOT TO SCALE

4221848/A 02/2015

NOTES: (continued)

- 6. Publication IPC-7351 may have alternate designs.
- 7. Solder mask tolerances between and around signal pads can vary based on board fabrication site.

EXAMPLE STENCIL DESIGN

PW0008A

TSSOP - 1.2 mm max height

SMALL OUTLINE PACKAGE



SOLDER PASTE EXAMPLE
BASED ON 0.125 mm THICK STENCIL
SCALE:10X

4221848/A 02/2015

NOTES: (continued)

8. Laser cutting apertures with trapezoidal walls and rounded corners may offer better paste release. IPC-7525 may have alternate design recommendations.
9. Board assembly site may have different recommendations for stencil design.

IMPORTANT NOTICE

Texas Instruments Incorporated and its subsidiaries (TI) reserve the right to make corrections, enhancements, improvements and other changes to its semiconductor products and services per JESD46, latest issue, and to discontinue any product or service per JESD48, latest issue. Buyers should obtain the latest relevant information before placing orders and should verify that such information is current and complete. All semiconductor products (also referred to herein as "components") are sold subject to TI's terms and conditions of sale supplied at the time of order acknowledgment.

TI warrants performance of its components to the specifications applicable at the time of sale, in accordance with the warranty in TI's terms and conditions of sale of semiconductor products. Testing and other quality control techniques are used to the extent TI deems necessary to support this warranty. Except where mandated by applicable law, testing of all parameters of each component is not necessarily performed.

TI assumes no liability for applications assistance or the design of Buyers' products. Buyers are responsible for their products and applications using TI components. To minimize the risks associated with Buyers' products and applications, Buyers should provide adequate design and operating safeguards.

TI does not warrant or represent that any license, either express or implied, is granted under any patent right, copyright, mask work right, or other intellectual property right relating to any combination, machine, or process in which TI components or services are used. Information published by TI regarding third-party products or services does not constitute a license to use such products or services or a warranty or endorsement thereof. Use of such information may require a license from a third party under the patents or other intellectual property of the third party, or a license from TI under the patents or other intellectual property of TI.

Reproduction of significant portions of TI information in TI data books or data sheets is permissible only if reproduction is without alteration and is accompanied by all associated warranties, conditions, limitations, and notices. TI is not responsible or liable for such altered documentation. Information of third parties may be subject to additional restrictions.

Resale of TI components or services with statements different from or beyond the parameters stated by TI for that component or service voids all express and any implied warranties for the associated TI component or service and is an unfair and deceptive business practice. TI is not responsible or liable for any such statements.

Buyer acknowledges and agrees that it is solely responsible for compliance with all legal, regulatory and safety-related requirements concerning its products, and any use of TI components in its applications, notwithstanding any applications-related information or support that may be provided by TI. Buyer represents and agrees that it has all the necessary expertise to create and implement safeguards which anticipate dangerous consequences of failures, monitor failures and their consequences, lessen the likelihood of failures that might cause harm and take appropriate remedial actions. Buyer will fully indemnify TI and its representatives against any damages arising out of the use of any TI components in safety-critical applications.

In some cases, TI components may be promoted specifically to facilitate safety-related applications. With such components, TI's goal is to help enable customers to design and create their own end-product solutions that meet applicable functional safety standards and requirements. Nonetheless, such components are subject to these terms.

No TI components are authorized for use in FDA Class III (or similar life-critical medical equipment) unless authorized officers of the parties have executed a special agreement specifically governing such use.

Only those TI components which TI has specifically designated as military grade or "enhanced plastic" are designed and intended for use in military/aerospace applications or environments. Buyer acknowledges and agrees that any military or aerospace use of TI components which have **not** been so designated is solely at the Buyer's risk, and that Buyer is solely responsible for compliance with all legal and regulatory requirements in connection with such use.

TI has specifically designated certain components as meeting ISO/TS16949 requirements, mainly for automotive use. In any case of use of non-designated products, TI will not be responsible for any failure to meet ISO/TS16949.

Products

Audio	www.ti.com/audio
Amplifiers	amplifier.ti.com
Data Converters	dataconverter.ti.com
DLP® Products	www.dlp.com
DSP	dsp.ti.com
Clocks and Timers	www.ti.com/clocks
Interface	interface.ti.com
Logic	logic.ti.com
Power Mgmt	power.ti.com
Microcontrollers	microcontroller.ti.com
RFID	www.ti-rfid.com
OMAP Applications Processors	www.ti.com/omap
Wireless Connectivity	www.ti.com/wirelessconnectivity

Applications

Automotive and Transportation	www.ti.com/automotive
Communications and Telecom	www.ti.com/communications
Computers and Peripherals	www.ti.com/computers
Consumer Electronics	www.ti.com/consumer-apps
Energy and Lighting	www.ti.com/energy
Industrial	www.ti.com/industrial
Medical	www.ti.com/medical
Security	www.ti.com/security
Space, Avionics and Defense	www.ti.com/space-avionics-defense
Video and Imaging	www.ti.com/video

TI E2E Community

e2e.ti.com

Looking for pricing, stock, or lifecycle information?

Click below to explore more details on WIN SOURCE:

 [View TPS2811QPWRQ1](#) on WIN SOURCE

 [Texas Instruments](#) Information

Optimize Your Supply Chain with WIN SOURCE Solutions

-  Global Sourcing Solution
-  Obsolete Management
-  Cost Control Management
-  Shortage Management
-  Alternative Solution
-  Excess Inventory Management