



**THE DATASHEET OF  
ISL33337EIRZ**



## ISL33334E, ISL33337E

3.3V, ±15kV ESD Protected, Two Port, Dual Protocol (RS-232/RS-485) Transceivers

FN8776  
Rev 1.00  
October 21, 2016

The [ISL33334E](#), [ISL33337E](#) are two port interface ICs where port 1 is configured as a dual (2 Tx, 2 Rx) RS-232 transceiver and port 2 is a single RS-485/RS-422 transceiver.

The on-board charge pump generates RS-232 compliant ±5V Tx output levels from a single V<sub>CC</sub> supply as low as 3.15V. The transceivers are RS-232 compliant, with the Rx inputs handling up to ±25V.

The port 2 transceiver supports both the RS-485 and RS-422 differential communication standards. The receiver features “full fail-safe” operation, so the Rx output remains in a high state if the inputs are open or shorted together. The transmitter supports two data rates, one of which is slew rate limited for problem free communication at low data rates. The active low Rx enable pin ( $\overline{RE485}$ ) allows Tx/Rx direction control, via a single signal, simply by connecting the corresponding DE485 and  $\overline{RE485}$  pins together.

The ISL33334E and ISL33337E also include a shutdown function, which disables the Tx and Rx outputs, disables the charge pumps and places the IC in a low current (40µA) mode.

The ISL33337E is a QFN packaged device for space constrained applications.

### Related Literature

- For a full list of related documents, visit our website
  - [ISL33334E](#), [ISL33337E](#) product pages

### Features

- ±15kV (HBM) ESD protected bus pins (RS-232 or RS-485)
- Operates from a single 3.3V supply
- Two independent ports, port 1 set for RS-232 (2 Transceivers) and port 2 for RS-485/RS-422 (1 transceiver)
- True flow-through pinouts (Rx inputs and Tx outputs all on the same side) simplify board layouts
- Pb-free (RoHS compliant)
- Full fail-safe (open/short) RS-485/422 Port 2 Rx
- User selectable RS-485 data rates
  - Fast speed. . . . . up to 20Mbps
  - Slew rate limited . . . . . up to 115kbps
- Fast RS-232 data rate . . . . . up to 400kbps
- Small charge pump capacitors . . . . . 4 x 0.1µF
- Low current shutdown mode . . . . . 40µA
- QFN package saves board space (ISL33337E only)

### Applications

- Gaming applications (e.g., slot machines)
- Single board computers
- Factory automation
- Security networks
- Industrial/process control networks
- Level translators (e.g., RS-232 to RS-422)
- Point-of-sale equipment

TABLE 1. SUMMARY OF FEATURES

PART NUMBER	PACKAGE OPTION	PORT 2 RS-485 DATA RATE (bps)	PORT 1 RS-232 DATA RATE (bps)	LOW POWER SHUTDOWN?	PORT 2 RS-485 Rx AND Tx ENABLE?
ISL33334E	28 Ld SSOP	20M, 115k	400k	YES	YES
ISL33337E	40 Ld QFN (6x6mm)	20M, 115k	400k	YES	YES

## Ordering Information

PART NUMBER (Notes 2, 3)	PART MARKING	TEMP. RANGE (°C)	TAPE AND REEL (UNITS)	PACKAGE (RoHS COMPLIANT)	PKG. DWG. #
ISL33334EIAZ	33334E IAZ	-40 to +85	-	28 Ld SSOP	M28.209
ISL33334EIAZ-T (Notes 1)	33334E IAZ	-40 to +85	1k	28 Ld SSOP	M28.209
ISL33337EIRZ	33337E IRZ	-40 to +85	-	40 Ld QFN	L40.6x6
ISL33337EIRZ-T (Notes 1)	33337E IRZ	-40 to +85	1k	40 Ld QFN	L40.6x6
ISL33337EIRZ-T7A (Notes 1)	33337E IRZ	-40 to +85	250	40 Ld QFN	L40.6x6

**NOTES:**

1. Refer to [TB347](#) for details on reel specifications.
2. These Intersil Pb-free plastic packaged products employ special Pb-free material sets, molding compounds/die attach materials and 100% matte tin plate plus anneal (e3 termination finish, which is RoHS compliant and compatible with both SnPb and Pb-free soldering operations). Intersil Pb-free products are MSL classified at Pb-free peak reflow temperatures that meet or exceed the Pb-free requirements of IPC/JEDEC J STD-020.
3. For Moisture Sensitivity Level (MSL), see product information page for [ISL33334E](#), [ISL33337E](#). For more information on MSL, see tech brief [TB363](#).

**TABLE 2. KEY DIFFERENCES BETWEEN FAMILY OF PARTS**

PART NUMBER	VCC (V)	PKG	RS485 (bps) DATA RATE	RS232 (bps) DATA RATE
ISL33354E	5	28Ld SSOP	20M, 115k	650k
ISL33357E	5	40Ld QFN	20M, 115k	650k
ISL33334E	3.3	28Ld SSOP	20M, 115k	400k
ISL33337E	3.3	40Ld QFN	20M, 115k	400k

NOTE: For a full list of dual protocol transceivers, please visit our [website](#).

## Pin Configurations

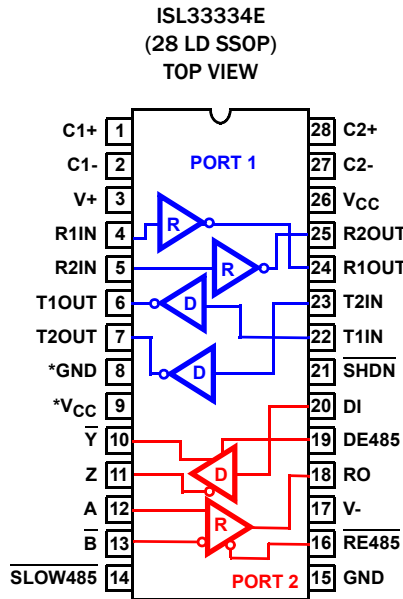

\* NOT A SUPPLY PIN, BUT MUST BE CONNECTED TO THE NOTED SUPPLY.

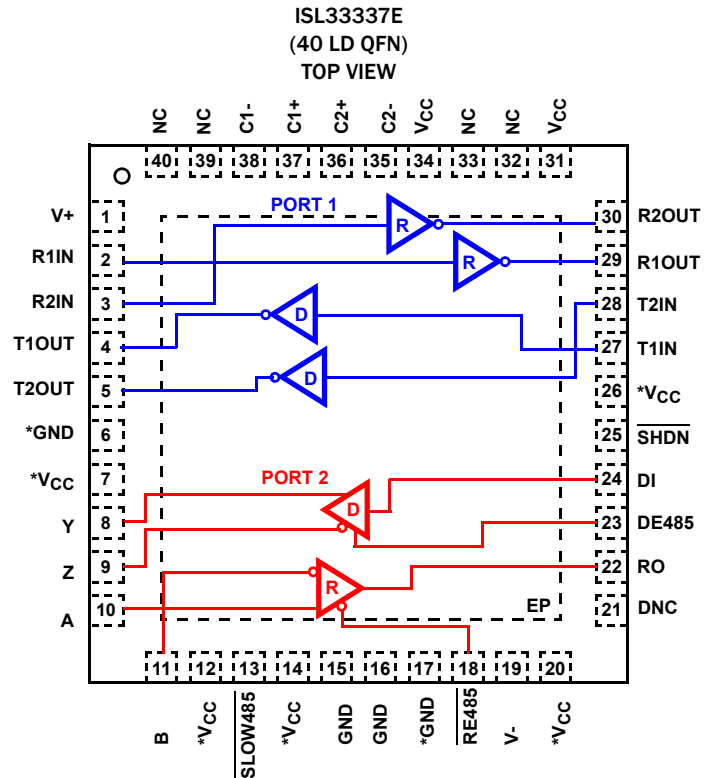

## Pin Descriptions

PIN NAME	PIN # for SSOP	PIN # for QFN	PORT/ MODE	FUNCTION
NC	-	32, 33, 39, 40	BOTH	No Internal Connection.
DNC	-	21	BOTH	Do not make any external connections to this pin.
SHDN	21	25	BOTH	A low on $\overline{\text{SHDN}}$ disables the charge pumps, disables all the outputs and places the device in low power shutdown. Internally pulled-high. $\overline{\text{SHDN}} = 1$ for normal operation.
V <sub>CC</sub>	26	31, 34	BOTH	System power supply input (3.15V to 3.45V). Both pins 31 and 34 must connect to the V <sub>CC</sub> supply.
GND	15	15, 16	BOTH	Ground connection. QFN pins 15 and 16 must both connect to GND. This is also the potential of the QFN's exposed metal pad (EP).
*V <sub>CC</sub>	9	12, 20, 7, 14, 26	BOTH	For proper operation, connect this lead to the V <sub>CC</sub> supply. This is not a power supply lead, so no decoupling is required.
*GND	8	6, 17	BOTH	For proper operation, connect this lead to GND. This is not a power supply lead.
RxIN	4, 5	2, 3	1 / RS-232	RS-232 receiver input with $\pm 15\text{kV}$ ESD protection. A low on RxIN forces RxOUT high; a high on RxIN forces RxOUT low.
RxOUT	24, 25	29, 30	1 / RS-232	RS-232 receiver output.
TxIN	22, 23	27, 28	1 / RS-232	RS-232 transmitter input. A low on TxIN drives the corresponding TxOUT high, while a high on TxIN drives the corresponding TxOUT low.
TxOUT	6, 7	4, 5	1 / RS-232	RS-232 transmitter output with $\pm 15\text{kV}$ ESD protection.
C1+	1	37	1 / RS-232	External charge pump capacitor is connected to this lead.
C1-	2	38	1 / RS-232	External charge pump capacitor is connected to this lead.
C2+	28	36	1 / RS-232	External charge pump capacitor is connected to this lead.
C2-	27	35	1 / RS-232	External charge pump capacitor is connected to this lead.
V+	3	1	1 / RS-232	Internally generated positive RS-232 transmitter supply (+5.5V).
V-	17	19	1 / RS-232	Internally generated negative RS-232 transmitter supply (-5.5V).
A	12	10	2 / RS-485	RS-485 noninverting receiver input with $\pm 15\text{kV}$ ESD protection.
$\overline{\text{B}}$	13	11	2 / RS-485	RS-485 inverting receiver input with $\pm 15\text{kV}$ ESD protection.
$\overline{\text{Y}}$	10	8	2 / RS-485	RS-485 noninverting driver output with $\pm 15\text{kV}$ ESD protection.
Z	11	9	2 / RS-485	RS-485 inverting driver output with $\pm 15\text{kV}$ ESD protection.
DI	20	24	2 / RS-485	RS-485 driver input. A low on DI forces output Y low and output Z high.
RO	18	22	2 / RS-485	RS-485 receiver output: If A > B by at least -40mV, RO is high; If A < B by -200mV or more, RO is low; RO = High if A and B are unconnected (floating) or shorted together (i.e., full fail-safe).
$\overline{\text{SLOW485}}$	14	13	2 / RS-485	RS-485 data rate control. A low on $\overline{\text{SLOW485}}$ selects the 115kbps RS-485 data rate (slew rate limited output transitions); a high selects the 20Mbps data rate (full speed transitions). Internally pulled-high.
RE485	16	18	2 / RS-485	RS-485 active low receiver output enable. RO is enabled when $\overline{\text{RE485}}$ is low; RO is high impedance when $\overline{\text{RE485}}$ is high. Internally pulled low.
DE485	19	23	2 / RS-485	RS-485 driver output enable (DE). The driver outputs, Y and Z, are enabled by driving DE485 high. They are high impedance when DE485 is low. Internally pulled high.
EP	-	EP	BOTH	QFN exposed thermal pad (EPAD). Connect to GND.

TABLE 3. ISL33334E AND ISL33337E FUNCTION TABLE

INPUTS					RECEIVER OUTPUTS		DRIVER OUTPUTS		CHARGE PUMPS (Note 4)	DRIVER DATA RATE (bps)	MODE
PORT	$\overline{\text{SHDN}}$	$\overline{\text{RE485}}$	DE485	$\overline{\text{SLOW485}}$	RO	R1OUT AND R2OUT	Y AND Z	T1OUT AND T2OUT			
1	1	N.A.	N.A.	N.A.	N.A.	ON	N.A.	ON	ON	400k	RS-232

TABLE 3. ISL33334E AND ISL33337E FUNCTION TABLE

INPUTS					RECEIVER OUTPUTS		DRIVER OUTPUTS		CHARGE PUMPS (Note 4)	DRIVER DATA RATE (bps)	MODE
PORT	SHDN	RE485	DE485	SLOW485	RO	R1OUT AND R2OUT	Y AND Z	T1OUT AND T2OUT			
2	1	0	0	0	ON	N.A.	High-Z	N.A.	ON	115k	RS-485 Rx
2	1	0	1	0	ON	N.A.	ON	N.A.	ON	115k	RS-485 Tx and Rx
2	1	1	1	0	High-Z	N.A.	ON	N.A.	ON	115k	RS-485 Tx
2	1	0	0	1	ON	N.A.	High-Z	N.A.	ON	20M	RS-485 Rx
2	1	0	1	1	ON	N.A.	ON	N.A.	ON	20M	RS-485 Tx and Rx
2	1	1	1	1	High-Z	N.A.	ON	N.A.	ON	20M	RS-485 Tx
1 AND 2	0	X	X	X	High-Z	High-Z	High-Z	High-Z	OFF	N.A.	Shutdown

NOTE:

4. Charge pumps are off if SHDN = 0. If SHDN = 1, the charge pumps are on.

## Truth Tables

RS-232 TRANSMITTING (PORT 1)				
INPUTS			OUTPUTS	
SHDN	T1IN	T2IN	T1OUT	T2OUT
1	0	0	1	1
1	0	1	1	0
1	1	0	0	1
1	1	1	0	0
0	X	X	High-Z	High-Z

RS-232 RECEIVING (PORT 1)				
INPUTS			OUTPUTS	
SHDN	R1IN	R2IN	R1OUT	R2OUT
1	0	0	1	1
1	0	1	1	0
1	1	0	0	1
1	1	1	0	0
1	Open	Open	1	1
0	X	X	High-Z	High-Z

RS-485 TRANSMITTING (PORT 2)						
INPUTS				OUTPUTS		
SHDN	DE485	DI	SLOW485	Y	Z	DATA RATE (bps)
1	1	0	0	0	1	115k
1	1	1	0	1	0	115k
1	1	0	1	0	1	20M
1	1	1	1	1	0	20M
1	0	X	X	High-Z	High-Z	N.A.
0	X	X	X	High-Z	High-Z	N.A.

RS-485 RECEIVING (PORT 2)			
INPUTS			OUTPUT
SHDN	RE485	A-B	RO
1	0	≥-40mV	1
1	0	≤-200mV	0
1	0	Open or Shorted together	1
1	1	X	High-Z
0	X	X	High-Z

## Typical Operating Circuits

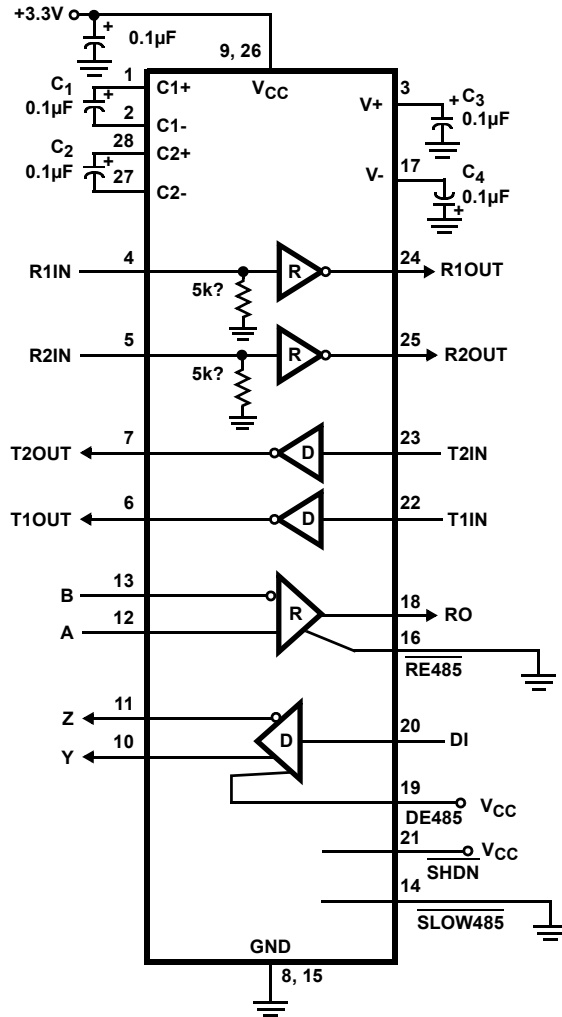

NOTE: PINOUT FOR SSOP

FIGURE 1. PORT RS-232 MODE AND 1 PORT RS-485 MODE

**Absolute Maximum Ratings** ( $T_A = +25^\circ\text{C}$ )

$V_{CC}$ to Ground	7V
Input Voltages	
All Except A,B, RxIN	-0.5V to 7V
Input/Output Voltages	
A, B, RxIN	-25V to +25V
Y, Z, TxOUT (Note 5)	-12.5V to +12.5V
RO, RxOUT	-0.5V to ( $V_{CC} + 0.5V$ )
Output Short-circuit Duration	
Y, Z, TxOUT, RxOUT	Indefinite
ESD Rating	See Specification Table on <a href="#">page 7</a>
Latch-up (per JESD78D, Level 2, Class A)	+85°C

**Thermal Information**

Thermal Resistance (Typical)	$\theta_{JA}$ ( $^\circ\text{C}/\text{W}$ )	$\theta_{JC}$ ( $^\circ\text{C}/\text{W}$ )
28 Ld SSOP Package (Notes 7, 9)	60	36
40 Ld QFN Package (Notes 6, 8)	32	2.5
Maximum Junction Temperature (Plastic Package)	+150°C	
Maximum Storage Temperature Range	-65°C to +150°C	
Pb-free Reflow Profile	see <a href="#">TB493</a>	

**Recommended Operating Conditions**

Supply Voltage ( $V_{CC}$ )	3.3V
Temperature Range	-40°C to +85°C
RS-485 Tx Load	One or two 120Ω Terminations

**CAUTION:** Do not operate at or near the maximum ratings listed for extended periods of time. Exposure to such conditions may adversely impact product reliability and result in failures not covered by warranty.

**NOTES:**

- One output at a time,  $I_{OUT} \leq 100\text{mA}$  for  $\leq 10$  mins.
- $\theta_{JA}$  is measured in free air with the component mounted on a high effective thermal conductivity test board with "direct attach" features. See Tech Brief [TB379](#).
- $\theta_{JA}$  is measured with the component mounted on a high effective thermal conductivity test board in free air. See Tech Brief [TB379](#) for details.
- For  $\theta_{JC}$ , the "case temp" location is the center of the exposed metal pad on the package underside.
- For  $\theta_{JC}$ , the "case temp" location is taken at the package top center.

**Electrical Specifications** Test Conditions:  $V_{CC} = 3.15\text{V}$  to  $3.45\text{V}$ ,  $C_1 - C_4 = 0.1\mu\text{F}$ ; unless otherwise specified. Typicals are at  $V_{CC} = 3.3\text{V}$ ,  $T_A = +25^\circ\text{C}$  (Note 10). **Boldface limits apply across the operating temperature range, -40°C to +85°C.**

PARAMETER	SYMBOL	TEST CONDITIONS	TEMP ( $^\circ\text{C}$ )	MIN (Note 14)	TYP	MAX (Note 14)	UNIT	
<b>DC CHARACTERISTICS - RS-485 DRIVER (PORT 2)</b>								
Driver Differential $V_{OUT}$ (no load)	$V_{OD1}$		Full	-	-	$V_{CC}$	V	
Driver Differential $V_{OUT}$ (with load)	$V_{OD2}$	$R = 50\Omega$ (RS-422) (Figure 2)	Full	<b>2</b>	2.3	-	V	
		$R = 27\Omega$ (RS-485) (Figure 2)	Full	<b>1.5</b>	2	<b>5</b>	V	
	$V_{OD3}$	$R_D = 60\Omega$ , $R = 375\Omega$ , $V_{CM} = -7\text{V}$ to $12\text{V}$ (Figure 2)	Full	<b>1.5</b>	-	<b>5</b>	V	
Change in Magnitude of Driver Differential $V_{OUT}$ for Complementary Output States	$\Delta V_{OD}$	$R = 27\Omega$ or $50\Omega$ (Figure 2)	Full	-	0.01	<b>0.2</b>	V	
Driver Common-Mode $V_{OUT}$	$V_{OC}$	$R = 27\Omega$ or $50\Omega$ (Figure 2)	Full	-	-	<b>3</b>	V	
Change in Magnitude of Driver Common-Mode $V_{OUT}$ for Complementary Output States	$\Delta V_{OC}$	$R = 27\Omega$ or $50\Omega$ (Figure 2)	Full	-	0.01	<b>0.2</b>	V	
Driver Short-Circuit Current, $V_{OUT} = \text{High or Low}$	$I_{OS}$	$-7\text{V} \leq (V_Y \text{ or } V_Z) \leq 12\text{V}$ (Note 12)	Full	<b>35</b>	-	<b>250</b>	mA	
Driver Three-State Output Leakage Current (Y, Z)	$I_{OZ}$	Outputs disabled, $V_{CC} = 0\text{V}$ or $3.6\text{V}$	$V_{OUT} = 12\text{V}$	Full	-	-	<b>200</b>	$\mu\text{A}$
			$V_{OUT} = -7\text{V}$	Full	<b>-200</b>	-	-	$\mu\text{A}$
<b>DC CHARACTERISTICS - RS-232 DRIVER (PORT 1)</b>								
Driver Output Voltage Swing	$V_O$	All $T_{OUTS}$ loaded with $3\text{k}\Omega$ to ground	Full	<b><math>\pm 5</math></b>	-	-	V	
Driver Output Short-Circuit Current	$I_{OS}$	$V_{OUT} = 0\text{V}$	Full	<b>-60</b>	-	<b>60</b>	mA	
<b>DC CHARACTERISTICS - LOGIC PINS (i.e., DRIVER AND CONTROL INPUT PINS)</b>								
Input High Voltage	$V_{IH}$		Full	<b>2.2</b>	-	-	V	
Input Low Voltage	$V_{IL}$		Full	-	-	<b>0.8</b>	V	
Input Current	$I_{IN1}$	Pins Without Pull ups or Pull downs	Full	<b>-2</b>	-	<b>2</b>	$\mu\text{A}$	
	$I_{IN2}$	SLOW485, DE485, RE485, SHDN	Full	<b>-25</b>	-	<b>25</b>	$\mu\text{A}$	

**Electrical Specifications** Test Conditions:  $V_{CC} = 3.15V$  to  $3.45V$ ,  $C_1 - C_4 = 0.1\mu F$ ; unless otherwise specified. Typicals are at  $V_{CC} = 3.3V$ ,  $T_A = +25^\circ C$  (Note 10). (Continued) **Boldface limits apply across the operating temperature range,  $-40^\circ C$  to  $+85^\circ C$ . (Continued)**

PARAMETER	SYMBOL	TEST CONDITIONS	TEMP ( $^\circ C$ )	MIN (Note 14)	TYP	MAX (Note 14)	UNIT	
<b>DC CHARACTERISTICS - RS-485 RECEIVER INPUTS (PORT 2)</b>								
Receiver Differential Threshold Voltage	$V_{TH}$	$-7V \leq V_{CM} \leq 12V$ , full fail-safe	Full	<b>-0.2</b>	-	<b>-0.04</b>	V	
Receiver Input Hysteresis	$\Delta V_{TH}$	$V_{CM} = 0V$	25	-	35	-	mV	
Receiver Input Current (A, B)	$I_{IN}$	$V_{CC} = 0V$ or $3.0$ to $3.6V$	$V_{IN} = 12V$	Full	-	-	<b>0.8</b>	mA
			$V_{IN} = -7V$	Full	<b>-0.64</b>	-	-	mA
Receiver Input Resistance	$R_{IN}$	$-7V \leq V_{CM} \leq 12V$ , $V_{CC} = 0$ (Note 13) or $3V \leq V_{CC} \leq 3.6V$	Full	<b>15</b>	-	-	k $\Omega$	
<b>DC CHARACTERISTICS - RS-232 RECEIVER INPUTS (PORT 1)</b>								
Receiver Input Voltage Range	$V_{IN}$		Full	<b>-25</b>	-	<b>25</b>	V	
Receiver Input Threshold	$V_{IL}$		Full	-	1.1	<b>0.8</b>	V	
	$V_{IH}$		Full	<b>2.4</b>	1.6	-	V	
Receiver Input Hysteresis	$\Delta V_{TH}$		25	-	0.5	-	V	
Receiver Input Resistance	$R_{IN}$	$V_{IN} = \pm 15V$ , $V_{CC}$ powered up (Note 13)	Full	<b>3</b>	5	<b>7</b>	k $\Omega$	
<b>DC CHARACTERISTICS - RECEIVER OUTPUTS (PORT 1 and 2)</b>								
Receiver Output High Voltage	$V_{OH}$	$I_O = -1.5mA$	Full	<b><math>V_{CC}-0.4</math></b>	-	-	V	
Receiver Output Low Voltage	$V_{OL}$	$I_O = 5mA$	Full	-	0.2	<b>0.4</b>	V	
Receiver Short-Circuit Current	$I_{OSR}$	$0V \leq V_O \leq V_{CC}$	Full	<b>7</b>	-	<b>85</b>	mA	
Receiver Three-State Output Current	$I_{OZR}$	Output Disabled, $0V \leq V_O \leq V_{CC}$	Full	-	-	<b><math>\pm 10</math></b>	$\mu A$	
<b>POWER SUPPLY CHARACTERISTICS</b>								
No-Load Supply Current, (Note 11)	$I_{CC}$	$\overline{SHDN} = V_{CC}$	Full	-	3.7	<b>7</b>	mA	
Shutdown Supply Current	$I_{SHDN}$	$\overline{SHDN} = \overline{SLOW485} = GND$ , $\overline{RE485} = V_{CC}$ , $\overline{DE485} = GND$	Full	-	40	<b>160</b>	$\mu A$	
<b>ESD CHARACTERISTICS</b>								
Bus Pins (A, B, Y, Z, RxIN, TxOUT) Any Port		Human body model	25	-	$\pm 15$	-	kV	
All Other Pins		Human body model	25	-	$\pm 2.5$	-	kV	
		Machine model	25	-	$\pm 200$	-	V	
<b>RS-232 DRIVER AND RECEIVER SWITCHING CHARACTERISTICS (PORT 1, ALL VERSIONS AND SPEEDS)</b>								
Driver Output Transition Region Slew Rate	SR	$R_L = 3k\Omega$ , Measured From $3V$ to $-3V$ or $-3V$ to $3V$	$C_L \geq 15pF$	Full	-	20	<b>30</b>	V/ $\mu s$
			$C_L \leq 2500pF$	Full	<b>4</b>	9	-	V/ $\mu s$
Driver Output Transition Time	$t_r, t_f$	$R_L = 3k\Omega$ , $C_L = 2500pF$ , 10% - 90%	Full	<b>0.22</b>	1.2	<b>3.1</b>	$\mu s$	
Driver Propagation Delay	$t_{DPHL}$	$R_L = 3k\Omega$ , $C_L = 1000pF$ (Figure 7)	Full	-	1	<b>2</b>	$\mu s$	
	$t_{DPLH}$		Full	-	1.2	<b>2</b>	$\mu s$	
Driver Propagation Delay Skew	$t_{DSKEW}$	$t_{DPHL} - t_{DPLH}$ (Figure 7)	Full	-	300	<b>450</b>	ns	
Driver Enable Time from Shutdown	$t_{DENSD}$	$V_{OUT} = \pm 3.0V$ , $C_L = 1000pF$	25	-	25	-	$\mu s$	
Driver Maximum Data Rate	$DR_D$	$R_L = 3k\Omega$ , $C_L = 500pF$ , One Transmitter Switching	Full	<b>250</b>	400	-	kbps	
Receiver Propagation Delay	$t_{RPHL}$	$C_L = 15pF$ (Figure 8)	Full	-	40	<b>120</b>	ns	
	$t_{RPLH}$		Full	-	58	<b>120</b>	ns	

**Electrical Specifications** Test Conditions:  $V_{CC} = 3.15V$  to  $3.45V$ ,  $C_1 - C_4 = 0.1\mu F$ ; unless otherwise specified. Typical values are at  $V_{CC} = 3.3V$ ,  $T_A = +25^\circ C$  (Note 10). (Continued) **Boldface limits apply across the operating temperature range,  $-40^\circ C$  to  $+85^\circ C$ .** (Continued)

PARAMETER	SYMBOL	TEST CONDITIONS	TEMP ( $^\circ C$ )	MIN (Note 14)	TYP	MAX (Note 14)	UNIT
Receiver Propagation Delay Skew	$t_{RSKEW}$	$t_{RPHL} - t_{RPLH}$ (Figure 8)	Full	-	18	<b>40</b>	ns
Receiver Maximum Data Rate	$DR_R$	$C_L = 15pF$	Full	<b>0.46</b>	2	-	Mbps
<b>RS-485 DRIVER SWITCHING CHARACTERISTICS (FAST DATA RATE (20Mbps), PORT 2, (SLOW485 = <math>V_{CC}</math>))</b>							
Driver Differential Input to Output Delay	$t_{DLH}, t_{DHL}$	$R_{DIFF} = 54\Omega, C_L = 100pF$ (Figure 3)	Full	<b>10</b>	20	<b>35</b>	ns
Driver Output Skew	$t_{SKEW}$	$R_{DIFF} = 54\Omega, C_L = 100pF$ (Figure 3)	Full	-	2	<b>10</b>	ns
Driver Differential Rise or Fall Time	$t_R, t_F$	$R_{DIFF} = 54\Omega, C_L = 100pF$ (Figure 3)	Full	<b>3</b>	20	<b>30</b>	ns
Driver Enable to Output Low	$t_{ZL}$	$C_L = 100pF, SW = V_{CC}$ (Figure 4)	Full	-	28	<b>60</b>	ns
Driver Enable to Output High	$t_{ZH}$	$C_L = 100pF, SW = GND$ (Figure 4)	Full	-	35	<b>60</b>	ns
Driver Disable from Output Low	$t_{LZ}$	$C_L = 15pF, SW = V_{CC}$ (Figure 4)	Full	-	30	<b>60</b>	ns
Driver Disable from Output High	$t_{HZ}$	$C_L = 15pF, SW = GND$ (Figure 4)	Full	-	30	<b>60</b>	ns
Driver Enable from Shutdown to Output Low	$t_{ZL(SHDN)}$	$R_L = 500\Omega, C_L = 100pF, SW = V_{CC}$ (Figure 4)	Full	-	100	<b>250</b>	ns
Driver Enable from Shutdown to Output High	$t_{ZH(SHDN)}$	$R_L = 500\Omega, C_L = 100pF, SW = GND$ (Figure 4)	Full	-	290	<b>375</b>	ns
Driver Maximum Data Rate	$f_{MAX}$	$R_{DIFF} = 54\Omega, C_L = 100pF$ (Figure 3)	Full	<b>20</b>	35	-	Mbps
<b>RS-485 DRIVER SWITCHING CHARACTERISTICS (SLOW DATA RATE (115kbps), PORT 2, (SLOW485 = GND))</b>							
Driver Differential Input to Output Delay	$t_{DLH}, t_{DHL}$	$R_{DIFF} = 54\Omega, C_L = 100pF$ (Figure 3)	Full	<b>800</b>	1600	<b>2500</b>	ns
Driver Output Skew	$t_{SKEW}$	$R_{DIFF} = 54\Omega, C_L = 100pF$ (Figure 3)	Full	-	250	<b>500</b>	ns
Driver Differential Rise or Fall Time	$t_R, t_F$	$R_{DIFF} = 54\Omega, C_L = 100pF$ (Figure 3)	Full	<b>1000</b>	1700	<b>3100</b>	ns
Driver Enable to Output Low	$t_{ZL}$	$C_L = 100pF, SW = V_{CC}$ (Figure 4)	Full	-	45	<b>100</b>	ns
Driver Enable to Output High	$t_{ZH}$	$C_L = 100pF, SW = GND$ (Figure 4)	Full	-	900	<b>1200</b>	ns
Driver Disable from Output Low	$t_{LZ}$	$C_L = 15pF, SW = V_{CC}$ (Figure 4)	Full	-	35	<b>60</b>	ns
Driver Disable from Output High	$t_{HZ}$	$C_L = 15pF, SW = GND$ (Figure 4)	Full	-	25	<b>60</b>	ns
Driver Enable from Shutdown to Output Low	$t_{ZL(SHDN)}$	$R_L = 500\Omega, C_L = 100pF, SW = V_{CC}$ (Figure 4)	Full	-	-	<b>800</b>	ns
Driver Enable from Shutdown to Output High	$t_{ZH(SHDN)}$	$R_L = 500\Omega, C_L = 100pF, SW = GND$ (Figure 4)	Full	-	-	<b>1500</b>	ns
Driver Maximum Data Rate	$f_{MAX}$	$R_{DIFF} = 54\Omega, C_L = 100pF$ (Figure 3)	Full	<b>115</b>	800	-	kbps
<b>RS-485 RECEIVER SWITCHING CHARACTERISTICS (PORT 2, ALL SPEEDS)</b>							
Receiver Input to Output Delay	$t_{PLH}, t_{PHL}$	(Figure 5)	Full	<b>20</b>	45	<b>70</b>	ns
Receiver Skew   $t_{PLH} - t_{PHL}$	$t_{SKEW}$	(Figure 5)	Full	-	3	<b>10</b>	ns
Receiver Maximum Data Rate	$f_{MAX}$		Full	<b>20</b>	40	-	Mbps
Receiver Enable to Output Low	$t_{ZL}$	$C_L = 15pF, SW = V_{CC}$ (Figure 6)	Full	-	20	<b>60</b>	ns
Receiver Enable to Output High	$t_{ZH}$	$C_L = 15pF, SW = GND$ (Figure 6)	Full	-	20	<b>60</b>	ns
Receiver Disable from Output Low	$t_{LZ}$	$C_L = 15pF, SW = V_{CC}$ (Figure 6)	Full	-	20	<b>60</b>	ns
Receiver Disable from Output High	$t_{HZ}$	$C_L = 15pF, SW = GND$ (Figure 6)	Full	-	20	<b>60</b>	ns
Receiver Enable from Shutdown to Output Low	$t_{ZLSHDN}$	$C_L = 15pF, SW = V_{CC}$ (Figure 6)	Full	-	500	<b>900</b>	ns
Receiver Enable from Shutdown to Output High	$t_{ZHSHDN}$	$C_L = 15pF, SW = GND$ (Figure 6)	Full	-	500	<b>900</b>	ns

**Electrical Specifications** Test Conditions:  $V_{CC} = 3.15V$  to  $3.45V$ ,  $C_1 - C_4 = 0.1\mu F$ ; unless otherwise specified. Typicals are at  $V_{CC} = 3.3V$ ,  $T_A = +25^\circ C$  (Note 10). (Continued) **Boldface limits apply across the operating temperature range,  $-40^\circ C$  to  $+85^\circ C$ .** (Continued)

PARAMETER	SYMBOL	TEST CONDITIONS	TEMP ( $^\circ C$ )	MIN (Note 14)	TYP	MAX (Note 14)	UNIT
-----------	--------	-----------------	------------------------	------------------	-----	------------------	------

NOTES:

- 10. All currents into device pins are positive; all currents out of device pins are negative. All voltages are referenced to device ground unless otherwise specified.
- 11. Supply current specification is valid for loaded RS-485 (port 2) drivers when DE485 = 0V.
- 12. Applies to peak current. See "Typical Performance Curves on page 12" for more information.
- 13. A, B, RxIN defaults to RS-485 mode ( $>15k\Omega$ ) when the device is unpowered ( $V_{CC} = 0V$ ), or in SHDN.
- 14. Compliance to datasheet limits is assured by one or more methods: production test, characterization and/or design.

## Test Circuits and Waveforms

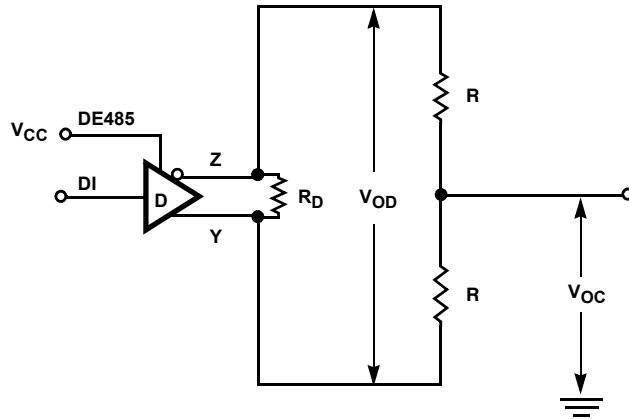

FIGURE 2. RS-485 DRIVER  $V_{OD}$  AND  $V_{OC}$  TEST CIRCUIT

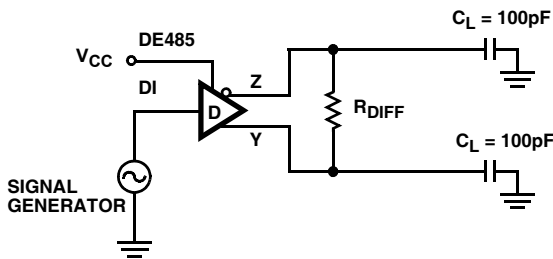
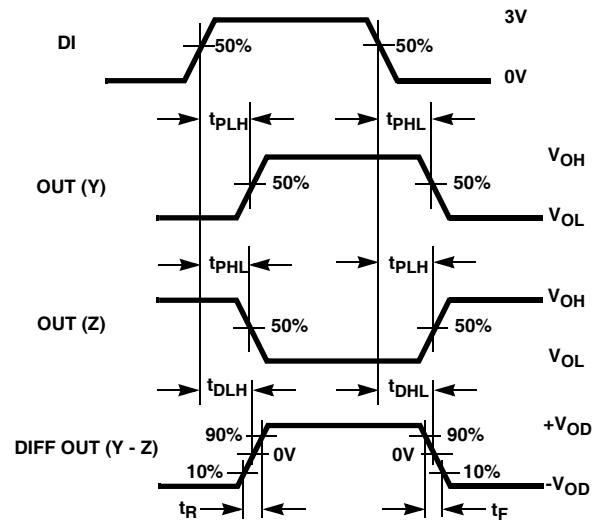

FIGURE 3A. TEST CIRCUIT



$$SKEW = |t_{PLH}(Y \text{ or } Z) - t_{PHL}(Z \text{ or } Y)|$$

FIGURE 3B. MEASUREMENT POINTS

FIGURE 3. RS-485 DRIVER PROPAGATION DELAY AND DIFFERENTIAL TRANSITION TIMES

## Test Circuits and Waveforms (Continued)

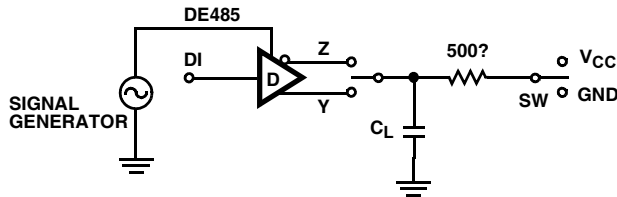

FOR SHDN TESTS, SWITCH  $\overline{\text{SHDN}}$  RATHER THAN DE485

PARAMETER	SHDN/DE485	OUTPUT	DI	SW	CL (pF)
$t_{HZ}$	1/-	Y/Z	1/0	GND	15
$t_{LZ}$	1/-	Y/Z	0/1	V <sub>CC</sub>	15
$t_{ZH}$	1/-	Y/Z	1/0	GND	100
$t_{ZL}$	1/-	Y/Z	0/1	V <sub>CC</sub>	100
$t_{ZH}(\text{SHDN})$	-/1	Y/Z	1/0	GND	100
$t_{ZL}(\text{SHDN})$	-/1	Y/Z	0/1	V <sub>CC</sub>	100

FIGURE 4A. TEST CIRCUIT

FIGURE 4. RS-485 DRIVER ENABLE AND DISABLE TIMES

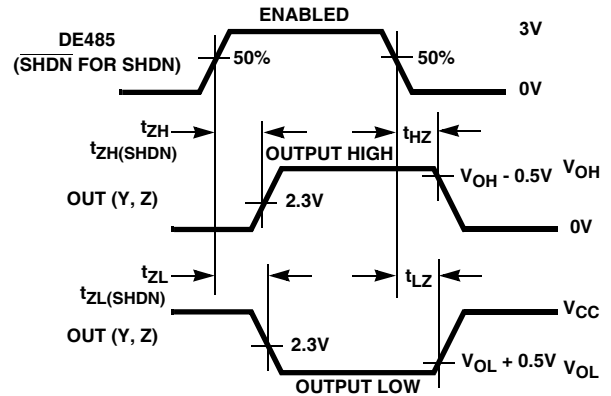

FIGURE 4B. MEASUREMENT POINTS

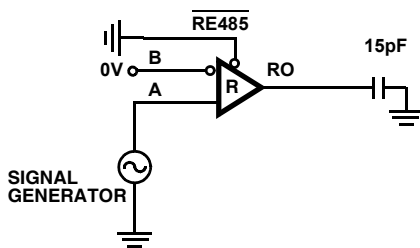

FIGURE 5A. TEST CIRCUIT

FIGURE 5. RS-485 RECEIVER PROPAGATION DELAY

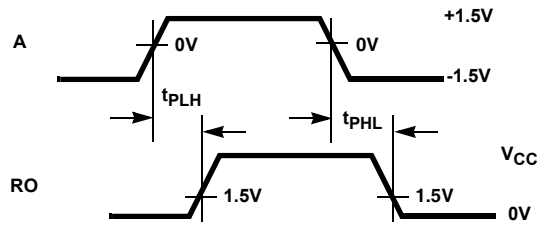
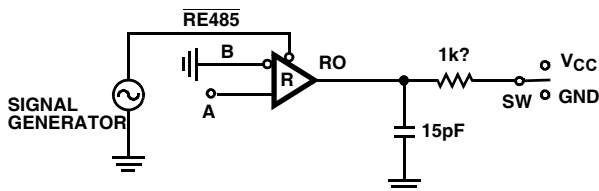

FIGURE 5B. MEASUREMENT POINTS



FOR SHDN TESTS, SWITCH  $\overline{\text{SHDN}}$  RATHER THAN RE485

PARAMETER	SHDN/RE485	A	SW
$t_{HZ}$	1/-	+1.5V	GND
$t_{LZ}$	1/-	-1.5V	V <sub>CC</sub>
$t_{ZH}$	1/-	+1.5V	GND
$t_{ZL}$	1/-	-1.5V	V <sub>CC</sub>
$t_{ZH}(\text{SHDN})$	-/0	+1.5V	GND
$t_{ZL}(\text{SHDN})$	-/0	-1.5V	V <sub>CC</sub>

FIGURE 6A. TEST CIRCUIT

FIGURE 6. RS-485 RECEIVER ENABLE AND DISABLE TIMES

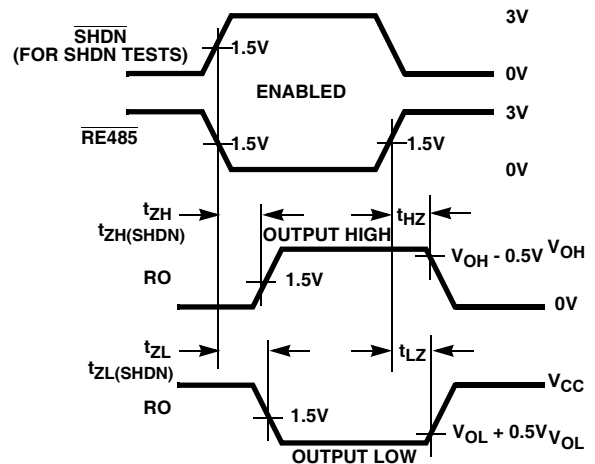

FIGURE 6B. MEASUREMENT POINTS

## Test Circuits and Waveforms (Continued)

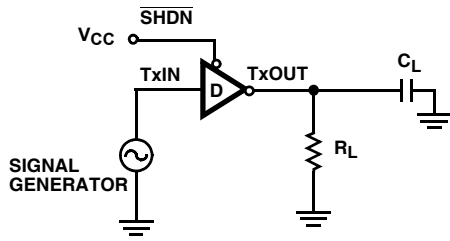

FIGURE 7A. TEST CIRCUIT

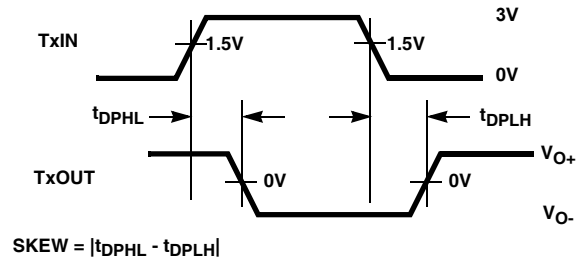

FIGURE 7B. MEASUREMENT POINTS

FIGURE 7. RS-232 DRIVER PROPAGATION DELAY AND TRANSITION TIMES

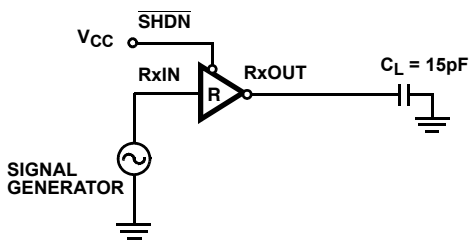

FIGURE 8A. TEST CIRCUIT

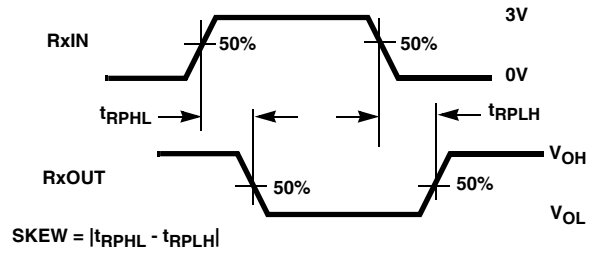

FIGURE 8B. MEASUREMENT POINTS

FIGURE 8. RS-232 RECEIVER PROPAGATION DELAY AND TRANSITION TIMES

# Typical Performance Curves $V_{CC} = 3.3V, T_A = +25^\circ C$ , unless otherwise specified

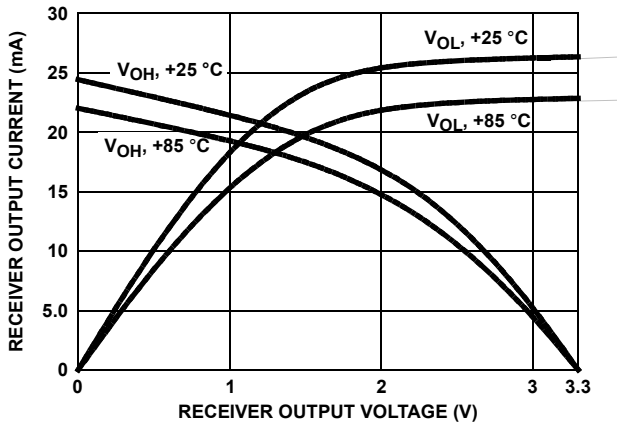

FIGURE 9. RECEIVER OUTPUT CURRENT vs RECEIVER OUTPUT VOLTAGE

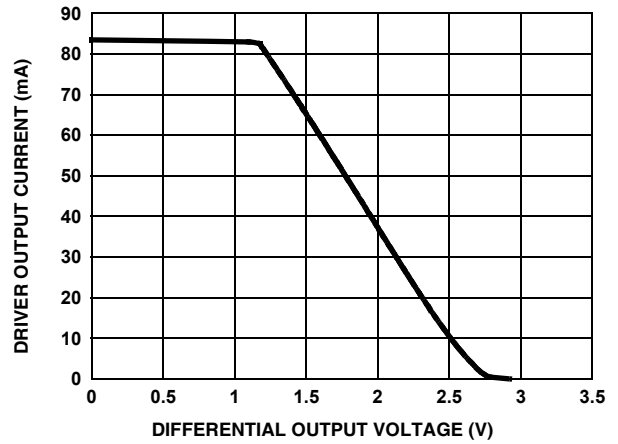

FIGURE 10. RS-485, DRIVER OUTPUT CURRENT vs DIFFERENTIAL OUTPUT VOLTAGE

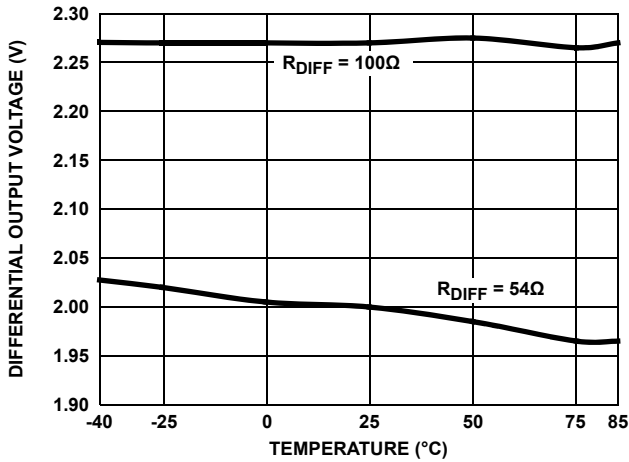

FIGURE 11. RS-485, DRIVER DIFFERENTIAL OUTPUT VOLTAGE vs TEMPERATURE

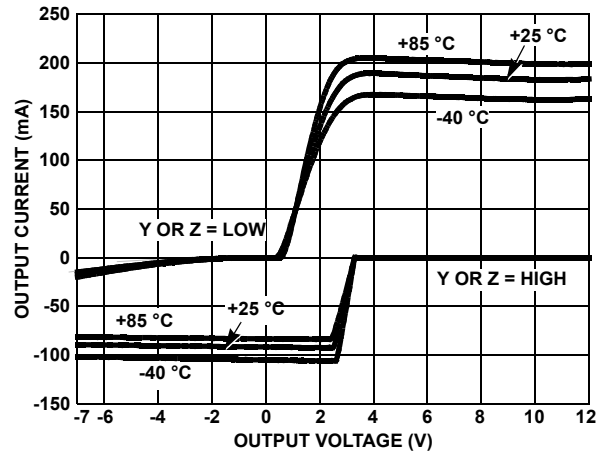

FIGURE 12. RS-485, DRIVER OUTPUT CURRENT vs SHORT-CIRCUIT VOLTAGE

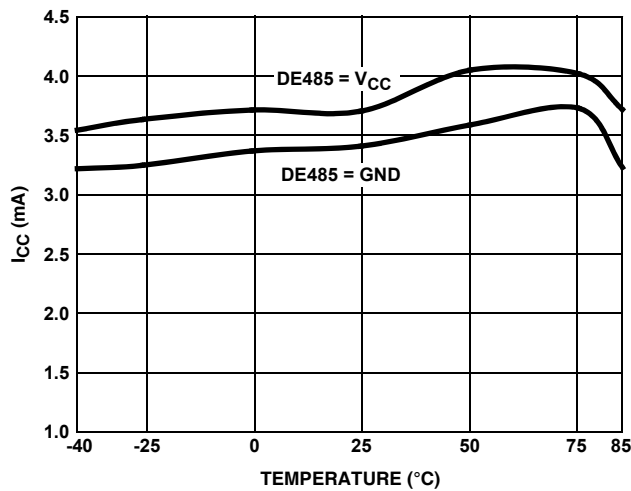

FIGURE 13. SUPPLY CURRENT vs TEMPERATURE

**Typical Performance Curves**  $V_{CC} = 3.3V, T_A = +25^\circ C$ , unless otherwise specified (Continued)

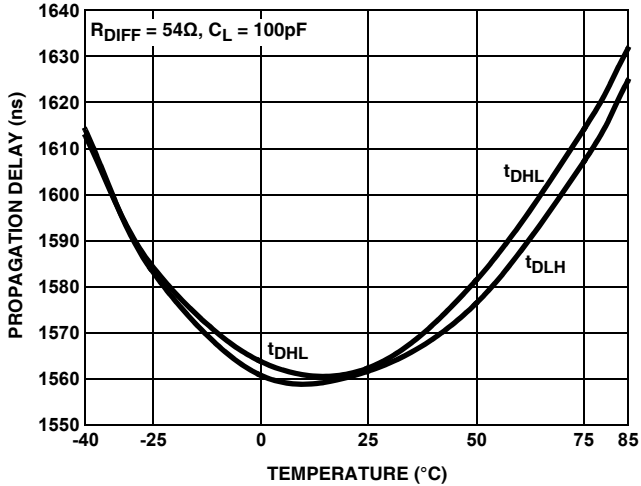

FIGURE 14. RS-485, DRIVER PROPAGATION DELAY vs TEMPERATURE (SLOW DATA RATE)

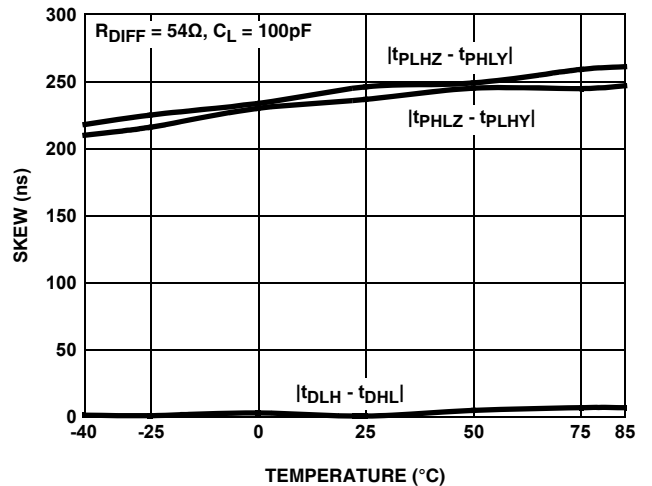

FIGURE 15. RS-485, DRIVER SKEW vs TEMPERATURE (SLOW DATA RATE)

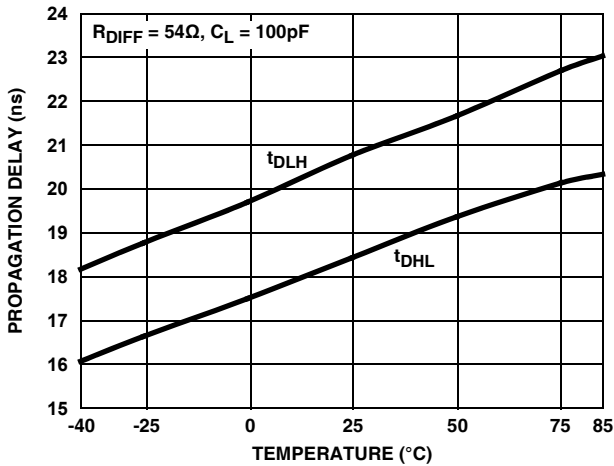

FIGURE 16. RS-485, DRIVER PROPAGATION DELAY vs TEMPERATURE (FAST DATA RATE)

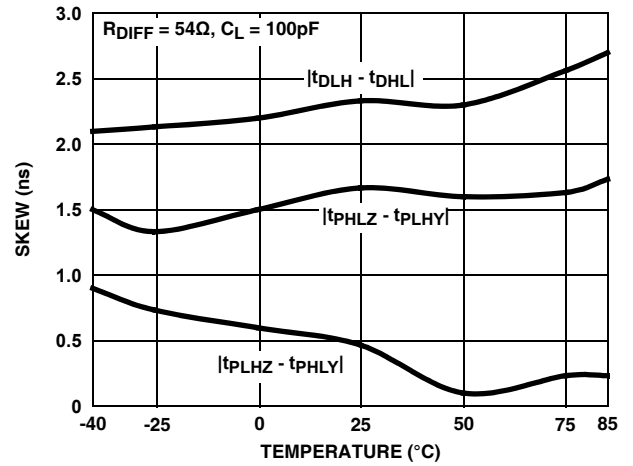

FIGURE 17. RS-485, DRIVER SKEW vs TEMPERATURE (FAST DATA RATE)

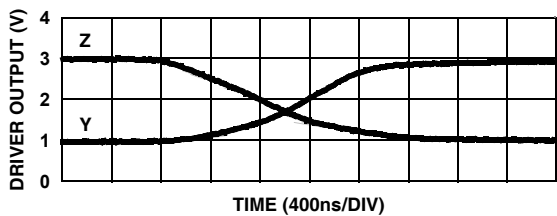
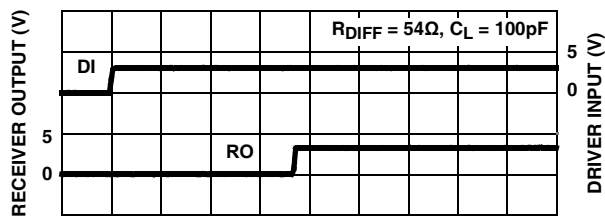

FIGURE 18. RS-485, DRIVER AND RECEIVER WAVEFORMS, LOW TO HIGH (SLOW DATA RATE)

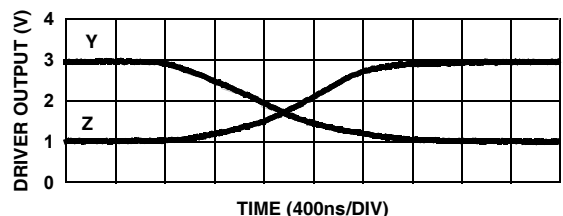
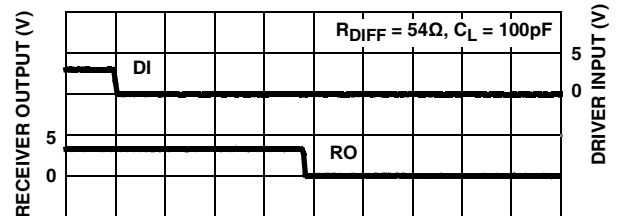

FIGURE 19. RS-485, DRIVER AND RECEIVER WAVEFORMS, HIGH TO LOW (SLOW DATA RATE)

# Typical Performance Curves $V_{CC} = 3.3V, T_A = +25^\circ C$ , unless otherwise specified (Continued)

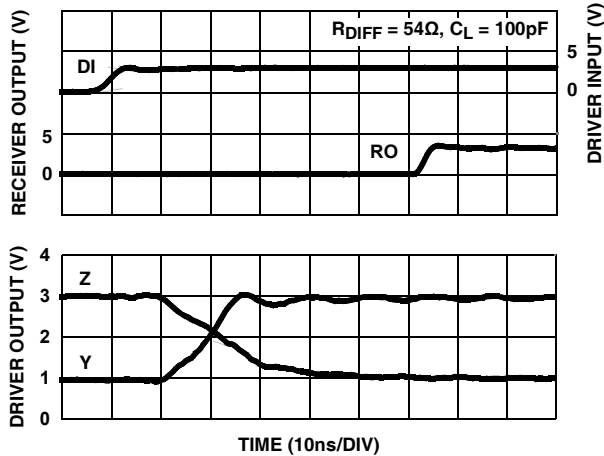

FIGURE 20. RS-485, DRIVER AND RECEIVER WAVEFORMS, LOW TO HIGH (FAST DATA RATE)

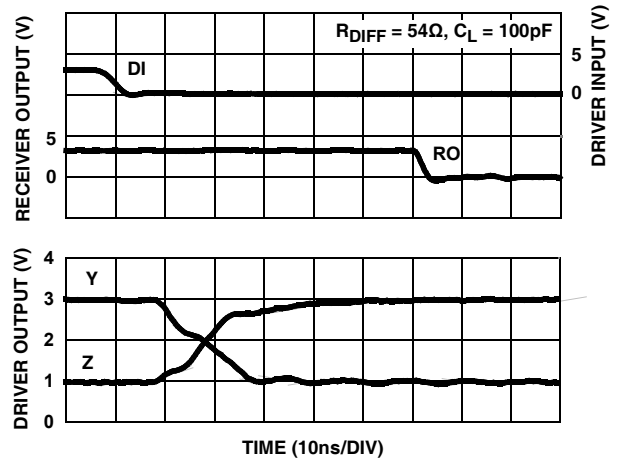

FIGURE 21. RS-485, DRIVER AND RECEIVER WAVEFORMS, HIGH TO LOW (FAST DATA RATE)

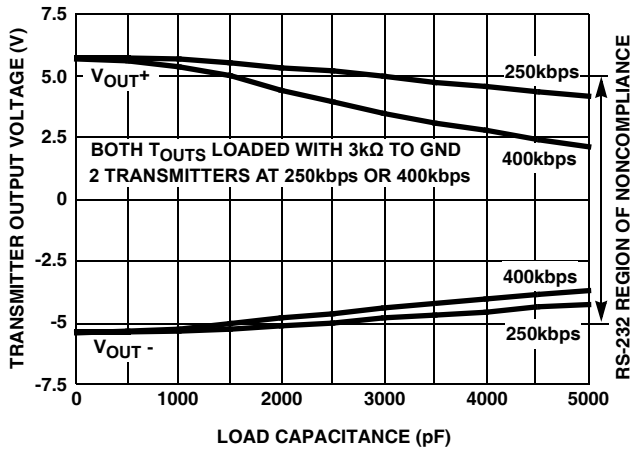

FIGURE 22. RS-232, TRANSMITTER OUTPUT VOLTAGE vs LOAD CAPACITANCE

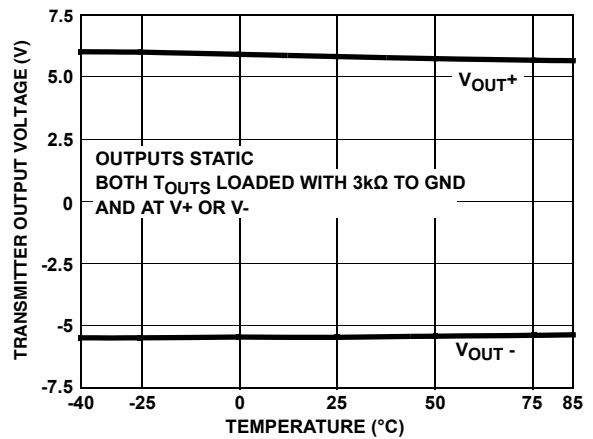

FIGURE 23. RS-232, TRANSMITTER OUTPUT VOLTAGE vs TEMPERATURE

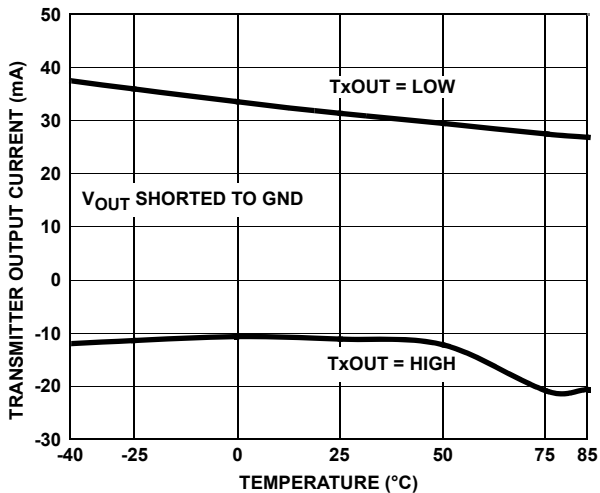

FIGURE 24. RS-232, TRANSMITTER SHORT-CIRCUIT CURRENT vs TEMPERATURE

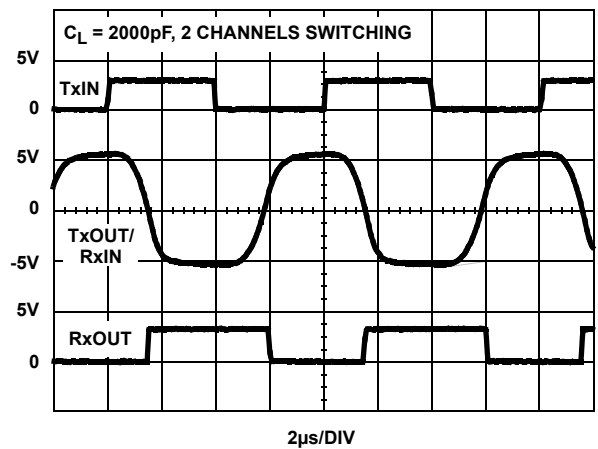

FIGURE 25. RS-232, TRANSMITTER AND RECEIVER WAVEFORMS AT 250kbps

**Typical Performance Curves**  $V_{CC} = 3.3V$ ,  $T_A = +25^\circ C$ , unless otherwise specified (Continued)

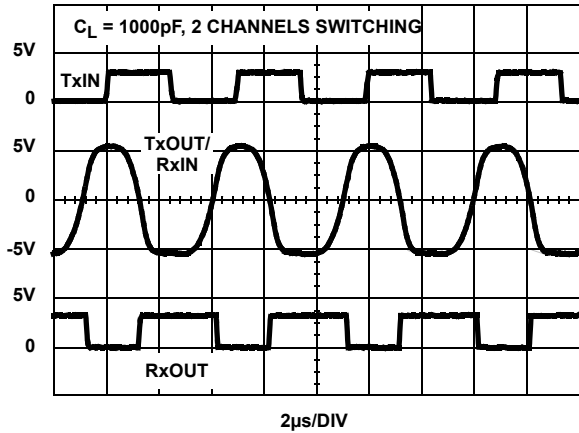

FIGURE 26. RS-232, TRANSMITTER AND RECEIVER WAVEFORMS AT 400kbps

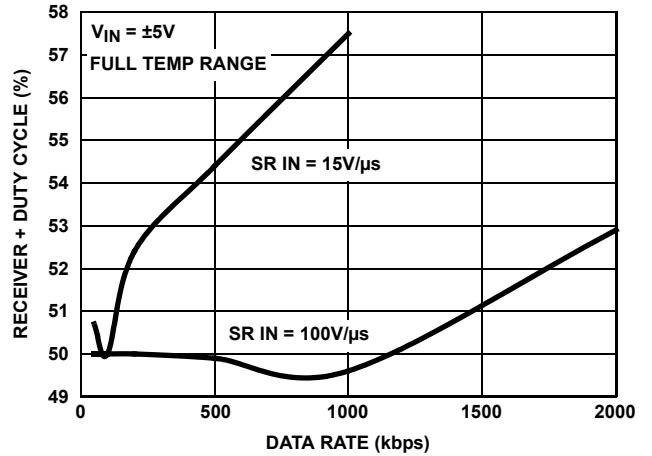

FIGURE 27. RS-232, RECEIVER OUTPUT + DUTY CYCLE vs DATA RATE

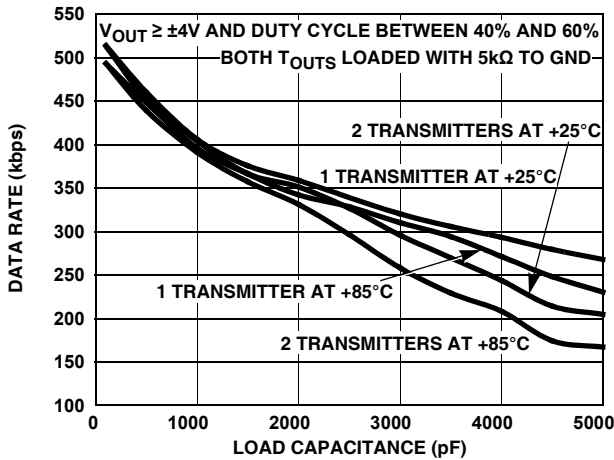

FIGURE 28. RS-232, TRANSMITTER MAXIMUM DATA RATE vs LOAD CAPACITANCE

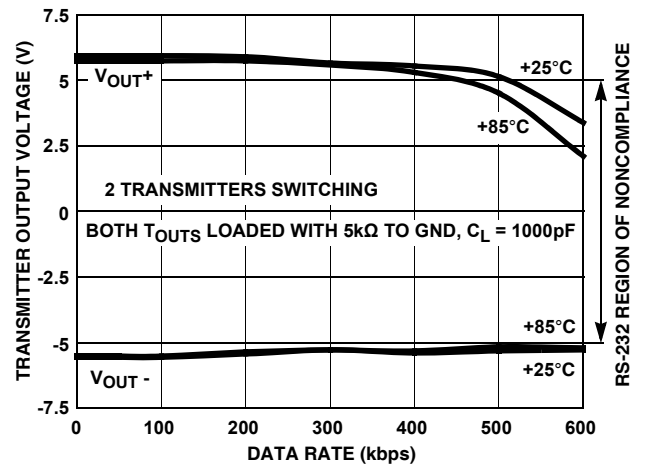

FIGURE 29. RS-232, TRANSMITTER OUTPUT VOLTAGE vs DATA RATE

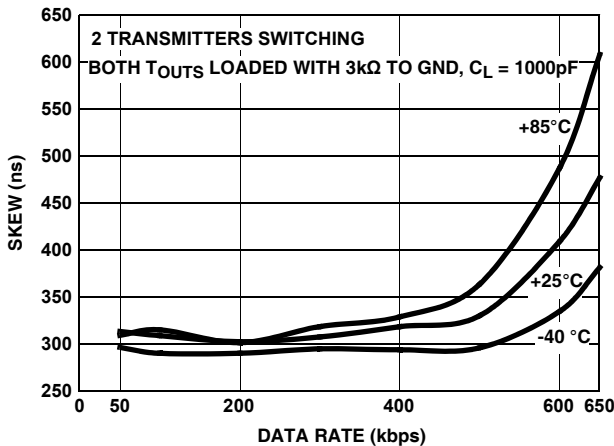

FIGURE 30. RS-232, TRANSMITTER SKEW vs DATA RATE

**Die Characteristics**

**SUBSTRATE AND QFN PAD POTENTIAL (POWERED UP):**

GND

**PROCESS:**

BiCMOS

## Typical Application

### RS-232 to RS-485 Converter

The ISL33334E, ISL33337E are ideal for implementing a single IC 2-wire (Tx Data, Rx Data) protocol converter, because each port is programmed for a different protocol. [Figure 31](#) illustrates the simple connections to create a single transceiver RS-232 to RS-485 converter. Depending on the RS-232 data rate, using an RS-422 bus as an RS-232 “extension cord” can extend the transmission distance up to 4000’ (1220m). A similar circuit on the other end of the cable completes the conversion to/from RS-232.

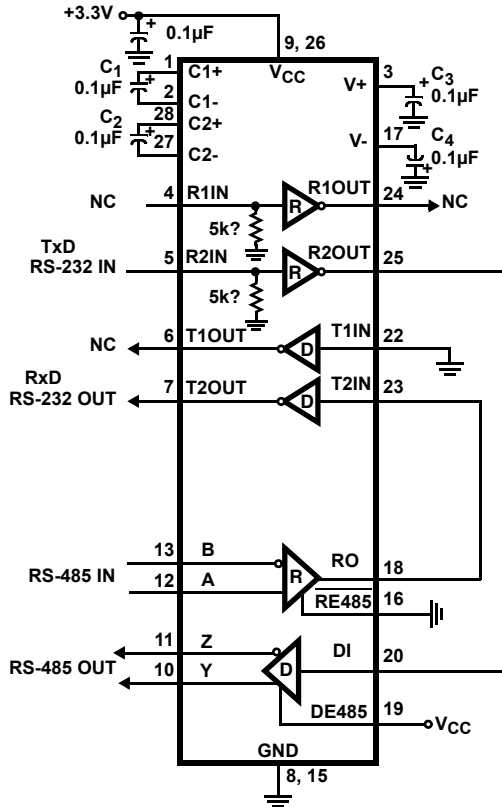

NOTE: PINOUT FOR SSOP

FIGURE 31. SINGLE IC RS-232 TO RS-485 CONVERTER

## Detailed Description

Each of the ISL3333XE parts supports dual protocols: RS-485/RS-422 (port 2) and RS-232 (port 1). RS-485 and RS-422 are differential (balanced) data transmission standards for use in high speed (up to 20Mbps) networks, or long haul and noisy environments. The differential signaling, coupled with RS-485’s requirement for an extended Common-mode Range (CMR) of +12V to -7V make these transceivers extremely tolerant of ground potential differences, as well as voltages induced in the cable by external fields. Both of these effects are real concerns when communicating over the RS-485/RS-422 maximum distance of 4000’ (1220m).

RS-422 is typically a point-to-point (one driver talking to one receiver on a bus), or a point-to-multiple receiver (multidrop) standard that allows only one driver and up to 10 receivers on each bus. Because of the one driver per bus limitation, RS-422 networks use a two bus, full duplex structure for bidirectional communication and the Rx inputs and Tx outputs (no tri-state required) connect to different busses, as shown in [Figure 33](#).

Conversely, RS-485 is a true multipoint standard, which allows up to 32 devices (any combination of drivers - must be tri-statable - and receivers) on each bus. Now, bidirectional communication takes place on a single bus, so the Rx inputs and Tx outputs of a port connect to the same bus lines, as shown in [Figure 32](#). Port 2 is set to RS-485 /RS-422 mode and includes one Rx and one Tx.

RS-232 is a point-to-point, single ended (signal voltages referenced to GND) communication protocol targeting fairly short (<150’, 46m) and low data rate (<1Mbps) applications. Port 1 contains two RS-232 transceivers (2 Tx and 2 Rx).

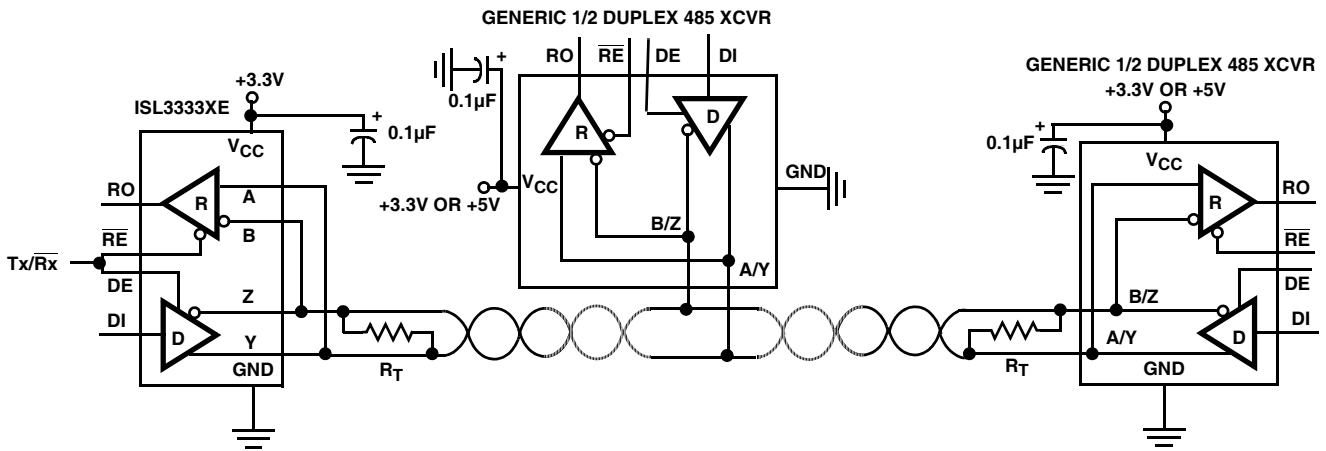

FIGURE 32. TYPICAL HALF DUPLEX RS-485 NETWORK

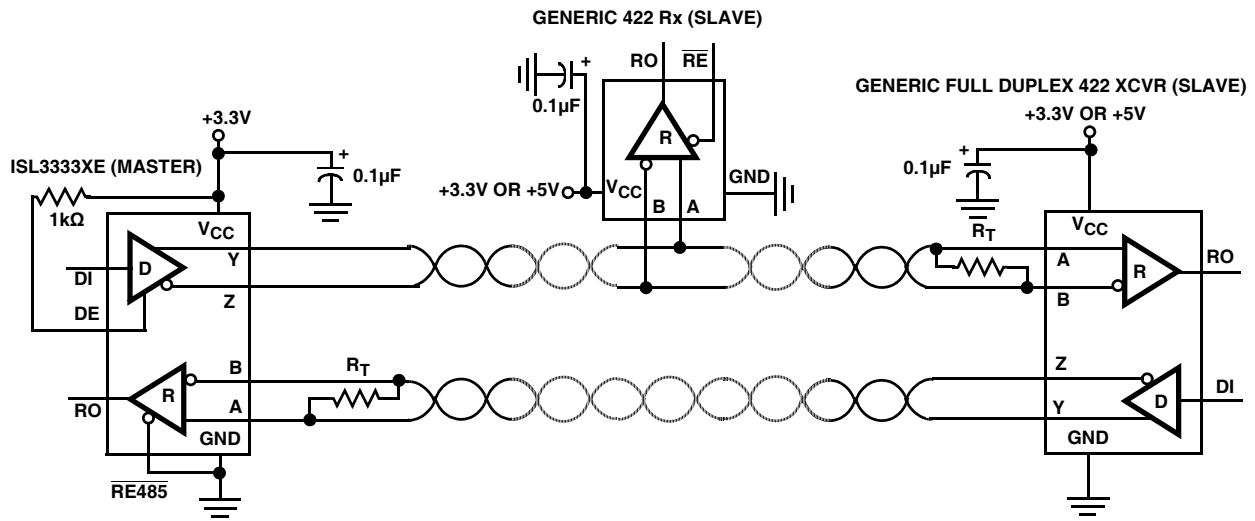

FIGURE 33. TYPICAL RS-422 NETWORK

## ISL3333XE Advantages

These dual protocol ICs offer many parametric improvements vs those offered on competing dual protocol devices. Some of the major improvements are:

- **3.3V Supply Voltage** - Eliminates the 5V supply that powers just the interface IC
- **15kV Bus Pin ESD** - Eases board level requirements
- **Full Fail-safe RS-485 Rx** - Eliminates bus biasing
- **Selectable RS-485 Data Rate** - Up to 20Mbps, or slew rate limited for low EMI and fewer termination issues
- **High RS-232 Data Rate** - >250kbps
- **Lower Tx and Rx Skews** - Wider, consistent bit widths
- **Lower I<sub>CC</sub>** - Max I<sub>CC</sub> is 2x to 4x lower than competition
- **Flow-Through Pinouts** - Tx, Rx bus pins on one side, logic pins on the other, for easy routing to connector/UART
- **Packaging** - Smaller (QFN) and Pb-free

## RS-232 Mode (Port 1)

### Rx Features

RS-232 receivers invert and convert RS-232 input levels ( $\pm 3V$  to  $\pm 25V$ ) to the standard TTL/CMOS levels required by a UART, ASIC, or  $\mu$ controller serial port. Receivers are designed to operate at faster data rates than the drivers and they feature very low skews (18ns) so the receivers contribute negligibly to bit width distortion. Inputs include the standards required 3k $\Omega$  to 7k $\Omega$  pull-down resistor, so unused inputs may be left unconnected. Rx inputs also have built-in hysteresis to increase noise immunity and to decrease erroneous triggering due to slowly transitioning input signals.

Rx outputs are short-circuit protected and are only tri-statable when the entire IC is shutdown via the  $\overline{\text{SHDN}}$  pin (see Table [Table 3 on page 3](#) and the “[Low Power Shutdown \(SHDN\) Mode](#)” on page 20 for more details).

### Tx Features

RS-232 drivers invert and convert the standard TTL/CMOS levels from a UART, or  $\mu$ controller serial port to RS-232 compliant levels ( $\pm 5V$  minimum). The Tx delivers these compliant output levels even at data rates of 400kbps, with loads of 500pF. The drivers are designed for low skew (typically 12% of the 400kbps bit width) and are compliant to the RS-232 slew rate spec (4 to 30V/ $\mu$ s) for a wide range of load capacitances. Tx inputs float if left unconnected and may cause I<sub>CC</sub> increases. For the best results, connect unused inputs to GND.

Tx outputs are short-circuit protected and incorporate a thermal shutdown feature to protect the IC in situations of severe power dissipation - see the RS-485 “[Tx Features](#)” on [page 19](#) for more details. Both Tx outputs disable when the IC enters thermal shutdown.

Drivers also tri-state in SHDN mode ( $\overline{\text{SHDN}} = 0$ ), or when the 3.3V power supply is off (see [Table 3](#) and the “[Low Power Shutdown \(SHDN\) Mode](#)” on [page 20](#) section for more details).

SHDN is a global function - affecting both ports - so it is useful for disabling the RS-232 outputs only if both ports will always be disabled together and if it is acceptable for the Rx to be disabled as well.

### Charge Pumps

The on-chip charge pumps create the RS-232 transmitter power supplies (typically +5.7/-5.3V) from a single supply as low as 3.15V and are enabled all the time unless in SHDN via the  $\overline{\text{SHDN}}$  pin. The efficient design requires only four small 0.1 $\mu$ F capacitors for the voltage doubler and inverter functions. By operating discontinuously (i.e., turning off as soon as V+ and V- pump up to the nominal values), the charge pump contribution to I<sub>CC</sub> reduces significantly.

### Data Rates and Cabling

Drivers operate at data rates up to 400kbps and are guaranteed for data rates up to 250kbps. The charge pumps and drivers are designed such that both drivers in port 1 can be operated at the rated load and at 250kbps (see [Figure 22 on page 14](#)). [Figure 22](#) also shows that drivers can easily two thousand picofarads at data rates up to 250kbps, while still delivering compliant  $\pm 5V$  output levels.

Receivers operate at data rates up to 2Mbps. They are designed for a higher data rate to facilitate faster factory downloading of software into the final product, thereby improving the user's manufacturing throughput.

[Figures 25](#) and [26](#) illustrate driver and receiver waveforms at 250kbps and 400kbps, respectively. For these graphs, both drivers of port 1 drive the specified capacitive load and a receiver in the port.

RS-232 doesn't require anything special for cabling; just a single bus wire per transmitter and receiver and another wire for GND. So an ISL3333XE RS-232 port uses a five conductor cable for interconnection. Bus terminations are not required, nor allowed, by the RS-232 standard.

## RS-485 Mode (Port 2)

### Rx Features

RS-485 receivers convert differential input signals as small as 200mV, as required by the RS-485 and RS-422 standards, to TTL/CMOS output levels. The differential Rx provides maximum sensitivity, noise immunity and common-mode rejection. Per the RS-485 standard, receiver inputs function with common-mode voltages from +12V to -7V, regardless of supply voltage, making them ideal for long networks where induced voltages are a realistic concern. The RS-485/RS-422 port includes a single receiver (RO).

Worst case receiver input currents are 20% lower than the 1 “unit load” (1mA) RS-485 limit, which translates to a 15k $\Omega$  minimum input resistance.

This receiver includes a “full fail-safe” function that guarantees a high level receiver output if the receiver inputs are unconnected (floating), shorted together, or if the bus is terminated but undriven (i.e., differential voltage collapses to near zero due to termination). Fail-safe with shorted, or

terminated and undriven inputs is accomplished by setting the Rx upper switching point at -40mV, thereby ensuring that the Rx recognizes a 0V differential as a high level.

The Rx output is short-circuit protected and is tri-stated when the  $\overline{RE485}$  input is driven low or when the IC is forced into SHDN via a logic low on the SHDN pin.

## Tx Features

The RS-485/RS-422 driver is a differential output device that delivers at least 1.5V across a 54 $\Omega$  load (RS-485) and at least 2V across a 100 $\Omega$  load (RS-422). The drivers feature low propagation delay skew to maximize bit widths and to minimize EMI.

To allow multiple drivers on a bus, the RS-485 spec requires that drivers survive worst case bus contentions undamaged. The ISL3333XE drivers meet this requirement via driver output short-circuit current limits and on-chip thermal shutdown circuitry. The output stages incorporate current limiting circuitry that ensures that the output current never exceeds the RS-485 spec, even at the common-mode voltage range extremes of 12V and -7V. In the event of a major short-circuit condition, devices also include a thermal shutdown feature that disables the drivers whenever the die temperature becomes excessive. This eliminates the power dissipation, allowing the die to cool. The drivers automatically re-enable after the die temperature drops about 15 degrees. If the contention persists, the thermal shutdown/re-enable cycle repeats until the fault is cleared. Receivers stay operational during thermal shutdown.

RS-485 multidriver operation also requires drivers to include tri-state functionality, so port 2 has a DE485 pin to control this function. If the driver is used in an RS-422 network, such that driver tri-state isn't required, then the DE485 pin should be connected to  $V_{CC}$ , through a 1k $\Omega$  resistor, to keep the Tx in the enabled state. Drivers are also tri-stated when the IC is in SHDN, or when the 3.3V power supply is off.

## Speed Options

The ISL3333XE offer two RS-485 speed options selectable via the  $\overline{SLOW485}$  pin; "Fast" mode ( $\overline{SLOW485} = 1$ ) selects high slew rate driver outputs optimized for 20Mbps data rates while "Slow" mode uses slew rate limiting designed for 115kbps operation. See the "[RS-485 Slew Rate Limited Data Rates](#)" and "[Data Rate, Cables and Terminations](#)" sections for more information.

Receiver performance is the same for both speed options.

## RS-485 Slew Rate Limited Data Rates

These ICs allow the user to select fast Tx output transitions optimized for a 20Mbps data rate, or slew rate limited transitions optimized for a data rate of 115kbps. The 20Mbps fast edges may increase EMI and reflection issues, even though fast transitions aren't required at the lower data rates used by many applications. Choosing the slew limited edges for lower data rates permits longer unterminated networks, or longer stubs off terminated busses and helps minimize EMI and reflections.

Nevertheless, for the best jitter performance when driving long cables, the faster speed option may be preferable, even at lower data rates. The faster output transitions deliver less variability (jitter) when loaded with the large capacitance associated with long cables. Of course, faster transitions require more attention to ensuring short stub lengths and quality terminations, so there are trade-offs to be made. Assuming a jitter budget of 10%, it is likely better to go with the slow speed option for data rates of 115kbps or less, to minimize fast edge effects. For higher data rates, or when the absolute best jitter is required, use the high speed option. The data rate selection pertains to only port 2.

## Data Rate, Cables and Terminations

RS-485/RS-422 are intended for network lengths up to 4000' (1220m), but the maximum system data rate decreases as the transmission length increases. Devices operating at the maximum data rate of 20Mbps are limited to maximum lengths of 20-100' (6-31m), while devices operating at or below 115kbps can operate at the maximum length of 4000' (1220m).

Higher data rates require faster edges, so both of the ISL3333XE versions offer an edge rate capable of 20Mbps data rates. These ICs also offer a slew rate limited option to minimize problems at slower data rates. Nevertheless, for the best jitter performance when driving long cables, the faster speed settings may be preferable, even at low data rates. See the "[RS-485 Slew Rate Limited Data Rates](#)" section for details.

Twisted pair is the cable of choice for RS-485/RS-422 networks. Twisted pair cables tend to pick up noise and other electromagnetically induced voltages as common-mode signals, which are effectively rejected by the differential receivers in these ICs.

The preferred cable connection technique is "daisy-chaining", where the cable runs from the connector of one device directly to the connector of the next device, such that cable stub lengths are negligible. A "backbone" structure, where stubs run from the main backbone cable to each device's connector, is the next best choice, but care must be taken to ensure that each stub is electrically "short". See [Table 4](#) for recommended maximum stub lengths for each speed option.

TABLE 4. RECOMMENDED STUB LENGTHS

SPEED OPTION	MAXIMUM STUB LENGTH ft (m)
SLOW	350-500 (107-152)
FAST	1-3 (0.3 - 0.9)

Proper termination is imperative to minimize reflections when using the 20Mbps speed option. Short networks using the slow speed option need not be terminated, but terminations are recommended unless power dissipation is an overriding concern. Note that the RS-485 spec allows a maximum of two terminations on a network, otherwise the Tx output voltage may not meet the required  $V_{OD}$ .

In point-to-point, or point-to-multireceiver (RS-422) networks, the main cable should be terminated in its characteristic

impedance (typically 120Ω) at the end farthest from the driver. In multireceiver applications, stubs connecting receivers to the main cable should be kept as short as possible, but definitely shorter than the limits shown in Table 4. Multipoint (RS-485) systems require that the main cable be terminated in its characteristic impedance at both ends. Again, keep stubs connecting a transceiver to the main cable as short as possible and refer to Table 4. Avoid “star” and other configurations, where there are many “ends” which would require more than the two allowed terminations to prevent reflections.

### Active Low Rx Enable ( $\overline{\text{RE485}}$ )

In many RS-485 applications, especially half duplex configurations, users like to implement “echo suppression” by disabling the corresponding receiver while its driver is transmitting data. This function is available on the ISL3333XE parts via an active low  $\overline{\text{RE485}}$  pin for port 2. The active low function simplifies direction control, by allowing a single GPIO line to provide a Tx/Rx direction control signal. Figure 34 details the advantage of using the RE485 pin.

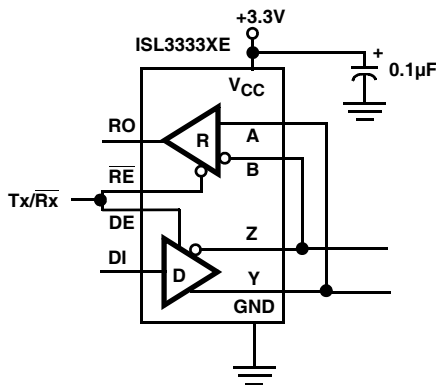

FIGURE 34. USING ACTIVE LOW RX ENABLE

## Additional Features

### High ESD

All pins on the ISL3333XE include ESD protection structures rated at  $\pm 2.5\text{kV}$  (HBM), which is good enough to survive ESD events commonly seen during manufacturing. But the bus pins (Tx outputs and Rx inputs) are particularly vulnerable to ESD events because they connect to an exposed port on the exterior of the finished product. Simply touching the port pins, or connecting a cable, can destroy an unprotected port. ISL3333XE bus pins are fitted with advanced structures that deliver ESD protection in excess of  $\pm 15\text{kV}$  (HBM), without interfering with any signal in the RS-485 or the RS-232 range. This high level of protection may eliminate the need for board level protection, or at the very least will increase the robustness of any board level scheme.

### Small Packages

Many competing dual protocol devices are only available in monstrously large 24 to 28 Ld SOIC packages. The ISL33334's 28 Ld SSOP is 50% smaller than even a 24 Ld SOIC and the ISL33337E's small 6x6mm QFN footprint is 80% smaller than a 28 Ld SOIC.

### Flow-Through Pinouts

Even the ISL3333XE pinouts are features, in that the **true** flow-through design simplifies board layout. Having the bus pins all on one side of the package for easy routing to a cable connector and the Rx outputs and Tx inputs (logic pins) on the other side for easy connection to a UART, avoids costly and problematic crossovers. Competing “flow-through” pinouts mix logic and bus pin inputs on one side of the package and logic and bus pin outputs on the other side. This forces the designer to route four traces from the right side of the IC around the IC to the cable connector. Figure 35 illustrates the flow-through nature of the ISL3333XE's pinout.

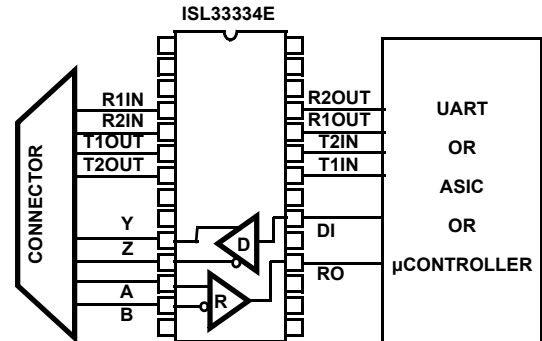

FIGURE 35. ILLUSTRATION OF FLOW-THROUGH PINOUT

### Low Power Shutdown (SHDN) Mode

The  $\overline{\text{SHDN}}$  pin is driven low to place the IC (both ports) in the SHDN mode and the already low supply current drops to as low as 40µA. If this functionality isn't desired, the  $\overline{\text{SHDN}}$  pin should be connected to  $V_{\text{CC}}$  through a 1kΩ resistor. SHDN disables the Tx and Rx outputs and disables the charge pumps, so  $V_{+}$  collapses to  $V_{\text{CC}}$  and  $V_{-}$  collapses to GND.

All but 10µA of SHDN supply current is due to control input (SHDN, SLOW485, DE485) pull-up resistors ( $\sim 10\mu\text{A}/\text{resistor}$  when the input = 0V), so SHDN supply current varies depending on the ISL3333XE configuration. For example, the RS-485 drivers are disabled in SHDN, so driving the DE485 pin high during this time reduces the SHDN supply current. The spec table indicates the SHDN  $I_{\text{CC}}$  for the worst case configuration.

When enabling from SHDN, allow at least 25µs for the charge pumps to stabilize before transmitting RS-232 data. The charge pumps aren't used by the RS-485 port, so the transceiver is ready to send or receive data in less than 2µs, which is much faster than competing devices that require the charge pump for all modes of operation.

**Revision History** The revision history provided is for informational purposes only and is believed to be accurate, but not warranted. Please visit our website to make sure you have the latest revision.

DATE	REVISION	CHANGE
October 21, 2016	FN8776.1	Added Related Literature section on page 1. Added Table 2 on page 2. Added Tape and Reel column to Ordering information table.
September 29, 2015	FN8776.0	Initial Release

## About Intersil

Intersil Corporation is a leading provider of innovative power management and precision analog solutions. The company's products address some of the largest markets within the industrial and infrastructure, mobile computing and high-end consumer markets.

For the most updated datasheet, application notes, related documentation and related parts, please see the respective product information page found at [www.intersil.com](http://www.intersil.com).

You may report errors or suggestions for improving this datasheet by visiting [www.intersil.com/ask](http://www.intersil.com/ask).

Reliability reports are also available from our website at [www.intersil.com/support](http://www.intersil.com/support).

© Copyright Intersil Americas LLC 2015-2016. All Rights Reserved.  
All trademarks and registered trademarks are the property of their respective owners.

For additional products, see [www.intersil.com/en/products.html](http://www.intersil.com/en/products.html)

Intersil products are manufactured, assembled and tested utilizing ISO9001 quality systems as noted in the quality certifications found at [www.intersil.com/en/support/qualandreliability.html](http://www.intersil.com/en/support/qualandreliability.html)

*Intersil products are sold by description only. Intersil may modify the circuit design and/or specifications of products at any time without notice, provided that such modification does not, in Intersil's sole judgment, affect the form, fit or function of the product. Accordingly, the reader is cautioned to verify that datasheets are current before placing orders. Information furnished by Intersil is believed to be accurate and reliable. However, no responsibility is assumed by Intersil or its subsidiaries for its use; nor for any infringements of patents or other rights of third parties which may result from its use. No license is granted by implication or otherwise under any patent or patent rights of Intersil or its subsidiaries.*

For information regarding Intersil Corporation and its products, see [www.intersil.com](http://www.intersil.com)

# Package Outline Drawing

For the most recent package outline drawing, see [L40.6x6](#).

## L40.6x6

40 LEAD QUAD FLAT NO-LEAD PLASTIC PACKAGE

Rev 3, 10/06

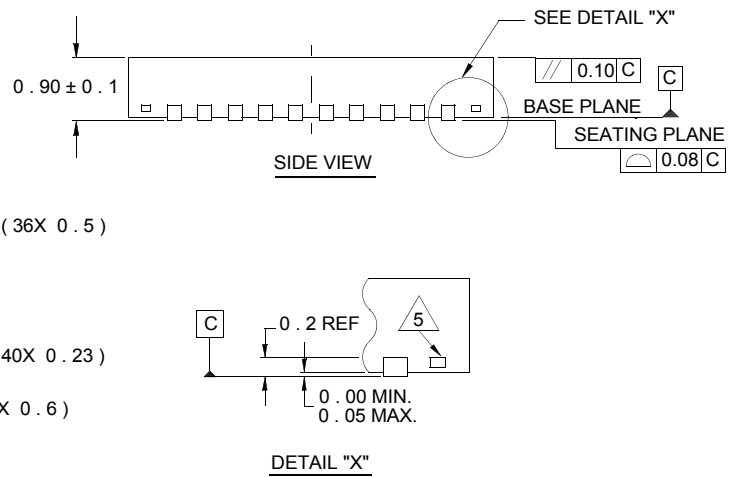
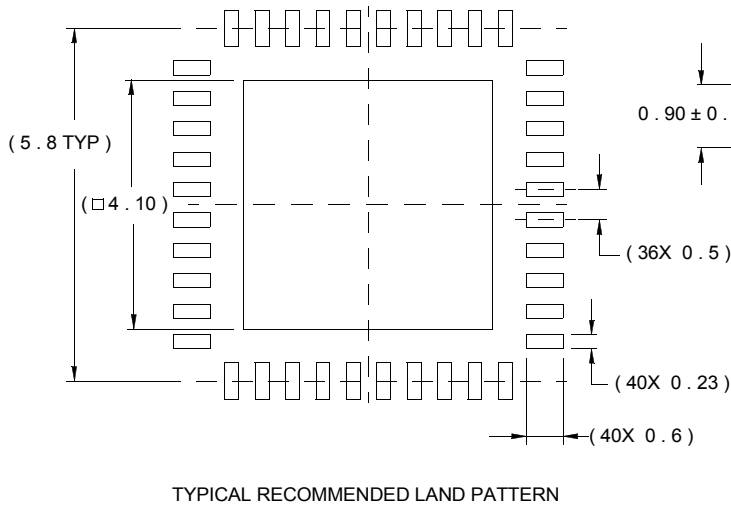
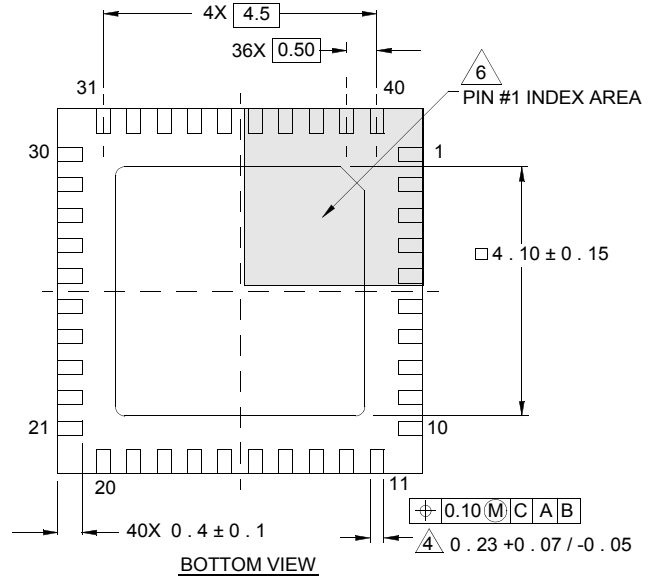
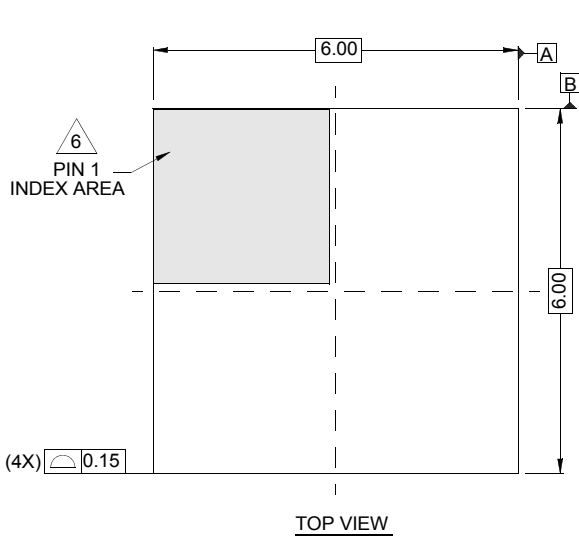

### NOTES:

- Dimensions are in millimeters.  
Dimensions in ( ) for Reference Only.
- Dimensioning and tolerancing conform to AMSE Y14.5m-1994.
- Unless otherwise specified, tolerance : Decimal  $\pm 0.05$
- Dimension b applies to the metallized terminal and is measured between 0.15mm and 0.30mm from the terminal tip.
- Tiebar shown (if present) is a non-functional feature.
- The configuration of the pin #1 identifier is optional, but must be located within the zone indicated. The pin #1 identifier may be either a mold or mark feature.

**Shrink Small Outline Plastic Packages (SSOP)**

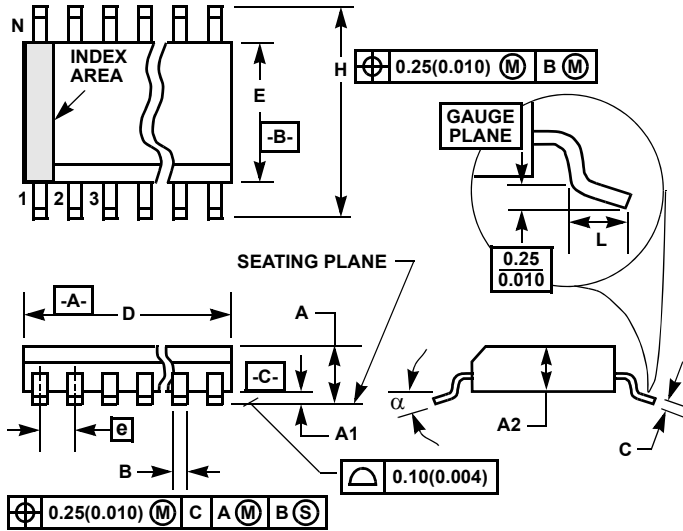

**M28.209 (JEDEC MO-150-AH ISSUE B)**  
**28 LEAD SHRINK SMALL OUTLINE PLASTIC PACKAGE**

SYMBOL	INCHES		MILLIMETERS		NOTES
	MIN	MAX	MIN	MAX	
A	-	0.078	-	2.00	-
A1	0.002	-	0.05	-	-
A2	0.065	0.072	1.65	1.85	-
B	0.009	0.014	0.22	0.38	9
C	0.004	0.009	0.09	0.25	-
D	0.390	0.413	9.90	10.50	3
E	0.197	0.220	5.00	5.60	4
e	0.026 BSC		0.65 BSC		-
H	0.292	0.322	7.40	8.20	-
L	0.022	0.037	0.55	0.95	6
N	28		28		7
$\alpha$	0°	8°	0°	8°	-

**NOTES:**

1. Symbols are defined in the "MO Series Symbol List" in Section 2.2 of Publication Number 95.
2. Dimensioning and tolerancing per ANSI Y14.5M-1982.
3. Dimension "D" does not include mold flash, protrusions or gate burrs. Mold flash, protrusion and gate burrs shall not exceed 0.20mm (0.0078 inch) per side.
4. Dimension "E" does not include interlead flash or protrusions. Interlead flash and protrusions shall not exceed 0.20mm (0.0078 inch) per side.
5. The chamfer on the body is optional. If it is not present, a visual index feature must be located within the crosshatched area.
6. "L" is the length of terminal for soldering to a substrate.
7. "N" is the number of terminal positions.
8. Terminal numbers are shown for reference only.
9. Dimension "B" does not include dambar protrusion. Allowable dambar protrusion shall be 0.13mm (0.005 inch) total in excess of "B" dimension at maximum material condition.
10. Controlling dimension: MILLIMETER. Converted inch dimensions are not necessarily exact.

Rev. 2 6/05

For the most recent package outline drawing, see [M28.209](#).

## Looking for pricing, stock, or lifecycle information?

Click below to explore more details on WIN SOURCE:

-  [View ISL33337EIRZ on WIN SOURCE](#)
-  [Renesas Electronics America](#) Information

## Optimize Your Supply Chain with WIN SOURCE Solutions

-  Global Sourcing Solution
-  Obsolete Management
-  Cost Control Management
-  Shortage Management
-  Alternative Solution
-  Excess Inventory Management