



**THE DATASHEET OF
LMZ31503RUQR**



LMZ31503 3-A Power Module With 4.5-V to 14.5-V Input in QFN Package

1 Features

- Complete Integrated Power Solution Allows Small Footprint, Low-Profile Design
- 9 mm × 15mm × 2.8mm package
- Pin Compatible with LMZ31506
- Efficiencies Up To 95%
- Wide-Output Voltage Adjust
0.8 V to 5.5 V, with 1% Reference Accuracy
- Optional Split Power Rail Allows Input Voltage Down to 1.6 V
- Adjustable Switching Frequency
(330 kHz to 780 kHz)
- Synchronizes to an External Clock
- Adjustable Slow-Start
- Output Voltage Sequencing / Tracking
- Power Good Output
- Programmable Undervoltage Lockout (UVLO)
- Overcurrent Protection (Hiccup-Mode)
- Over Temperature Protection
- Pre-bias Output Start-up
- Operating Temperature Range: -40°C to $+85^{\circ}\text{C}$
- Enhanced Thermal Performance: $13^{\circ}\text{C}/\text{W}$
- Meets EN55022 Class B Emissions
- Integrated Shielded Inductor
- Create a Custom Design Using the LMZ31503 With the [WEBENCH[®] Power Designer](#)

2 Applications

- Broadband & Communications Infrastructure
- Automated Test and Medical Equipment
- Compact PCI / PCI Express / PXI Express
- DSP and FPGA Point of Load Applications
- High Density Distributed Power Systems

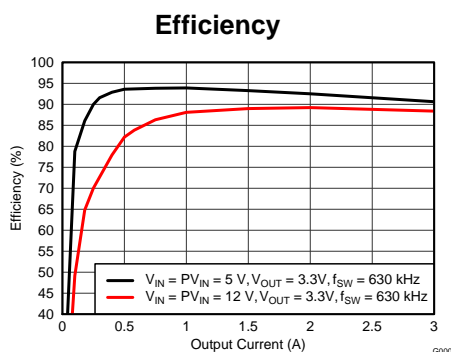

3 Description

The LMZ31503 power module is an easy-to-use integrated power solution that combines a 3-A DC/DC converter with power MOSFETs, a shielded inductor, and passes into a low profile, QFN package. This total power solution allows as few as 3 external components and eliminates the loop compensation and magnetics design process.

The $9 \times 15 \times 2.8$ mm QFN package is easy to solder onto a printed circuit board and allows a compact point-of-load design with up to 95% efficiency and excellent power dissipation with a thermal impedance of $13^{\circ}\text{C}/\text{W}$ junction to ambient. The device delivers the full 3-A rated output current at 85°C ambient temperature without airflow.

The LMZ31503 offers the flexibility and the feature-set of a discrete point-of-load design and is ideal for powering performance DSPs and FPGAs. Advanced packaging technology afford a robust and reliable power solution compatible with standard QFN mounting and testing techniques.

Simplified Schematic

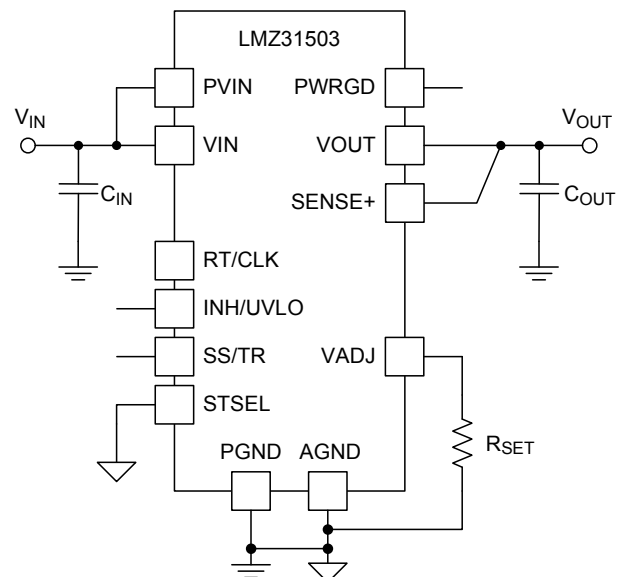

4 Specifications

4.1 Absolute Maximum Ratings⁽¹⁾

over operating temperature range (unless otherwise noted)

		VALUE	UNIT
Input Voltage	VIN	–0.3 to 16	V
	PVIN	–0.3 to 16	V
	INH/UVLO	–0.3 to 6	V
	VADJ	–0.3 to 3	V
	PWRGD	–0.3 to 6	V
	SS/TR	–0.3 to 3	V
	STSEL	–0.3 to 3	V
	RT/CLK	–0.3 to 6	V
Output Voltage	PH	–1 to 20	V
	PH 10ns Transient	–3 to 20	V
V _{DIFF} (GND to exposed thermal pad)		–0.2 to 0.2	V
Source Current	RT/CLK	±100	µA
	PH	Current Limit	A
Sink Current	PH	Current Limit	A
	PVIN	Current Limit	A
	PWRGD	–0.1 to 5	mA
Operating Junction Temperature		–40 to 125 ⁽²⁾	°C
Storage Temperature		–65 to 150	°C
Peak Reflow Case Temperature ⁽³⁾		245 ⁽⁴⁾	°C
Maximum Number of Reflows Allowed ⁽³⁾		3 ⁽⁴⁾	
Mechanical Shock	Mil-STD-883D, Method 2002.3, 1 msec, 1/2 sine, mounted	1500	G
Mechanical Vibration	Mil-STD-883D, Method 2007.2, 20-2000Hz	20	

- (1) Stresses beyond those listed under absolute maximum ratings may cause permanent damage to the device. These are stress ratings only, and functional operation of the device at these or any other conditions beyond those indicated under recommended operating conditions is not implied. Exposure to absolute-maximum-rated conditions for extended periods may affect device reliability.
- (2) See the temperature derating curves in the Typical Characteristics section for thermal information.
- (3) For soldering specifications, refer to the [Soldering Requirements for BQFN Packages](#) application note.
- (4) Devices with a date code prior to week 14 2018 (1814) have a peak reflow case temperature of 240°C with a maximum of one reflow

4.2 Thermal Information

THERMAL METRIC ⁽¹⁾		LMZ31503	UNIT
		RUQ47	
		47 PINS	
θ_{JA}	Junction-to-ambient thermal resistance ⁽²⁾	13	°C/W
Ψ_{JT}	Junction-to-top characterization parameter ⁽³⁾	2.5	°C/W
Ψ_{JB}	Junction-to-board characterization parameter ⁽⁴⁾	5	°C/W

- (1) For more information about traditional and new thermal metrics, see the [Semiconductor and IC Package Thermal Metrics](#) application report.
- (2) The junction-to-ambient thermal resistance, θ_{JA} , applies to devices soldered directly to a 100 mm x 100 mm double-sided PCB with 1 oz. copper and natural convection cooling. Additional airflow reduces θ_{JA} .
- (3) The junction-to-top characterization parameter, Ψ_{JT} , estimates the junction temperature, T_J , of a device in a real system, using a procedure described in JESD51-2A (sections 6 and 7). $T_J = \Psi_{JT} * P_{dis} + T_T$; where P_{dis} is the power dissipated in the device and T_T is the temperature of the top of the device.
- (4) The junction-to-board characterization parameter, Ψ_{JB} , estimates the junction temperature, T_J , of a device in a real system, using a procedure described in JESD51-2A (sections 6 and 7). $T_J = \Psi_{JB} * P_{dis} + T_B$; where P_{dis} is the power dissipated in the device and T_B is the temperature of the board 1mm from the device.

4.3 Package Specifications

LMZ31503		UNIT
Weight		1.26 grams
Flammability	Meets UL 94 V-O	
MTBF Calculated reliability	Per Bellcore TR-332, 50% stress, $T_A = 40^\circ\text{C}$, ground benign	40.1 Mhrs

4.4 Electrical Characteristics

Over -40°C to 85°C free-air temperature, $P_{VIN} = V_{IN} = 12\text{ V}$, $V_{OUT} = 1.8\text{ V}$, $I_{OUT} = 3\text{ A}$,

$C_{IN1} = 2 \times 22\ \mu\text{F}$ ceramic, $C_{IN2} = 68\ \mu\text{F}$ poly-tantalum, $C_{OUT1} = 4 \times 47\ \mu\text{F}$ ceramic (unless otherwise noted)

PARAMETER	TEST CONDITIONS	MIN	TYP	MAX	UNIT	
I_{OUT}	Output current	$T_A = 85^\circ\text{C}$, natural convection		0	3	A
V_{IN}	Input bias voltage range	Over I_{OUT} range		4.5	14.5	V
P_{VIN}	Input switching voltage range	Over I_{OUT} range		1.6 ⁽¹⁾	14.5	V
$UVLO$	V_{IN} Undervoltage lockout	$V_{IN} = \text{increasing}$		4.0	4.5	V
		$V_{IN} = \text{decreasing}$		3.5	3.85	
$V_{OUT(\text{adj})}$	Output voltage adjust range	Over I_{OUT} range		0.8	5.5	V
V_{OUT}	Set-point voltage tolerance	$T_A = 25^\circ\text{C}$, $I_{OUT} = 0\text{ A}$		$\pm 1.0\%$ ⁽²⁾		
	Temperature variation	$-40^\circ\text{C} \leq T_A \leq +85^\circ\text{C}$, $I_{OUT} = 0\text{ A}$		$\pm 0.3\%$		
	Line regulation	Over P_{VIN} range, $T_A = 25^\circ\text{C}$, $I_{OUT} = 0\text{ A}$		$\pm 0.1\%$		
	Load regulation	Over I_{OUT} range, $T_A = 25^\circ\text{C}$		$\pm 0.1\%$		
	Total output voltage variation	Includes set-point, line, load, and temperature variation		$\pm 1.5\%$ ⁽²⁾		
η	Efficiency	$P_{VIN} = V_{IN} = 12\text{ V}$ $I_O = 1.5\text{ A}$	$V_{OUT} = 5\text{ V}$, $f_{SW} = 780\text{ kHz}$	91.5 %		
			$V_{OUT} = 3.3\text{ V}$, $f_{SW} = 630\text{ kHz}$	89.0 %		
			$V_{OUT} = 2.5\text{ V}$, $f_{SW} = 480\text{ kHz}$	86.9 %		
			$V_{OUT} = 1.8\text{ V}$, $f_{SW} = 480\text{ kHz}$	85.2 %		
			$V_{OUT} = 1.2\text{ V}$, $f_{SW} = 480\text{ kHz}$	82.1 %		
			$V_{OUT} = 0.8\text{ V}$, $f_{SW} = 330\text{ kHz}$	78.7 %		
		$P_{VIN} = V_{IN} = 5\text{ V}$ $I_O = 1.5\text{ A}$	$V_{OUT} = 3.3\text{ V}$, $f_{SW} = 630\text{ kHz}$	93.3 %		
			$V_{OUT} = 2.5\text{ V}$, $f_{SW} = 480\text{ kHz}$	91.4 %		
			$V_{OUT} = 1.8\text{ V}$, $f_{SW} = 480\text{ kHz}$	88.8 %		
			$V_{OUT} = 1.2\text{ V}$, $f_{SW} = 480\text{ kHz}$	85.2 %		
$V_{OUT} = 0.8\text{ V}$, $f_{SW} = 330\text{ kHz}$	81.8 %					
	Output voltage ripple	20 MHz bandwidth		35	mV _{PP}	
I_{LIM}	Overcurrent threshold			5.8	A	

- (1) The minimum P_{VIN} voltage is 1.6V or $(V_{OUT} + 0.7\text{ V})$, whichever is greater. V_{IN} must be greater than 4.5V.
- (2) The stated limit of the set-point voltage tolerance includes the tolerance of both the internal voltage reference and the internal adjustment resistor. The overall output voltage tolerance will be affected by the tolerance of the external R_{SET} resistor.

Electrical Characteristics (continued)

Over -40°C to 85°C free-air temperature, $P_{VIN} = V_{IN} = 12\text{ V}$, $V_{OUT} = 1.8\text{ V}$, $I_{OUT} = 3\text{ A}$,
 $C_{IN1} = 2 \times 22\text{ }\mu\text{F}$ ceramic, $C_{IN2} = 68\text{ }\mu\text{F}$ poly-tantalum, $C_{OUT1} = 4 \times 47\text{ }\mu\text{F}$ ceramic (unless otherwise noted)

PARAMETER		TEST CONDITIONS	MIN	TYP	MAX	UNIT
Transient response	1.0 A/ μs load step from 50 to 100% $I_{OUT(max)}$	Recovery time		190		μs
		V_{OUT} over/undershoot		35		mV
V_{INH-H}	Inhibit Control	Inhibit High Voltage	1.30		Open ⁽³⁾	V
V_{INH-L}		Inhibit Low Voltage	-0.3		1.05	
	INH Input current	INH < 1.1 V		-1.15		μA
	INH Hysteresis current	INH > 1.26 V		-3.4		μA
$I_{I(stby)}$	Input standby current	INH pin to AGND		2	4	μA
Power Good	PWRGD Thresholds	V_{OUT} rising	Good	94%		
			Fault	109%		
		V_{OUT} falling	Fault	91%		
			Good	106%		
	PWRGD Low Voltage	$I(PWRGD) = 2\text{ mA}$			0.3	V
f_{SW}	Switching frequency	Over V_{IN} and I_{OUT} ranges, RT/CLK pin OPEN	270	330	390	kHz
f_{CLK}	Synchronization frequency	CLK Control	330		780	kHz
V_{CLK-H}	CLK High-Level Threshold		2.0		5.5	V
V_{CLK-L}	CLK Low-Level Threshold				0.8	V
D_{CLK}	CLK Duty cycle		20%		80%	
	Thermal Shutdown		Thermal shutdown	160	175	
		Thermal shutdown hysteresis		10		$^{\circ}\text{C}$
C_{IN}	External input capacitance	Ceramic	22 ⁽⁴⁾			μF
		Non-ceramic	68 ⁽⁴⁾			
C_{OUT}	External output capacitance	Ceramic	200 ⁽⁵⁾		1500	μF
		Non-ceramic			5000	
			Equivalent series resistance (ESR)			

- (3) This control pin has an internal pullup. If this pin is left open circuit, the device operates when input power is applied. A small low-leakage (<300 nA) MOSFET is recommended for control. See the application section for further guidance.
- (4) A minimum of 68 μF of polymer tantalum and/or ceramic external capacitance is required across the input (V_{IN} and PGND connected) for proper operation. Locate the capacitor close to the device. See [Table 5](#) for more details. When operating with split V_{IN} and P_{VIN} rails, place 4.7 μF of ceramic capacitance directly at the V_{IN} pin to PGND.
- (5) The amount of required output capacitance varies depending on the output voltage (see [Table 3](#)). The amount of required capacitance must include ceramic capacitance. Locate the capacitance close to the device. Adding additional capacitance close to the load improves the response of the regulator to load transients. See [Table 3](#) and [Table 5](#) more details.

5 Device Information

Functional Block Diagram

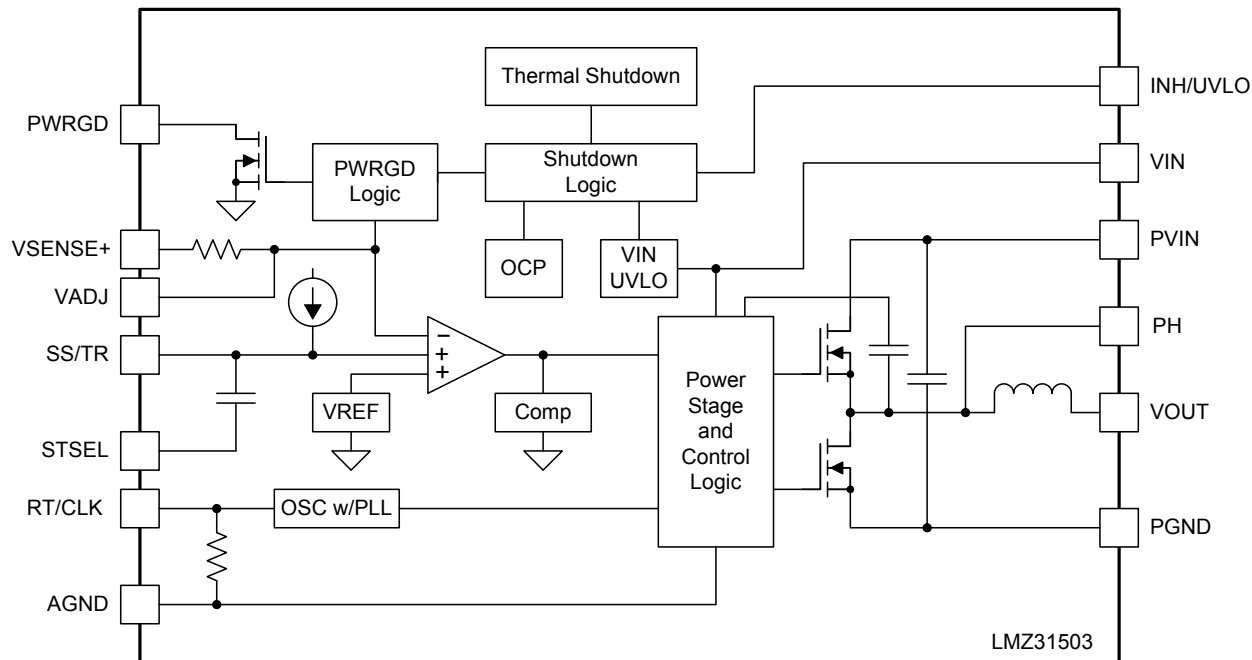

Pin Descriptions

TERMINAL		DESCRIPTION
NAME	NO.	
AGND	1	Zero VDC reference for the analog control circuitry. Connect AGND to PGND at a single point. Connect near the output capacitors. See for a recommended layout.
	2	
	34	
	45	
INH/UVLO	8	Inhibit and UVLO adjust pin. Use an open drain or open collector output logic to control the INH function. A resistor divider between this pin, AGND and VIN adjusts the UVLO voltage. Tie both pins together when using this control.
	9	
DNC	3	Do Not Connect. Do not connect these pins to AGND, to another DNC pin, or to any other voltage. These pins are connected to internal circuitry. Each pin must be soldered to an isolated pad.
	4	
	5	
	15	
	16	
	18	
	19	
	20	
	22	
	23	
	30	
	31	
32		
PGND	36	Common ground connection for the PVIN, VIN, and VOUT power connections. See for a recommended layout.
	37	
	38	
PH	10	Phase switch node. These pins should be connected to a small copper island under the device for thermal relief. Do not place any external component on this pin or tie it to a pin of another function.
	11	
	12	
	13	
	14	
	17	
46		
PWRGD	33	Power good fault pin. Asserts low if the output voltage is low. A pull-up resistor is required.
PVIN	39	Input switching voltage. This pin supplies voltage to the power switches of the converter. See for a recommended layout.
	40	
	41	
RT/CLK	35	This pin automatically selects between RT mode and CLK mode. An external timing resistor adjusts the switching frequency of the device. In CLK mode, the device synchronizes to an external clock.
SENSE+	44	Remote sense connection. Connect this pin to VOUT at the load for improved regulation. This pin must be connected to VOUT at the load, or at the module pins.
SS/TR	6	Slow-start and tracking pin. Connecting an external capacitor to this pin adjusts the output voltage rise time. A voltage applied to this pin allows for tracking and sequencing control.
STSEL	7	Slow-start or track feature select. Connect this pin to AGND to enable the internal SS capacitor with a SS interval of approximately 1.1 ms. Leave this pin open to enable the TR feature.
VADJ	43	Connecting a resistor between this pin and AGND sets the output voltage.
VIN	42	Input bias voltage pin. Supplies the control circuitry of the power converter. See for a recommended layout.

Pin Descriptions (continued)

TERMINAL		DESCRIPTION
NAME	NO.	
VOUT	21	Output voltage. Connect output capacitors between these pins and PGND.
	24	
	25	
	26	
	27	
	28	
	29	
	47	

**RUQ PACKAGE
47 PINS
(TOP VIEW)**

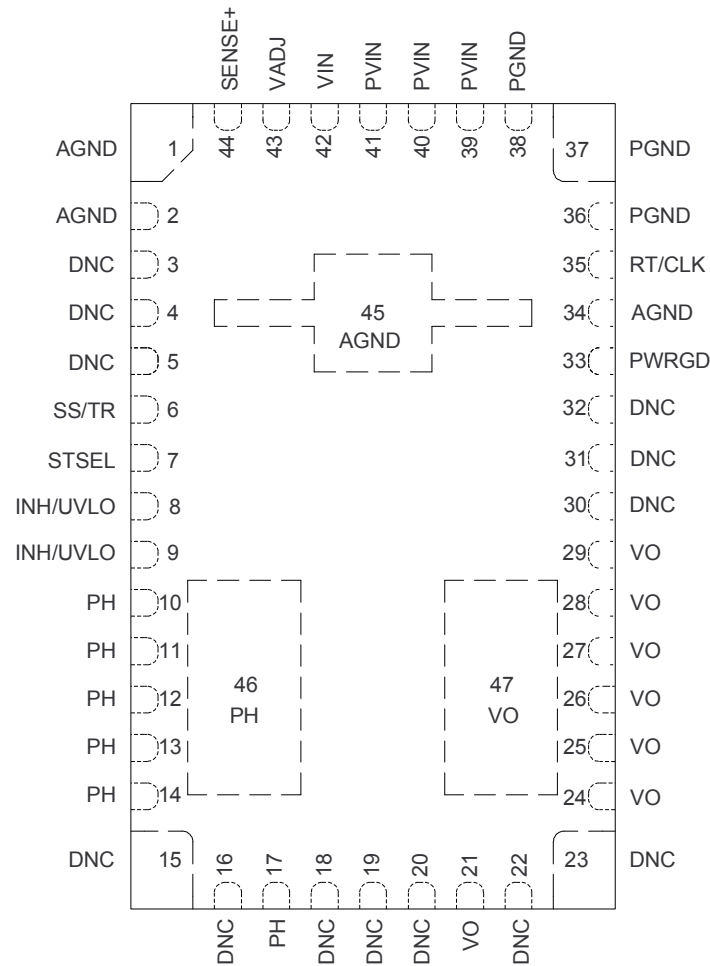

6 Typical Characteristics (P_{VIN} = V_{IN} = 12 V) ⁽¹⁾ ⁽²⁾

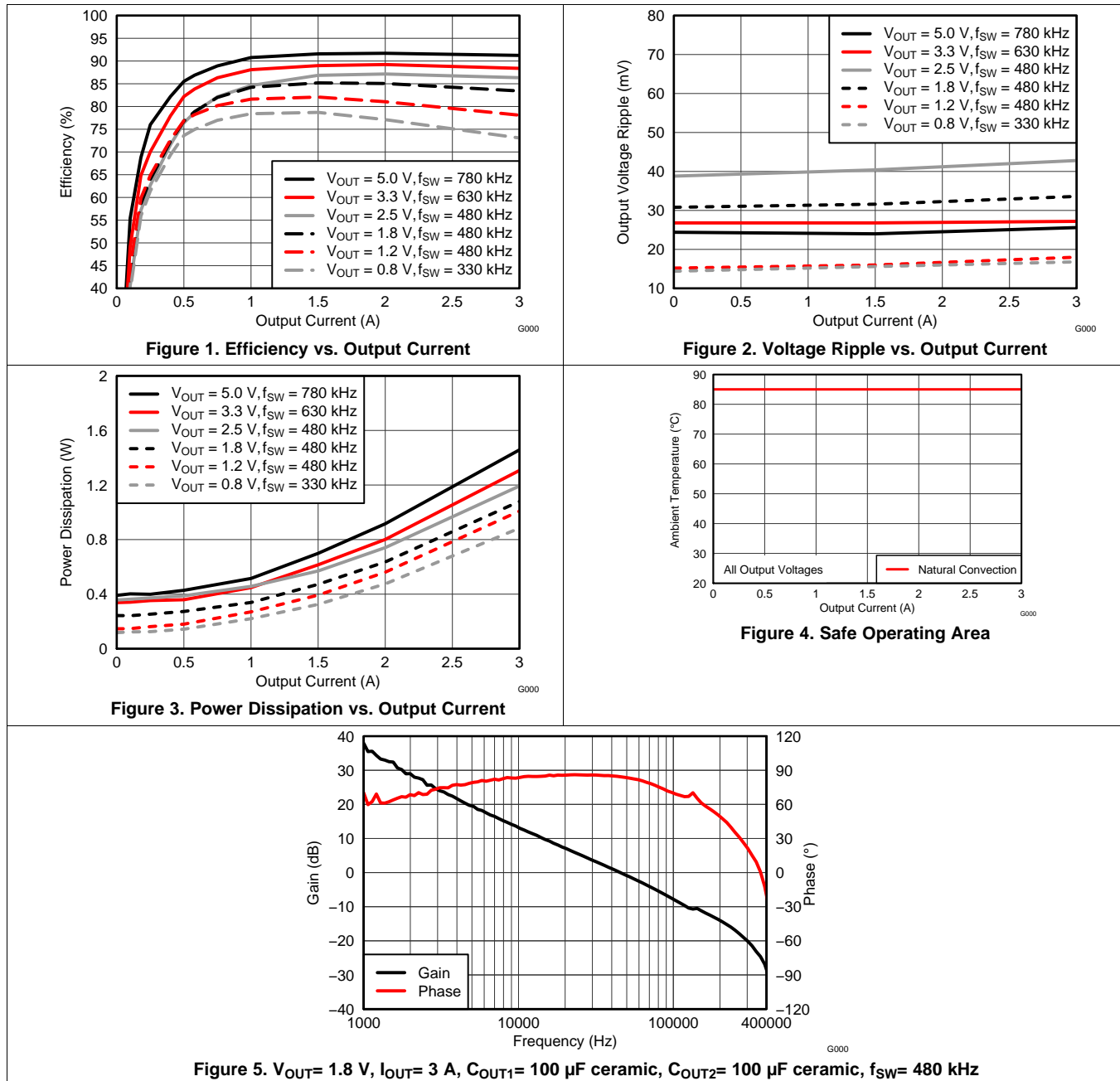

- (1) The electrical characteristic data has been developed from actual products tested at 25°C. This data is considered typical for the converter. Applies to [Figure 1](#), [Figure 2](#), and [Figure 3](#).
- (2) The temperature derating curves represent the conditions at which internal components are at or below the manufacturer's maximum operating temperatures. Derating limits apply to devices soldered directly to a 100 mm × 100 mm double-sided PCB with 1 oz. copper. Applies to [Figure 4](#).

7 Typical Characteristics (PVIN = VIN = 5 V) ⁽¹⁾ ⁽²⁾

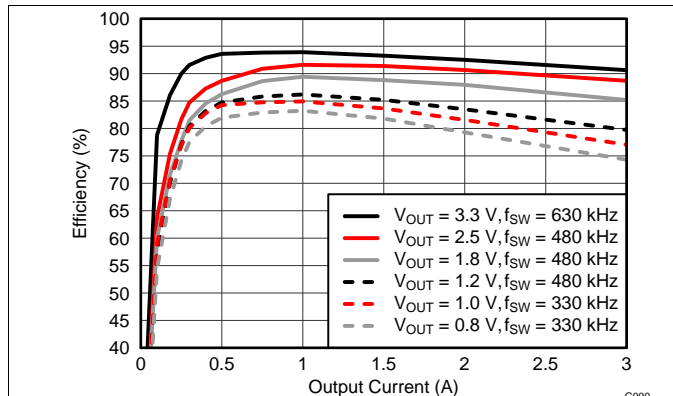

Figure 6. Efficiency vs. Output Current

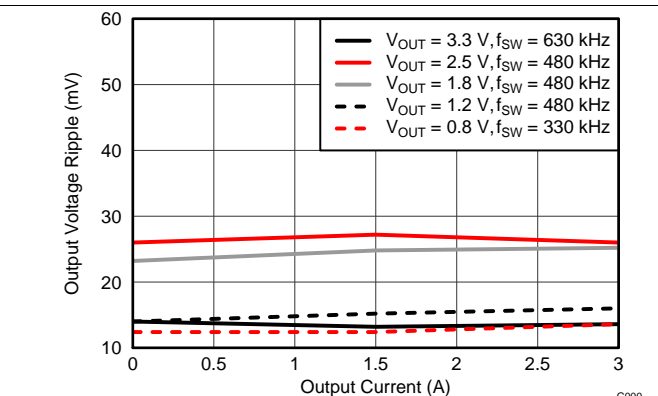

Figure 7. Voltage Ripple vs. Output Current

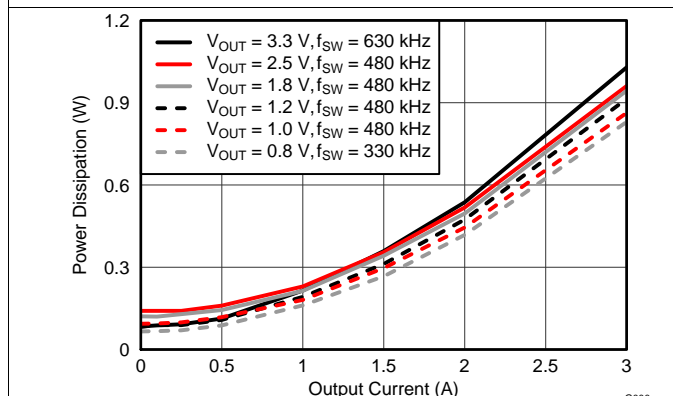

Figure 8. Power Dissipation vs. Output Current

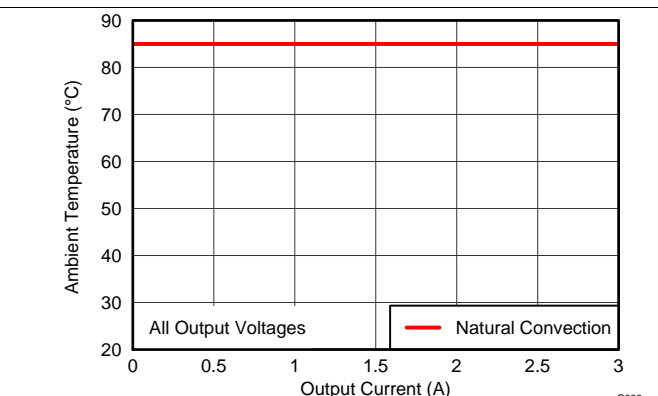

Figure 9. Safe Operating Area

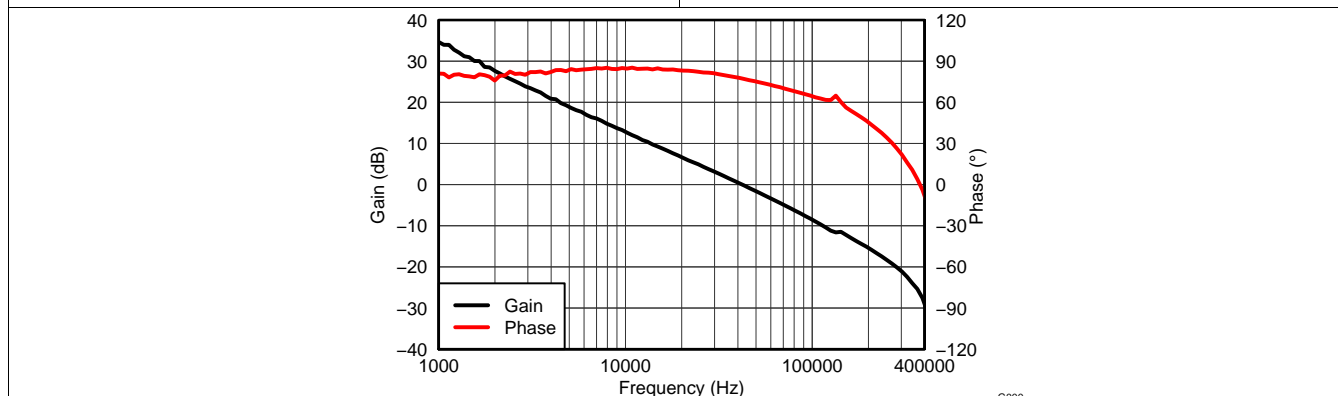
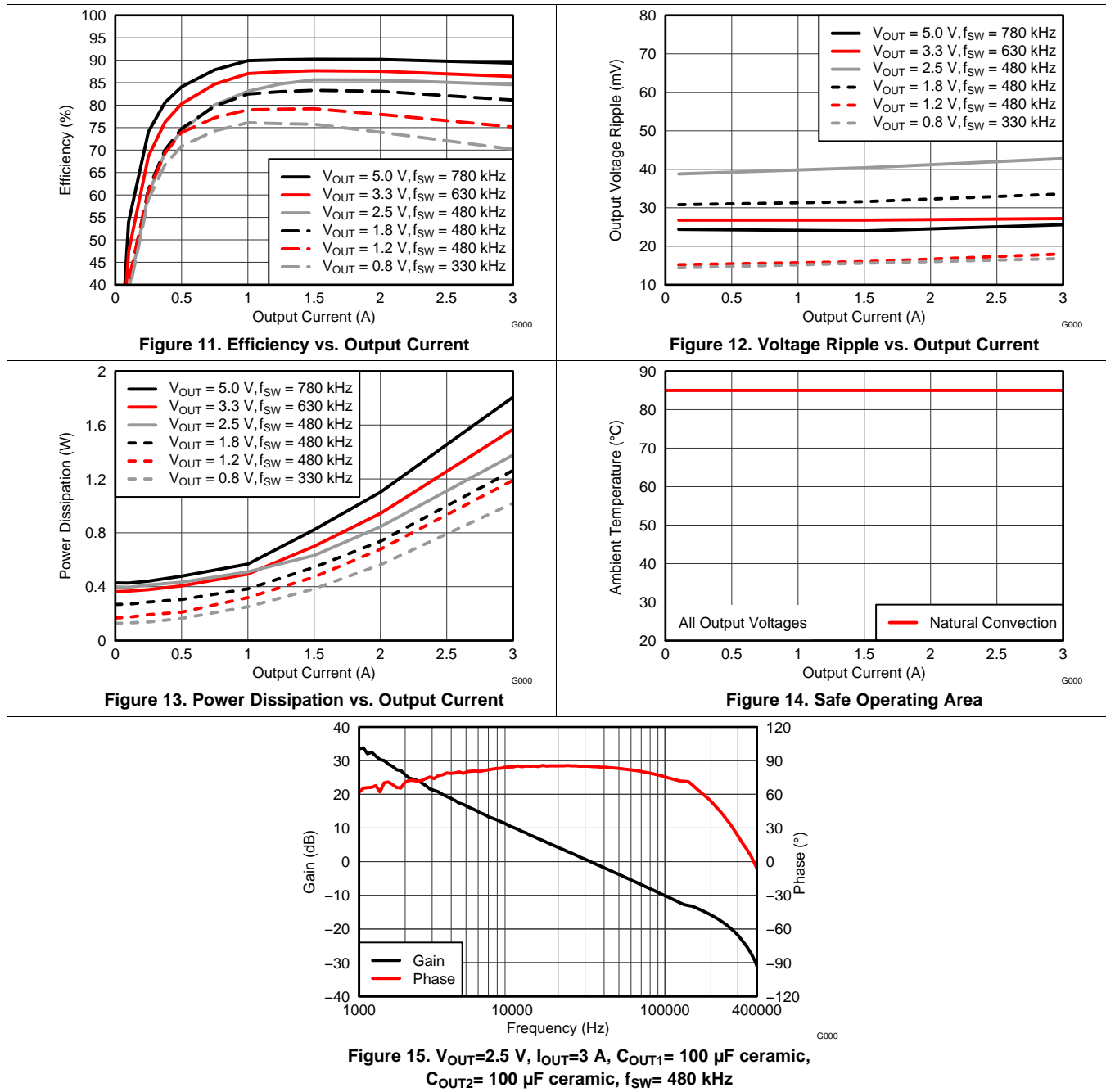

Figure 10. V_{OUT}=1.8 V, I_{OUT}=3 A, C_{OUT1}= 100 μF ceramic, C_{OUT2}= 100 μF ceramic, f_{SW}= 480 kHz

- (1) The electrical characteristic data has been developed from actual products tested at 25°C. This data is considered typical for the converter. Applies to [Figure 6](#), [Figure 7](#), and [Figure 8](#).
- (2) The temperature derating curves represent the conditions at which internal components are at or below the manufacturer's maximum operating temperatures. Derating limits apply to devices soldered directly to a 100 mm x 100 mm double-sided PCB with 1 oz. copper. Applies to [Figure 9](#).

8 Typical Characteristics (PVIN = 12 V, VIN = 5 V) ⁽¹⁾ ⁽²⁾



- (1) The electrical characteristic data has been developed from actual products tested at 25°C. This data is considered typical for the converter. Applies to [Figure 11](#), [Figure 12](#), and [Figure 13](#).
- (2) The temperature derating curves represent the conditions at which internal components are at or below the manufacturer's maximum operating temperatures. Derating limits apply to devices soldered directly to a 100 mm x 100 mm double-sided PCB with 1 oz. copper. Applies to [Figure 14](#).

9 Application Information

9.1 Adjusting the Output Voltage

The VADJ control sets the output voltage of the LMZ31503. The output voltage adjustment range is from 0.8V to 5.5V. The adjustment method requires the addition of R_{SET}, which sets the output voltage, the connection of SENSE+ to VOUT, and in some cases R_{RT} which sets the switching frequency. The R_{SET} resistor must be connected directly between the VADJ (pin 43) and AGND (pin 45). The SENSE+ pin (pin 44) must be connected to VOUT either at the load for improved regulation or at VOUT of the module. The R_{RT} resistor must be connected directly between the RT/CLK (pin 35) and AGND (pin 34).

Table 1 gives the standard external R_{SET} resistor for a number of common bus voltages, along with the required R_{RT} resistor for that output voltage. For other output voltages, the value of the required resistor can either be calculated using Equation 1, or selected from the values given in Table 2.

Table 1. Standard R_{SET} Resistor Values for Common Output Voltages

RESISTORS	OUTPUT VOLTAGE V _{OUT} (V)							
	0.8	1.0	1.2	1.5	1.8	2.5	3.3	5.0
R _{SET} (kΩ)	open	5.76	2.87	1.62	1.13	0.665	0.453	0.267
R _{RT} (kΩ)	open	open	324	324	324	324	158	105

$$R_{SET} = \frac{1.43}{\left(\left(\frac{V_{OUT}}{0.8}\right) - 1\right)} \text{ (k}\Omega\text{)} \quad (1)$$

Table 2. Standard R_{SET} Resistor Values

V _{OUT} (V)	R _{SET} (kΩ)	R _{RT} (kΩ)	f _{sw} (kHz)	V _{OUT} (V)	R _{SET} (kΩ)	R _{RT} (kΩ)	f _{sw} (kHz)
0.8	open	open	330	3.2	0.475	191	580
0.9	11.3	open	330	3.3	0.453	158	630
1.0	5.76	open	330	3.4	0.442	158	630
1.1	3.83	open	330	3.5	0.422	158	630
1.2	2.87	324	480	3.6	0.402	158	630
1.3	2.26	324	480	3.7	0.392	158	630
1.4	1.91	324	480	3.8	0.374	137	680
1.5	1.62	324	480	3.9	0.365	137	680
1.6	1.43	324	480	4.0	0.357	137	680
1.7	1.27	324	480	4.1	0.348	137	680
1.8	1.13	324	480	4.2	0.332	118	730
1.9	1.02	324	480	4.3	0.324	118	730
2.0	0.953	324	480	4.4	0.316	118	730
2.1	0.866	324	480	4.5	0.309	118	730
2.2	0.806	324	480	4.6	0.301	118	730
2.3	0.750	324	480	4.7	0.294	118	730
2.4	0.715	324	480	4.8	0.287	105	780
2.5	0.665	324	480	4.9	0.280	105	780
2.6	0.634	237	530	5.0	0.267	105	780
2.7	0.604	237	530	5.1	0.267	105	780
2.8	0.562	237	530	5.2	0.261	105	780
2.9	0.536	237	530	5.3	0.255	105	780
3.0	0.511	191	580	5.4	0.249	105	780
3.1	0.499	191	580	5.5	0.243	105	780

9.2 Capacitor Recommendations for the LMZ31503 Power Supply

9.2.1 Capacitor Technologies

9.2.1.1 Electrolytic, Polymer-Electrolytic Capacitors

When using electrolytic capacitors, high-quality, computer-grade electrolytic capacitors are recommended. Polymer-electrolytic type capacitors are recommended for applications where the ambient operating temperature is less than 0°C. The Sanyo OS-CON capacitor series is suggested due to the lower ESR, higher rated surge, power dissipation, ripple current capability, and small package size. Aluminum electrolytic capacitors provide adequate decoupling over the frequency range of 2 kHz to 150 kHz, and are suitable when ambient temperatures are above 0°C.

9.2.1.2 Ceramic Capacitors

The performance of aluminum electrolytic capacitors is less effective than ceramic capacitors above 150 kHz. Multilayer ceramic capacitors have a low ESR and a resonant frequency higher than the bandwidth of the regulator. They can be used to reduce the reflected ripple current at the input as well as improve the transient response of the output.

9.2.1.3 Tantalum, Polymer-Tantalum Capacitors

Polymer-tantalum type capacitors are recommended for applications where the ambient operating temperature is less than 0°C. The Sanyo POSCAP series and Kemet T530 capacitor series are recommended rather than many other tantalum types due to their lower ESR, higher rated surge, power dissipation, ripple current capability, and small package size. Tantalum capacitors that have no stated ESR or surge current rating are not recommended for power applications.

9.2.2 Input Capacitor

The LMZ31503 requires a minimum input capacitance of 68 μF of ceramic and/or polymer-tantalum capacitors. The ripple current rating of the capacitor must be at least 450 mArms. [Table 5](#) includes a preferred list of capacitors by vendor.

9.2.3 Output Capacitor

The required output capacitance is determined by the output voltage of the LMZ31503. See [Table 3](#) for the amount of required capacitance. The required output capacitance must be comprised of all ceramic capacitors. When adding additional non-ceramic bulk capacitors, low-ESR devices like the ones recommended in [Table 5](#) are required. The required capacitance above the minimum is determined by actual transient deviation requirements. See [Table 4](#) for typical transient response values for several output voltage, input voltage and capacitance combinations. [Table 5](#) includes a preferred list of capacitors by vendor.

Table 3. Required Output Capacitance

V_{OUT} RANGE (V)		MINIMUM REQUIRED C_{OUT} (μF)
MIN	MAX	
0.8	< 1.2	6x 47 μF ceramic
1.2	< 3.0	4x 47 μF ceramic
3.0	< 4.0	2x 47 μF ceramic
4.0	5.5	47 μF ceramic

Table 4. Output Voltage Transient Response

C _{IN1} = 22 µF CERAMIC, C _{IN2} = 68 µF POSCAP, LOAD STEP = 1.5 A, 1 A/µs						
V _{OUT} (V)	PV _{IN} (V)	C _{OUT1} Ceramic	C _{OUT2} BULK	VOLTAGE DEVIATION (mV)	PEAK-PEAK (mV)	RECOVERY TIME (µs)
0.8	5	6x 47 µF	None	25	55	170
		6x 47 µF	330 µF	15	30	160
	12	6x 47 µF	None	20	35	180
		6x 47 µF	330 µF	15	30	170
1.0	5	6x 47 µF	None	20	40	170
		6x 47 µF	330 µF	15	30	170
	12	6x 47 µF	None	20	45	180
		6x 47 µF	330 µF	15	30	170
1.2	5	4x 47 µF	None	30	55	170
		4x 47 µF	220 µF	25	45	170
	12	4x 47 µF	None	30	55	180
		4x 47 µF	220 µF	25	50	170
1.8	5	4x 47 µF	None	35	65	180
		4x 47 µF	220 µF	30	55	180
	12	4x 47 µF	None	35	65	190
		4x 47 µF	220 µF	30	55	180
3.3	5	2x 47 µF	None	65	130	190
		2x 47 µF	100 µF	55	110	190
	12	2x 47 µF	None	65	130	200
		2x 47 µF	100 µF	60	120	200
5.0	12	1x 47 µF	None	100	200	210
		1x 47 µF	100 µF	85	170	210

Table 5. Recommended Input/Output Capacitors⁽¹⁾

VENDOR	SERIES	PART NUMBER	CAPACITOR CHARACTERISTICS		
			WORKING VOLTAGE (V)	CAPACITANCE (µF)	ESR ⁽²⁾ (mΩ)
Murata	X5R	GRM32ER61E226K	16	22	2
TDK	X5R	C3225X5R0J476K	6.3	47	2
Murata	X5R	GRM32ER60J476M	6.3	47	2
Sanyo	POSCAP	16TQC68M	16	68	50
Kemet	T520	T520V107M010ASE025	10	100	25
Sanyo	POSCAP	6TPE100MI	6.3	100	25
Sanyo	POSCAP	2R5TPE220M7	2.5	220	7
Kemet	T530	T530D227M006ATE006	6.3	220	6
Kemet	T530	T530D337M006ATE010	6.3	330	10
Sanyo	POSCAP	2TPF330M6	2.0	330	6
Sanyo	POSCAP	6TPE330MFL	6.3	330	15

(1) Capacitor Supplier Verification

Please verify availability of capacitors identified in this table.

RoHS, Lead-free and Material Details

Please consult capacitor suppliers regarding material composition, RoHS status, lead-free status, and manufacturing process requirements.

(2) Maximum ESR @ 100kHz, 25°C.

9.3 Transient Response

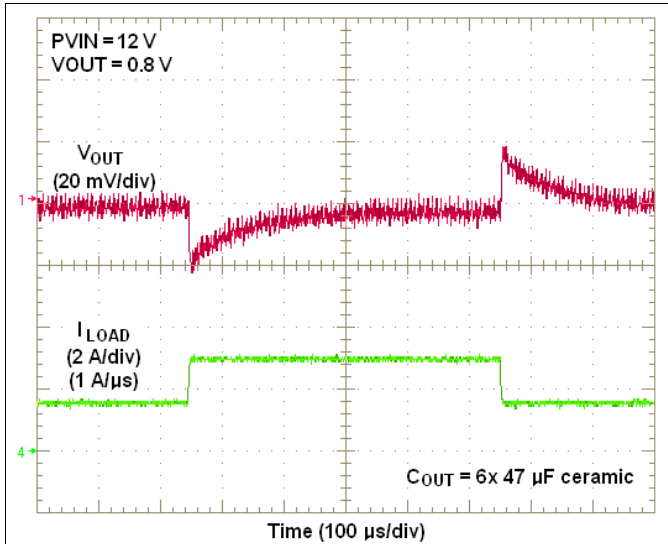

Figure 16. PVIN = 12V, VOUT = 0.8V, 1.5A Load Step

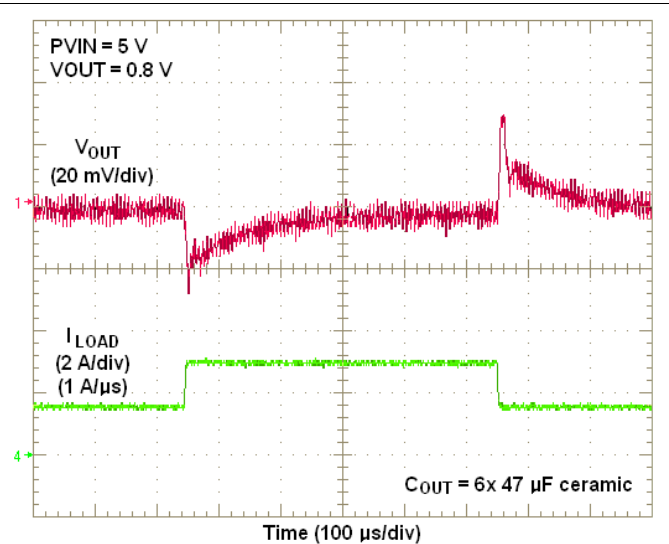

Figure 17. PVIN = 5V, VOUT = 0.8V, 1.5A Load Step

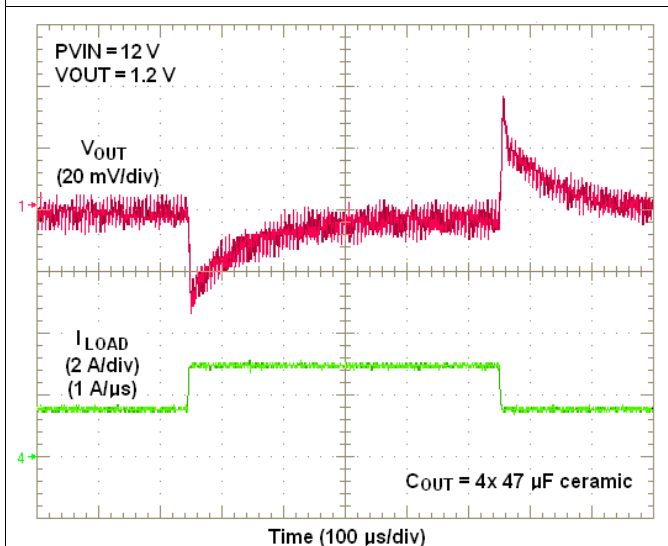

Figure 18. PVIN = 12V, VOUT = 1.2V, 1.5A Load Step

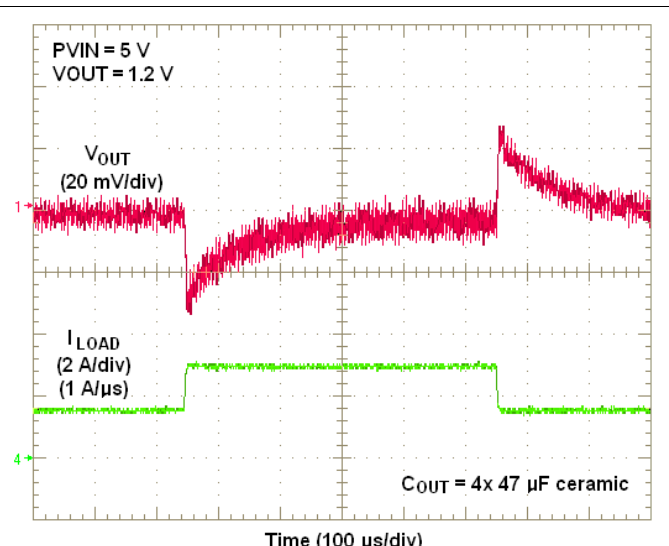
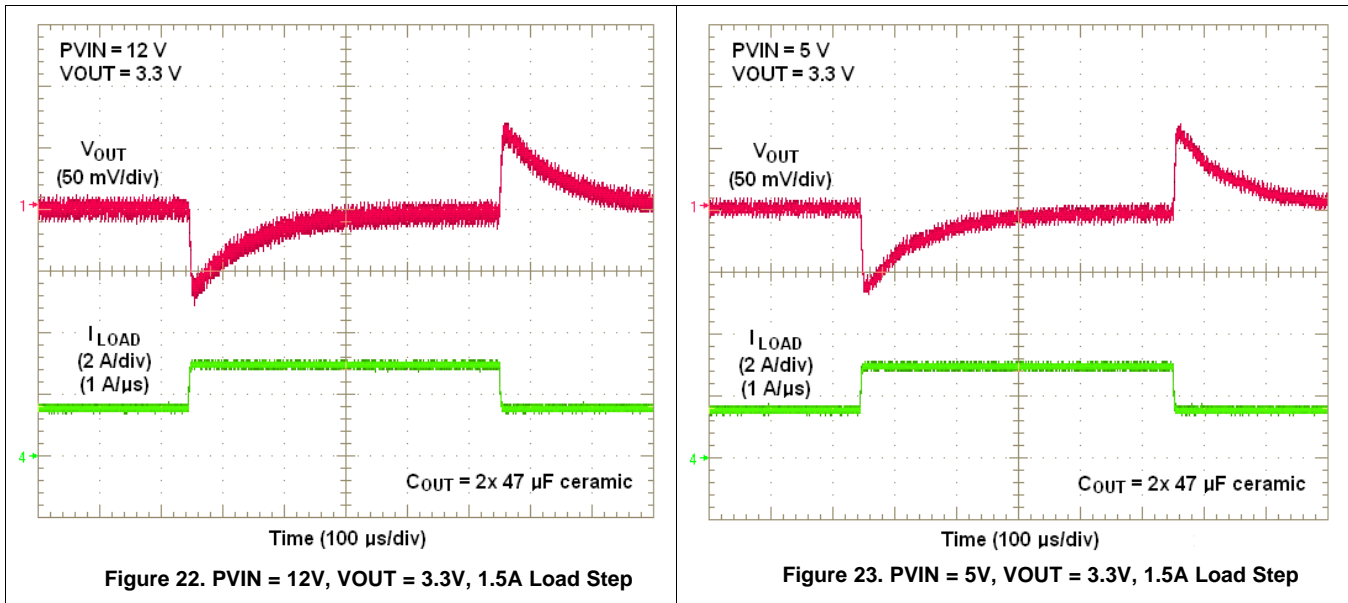
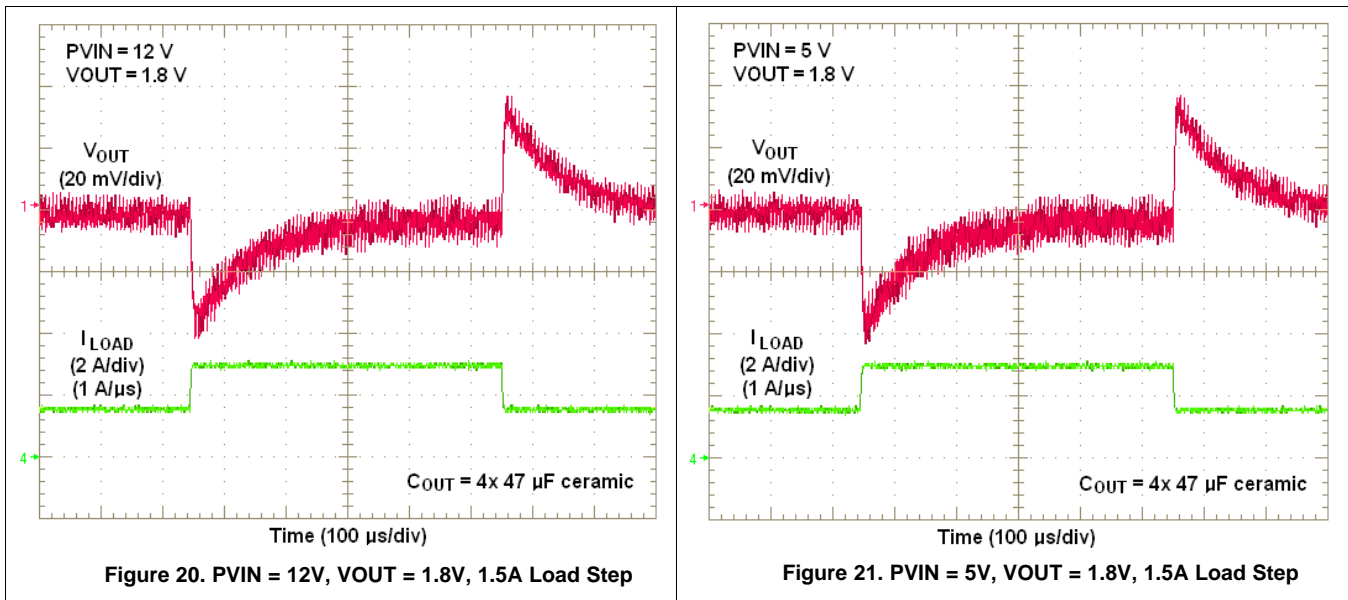

Figure 19. PVIN = 5V, VOUT = 1.2V, 1.5A Load Step

Transient Response (continued)



9.4 Application Schematics

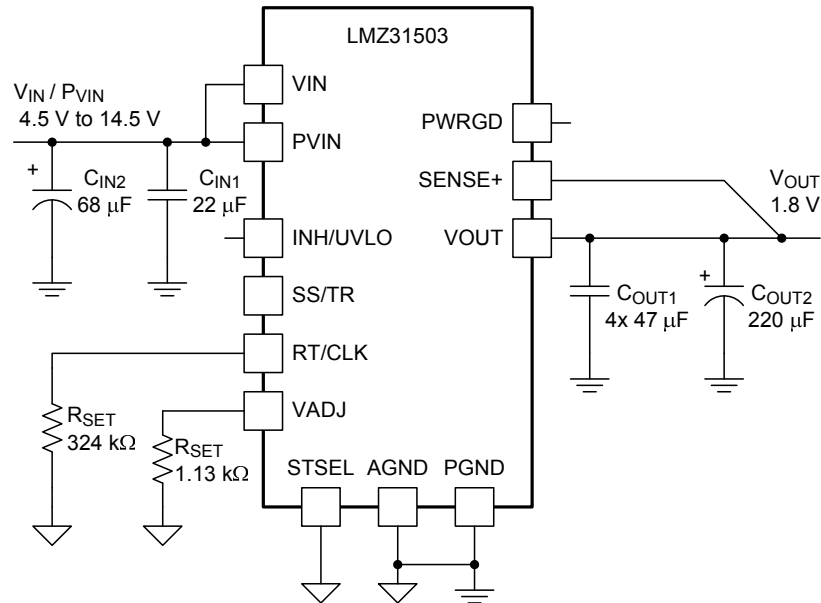

Figure 24. Typical Schematic
PVIN = VIN = 4.5 V to 14.5 V, VOUT = 1.8 V

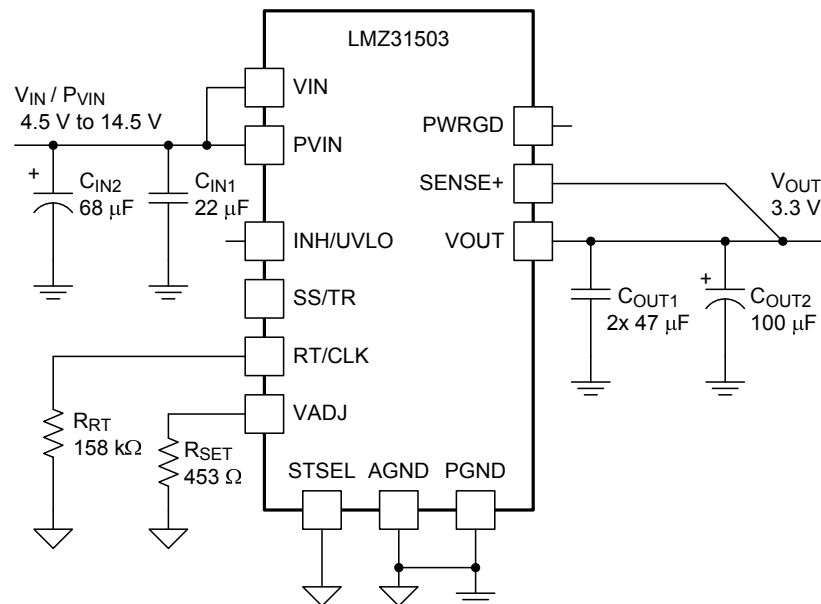

Figure 25. Typical Schematic
PVIN = VIN = 4.5 V to 14.5 V, VOUT = 3.3 V

Application Schematics (continued)

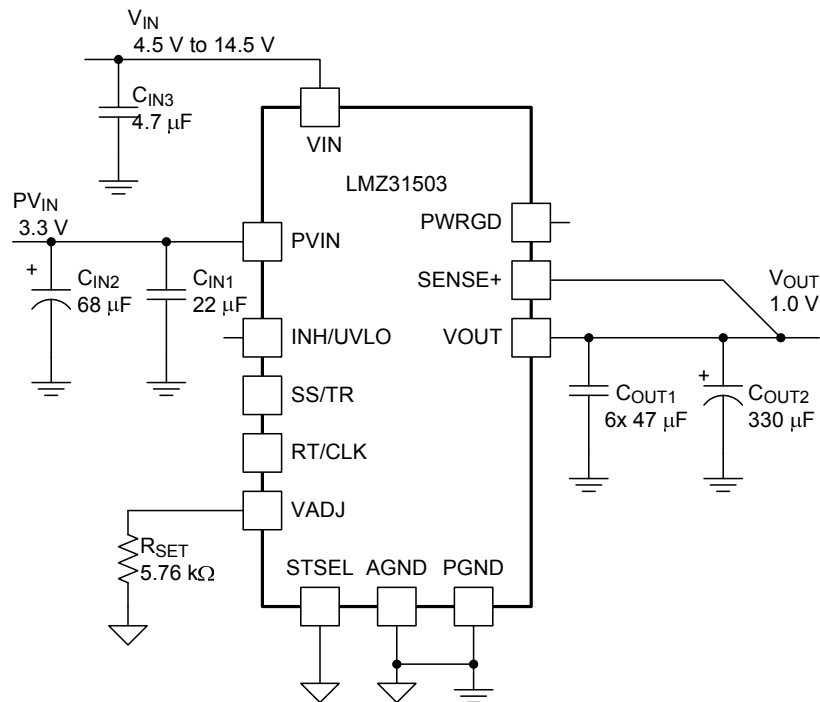

Figure 26. Typical Schematic
PVIN = 3.3 V, VIN = 4.5 V to 14.5 V, VOUT = 1.0 V

9.5 Custom Design With WEBENCH® Tools

[Click here](#) to create a custom design using the LMZ31503 device with the WEBENCH® Power Designer.

1. Start by entering the input voltage (V_{IN}), output voltage (V_{OUT}), and output current (I_{OUT}) requirements.
2. Optimize the design for key parameters such as efficiency, footprint, and cost using the optimizer dial.
3. Compare the generated design with other possible solutions from Texas Instruments.

The WEBENCH Power Designer provides a customized schematic along with a list of materials with real-time pricing and component availability.

In most cases, these actions are available:

- Run electrical simulations to see important waveforms and circuit performance
- Run thermal simulations to understand board thermal performance
- Export customized schematic and layout into popular CAD formats
- Print PDF reports for the design, and share the design with colleagues

Get more information about WEBENCH tools at www.ti.com/WEBENCH.

9.6 VIN and PVIN Input Voltage

The LMZ31503 allows for a variety of applications by using the VIN and PVIN pins together or separately. The VIN voltage supplies the internal control circuits of the device. The PVIN voltage provides the input voltage to the power converter system.

If tied together, the input voltage for the VIN pin and the PVIN pin can range from 4.5 V to 14.5 V. If using the VIN pin separately from the PVIN pin, the VIN pin must be between 4.5 V and 14.5 V, and the PVIN pin can range from as low as 1.6 V to 14.5 V. A voltage divider connected to the INH/UVLO pin can adjust the either input voltage UVLO appropriately. See the [Programmable Undervoltage Lockout \(UVLO\)](#) section of this datasheet for more information.

9.7 Power Good (PWRGD)

The PWRGD pin is an open drain output. Once the voltage on the SENSE+ pin is between 94% and 106% of the set voltage, the PWRGD pin pull-down is released and the pin floats. The recommended pull-up resistor value is between 10 k Ω and 100 k Ω to a voltage source that is 5.5 V or less. The PWRGD pin is in a defined state once VIN is greater than 1.0 V, but with reduced current sinking capability. The PWRGD pin achieves full current sinking capability once the VIN pin is above 4.5V. The PWRGD pin is pulled low when the voltage on SENSE+ is lower than 91% or greater than 109% of the nominal set voltage. Also, the PWRGD pin is pulled low if the input UVLO or thermal shutdown is asserted, the INH pin is pulled low, or the SS/TR pin is below 1.4 V.

9.8 Power-Up Characteristics

When configured as shown in the front page schematic, the LMZ31503 produces a regulated output voltage following the application of a valid input voltage. During the power-up, internal soft-start circuitry slows the rate that the output voltage rises, thereby limiting the amount of in-rush current that can be drawn from the input source. The soft-start circuitry introduces a short time delay from the point that a valid input voltage is recognized. [Figure 27](#) shows the start-up waveforms for a LMZ31503, operating from a 5-V input ($P_{VIN}=V_{IN}$) and with the output voltage adjusted to 1.8 V. [Figure 28](#) shows the start-up waveforms for a LMZ31503 starting up into a pre-biased output voltage. The waveforms were measured with a 2-A constant current load.

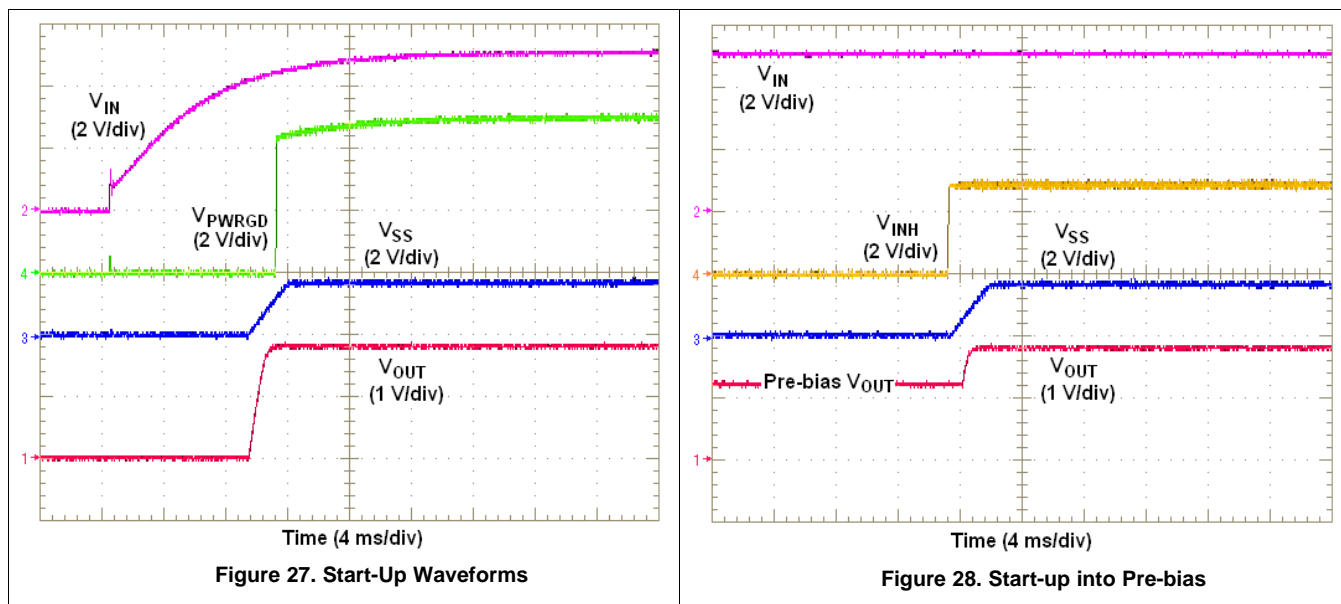

9.9 Pre-Biased Start-Up

The LMZ31503 has been designed to prevent discharging a pre-biased output. During monotonic pre-biased startup, the LMZ31503 does not allow current to sink until the SS/TR pin voltage is higher than 1.4 V.

9.10 Remote Sense

The SENSE+ pin must be connected to V_{OUT} at the load, or at the device pins.

Connecting the SENSE+ pin to V_{OUT} at the load improves the load regulation performance of the device by allowing it to compensate for any I-R voltage drop between its output pins and the load. An I-R drop is caused by the high output current flowing through the small amount of pin and trace resistance. This should be limited to a maximum of 300 mV.

NOTE

The remote sense feature is not designed to compensate for the forward drop of nonlinear or frequency dependent components that may be placed in series with the converter output. Examples include OR-ing diodes, filter inductors, ferrite beads, and fuses. When these components are enclosed by the SENSE+ connection, they are effectively placed inside the regulation control loop, which can adversely affect the stability of the regulator.

9.11 Output On/Off Inhibit (INH)

The INH pin provides electrical on/off control of the device. Once the INH pin voltage exceeds the threshold voltage, the device starts operation. If the INH pin voltage is pulled below the threshold voltage, the regulator stops switching and enters low quiescent current state.

The INH pin has an internal pull-up current source, allowing the user to float the INH pin for enabling the device. If an application requires controlling the INH pin, use an open drain/collector device, or a suitable logic gate to interface with the pin.

Figure 29 shows the typical application of the inhibit function. The Inhibit control has its own internal pull-up to VIN potential. An open-collector or open-drain device is recommended to control this input.

Turning Q1 on applies a low voltage to the inhibit control (INH) pin and disables the output of the supply, shown in Figure 30. If Q1 is turned off, the supply executes a soft-start power-up sequence, as shown in Figure 31. A regulated output voltage is produced within 10 ms. The waveforms were measured with a 2-A constant resistance load.

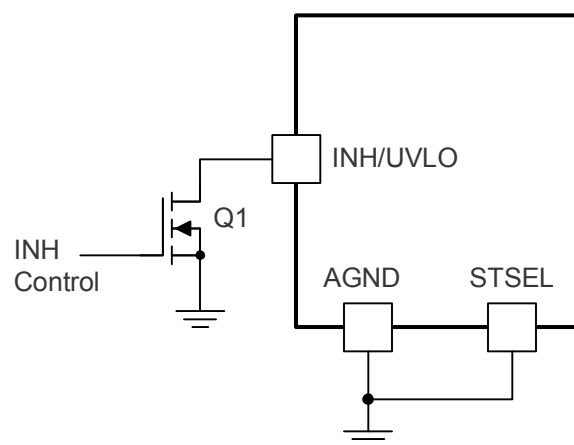

Figure 29. Typical Inhibit Control

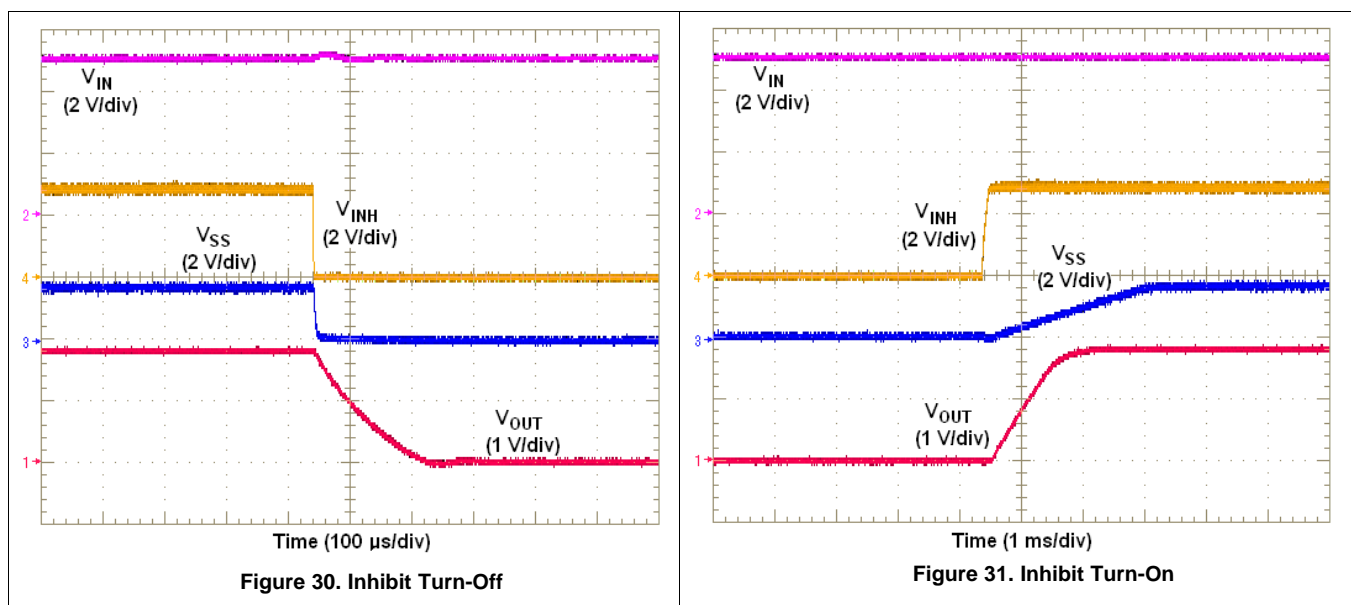

Figure 30. Inhibit Turn-Off

Figure 31. Inhibit Turn-On

9.12 Slow Start (SS/TR)

Connecting the STSEL pin to AGND and leaving SS/TR pin open enables the internal SS capacitor with a slow start interval of approximately 1.1 ms. Adding additional capacitance between the SS pin and AGND increases the slow start time. Table 6 shows an additional SS capacitor connected to the SS/TR pin and the STSEL pin connected to AGND. See Table 6 below for SS capacitor values and timing interval.

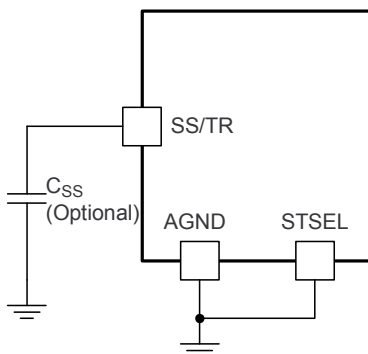

Figure 32. Slow-Start Capacitor (C_{SS}) and STSEL Connection

Table 6. Slow-Start Capacitor Values and Slow-Start Time

C_{SS} (pF)	open	2200	4700	10000	15000	22000	25000
SS Time (msec)	1.1	1.9	2.8	4.6	6.4	8.8	9.8

9.13 Overcurrent Protection

For protection against load faults, the LMZ31503 incorporates output overcurrent protection. Applying a load that exceeds the regulator's overcurrent threshold causes the regulated output to shut down. Following shutdown, the output voltage periodically attempts to recover by initiating a soft-start power-up. This is described as a *hiccup* mode of operation, whereby the module continues in a cycle of successive shutdown and power up until the load fault is removed, as shown in Figure 33. During this period, the average current flowing into the fault is significantly reduced. Once the fault is removed, the module automatically recovers and returns to normal operation, as shown in Figure 34.

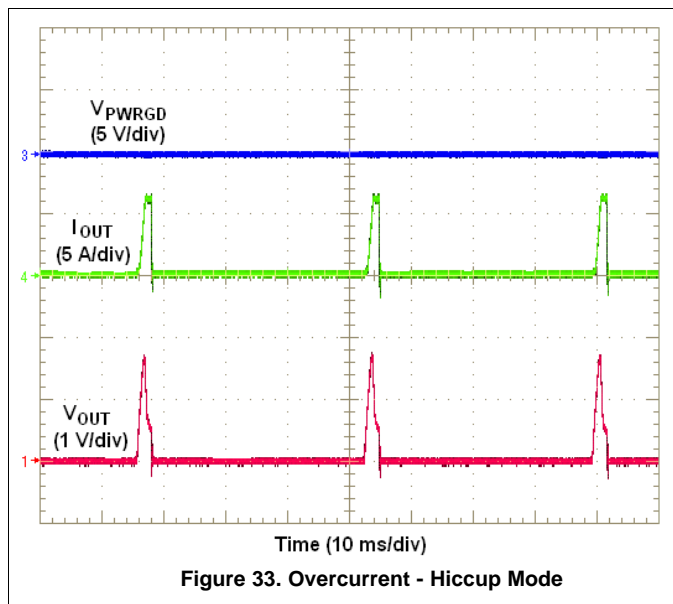

Figure 33. Overcurrent - Hiccup Mode

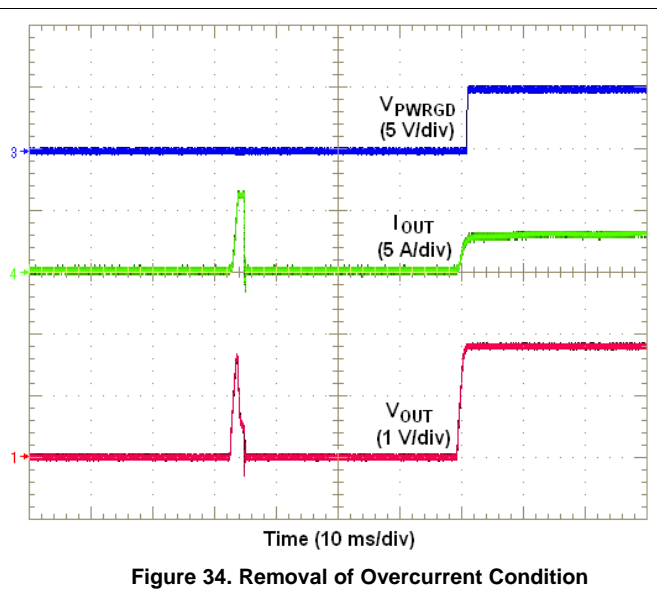

Figure 34. Removal of Overcurrent Condition

9.14 Synchronization (CLK)

An internal phase locked loop (PLL) has been implemented to allow synchronization between 330 kHz and 780 kHz, and to easily switch from RT mode to CLK mode. To implement the synchronization feature, connect a square wave clock signal to the RT/CLK pin with a duty cycle between 20% to 80%. The clock signal amplitude must transition lower than 0.8 V and higher than 2.0 V. The start of the switching cycle is synchronized to the falling edge of RT/CLK pin. In applications where both RT mode and CLK mode are needed, the device can be configured as shown in .

Before the external clock is present, the device works in RT mode and the switching frequency is set by RT resistor (R_{RT}). When the external clock is present, the CLK mode overrides the RT mode. The first time the CLK pin is pulled above the RT/CLK high threshold (2.0 V), the device switches from RT mode to th CLK mode and the RT/CLK pin becomes high impedance as the PLL starts to lock onto the frequency of the external clock. It is not recommended to switch from CLK mode back to RT mode because the internal switching frequency drops to 100 kHz and may shut-down due to internal protection circuits before returning to the switching frequency set by the RT resistor.

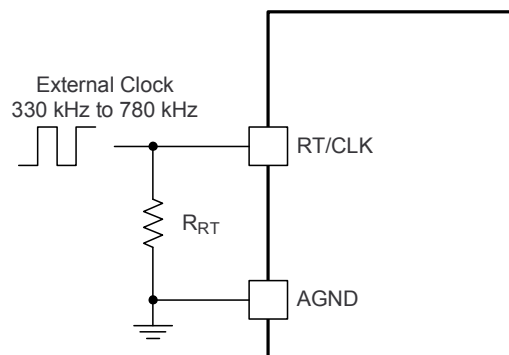

Figure 35. CLK/RT Configuration

The synchronization frequency must be selected based on the output voltages of the devices being synchronized. Table 7 shows the allowable frequencies for a given range of output voltages. For the most efficient solution, always synchronize to the lowest allowable frequency. For example, an application requires synchronizing three LMZ31503 devices with output voltages of 1.2 V, 1.8 V and 2.5 V, all powered from $P_{VIN} = 12$ V. Table 7 shows that all three output voltages can be synchronized to frquencies between 480 kHz to 630 kHz. For best efficiency, choose 480 kHz as the sychronization frequency.

Table 7. Synchronization Frequency vs Output Voltage

SYNCHRONIZATION FREQUENCY (kHz)	R_{RT} (k Ω)	$P_{VIN} = 12$ V		$P_{VIN} = 5$ V	
		V_{OUT} RANGE (V)		V_{OUT} RANGE (V)	
		MIN	MAX	MIN	MAX
330	OPEN	0.8	1.5	0.8	4.3
380	1000	0.8	1.7		
430	499	0.8	2.1		
480	324	0.9	2.5		
530	237	1.0	2.9		
580	191	1.1	3.2		
630	158	1.2	3.7		
680	137	1.3	4.1		
730	118	1.4	4.7		
780	105	1.5	5.5		

9.15 Sequencing (SS/TR)

Many of the common power supply sequencing methods can be implemented using the SS/TR, INH and PWRGD pins. The sequential method is illustrated in Figure 36 using two LMZ31503 devices. The PWRGD pin of the first device is coupled to the INH pin of the second device which enables the second power supply once the primary supply reaches regulation. Figure 37 shows sequential turn-on waveforms of two LMZ31503 devices.

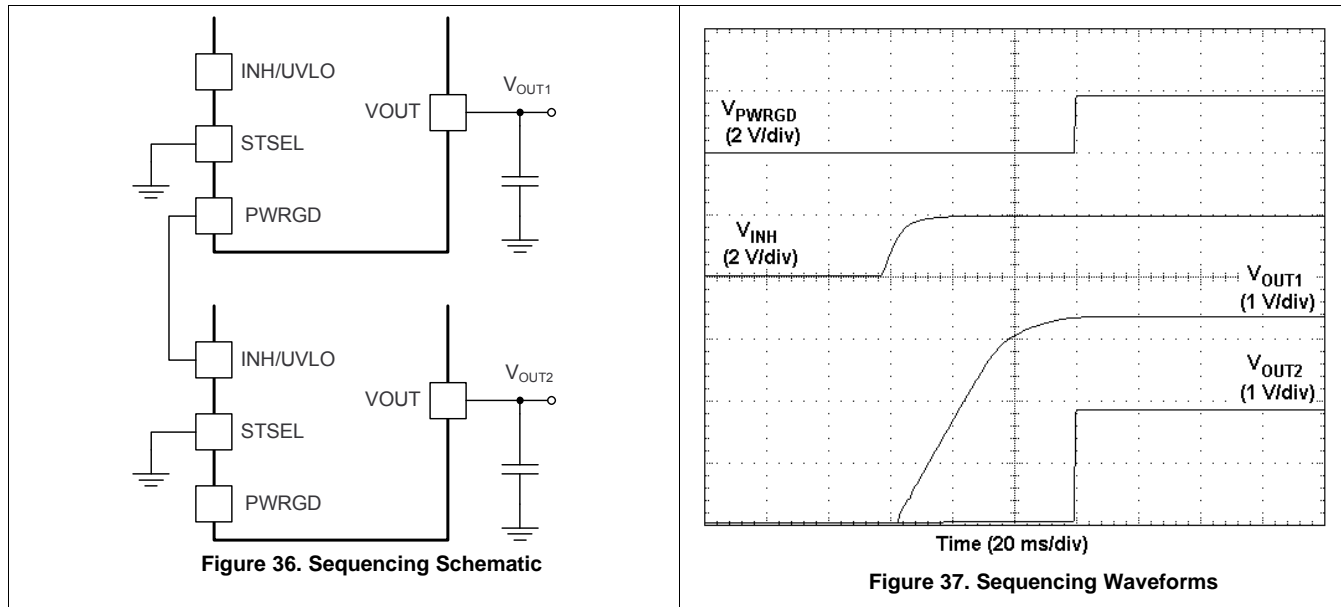

Simultaneous power supply sequencing can be implemented by connecting the resistor network of R1 and R2 shown in Figure 38 to the output of the power supply that needs to be tracked or to another voltage reference source. Figure 39 shows simultaneous turn-on waveforms of two LMZ31503 devices. Use Equation 2 and Equation 3 to calculate the values of R1 and R2.

$$R1 = \frac{(V_{OUT2} \times 12.6)}{0.8} \text{ (k}\Omega\text{)} \quad (2)$$

$$R2 = \frac{0.8 \times R1}{(V_{OUT2} - 0.8)} \text{ (k}\Omega\text{)} \quad (3)$$

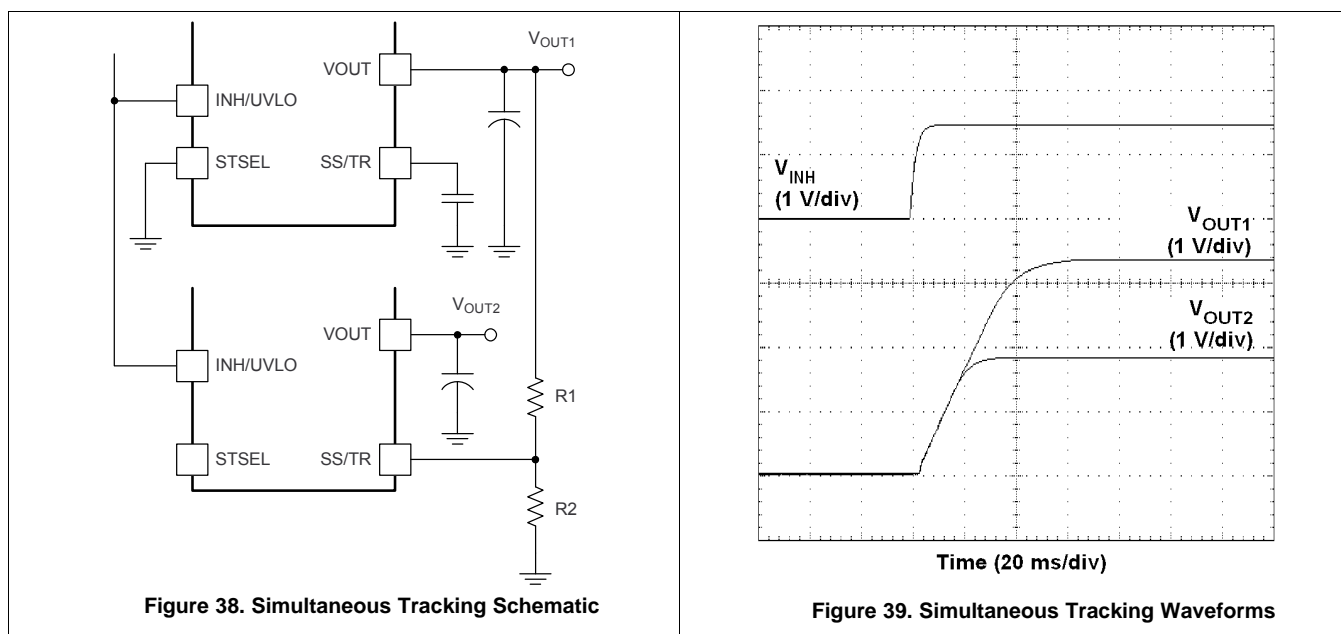

9.16 Programmable Undervoltage Lockout (UVLO)

The LMZ31503 implements internal UVLO circuitry on the VIN pin. The device is disabled when the VIN pin voltage falls below the internal VIN UVLO threshold. The internal VIN UVLO rising threshold is 4.5 V(max) with a typical hysteresis of 150 mV.

If an application requires either a higher UVLO threshold on the VIN pin or a higher UVLO threshold for a combined VIN and PVIN, then the UVLO pin can be configured as shown in [Figure 40](#) or [Figure 41](#). [Table 8](#) lists standard values for R_{UVLO1} and R_{UVLO2} to adjust the VIN UVLO voltage up.

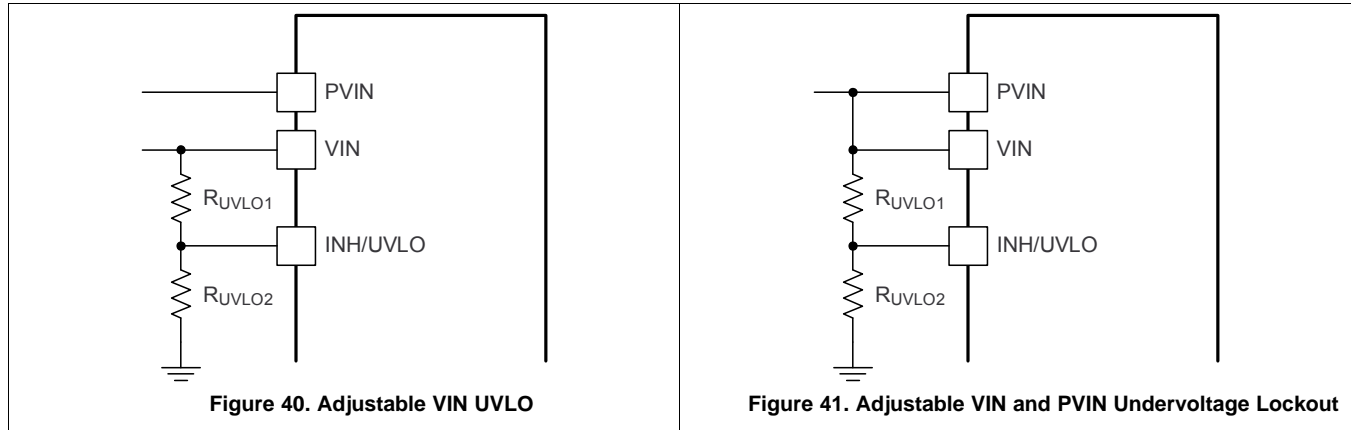

Table 8. Standard Resistor values for Adjusting VIN UVLO

VIN UVLO (V)	5.0	5.5	6.0	6.5	7.0	7.5	8.0	8.5	9.0	9.5	10.0
R_{UVLO1} (k Ω)	68.1	68.1	68.1	68.1	68.1	68.1	68.1	68.1	68.1	68.1	68.1
R_{UVLO2} (k Ω)	21.5	18.7	16.9	15.4	14.0	13.0	12.1	11.3	10.5	9.76	9.31
Hysteresis (mV)	400	415	430	450	465	480	500	515	530	550	565

For a split rail application, if a secondary UVLO on PVIN is required, VIN must be ≥ 4.5 V. [Figure 42](#) shows the PVIN UVLO configuration. Use [Table 9](#) to select R_{UVLO1} and R_{UVLO2} for PVIN. If PVIN UVLO is set for less than 3.0 V, a 5.1-V zener diode should be added to clamp the voltage on the UVLO pin below 6 V.

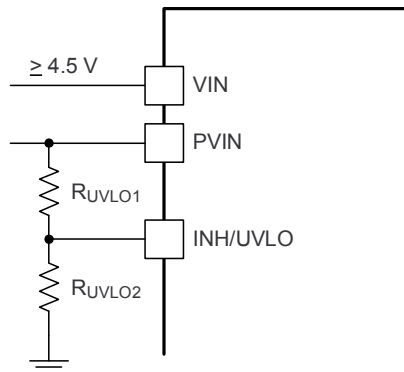

Figure 42. Adjustable PVIN Undervoltage Lockout, (VIN ≥ 4.5 V)

Table 9. Standard Resistor Values for Adjusting PVIN UVLO, (VIN ≥ 4.5 V)

PVIN UVLO (V)	2.0	2.5	3.0	3.5	4.0	4.5	
R_{UVLO1} (k Ω)	68.1	68.1	68.1	68.1	68.1	68.1	For higher PVIN UVLO voltages see Table UV for resistor values
R_{UVLO2} (k Ω)	95.3	60.4	44.2	34.8	28.7	24.3	
Hysteresis (mV)	300	315	335	350	365	385	

9.17 Thermal Shutdown

The internal thermal shutdown circuitry forces the device to stop switching if the junction temperature exceeds 175°C typically. The device reinitiates the power up sequence when the junction temperature drops below 165°C typically.

9.18 Layout Considerations

To achieve optimal electrical and thermal performance, an optimized PCB layout is required. Figure 43 and Figure 44 show two layers of a typical PCB layout. Some considerations for an optimized layout are:

- Use large copper areas for power planes (VIN, VOUT, and PGND) to minimize conduction loss and thermal stress.
- Place ceramic input and output capacitors close to the module pins to minimize high frequency noise.
- Locate additional output capacitors between the ceramic capacitor and the load.
- Place a dedicated AGND copper area beneath the LMZ31503.
- Isolate the PH copper area from the VOUT copper area using the AGND copper area.
- Connect the AGND and PGND copper area at one point; near the output capacitors.
- Place R_{SET} , R_{RT} , and C_{SS} as close as possible to their respective pins.
- Use multiple vias to connect the power planes to internal layers.

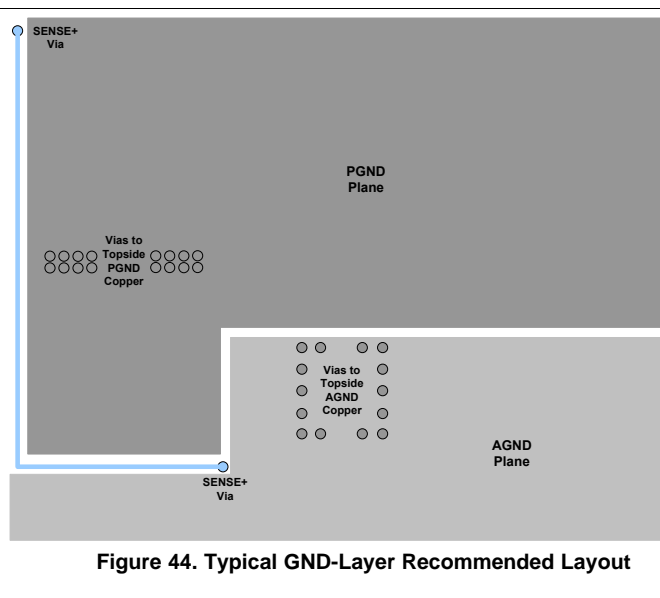
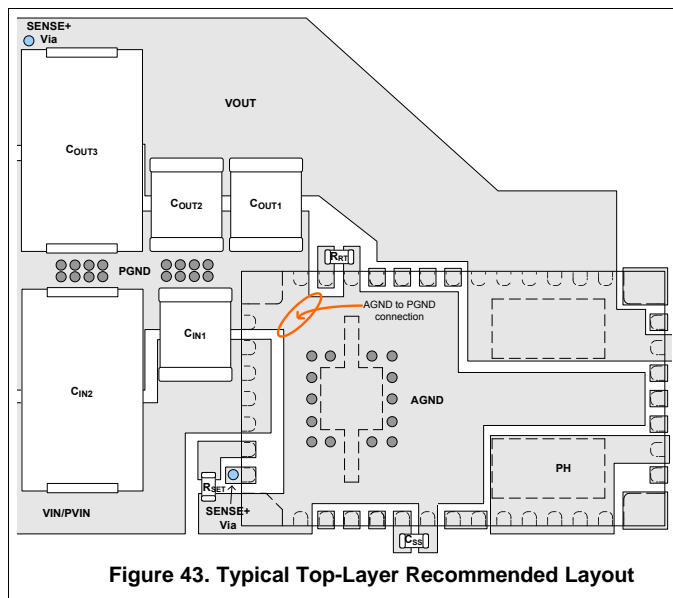

9.19 EMI

The LMZ31503 is compliant with EN55022 Class B radiated emissions. [Figure 45](#) and [Figure 46](#) show typical examples of radiated emissions plots for the LMZ31503 operating from 5V and 12V respectively. Both graphs include the plots of the antenna in the horizontal and vertical positions.

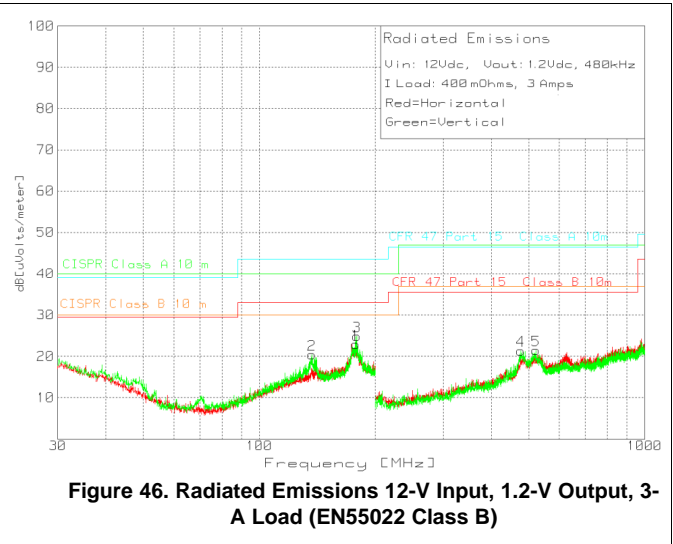
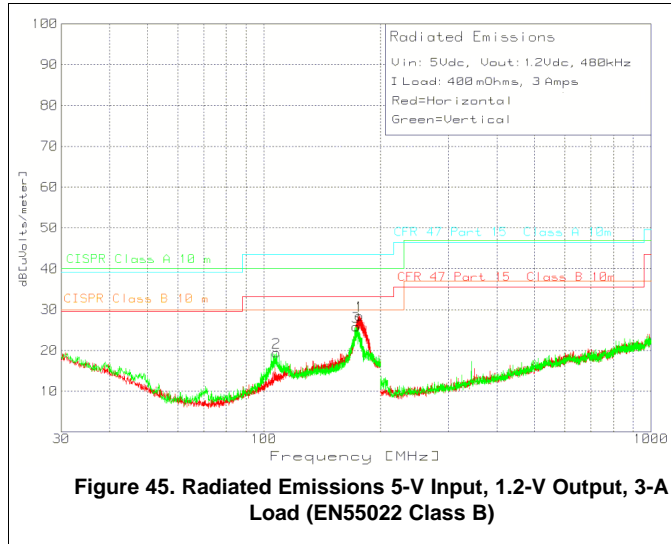

10 Revision History

NOTE: Page numbers for previous revisions may differ from page numbers in the current version.

Changes from Revision A (June 2017) to Revision B	Page
• Added WEBENCH® design links for the LMZ31503.....	1
• Increased the peak reflow temperature and maximum number of reflows to JEDEC specifications for improved manufacturability.....	2
• Added <i>Device Support</i> section	28
• Added <i>Mechanical, Packaging, and Orderable Information</i> section	29

Changes from Original (July 2013) to Revision A	Page
• Added peak reflow and maximum number of reflows information	2

11 Device and Documentation Support

11.1 Device Support

11.1.1 Development Support

11.1.1.1 Custom Design With WEBENCH® Tools

Click [here](#) to create a custom design using the LMZ31503 device with the WEBENCH® Power Designer.

1. Start by entering the input voltage (V_{IN}), output voltage (V_{OUT}), and output current (I_{OUT}) requirements.
2. Optimize the design for key parameters such as efficiency, footprint, and cost using the optimizer dial.
3. Compare the generated design with other possible solutions from Texas Instruments.

The WEBENCH Power Designer provides a customized schematic along with a list of materials with real-time pricing and component availability.

In most cases, these actions are available:

- Run electrical simulations to see important waveforms and circuit performance
- Run thermal simulations to understand board thermal performance
- Export customized schematic and layout into popular CAD formats
- Print PDF reports for the design, and share the design with colleagues

Get more information about WEBENCH tools at www.ti.com/WEBENCH.

11.2 Documentation Support

11.2.1 Related Documentation

For related documentation see the following:

[Soldering Requirements for BQFN Packages](#)

11.3 Receiving Notification of Documentation Updates

To receive notification of documentation updates, navigate to the device product folder on ti.com. In the upper right corner, click on *Alert me* to register and receive a weekly digest of any product information that has changed. For change details, review the revision history included in any revised document.

11.4 Community Resources

The following links connect to TI community resources. Linked contents are provided "AS IS" by the respective contributors. They do not constitute TI specifications and do not necessarily reflect TI's views; see TI's [Terms of Use](#).

TI E2E™ Online Community *TI's Engineer-to-Engineer (E2E) Community*. Created to foster collaboration among engineers. At e2e.ti.com, you can ask questions, share knowledge, explore ideas and help solve problems with fellow engineers.

Design Support *TI's Design Support* Quickly find helpful E2E forums along with design support tools and contact information for technical support.

11.5 Trademarks

E2E is a trademark of Texas Instruments.

WEBENCH is a registered trademark of Texas Instruments.

All other trademarks are the property of their respective owners.

11.6 Electrostatic Discharge Caution



This integrated circuit can be damaged by ESD. Texas Instruments recommends that all integrated circuits be handled with appropriate precautions. Failure to observe proper handling and installation procedures can cause damage.

ESD damage can range from subtle performance degradation to complete device failure. Precision integrated circuits may be more susceptible to damage because very small parametric changes could cause the device not to meet its published specifications.

11.7 Glossary

[SLYZ022](#) — TI Glossary.

This glossary lists and explains terms, acronyms, and definitions.

12 Mechanical, Packaging, and Orderable Information

The following pages include mechanical, packaging, and orderable information. This information is the most current data available for the designated devices. This data is subject to change without notice and revision of this document. For browser-based versions of this data sheet, refer to the left-hand navigation.

12.1 Tape and Reel Information

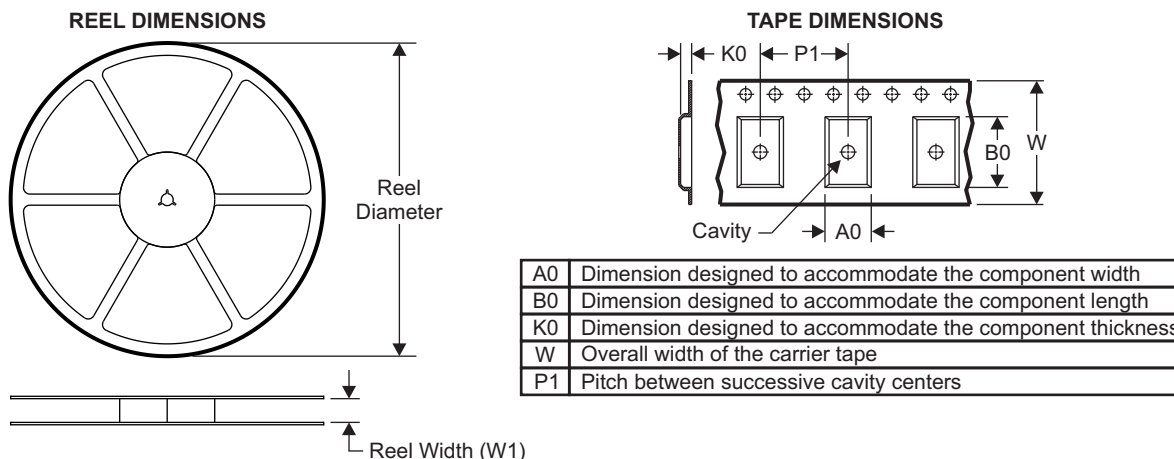

QUADRANT ASSIGNMENTS FOR PIN 1 ORIENTATION IN TAPE

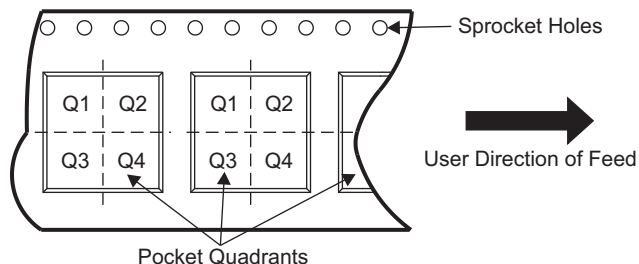

Device	Package Type	Package Drawing	Pins	SPQ	Reel Diameter (mm)	Reel Width W1 (mm)	A0 (mm)	B0 (mm)	K0 (mm)	P1 (mm)	W (mm)	Pin1 Quadrant
LMZ31503RUQR	B1QFN	RUQ	47	500	330.0	24.4	9.35	15.35	3.1	16.0	24.0	Q1
LMZ31503RUQT	B1QFN	RUQ	47	250	330.0	24.4	9.35	15.35	3.1	16.0	24.0	Q1

LMZ31503

SNVS992B –JULY 2013–REVISED APRIL 2018

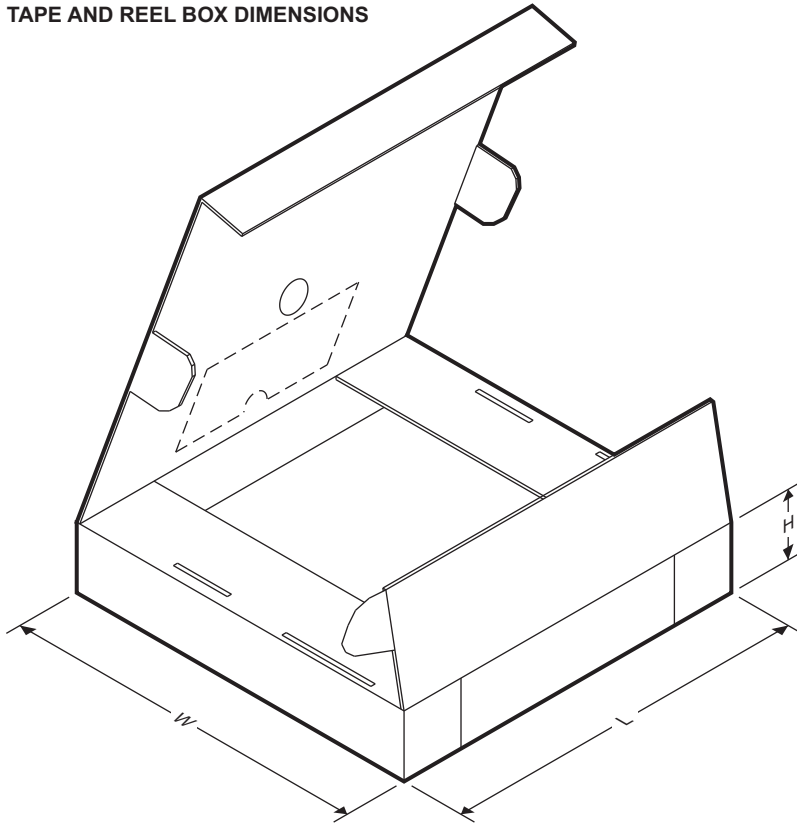
www.ti.com
TAPE AND REEL BOX DIMENSIONS

Device	Package Type	Package Drawing	Pins	SPQ	Length (mm)	Width (mm)	Height (mm)
LMZ31503RUQR	B1QFN	RUQ	47	500	383.0	353.0	58.0
LMZ31503RUQT	B1QFN	RUQ	47	250	383.0	353.0	58.0

PACKAGING INFORMATION

Orderable Device	Status (1)	Package Type	Package Drawing	Pins	Package Qty	Eco Plan (2)	Lead/Ball Finish (6)	MSL Peak Temp (3)	Op Temp (°C)	Device Marking (4/5)	Samples
LMZ31503RUQR	ACTIVE	B1QFN	RUQ	47	500	RoHS (In Work) & Green (In Work)	CU NIPDAU	Level-3-245C-168 HR	-40 to 85	(54320, LMZ31503)	Samples
LMZ31503RUQT	ACTIVE	B1QFN	RUQ	47	250	RoHS (In Work) & Green (In Work)	CU NIPDAU	Level-3-245C-168 HR	-40 to 85	(54320, LMZ31503)	Samples

(1) The marketing status values are defined as follows:

ACTIVE: Product device recommended for new designs.

LIFEBUY: TI has announced that the device will be discontinued, and a lifetime-buy period is in effect.

NRND: Not recommended for new designs. Device is in production to support existing customers, but TI does not recommend using this part in a new design.

PREVIEW: Device has been announced but is not in production. Samples may or may not be available.

OBSOLETE: TI has discontinued the production of the device.

(2) **RoHS:** TI defines "RoHS" to mean semiconductor products that are compliant with the current EU RoHS requirements for all 10 RoHS substances, including the requirement that RoHS substance do not exceed 0.1% by weight in homogeneous materials. Where designed to be soldered at high temperatures, "RoHS" products are suitable for use in specified lead-free processes. TI may reference these types of products as "Pb-Free".

RoHS Exempt: TI defines "RoHS Exempt" to mean products that contain lead but are compliant with EU RoHS pursuant to a specific EU RoHS exemption.

Green: TI defines "Green" to mean the content of Chlorine (Cl) and Bromine (Br) based flame retardants meet JS709B low halogen requirements of <=1000ppm threshold. Antimony trioxide based flame retardants must also meet the <=1000ppm threshold requirement.

(3) MSL, Peak Temp. - The Moisture Sensitivity Level rating according to the JEDEC industry standard classifications, and peak solder temperature.

(4) There may be additional marking, which relates to the logo, the lot trace code information, or the environmental category on the device.

(5) Multiple Device Markings will be inside parentheses. Only one Device Marking contained in parentheses and separated by a "~" will appear on a device. If a line is indented then it is a continuation of the previous line and the two combined represent the entire Device Marking for that device.

(6) Lead/Ball Finish - Orderable Devices may have multiple material finish options. Finish options are separated by a vertical ruled line. Lead/Ball Finish values may wrap to two lines if the finish value exceeds the maximum column width.

Important Information and Disclaimer: The information provided on this page represents TI's knowledge and belief as of the date that it is provided. TI bases its knowledge and belief on information provided by third parties, and makes no representation or warranty as to the accuracy of such information. Efforts are underway to better integrate information from third parties. TI has taken and continues to take reasonable steps to provide representative and accurate information but may not have conducted destructive testing or chemical analysis on incoming materials and chemicals. TI and TI suppliers consider certain information to be proprietary, and thus CAS numbers and other limited information may not be available for release.

In no event shall TI's liability arising out of such information exceed the total purchase price of the TI part(s) at issue in this document sold by TI to Customer on an annual basis.

TAPE AND REEL INFORMATION

QUADRANT ASSIGNMENTS FOR PIN 1 ORIENTATION IN TAPE

*All dimensions are nominal

Device	Package Type	Package Drawing	Pins	SPQ	Reel Diameter (mm)	Reel Width W1 (mm)	A0 (mm)	B0 (mm)	K0 (mm)	P1 (mm)	W (mm)	Pin1 Quadrant
LMZ31503RUQR	B1QFN	RUQ	47	500	330.0	12.4	3.75	3.75	1.15	8.0	12.0	Q1
LMZ31503RUQT	B1QFN	RUQ	47	250	180.0	12.4	3.75	3.75	1.15	8.0	12.0	Q1

TAPE AND REEL BOX DIMENSIONS

*All dimensions are nominal

Device	Package Type	Package Drawing	Pins	SPQ	Length (mm)	Width (mm)	Height (mm)
LMZ31503RUQR	B1QFN	RUQ	47	500	367.0	367.0	35.0
LMZ31503RUQT	B1QFN	RUQ	47	250	210.0	185.0	35.0

THERMAL PAD MECHANICAL DATA

RUQ (R-PB1QFN-N47)

PLASTIC QUAD FLATPACK NO-LEAD

THERMAL INFORMATION

This package incorporates an exposed thermal pad that is designed to be attached directly to an external heatsink. The thermal pad must be soldered directly to the printed circuit board (PCB). After soldering, the PCB can be used as a heatsink. In addition, through the use of thermal vias, the thermal pad can be attached directly to the appropriate copper plane shown in the electrical schematic for the device, or alternatively, can be attached to a special heatsink structure designed into the PCB. This design optimizes the heat transfer from the integrated circuit (IC).

For information on the Quad Flatpack No-Lead (QFN) package and its advantages, refer to Application Report, QFN/SON PCB Attachment, Texas Instruments Literature No. SLUA271. This document is available at www.ti.com.

The exposed thermal pad dimensions for this package are shown in the following illustration.

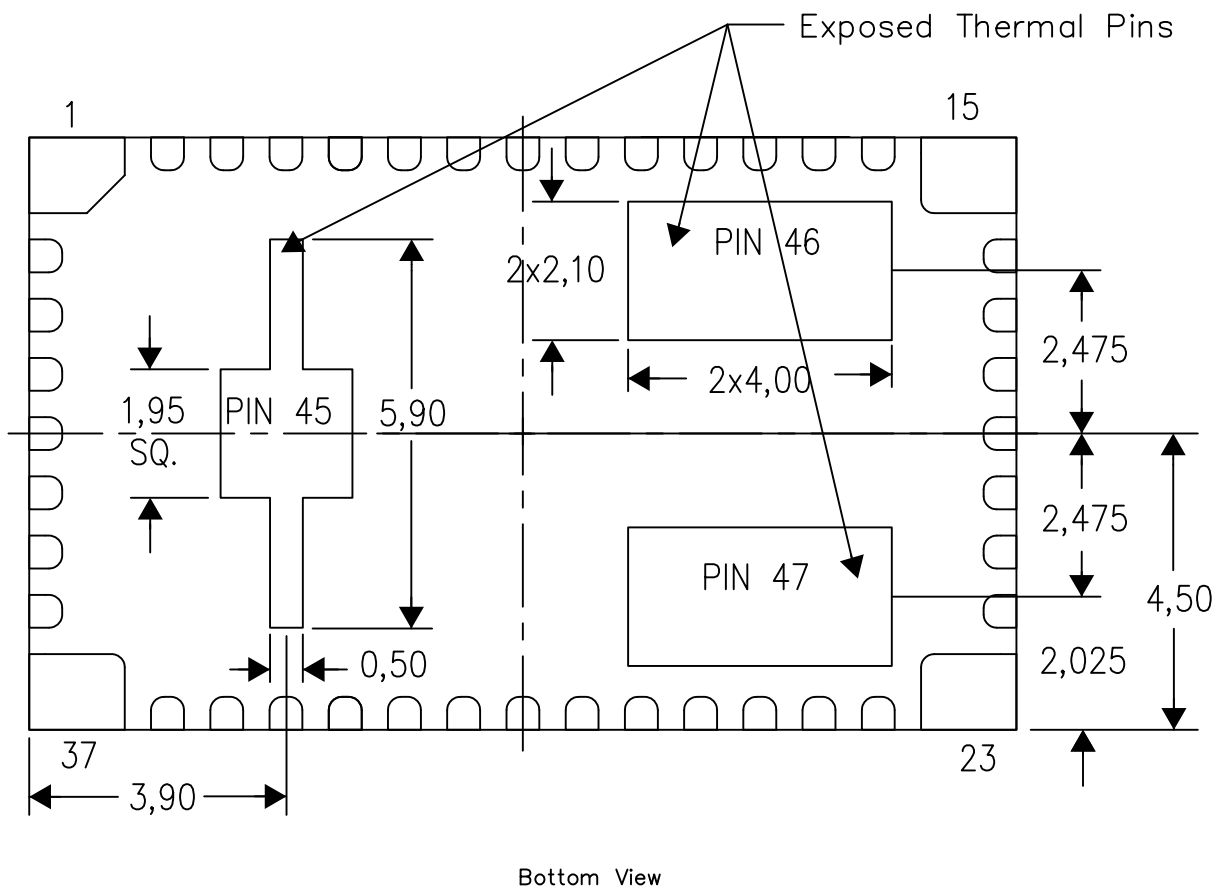

Exposed Thermal Pad Dimensions

4210496/D 07/14

NOTE: A. All linear dimensions are in millimeters

RUQ (R-PB1QFN-N47)

PLASTIC QUAD FLATPACK NO-LEAD

Example Stencil Design (Note E)
Stencil Thickness = 0,125mm

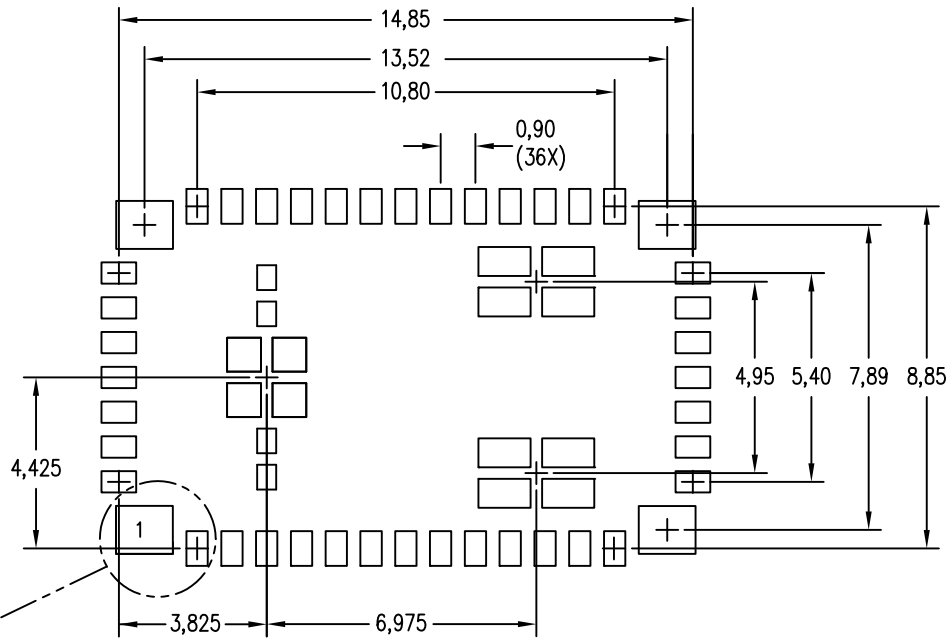

60% solder coverage on center pads

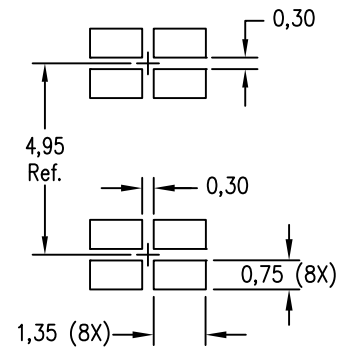
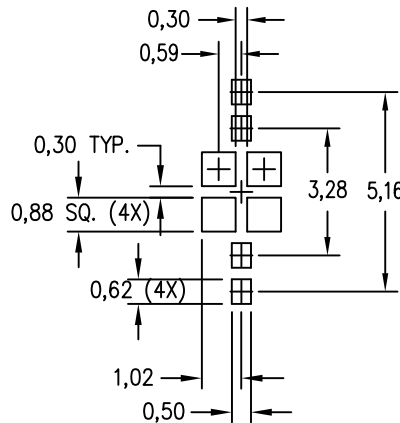
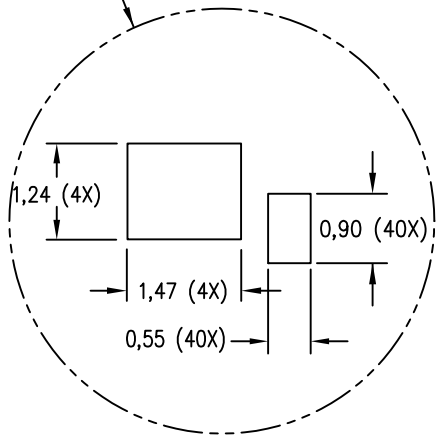

4210717-3/1 10/14

NOTES:

- E. Laser cutting apertures with trapezoidal walls and also rounding corners will offer better paste release. Customers should contact their board assembly site for stencil design recommendations. Refer to IPC 7525 for stencil design considerations.

IMPORTANT NOTICE AND DISCLAIMER

TI PROVIDES TECHNICAL AND RELIABILITY DATA (INCLUDING DATASHEETS), DESIGN RESOURCES (INCLUDING REFERENCE DESIGNS), APPLICATION OR OTHER DESIGN ADVICE, WEB TOOLS, SAFETY INFORMATION, AND OTHER RESOURCES "AS IS" AND WITH ALL FAULTS, AND DISCLAIMS ALL WARRANTIES, EXPRESS AND IMPLIED, INCLUDING WITHOUT LIMITATION ANY IMPLIED WARRANTIES OF MERCHANTABILITY, FITNESS FOR A PARTICULAR PURPOSE OR NON-INFRINGEMENT OF THIRD PARTY INTELLECTUAL PROPERTY RIGHTS.

These resources are intended for skilled developers designing with TI products. You are solely responsible for (1) selecting the appropriate TI products for your application, (2) designing, validating and testing your application, and (3) ensuring your application meets applicable standards, and any other safety, security, or other requirements. These resources are subject to change without notice. TI grants you permission to use these resources only for development of an application that uses the TI products described in the resource. Other reproduction and display of these resources is prohibited. No license is granted to any other TI intellectual property right or to any third party intellectual property right. TI disclaims responsibility for, and you will fully indemnify TI and its representatives against, any claims, damages, costs, losses, and liabilities arising out of your use of these resources.

TI's products are provided subject to TI's Terms of Sale (www.ti.com/legal/termsofsale.html) or other applicable terms available either on ti.com or provided in conjunction with such TI products. TI's provision of these resources does not expand or otherwise alter TI's applicable warranties or warranty disclaimers for TI products.

Mailing Address: Texas Instruments, Post Office Box 655303, Dallas, Texas 75265
Copyright © 2019, Texas Instruments Incorporated

Looking for pricing, stock, or lifecycle information?

Click below to explore more details on WIN SOURCE:

 [View LMZ31503RUQR on WIN SOURCE](#)

 [Texas Instruments](#) Information

Optimize Your Supply Chain with WIN SOURCE Solutions

-  Global Sourcing Solution
-  Obsolete Management
-  Cost Control Management
-  Shortage Management
-  Alternative Solution
-  Excess Inventory Management