



**THE DATASHEET OF
MC100EL1648DT**



5 V ECL Voltage Controlled Oscillator Amplifier

MC100EL1648

Description

The MC100EL1648 is a voltage controlled oscillator amplifier that requires an external parallel tank circuit consisting of the inductor (L) and capacitor (C). A varactor diode may be incorporated into the tank circuit to provide a voltage variable input for the oscillator (VCO). This device may also be used in many other applications requiring a fixed frequency clock.

The MC100EL1648 is ideal in applications requiring a local oscillator, systems that include electronic test equipment, and digital high-speed telecommunications.

The MC100EL1648 is based on the VCO circuit topology of the MC1648. The MC100EL1648 uses advanced bipolar process technology which results in a design which can operate at an extended frequency range.

The ECL output circuitry of the MC100EL1648 is not a traditional open emitter output structure and instead has an on-chip termination emitter resistor, R_E , with a nominal value of 510Ω . This facilitates direct ac-coupling of the output signal into a transmission line. Because of this output configuration, an external pull-down resistor is not required to provide the output with a dc current path. This output is intended to drive one ECL load (3.0 pF). If the user needs to fanout the signal, an ECL buffer such as the EL16 (EL11, EL14) type Line Receiver/Driver should be used.

Features

- Typical Operating Frequency Up to 1100 MHz
- Low-Power 19 mA at 5.0 Vdc Power Supply
- PECL Mode Operating Range: $V_{CC} = 4.2 \text{ V}$ to 5.5 V with $V_{EE} = 0 \text{ V}$
- NECL Mode Operating Range: $V_{CC} = 0 \text{ V}$ with $V_{EE} = -4.2 \text{ V}$ to -5.5 V
- Input Capacitance = 6.0 pF (TYP)
- These are Pb-Free Devices

NOTE: The MC100EL1648 is NOT useable as a crystal oscillator.

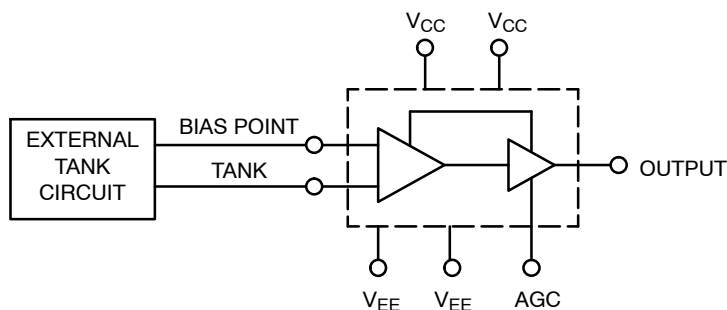

Figure 1. Logic Diagram



ON Semiconductor®

www.onsemi.com



SOIC-8 NB
D SUFFIX
CASE 751-07



TSSOP-8
DT SUFFIX
CASE 948R-02

MARKING DIAGRAMS*

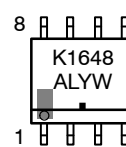

SOIC-8 NB

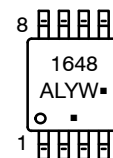

TSSOP-8

- A = Assembly Location
- L = Wafer Lot
- Y = Year
- W = Work Week
- = Pb-Free Package

(Note: Microdot may be in either location)

*For additional marking information, refer to Application Note [AND8002/D](#).

ORDERING INFORMATION

See detailed ordering and shipping information in the package dimensions section on page 11 of this data sheet.

MC100EL1648

Table 1. PIN DESCRIPTION

Pin No.	Symbol	Description
1	TANK	OSC Input Voltage
2, 3	V _{CC}	Positive Supply
4	OUT	ECL Output
5	AGC	Automatic Gain Control Input
6, 7	V _{EE}	Negative Output
8	BIAS	OSC Input Reference Voltage

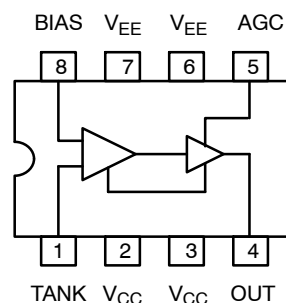

Warning: All V_{CC} and V_{EE} pins must be externally connected to Power Supply to guarantee proper operation.

Figure 2. Pinout Assignments

Table 2. ATTRIBUTES

Characteristic	Value
Internal Input Pulldown Resistor	N/A
Internal Input Pullup Resistor	N/A
ESD Protection Human Body Model Machine Model Charged Device Model	> 1 kV > 100 V > 1 kV
Moisture Sensitivity, Indefinite Time Out of Drypack (Note 1)	Pb-Free Pkg
SOIC-8 TSSOP-8	Level 1 Level 3
Flammability Rating Oxygen Index: 23 to 34	UL 94 V-0 @ 0.125 in
Transistor Count	11
Meets or Exceeds JEDEC Standard EIA/JESD78 IC Latchup Test	

1. For additional Moisture Sensitivity information, refer to Application Note [AND8003/D](#).

Table 3. MAXIMUM RATINGS

Symbol	Parameter	Condition 1	Condition 2	Rating	Unit
V _{CC}	Power Supply PECL Mode	V _{EE} = 0 V		7 to 0	V
V _{EE}	Power Supply NECL Mode	V _{CC} = 0 V		-7 to 0	V
V _I	PECL Mode Input Voltage NECL Mode Input Voltage	V _{EE} = 0 V V _{CC} = 0 V	V _I ≤ V _{CC} V _I ≥ V _{EE}	6 to 0 -6 to 0	V V
I _{out}	Output Current	Continuous Surge		50 100	MA mA
T _A	Operating Temperature Range			-40 to +85	°C
T _{stg}	Storage Temperature Range			-65 to +150	°C
θ _{JA}	Thermal Resistance (Junction-to-Ambient)	0 lfpm 500 lfpm	SOIC-8 SOIC-8	190 130	°C/W °C/W
θ _{JC}	Thermal Resistance (Junction-to-Case)	Standard Board	SOIC-8	41 to 44	°C/W
θ _{JA}	Thermal Resistance (Junction-to-Ambient)	0 lfpm 500 lfpm	TSSOP-8 TSSOP-8	185 140	°C/W °C/W
θ _{JC}	Thermal Resistance (Junction-to-Case)	Standard Board	TSSOP-8	41 to 44	°C/W
T _{sol}	Wave Solder	<2 to 3 sec @ 260°C		265	°C

Stresses exceeding those listed in the Maximum Ratings table may damage the device. If any of these limits are exceeded, device functionality should not be assumed, damage may occur and reliability may be affected.

MC100EL1648

Table 4. PECL DC CHARACTERISTICS $V_{CC} = 5.0\text{ V}$; $V_{EE} = 0.0\text{ V} + 0.8 / -0.5\text{ V}$ (Note 2)

Symbol	Characteristic	-40°C			25°C			85°C			Unit
		Min	Typ	Max	Min	Typ	Max	Min	Typ	Max	
I_{EE}	Power Supply Current	13	19	25	13	19	25	13	19	25	mA
V_{OH}	Output HIGH Voltage (Note 3)	3950	4170	4610	3950	4170	4610	3950	4170	4610	mV
V_{OL}	Output LOW Voltage (Note 3)	3040	3410	3600	3040	3410	3600	3040	3410	3600	mV
AGC	Automatic Gain Control Input	1690		1980	1690		1980	1690		1980	mV
V_{BIAS}	Bias Voltage (Note 4)	1650		1800	1650		1800	1650		1800	mV
V_{IL}		1.5			1.35			1.2			V
V_{IH}				2.0			1.85			1.7	V
I_L	Input Current		-5.0			-5.0			-5.0		mA

NOTE: Device will meet the specifications after thermal equilibrium has been established when mounted in a test socket or printed circuit board with maintained transverse airflow greater than 500 lpm.

2. Output parameters vary 1:1 with V_{CC} .

3. 1.0 M Ω impedance.

4. This measurement guarantees the dc potential at the bias point for purposes of incorporating a varactor tuning diode at this point.

Table 5. NECL DC CHARACTERISTICS $V_{CC} = 0.0\text{ V}$; $V_{EE} = -5.0\text{ V} + 0.8 / -0.5\text{ V}$ (Note 5)

Symbol	Characteristic	-40°C			25°C			85°C			Unit
		Min	Typ	Max	Min	Typ	Max	Min	Typ	Max	
I_{EE}	Power Supply Current	13	19	25	13	19	25	13	19	25	mA
V_{OH}	Output HIGH Voltage (Note 6)	-1050	-830	-399	-1050	-830	-399	-1050	-830	-399	mV
V_{OL}	Output LOW Voltage (Note 6)	-1960	-1590	-1400	-1960	-1590	-1400	-1960	-1590	-1400	mV
AGC	Automatic Gain Control Input	-3310		-3020	-3310		-3020	-3310		-3020	mV
V_{BIAS}	Bias Voltage (Note 7)	-3350		-3200	-3350		-3200	-3350		-3200	mV
V_{IL}		-3.5			-3.65			-3.8			V
V_{IH}				-3.0			-3.15			-3.3	V
I_L	Input Current		-5.0			-5.0			-5.0		mA

NOTE: Device will meet the specifications after thermal equilibrium has been established when mounted in a test socket or printed circuit board with maintained transverse airflow greater than 500 lpm.

5. Output parameters vary 1:1 with V_{CC} .

6. 1.0 M Ω impedance.

7. This measurement guarantees the dc potential at the bias point for purposes of incorporating a varactor tuning diode at this point.

MC100EL1648

GENERIC TEST CIRCUITS: Bypass to Supply Opposite GND

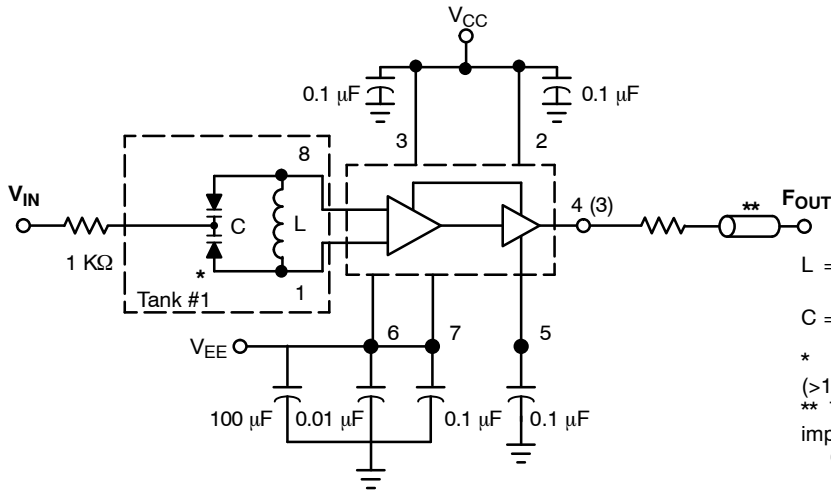

L = Micro Metal torroid #T20-22, 8 turns #30
 Enameled Copper wire (@ 40 nH)
 C = MMBV609

* Use high impedance probe (>1.0 MΩ must be used).
 ** The 1200 Ω resistor and the scope termination impedance constitute a 25:1 attenuator probe. Coax shall be CT-070-50 or equivalent.

Tank Circuit Option #1, Varactor Diode

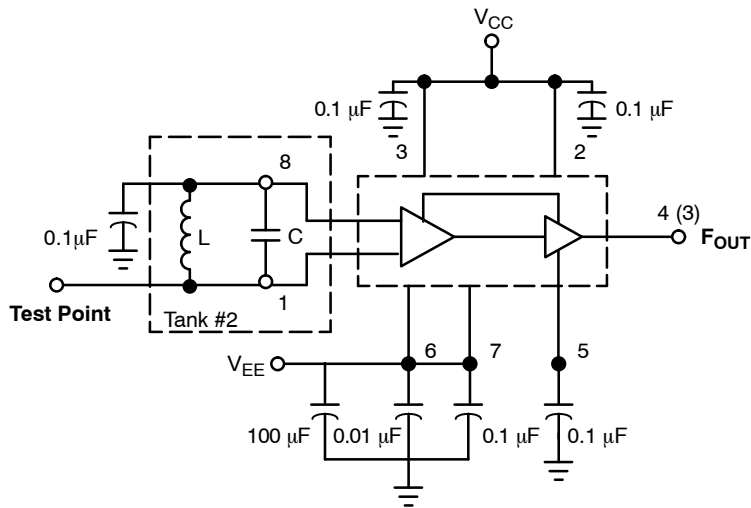

L = Micro Metal torroid #T20-22, 8 turns #30
 Enameled Copper wire (@ 40 nH)
 C = 3.0-35pF Variable Capacitance (@ 10 pF)

Note 1 Capacitor for tank may be variable type. (See Tank Circuit #3.)
 Note 2 Use high impedance probe (> 1 MΩ).

Tank Circuit Option #2, Fixed LC

Figure 3. Typical Test Circuit with Alternate Tank Circuits

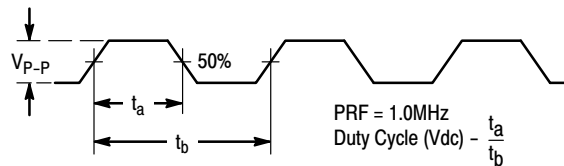

Figure 4. Output Waveform

OPERATION THEORY

Figure 5 illustrates the simplified circuit schematic for the MC100EL1648. The oscillator incorporates positive feedback by coupling the base of transistor Q6 to the collector of Q7. An automatic gain control (AGC) is incorporated to limit the current through the emitter-coupled pair of transistors (Q7 and Q6) and allow optimum frequency response of the oscillator. In order to maintain the high quality factor (Q) on the oscillator, and provide high spectral purity at the output, transistor Q4 is used to translate the oscillator signal to the output differential pair Q2 and Q3. Figure 16 indicates the high spectral purity of the oscillator output (pin 4 on 8-pin SOIC). Transistors

Q2 and Q3, in conjunction with output transistor Q1, provide a highly buffered output that produces a square wave. The typical output waveform can be seen in Figure 4. The bias drive for the oscillator and output buffer is provided by Q9 and Q11 transistors. In order to minimize current, the output circuit is realized as an emitter-follower buffer with an on chip pull-down resistor R_E .

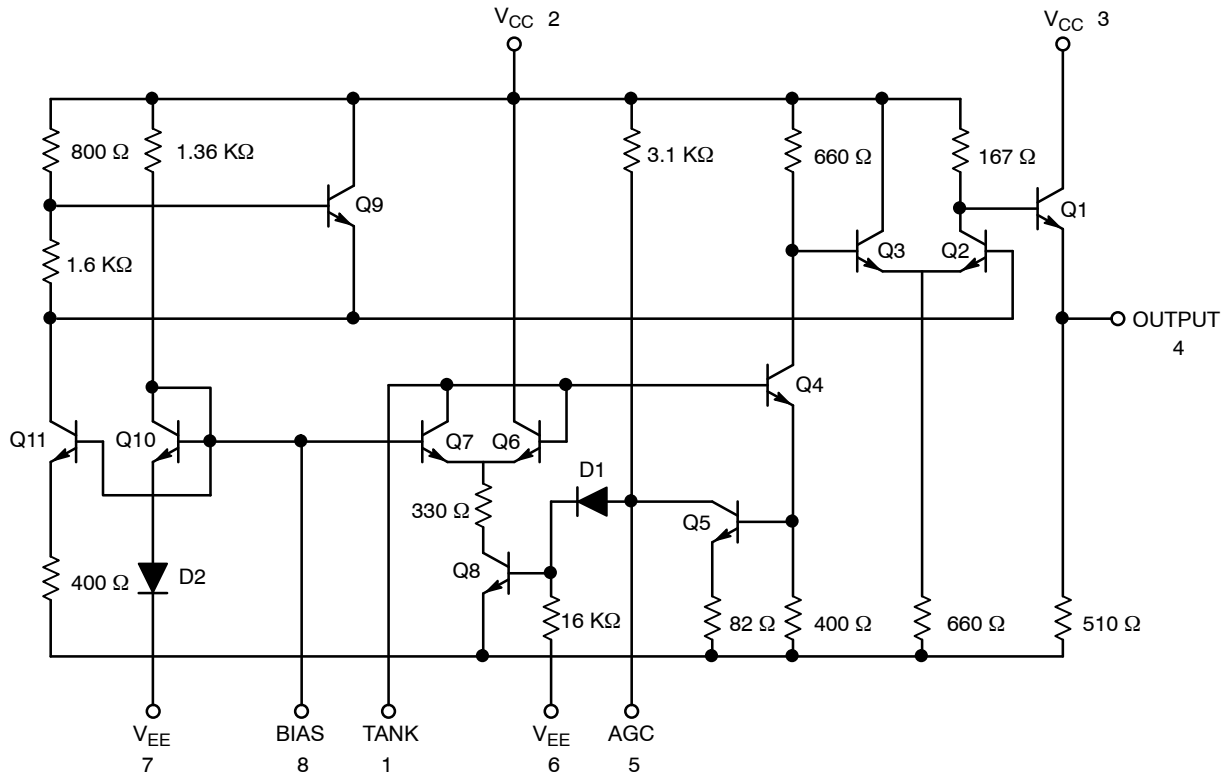
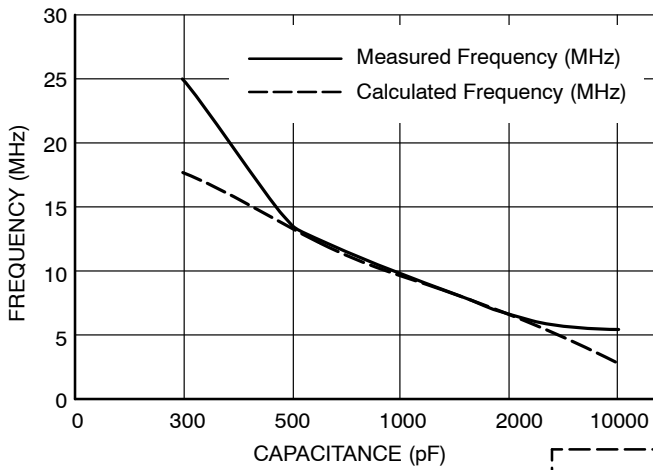

Figure 5. Circuit Schematic

MC100EL1648



L = Micro Metal torroid #T20-22, 8 turns #30
 Enamled Copper wire (@ 40 nH)
 C = 3.0-35 pF Variable Capacitance (@ 10 pF)

* The 1200 Ω resistor and the scope termination impedance constitute a 25:1 attenuator probe.
 Coax shall be CT-070-50 or equivalent.

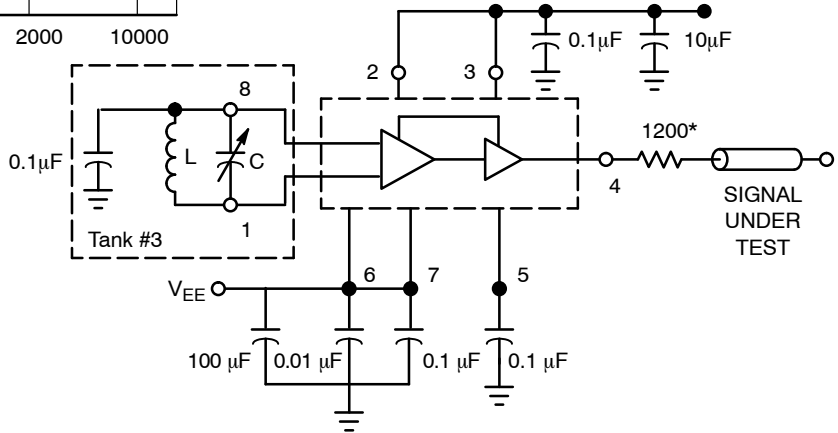
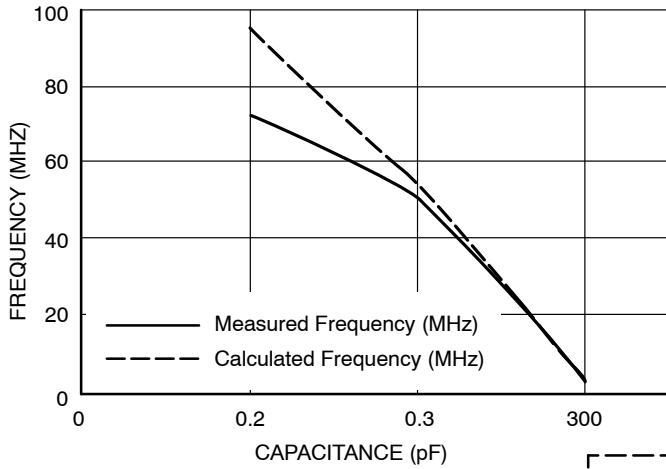

Figure 6. Low Frequency Plot



L = Micro Metal torroid #T20-22, 8 turns #30
 Enamled Copper wire (@ 40 nH)
 C = 3.0-35 pF Variable Capacitance (@ 10 pF)

* The 1200 Ω resistor and the scope termination impedance constitute a 25:1 attenuator probe.
 Coax shall be CT-070-50 or equivalent.

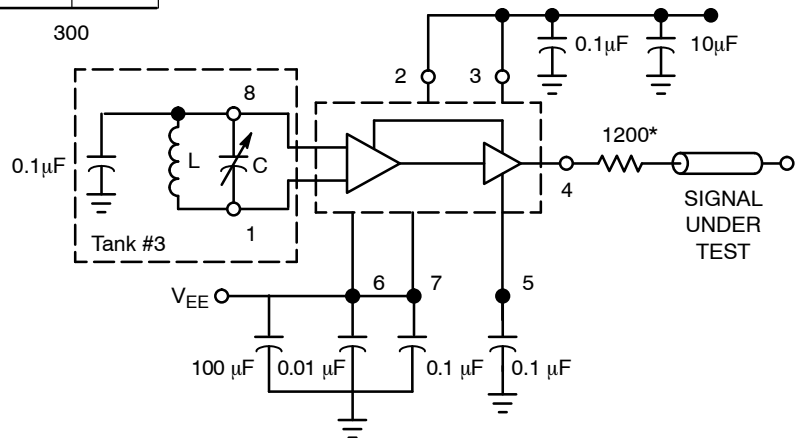
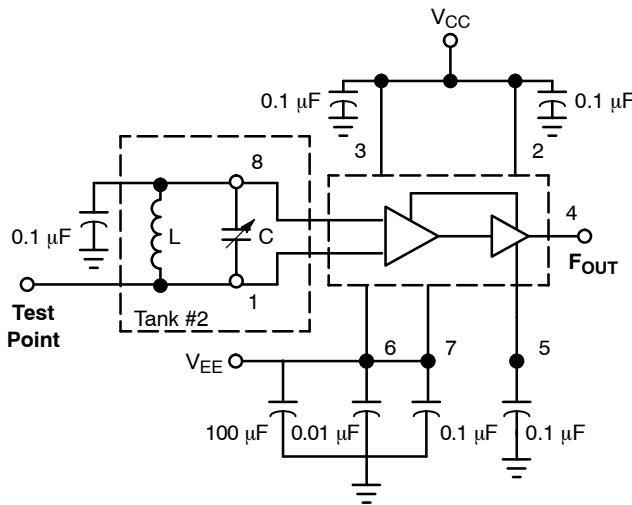
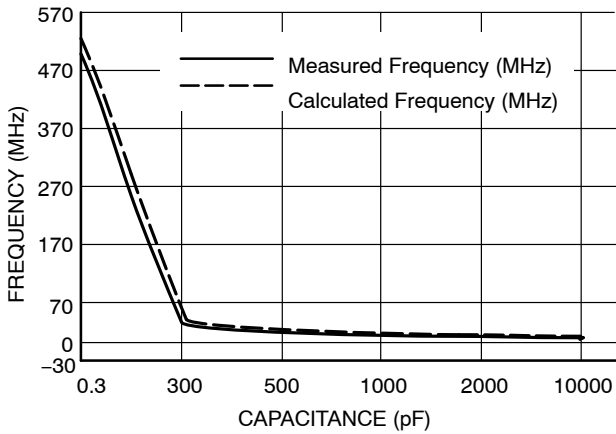

Figure 7. High Frequency Plot

FIXED FREQUENCY MODE

The MC100EL1648 external tank circuit components are used to determine the desired frequency of operation as shown in Figure 8, tank option #2. The tank circuit components have direct impact on the tuning sensitivity, I_{EE}, and phase noise performance. Fixed frequency of the tank circuit is usually realized by an inductor and capacitor (LC network) that contains a high Quality factor (Q). The plotted curve indicates various fixed frequencies obtained with a single inductor and variable capacitor. The Q of the components in the tank circuit has a direct impact on the resulting phase noise of the oscillator. In general, when the Q is high the oscillator will result in lower phase noise.



- L = Micro Metal torroid #T20-22, 8 turns #30 Enameled Copper wire (@ 40 nH)
- C = 3.0-35 pF Variable Capacitance (@ 10 pF)
- Note 1 Capacitor for tank may be variable type. (See Tank Circuit #3.)
- Note 2 Use high impedance probe (> 1 MΩ).
- Q_L ≥ 100

Figure 8. Fixed Frequency LC Tank

Only high quality surface-mount RF chip capacitors should be used in the tank circuit at high frequencies. These

capacitors should have very low dielectric loss (high-Q). At a minimum, the capacitors selected should be operating at 100 MHz below their series resonance point. As the desired frequency of operation increases, the values of the tank capacitor will decrease since the series resonance point is a function of the capacitance value. Typically, the inductor is realized as a surface-mount chip or a wound coil. In addition, the lead inductance and board inductance and capacitance also have an impact on the final operating point. The following equation will help to choose the appropriate values for your tank circuit design.

$$f_0 = \frac{1}{2\pi \sqrt{L_T * C_T}}$$

Where

L_T = Total Inductance

C_T = Total Capacitance

Figure 9 and Figure 10 represent the ideal curve of inductance/capacitance versus frequency with one known tank component. This helps the designer of the tank circuit to choose desired value of inductor/capacitor component for the wanted frequency. The lead inductance and board inductance and capacitance will also have an impact on the tank component values (inductor and capacitor).

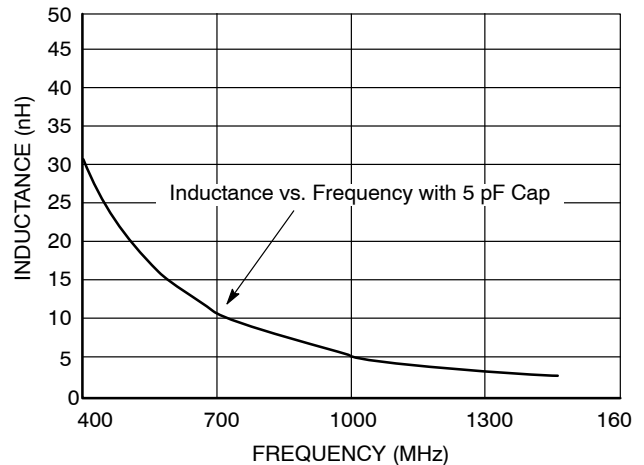

Figure 9. Capacitor Value Known (5 pF)

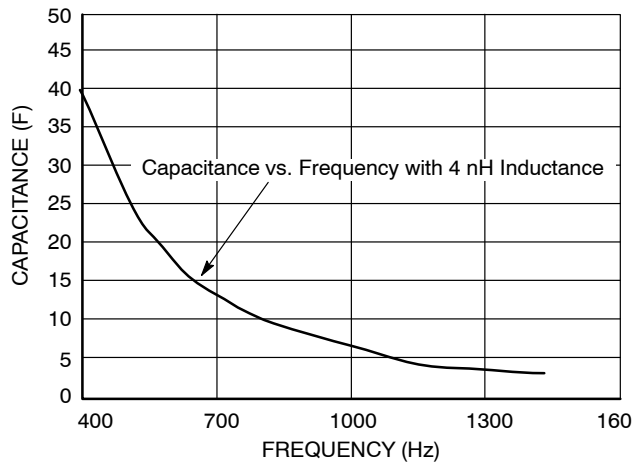

Figure 10. Inductor Value Known (4 nH)

VOLTAGE CONTROLLED MODE

The tank circuit configuration presented in Figure 11, Voltage Controlled Varactor Mode, allows the VCO to be tuned across the full operating voltage of the power supply. Deriving from Figure 6, the tank capacitor, C, is replaced with a varactor diode whose capacitance changes with the voltage applied, thus changing the resonant frequency at which the VCO tank operates as shown in Figure 3, tank option #1. The capacitive component in Equation 1 also needs to include the input capacitance of the device and other circuit and parasitic elements.

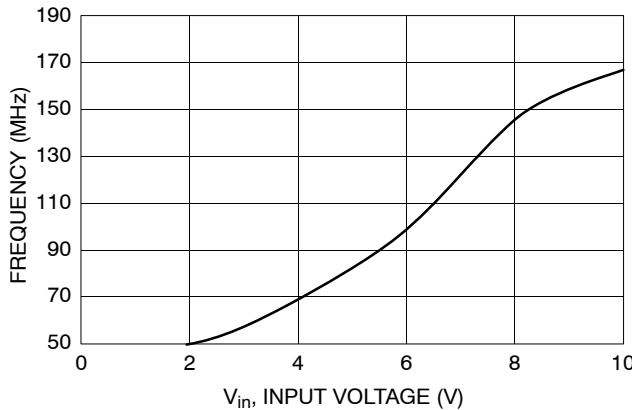
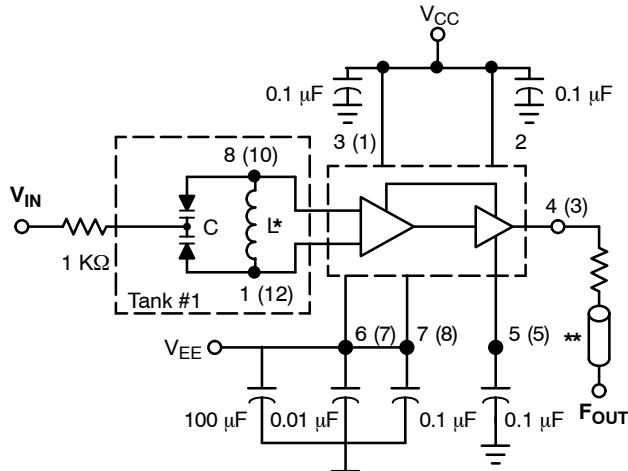

Figure 12. Plot 1. Dual Varactor MMBV609, VIN vs. Frequency



*Use high impedance probe ($\geq 1.0 \text{ Meg}\Omega$ must be used).
 **The 1200 Ω resistor and the scope termination impedance constitute a 25:1 attenuator probe. Coax shall be CT-070-50 or equivalent.

L = Micro Metal toroid #T20-22, 8 turns #30
 Enameled Copper wire (@ 40 nH)
 C = MMBV609

Figure 11. Voltage Controlled Varactor Mode

When operating the oscillator in the voltage controlled mode with Tank Circuit #1 (Figure 3), it should be noted that the cathode of the varactor diode (D), pin 8 (for 8 lead package) or pin 10 (for 14 lead package) should be biased at least 1.4 V above V_{EE}.

Typical transfer characteristics employing the capacitance of the varactor diode (plus the input capacitance of the device, about 6.0 pF typical) in the voltage controlled mode is shown in Plot 1, Dual Varactor MMBV609 V_{in} vs. Frequency. Figure 6, Figure 7, and Figure 8 show the accuracy of the measured frequency with the different variable capacitance values. The 1.0 k Ω resistor in Figure 11 is used to protect the varactor diode during testing. It is not necessary as long as the dc input voltage does not cause the diode to become forward biased. The tuning range of the oscillator in the voltage controlled mode may be calculated as follows:

$$\frac{f_{\max}}{f_{\min}} = \frac{\sqrt{C_D(\max) + C_S}}{\sqrt{C_D(\min) + C_S}}$$

Where

$$f_{\min} = \frac{1}{2\pi\sqrt{L(C_D(\max) + C_S)}}$$

Where

C_S = Shunt Capacitance (input plus external capacitance)

C_D = Varactor Capacitance as a function of bias voltage

Good RF and low-frequency bypassing is necessary on the device power supply pins. Capacitors on the AGC pin and the input varactor trace should be used to bypass the AGC point and the VCO input (varactor diode), guaranteeing only dc levels at these points. For output frequency operation between 1.0 MHz and 50 MHz, a 0.1 μF capacitor is sufficient. At higher frequencies, smaller values of capacitance should be used; at lower frequencies, larger values of capacitance. At high frequencies, the value of bypass capacitors depends directly on the physical layout of the system. All bypassing should be as close to the package pins as possible to minimize unwanted lead inductance. Several different capacitors may be needed to bypass various frequencies.

MC100EL1648

WAVE-FORM CONDITIONING – SINE OR SQUARE WAVE

The peak-to-peak swing of the tank circuit is set internally by the AGC pin. Since the voltage swing of the tank circuit provides the drive for the output buffer, the AGC potential directly affects the output waveform. If it is desired to have a sine wave at the output of the MC100EL1648, a series resistor is tied from the AGC point to the most negative power potential (ground if positive volt supply is used, -5.2 V if a negative supply is used) as shown in

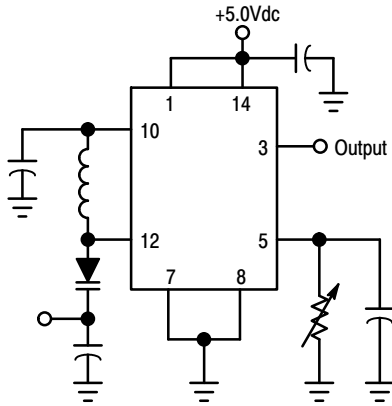

Figure 13. Method of Obtaining a Sine-Wave Output

Figure 13. At frequencies above 100 MHz typical, it may be desirable to increase the tank circuit peak-to-peak voltage in order to shape the signal into a more square waveform at the output of the MC100EL1648. This is accomplished by tying a series resistor (1.0 k Ω minimum) from the AGC to the most positive power potential (+5.0 V if a positive volt supply is used, ground if a -5.2 V supply is used). Figure 14 illustrates this principle.

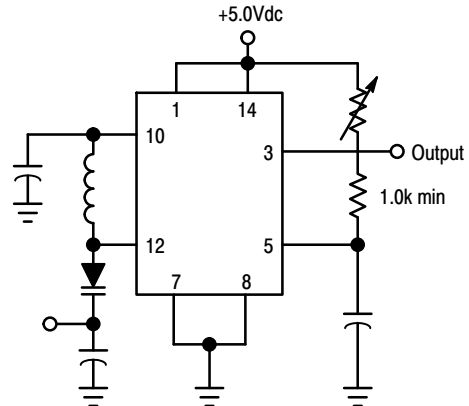
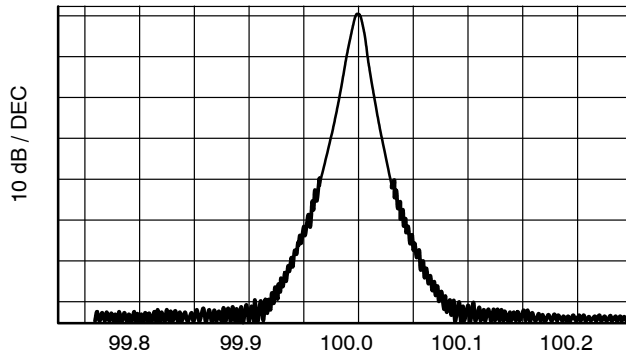

Figure 14. Method of Extending the Useful Range of the MC100EL1648 (Square Wave Output)

MC100EL1648

SPECTRAL PURITY



B.W. = 10 kHz, Center Frequency = 100 MHz
 Scan Width = 50 kHz/div, Vertical Scale = 10 dB/div

Figure 15. Spectral Purity

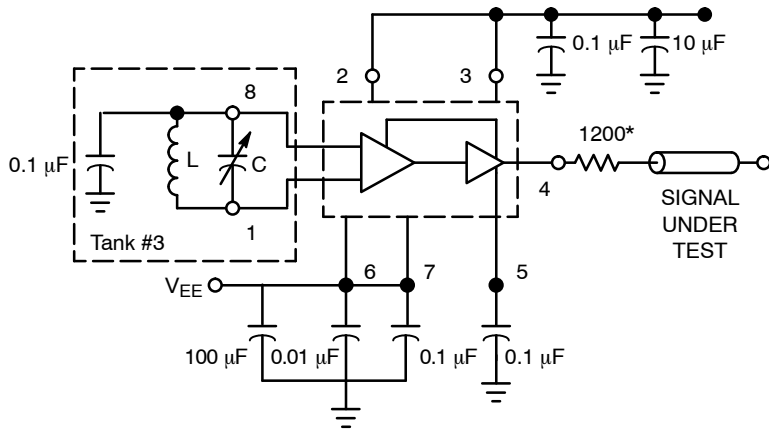

L = Micro Metal torroid #T20-22, 8 turns #30
 Enameled Copper wire (@ 40 nH)
 C = 3.0-35 pF Variable Capacitance (@ 10 pF)

** The 1200 Ω resistor and the scope termination impedance constitute a 25:1 attenuator probe.
 Coax shall be CT-070-50 or equivalent.

Spectral Purity Test Circuit

Figure 16. Spectral Purity of Signal Output for 200 MHz Testing

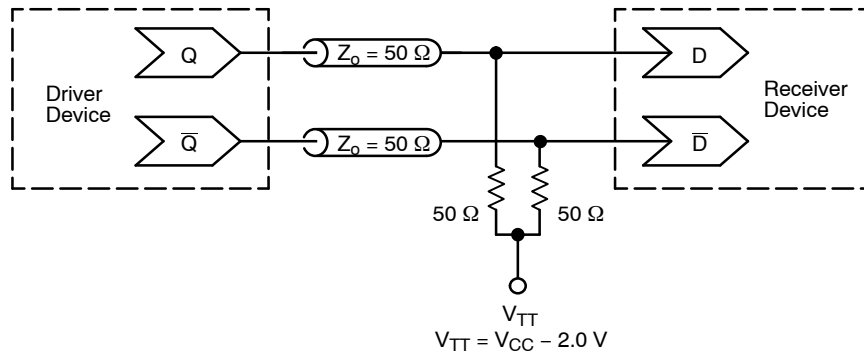

Figure 17. Typical Termination for Output Driver and Device Evaluation
 (See Application Note [AND8020/D](#) - Termination of ECL Logic Devices.)

MC100EL1648

ORDERING INFORMATION

Device	Package	Shipping†
MC100EL1648DG	SOIC-8 NB (Pb-Free)	2500 / Tape & Reel
MC100EL1648DTR2G	TSSOP-8 (Pb-Free)	2500 / Tape & Reel

†For information on tape and reel specifications, including part orientation and tape sizes, please refer to our Tape and Reel Packaging Specifications Brochure, BRD8011/D.

Resource Reference of Application Notes

- AN1405/D** – ECL Clock Distribution Techniques
- AN1406/D** – Designing with PECL (ECL at +5.0 V)
- AN1503/D** – ECLinPS™ I/O SPiCE Modeling Kit
- AN1504/D** – Metastability and the ECLinPS Family
- AN1568/D** – Interfacing Between LVDS and ECL
- AN1672/D** – The ECL Translator Guide
- AND8001/D** – Odd Number Counters Design
- AND8002/D** – Marking and Date Codes
- AND8020/D** – Termination of ECL Logic Devices
- AND8066/D** – Interfacing with ECLinPS
- AND8090/D** – AC Characteristics of ECL Devices

ECLinPS is a trademark of Semiconductor Components Industries, LLC (SCILLC) or its subsidiaries in the United States and/or other countries.

MECHANICAL CASE OUTLINE PACKAGE DIMENSIONS



SCALE 1:1

SOIC-8 NB
CASE 751-07
ISSUE AK

DATE 16 FEB 2011

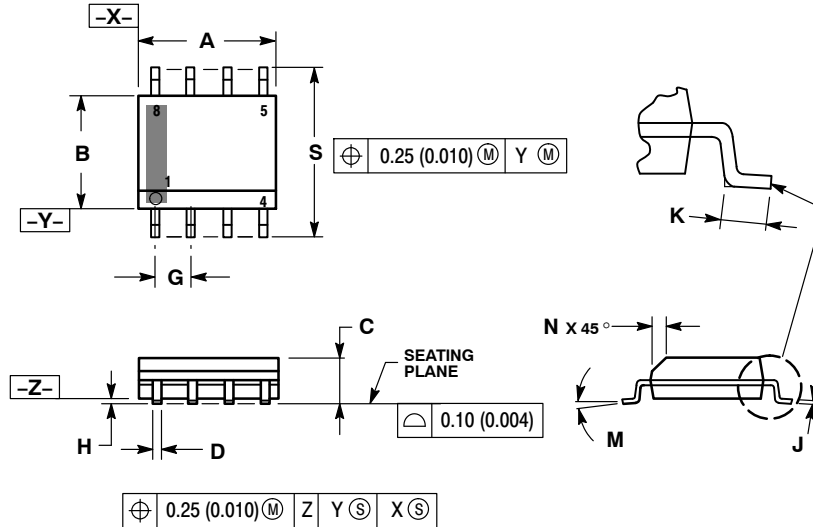

- NOTES:
1. DIMENSIONING AND TOLERANCING PER ANSI Y14.5M, 1982.
 2. CONTROLLING DIMENSION: MILLIMETER.
 3. DIMENSION A AND B DO NOT INCLUDE MOLD PROTRUSION.
 4. MAXIMUM MOLD PROTRUSION 0.15 (0.006) PER SIDE.
 5. DIMENSION D DOES NOT INCLUDE DAMBAR PROTRUSION. ALLOWABLE DAMBAR PROTRUSION SHALL BE 0.127 (0.005) TOTAL IN EXCESS OF THE D DIMENSION AT MAXIMUM MATERIAL CONDITION.
 6. 751-01 THRU 751-06 ARE OBSOLETE. NEW STANDARD IS 751-07.

DIM	MILLIMETERS		INCHES	
	MIN	MAX	MIN	MAX
A	4.80	5.00	0.189	0.197
B	3.80	4.00	0.150	0.157
C	1.35	1.75	0.053	0.069
D	0.33	0.51	0.013	0.020
G	1.27 BSC		0.050 BSC	
H	0.10	0.25	0.004	0.010
J	0.19	0.25	0.007	0.010
K	0.40	1.27	0.016	0.050
M	0°	8°	0°	8°
N	0.25	0.50	0.010	0.020
S	5.80	6.20	0.228	0.244

SOLDERING FOOTPRINT*

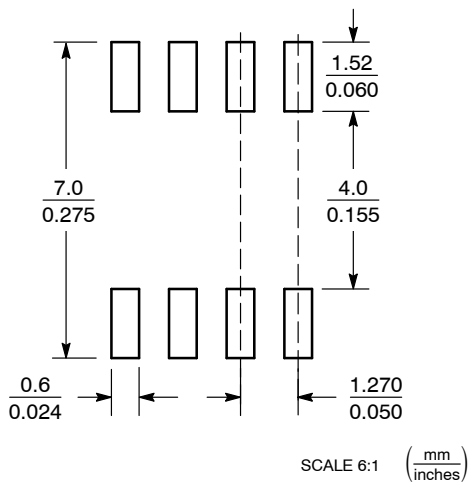

*For additional information on our Pb-Free strategy and soldering details, please download the ON Semiconductor Soldering and Mounting Techniques Reference Manual, SOLDERRM/D.

GENERIC MARKING DIAGRAM*

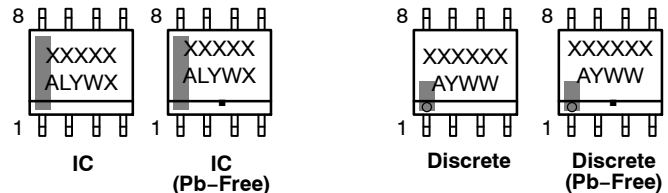

XXXXXX = Specific Device Code
A = Assembly Location
L = Wafer Lot
Y = Year
W = Work Week
▪ = Pb-Free Package

XXXXXX = Specific Device Code
A = Assembly Location
Y = Year
WW = Work Week
▪ = Pb-Free Package

*This information is generic. Please refer to device data sheet for actual part marking. Pb-Free indicator, "G" or microdot "▪", may or may not be present. Some products may not follow the Generic Marking.

STYLES ON PAGE 2

DOCUMENT NUMBER:	98ASB42564B	Electronic versions are uncontrolled except when accessed directly from the Document Repository. Printed versions are uncontrolled except when stamped "CONTROLLED COPY" in red.
DESCRIPTION:	SOIC-8 NB	PAGE 1 OF 2

onsemi and ONsemi are trademarks of Semiconductor Components Industries, LLC dba onsemi or its subsidiaries in the United States and/or other countries. onsemi reserves the right to make changes without further notice to any products herein. onsemi makes no warranty, representation or guarantee regarding the suitability of its products for any particular purpose, nor does onsemi assume any liability arising out of the application or use of any product or circuit, and specifically disclaims any and all liability, including without limitation special, consequential or incidental damages. onsemi does not convey any license under its patent rights nor the rights of others.

SOIC-8 NB
CASE 751-07
ISSUE AK

DATE 16 FEB 2011

- | | | | |
|---|--|--|--|
| <p>STYLE 1:
 PIN 1. EMITTER
 2. COLLECTOR
 3. COLLECTOR
 4. EMITTER
 5. EMITTER
 6. BASE
 7. BASE
 8. EMITTER</p> | <p>STYLE 2:
 PIN 1. COLLECTOR, DIE, #1
 2. COLLECTOR, #1
 3. COLLECTOR, #2
 4. COLLECTOR, #2
 5. BASE, #2
 6. EMITTER, #2
 7. BASE, #1
 8. EMITTER, #1</p> | <p>STYLE 3:
 PIN 1. DRAIN, DIE #1
 2. DRAIN, #1
 3. DRAIN, #2
 4. DRAIN, #2
 5. GATE, #2
 6. SOURCE, #2
 7. GATE, #1
 8. SOURCE, #1</p> | <p>STYLE 4:
 PIN 1. ANODE
 2. ANODE
 3. ANODE
 4. ANODE
 5. ANODE
 6. ANODE
 7. ANODE
 8. COMMON CATHODE</p> |
| <p>STYLE 5:
 PIN 1. DRAIN
 2. DRAIN
 3. DRAIN
 4. DRAIN
 5. GATE
 6. GATE
 7. SOURCE
 8. SOURCE</p> | <p>STYLE 6:
 PIN 1. SOURCE
 2. DRAIN
 3. DRAIN
 4. SOURCE
 5. SOURCE
 6. GATE
 7. GATE
 8. SOURCE</p> | <p>STYLE 7:
 PIN 1. INPUT
 2. EXTERNAL BYPASS
 3. THIRD STAGE SOURCE
 4. GROUND
 5. DRAIN
 6. GATE 3
 7. SECOND STAGE Vd
 8. FIRST STAGE Vd</p> | <p>STYLE 8:
 PIN 1. COLLECTOR, DIE #1
 2. BASE, #1
 3. BASE, #2
 4. COLLECTOR, #2
 5. COLLECTOR, #2
 6. EMITTER, #2
 7. EMITTER, #1
 8. COLLECTOR, #1</p> |
| <p>STYLE 9:
 PIN 1. EMITTER, COMMON
 2. COLLECTOR, DIE #1
 3. COLLECTOR, DIE #2
 4. EMITTER, COMMON
 5. EMITTER, COMMON
 6. BASE, DIE #2
 7. BASE, DIE #1
 8. EMITTER, COMMON</p> | <p>STYLE 10:
 PIN 1. GROUND
 2. BIAS 1
 3. OUTPUT
 4. GROUND
 5. GROUND
 6. BIAS 2
 7. INPUT
 8. GROUND</p> | <p>STYLE 11:
 PIN 1. SOURCE 1
 2. GATE 1
 3. SOURCE 2
 4. GATE 2
 5. DRAIN 2
 6. DRAIN 2
 7. DRAIN 1
 8. DRAIN 1</p> | <p>STYLE 12:
 PIN 1. SOURCE
 2. SOURCE
 3. SOURCE
 4. GATE
 5. DRAIN
 6. DRAIN
 7. DRAIN
 8. DRAIN</p> |
| <p>STYLE 13:
 PIN 1. N.C.
 2. SOURCE
 3. SOURCE
 4. GATE
 5. DRAIN
 6. DRAIN
 7. DRAIN
 8. DRAIN</p> | <p>STYLE 14:
 PIN 1. N-SOURCE
 2. N-GATE
 3. P-SOURCE
 4. P-GATE
 5. P-DRAIN
 6. P-DRAIN
 7. N-DRAIN
 8. N-DRAIN</p> | <p>STYLE 15:
 PIN 1. ANODE 1
 2. ANODE 1
 3. ANODE 1
 4. ANODE 1
 5. CATHODE, COMMON
 6. CATHODE, COMMON
 7. CATHODE, COMMON
 8. CATHODE, COMMON</p> | <p>STYLE 16:
 PIN 1. EMITTER, DIE #1
 2. BASE, DIE #1
 3. EMITTER, DIE #2
 4. BASE, DIE #2
 5. COLLECTOR, DIE #2
 6. COLLECTOR, DIE #2
 7. COLLECTOR, DIE #1
 8. COLLECTOR, DIE #1</p> |
| <p>STYLE 17:
 PIN 1. VCC
 2. V2OUT
 3. V1OUT
 4. TXE
 5. RXE
 6. VEE
 7. GND
 8. ACC</p> | <p>STYLE 18:
 PIN 1. ANODE
 2. ANODE
 3. SOURCE
 4. GATE
 5. DRAIN
 6. DRAIN
 7. CATHODE
 8. CATHODE</p> | <p>STYLE 19:
 PIN 1. SOURCE 1
 2. GATE 1
 3. SOURCE 2
 4. GATE 2
 5. DRAIN 2
 6. MIRROR 2
 7. DRAIN 1
 8. MIRROR 1</p> | <p>STYLE 20:
 PIN 1. SOURCE (N)
 2. GATE (N)
 3. SOURCE (P)
 4. GATE (P)
 5. DRAIN
 6. DRAIN
 7. DRAIN
 8. DRAIN</p> |
| <p>STYLE 21:
 PIN 1. CATHODE 1
 2. CATHODE 2
 3. CATHODE 3
 4. CATHODE 4
 5. CATHODE 5
 6. COMMON ANODE
 7. COMMON ANODE
 8. CATHODE 6</p> | <p>STYLE 22:
 PIN 1. I/O LINE 1
 2. COMMON CATHODE/VCC
 3. COMMON CATHODE/VCC
 4. I/O LINE 3
 5. COMMON ANODE/GND
 6. I/O LINE 4
 7. I/O LINE 5
 8. COMMON ANODE/GND</p> | <p>STYLE 23:
 PIN 1. LINE 1 IN
 2. COMMON ANODE/GND
 3. COMMON ANODE/GND
 4. LINE 2 IN
 5. LINE 2 OUT
 6. COMMON ANODE/GND
 7. COMMON ANODE/GND
 8. LINE 1 OUT</p> | <p>STYLE 24:
 PIN 1. BASE
 2. EMITTER
 3. COLLECTOR/ANODE
 4. COLLECTOR/ANODE
 5. CATHODE
 6. CATHODE
 7. COLLECTOR/ANODE
 8. COLLECTOR/ANODE</p> |
| <p>STYLE 25:
 PIN 1. VIN
 2. N/C
 3. REXT
 4. GND
 5. IOUT
 6. IOUT
 7. IOUT
 8. IOUT</p> | <p>STYLE 26:
 PIN 1. GND
 2. dv/dt
 3. ENABLE
 4. ILIMIT
 5. SOURCE
 6. SOURCE
 7. SOURCE
 8. VCC</p> | <p>STYLE 27:
 PIN 1. ILIMIT
 2. OVLO
 3. UVLO
 4. INPUT+
 5. SOURCE
 6. SOURCE
 7. SOURCE
 8. DRAIN</p> | <p>STYLE 28:
 PIN 1. SW_TO_GND
 2. DASIC_OFF
 3. DASIC_SW_DET
 4. GND
 5. V_MON
 6. VBULK
 7. VBULK
 8. VIN</p> |
| <p>STYLE 29:
 PIN 1. BASE, DIE #1
 2. EMITTER, #1
 3. BASE, #2
 4. EMITTER, #2
 5. COLLECTOR, #2
 6. COLLECTOR, #2
 7. COLLECTOR, #1
 8. COLLECTOR, #1</p> | <p>STYLE 30:
 PIN 1. DRAIN 1
 2. DRAIN 1
 3. GATE 2
 4. SOURCE 2
 5. SOURCE 1/DRAIN 2
 6. SOURCE 1/DRAIN 2
 7. SOURCE 1/DRAIN 2
 8. GATE 1</p> | | |

DOCUMENT NUMBER:	98ASB42564B	Electronic versions are uncontrolled except when accessed directly from the Document Repository. Printed versions are uncontrolled except when stamped "CONTROLLED COPY" in red.
DESCRIPTION:	SOIC-8 NB	PAGE 2 OF 2

onsemi and **ONSEMI** are trademarks of Semiconductor Components Industries, LLC dba **onsemi** or its subsidiaries in the United States and/or other countries. **onsemi** reserves the right to make changes without further notice to any products herein. **onsemi** makes no warranty, representation or guarantee regarding the suitability of its products for any particular purpose, nor does **onsemi** assume any liability arising out of the application or use of any product or circuit, and specifically disclaims any and all liability, including without limitation special, consequential or incidental damages. **onsemi** does not convey any license under its patent rights nor the rights of others.

MECHANICAL CASE OUTLINE

PACKAGE DIMENSIONS

ON Semiconductor®



SCALE 2:1

TSSOP 8 CASE 948R-02 ISSUE A

DATE 04/07/2000

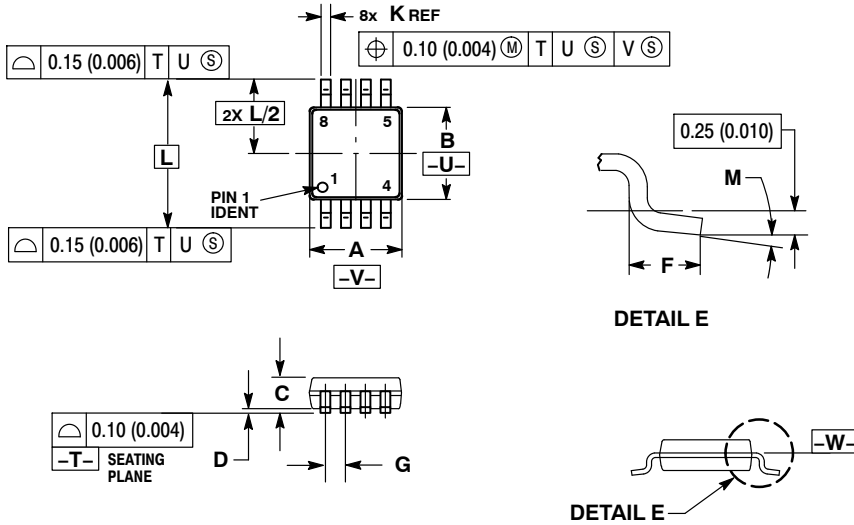

NOTES:

1. DIMENSIONING AND TOLERANCING PER ANSI Y14.5M, 1982.
2. CONTROLLING DIMENSION: MILLIMETER.
3. DIMENSION A DOES NOT INCLUDE MOLD FLASH, PROTRUSIONS OR GATE BURRS. MOLD FLASH OR GATE BURRS SHALL NOT EXCEED 0.15 (0.006) PER SIDE.
4. DIMENSION B DOES NOT INCLUDE INTERLEAD FLASH OR PROTRUSION. INTERLEAD FLASH OR PROTRUSION SHALL NOT EXCEED 0.25 (0.010) PER SIDE.
5. TERMINAL NUMBERS ARE SHOWN FOR REFERENCE ONLY.
6. DIMENSION A AND B ARE TO BE DETERMINED AT DATUM PLANE -V-.

DIM	MILLIMETERS		INCHES	
	MIN	MAX	MIN	MAX
A	2.90	3.10	0.114	0.122
B	2.90	3.10	0.114	0.122
C	0.80	1.10	0.031	0.043
D	0.05	0.15	0.002	0.006
F	0.40	0.70	0.016	0.028
G	0.65 BSC		0.026 BSC	
K	0.25	0.40	0.010	0.016
L	4.90 BSC		0.193 BSC	
M	0°	6°	0°	6°

DOCUMENT NUMBER:	98AON00236D	Electronic versions are uncontrolled except when accessed directly from the Document Repository. Printed versions are uncontrolled except when stamped "CONTROLLED COPY" in red.
DESCRIPTION:	TSSOP 8	PAGE 1 OF 1

ON Semiconductor and are trademarks of Semiconductor Components Industries, LLC dba ON Semiconductor or its subsidiaries in the United States and/or other countries. ON Semiconductor reserves the right to make changes without further notice to any products herein. ON Semiconductor makes no warranty, representation or guarantee regarding the suitability of its products for any particular purpose, nor does ON Semiconductor assume any liability arising out of the application or use of any product or circuit, and specifically disclaims any and all liability, including without limitation special, consequential or incidental damages. ON Semiconductor does not convey any license under its patent rights nor the rights of others.

onsemi, **Onsemi**, and other names, marks, and brands are registered and/or common law trademarks of Semiconductor Components Industries, LLC dba "**onsemi**" or its affiliates and/or subsidiaries in the United States and/or other countries. **onsemi** owns the rights to a number of patents, trademarks, copyrights, trade secrets, and other intellectual property. A listing of **onsemi**'s product/patent coverage may be accessed at www.onsemi.com/site/pdf/Patent-Marking.pdf. **onsemi** reserves the right to make changes at any time to any products or information herein, without notice. The information herein is provided "as-is" and **onsemi** makes no warranty, representation or guarantee regarding the accuracy of the information, product features, availability, functionality, or suitability of its products for any particular purpose, nor does **onsemi** assume any liability arising out of the application or use of any product or circuit, and specifically disclaims any and all liability, including without limitation special, consequential or incidental damages. Buyer is responsible for its products and applications using **onsemi** products, including compliance with all laws, regulations and safety requirements or standards, regardless of any support or applications information provided by **onsemi**. "Typical" parameters which may be provided in **onsemi** data sheets and/or specifications can and do vary in different applications and actual performance may vary over time. All operating parameters, including "Typicals" must be validated for each customer application by customer's technical experts. **onsemi** does not convey any license under any of its intellectual property rights nor the rights of others. **onsemi** products are not designed, intended, or authorized for use as a critical component in life support systems or any FDA Class 3 medical devices or medical devices with a same or similar classification in a foreign jurisdiction or any devices intended for implantation in the human body. Should Buyer purchase or use **onsemi** products for any such unintended or unauthorized application, Buyer shall indemnify and hold **onsemi** and its officers, employees, subsidiaries, affiliates, and distributors harmless against all claims, costs, damages, and expenses, and reasonable attorney fees arising out of, directly or indirectly, any claim of personal injury or death associated with such unintended or unauthorized use, even if such claim alleges that **onsemi** was negligent regarding the design or manufacture of the part. **onsemi** is an Equal Opportunity/Affirmative Action Employer. This literature is subject to all applicable copyright laws and is not for resale in any manner.

ADDITIONAL INFORMATION

TECHNICAL PUBLICATIONS:

Technical Library: www.onsemi.com/design/resources/technical-documentation
onsemi Website: www.onsemi.com

ONLINE SUPPORT: www.onsemi.com/support

For additional information, please contact your local Sales Representative at www.onsemi.com/support/sales

Looking for pricing, stock, or lifecycle information?

Click below to explore more details on WIN SOURCE:

 [View MC100EL1648DT](#) on WIN SOURCE

 [ON Semiconductor](#) Information

Optimize Your Supply Chain with WIN SOURCE Solutions

-  Global Sourcing Solution
-  Obsolete Management
-  Cost Control Management
-  Shortage Management
-  Alternative Solution
-  Excess Inventory Management