



**THE DATASHEET OF
MC100E416FNR2**



MC10E416, MC100E416

5V ECL Quint Differential Line Receiver

Description

The MC10E416/100E416 is a 5-bit differential line receiving device. The 2.0 GHz of bandwidth provided by the high frequency outputs makes the device ideal for buffering of very high speed oscillators.

The design incorporates two stages of gain, internal to the device, making it an excellent choice for use in high bandwidth amplifier applications.

The differential inputs have internal clamp structures which will force the Q output of a gate in an open input condition to go to a LOW state. Thus, inputs of unused gates can be left open and will not affect the operation of the rest of the device. Note that the input clamp will take affect only if both inputs fall 2.5 V below V_{CC} .

The V_{BB} pin, an internally generated voltage supply, is available to this device only. For single-ended input conditions, the unused differential input is connected to V_{BB} as a switching reference voltage. V_{BB} may also rebias AC coupled inputs. When used, decouple V_{BB} and V_{CC} via a 0.01 μ F capacitor and limit current sourcing or sinking to 0.5 mA. When not used, V_{BB} should be left open.

The 100 Series contains temperature compensation.

Features

- Differential D and Q; V_{BB} available
 - 600 ps Max. Propagation Delay
 - High Frequency Outputs
 - 2 Stages of Gain
 - PECL Mode Operating Range: $V_{CC} = 4.2$ V to 5.7 V with $V_{EE} = 0$ V
 - NECL Mode Operating Range: $V_{CC} = 0$ V with $V_{EE} = -4.2$ V to -5.7 V
 - Internal Input 50 k Ω Pulldown Resistors
 - ESD Protection: Human Body Model; > 2 kV, Machine Model; > 200 V
 - Meets or Exceeds JEDEC Spec EIA/JESD78 IC Latchup Test
 - Moisture Sensitivity Level:
 - Pb = 1;
 - Pb-Free = 3
- For Additional Information, see Application Note AND8003/D
- Flammability Rating: UL 94 V-0 @ 0.125 in, Oxygen Index: 28 to 34
 - Transistor Count = 201 devices
 - Pb-Free Packages are Available*

*For additional information on our Pb-Free strategy and soldering details, please download the ON Semiconductor Soldering and Mounting Techniques Reference Manual, SOLDERRM/D.



ON Semiconductor®

<http://onsemi.com>

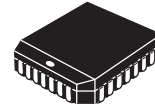

PLCC-28
FN SUFFIX
CASE 776

MARKING DIAGRAM*

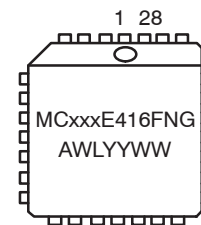

| | |
|-----|---------------------|
| xxx | = 10 or 100 |
| A | = Assembly Location |
| WL | = Wafer Lot |
| YY | = Year |
| WW | = Work Week |
| G | = Pb-Free Package |

*For additional marking information, refer to Application Note AND8002/D.

ORDERING INFORMATION

See detailed ordering and shipping information in the package dimensions section on page 7 of this data sheet.

MC10E416, MC100E416

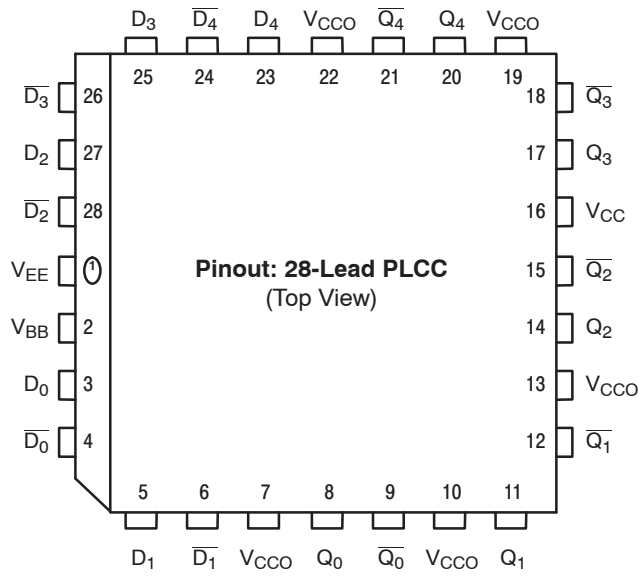

* All V_{CC} and V_{CCO} pins are tied together on the die.
 Warning: All V_{CC} , V_{CCO} , and V_{EE} pins must be externally connected to Power Supply to guarantee proper operation.

Figure 1. 28-Lead Pinout Assignment

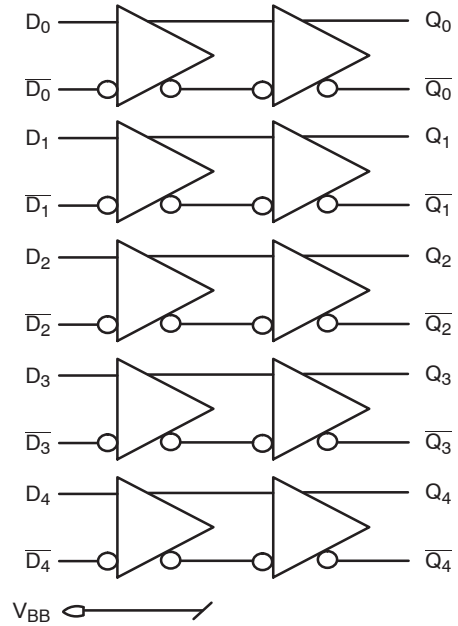

Figure 2. Logic Diagram

Table 1. PIN DESCRIPTION

| PIN | FUNCTION |
|-------------------------|-------------------------------|
| D[0:4], \bar{D} [0:4] | ECL Differential Data Inputs |
| Q[0:4], \bar{Q} [0:4] | ECL Differential Data Outputs |
| V_{BB} | Reference Voltage Output |
| V_{CC} , V_{CCO} | Positive Supply |
| V_{EE} | Negative Supply |

MC10E416, MC100E416

Table 2. MAXIMUM RATINGS

| Symbol | Parameter | Condition 1 | Condition 2 | Rating | Unit |
|---------------|--|--|--|--------------|--|
| V_{CC} | PECL Mode Power Supply | $V_{EE} = 0\text{ V}$ | | 8 | V |
| V_I | PECL Mode Input Voltage NECL Mode Input Voltage | $V_{EE} = 0\text{ V}$ $V_{CC} = 0\text{ V}$ | $V_I \leq V_{CC}$ $V_I \geq V_{EE}$ | 6 -6 | V V |
| I_{out} | Output Current | Continuous Surge | | 50 100 | mA mA |
| I_{BB} | V_{BB} Sink/Source | | | ± 0.5 | mA |
| T_A | Operating Temperature Range | | | 0 to +85 | $^{\circ}\text{C}$ |
| T_{stg} | Storage Temperature Range | | | -65 to +150 | $^{\circ}\text{C}$ |
| θ_{JA} | Thermal Resistance (Junction-to-Ambient) | 0 lfpm 500 lfpm | PLCC-28 PLCC-28 | 63.5 43.5 | $^{\circ}\text{C}/\text{W}$ $^{\circ}\text{C}/\text{W}$ |
| θ_{JC} | Thermal Resistance (Junction-to-Case) | Standard Board | PLCC-28 | 22 to 26 | $^{\circ}\text{C}/\text{W}$ |
| T_{sol} | Wave Solder Pb Pb-Free | | | 265 265 | $^{\circ}\text{C}$ |

Stresses exceeding Maximum Ratings may damage the device. Maximum Ratings are stress ratings only. Functional operation above the Recommended Operating Conditions is not implied. Extended exposure to stresses above the Recommended Operating Conditions may affect device reliability.

MC10E416, MC100E416

Table 3. 10E SERIES PECL DC CHARACTERISTICS $V_{CCx} = 5.0\text{ V}$, $V_{EE} = 0.0\text{ V}$ (Note 1)

| Symbol | Characteristic | 0°C | | | 25°C | | | 85°C | | | Unit |
|-------------|--|------|------|------|------|------|------|------|------|------|---------------|
| | | Min | Typ | Max | Min | Typ | Max | Min | Typ | Max | |
| I_{EE} | Power Supply Current | | 135 | 162 | | 135 | 162 | | 135 | 162 | mA |
| V_{OH} | Output HIGH Voltage (Note 2) | 3980 | 4070 | 4160 | 4020 | 4105 | 4190 | 4090 | 4185 | 4280 | mV |
| V_{OL} | Output LOW Voltage (Note 2) | 3050 | 3210 | 3370 | 3050 | 3210 | 3370 | 3050 | 3227 | 3405 | mV |
| V_{IH} | Input HIGH Voltage (Single-Ended) | 3830 | 3995 | 4160 | 3870 | 4030 | 4190 | 3940 | 4110 | 4280 | mV |
| V_{IL} | Input LOW Voltage (Single-Ended) | 3050 | 3285 | 3520 | 3050 | 3285 | 3520 | 3050 | 3302 | 3555 | mV |
| V_{BB} | Output Voltage Reference | 3.62 | | 3.73 | 3.65 | | 3.75 | 3.69 | | 3.81 | V |
| V_{IHCMR} | Input HIGH Voltage Common Mode Range (Differential Configuration) (Note 3) | 2.7 | | 5.0 | 2.7 | | 5.0 | 2.7 | | 5.0 | V |
| I_{IH} | Input HIGH Current | | | 150 | | | 150 | | | 150 | μA |
| I_{IL} | Input LOW Current | 0.5 | 0.3 | | 0.5 | 0.25 | | 0.3 | 0.2 | | μA |

NOTE: Device will meet the specifications after thermal equilibrium has been established when mounted in a test socket or printed circuit board with maintained transverse airflow greater than 500 lfm. Electrical parameters are guaranteed only over the declared operating temperature range. Functional operation of the device exceeding these conditions is not implied. Device specification limit values are applied individually under normal operating conditions and not valid simultaneously.

1. Input and output parameters vary 1:1 with V_{CC} . V_{EE} can vary $-0.46\text{ V} / +0.06\text{ V}$.
2. Outputs are terminated through a $50\ \Omega$ resistor to $V_{CC} - 2.0\text{ V}$.
3. V_{IHCMR} min varies 1:1 with V_{EE} , max varies 1:1 with V_{CC} .

Table 4. 10E SERIES NECL DC CHARACTERISTICS $V_{CCx} = 0.0\text{ V}$; $V_{EE} = -5.0\text{ V}$ (Note 4)

| Symbol | Characteristic | 0°C | | | 25°C | | | 85°C | | | Unit |
|-------------|--|-------|-------|-------|-------|-------|-------|-------|-------|-------|---------------|
| | | Min | Typ | Max | Min | Typ | Max | Min | Typ | Max | |
| I_{EE} | Power Supply Current | | 135 | 162 | | 135 | 162 | | 135 | 162 | mA |
| V_{OH} | Output HIGH Voltage (Note 5) | -1020 | -930 | -840 | -980 | -895 | -810 | -910 | -815 | -720 | mV |
| V_{OL} | Output LOW Voltage (Note 5) | -1950 | -1790 | -1630 | -1950 | -1790 | -1630 | -1950 | -1773 | -1595 | mV |
| V_{IH} | Input HIGH Voltage (Single-Ended) | -1170 | -1005 | -840 | -1130 | -970 | -810 | -1060 | -890 | -720 | mV |
| V_{IL} | Input LOW Voltage (Single-Ended) | -1950 | -1715 | -1480 | -1950 | -1715 | -1480 | -1950 | -1698 | -1445 | mV |
| V_{BB} | Output Voltage Reference | -1.38 | | -1.27 | -1.35 | | -1.25 | -1.31 | | -1.19 | V |
| V_{IHCMR} | Input HIGH Voltage Common Mode Range (Differential Configuration) (Note 6) | -2.3 | | 0.0 | -2.3 | | 0.0 | -2.3 | | 0.0 | V |
| I_{IH} | Input HIGH Current | | | 150 | | | 150 | | | 150 | μA |
| I_{IL} | Input LOW Current | 0.5 | 0.3 | | 0.5 | 0.065 | | 0.3 | 0.2 | | μA |

NOTE: Device will meet the specifications after thermal equilibrium has been established when mounted in a test socket or printed circuit board with maintained transverse airflow greater than 500 lfm. Electrical parameters are guaranteed only over the declared operating temperature range. Functional operation of the device exceeding these conditions is not implied. Device specification limit values are applied individually under normal operating conditions and not valid simultaneously.

4. Input and output parameters vary 1:1 with V_{CC} . V_{EE} can vary $-0.46\text{ V} / +0.06\text{ V}$.
5. Outputs are terminated through a $50\ \Omega$ resistor to $V_{CC} - 2.0\text{ V}$.
6. V_{IHCMR} min varies 1:1 with V_{EE} , max varies 1:1 with V_{CC} .

MC10E416, MC100E416

Table 5. 100E SERIES PECL DC CHARACTERISTICS $V_{CCx} = 5.0\text{ V}$; $V_{EE} = 0.0\text{ V}$ (Note 7)

| Symbol | Characteristic | 0°C | | | 25°C | | | 85°C | | | Unit |
|-------------|--|------|------|------|------|------|------|------|------|------|---------------|
| | | Min | Typ | Max | Min | Typ | Max | Min | Typ | Max | |
| I_{EE} | Power Supply Current | | 135 | 162 | | 135 | 162 | | 155 | 186 | mA |
| V_{OH} | Output HIGH Voltage (Note 8) | 3975 | 4050 | 4120 | 3975 | 4050 | 4120 | 3975 | 4050 | 4120 | mV |
| V_{OL} | Output LOW Voltage (Note 8) | 3190 | 3295 | 3380 | 3190 | 3255 | 3380 | 3190 | 3260 | 3380 | mV |
| V_{IH} | Input HIGH Voltage (Single-Ended) | 3835 | 3975 | 4120 | 3835 | 3975 | 4120 | 3835 | 3975 | 4120 | mV |
| V_{IL} | Input LOW Voltage (Single-Ended) | 3190 | 3355 | 3525 | 3190 | 3355 | 3525 | 3190 | 3355 | 3525 | mV |
| V_{BB} | Output Voltage Reference | 3.62 | | 3.74 | 3.62 | | 3.74 | 3.62 | | 3.74 | V |
| V_{IHCMR} | Input HIGH Voltage Common Mode Range (Differential Configuration) (Note 9) | 2.7 | | 5.0 | 2.7 | | 5.0 | 2.7 | | 5.0 | V |
| I_{IH} | Input HIGH Current | | | 150 | | | 150 | | | 150 | μA |
| I_{IL} | Input LOW Current | 0.5 | 0.3 | | 0.5 | 0.25 | | 0.5 | 0.2 | | μA |

NOTE: Device will meet the specifications after thermal equilibrium has been established when mounted in a test socket or printed circuit board with maintained transverse airflow greater than 500 lfm. Electrical parameters are guaranteed only over the declared operating temperature range. Functional operation of the device exceeding these conditions is not implied. Device specification limit values are applied individually under normal operating conditions and not valid simultaneously.

7. Input and output parameters vary 1:1 with V_{CC} . V_{EE} can vary $-0.46\text{ V} / +0.8\text{ V}$.

8. Outputs are terminated through a $50\ \Omega$ resistor to $V_{CC} - 2.0\text{ V}$.

9. V_{IHCMR} min varies 1:1 with V_{EE} , max varies 1:1 with V_{CC} .

Table 6. 100E SERIES NECL DC CHARACTERISTICS $V_{CCx} = 0\text{ V}$; $V_{EE} = -5.0\text{ V}$ (Note 10)

| Symbol | Characteristic | 0°C | | | 25°C | | | 85°C | | | Unit |
|-------------|---|-------|-------|-------|-------|-------|-------|-------|-------|-------|---------------|
| | | Min | Typ | Max | Min | Typ | Max | Min | Typ | Max | |
| I_{EE} | Power Supply Current | | 135 | 162 | | 135 | 162 | | 155 | 186 | mA |
| V_{OH} | Output HIGH Voltage (Note 11) | -1025 | -950 | -880 | -1025 | -950 | -880 | -1025 | -950 | -880 | mV |
| V_{OL} | Output LOW Voltage (Note 11) | -1810 | -1705 | -1620 | -1810 | -1745 | -1620 | -1810 | -1740 | -1620 | mV |
| V_{IH} | Input HIGH Voltage (Single-Ended) | -1165 | -1025 | -880 | -1165 | -1025 | -880 | -1165 | -1025 | -880 | mV |
| V_{IL} | Input LOW Voltage (Single-Ended) | -1810 | -1645 | -1475 | -1810 | -1645 | -1475 | -1810 | -1645 | -1475 | mV |
| V_{BB} | Output Voltage Reference | -1.38 | | -1.26 | -1.38 | | -1.26 | -1.38 | | -1.26 | V |
| V_{IHCMR} | Input HIGH Voltage Common Mode Range (Differential Configuration) (Note 12) | -2.3 | | 0.0 | -2.3 | | 0.0 | -2.3 | | 0.0 | V |
| I_{IH} | Input HIGH Current | | | 150 | | | 150 | | | 150 | μA |
| I_{IL} | Input LOW Current | 0.5 | 0.3 | | 0.5 | 0.25 | | 0.5 | 0.2 | | μA |

NOTE: Device will meet the specifications after thermal equilibrium has been established when mounted in a test socket or printed circuit board with maintained transverse airflow greater than 500 lfm. Electrical parameters are guaranteed only over the declared operating temperature range. Functional operation of the device exceeding these conditions is not implied. Device specification limit values are applied individually under normal operating conditions and not valid simultaneously.

10. Input and output parameters vary 1:1 with V_{CC} . V_{EE} can vary $-0.46\text{ V} / +0.8\text{ V}$.

11. Outputs are terminated through a $50\ \Omega$ resistor to $V_{CC} - 2.0\text{ V}$.

12. V_{IHCMR} min varies 1:1 with V_{EE} , max varies 1:1 with V_{CC} .

MC10E416, MC100E416

Table 7. AC CHARACTERISTICS $V_{CCx} = 5.0\text{ V}$; $V_{EE} = 0.0\text{ V}$ or $V_{CCx} = 0.0\text{ V}$; $V_{EE} = -5.0\text{ V}$ (Note 13)

| Symbol | Characteristic | 0°C | | | 25°C | | | 85°C | | | Unit |
|------------------------|---|-----|----------|------|------|----------|------|------|----------|------|------|
| | | Min | Typ | Max | Min | Typ | Max | Min | Typ | Max | |
| f_{MAX} | Maximum Toggle Frequency | | | | | > 2.0 | | | | | GHz |
| t_{PLH} t_{PHL} | Propagation Delay to Output | | | | | | | | | | ps |
| | d(Diff) | 250 | 350 | 500 | 250 | 350 | 500 | 250 | 350 | 500 | |
| | D(SE) | 200 | 350 | 550 | 200 | 350 | 550 | 200 | 350 | 550 | |
| t_{SKEW} | Within-Device Skew (Note 14) | | 50 | | | 50 | | | 50 | | ps |
| t_{SKEW} | Duty Cycle Skew (Note 15) $t_{PLH}-t_{PHL}$ | | ± 10 | | | ± 10 | | | ± 10 | | ps |
| t_{JITTER} | Random Clock Jitter (RMS) | | < 1 | | | < 1 | | | < 1 | | ps |
| $V_{PP(AC)}$ | Input Voltage Swing (Differential Configuration) | 150 | | 1000 | 150 | | 1000 | 150 | | 1000 | mV |
| t_r t_f | Rise/Fall Time (20 - 80%) | 100 | 200 | 350 | 100 | 200 | 350 | 100 | 200 | 350 | ps |

NOTE: Device will meet the specifications after thermal equilibrium has been established when mounted in a test socket or printed circuit board with maintained transverse airflow greater than 500 lfpm. Electrical parameters are guaranteed only over the declared operating temperature range. Functional operation of the device exceeding these conditions is not implied. Device specification limit values are applied individually under normal operating conditions and not valid simultaneously.

13. 10 Series: V_{EE} can vary $-0.46\text{ V} / +0.06\text{ V}$.

100 Series: V_{EE} can vary $-0.46\text{ V} / +0.8\text{ V}$.

14. Within-device skew is defined as identical transitions on similar paths through a device.

15. Duty cycle skew defined only for differential operation when the delays are measured from the cross point of the inputs to the cross point of the outputs.

MC10E416, MC100E416

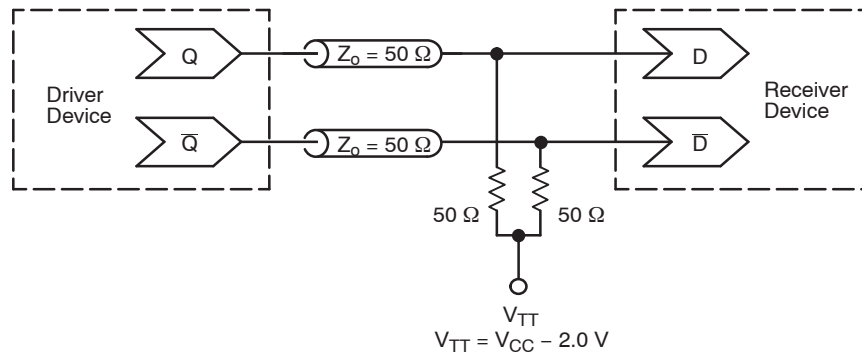

**Figure 3. Typical Termination for Output Driver and Device Evaluation
(See Application Note AND8020/D – Termination of ECL Logic Devices.)**

ORDERING INFORMATION

| Device | Package | Shipping [†] |
|----------------|----------------------|-----------------------|
| MC10E416FN | PLCC-28 | 37 Units / Rail |
| MC10E416FNG | PLCC-28 (Pb-Free) | 37 Units / Rail |
| MC10E416FNR2 | PLCC-28 | 500 / Tape & Reel |
| MC10E416FNR2G | PLCC-28 (Pb-Free) | 500 / Tape & Reel |
| MC100E416FN | PLCC-28 | 37 Units / Rail |
| MC100E416FNG | PLCC-28 (Pb-Free) | 37 Units / Rail |
| MC100E416FNR2 | PLCC-28 | 500 / Tape & Reel |
| MC100E416FNR2G | PLCC-28 (Pb-Free) | 500 / Tape & Reel |

[†]For information on tape and reel specifications, including part orientation and tape sizes, please refer to our Tape and Reel Packaging Specifications Brochure, BRD8011/D.

Resource Reference of Application Notes

- AN1405/D** – ECL Clock Distribution Techniques
- AN1406/D** – Designing with PECL (ECL at +5.0 V)
- AN1503/D** – ECLinPS™ I/O SPICE Modeling Kit
- AN1504/D** – Metastability and the ECLinPS Family
- AN1568/D** – Interfacing Between LVDS and ECL
- AN1672/D** – The ECL Translator Guide
- AND8001/D** – Odd Number Counters Design
- AND8002/D** – Marking and Date Codes
- AND8020/D** – Termination of ECL Logic Devices
- AND8066/D** – Interfacing with ECLinPS
- AND8090/D** – AC Characteristics of ECL Devices

MC10E416, MC100E416

PACKAGE DIMENSIONS

PLCC-28
FN SUFFIX
PLASTIC PLCC PACKAGE
CASE 776-02
ISSUE E

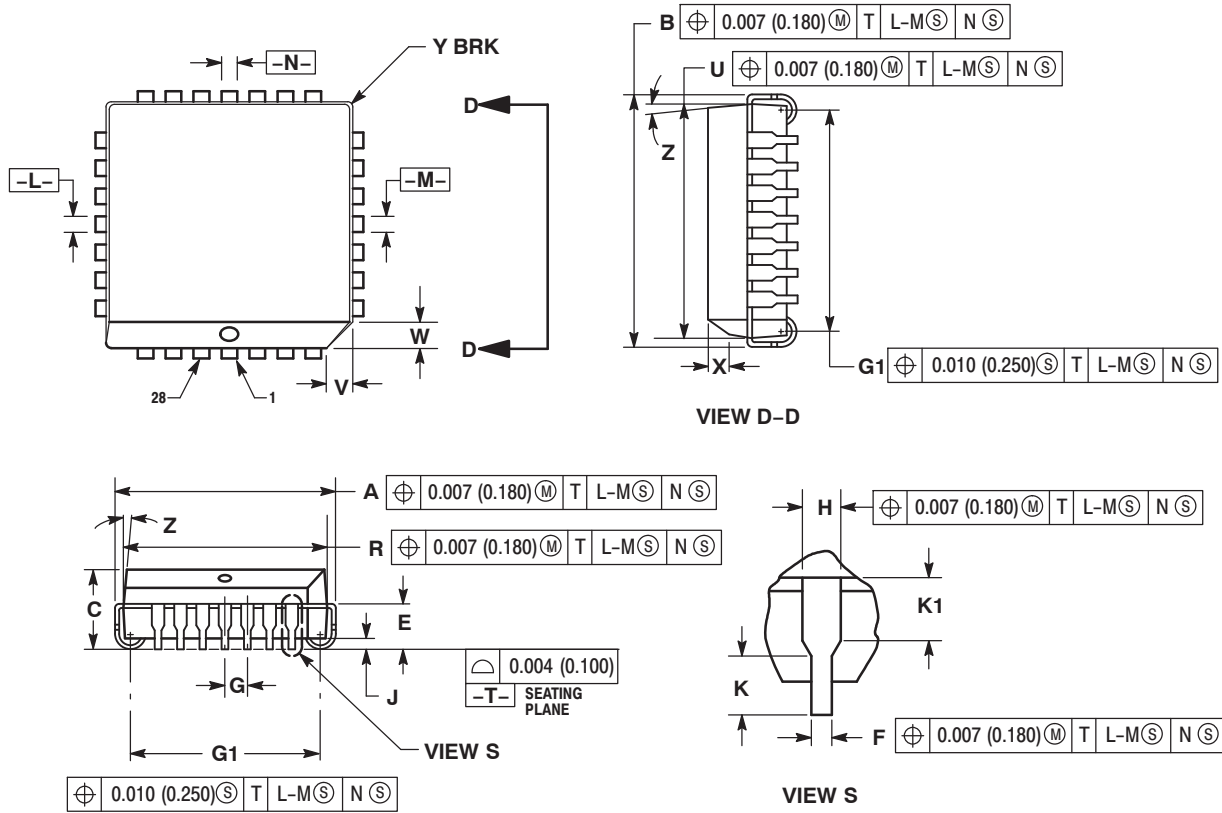

NOTES:

- DATUMS $-L-$, $-M-$, AND $-N-$ DETERMINED WHERE TOP OF LEAD SHOULDER EXITS PLASTIC BODY AT MOLD PARTING LINE.
- DIMENSION $G1$, TRUE POSITION TO BE MEASURED AT DATUM $-T-$, SEATING PLANE.
- DIMENSIONS R AND U DO NOT INCLUDE MOLD FLASH. ALLOWABLE MOLD FLASH IS 0.010 (0.250) PER SIDE.
- DIMENSIONING AND TOLERANCING PER ANSI Y14.5M, 1982.
- CONTROLLING DIMENSION: INCH.
- THE PACKAGE BOTTOM MAY BE SMALLER THAN THE PACKAGE TOP BY UP TO 0.012 (0.300). DIMENSIONS R AND U ARE DETERMINED AT THE OUTERMOST EXTREMES OF THE PLASTIC BODY EXCLUSIVE OF MOLD FLASH, TIE BAR BURRS, GATE BURRS AND INTERLEAD FLASH, BUT INCLUDING ANY MISMATCH BETWEEN THE TOP AND BOTTOM OF THE PLASTIC BODY.
- DIMENSION H DOES NOT INCLUDE DAMBAR PROTRUSION OR INTRUSION. THE DAMBAR PROTRUSION(S) SHALL NOT CAUSE THE H DIMENSION TO BE GREATER THAN 0.037 (0.940). THE DAMBAR INTRUSION(S) SHALL NOT CAUSE THE H DIMENSION TO BE SMALLER THAN 0.025 (0.635).

| DIM | INCHES | | MILLIMETERS | |
|-----|-----------|-------|-------------|-------|
| | MIN | MAX | MIN | MAX |
| A | 0.485 | 0.495 | 12.32 | 12.57 |
| B | 0.485 | 0.495 | 12.32 | 12.57 |
| C | 0.165 | 0.180 | 4.20 | 4.57 |
| E | 0.090 | 0.110 | 2.29 | 2.79 |
| F | 0.013 | 0.019 | 0.33 | 0.48 |
| G | 0.050 BSC | | 1.27 BSC | |
| H | 0.026 | 0.032 | 0.66 | 0.81 |
| J | 0.020 | --- | 0.51 | --- |
| K | 0.025 | --- | 0.64 | --- |
| R | 0.450 | 0.456 | 11.43 | 11.58 |
| U | 0.450 | 0.456 | 11.43 | 11.58 |
| V | 0.042 | 0.048 | 1.07 | 1.21 |
| W | 0.042 | 0.048 | 1.07 | 1.21 |
| X | 0.042 | 0.056 | 1.07 | 1.42 |
| Y | --- | 0.020 | --- | 0.50 |
| Z | 2° | | 10° | |
| G1 | 0.410 | 0.430 | 10.42 | 10.92 |
| K1 | 0.040 | --- | 1.02 | --- |

MC10E416, MC100E416

ECLinPS is a trademark of Semiconductor Components Industries, LLC (SCILLC).

ON Semiconductor and **ON** are registered trademarks of Semiconductor Components Industries, LLC (SCILLC). SCILLC reserves the right to make changes without further notice to any products herein. SCILLC makes no warranty, representation or guarantee regarding the suitability of its products for any particular purpose, nor does SCILLC assume any liability arising out of the application or use of any product or circuit, and specifically disclaims any and all liability, including without limitation special, consequential or incidental damages. "Typical" parameters which may be provided in SCILLC data sheets and/or specifications can and do vary in different applications and actual performance may vary over time. All operating parameters, including "Typicals" must be validated for each customer application by customer's technical experts. SCILLC does not convey any license under its patent rights nor the rights of others. SCILLC products are not designed, intended, or authorized for use as components in systems intended for surgical implant into the body, or other applications intended to support or sustain life, or for any other application in which the failure of the SCILLC product could create a situation where personal injury or death may occur. Should Buyer purchase or use SCILLC products for any such unintended or unauthorized application, Buyer shall indemnify and hold SCILLC and its officers, employees, subsidiaries, affiliates, and distributors harmless against all claims, costs, damages, and expenses, and reasonable attorney fees arising out of, directly or indirectly, any claim of personal injury or death associated with such unintended or unauthorized use, even if such claim alleges that SCILLC was negligent regarding the design or manufacture of the part. SCILLC is an Equal Opportunity/Affirmative Action Employer. This literature is subject to all applicable copyright laws and is not for resale in any manner.

PUBLICATION ORDERING INFORMATION

LITERATURE FULFILLMENT:

Literature Distribution Center for ON Semiconductor
P.O. Box 5163, Denver, Colorado 80217 USA
Phone: 303-675-2175 or 800-344-3860 Toll Free USA/Canada
Fax: 303-675-2176 or 800-344-3867 Toll Free USA/Canada
Email: orderlit@onsemi.com

N. American Technical Support: 800-282-9855 Toll Free
USA/Canada
Europe, Middle East and Africa Technical Support:
Phone: 421 33 790 2910
Japan Customer Focus Center
Phone: 81-3-5773-3850

ON Semiconductor Website: www.onsemi.com
Order Literature: <http://www.onsemi.com/orderlit>

For additional information, please contact your local
Sales Representative

Looking for pricing, stock, or lifecycle information?

Click below to explore more details on WIN SOURCE:

- ⊖ [View MC100E416FNR2 on WIN SOURCE](#)
- ⊖ [ON Semiconductor Information](#)

Optimize Your Supply Chain with WIN SOURCE Solutions

- ✓ Global Sourcing Solution
- ✓ Obsolete Management
- ✓ Cost Control Management
- ✓ Shortage Management
- ✓ Alternative Solution
- ✓ Excess Inventory Management