



**THE DATASHEET OF  
TS5V330CPWR**



## QUAD SPDT WIDE BANDWIDTH VIDEO SWITCH WITH LOW ON-STATE RESISTANCE

Check for Samples: [TS5V330C](#)

### FEATURES

- **Low Differential Gain and Phase**  
(Typical  $D_G = 0.24\%$ , Typical  $D_P = 0.039^\circ$ )
- **Wide Bandwidth** (Typical  $BW > 288$  MHz)
- **Low Cross-Talk** (Typical  $X_{TALK} = -87$  dB)
- **Low Power Consumption**  
(Maximum  $I_{CC} = 3$   $\mu$ A)
- **Bidirectional Data Flow, With Near-Zero Propagation Delay**
- **Low ON-State Resistance** (Typical  $r_{ON} = 3$   $\Omega$ )
- **$V_{CC}$  Operating Range From 4.5 V to 5.5 V**
- **$I_{off}$  Supports Partial-Power-Down Mode Operation**
- **Data and Control Inputs Provide Undershoot Clamp Diode**
- **Control Inputs Can be Driven by TTL or 5-V/3.3-V CMOS Outputs**
- **Latch-Up Performance Exceeds 100 mA Per JESD 78, Class II**
- **ESD Performance Tested Per JESD 22**
  - 2000-V Human-Body Model (A114-B, Class II)
  - 1000-V Charged-Device Model (C101)
- **Suitable for Both RGB and Composite Video Switching**

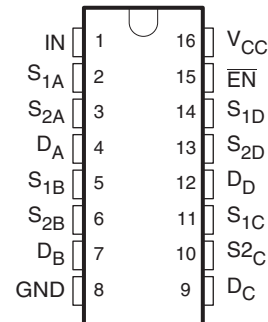
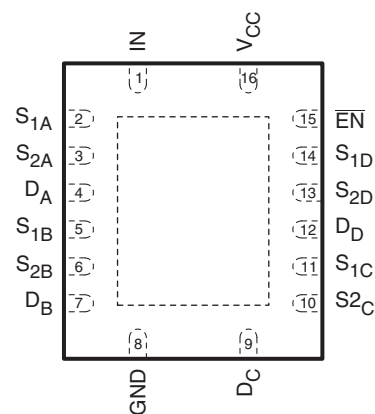
**D, DB, DBQ, OR PW PACKAGE  
(TOP VIEW)**

**RGY PACKAGE  
(TOP VIEW)**

### DESCRIPTION/ORDERING INFORMATION

The TS5V330C is a 4-bit 1-of-2 multiplexer/demultiplexer video switch with a single switch-enable ( $\overline{EN}$ ) input. The select (IN) input controls the data path of the multiplexer/demultiplexer. When  $\overline{EN}$  is low, the switch is enabled and the D port is connected to the S port. When  $\overline{EN}$  is high, the switch is disabled and a high impedance state exists between the D and S ports.

Low differential gain and phase makes this switch ideal for video applications. The device has a wide bandwidth and low cross talk which makes it suitable for high frequency video applications. The device can be used for RGB and composite video switching applications.

This device is fully specified for partial-power-down applications using  $I_{off}$ . The  $I_{off}$  feature ensures that damaging current will not backflow through the device when it is powered down. The device has isolation during power off.

To ensure the high-impedance state during power up or power down,  $\overline{EN}$  should be tied to  $V_{CC}$  through a pullup resistor; the minimum value of the resistor is determined by the current-sinking capability of the driver.



Please be aware that an important notice concerning availability, standard warranty, and use in critical applications of Texas Instruments semiconductor products and disclaimers thereto appears at the end of this data sheet.

**ORDERING INFORMATION**

T <sub>A</sub>	PACKAGE <sup>(1)</sup> (2)		ORDERABLE PART NUMBER	TOP-SIDE MARKING
–40°C to 85°C	QFN – RGY	Tape and reel	TS5V330CRGYR	TE330C
	SOIC – D	Tube	TS5V330CD	TS5V330C
		Tape and reel	TS5V330CDR	
	SSOP – DB	Tape and reel	TS5V330CDBR	TE330C
	SSOP (QSOP) – DBQ	Tape and reel	TS5V330CDBQR	TE330C
	TSSOP – PW	Tube	TS5V330CPW	TE330C
		Tape and reel	TS5V330CPWR	

(1) Package drawings, thermal data, and symbolization are available at [www.ti.com/packaging](http://www.ti.com/packaging).

(2) For the most current package and ordering information, see the Package Option Addendum at the end of this document, or see the TI website at [www.ti.com](http://www.ti.com).

**Table 1. FUNCTION TABLE**

INPUTS		INPUT/OUTPUT A	FUNCTION
$\overline{\text{EN}}$	IN		
L	L	S1	D port = S1 port
L	H	S2	D port = S2 port
H	X	Z	Disconnect

**Table 2. PIN DESCRIPTIONS**

PIN NAME	DESCRIPTION
S1, S2	Analog video I/Os
D	Analog video I/Os
IN	Select input
$\overline{\text{EN}}$	Switch-enable input

**PARAMETER DEFINITIONS**

PARAMETER	DESCRIPTION
$r_{ON}$	Resistance between the D and S ports with the switch in the ON-state
$I_{OZ}$	Output leakage current measured at the D and S ports with the switch in the OFF-state
$I_{OS}$	Short circuit current measured at the I/O pins.
$V_{IN}$	Voltage at the IN pin
$V_{EN}$	Voltage at the $\overline{EN}$ pin
$C_{IN}$	Capacitance at the control inputs ( $\overline{EN}$ , IN)
$C_{OFF}$	Capacitance at the analog I/O port when the switch is OFF
$C_{ON}$	Capacitance at the analog I/O port when the switch is ON
$V_{IH}$	Minimum input voltage for logic high for the control inputs ( $\overline{EN}$ , IN)
$V_{IL}$	Minimum input voltage for logic low for the control inputs ( $\overline{EN}$ , IN)
$V_H$	Hysteresis voltage at the control inputs ( $\overline{EN}$ , IN)
$V_{IK}$	I/O and control inputs diode clamp voltage ( $\overline{EN}$ , IN)
$V_I$	Voltage applied to the D or S pins when D or S is the switch input.
$V_O$	Voltage applied to the D or S pins when D or S is the switch output.
$I_{IH}$	Input high leakage current of the control inputs ( $\overline{EN}$ , IN)
$I_{IL}$	Input low leakage current of the control inputs ( $\overline{EN}$ , IN)
$I_I$	Current into the D or S pins when D or S is the switch input.
$I_O$	Current into the D or S pins when D or S is the switch output.
$I_{off}$	Output leakage current measured at the D and S ports with $V_{CC} = 0$
$t_{ON}$	Propagation delay measured between 50% of the digital input to 90% of the analog output when switch is turned ON.
$t_{OFF}$	Propagation delay measured between 50% of the digital input to 90% of the analog output when switch is turned OFF.
BW	Frequency response of the switch in the ON-state measured at –3 dB
$X_{TALK}$	Unwanted signal coupled from channel to channel. Measured in –dB. $X_{TALK} = 20 \text{ LOG } V_{OUT}/V_{IN}$ . This is a non-adjacent crosstalk.
$O_{IRR}$	Off-isolation is the resistance (measured in –dB) between the input and output with the switch OFF.
$D_G$	Magnitude variation between analog input and output pins when the switch is ON and the DC offset of composite video signal varies at the analog input pin. In NTSC standard the frequency of the video signal is 3.58 MHz and DC offset is from 0 to 0.714 V.
$D_P$	Phase variation between analog input and output pins when the switch is ON and the DC offset of composite video signal varies at the analog input pin. In NTSC standard the frequency of the video signal is 3.58 MHz and DC offset is from 0 to 0.714 V.
$I_{CC}$	Static power supply current
$I_{CCD}$	Variation of $I_{CC}$ for a change in frequency in the control inputs ( $\overline{EN}$ , IN)
$\Delta I_{CC}$	This is the increase in supply current for each control input that is at the specified voltage level, rather than $V_{CC}$ or GND.

**LOGIC DIAGRAM (POSITIVE LOGIC)**

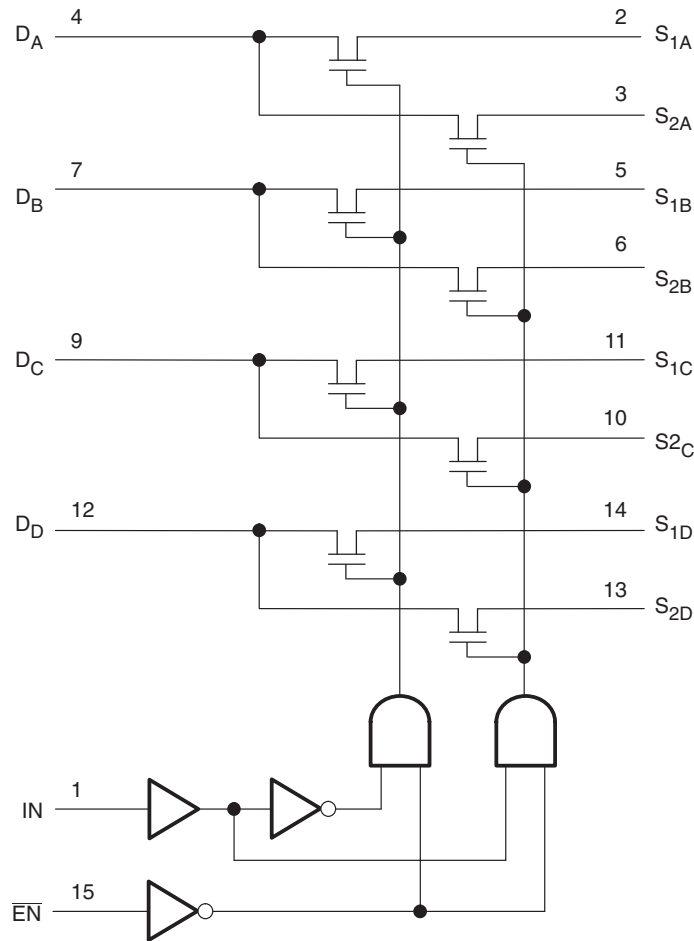

**ABSOLUTE MAXIMUM RATINGS<sup>(1)</sup>**

over operating free-air temperature range (unless otherwise noted)

		MIN	MAX	UNIT
V <sub>CC</sub>	Supply voltage range	-0.5	7	V
V <sub>IN</sub>	Control input voltage range <sup>(2) (3)</sup>	-0.5	7	V
V <sub>I/O</sub>	Output voltage range <sup>(2) (3) (4)</sup>	-0.5	7	V
I <sub>IK</sub>	Control input clamp current		-50	mA
I <sub>I/OK</sub>	I/O port clamp current		-50	mA
I <sub>I/O</sub>	ON-state switch current <sup>(5)</sup>		±128	mA
	Continuous current through V <sub>CC</sub> or GND		±100	mA
T <sub>stg</sub>	Storage temperature range	-65	150	°C

- (1) Stresses beyond those listed under "absolute maximum ratings" may cause permanent damage to the device. These are stress ratings only, and functional operation of the device at these or any other conditions beyond those indicated under "recommended operating conditions" is not implied. Exposure to absolute-maximum-rated conditions for extended periods may affect device reliability.
- (2) All voltages are with respect to ground unless otherwise specified.
- (3) The input and output voltage ratings may be exceeded if the input and output clamp-current ratings are observed.
- (4) V<sub>I</sub> and V<sub>O</sub> are used to denote specific conditions for V<sub>I/O</sub>.
- (5) I<sub>I</sub> and I<sub>O</sub> are used to denote specific conditions for I<sub>I/O</sub>.

## PACKAGE THERMAL IMPEDANCE

over operating free-air temperature range (unless otherwise noted)

			UNIT
$\theta_{JA}$	Package thermal impedance	D package <sup>(1)</sup>	73
		DB package <sup>(1)</sup>	82
		DBQ package <sup>(1)</sup>	90
		PW package <sup>(1)</sup>	108
		RGY package <sup>(2)</sup>	39
			°C/W

(1) The package thermal impedance is calculated in accordance with JESD 51-7.

(2) The package thermal impedance is calculated in accordance with JESD 51-5.

## RECOMMENDED OPERATING CONDITIONS<sup>(1)</sup>

		MIN	MAX	UNIT
$V_{CC}$	Supply voltage	4	5.5	V
$V_{IH}$	High-level control input voltage ( $\overline{EN}$ , IN)	2	5.5	V
$V_{IL}$	Low-level control input voltage ( $\overline{EN}$ , IN)	0	0.8	V
$V_{ANALOG}$	Analog input/output voltage	0	$V_{CC}$	V
$T_A$	Operating free-air temperature	-40	85	°C

(1) All unused control inputs of the device must be held at  $V_{CC}$  or GND to ensure proper device operation. Refer to the TI application report, *Implications of Slow or Floating CMOS Inputs*, literature number [SCBA004](#).

### ELECTRICAL CHARACTERISTICS<sup>(1)</sup>

over recommended operating free-air temperature range (unless otherwise noted)

PARAMETER		TEST CONDITIONS			MIN	TYP <sup>(2)</sup>	MAX	UNIT
V <sub>IK</sub>	$\overline{EN}$ , IN	V <sub>CC</sub> = 4.5 V,	I <sub>IN</sub> = -18 mA			-1.8	V	
V <sub>H</sub>	$\overline{EN}$ , IN					400	mV	
I <sub>IH</sub>	$\overline{EN}$ , IN	V <sub>CC</sub> = 5.5 V,	V <sub>IN</sub> and V <sub>EN</sub> = V <sub>CC</sub>			±1	µA	
I <sub>IL</sub>	$\overline{EN}$ , IN	V <sub>CC</sub> = 5.5 V,	V <sub>IN</sub> and V <sub>EN</sub> = GND			±1	µA	
I <sub>OZ</sub> <sup>(3)</sup>		V <sub>CC</sub> = 5.5 V,	V <sub>O</sub> = 0 to 5.5 V, V <sub>I</sub> = 0,	Switch OFF		±10	µA	
I <sub>OS</sub>		V <sub>CC</sub> = 5.5 V,	V <sub>O</sub> = 0 to 5.5 V, V <sub>I</sub> = 0,	Switch ON		±110	mA	
I <sub>off</sub>		V <sub>CC</sub> = 0,	V <sub>O</sub> = 0 to 5.5 V, V <sub>I</sub> = 0			±1	µA	
I <sub>CC</sub>		V <sub>CC</sub> = 5.5 V,	I <sub>I/O</sub> = 0,	Switch ON or OFF		3	µA	
ΔI <sub>CC</sub>	$\overline{EN}$ , IN	V <sub>CC</sub> = 5.5 V,	One input at 3.4 V,	Other inputs at V <sub>CC</sub> or GND		2.5	mA	
I <sub>CCD</sub>		V <sub>CC</sub> = 5.5 V, V <sub>EN</sub> = GND,	D and S ports are open,	V <sub>IN</sub> switching 50% duty cycle		0.25	mA/ MHz	
C <sub>in</sub>	$\overline{EN}$ , IN	V <sub>IN</sub> or V <sub>EN</sub> = 0	f = 1 MHz			3.5	pF	
C <sub>OFF</sub>	D port	V <sub>I/O</sub> = 3 V or 0,	Switch OFF,	V <sub>IN</sub> = V <sub>CC</sub> or GND		8.5	pF	
	S port		Switch ON,			5.5		
C <sub>ON</sub>		V <sub>I</sub> = 0,	f = 1 MHz, outputs open,	Switch ON		16.5	pF	
r <sub>ON</sub> <sup>(4)</sup>		V <sub>CC</sub> = 4.5 V	V <sub>I</sub> = 1 V,	I <sub>O</sub> = 13 mA, R <sub>L</sub> = 75 Ω		3	7	Ω
			V <sub>I</sub> = 2 V,	I <sub>O</sub> = 26 mA, R <sub>L</sub> = 75 Ω		3	10	

- (1) V<sub>I</sub>, V<sub>O</sub>, I<sub>I</sub>, and I<sub>O</sub> refer to the I/O pins.
- (2) All typical values are at V<sub>CC</sub> = 5 V (unless otherwise noted), T<sub>A</sub> = 25°C.
- (3) For I/O ports, the parameter I<sub>OZ</sub> includes the input leakage current.
- (4) Measured by the voltage drop between the D and S terminals at the indicated current through the switch. ON-state resistance is determined by the lower of the voltages of the two (S or D) terminals.

### SWITCHING CHARACTERISTICS

over recommended operating free-air temperature range, V<sub>CC</sub> = 5 V ±10%, R<sub>L</sub> = 75 Ω, C<sub>L</sub> = 20 pF (unless otherwise noted) (see [Figure 5](#))

PARAMETER	FROM (INPUT)	TO (OUTPUT)	MIN	TYP	MAX	UNIT
t <sub>ON</sub>	S	D	1.5		6.0	ns
t <sub>OFF</sub>	S	D	1.5		5.9	ns

### DYNAMIC CHARACTERISTICS

over recommended operating free-air temperature range, V<sub>CC</sub> = 5 V ±10% (unless otherwise noted)

PARAMETER	TEST CONDITIONS	MIN	TYP <sup>(1)</sup>	MAX	UNIT
D <sub>G</sub>	R <sub>L</sub> = 150 Ω, f = 3.58 MHz, see <a href="#">Figure 6</a>		0.24		%
D <sub>P</sub>	R <sub>L</sub> = 150 Ω, f = 3.58 MHz, see <a href="#">Figure 6</a>		0.039		°
BW	R <sub>L</sub> = 150 Ω, see <a href="#">Figure 7</a>		250		MHz
X <sub>TALK</sub>	R <sub>IN</sub> = 10 Ω, R <sub>L</sub> = 150 Ω, f = 10 MHz, see <a href="#">Figure 7</a>		-87		dB
O <sub>IRR</sub>	R <sub>L</sub> = 150 Ω, f = 10 MHz, see <a href="#">Figure 7</a>		-54		dB

- (1) All typical values are at V<sub>CC</sub> = 5 V (unless otherwise noted), T<sub>A</sub> = 25°C.

TYPICAL PERFORMANCE

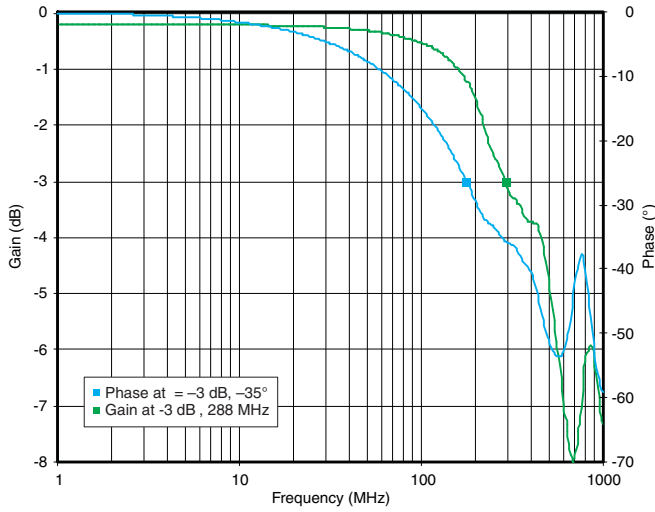

Figure 1. Frequency Response

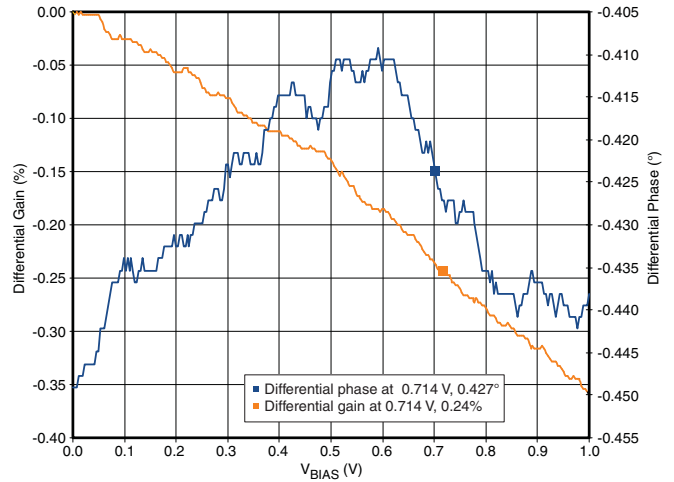

Figure 2. Differential Gain/Phase vs  $V_{BIAS}$

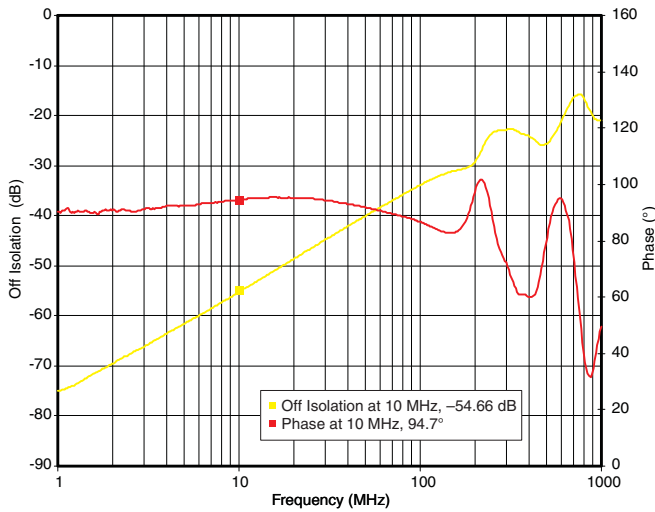

Figure 3. OFF-Isolation vs Frequency

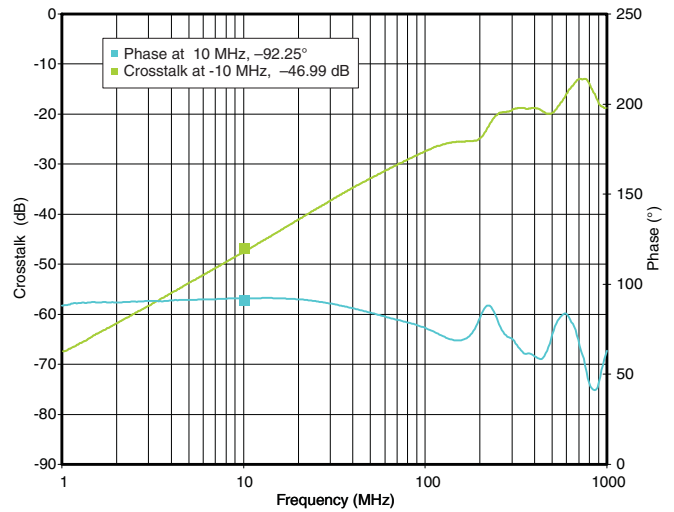
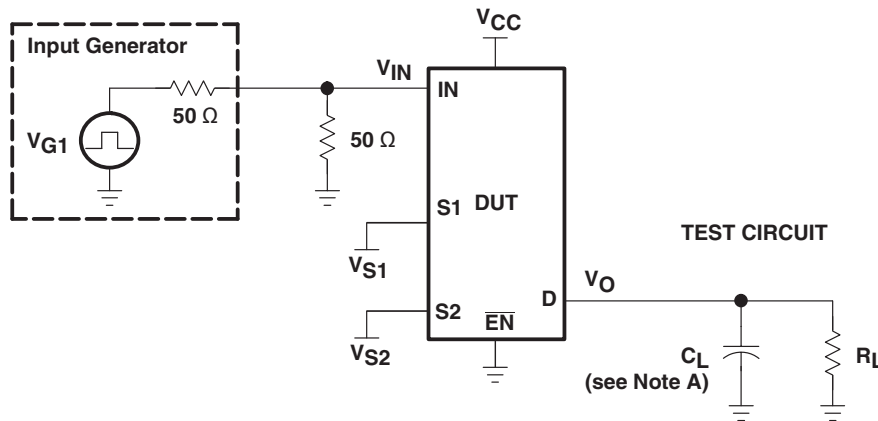
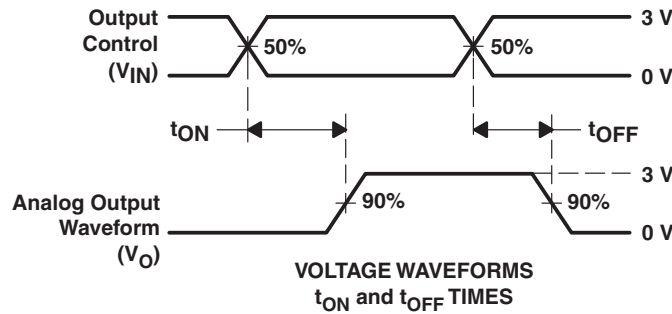

Figure 4. Crosstalk vs Frequency

PARAMETER MEASUREMENT INFORMATION



TEST	V <sub>CC</sub>	R <sub>L</sub>	C <sub>L</sub>	V <sub>S1</sub>	V <sub>S2</sub>
t <sub>ON</sub>	5 V ± 0.5 V	75 Ω	20 pF	GND	3 V
	5 V ± 0.5 V	75 Ω	20 pF	3 V	GND
t <sub>OFF</sub>	5 V ± 0.5 V	75 Ω	20 pF	GND	3 V
	5 V ± 0.5 V	75 Ω	20 pF	3 V	GND



- A. C<sub>L</sub> includes probe and jig capacitance.
- B. All input pulses are supplied by generators having the following characteristics: PRR ≤ 10 MHz, Z<sub>O</sub> = 50 Ω, t<sub>r</sub> ≤ 2.5 ns, t<sub>f</sub> ≤ 2.5 ns.
- C. The outputs are measured one at a time with one transition per measurement.

Figure 5. Test Circuit and Voltage Waveforms

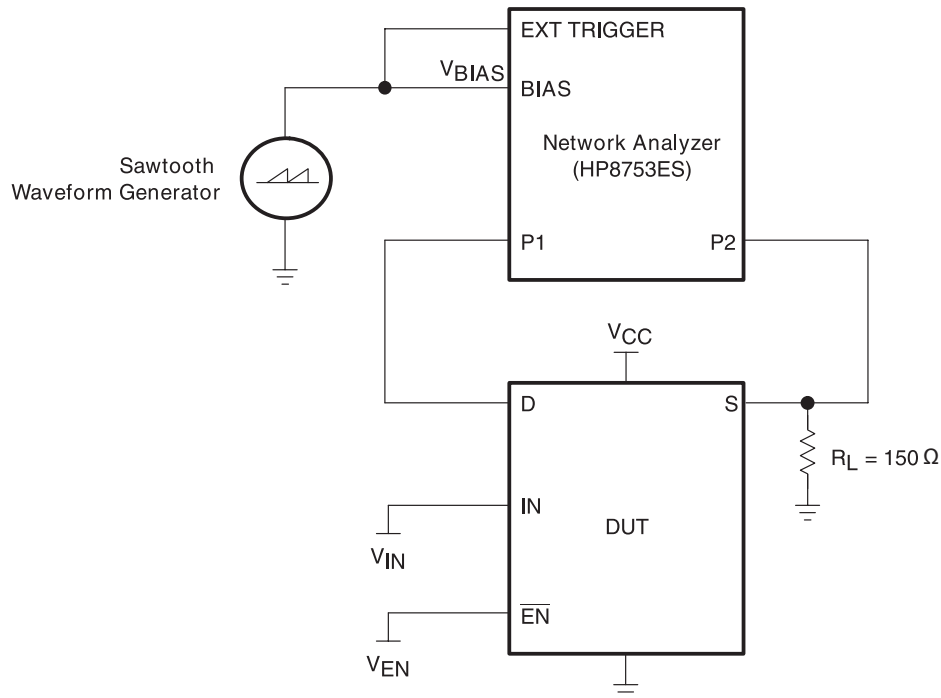
**PARAMETER MEASUREMENT INFORMATION (continued)**

For additional information, refer to the TI application report, *Measuring Differential Gain and Phase*, literature number [SLOA040](#).

**Figure 6. Test Circuit for Differential Gain/Phase Measurement**

The differential gain and phase is measured at the output of the ON channel. For example, when  $V_{IN} = 0$ ,  $V_{EN} = 0$ , and  $D_A$  is the input, the output is measured at  $S_{1A}$ .

**HP8753ES Setup**

Average = 20

RBW = 300 Hz

Smoothing = 2%

$V_{BIAS} = 0$  to 1 V

ST = 1.381 s.

P1 = -7 dBm

CW frequency = 3.58 MHz

## PARAMETER MEASUREMENT INFORMATION (continued)

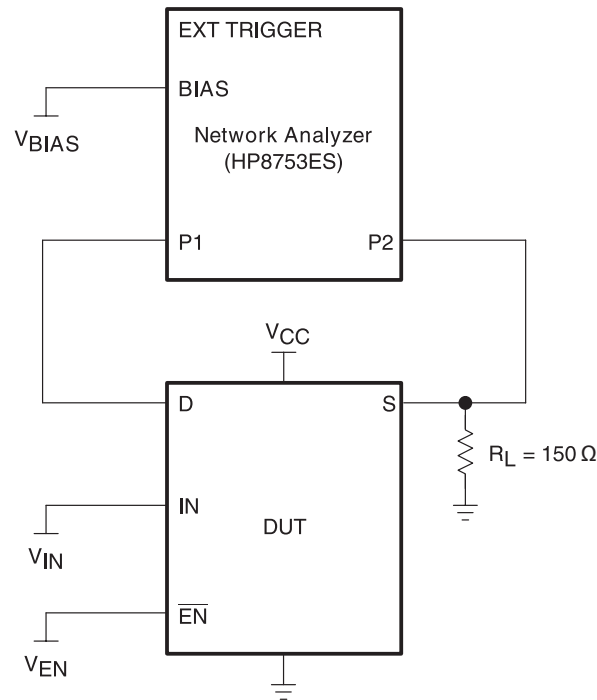

**Figure 7. Test Circuit for Frequency Response, Crosstalk, and OFF-Isolation**

The frequency response is measured at the output of the ON channel. For example, when  $V_{IN} = 0$ ,  $V_{EN} = 0$ , and  $D_A$  is the input, the output is measured at  $S_{1A}$ . All unused analog I/O ports are held at  $V_{CC}$  or GND.

The crosstalk is measured at the output of the non-adjacent ON channel. For example, when  $V_{IN} = 0$ ,  $V_{EN} = 0$ , and  $D_A$  is the input, the output is measured at  $S_{1B}$ . All unused analog I/O ports are held at  $V_{CC}$  or GND.

The off-isolation is measured at the output of the OFF channel. For example, when  $V_{IN} = 0$ ,  $V_{EN} = V_{CC}$ , and  $D_A$  is the input, the output is measured at  $S_{1A}$ . All unused analog I/O ports are held at  $V_{CC}$  or GND.

### HP8753ES Setup

Average = 4

RBW = 3 kHz

Smoothing = 0%

$V_{BIAS} = 0.35$  V

ST = 2 s

P1 = 0 dBm

**PACKAGING INFORMATION**

Orderable Device	Status (1)	Package Type	Package Drawing	Pins	Package Qty	Eco Plan (2)	Lead/Ball Finish (6)	MSL Peak Temp (3)	Op Temp (°C)	Device Marking (4/5)	Samples
TS5V330CDBQR	ACTIVE	SSOP	DBQ	16	2500	Green (RoHS & no Sb/Br)	CU NIPDAU	Level-2-260C-1 YEAR	-40 to 85	TE330C	<a href="#">Samples</a>
TS5V330CDR	ACTIVE	SOIC	D	16	2500	Green (RoHS & no Sb/Br)	CU NIPDAU	Level-1-260C-UNLIM	-40 to 85	TS5V330C	<a href="#">Samples</a>
TS5V330CPWR	ACTIVE	TSSOP	PW	16	2000	Green (RoHS & no Sb/Br)	CU NIPDAU	Level-1-260C-UNLIM	-40 to 85	TE330C	<a href="#">Samples</a>

(1) The marketing status values are defined as follows:

**ACTIVE:** Product device recommended for new designs.

**LIFEBUY:** TI has announced that the device will be discontinued, and a lifetime-buy period is in effect.

**NRND:** Not recommended for new designs. Device is in production to support existing customers, but TI does not recommend using this part in a new design.

**PREVIEW:** Device has been announced but is not in production. Samples may or may not be available.

**OBsolete:** TI has discontinued the production of the device.

(2) **RoHS:** TI defines "RoHS" to mean semiconductor products that are compliant with the current EU RoHS requirements for all 10 RoHS substances, including the requirement that RoHS substance do not exceed 0.1% by weight in homogeneous materials. Where designed to be soldered at high temperatures, "RoHS" products are suitable for use in specified lead-free processes. TI may reference these types of products as "Pb-Free".

**RoHS Exempt:** TI defines "RoHS Exempt" to mean products that contain lead but are compliant with EU RoHS pursuant to a specific EU RoHS exemption.

**Green:** TI defines "Green" to mean the content of Chlorine (Cl) and Bromine (Br) based flame retardants meet JS709B low halogen requirements of <=1000ppm threshold. Antimony trioxide based flame retardants must also meet the <=1000ppm threshold requirement.

(3) MSL, Peak Temp. - The Moisture Sensitivity Level rating according to the JEDEC industry standard classifications, and peak solder temperature.

(4) There may be additional marking, which relates to the logo, the lot trace code information, or the environmental category on the device.

(5) Multiple Device Markings will be inside parentheses. Only one Device Marking contained in parentheses and separated by a "-" will appear on a device. If a line is indented then it is a continuation of the previous line and the two combined represent the entire Device Marking for that device.

(6) Lead/Ball Finish - Orderable Devices may have multiple material finish options. Finish options are separated by a vertical ruled line. Lead/Ball Finish values may wrap to two lines if the finish value exceeds the maximum column width.

**Important Information and Disclaimer:** The information provided on this page represents TI's knowledge and belief as of the date that it is provided. TI bases its knowledge and belief on information provided by third parties, and makes no representation or warranty as to the accuracy of such information. Efforts are underway to better integrate information from third parties. TI has taken and continues to take reasonable steps to provide representative and accurate information but may not have conducted destructive testing or chemical analysis on incoming materials and chemicals. TI and TI suppliers consider certain information to be proprietary, and thus CAS numbers and other limited information may not be available for release.

In no event shall TI's liability arising out of such information exceed the total purchase price of the TI part(s) at issue in this document sold by TI to Customer on an annual basis.

**TAPE AND REEL INFORMATION**

**QUADRANT ASSIGNMENTS FOR PIN 1 ORIENTATION IN TAPE**

\*All dimensions are nominal

Device	Package Type	Package Drawing	Pins	SPQ	Reel Diameter (mm)	Reel Width W1 (mm)	A0 (mm)	B0 (mm)	K0 (mm)	P1 (mm)	W (mm)	Pin1 Quadrant
TS5V330CDBQR	SSOP	DBQ	16	2500	330.0	12.5	6.4	5.2	2.1	8.0	12.0	Q1
TS5V330CDR	SOIC	D	16	2500	330.0	16.4	6.5	10.3	2.1	8.0	16.0	Q1
TS5V330CPWR	TSSOP	PW	16	2000	330.0	12.4	6.9	5.6	1.6	8.0	12.0	Q1

**TAPE AND REEL BOX DIMENSIONS**

\*All dimensions are nominal

Device	Package Type	Package Drawing	Pins	SPQ	Length (mm)	Width (mm)	Height (mm)
TS5V330CDBQR	SSOP	DBQ	16	2500	340.5	338.1	20.6
TS5V330CDR	SOIC	D	16	2500	333.2	345.9	28.6
TS5V330CPWR	TSSOP	PW	16	2000	367.0	367.0	35.0

D (R-PDSO-G16)

PLASTIC SMALL OUTLINE



- NOTES:
- A. All linear dimensions are in inches (millimeters).
  - B. This drawing is subject to change without notice.
  - C. Body length does not include mold flash, protrusions, or gate burrs. Mold flash, protrusions, or gate burrs shall not exceed 0.006 (0,15) each side.
  - D. Body width does not include interlead flash. Interlead flash shall not exceed 0.017 (0,43) each side.
  - E. Reference JEDEC MS-012 variation AC.

D (R-PDSO-G16)

PLASTIC SMALL OUTLINE



- NOTES:
- A. All linear dimensions are in millimeters.
  - B. This drawing is subject to change without notice.
  - C. Publication IPC-7351 is recommended for alternate designs.
  - D. Laser cutting apertures with trapezoidal walls and also rounding corners will offer better paste release. Customers should contact their board assembly site for stencil design recommendations. Refer to IPC-7525 for other stencil recommendations.
  - E. Customers should contact their board fabrication site for solder mask tolerances between and around signal pads.



4220204/A 02/2017

# EXAMPLE BOARD LAYOUT

PW0016A

TSSOP - 1.2 mm max height

SMALL OUTLINE PACKAGE



LAND PATTERN EXAMPLE  
EXPOSED METAL SHOWN  
SCALE: 10X



SOLDER MASK DETAILS

4220204/A 02/2017

NOTES: (continued)

- 6. Publication IPC-7351 may have alternate designs.
- 7. Solder mask tolerances between and around signal pads can vary based on board fabrication site.

# EXAMPLE STENCIL DESIGN

PW0016A

TSSOP - 1.2 mm max height

SMALL OUTLINE PACKAGE



SOLDER PASTE EXAMPLE  
BASED ON 0.125 mm THICK STENCIL  
SCALE: 10X

4220204/A 02/2017

NOTES: (continued)

8. Laser cutting apertures with trapezoidal walls and rounded corners may offer better paste release. IPC-7525 may have alternate design recommendations.
9. Board assembly site may have different recommendations for stencil design.

**GENERIC PACKAGE VIEW**

**DBQ 16**

**SSOP - 1.75 mm max height**

SHRINK SMALL-OUTLINE PACKAGE

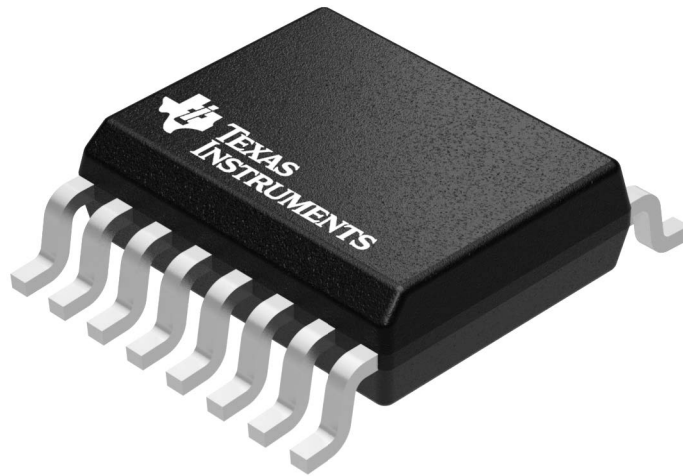

Images above are just a representation of the package family, actual package may vary.  
Refer to the product data sheet for package details.

4073301-2/1



# EXAMPLE BOARD LAYOUT

DBQ0016A

SSOP - 1.75 mm max height

SHRINK SMALL-OUTLINE PACKAGE

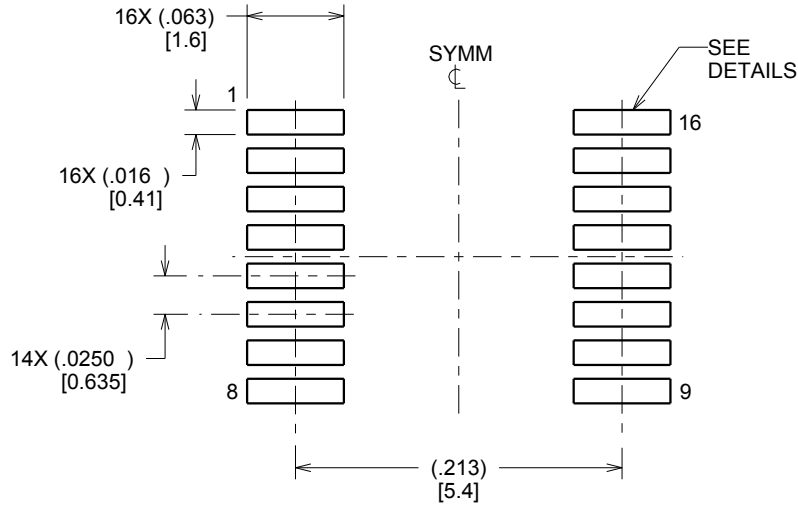

LAND PATTERN EXAMPLE  
SCALE:8X

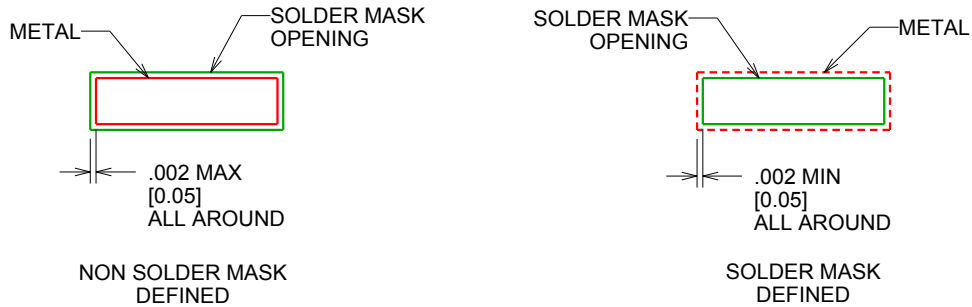

SOLDER MASK DETAILS

4214846/A 03/2014

NOTES: (continued)

- 6. Publication IPC-7351 may have alternate designs.
- 7. Solder mask tolerances between and around signal pads can vary based on board fabrication site.

# EXAMPLE STENCIL DESIGN

DBQ0016A

SSOP - 1.75 mm max height

SHRINK SMALL-OUTLINE PACKAGE

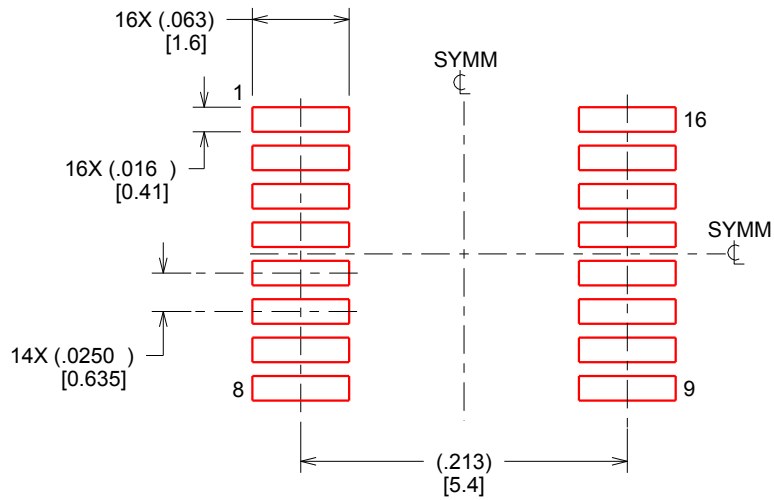

SOLDER PASTE EXAMPLE  
BASED ON .005 INCH [0.127 MM] THICK STENCIL  
SCALE:8X

4214846/A 03/2014

NOTES: (continued)

8. Laser cutting apertures with trapezoidal walls and rounded corners may offer better paste release. IPC-7525 may have alternate design recommendations.
9. Board assembly site may have different recommendations for stencil design.

## IMPORTANT NOTICE AND DISCLAIMER

TI PROVIDES TECHNICAL AND RELIABILITY DATA (INCLUDING DATASHEETS), DESIGN RESOURCES (INCLUDING REFERENCE DESIGNS), APPLICATION OR OTHER DESIGN ADVICE, WEB TOOLS, SAFETY INFORMATION, AND OTHER RESOURCES "AS IS" AND WITH ALL FAULTS, AND DISCLAIMS ALL WARRANTIES, EXPRESS AND IMPLIED, INCLUDING WITHOUT LIMITATION ANY IMPLIED WARRANTIES OF MERCHANTABILITY, FITNESS FOR A PARTICULAR PURPOSE OR NON-INFRINGEMENT OF THIRD PARTY INTELLECTUAL PROPERTY RIGHTS.

These resources are intended for skilled developers designing with TI products. You are solely responsible for (1) selecting the appropriate TI products for your application, (2) designing, validating and testing your application, and (3) ensuring your application meets applicable standards, and any other safety, security, or other requirements. These resources are subject to change without notice. TI grants you permission to use these resources only for development of an application that uses the TI products described in the resource. Other reproduction and display of these resources is prohibited. No license is granted to any other TI intellectual property right or to any third party intellectual property right. TI disclaims responsibility for, and you will fully indemnify TI and its representatives against, any claims, damages, costs, losses, and liabilities arising out of your use of these resources.

TI's products are provided subject to TI's Terms of Sale ([www.ti.com/legal/termsofsale.html](http://www.ti.com/legal/termsofsale.html)) or other applicable terms available either on [ti.com](http://ti.com) or provided in conjunction with such TI products. TI's provision of these resources does not expand or otherwise alter TI's applicable warranties or warranty disclaimers for TI products.

Mailing Address: Texas Instruments, Post Office Box 655303, Dallas, Texas 75265  
Copyright © 2018, Texas Instruments Incorporated

## Looking for pricing, stock, or lifecycle information?

Click below to explore more details on WIN SOURCE:

 [View TS5V330CPWR on WIN SOURCE](#)

 [Texas Instruments](#) Information

## Optimize Your Supply Chain with WIN SOURCE Solutions

-  Global Sourcing Solution
-  Obsolete Management
-  Cost Control Management
-  Shortage Management
-  Alternative Solution
-  Excess Inventory Management