



THE DATASHEET OF
1013



THM LOW PROFILE LITHIUM & ALKALINE CELL HOLDERS

"1/3N" · "AAA" · "1/2AA" · "CR2" · "AA" · "2/3A"

FEATURES

- Snap-In PC contact holds firmly in position for wave soldering
- Tin Nickel Plated contacts for excellent solderability and durability
- Polarity clearly marked for orientation
- Snap-on retainer cover (optional) retains battery securely to withstand shock and vibration. Helps protect against shorting. Tamper-proof.

APPLICATIONS

- Computer memory, power backup systems.
- Telecommunications
- Residential, industrial and commercial security systems
- PLC and industrial controls

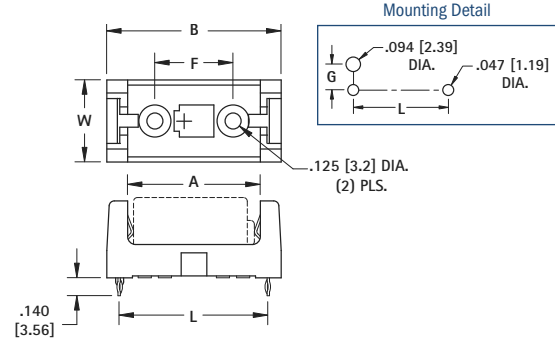

SPECIFICATIONS

Base/Retainer Cover: PBT, UL 94V-0
Contacts: .012 (.30) Stainless Steel, Tin-Nickel Plate
Operating Temp Range: -60°F to +290°F (-50°C to +145°C)

HOLDER COVER									CELL SIZE	PACKAGING SPECS	BATTERY CROSS REFERENCE
CAT. NO.	CAT. NO.	L	W	H (Ref. Dim)	A	B	F	G			
108	108C	1.160 (29.5)	.640 (16.3)	.633 (16.1)	1.030 (26.2)	1.360 (34.5)	.610 (15.5)	.279 (7.1)	"1/2 AA" "CR2"	50 pieces per tray Energizer 544, CR2, Duracell PX28L, CR2, Kodak K28A & KS28, CR2, Panasonic CR14250, CR2, Saft LCP3, Maxell 4LR44, CR2, Sanyo CR14250SE, CR2	
1028	1024C 1028C	2.160 (54.9)	.640 (16.3)	.633 (16.1)	2.040 (51.8)	2.360 (59.9)	1.610 (40.9)	.279 (7.1)	"AA"	50 pieces per tray Energizer, Duracell, Panasonic, Sanyo, Varta, Rayovac, Tadiran	
1029	1029C 1029LC	1.500 (38.1)	.720 (18.3)	.712 (18.1)	1.375 (34.9)	1.700 (43.2)	.950 (24.1)	.320 (8.1)	"2/3 A"	50 pieces per tray Duracell DL2/3A, Kodak K123L, Panasonic CR123A, Saft 450SC & VR0450, Sanyo CR17335SE	

THM ULTRA LOW PROFILE

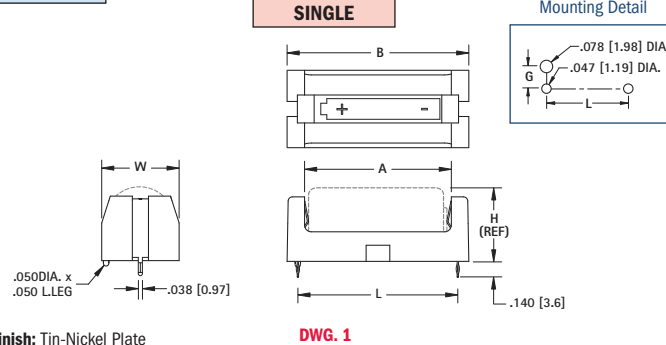
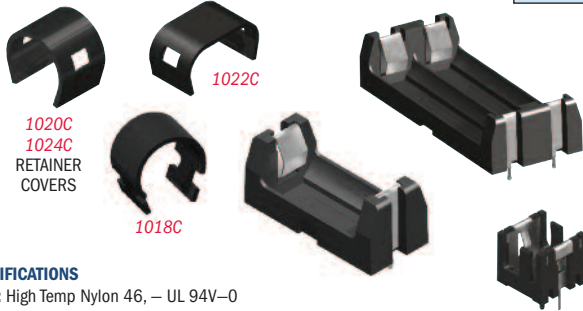

SPECIFICATIONS

Base: High Temp Nylon 46, - UL 94V-0
Contacts: .012 (.30) Stainless Steel, Tin-Nickel Plate
Operating Temp Range: -60°F to +290°F (-50°C to +145°C)

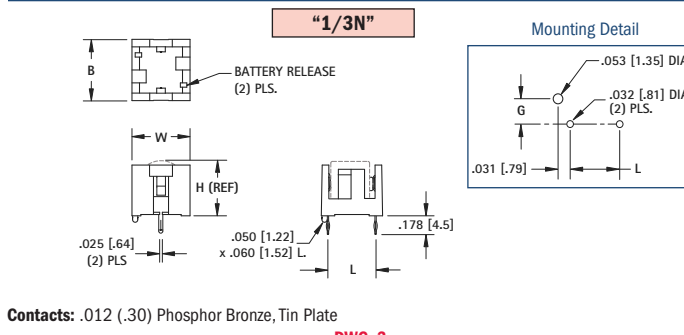
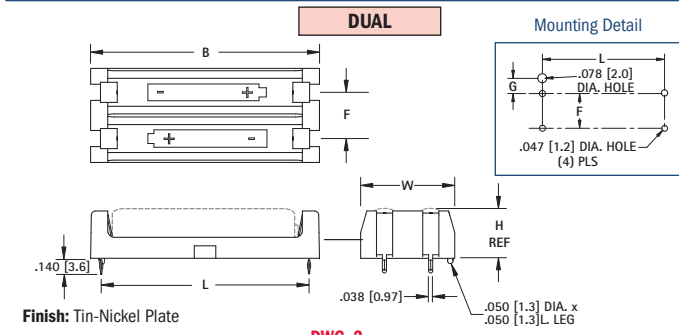



HOLDER COVER									CELL SIZE	PACKAGING SPECS	BATTERY CROSS REFERENCE
CAT. NO.	CAT. NO.	DWG NO.	L	W	H (Ref. Dim)	B	F	G			
1021	1020C	1	1.933 (49.1)	.500 (12.7)	.445 (11.3)	2.140 (54.4)	-	.209 (5.3)	"AAA"	50 pieces per tray All Major Manufacturers	
1023	1022C	2	1.933 (49.1)	.875 (22.2)	.445 (11.3)	2.140 (54.4)	.430 (10.9)	.182 (4.6)	"AAA"	25 pieces per tray All Major Manufacturers	
1015	1024C	1	2.145 (54.5)	.612 (15.5)	.603 (15.3)	2.359 (59.9)	-	.265 (6.7)	"AA"	50 pieces per tray All Major Manufacturers	
1013	1012C	2	2.145 (54.5)	1.180 (30.0)	.603 (15.3)	2.359 (59.9)	.568 (14.4)	.265 (6.7)	"AA"	25 pieces per tray All Major Manufacturers	
1017	1024C	1	1.156 (29.4)	.612 (15.5)	.603 (15.3)	1.360 (34.5)	-	.265 (6.7)	"1/2 AA"	50 pieces per tray Energizer 544, Duracell PX28L, Kodak K28A & KS28, Saft LCP3, Maxell 4LR44, Sanyo CR14250SE	
1019	1018C	1	1.487 (37.8)	.720 (18.3)	.682 (17.3)	1.690 (42.9)	-	.319 (8.1)	"2/3 A"	50 pieces per tray Duracell DL2/3A, Kodak K123L, Saft 450SC & VR0450, Sanyo CR17335SE	
1099	-	2	1.487 (37.8)	1.440 (36.6)	.682 (17.3)	1.690 (42.9)	.720 (18.3)	.319 (8.1)	"2/3 A"	25 pieces per tray Duracell DL1/3N, Sanyo K58L, Energizer CR1/3N	
503*	-	3	.450 (11.4)	.540 (13.7)	.506 (12.9)	.570 (14.5)	-	.240 (6.1)	"1/3 N"	300 pieces per tray Duracell DL1/3N, Sanyo K58L, Energizer CR1/3N	

*Cat. No. 503 Gold Plate Flash

THM BATTERY HOLDERS

Looking for pricing, stock, or lifecycle information?

Click below to explore more details on WIN SOURCE:

-  [View 1013 on WIN SOURCE](#)
-  [Keystone Electronics Information](#)

Optimize Your Supply Chain with WIN SOURCE Solutions

-  Global Sourcing Solution
-  Obsolete Management
-  Cost Control Management
-  Shortage Management
-  Alternative Solution
-  Excess Inventory Management