



# THE DATASHEET OF CDCVF855PWR



## 2.5-V PHASE-LOCKED-LOOP CLOCK DRIVER

### FEATURES

- Spread-Spectrum Clock Compatible
- Operating Frequency: 60 MHz to 220 MHz
- Low Jitter (Cycle-Cycle):  $\pm 60$  ps ( $\pm 40$  ps at 200 MHz)
- Low Static Phase Offset:  $\pm 50$  ps
- Low Jitter (Period):  $\pm 60$  ps ( $\pm 30$  ps at 200 MHz)
- 1-to-4 Differential Clock Distribution (SSTL2)
- Best in Class for  $V_{OX} = V_{DD}/2 \pm 0.1$  V
- Operates From Dual 2.6-V or 2.5-V Supplies
- Available in a 28-Pin TSSOP Package
- Consumes  $< 100$ - $\mu$ A Quiescent Current
- External Feedback Pins (FBIN,  $\overline{\text{FBIN}}$ ) Are Used to Synchronize the Outputs to the Input Clocks
- Meets/Exceeds JEDEC Standard (JESD82-1) For DDRI-200/266/333 Specification
- Meets/Exceeds Proposed DDRI-400 Specification (JESD82-1A)
- Enters Low-Power Mode When No CLK Input Signal Is Applied or  $\overline{\text{PWRDWN}}$  Is Low

### APPLICATIONS

- DDR Memory Modules (DDR400/333/266/200)
- Zero-Delay Fan-Out Buffer

### DESCRIPTION

The CDCVF855 is a high-performance, low-skew, low-jitter, zero-delay buffer that distributes a differential clock input pair (CLK,  $\overline{\text{CLK}}$ ) to 4 differential pairs of clock outputs (Y[0:3],  $\overline{\text{Y}}[0:3]$ ) and one differential pair of feedback clock outputs (FBOUT,  $\overline{\text{FBOUT}}$ ). The clock outputs are controlled by the clock inputs (CLK,  $\overline{\text{CLK}}$ ), the feedback clocks (FBIN,  $\overline{\text{FBIN}}$ ), and the analog power input ( $\text{AV}_{DD}$ ). When  $\overline{\text{PWRDWN}}$  is high, the outputs switch in phase and frequency with CLK. When  $\overline{\text{PWRDWN}}$  is low, all outputs are disabled to a high-impedance state (3-state) and the PLL is shut down (low-power mode). The device also enters this low-power mode when the input frequency falls below a suggested detection frequency that is below 20 MHz (typical 10 MHz). An input frequency-detection circuit detects the low-frequency condition and, after applying a  $>20$ -MHz input signal, this detection circuit turns the PLL on and enables the outputs.

When  $\text{AV}_{DD}$  is strapped low, the PLL is turned off and bypassed for test purposes. The CDCVF855 is also able to track spread-spectrum clocking for reduced EMI.

Because the CDCVF855 is based on PLL circuitry, it requires a stabilization time to achieve phase-lock of the PLL. This stabilization time is required following power up. The CDCVF855 is characterized for both commercial and industrial temperature ranges.

### AVAILABLE OPTIONS

$T_A$	TSSOP (PW)
$-40^\circ\text{C}$ to $85^\circ\text{C}$	CDCVF855PW



Please be aware that an important notice concerning availability, standard warranty, and use in critical applications of Texas Instruments semiconductor products and disclaimers thereto appears at the end of this data sheet.

**FUNCTION TABLE  
(Select Functions)**

INPUTS				OUTPUTS				PLL
AVDD	PWRDWN	CLK	CLK	Y[0:3]	Y[0:3]	FBOUT	FBOUT	
GND	H	L	H	L	H	L	H	Bypassed/off
GND	H	H	L	H	L	H	L	Bypassed/off
X	L	L	H	Z	Z	Z	Z	Off
X	L	H	L	Z	Z	Z	Z	Off
2.5 V (nom)	H	L	H	L	H	L	H	On
2.5 V (nom)	H	H	L	H	L	H	L	On
2.5 V (nom)	X	<20 MHz	<20 MHz	Z	Z	Z	Z	Off

**PW PACKAGE  
(TOP VIEW)**

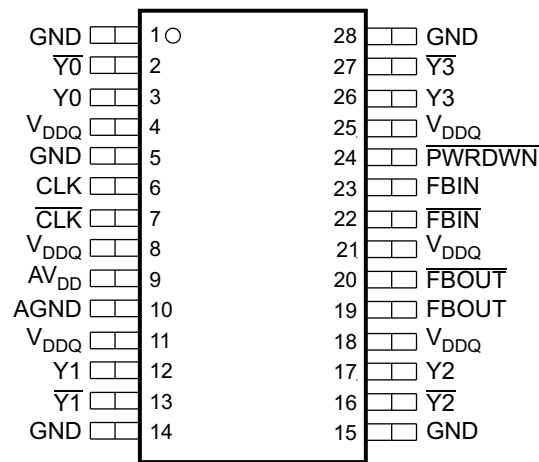

P0043-02

**FUNCTIONAL BLOCK DIAGRAM**

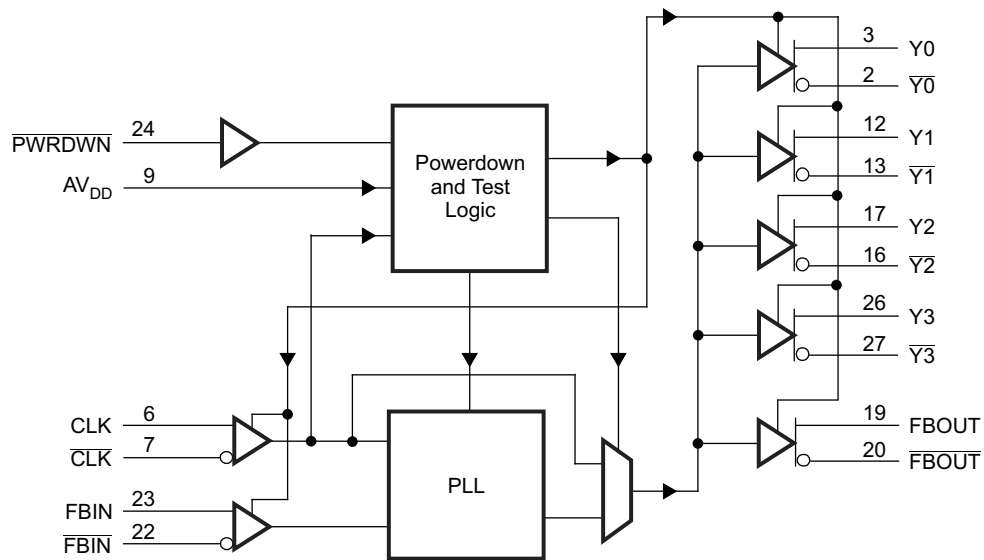

B0196-02

**Table 2. TERMINAL FUNCTIONS**

TERMINAL		I/O	DESCRIPTION
NAME	NO.		
AGND	10	–	Ground for 2.5-V analog supply
AV <sub>DD</sub>	9	–	2.5-V analog supply
CLK, $\overline{\text{CLK}}$	6, 7	I	Differential clock input
FBIN, FBIN	22, 23	I	Feedback differential clock input
FBOU, $\overline{\text{FBOU}}$	19, 20	O	Feedback differential clock output
GND	1, 5, 14, 15, 28	–	Ground
PWRDWN	24	I	Output enable for Y and $\overline{\text{Y}}$
V <sub>DDQ</sub>	4, 8, 11, 18, 21, 25	–	2.5-V supply
$\overline{\text{Y0}}$ , Y0	2, 3	O	Buffered output copies of input clock, CLK, $\overline{\text{CLK}}$
Y1, $\overline{\text{Y1}}$	12, 13	O	Buffered output copies of input clock, CLK, $\overline{\text{CLK}}$
$\overline{\text{Y2}}$ , Y2	16, 17	O	Buffered output copies of input clock, CLK, $\overline{\text{CLK}}$
Y3, $\overline{\text{Y3}}$	26, 27	O	Buffered output copies of input clock, CLK, $\overline{\text{CLK}}$

### ABSOLUTE MAXIMUM RATINGS

over operating free-air temperature range (unless otherwise noted) <sup>(1)</sup>

V <sub>DDQ</sub> , AV <sub>DD</sub>	Supply voltage range		0.5 V to 3.6 V
V <sub>I</sub>	Input voltage range <sup>(2)(3)</sup>		–0.5 V to V <sub>DDQ</sub> + 0.5 V
V <sub>O</sub>	Output voltage range <sup>(2)(3)</sup>		–0.5 V to V <sub>DDQ</sub> + 0.5 V
I <sub>IK</sub>	Input clamp current	V <sub>I</sub> < 0 or V <sub>I</sub> > V <sub>DDQ</sub>	±50 mA
I <sub>OK</sub>	Output clamp current	V <sub>O</sub> < 0 or V <sub>O</sub> > V <sub>DDQ</sub>	±50 mA
I <sub>O</sub>	Continuous output current	V <sub>O</sub> = 0 to V <sub>DDQ</sub>	±50 mA
I <sub>DDS</sub>	Continuous current to GND or V <sub>DDQ</sub>		±100 mA
T <sub>stg</sub>	Storage temperature range		–65°C to 150°C

(1) Stresses beyond those listed under "absolute maximum ratings" may cause permanent damage to the device. These are stress ratings only, and functional operation of the device at these or any other conditions beyond those indicated under "recommended operating conditions" is not implied. Exposure to absolute-maximum-rated conditions for extended periods may affect device reliability.

(2) The input and output negative voltage ratings may be exceeded if the input and output clamp current ratings are observed.

(3) This value is limited to 3.6 V maximum.

### THERMAL CHARACTERISTICS

R <sub>θJA</sub> for TSSOP Package <sup>(1)</sup>	
Airflow	High K
0 ft/min (0 m/min)	94.4°C/W
150 ft/min (45.72 m/min)	82.8°C/W

(1) The package thermal impedance is calculated in accordance with JESD 51.

## RECOMMENDED OPERATING CONDITIONS

			MIN	NOM	MAX	UNIT
Supply voltage	V <sub>DDQ</sub>	PC1600 – PC3200	2.3		2.7	V
	AV <sub>DD</sub>		V <sub>DDQ</sub> – 0.12		2.7	
V <sub>IL</sub> Low-level input voltage	CLK, $\overline{\text{CLK}}$ , FBIN, $\overline{\text{FBIN}}$				V <sub>DDQ</sub> /2 – 0.18	V
	PWRDWN		–0.3		0.7	
V <sub>IH</sub> High-level input voltage	CLK, $\overline{\text{CLK}}$ , FBIN, $\overline{\text{FBIN}}$		V <sub>DDQ</sub> /2 + 0.18			V
	PWRDWN		1.7		V <sub>DDQ</sub> + 0.3	
DC input signal voltage <sup>(1)</sup>			–0.3		V <sub>DDQ</sub> + 0.3	V
V <sub>ID</sub> Differential input signal voltage <sup>(2)</sup>	DC	CLK, FBIN	V <sub>DDQ</sub> = 2.3 V – 2.7 V	0.36	V <sub>DDQ</sub> + 0.6	V
			V <sub>DDQ</sub> = 2.425 V – 2.7 V	0.25	V <sub>DDQ</sub> + 0.6	
	AC	CLK, FBIN	V <sub>DDQ</sub> = 2.3 V – 2.7 V	0.7	V <sub>DDQ</sub> + 0.6	
			V <sub>DDQ</sub> = 2.425 V – 2.7 V	0.49	V <sub>DDQ</sub> + 0.6	
V <sub>IX</sub> Input differential pair cross voltage <sup>(3)(4)</sup>			V <sub>DDQ</sub> /2 – 0.2		V <sub>DDQ</sub> /2 + 0.2	V
I <sub>OH</sub> High-level output current					–12	mA
I <sub>OL</sub> Low-level output current					12	mA
SR Input slew rate			1		4	V/ns
T <sub>A</sub> Operating free-air temperature			–40		85	°C

- (1) The unused inputs must be held high or low to prevent them from floating.
- (2) The dc input signal voltage specifies the allowable dc execution of the differential input.
- (3) The differential input signal voltage specifies the differential voltage |V<sub>TR</sub> – V<sub>CP</sub>| required for switching, where V<sub>TR</sub> is the true input level and V<sub>CP</sub> is the complementary input level.
- (4) The differential cross-point voltage is expected to track variations of V<sub>CC</sub> and is the voltage at which the differential signals must cross.

## ELECTRICAL CHARACTERISTICS

over recommended operating free-air temperature range (unless otherwise noted)

PARAMETER	TEST CONDITIONS	MIN	TYP <sup>(1)</sup>	MAX	UNIT
V <sub>IK</sub> Input voltage, all inputs	V <sub>DDQ</sub> = 2.3 V, I <sub>I</sub> = –18 mA			–1.2	V
V <sub>OH</sub> High-level output voltage	V <sub>DDQ</sub> = min to max, I <sub>OH</sub> = –1 mA	V <sub>DDQ</sub> – 0.1			V
	V <sub>DDQ</sub> = 2.3 V, I <sub>OH</sub> = –12 mA	1.7			
V <sub>OL</sub> Low-level output voltage	V <sub>DDQ</sub> = min to max, I <sub>OL</sub> = 1 mA			0.1	V
	V <sub>DDQ</sub> = 2.3 V, I <sub>OL</sub> = 12 mA			0.6	
V <sub>OD</sub> Output voltage swing <sup>(2)</sup>		1.1		V <sub>DDQ</sub> – 0.4	V
V <sub>OX</sub> Output differential cross-voltage <sup>(3)</sup>	Differential outputs are terminated with 120 Ω, C <sub>L</sub> = 14 pF (See Figure 3)	V <sub>DDQ</sub> /2 – 0.1	V <sub>DDQ</sub> /2	V <sub>DDQ</sub> /2 + 0.1	V
I <sub>I</sub> Input current	V <sub>DDQ</sub> = 2.7 V, V <sub>I</sub> = 0 V to 2.7 V			±10	μA
I <sub>OZ</sub> High-impedance-state output current	V <sub>DDQ</sub> = 2.7 V, V <sub>O</sub> = V <sub>DDQ</sub> or GND			±10	μA
I <sub>DDPD</sub> Power-down current on V <sub>DDQ</sub> + AV <sub>DD</sub>	CLK and $\overline{\text{CLK}}$ = 0 MHz; PWRDWN = Low; Σ of I <sub>DD</sub> and AI <sub>DD</sub>		20	100	μA
AI <sub>DD</sub> Supply current on AV <sub>DD</sub>	f <sub>O</sub> = 170 MHz		6	8	mA
	f <sub>O</sub> = 200 MHz		8	10	
C <sub>I</sub> Input capacitance	V <sub>DDQ</sub> = 2.5 V, V <sub>I</sub> = V <sub>DDQ</sub> or GND	2	2.5	3.5	pF

- (1) All typical values are at a nominal V<sub>DDQ</sub>.
- (2) The differential output signal voltage specifies the differential voltage |V<sub>TR</sub> – V<sub>CP</sub>|, where V<sub>TR</sub> is the true output level and V<sub>CP</sub> is the complementary output level.
- (3) The differential cross-point voltage tracks variations of V<sub>DDQ</sub> and is the voltage at which the differential signals must cross.

**ELECTRICAL CHARACTERISTICS (continued)**

over recommended operating free-air temperature range (unless otherwise noted)

PARAMETER		TEST CONDITIONS		MIN	TYP <sup>(1)</sup>	MAX	UNIT
I <sub>DD</sub>	Dynamic current on V <sub>DDQ</sub>	Without load	f <sub>O</sub> = 170 MHz		65	80	mA
			f <sub>O</sub> = 200 MHz		75	90	
		Differential outputs terminated with 120 Ω, C <sub>L</sub> = 0 pF	f <sub>O</sub> = 170 MHz		110	140	
			f <sub>O</sub> = 200 MHz		120	150	
		Differential outputs terminated with 120 Ω, C <sub>L</sub> = 14 pF	f <sub>O</sub> = 170 MHz		130	160	
			f <sub>O</sub> = 200 MHz		140	170	
ΔC	Part-to-part input capacitance variation	V <sub>DDQ</sub> = 2.5 V, V <sub>I</sub> = V <sub>DDQ</sub> or GND				1	pF
C <sub>I(Δ)</sub>	Input capacitance difference between CLK and CLK, FBIN and FBIN	V <sub>DDQ</sub> = 2.5 V, V <sub>I</sub> = V <sub>DDQ</sub> or GND				0.25	pF

**TIMING REQUIREMENTS**

over recommended ranges of supply voltage and operating free-air temperature

PARAMETER		MIN	MAX	UNIT
f <sub>CLK</sub>	Operating clock frequency	60	220	MHz
	Application clock frequency	90	220	
Input clock duty cycle		40%	60%	
Stabilization time (PLL mode) <sup>(1)</sup>			10	μs
Stabilization time (bypass mode) <sup>(2)</sup>			30	ns

- (1) The time required for the integrated PLL circuit to obtain phase lock of its feedback signal to its reference signal. For phase lock to be obtained, a fixed-frequency, fixed-phase reference signal must be present at CLK and V<sub>DD</sub> must be applied. Until phase lock is obtained, the specifications for propagation delay, skew, and jitter parameters given in the switching characteristics table are not applicable. This parameter does not apply for input modulation under SSC application.
- (2) A recovery time is required when the device goes from power-down mode into bypass mode (AV<sub>DD</sub> at GND).

**SWITCHING CHARACTERISTICS**

over operating free-air temperature range (unless otherwise noted)

PARAMETER		TEST CONDITIONS	MIN	TYP	MAX	UNIT
$t_{PLH}^{(1)}$	Low- to high-level propagation delay time	Test mode/CLK to any output		3.5		ns
$t_{PHL}^{(1)}$	High- to low-level propagation delay time	Test mode/CLK to any output		3.5		ns
$t_{jit(per)}^{(2)}$	Jitter (period), see Figure 7	100/133/167 MHz (PC1600/2100/2700)	-65		65	ps
		200 MHz (PC3200)	-30		30	
$t_{jit(cc)}^{(2)}$	Jitter (cycle-to-cycle), see Figure 4	100/133/167 MHz (PC1600/2100/2700)	-60		60	ps
		200 MHz (PC3200)	-40		40	
$t_{jit(hper)}^{(2)}$	Half-period jitter, see Figure 8	100/133/167 MHz (PC1600/2100/2700)	-100		100	ps
		200 MHz (PC3200)	-75		75	
$t_{srl(o)}$	Output clock slew rate, see Figure 9	Load: 120 $\Omega$ , 14 pF	1		2	V/ns
$t_{(o)}$	Static phase offset, see Figure 5	100/133/167/200 MHz	-50		50	ps
$t_{sk(o)}$	Output skew, see Figure 6	Load: 120 $\Omega$ , 14 pF; 100/133/167/200 MHz			40	ps

- (1) Refers to the transition of the noninverting output.
- (2) This parameter is assured by design but cannot be 100% production tested.

**PARAMETER MEASUREMENT INFORMATION**

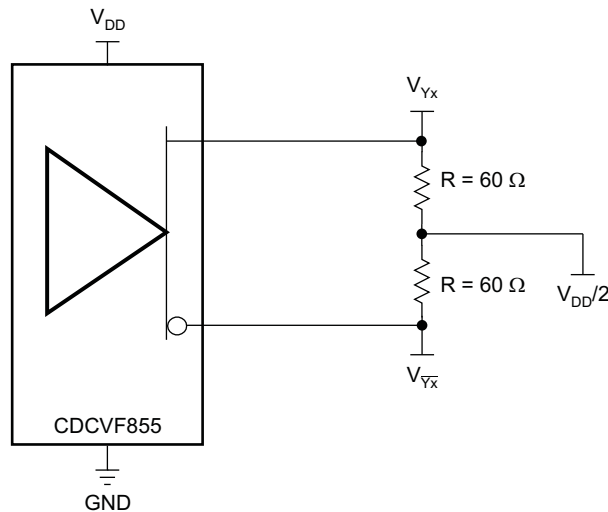

S0229-02

**Figure 1. IBIS Model Output Load**

PARAMETER MEASUREMENT INFORMATION (continued)

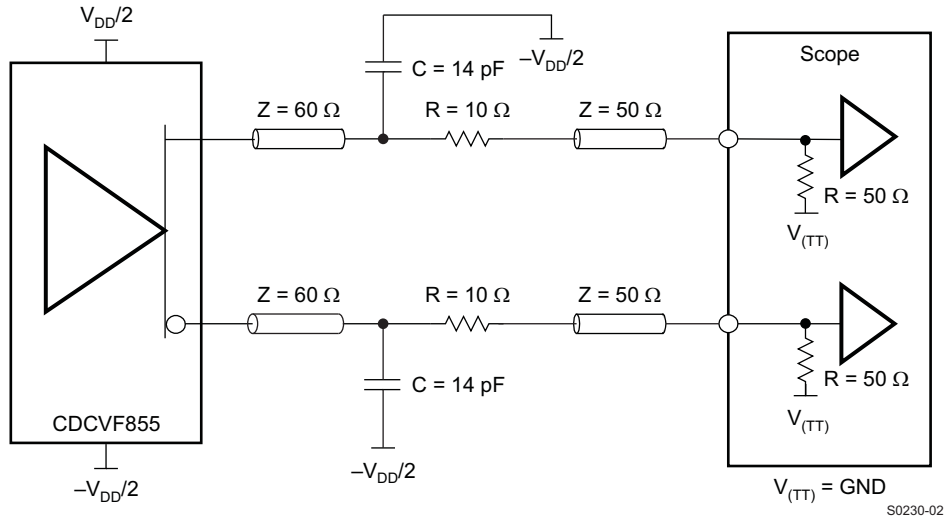

Figure 2. Output Load Test Circuit

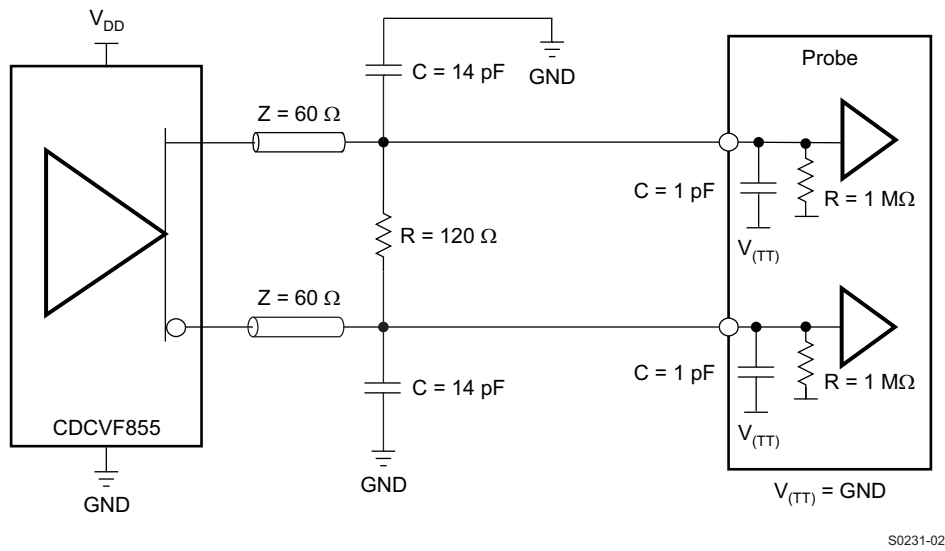
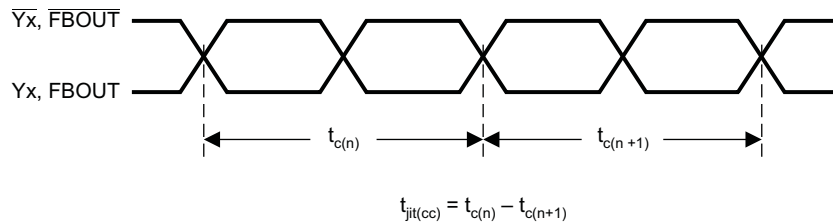

Figure 3. Output Load Test Circuit for Crossing Point



T0174-01

Figure 4. Cycle-to-Cycle Jitter

PARAMETER MEASUREMENT INFORMATION (continued)

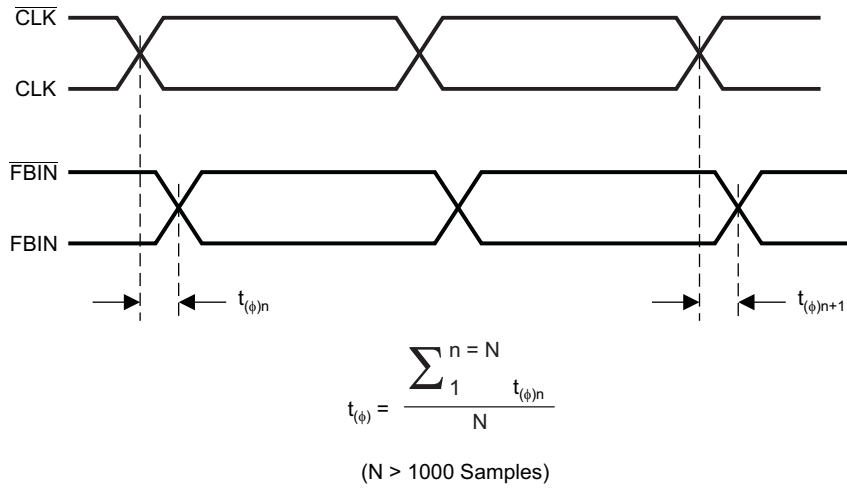

T0175-01

Figure 5. Phase Offset

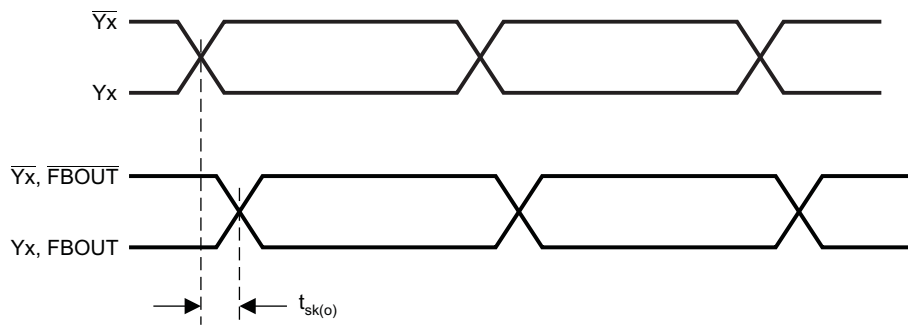

T0176-01

Figure 6. Output Skew

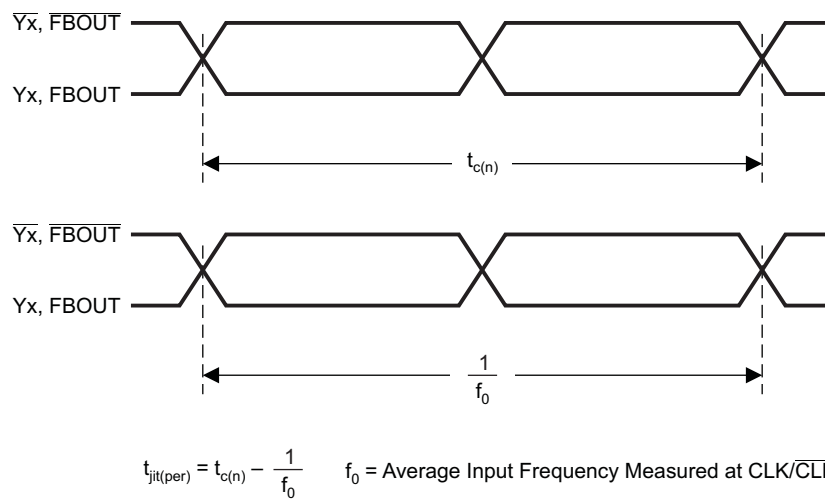

T0177-01

Figure 7. Period Jitter

PARAMETER MEASUREMENT INFORMATION (continued)

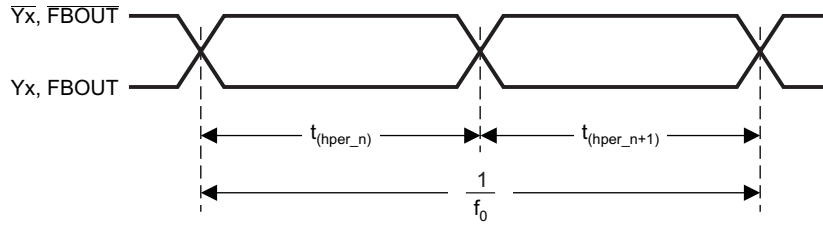

$$t_{jit(hper)} = t_{(hper\_n)} - \frac{1}{2 \times f_0}$$

n = Any Half Cycle  
f<sub>0</sub> = Average Input Frequency Measured at CLK/CLK

T0178-01

Figure 8. Half-Period Jitter

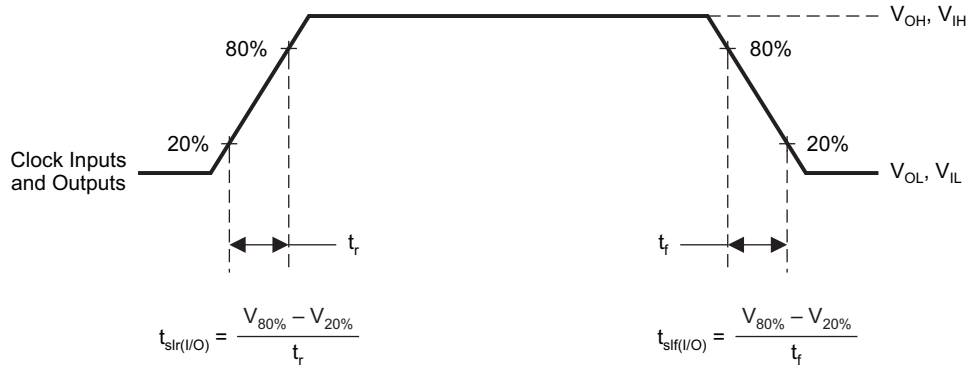

T0179-01

Figure 9. Input and Output Slew Rates

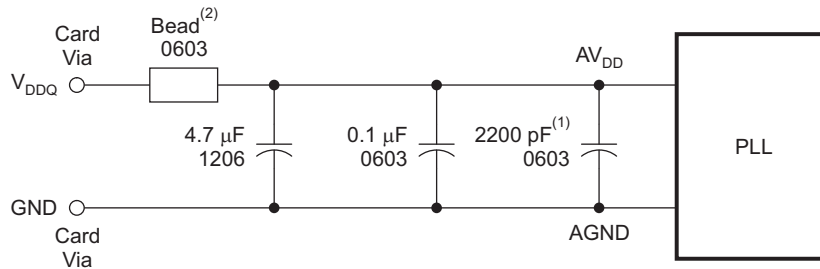

S0232-01

- (1) Place the 2200-pF capacitor close to the PLL.
- (2) Recommended bead: Fair-Rite P/N 2506036017Y0 or equivalent (0.8 Ω dc maximum, 600 Ω at 100 MHz).

NOTE: Use a wide trace for the PLL analog power and ground. Connect PLL and capacitors to AGND trace and connect trace to one GND via (farthest from the PLL).

Figure 10. Recommended AV<sub>DD</sub> Filtering

**PACKAGING INFORMATION**

Orderable Device	Status (1)	Package Type	Package Drawing	Pins	Package Qty	Eco Plan (2)	Lead/Ball Finish (6)	MSL Peak Temp (3)	Op Temp (°C)	Device Marking (4/5)	Samples
CDCVF855PW	ACTIVE	TSSOP	PW	28	50	Green (RoHS & no Sb/Br)	CU NIPDAU	Level-1-260C-UNLIM	-40 to 85	CDCVF855	<a href="#">Samples</a>
CDCVF855PWG4	ACTIVE	TSSOP	PW	28	50	Green (RoHS & no Sb/Br)	CU NIPDAU	Level-1-260C-UNLIM	-40 to 85	CDCVF855	<a href="#">Samples</a>
CDCVF855PWR	ACTIVE	TSSOP	PW	28	2000	Green (RoHS & no Sb/Br)	CU NIPDAU	Level-1-260C-UNLIM	-40 to 85	CDCVF855	<a href="#">Samples</a>
CDCVF855PWRG4	ACTIVE	TSSOP	PW	28	2000	Green (RoHS & no Sb/Br)	CU NIPDAU	Level-1-260C-UNLIM	-40 to 85	CDCVF855	<a href="#">Samples</a>

(1) The marketing status values are defined as follows:

**ACTIVE:** Product device recommended for new designs.

**LIFEBUY:** TI has announced that the device will be discontinued, and a lifetime-buy period is in effect.

**NRND:** Not recommended for new designs. Device is in production to support existing customers, but TI does not recommend using this part in a new design.

**PREVIEW:** Device has been announced but is not in production. Samples may or may not be available.

**OBSOLETE:** TI has discontinued the production of the device.

(2) **RoHS:** TI defines "RoHS" to mean semiconductor products that are compliant with the current EU RoHS requirements for all 10 RoHS substances, including the requirement that RoHS substance do not exceed 0.1% by weight in homogeneous materials. Where designed to be soldered at high temperatures, "RoHS" products are suitable for use in specified lead-free processes. TI may reference these types of products as "Pb-Free".

**RoHS Exempt:** TI defines "RoHS Exempt" to mean products that contain lead but are compliant with EU RoHS pursuant to a specific EU RoHS exemption.

**Green:** TI defines "Green" to mean the content of Chlorine (Cl) and Bromine (Br) based flame retardants meet JS709B low halogen requirements of <=1000ppm threshold. Antimony trioxide based flame retardants must also meet the <=1000ppm threshold requirement.

(3) MSL, Peak Temp. - The Moisture Sensitivity Level rating according to the JEDEC industry standard classifications, and peak solder temperature.

(4) There may be additional marking, which relates to the logo, the lot trace code information, or the environmental category on the device.

(5) Multiple Device Markings will be inside parentheses. Only one Device Marking contained in parentheses and separated by a "-" will appear on a device. If a line is indented then it is a continuation of the previous line and the two combined represent the entire Device Marking for that device.

(6) Lead/Ball Finish - Orderable Devices may have multiple material finish options. Finish options are separated by a vertical ruled line. Lead/Ball Finish values may wrap to two lines if the finish value exceeds the maximum column width.

**Important Information and Disclaimer:** The information provided on this page represents TI's knowledge and belief as of the date that it is provided. TI bases its knowledge and belief on information provided by third parties, and makes no representation or warranty as to the accuracy of such information. Efforts are underway to better integrate information from third parties. TI has taken and

continues to take reasonable steps to provide representative and accurate information but may not have conducted destructive testing or chemical analysis on incoming materials and chemicals. TI and TI suppliers consider certain information to be proprietary, and thus CAS numbers and other limited information may not be available for release.

In no event shall TI's liability arising out of such information exceed the total purchase price of the TI part(s) at issue in this document sold by TI to Customer on an annual basis.

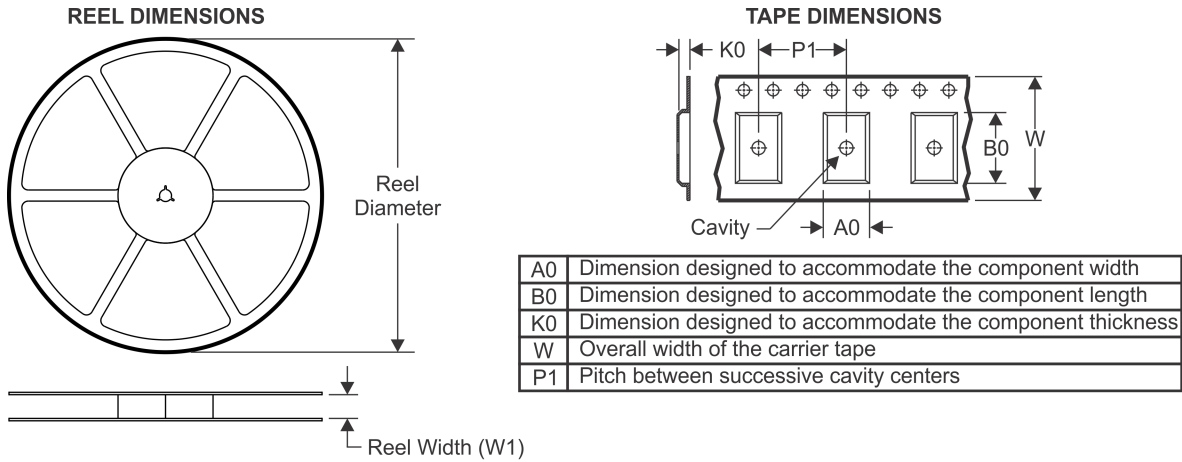
**TAPE AND REEL INFORMATION**

**QUADRANT ASSIGNMENTS FOR PIN 1 ORIENTATION IN TAPE**

\*All dimensions are nominal

Device	Package Type	Package Drawing	Pins	SPQ	Reel Diameter (mm)	Reel Width W1 (mm)	A0 (mm)	B0 (mm)	K0 (mm)	P1 (mm)	W (mm)	Pin1 Quadrant
CDCVF855PWR	TSSOP	PW	28	2000	330.0	16.4	6.9	10.2	1.8	12.0	16.0	Q1

**TAPE AND REEL BOX DIMENSIONS**

\*All dimensions are nominal

Device	Package Type	Package Drawing	Pins	SPQ	Length (mm)	Width (mm)	Height (mm)
CDCVF855PWR	TSSOP	PW	28	2000	367.0	367.0	38.0

PW (R-PDSO-G28)

PLASTIC SMALL OUTLINE

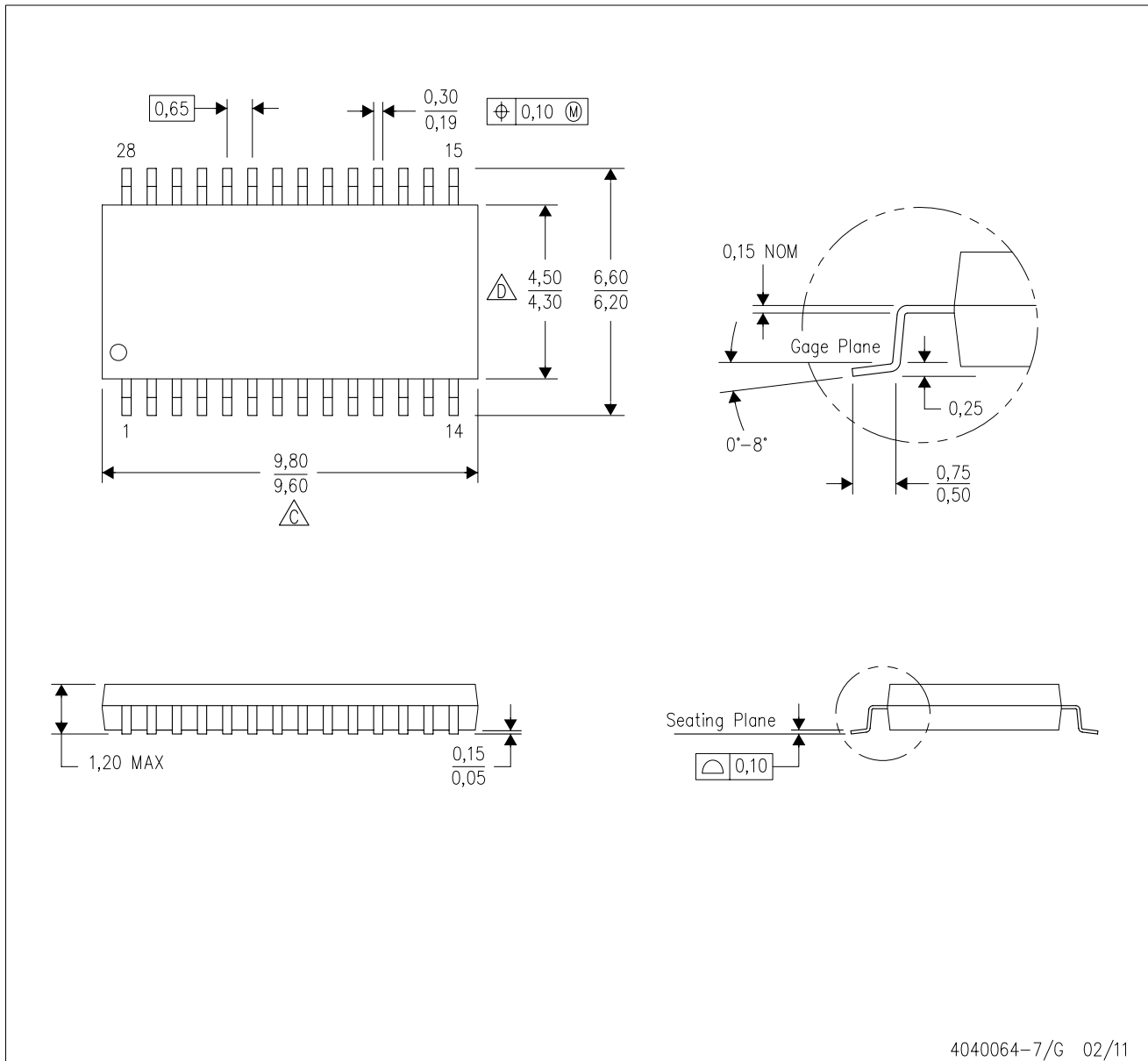

4040064-7/G 02/11

- NOTES:
- A. All linear dimensions are in millimeters. Dimensioning and tolerancing per ASME Y14.5M-1994.
  - B. This drawing is subject to change without notice.
  - C. Body length does not include mold flash, protrusions, or gate burrs. Mold flash, protrusions, or gate burrs shall not exceed 0,15 each side.
  - D. Body width does not include interlead flash. Interlead flash shall not exceed 0,25 each side.
  - E. Falls within JEDEC MO-153

PW (R-PDSO-G28)

PLASTIC SMALL OUTLINE

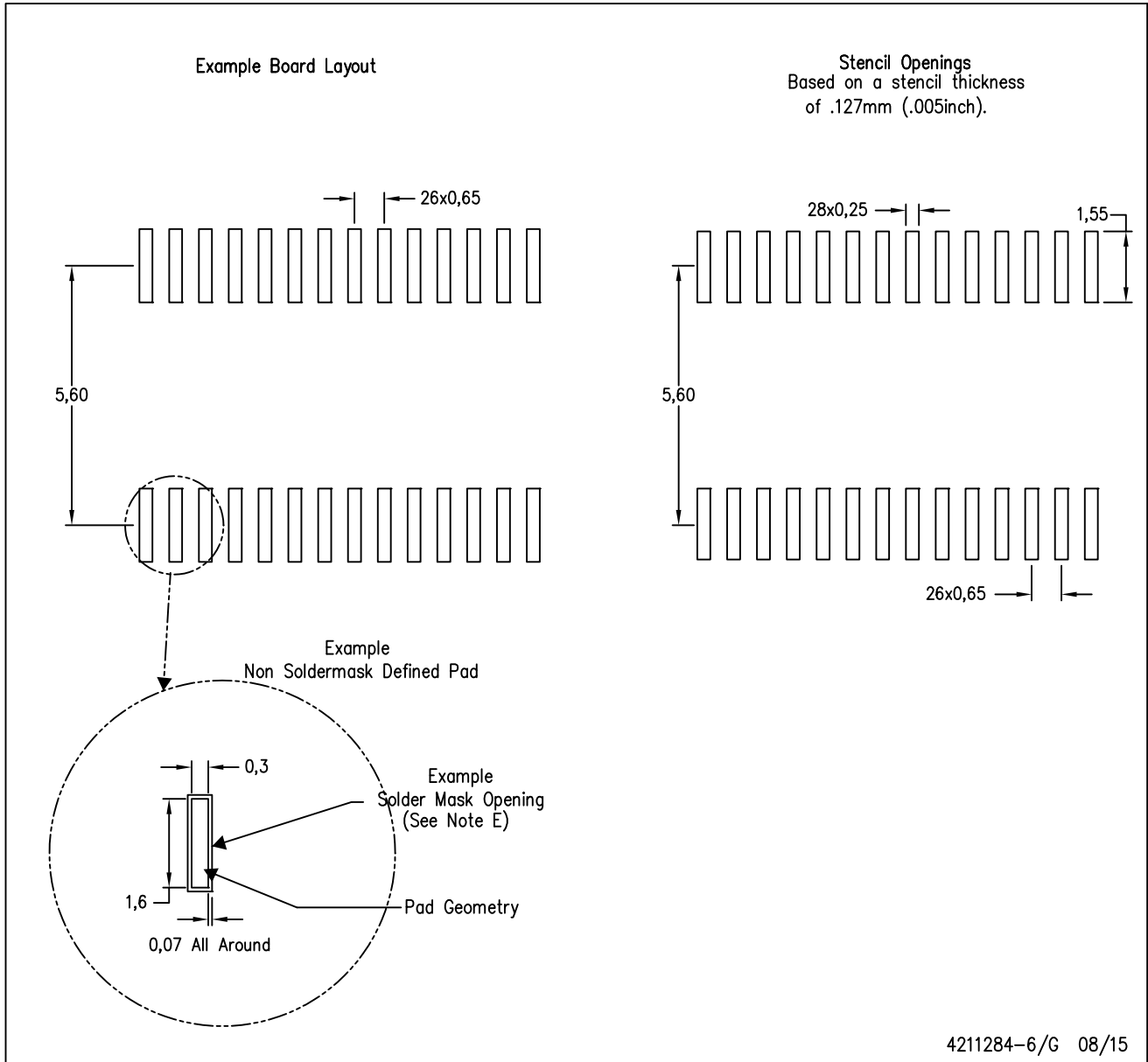

- NOTES:
- A. All linear dimensions are in millimeters.
  - B. This drawing is subject to change without notice.
  - C. Publication IPC-7351 is recommended for alternate design.
  - D. Laser cutting apertures with trapezoidal walls and also rounding corners will offer better paste release. Customers should contact their board assembly site for stencil design recommendations. Refer to IPC-7525 for other stencil recommendations.
  - E. Customers should contact their board fabrication site for solder mask tolerances between and around signal pads.

## IMPORTANT NOTICE

Texas Instruments Incorporated (TI) reserves the right to make corrections, enhancements, improvements and other changes to its semiconductor products and services per JESD46, latest issue, and to discontinue any product or service per JESD48, latest issue. Buyers should obtain the latest relevant information before placing orders and should verify that such information is current and complete.

TI's published terms of sale for semiconductor products (<http://www.ti.com/sc/docs/stdterms.htm>) apply to the sale of packaged integrated circuit products that TI has qualified and released to market. Additional terms may apply to the use or sale of other types of TI products and services.

Reproduction of significant portions of TI information in TI data sheets is permissible only if reproduction is without alteration and is accompanied by all associated warranties, conditions, limitations, and notices. TI is not responsible or liable for such reproduced documentation. Information of third parties may be subject to additional restrictions. Resale of TI products or services with statements different from or beyond the parameters stated by TI for that product or service voids all express and any implied warranties for the associated TI product or service and is an unfair and deceptive business practice. TI is not responsible or liable for any such statements.

Buyers and others who are developing systems that incorporate TI products (collectively, "Designers") understand and agree that Designers remain responsible for using their independent analysis, evaluation and judgment in designing their applications and that Designers have full and exclusive responsibility to assure the safety of Designers' applications and compliance of their applications (and of all TI products used in or for Designers' applications) with all applicable regulations, laws and other applicable requirements. Designer represents that, with respect to their applications, Designer has all the necessary expertise to create and implement safeguards that (1) anticipate dangerous consequences of failures, (2) monitor failures and their consequences, and (3) lessen the likelihood of failures that might cause harm and take appropriate actions. Designer agrees that prior to using or distributing any applications that include TI products, Designer will thoroughly test such applications and the functionality of such TI products as used in such applications.

TI's provision of technical, application or other design advice, quality characterization, reliability data or other services or information, including, but not limited to, reference designs and materials relating to evaluation modules, (collectively, "TI Resources") are intended to assist designers who are developing applications that incorporate TI products; by downloading, accessing or using TI Resources in any way, Designer (individually or, if Designer is acting on behalf of a company, Designer's company) agrees to use any particular TI Resource solely for this purpose and subject to the terms of this Notice.

TI's provision of TI Resources does not expand or otherwise alter TI's applicable published warranties or warranty disclaimers for TI products, and no additional obligations or liabilities arise from TI providing such TI Resources. TI reserves the right to make corrections, enhancements, improvements and other changes to its TI Resources. TI has not conducted any testing other than that specifically described in the published documentation for a particular TI Resource.

Designer is authorized to use, copy and modify any individual TI Resource only in connection with the development of applications that include the TI product(s) identified in such TI Resource. NO OTHER LICENSE, EXPRESS OR IMPLIED, BY ESTOPPEL OR OTHERWISE TO ANY OTHER TI INTELLECTUAL PROPERTY RIGHT, AND NO LICENSE TO ANY TECHNOLOGY OR INTELLECTUAL PROPERTY RIGHT OF TI OR ANY THIRD PARTY IS GRANTED HEREIN, including but not limited to any patent right, copyright, mask work right, or other intellectual property right relating to any combination, machine, or process in which TI products or services are used. Information regarding or referencing third-party products or services does not constitute a license to use such products or services, or a warranty or endorsement thereof. Use of TI Resources may require a license from a third party under the patents or other intellectual property of the third party, or a license from TI under the patents or other intellectual property of TI.

TI RESOURCES ARE PROVIDED "AS IS" AND WITH ALL FAULTS. TI DISCLAIMS ALL OTHER WARRANTIES OR REPRESENTATIONS, EXPRESS OR IMPLIED, REGARDING RESOURCES OR USE THEREOF, INCLUDING BUT NOT LIMITED TO ACCURACY OR COMPLETENESS, TITLE, ANY EPIDEMIC FAILURE WARRANTY AND ANY IMPLIED WARRANTIES OF MERCHANTABILITY, FITNESS FOR A PARTICULAR PURPOSE, AND NON-INFRINGEMENT OF ANY THIRD PARTY INTELLECTUAL PROPERTY RIGHTS. TI SHALL NOT BE LIABLE FOR AND SHALL NOT DEFEND OR INDEMNIFY DESIGNER AGAINST ANY CLAIM, INCLUDING BUT NOT LIMITED TO ANY INFRINGEMENT CLAIM THAT RELATES TO OR IS BASED ON ANY COMBINATION OF PRODUCTS EVEN IF DESCRIBED IN TI RESOURCES OR OTHERWISE. IN NO EVENT SHALL TI BE LIABLE FOR ANY ACTUAL, DIRECT, SPECIAL, COLLATERAL, INDIRECT, PUNITIVE, INCIDENTAL, CONSEQUENTIAL OR EXEMPLARY DAMAGES IN CONNECTION WITH OR ARISING OUT OF TI RESOURCES OR USE THEREOF, AND REGARDLESS OF WHETHER TI HAS BEEN ADVISED OF THE POSSIBILITY OF SUCH DAMAGES.

Unless TI has explicitly designated an individual product as meeting the requirements of a particular industry standard (e.g., ISO/TS 16949 and ISO 26262), TI is not responsible for any failure to meet such industry standard requirements.

Where TI specifically promotes products as facilitating functional safety or as compliant with industry functional safety standards, such products are intended to help enable customers to design and create their own applications that meet applicable functional safety standards and requirements. Using products in an application does not by itself establish any safety features in the application. Designers must ensure compliance with safety-related requirements and standards applicable to their applications. Designer may not use any TI products in life-critical medical equipment unless authorized officers of the parties have executed a special contract specifically governing such use. Life-critical medical equipment is medical equipment where failure of such equipment would cause serious bodily injury or death (e.g., life support, pacemakers, defibrillators, heart pumps, neurostimulators, and implantables). Such equipment includes, without limitation, all medical devices identified by the U.S. Food and Drug Administration as Class III devices and equivalent classifications outside the U.S.

TI may expressly designate certain products as completing a particular qualification (e.g., Q100, Military Grade, or Enhanced Product). Designers agree that it has the necessary expertise to select the product with the appropriate qualification designation for their applications and that proper product selection is at Designers' own risk. Designers are solely responsible for compliance with all legal and regulatory requirements in connection with such selection.

Designer will fully indemnify TI and its representatives against any damages, costs, losses, and/or liabilities arising out of Designer's non-compliance with the terms and provisions of this Notice.

## Looking for pricing, stock, or lifecycle information?

Click below to explore more details on WIN SOURCE:

 [View CDCVF855PWR](#) on WIN SOURCE

 [Texas Instruments](#) Information

## Optimize Your Supply Chain with WIN SOURCE Solutions

-  Global Sourcing Solution
-  Obsolete Management
-  Cost Control Management
-  Shortage Management
-  Alternative Solution
-  Excess Inventory Management