



# DAC9881 18-Bit, Single-Channel, Low-Noise, Voltage-Output Digital-to-Analog Converter

## 1 Features

- 18-Bit Monotonic Over Temperature Range
- Relative Accuracy:  $\pm 2$  LSB Maximum
- Low-Noise: 24 nV/ $\sqrt{\text{Hz}}$
- Fast Settling: 5  $\mu\text{s}$
- On-Chip Output Buffer Amplifier With Rail-to-Rail Operation
- Single Power Supply: 2.7 V to 5.5 V
- DAC Loading Control
- Selectable Power-On Reset to Zero-Scale or Midscale
- Power-Down Mode
- Unipolar Straight Binary or Twos Complement Input Mode
- Fast SPI Interface With Schmitt-Triggered Inputs: up to 50 MHz, 1.8-V, 3-V, and 5-V Logic
- Small Package: VQFN-24, 4 mm  $\times$  4 mm

## 2 Applications

- Automatic Test Equipment
- Precision Instrumentation
- Industrial Controls
- Data Acquisition Systems

## 3 Description

The DAC9881 is an 18-bit, single-channel, voltage-output digital-to-analog converter (DAC). It features 18-bit monotonicity, excellent linearity, very low-noise, and fast settling time. The on-chip precision output amplifier allows rail-to-rail output swing to be achieved over the full supply range of 2.7 V to 5.5 V.

The device supports a standard SPI serial interface capable of operating with input data clock frequencies up to 50 MHz. The DAC9881 requires an external reference voltage to set the output range of the DAC channel. A programmable power-on reset circuit is also incorporated into the device to ensure that the DAC output powers up at zero-scale or midscale, and remains there until a valid write command.

Additionally, the DAC9881 has the capability to function in either unipolar straight binary or twos complement mode. The DAC9881 provides low-power operation. To further save energy, power-down mode can be achieved by accessing the PDN pin, thereby reducing the current consumption to 25  $\mu\text{A}$  at 5 V. Power consumption is 4 mW at 5 V, reducing to 125  $\mu\text{W}$  in power-down mode.

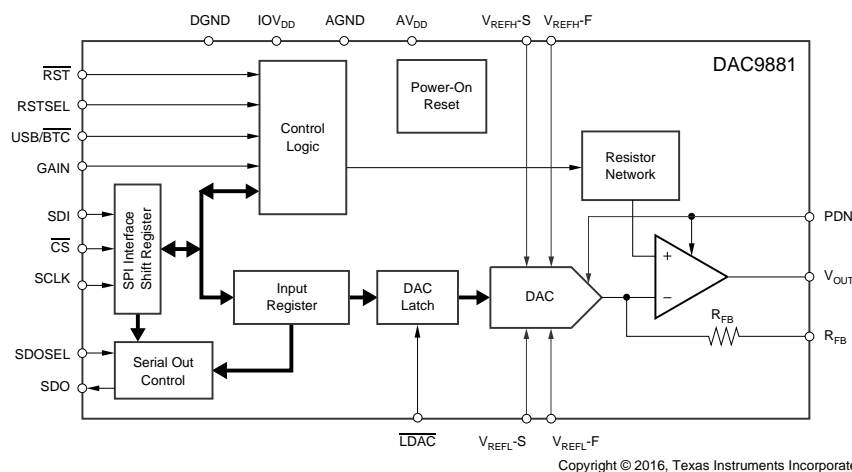
The DAC9881 is available in a 4 mm  $\times$  4 mm VQFN-24 package with a specified temperature range of  $-40^{\circ}\text{C}$  to  $105^{\circ}\text{C}$ .

### Device Information<sup>(1)</sup>

PART NUMBER	PACKAGE	BODY SIZE (NOM)
DAC9881	VQFN (24)	4.00 mm $\times$ 4.00 mm

(1) For all available packages, see the orderable addendum at the end of the data sheet.

### Block Diagram



Copyright © 2016, Texas Instruments Incorporated



## Table of Contents

<b>1 Features</b> .....	<b>1</b>	7.2 Functional Block Diagram .....	<b>27</b>
<b>2 Applications</b> .....	<b>1</b>	7.3 Feature Description .....	<b>27</b>
<b>3 Description</b> .....	<b>1</b>	7.4 Device Functional Modes .....	<b>32</b>
<b>4 Revision History</b> .....	<b>2</b>	<b>8 Application and Implementation</b> .....	<b>33</b>
<b>5 Pin Configuration and Functions</b> .....	<b>3</b>	8.1 Application Information .....	<b>33</b>
<b>6 Specifications</b> .....	<b>4</b>	8.2 Typical Application .....	<b>34</b>
6.1 Absolute Maximum Ratings .....	<b>4</b>	8.3 System Example .....	<b>35</b>
6.2 ESD Ratings .....	<b>4</b>	<b>9 Power Supply Recommendations</b> .....	<b>36</b>
6.3 Recommended Operating Conditions .....	<b>4</b>	<b>10 Layout</b> .....	<b>36</b>
6.4 Thermal Information .....	<b>4</b>	10.1 Layout Guidelines .....	<b>36</b>
6.5 Electrical Characteristics: $V_{DD} = 5\text{ V}$ .....	<b>5</b>	10.2 Layout Example .....	<b>36</b>
6.6 Electrical Characteristics: $V_{DD} = 2.7\text{ V}$ .....	<b>7</b>	<b>11 Device and Documentation Support</b> .....	<b>37</b>
6.7 Timing Requirements—Standalone Operation Without SDO .....	<b>9</b>	11.1 Documentation Support .....	<b>37</b>
6.8 Timing Requirements—Standalone Operation With SDO and Daisy-Chain Mode .....	<b>10</b>	11.2 Receiving Notification of Documentation Updates .....	<b>37</b>
6.9 Typical Characteristics: $V_{DD} = 5\text{ V}$ .....	<b>14</b>	11.3 Community Resource .....	<b>37</b>
6.10 Typical Characteristics: $V_{DD} = 2.7\text{ V}$ .....	<b>21</b>	11.4 Trademarks .....	<b>37</b>
<b>7 Detailed Description</b> .....	<b>25</b>	11.5 Electrostatic Discharge Caution .....	<b>37</b>
7.1 Overview .....	<b>25</b>	11.6 Glossary .....	<b>37</b>
		<b>12 Mechanical, Packaging, and Orderable Information</b> .....	<b>37</b>

## 4 Revision History

NOTE: Page numbers for previous revisions may differ from page numbers in the current version.

### Changes from Revision A (August 2008) to Revision B

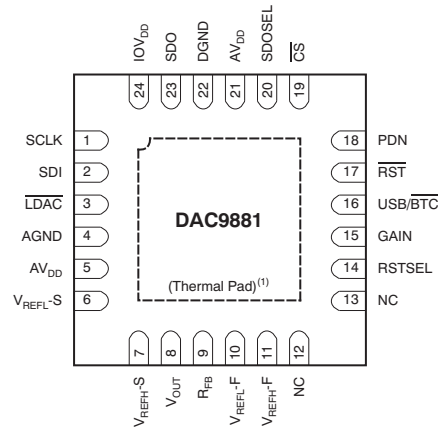
Page

- Added *ESD Ratings* table, *Feature Description* section, *Device Functional Modes*, *Application and Implementation* section, *Power Supply Recommendations* section, *Layout* section, *Device and Documentation Support* section, and *Mechanical, Packaging, and Orderable Information* section .....

1

## 5 Pin Configuration and Functions

**RGE Package**  
**24-Pin VQFN With Exposed Thermal Pad**  
**Top View**



- (1) The thermal pad is internally connected to the substrate. This pad can be connected to the analog ground or left floating. Keep the thermal pad separate from the digital ground, if possible.

### Pin Functions

PIN		I/O	DESCRIPTION
NO.	NAME		
1	SCLK	I	SPI bus serial clock input
2	SDI	I	SPI bus serial data input
3	$\overline{\text{LDAC}}$	I	Load DAC latch control input (active low). When $\overline{\text{LDAC}}$ is low, the DAC latch is transparent, and the contents of the input register are transferred to the DAC latch. The DAC output changes to the corresponding level simultaneously when the DAC latch is updated. It is recommended to connect this pin to IOV <sub>DD</sub> through a pull-up resistor.
4	AGND	I	Analog ground
5	AV <sub>DD</sub>	I	Analog power supply
6	V <sub>REFL-S</sub>	I	Reference low input sense
7	V <sub>REFH-S</sub>	I	Reference high input sense
8	V <sub>OUT</sub>	O	Output of output buffer
9	R <sub>FB</sub>	I	Feedback resistor connected to the inverting input of the output buffer.
10	V <sub>REFL-F</sub>	I	Reference low input force
11	V <sub>REFH-F</sub>	I	Reference high input force
12	NC	—	Do not connect.
13	NC	—	Do not connect.
14	RSTSEL	I	Selects the value of the output from the V <sub>OUT</sub> pin after power-on or hardware reset. If RSTSEL = IOV <sub>DD</sub> , then register data = 20000h. If RSTSEL = DGND, then register data = 00000h.
15	GAIN	I	Buffer gain setting. Gain = 1 when the pin is connected to DGND; Gain = 2 when the pin is connected to IOV <sub>DD</sub> .
16	USB/ $\overline{\text{BTC}}$	I	Input data format selection. Input data are straight binary format when the pin is connected to IOV <sub>DD</sub> , and in twos complement format when the pin is connected to DGND.
17	$\overline{\text{RST}}$	I	Reset input (active low). Logic low on this pin causes the device to perform a reset.
18	PDN	I	Power-down input (active high). Logic high on this pin forces the device into power-down status. In power-down, the V <sub>OUT</sub> pin connects to AGND through a 10k $\Omega$ resistor.
19	$\overline{\text{CS}}$	I	SPI bus chip select input (active low). Data bits are not clocked into the serial shift register unless $\overline{\text{CS}}$ is low. When $\overline{\text{CS}}$ is high, SDO is in a high-impedance state. It is recommended to connect this pin to IOV <sub>DD</sub> through a pull-up resistor.
20	SDOSEL	I	SPI serial data output selection. When SDOSEL is tied to IOV <sub>DD</sub> , the contents of the existing input register are shifted out from the SDO pin; this is Stand-Alone mode. When SDOSEL is tied to DGND, the contents in the SPI input shift register are shifted out from the SDO pin; this is Daisy-Chain mode for daisy-chained communication.
21	AV <sub>DD</sub>	I	Analog power supply. Must be connected to pin 5.
22	DGND	I	Digital ground
23	SDO	O	SPI bus serial data output. Refer to the <i>timing diagrams</i> for further detail.
24	IOV <sub>DD</sub>	I	Interface power. Connect to 1.8 V for 1.8-V logic, 3 V for 3-V logic, and to 5 V for 5-V logic.

## 6 Specifications

### 6.1 Absolute Maximum Ratings

Over operating free-air temperature range (unless otherwise noted).<sup>(1)</sup>

	MIN	MAX	UNIT
$AV_{DD}$ to AGND	-0.3	6	V
$IOV_{DD}$ to DGND	-0.3	6	V
Digital input voltage to DGND	-0.3	$IOV_{DD} + 0.3$	V
$V_{OUT}$ to AGND	-0.3	$AV_{DD} + 0.3$	V
Operating temperature	-40	105	°C
Maximum junction temperature, $T_J$ max		150	°C
Storage temperature, $T_{stg}$	-65	150	°C

(1) Stresses above those listed under *Absolute Maximum Ratings* may cause permanent damage to the device. Exposure to absolute maximum conditions for extended periods may affect device reliability.

### 6.2 ESD Ratings

		VALUE	UNIT
$V_{(ESD)}$ Electrostatic discharge	Human-body model (HBM), per ANSI/ESDA/JEDEC JS-001 <sup>(1)</sup>	±3000	V
	Charged-device model (CDM), per JEDEC specification JESD22-C101 <sup>(2)</sup>	±1000	

(1) JEDEC document JEP155 states that 500-V HBM allows safe manufacturing with a standard ESD control process.

(2) JEDEC document JEP157 states that 250-V CDM allows safe manufacturing with a standard ESD control process.

### 6.3 Recommended Operating Conditions

over operating free-air temperature range (unless otherwise noted)

		MIN	NOM	MAX	UNIT
$AV_{DD}$ Analog power supply		2.7		5.5	V
$IOV_{DD}$ Interface power supply		1.7		$AV_{DD}$	V
$V_{REFH}$ Reference high input voltage	$AV_{DD} = 5.5$ V	1.25	5	$AV_{DD}$	V
	$AV_{DD} = 3$ V	1.25	2.5	$AV_{DD}$	V
$V_{REFL}$ Reference low input voltage		-0.2	0	0.2	V
Specified performance		-40		105	°C

### 6.4 Thermal Information

THERMAL METRIC <sup>(1)</sup>		DAC9881	UNIT
		RGE (VQFN)	
		24 PINS	
$R_{\theta JA}$	Junction-to-ambient thermal resistance	33.5	°C/W
$R_{\theta JC(top)}$	Junction-to-case (top) thermal resistance	37.1	°C/W
$R_{\theta JB}$	Junction-to-board thermal resistance	11.3	°C/W
$\Psi_{JT}$	Junction-to-top characterization parameter	0.5	°C/W
$\Psi_{JB}$	Junction-to-board characterization parameter	11.4	°C/W
$R_{\theta JC(bot)}$	Junction-to-case (bottom) thermal resistance	2	°C/W

(1) For more information about traditional and new thermal metrics, see the *Semiconductor and IC Package Thermal Metrics* application report, (SPRA953).

## 6.5 Electrical Characteristics: $AV_{DD} = 5\text{ V}$

All specifications at  $T_A = T_{MIN}$  to  $T_{MAX}$ ,  $AV_{DD} = 4.75\text{ V}$  to  $5.5\text{ V}$ ,  $IOV_{DD} = 1.8\text{ V}$  to  $5.5\text{ V}$ ,  $V_{REFH} = 5\text{ V}$ ,  $V_{REFL} = 0\text{ V}$ , and gain = 1X mode, unless otherwise noted.

PARAMETER	TEST CONDITIONS		MIN	TYP	MAX	UNIT
<b>ACCURACY<sup>(1)</sup></b>						
Integral linearity error	Measured by line passing through codes 2048 and 260096	DAC9881S		±2	±3	LSB
		DAC9881SB		±1	±2	LSB
Differential linearity error	Measured by line passing through codes 2048 and 260096	DAC9881S	-1	±0.75	+2	LSB
		DAC9881SB		±0.5	±1	LSB
Monotonicity			18			Bits
Zero-scale error	$T_A = 25^\circ\text{C}$ , code = 2048				±16	LSB
	$T_{MIN}$ to $T_{MAX}$ , code = 2048				±32	LSB
Zero-scale drift <sup>(2)</sup>	Code = 2048			±0.25	±0.8	ppm/°C of FSR
Gain error	$T_A = 25^\circ\text{C}$ , measured by line passing through codes 2048 and 260096			±16	±32	LSB
Gain temperature drift <sup>(2)</sup>	Measured by line passing through codes 2048 and 260096			±0.25	±0.4	ppm/°C
PSRR <sup>(2)</sup>	$V_{OUT} = \text{full-scale}$ , $AV_{DD} = 5\text{ V} \pm 10\%$				32	LSB/V
<b>ANALOG OUTPUT<sup>(2)</sup></b>						
Voltage output <sup>(3)</sup>			0		$AV_{DD}$	V
Output voltage drift vs time	Device operating for 500 hours at $25^\circ\text{C}$			0.1		ppm of FSR
	Device operating for 1000 hours at $25^\circ\text{C}$			0.2		ppm of FSR
Output current <sup>(4)</sup>				2.5		mA
Maximum load capacitance				200		pF
Short-circuit current				31–50		mA
<b>REFERENCE INPUT<sup>(2)</sup></b>						
$V_{REFH}$ input voltage range	$AV_{DD} = 5.5\text{ V}$		1.25	5	$AV_{DD}$	V
$V_{REFH}$ input capacitance				5		pF
$V_{REFH}$ input impedance				4.5		kΩ
$V_{REFL}$ input voltage range			-0.2	0	0.2	V
$V_{REFL}$ input capacitance				4.5		pF
$V_{REFL}$ input impedance				5		kΩ
<b>DYNAMIC PERFORMANCE<sup>(2)</sup></b>						
Settling time	To $\pm 0.003\%$ FS, $R_L = 10\text{ k}\Omega$ , $C_L = 50\text{ pF}$ , code 04000h to 3C000h			5		μs
Slew rate	From 10% to 90% of 0 V to 5 V			2.5		V/μs
Code change glitch	Code = 1FFFFh to 20000h to 1FFFFh	$V_{REFH} = 5\text{ V}$ , gain = 1X mode		37		nV-s
		$V_{REFH} = 2.5\text{ V}$ , gain = 1X mode		18		nV-s
		$V_{REFH} = 1.25\text{ V}$ , gain = 1X mode		9		nV-s
		$V_{REFH} = 2.5\text{ V}$ , gain = 2X mode		21		nV-s
		$V_{REFH} = 1.25\text{ V}$ , gain = 2X mode		10		nV-s
Digital feedthrough	$\overline{CS} = \text{high}$ , $f_{SCLK} = 1\text{ kHz}$			1		nV-s
Output noise voltage density	$f = 1\text{ kHz}$ to $100\text{ kHz}$ , full-scale output	Gain = 1		24	30	$\text{nV}/\sqrt{\text{Hz}}$
		Gain = 2		40	48	$\text{nV}/\sqrt{\text{Hz}}$
Output noise voltage	$f = 0.1\text{ Hz}$ to $10\text{ Hz}$ , full-scale output			2		μV <sub>PP</sub>

(1) DAC output range is 0 V to 5 V. 1 LSB = 19 μV.

(2) Ensured by design. Not production tested.

(3) The output from the  $V_{OUT}$  pin =  $[(V_{REFH} - V_{REFL})/262144] \times \text{CODE} \times \text{Buffer GAIN} + V_{REFL}$ . The maximum range of  $V_{OUT}$  is 0 V to  $AV_{DD}$ . The full-scale of the output must be less than  $AV_{DD}$ ; otherwise, output saturation occurs.

(4) See Figure 26, Figure 27, and Figure 28 for details.

**Electrical Characteristics: AV<sub>DD</sub> = 5 V (continued)**

All specifications at T<sub>A</sub> = T<sub>MIN</sub> to T<sub>MAX</sub>, AV<sub>DD</sub> = 4.75 V to 5.5 V, IOV<sub>DD</sub> = 1.8 V to 5.5 V, V<sub>REFH</sub> = 5 V, V<sub>REFL</sub> = 0 V, and gain = 1X mode, unless otherwise noted.

PARAMETER	TEST CONDITIONS	MIN	TYP	MAX	UNIT
<b>DIGITAL INPUTS<sup>(2)</sup></b>					
High-level input voltage, V <sub>IH</sub>	IOV <sub>DD</sub> = 4.5 V to 5.5 V	3.8		IOV <sub>DD</sub> + 0.3	V
	IOV <sub>DD</sub> = 2.7 V to 3.3 V	2.1		IOV <sub>DD</sub> + 0.3	V
	IOV <sub>DD</sub> = 1.7 V to 2 V	1.5		IOV <sub>DD</sub> + 0.3	V
Low-level input voltage, V <sub>IL</sub>	IOV <sub>DD</sub> = 4.5 V to 5.5 V	-0.3		0.8	V
	IOV <sub>DD</sub> = 2.7 V to 3.3 V	-0.3		0.6	V
	IOV <sub>DD</sub> = 1.7 V to 2 V	-0.3		0.3	V
Digital input current (I <sub>IN</sub> )			±1	±10	µA
Digital input capacitance			5		pF
<b>DIGITAL OUTPUT<sup>(2)</sup></b>					
High-level output voltage, V <sub>OH</sub>	IOV <sub>DD</sub> = 2.7 V to 5.5 V, I <sub>OH</sub> = -1 mA	IOV <sub>DD</sub> - 0.2			V
	IOV <sub>DD</sub> = 1.7 V to 2 V, I <sub>OH</sub> = -500 µA	IOV <sub>DD</sub> - 0.2			V
Low-level output voltage, V <sub>OL</sub>	IOV <sub>DD</sub> = 2.7V to 5.5 V, I <sub>OL</sub> = 1 mA			0.2	V
	IOV <sub>DD</sub> = 1.7 V to 2 V, I <sub>OL</sub> = 500 µA			0.2	V
<b>POWER SUPPLY</b>					
AV <sub>DD</sub>		4.75	5	5.5	V
IOV <sub>DD</sub>		1.7		AV <sub>DD</sub>	V
AI <sub>DD</sub>	V <sub>IH</sub> = IOV <sub>DD</sub> , V <sub>IL</sub> = DGND		0.85	1.5	mA
IOI <sub>DD</sub>	V <sub>IH</sub> = IOV <sub>DD</sub> , V <sub>IL</sub> = DGND		1	10	µA
AI <sub>DD</sub> power-down	PDN pin = IOV <sub>DD</sub>		25	50	µA
Power dissipation	AV <sub>DD</sub> = 5 V		4.3	7.5	mW
<b>TEMPERATURE RANGE</b>					
Specified performance		-40		105	°C

## 6.6 Electrical Characteristics: $AV_{DD} = 2.7\text{ V}$

All specifications at  $T_A = T_{MIN}$  to  $T_{MAX}$ ,  $AV_{DD} = 2.7\text{ V}$  to  $3.3\text{ V}$ ,  $IOV_{DD} = 1.8\text{ V}$  to  $AV_{DD}$ ,  $V_{REFH} = 2.5\text{ V}$ ,  $V_{REFL} = 0\text{ V}$  and gain = 1X mode, unless otherwise noted.

PARAMETER	TEST CONDITIONS	MIN	TYP	MAX	UNIT
<b>ACCURACY<sup>(1)</sup></b>					
Integral linearity error	Measured by line passing through codes 2048 and 262143	DAC9881S	±2.5	±3.5	LSB
		DAC9881SB	±2	±3	LSB
Differential linearity error	Measured by line passing through codes 2048 and 262143	DAC9881S	±1	±2	LSB
		DAC9881SB	±0.75	±1.5	LSB
Zero-scale error	$T_A = 25^\circ\text{C}$ , code = 2048			±32	LSB
	$T_{MIN}$ to $T_{MAX}$ , code = 2048			±64	LSB
Zero-scale drift <sup>(2)</sup>	Code = 2048		±0.5	±1.6	ppm/°C of FSR
Gain error	$T_A = 25^\circ\text{C}$ , measured by line passing through codes 2048 and 262143		±32	±64	LSB
Gain temperature drift <sup>(2)</sup>	Measured by line passing through codes 2048 and 262143		±0.5	±0.8	ppm/°C
PSRR <sup>(2)</sup>	$V_{OUT} = \text{full-scale}$ , $AV_{DD} = 3\text{ V} \pm 10\%$			64	LSB/V
<b>ANALOG OUTPUT<sup>(2)</sup></b>					
Voltage output <sup>(3)</sup>		0		$AV_{DD}$	V
Output voltage drift vs time	Device operating for 500 hours at $25^\circ\text{C}$		0.2		ppm of FSR
	Device operating for 1000 hours at $25^\circ\text{C}$		0.4		ppm of FSR
Output current <sup>(4)</sup>			2.5		mA
Maximum load capacitance			200		pF
Short-circuit current			31–50		mA
<b>REFERENCE INPUT<sup>(2)</sup></b>					
$V_{REFH}$ input voltage range	$AV_{DD} = 3\text{ V}$	1.25	2.5	$AV_{DD}$	V
$V_{REFH}$ input capacitance			5		pF
$V_{REFH}$ input impedance			4.5		kΩ
$V_{REFL}$ input voltage range		–0.2	0	0.2	V
$V_{REFL}$ input capacitance			4.5		pF
$V_{REFL}$ input impedance			5		kΩ
<b>DYNAMIC PERFORMANCE<sup>(2)</sup></b>					
Settling time	To ±0.003% FS, $R_L = 10\text{ k}\Omega$ , $C_L = 50\text{ pF}$ , code 04000h to 3C000h		5		μs
Slew rate	From 10% to 90% of 0 V to 2.5 V		2.5		V/μs
Code change glitch	Code = 1FFFFh to 20000h to 1FFFFh	$V_{REFH} = 2.5\text{ V}$ , gain = 1X mode	18		nV-s
		$V_{REFH} = 1.25\text{ V}$ , gain = 1X mode	9		nV-s
		$V_{REFH} = 1.25\text{ V}$ , gain = 2X mode	10		nV-s
Digital feedthrough	$\overline{CS} = \text{high}$ , $f_{SCLK} = 1\text{ kHz}$		1		nV-s
Output noise voltage density	$f = 1\text{ kHz}$ to $100\text{ kHz}$ , full-scale output	Gain = 1	24	30	$\text{nV}/\sqrt{\text{Hz}}$
		Gain = 2	40	48	$\text{nV}/\sqrt{\text{Hz}}$
Output noise voltage	$f = 0.1\text{ Hz}$ to $10\text{ Hz}$ , full-scale output		2		μV <sub>PP</sub>

(1) DAC output range is 0 V to 2.5 V. 1 LSB = 9.5 μV.

(2) Ensured by design. Not production tested.

(3) The output from the  $V_{OUT}$  pin is  $[(V_{REFH} - V_{REFL})/262144] \times \text{CODE} \times \text{Buffer GAIN} + V_{REFL}$ . The maximum range of  $V_{OUT}$  is 0 V to  $AV_{DD}$ . The full-scale of the output must be less than  $AV_{DD}$ ; otherwise, output saturation occurs.

(4) See Figure 55, Figure 56, and Figure 57 for details.

**Electrical Characteristics: AV<sub>DD</sub> = 2.7 V (continued)**

All specifications at T<sub>A</sub> = T<sub>MIN</sub> to T<sub>MAX</sub>, AV<sub>DD</sub> = 2.7 V to 3.3 V, IOV<sub>DD</sub> = 1.8 V to AV<sub>DD</sub>, V<sub>REFH</sub> = 2.5 V, V<sub>REFL</sub> = 0 V and gain = 1X mode, unless otherwise noted.

PARAMETER	TEST CONDITIONS	MIN	TYP	MAX	UNIT
<b>DIGITAL INPUTS<sup>(2)</sup></b>					
High-level input voltage, V <sub>IH</sub>	IOV <sub>DD</sub> = 2.7 V to 3.3 V	2.1		IOV <sub>DD</sub> + 0.3	V
	IOV <sub>DD</sub> = 1.7 V to 2 V	1.5		IOV <sub>DD</sub> + 0.3	V
Low-level input voltage, V <sub>IL</sub>	IOV <sub>DD</sub> = 2.7 V to 3.3 V	-0.3		0.6	V
	IOV <sub>DD</sub> = 1.7 V to 2 V	-0.3		0.3	V
Digital input current (I <sub>IN</sub> )			±1	±10	µA
Digital input capacitance			5		pF
<b>DIGITAL OUTPUT<sup>(2)</sup></b>					
High-level output voltage, V <sub>OH</sub>	IOV <sub>DD</sub> = 2.7 V to 3.3 V, I <sub>OH</sub> = -1 mA	IOV <sub>DD</sub> - 0.2			V
	IOV <sub>DD</sub> = 1.7 V to 2 V, I <sub>OH</sub> = -500 µA	IOV <sub>DD</sub> - 0.2			V
Low-level output voltage, V <sub>OL</sub>	IOV <sub>DD</sub> = 2.7 V to 3.3 V, I <sub>OL</sub> = 1 mA			0.2	V
	IOV <sub>DD</sub> = 1.7 to 2 V, I <sub>OL</sub> = 500 µA			0.2	V
<b>POWER SUPPLY</b>					
AV <sub>DD</sub>		2.7	3	3.3	V
IOV <sub>DD</sub>		1.7		AV <sub>DD</sub>	V
AI <sub>DD</sub>	V <sub>IH</sub> = IOV <sub>DD</sub> , V <sub>IL</sub> = DGND		0.75	1.2	mA
IOI <sub>DD</sub>	V <sub>IH</sub> = IOV <sub>DD</sub> , V <sub>IL</sub> = DGND		1	10	µA
AI <sub>DD</sub> power-down	PDN pin = IOV <sub>DD</sub>		25	50	µA
Power dissipation	AV <sub>DD</sub> = 3 V		2.3	3.6	mW
<b>TEMPERATURE RANGE</b>					
Specified performance		-40		105	°C

## 6.7 Timing Requirements—Standalone Operation Without SDO

At  $-40^{\circ}\text{C}$  to  $+105^{\circ}\text{C}$ , unless otherwise noted. See [Figure 1](#) <sup>(1)(2)(3)</sup>

			MIN	MAX	UNIT
f <sub>SCLK</sub>	Maximum clock frequency	$2.7 \leq AV_{DD} < 3.6 \text{ V}, 2.7 \leq IOV_{DD} \leq AV_{DD}$		40	MHz
		$3.6 \leq AV_{DD} \leq 5.5 \text{ V}, 2.7 \leq IOV_{DD} \leq AV_{DD}$		50	MHz
t <sub>1</sub>	Minimum $\overline{CS}$ high time	$2.7 \leq AV_{DD} < 3.6 \text{ V}, 2.7 \leq IOV_{DD} \leq AV_{DD}$	50		ns
		$3.6 \leq AV_{DD} \leq 5.5 \text{ V}, 2.7 \leq IOV_{DD} \leq AV_{DD}$	30		ns
t <sub>2</sub>	Delay from $\overline{CS}$ falling edge to SCLK rising edge	$2.7 \leq AV_{DD} < 3.6 \text{ V}, 2.7 \leq IOV_{DD} \leq AV_{DD}$	10		ns
		$3.6 \leq AV_{DD} \leq 5.5 \text{ V}, 2.7 \leq IOV_{DD} \leq AV_{DD}$	8		ns
t <sub>3</sub>	Delay from SCLK falling edge to $\overline{CS}$ falling edge	$2.7 \leq AV_{DD} < 3.6 \text{ V}, 2.7 \leq IOV_{DD} \leq AV_{DD}$	0		ns
		$3.6 \leq AV_{DD} \leq 5.5 \text{ V}, 2.7 \leq IOV_{DD} \leq AV_{DD}$	0		ns
t <sub>4</sub>	SCLK low time	$2.7 \leq AV_{DD} < 3.6 \text{ V}, 2.7 \leq IOV_{DD} \leq AV_{DD}$	10		ns
		$3.6 \leq AV_{DD} \leq 5.5 \text{ V}, 2.7 \leq IOV_{DD} \leq AV_{DD}$	10		ns
t <sub>5</sub>	SCLK high time	$2.7 \leq AV_{DD} < 3.6 \text{ V}, 2.7 \leq IOV_{DD} \leq AV_{DD}$	15		ns
		$3.6 \leq AV_{DD} \leq 5.5 \text{ V}, 2.7 \leq IOV_{DD} \leq AV_{DD}$	10		ns
t <sub>6</sub>	SCLK cycle time	$2.7 \leq AV_{DD} < 3.6 \text{ V}, 2.7 \leq IOV_{DD} \leq AV_{DD}$	25		ns
		$3.6 \leq AV_{DD} \leq 5.5 \text{ V}, 2.7 \leq IOV_{DD} \leq AV_{DD}$	20		ns
t <sub>7</sub>	Delay from SCLK rising edge to $\overline{CS}$ rising edge	$2.7 \leq AV_{DD} < 3.6 \text{ V}, 2.7 \leq IOV_{DD} \leq AV_{DD}$	10		ns
		$3.6 \leq AV_{DD} \leq 5.5 \text{ V}, 2.7 \leq IOV_{DD} \leq AV_{DD}$	10		ns
t <sub>8</sub>	Input data setup time	$2.7 \leq AV_{DD} < 3.6 \text{ V}, 2.7 \leq IOV_{DD} \leq AV_{DD}$	8		ns
		$3.6 \leq AV_{DD} \leq 5.5 \text{ V}, 2.7 \leq IOV_{DD} \leq AV_{DD}$	5		ns
t <sub>9</sub>	Input data hold time	$2.7 \leq AV_{DD} < 3.6 \text{ V}, 2.7 \leq IOV_{DD} \leq AV_{DD}$	5		ns
		$3.6 \leq AV_{DD} \leq 5.5 \text{ V}, 2.7 \leq IOV_{DD} \leq AV_{DD}$	5		ns
t <sub>14</sub>	Delay from $\overline{CS}$ rising edge to $\overline{LDAC}$ falling edge	$2.7 \leq AV_{DD} < 3.6 \text{ V}, 2.7 \leq IOV_{DD} \leq AV_{DD}$	10		ns
		$3.6 \leq AV_{DD} \leq 5.5 \text{ V}, 2.7 \leq IOV_{DD} \leq AV_{DD}$	5		ns
t <sub>15</sub>	$\overline{LDAC}$ pulse width	$2.7 \leq AV_{DD} < 3.6 \text{ V}, 2.7 \leq IOV_{DD} \leq AV_{DD}$	15		ns
		$3.6 \leq AV_{DD} \leq 5.5 \text{ V}, 2.7 \leq IOV_{DD} \leq AV_{DD}$	10		ns

- (1) All input signals are specified with  $t_R = t_F = 2\text{ns}$  (10% to 90% of  $IOV_{DD}$ ) and timed from a voltage level of  $IOV_{DD}/2$ .
- (2) Ensured by design. Not production tested.
- (3) Sample tested during the initial release and after any redesign or process changes that may affect these parameters.

## 6.8 Timing Requirements—Standalone Operation With SDO and Daisy-Chain Mode

At  $-40^{\circ}\text{C}$  to  $105^{\circ}\text{C}$ , unless otherwise noted. See [Figure 2](#) and [Figure 3](#)<sup>(1)(2)(3)</sup>.

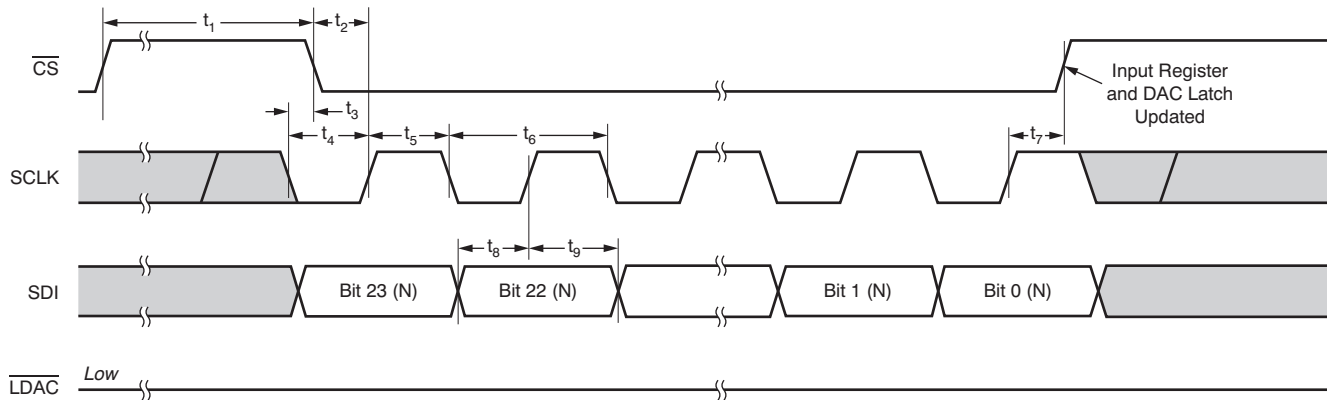
		MIN	MAX	UNIT
$f_{\text{SCLK}}$	Maximum clock frequency	$2.7 \leq AV_{\text{DD}} < 3.6 \text{ V}, 2.7 \leq IOV_{\text{DD}} \leq AV_{\text{DD}}$	20	MHz
		$3.6 \leq AV_{\text{DD}} \leq 5.5 \text{ V}, 2.7 \leq IOV_{\text{DD}} \leq AV_{\text{DD}}$	25	MHz
$t_1$	Minimum $\overline{\text{CS}}$ high time	$2.7 \leq AV_{\text{DD}} < 3.6 \text{ V}, 2.7 \leq IOV_{\text{DD}} \leq AV_{\text{DD}}$	50	ns
		$3.6 \leq AV_{\text{DD}} \leq 5.5 \text{ V}, 2.7 \leq IOV_{\text{DD}} \leq AV_{\text{DD}}$	30	ns
$t_2$	Delay from $\overline{\text{CS}}$ falling edge to SCLK rising edge	$2.7 \leq AV_{\text{DD}} < 3.6 \text{ V}, 2.7 \leq IOV_{\text{DD}} \leq AV_{\text{DD}}$	10	ns
		$3.6 \leq AV_{\text{DD}} \leq 5.5 \text{ V}, 2.7 \leq IOV_{\text{DD}} \leq AV_{\text{DD}}$	8	ns
$t_3$	Delay from SCLK falling edge to $\overline{\text{CS}}$ falling edge	$2.7 \leq AV_{\text{DD}} < 3.6 \text{ V}, 2.7 \leq IOV_{\text{DD}} \leq AV_{\text{DD}}$	0	ns
		$3.6 \leq AV_{\text{DD}} \leq 5.5 \text{ V}, 2.7 \leq IOV_{\text{DD}} \leq AV_{\text{DD}}$	0	ns
$t_4$	SCLK low time	$2.7 \leq AV_{\text{DD}} < 3.6 \text{ V}, 2.7 \leq IOV_{\text{DD}} \leq AV_{\text{DD}}$	25	ns
		$3.6 \leq AV_{\text{DD}} \leq 5.5 \text{ V}, 2.7 \leq IOV_{\text{DD}} \leq AV_{\text{DD}}$	20	ns
$t_5$	SCLK high time	$2.7 \leq AV_{\text{DD}} < 3.6 \text{ V}, 2.7 \leq IOV_{\text{DD}} \leq AV_{\text{DD}}$	25	ns
		$3.6 \leq AV_{\text{DD}} \leq 5.5 \text{ V}, 2.7 \leq IOV_{\text{DD}} \leq AV_{\text{DD}}$	20	ns
$t_6$	SCLK cycle time	$2.7 \leq AV_{\text{DD}} < 3.6 \text{ V}, 2.7 \leq IOV_{\text{DD}} \leq AV_{\text{DD}}$	50	ns
		$3.6 \leq AV_{\text{DD}} \leq 5.5 \text{ V}, 2.7 \leq IOV_{\text{DD}} \leq AV_{\text{DD}}$	40	ns
$t_7$	Delay from SCLK rising edge to $\overline{\text{CS}}$ rising edge	$2.7 \leq AV_{\text{DD}} < 3.6 \text{ V}, 2.7 \leq IOV_{\text{DD}} \leq AV_{\text{DD}}$	10	ns
		$3.6 \leq AV_{\text{DD}} \leq 5.5 \text{ V}, 2.7 \leq IOV_{\text{DD}} \leq AV_{\text{DD}}$	10	ns
$t_8$	Input data setup time	$2.7 \leq AV_{\text{DD}} < 3.6 \text{ V}, 2.7 \leq IOV_{\text{DD}} \leq AV_{\text{DD}}$	5	ns
		$3.6 \leq AV_{\text{DD}} \leq 5.5 \text{ V}, 2.7 \leq IOV_{\text{DD}} \leq AV_{\text{DD}}$	5	ns
$t_9$	Input data hold time	$2.7 \leq AV_{\text{DD}} < 3.6 \text{ V}, 2.7 \leq IOV_{\text{DD}} \leq AV_{\text{DD}}$	5	ns
		$3.6 \leq AV_{\text{DD}} \leq 5.5 \text{ V}, 2.7 \leq IOV_{\text{DD}} \leq AV_{\text{DD}}$	5	ns
$t_{10}$	Delay from $\overline{\text{CS}}$ falling edge to SDO valid	$2.7 \leq AV_{\text{DD}} < 3.6 \text{ V}, 2.7 \leq IOV_{\text{DD}} \leq AV_{\text{DD}}$	15	ns
		$3.6 \leq AV_{\text{DD}} \leq 5.5 \text{ V}, 2.7 \leq IOV_{\text{DD}} \leq AV_{\text{DD}}$	10	ns
$t_{11}$	Delay from SCLK falling edge to SDO valid	$2.7 \leq AV_{\text{DD}} < 3.6 \text{ V}, 2.7 \leq IOV_{\text{DD}} \leq AV_{\text{DD}}$	20	ns
		$3.6 \leq AV_{\text{DD}} \leq 5.5 \text{ V}, 2.7 \leq IOV_{\text{DD}} \leq AV_{\text{DD}}$	15	ns
$t_{12}$	SDO data hold from SCLK rising edge	$2.7 \leq AV_{\text{DD}} < 3.6 \text{ V}, 2.7 \leq IOV_{\text{DD}} \leq AV_{\text{DD}}$	$t_5$	ns
		$3.6 \leq AV_{\text{DD}} \leq 5.5 \text{ V}, 2.7 \leq IOV_{\text{DD}} \leq AV_{\text{DD}}$	$t_5$	ns
$t_{13}$	Delay from $\overline{\text{CS}}$ rising edge to SDO high-Z	$2.7 \leq AV_{\text{DD}} < 3.6 \text{ V}, 2.7 \leq IOV_{\text{DD}} \leq AV_{\text{DD}}$	8	ns
		$3.6 \leq AV_{\text{DD}} \leq 5.5 \text{ V}, 2.7 \leq IOV_{\text{DD}} \leq AV_{\text{DD}}$	5	ns
$t_{14}$	Delay from $\overline{\text{CS}}$ rising edge to $\overline{\text{LDAC}}$ falling edge	$2.7 \leq AV_{\text{DD}} < 3.6 \text{ V}, 2.7 \leq IOV_{\text{DD}} \leq AV_{\text{DD}}$	10	ns
		$3.6 \leq AV_{\text{DD}} \leq 5.5 \text{ V}, 2.7 \leq IOV_{\text{DD}} \leq AV_{\text{DD}}$	5	ns
$t_{15}$	$\overline{\text{LDAC}}$ pulse width	$2.7 \leq AV_{\text{DD}} < 3.6 \text{ V}, 2.7 \leq IOV_{\text{DD}} \leq AV_{\text{DD}}$	15	ns
		$3.6 \leq AV_{\text{DD}} \leq 5.5 \text{ V}, 2.7 \leq IOV_{\text{DD}} \leq AV_{\text{DD}}$	10	ns

(1) All input signals are specified with  $t_{\text{R}} = t_{\text{F}} = 2\text{ns}$  (10% to 90% of  $IOV_{\text{DD}}$ ) and timed from a voltage level of  $IOV_{\text{DD}}/2$ .

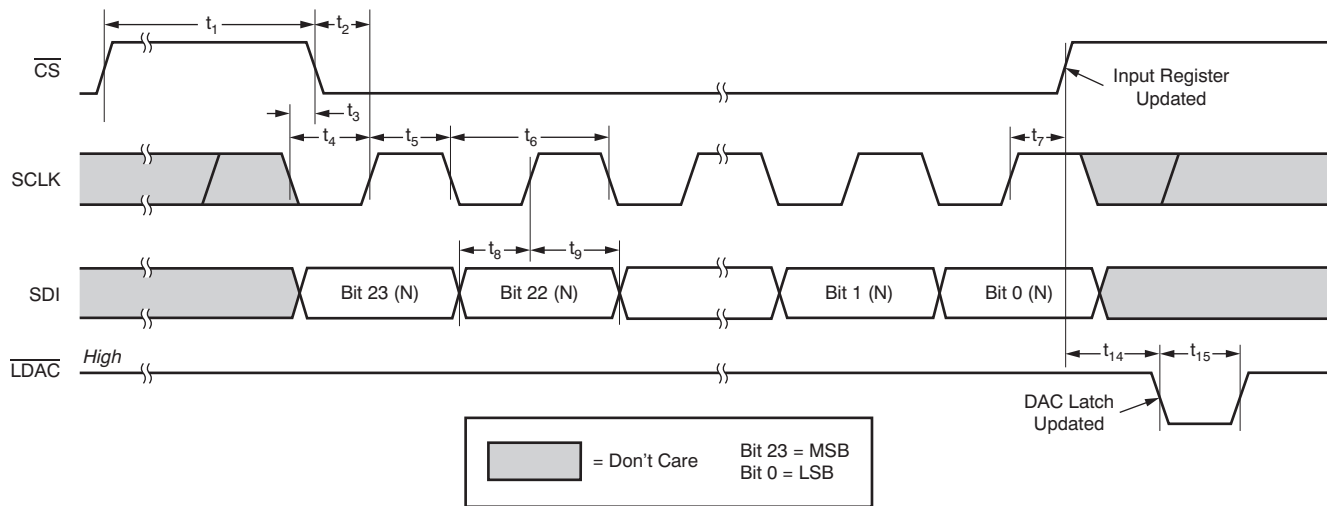
(2) Ensured by design. Not production tested.

(3) Sample tested during the initial release and after any redesign or process changes that may affect these parameters.

**Case 1: Standalone operation without SDO,  $\overline{\text{LDAC}}$  tied low.**

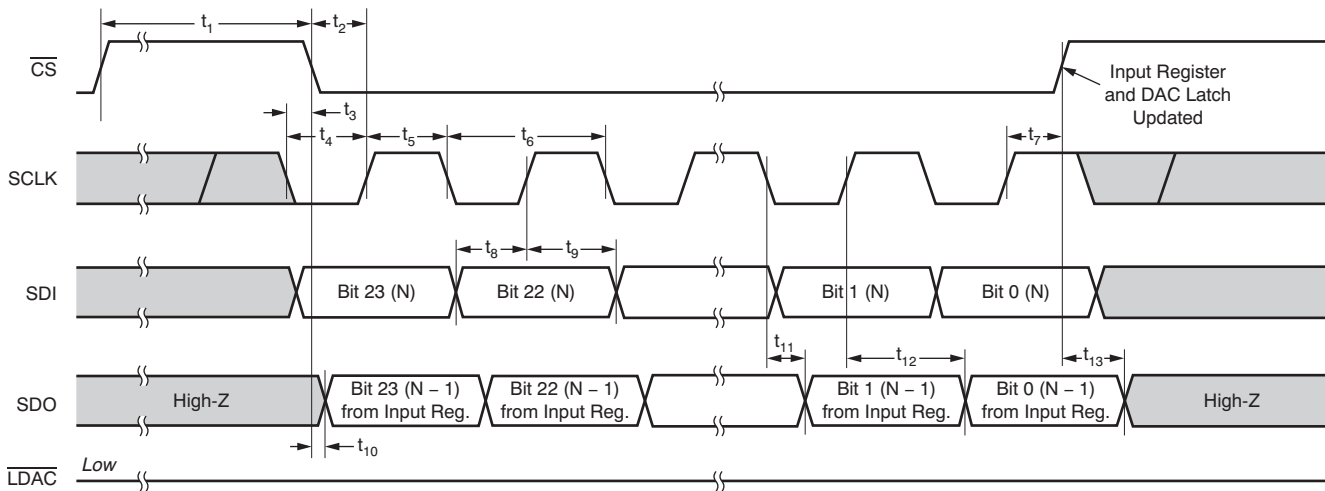


**Case 2: Standalone operation without SDO,  $\overline{\text{LDAC}}$  active.**

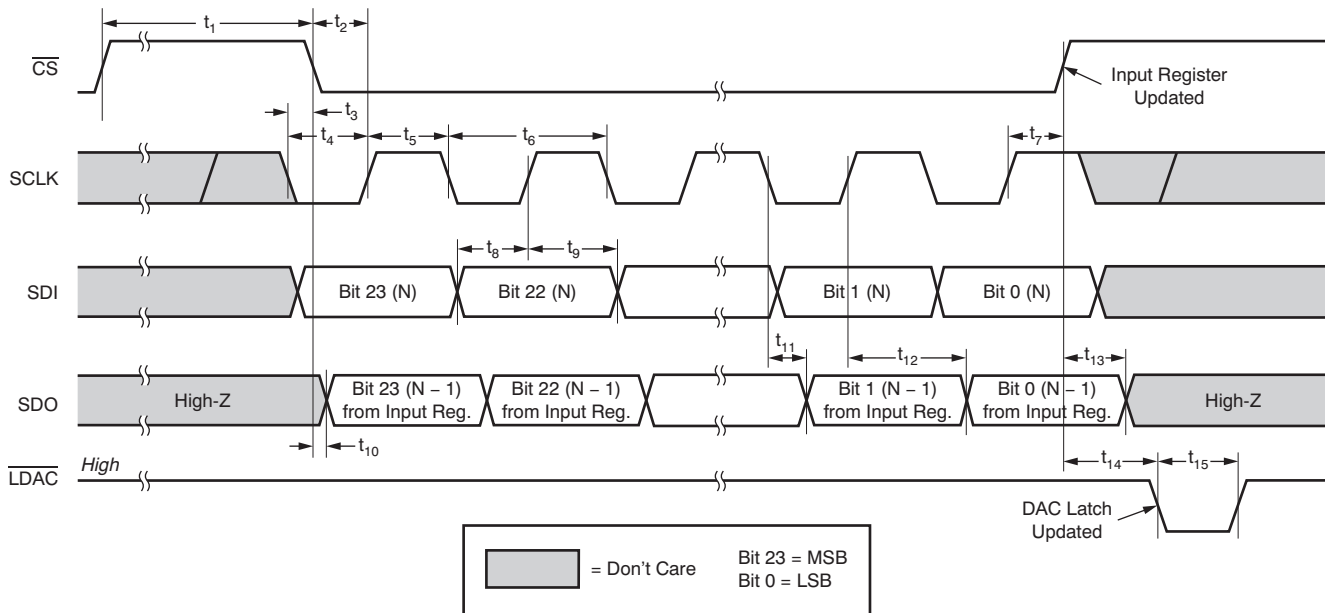


**Figure 1. Timing Diagram for Standalone Operation without SDO**

**Case 1: Standalone operation with output from SDO,  $\overline{\text{LDAC}}$  tied low.**

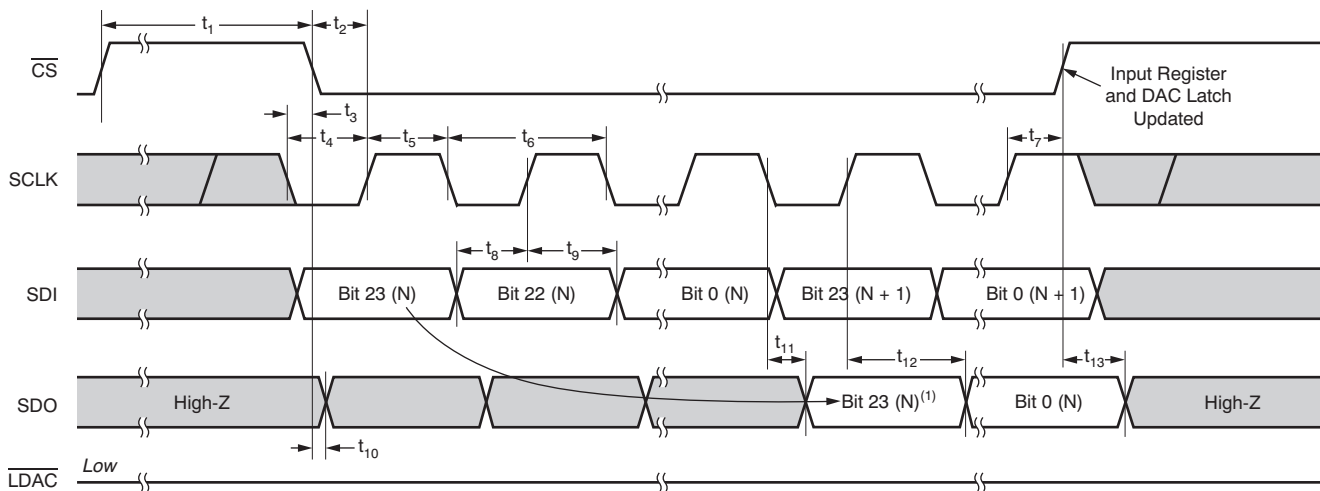


**Case 2: Standalone operation with output from SDO,  $\overline{\text{LDAC}}$  active.**

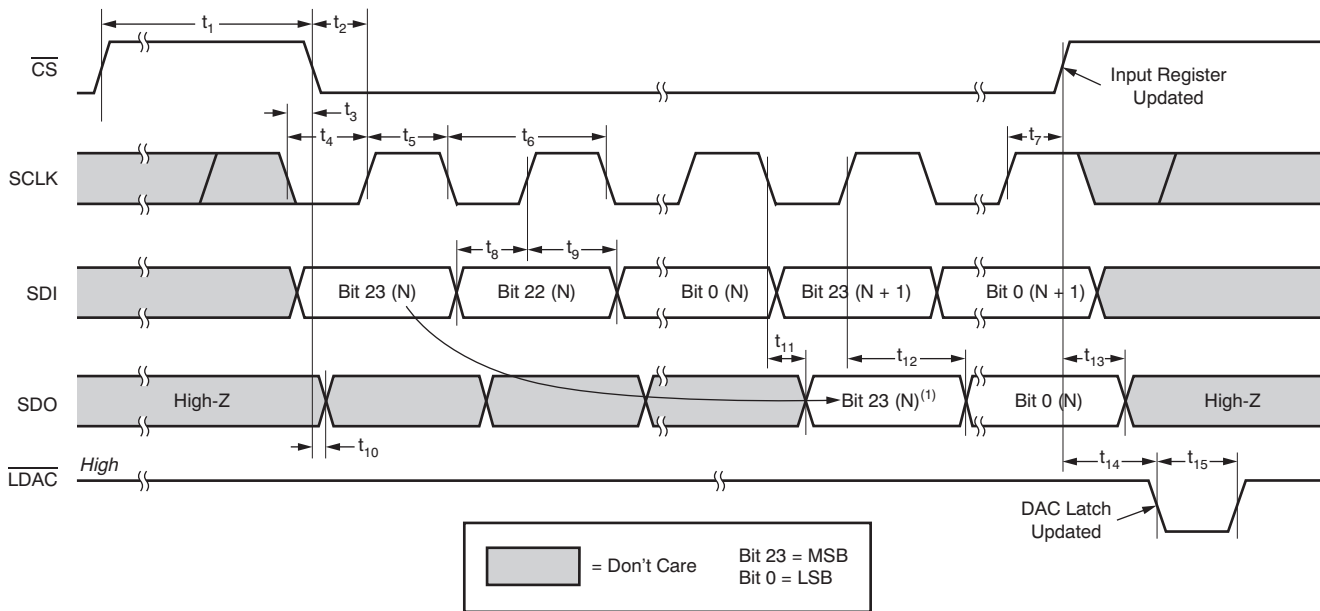


**Figure 2. Timing Diagram for Standalone Operation with SDO**

**Case 1: Daisy Chain,  $\overline{\text{LDAC}}$  tied low.**



**Case 2: Daisy Chain,  $\overline{\text{LDAC}}$  active.**



NOTE: (1) SDO data delayed from SDI by 24 clock cycles.

**Figure 3. Timing Diagram for Daisy Chain Mode, Two Cascaded Devices**

### 6.9 Typical Characteristics: $AV_{DD} = 5\text{ V}$

At  $T_A = 25^\circ\text{C}$ ,  $V_{REFH} = 5\text{ V}$ ,  $V_{REFL} = 0\text{ V}$ , and Gain = 1X Mode, unless otherwise noted.

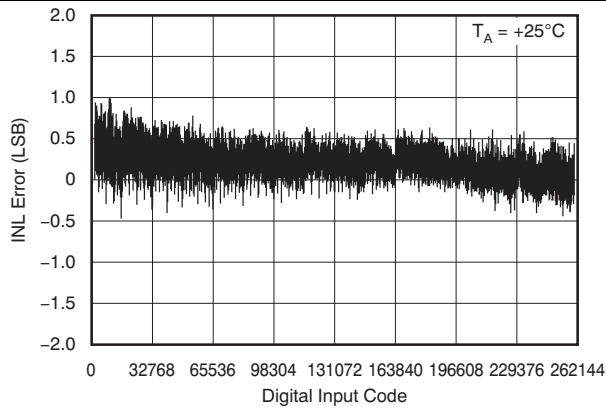


Figure 4. Linearity Error vs Digital Input Code

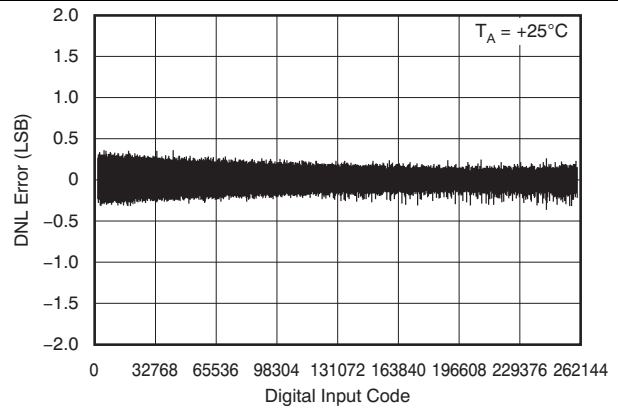


Figure 5. Differential Linearity Error vs Digital Input Code

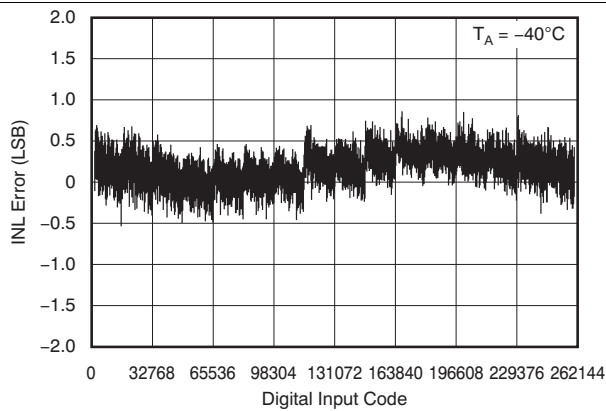


Figure 6. Linearity Error vs Digital Input Code

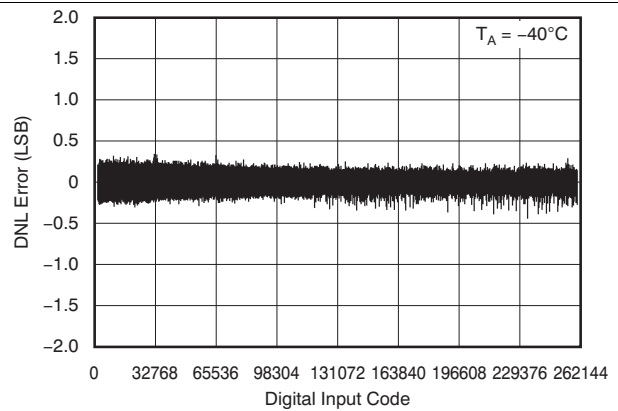


Figure 7. Differential Linearity Error vs Digital Input Code

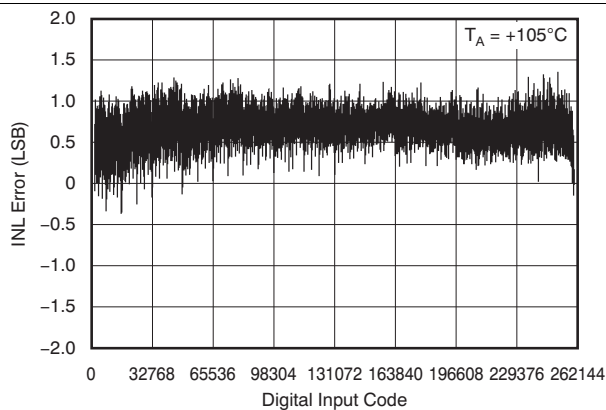


Figure 8. Linearity Error vs Digital Input Code

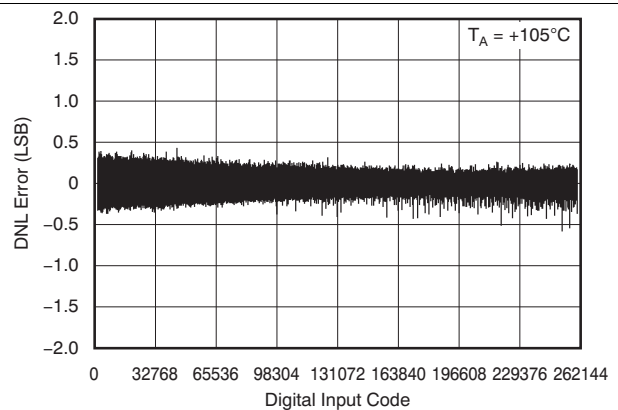
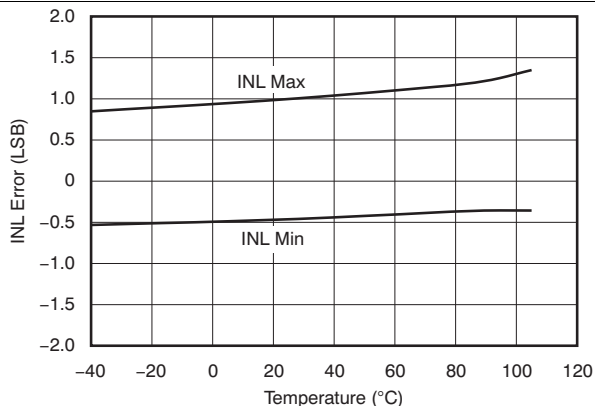


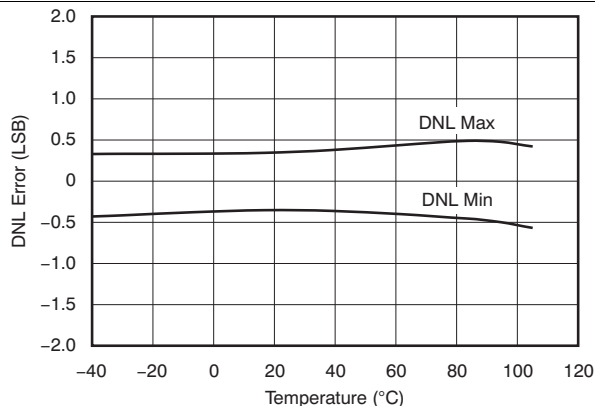
Figure 9. Differential Linearity Error vs Digital Input Code

**Typical Characteristics:  $A_{V_{DD}} = 5\text{ V}$  (continued)**

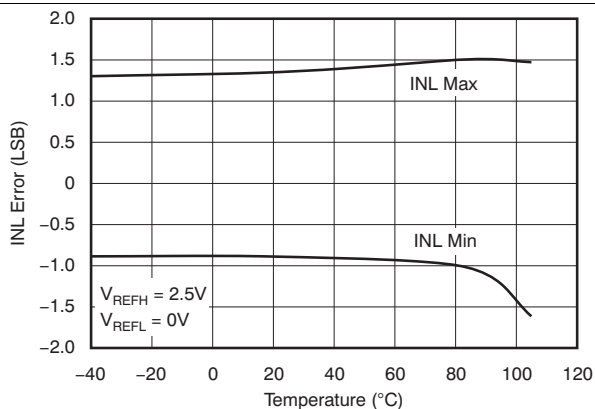
At  $T_A = 25^\circ\text{C}$ ,  $V_{REFH} = 5\text{ V}$ ,  $V_{REFL} = 0\text{ V}$ , and Gain = 1X Mode, unless otherwise noted.



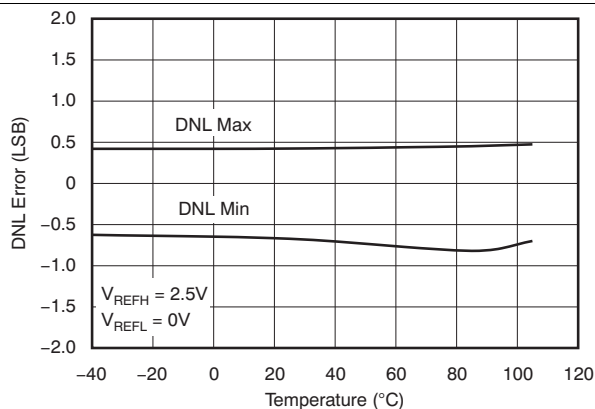
**Figure 10. Linearity Error vs Temperature**



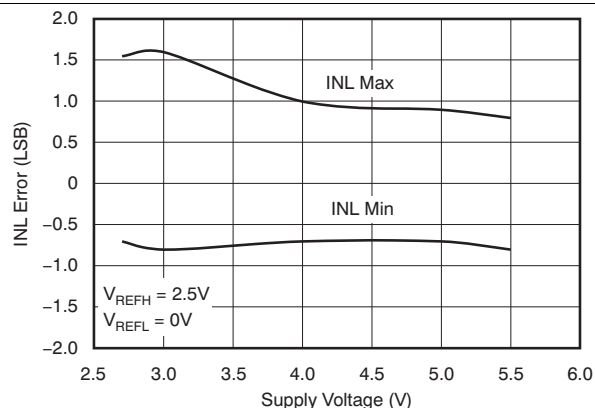
**Figure 11. Differential Linearity Error vs Temperature**



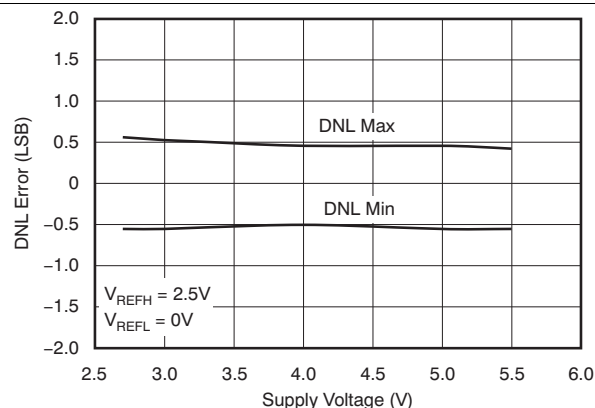
**Figure 12. Linearity Error vs Temperature (Gain = 2X Mode)**



**Figure 13. Differential Linearity Error vs Temperature (Gain = 2X Mode)**



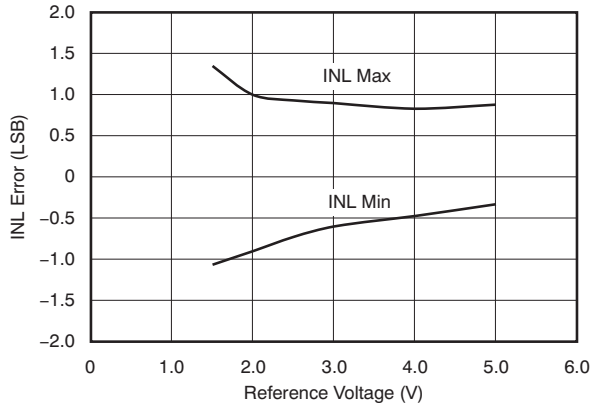
**Figure 14. Linearity Error vs Supply Voltage**



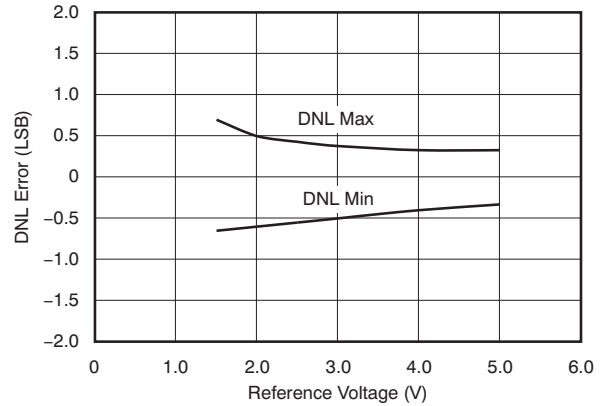
**Figure 15. Differential Linearity Error vs Supply Voltage**

**Typical Characteristics:  $V_{DD} = 5\text{ V}$  (continued)**

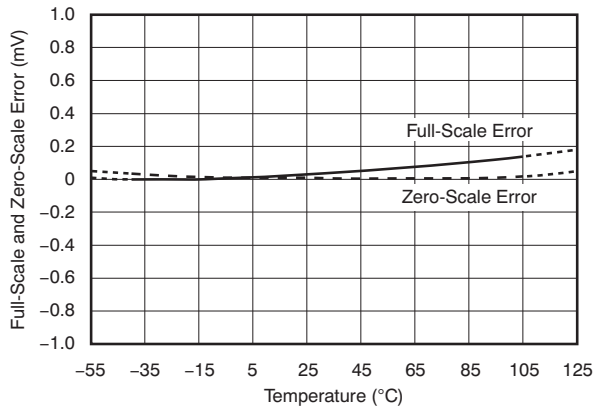
At  $T_A = 25^\circ\text{C}$ ,  $V_{REFH} = 5\text{ V}$ ,  $V_{REFL} = 0\text{ V}$ , and Gain = 1X Mode, unless otherwise noted.



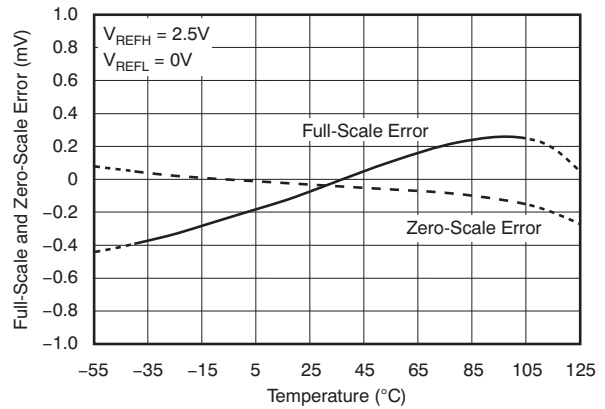
**Figure 16. Linearity Error vs Reference Voltage**



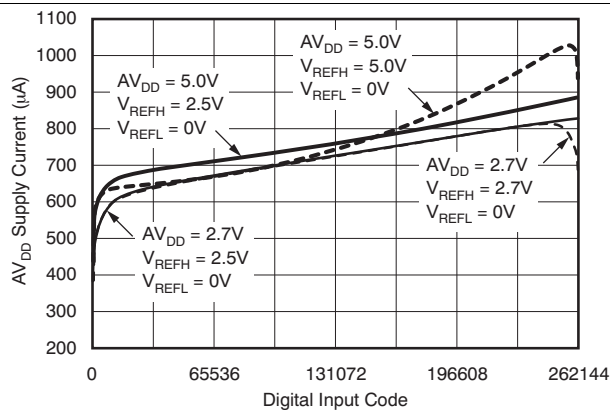
**Figure 17. Differential Linearity Error vs Reference Voltage**



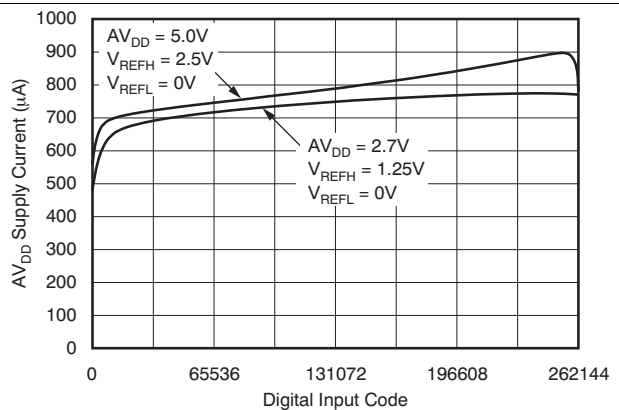
**Figure 18. Full-Scale and Zero-Scale Error vs Temperature**



**Figure 19. Full-Scale and Zero-Scale Error vs Temperature (Gain = 2X Mode)**



**Figure 20. AVDD Supply Current vs Digital Input Code**



**Figure 21. AVDD Supply Current vs Digital Input Code (Gain = 2X Mode)**

Typical Characteristics: AV<sub>DD</sub> = 5 V (continued)

At T<sub>A</sub> = 25°C, V<sub>REFH</sub> = 5 V, V<sub>REFL</sub> = 0 V, and Gain = 1X Mode, unless otherwise noted.

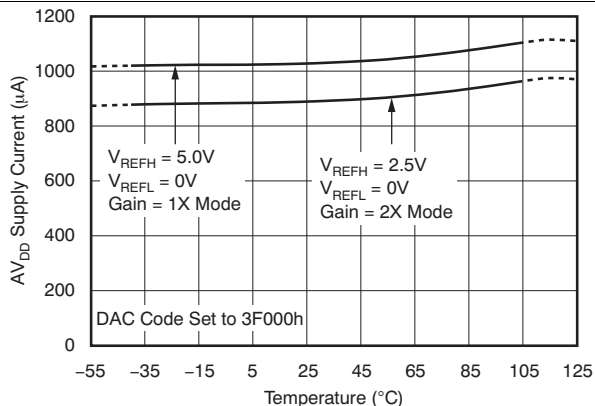


Figure 22. AVDD Supply Current vs Temperature

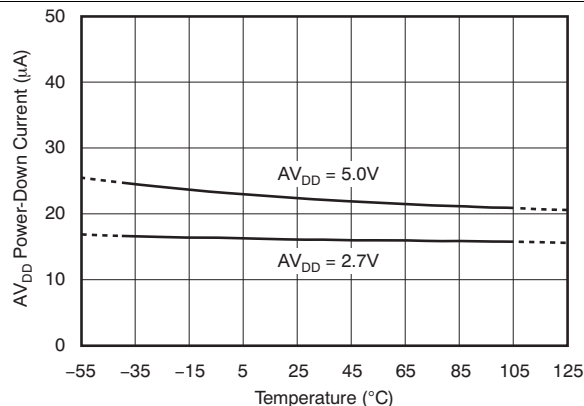


Figure 23. AVDD Power-Down Current vs Temperature

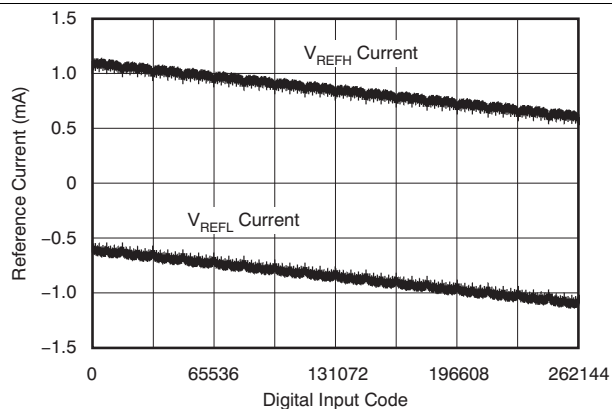


Figure 24. Reference Current vs Digital Input Code

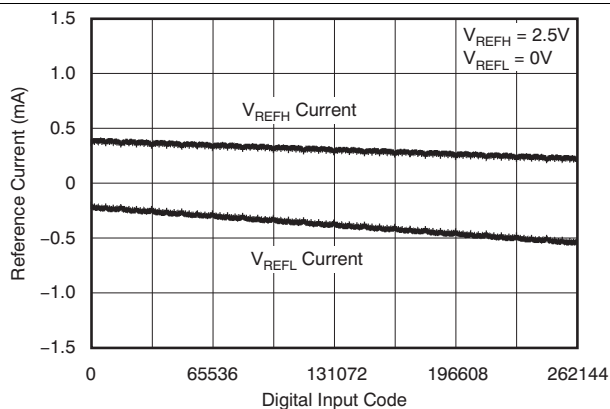


Figure 25. Reference Current vs Digital Input Code (Gain = 2X Mode)

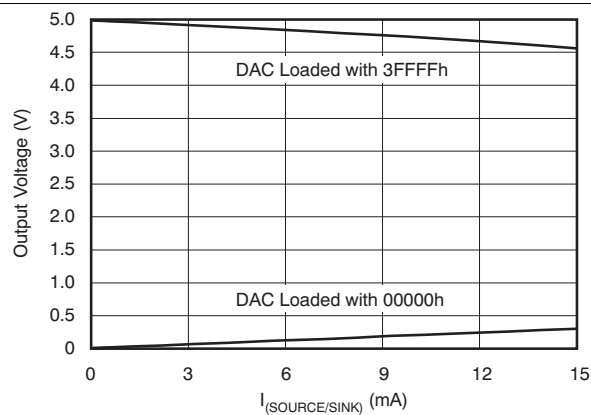


Figure 26. Output Voltage vs Drive Current Capability

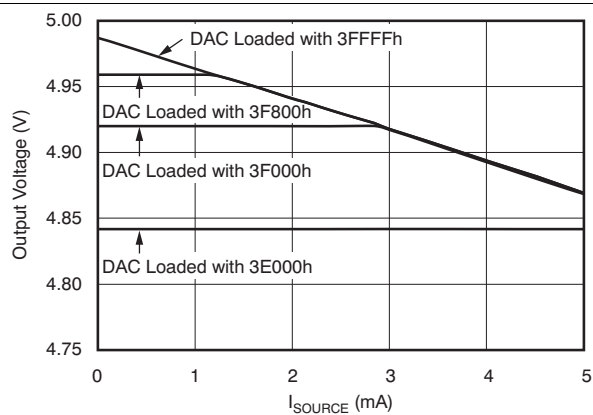
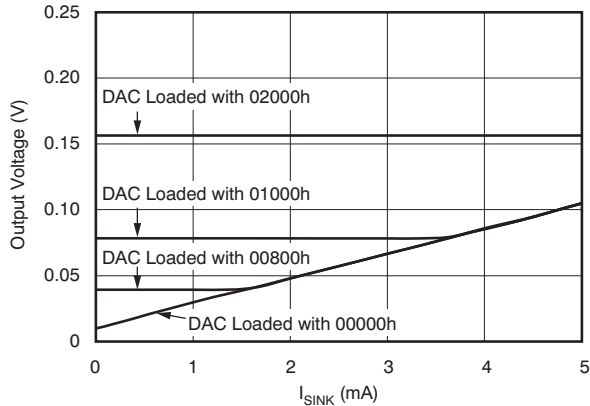


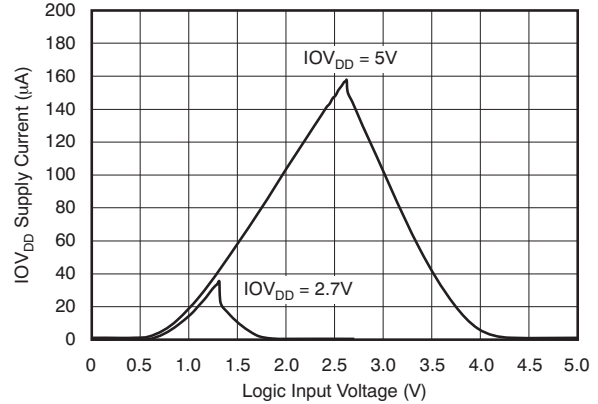
Figure 27. Output Voltage vs Drive Current Capability (Operation Near AV<sub>DD</sub> Rail)

**Typical Characteristics:  $V_{DD} = 5\text{ V}$  (continued)**

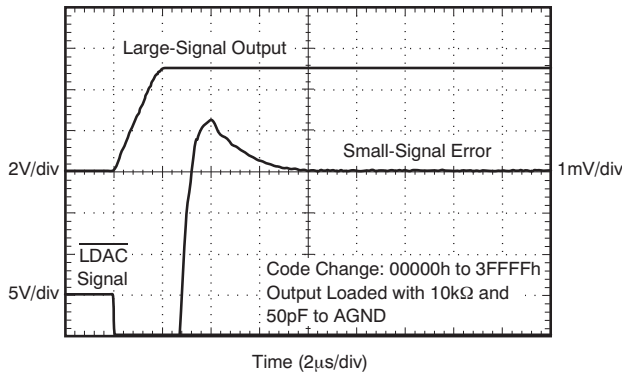
At  $T_A = 25^\circ\text{C}$ ,  $V_{REFH} = 5\text{ V}$ ,  $V_{REFL} = 0\text{ V}$ , and Gain = 1X Mode, unless otherwise noted.



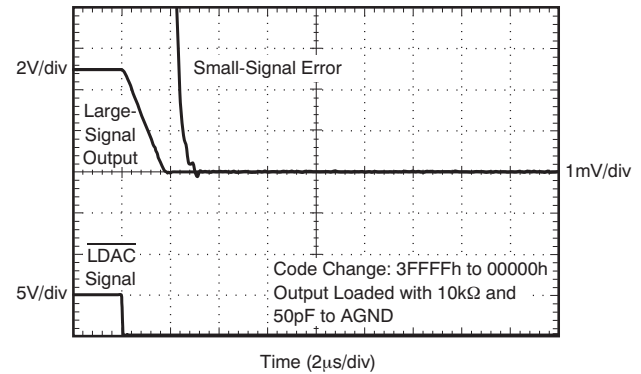
**Figure 28. Output Voltage vs Drive Current Capability (Operation Near AGND Rail)**



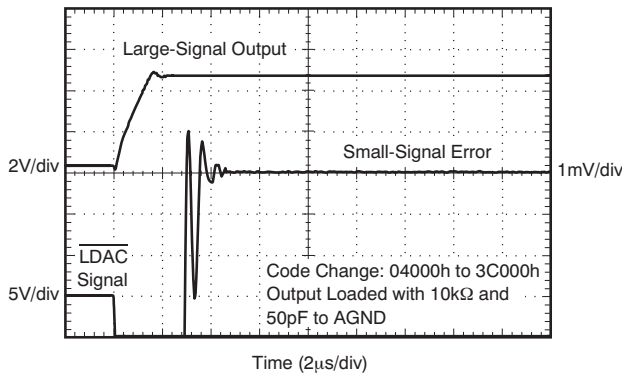
**Figure 29. IOVDD Supply Current vs Logic Input Voltage**



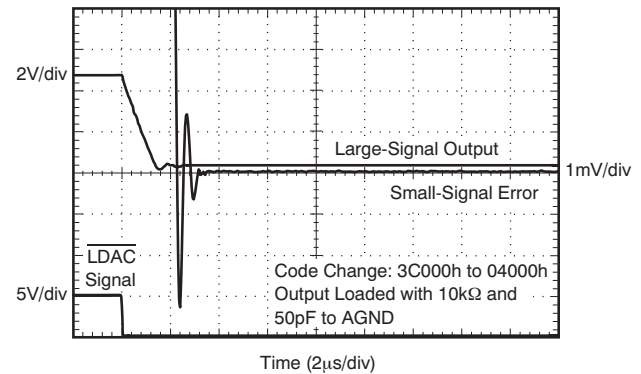
**Figure 30. Large Signal Settling Time**



**Figure 31. Large Signal Settling Time**



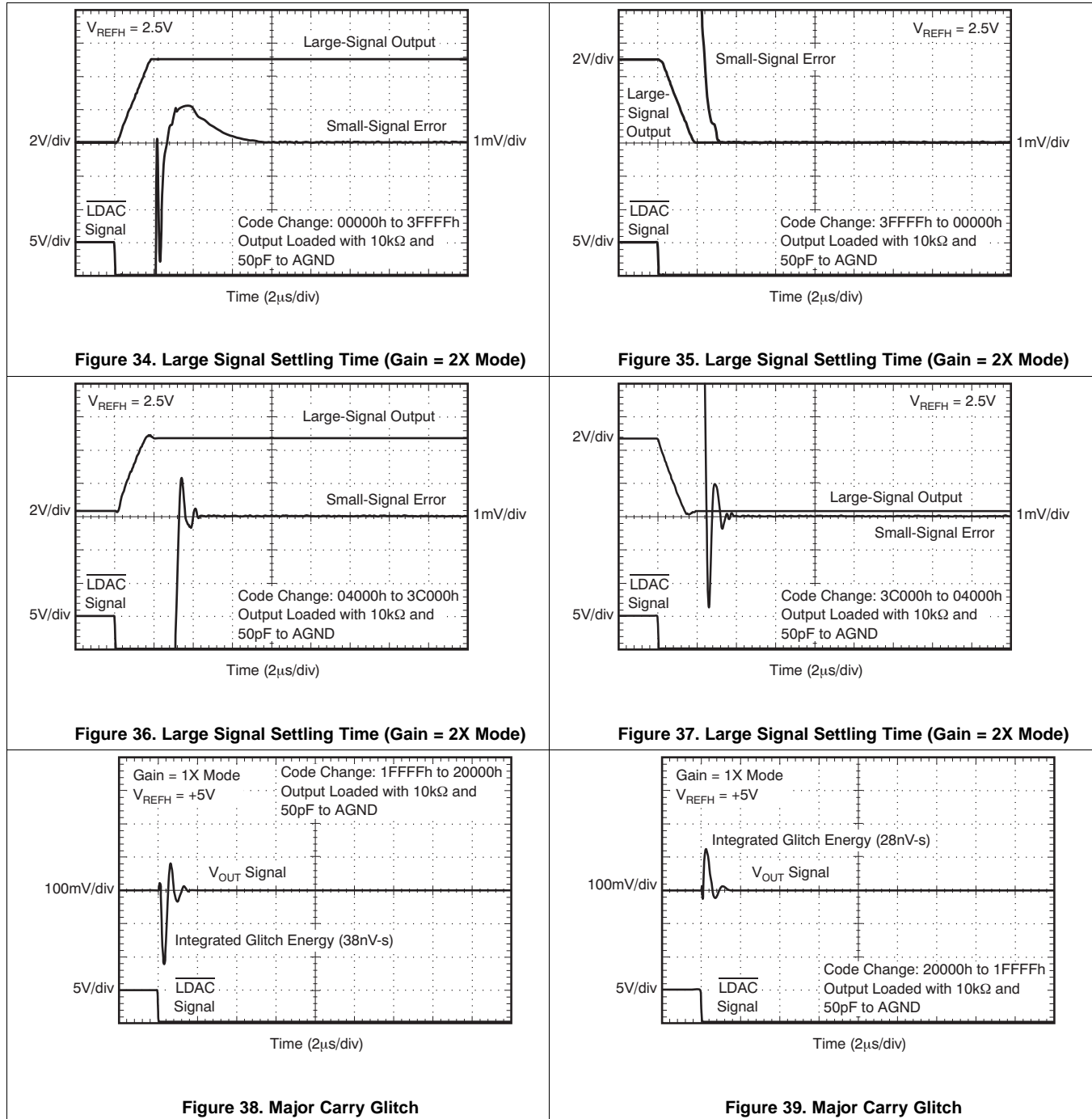
**Figure 32. Large Signal Settling Time**



**Figure 33. Large Signal Settling Time**

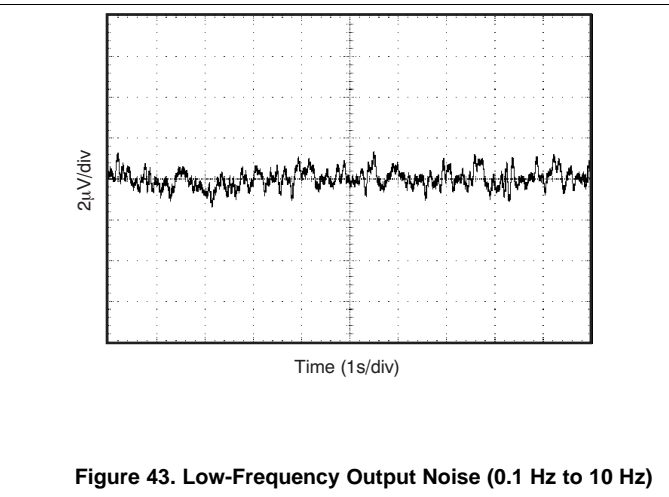
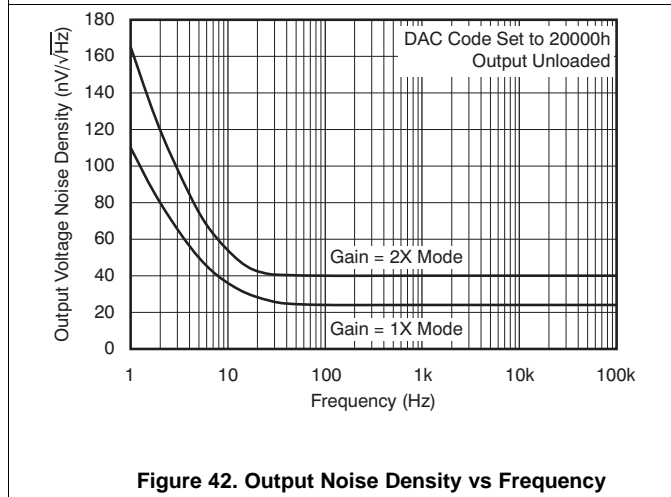
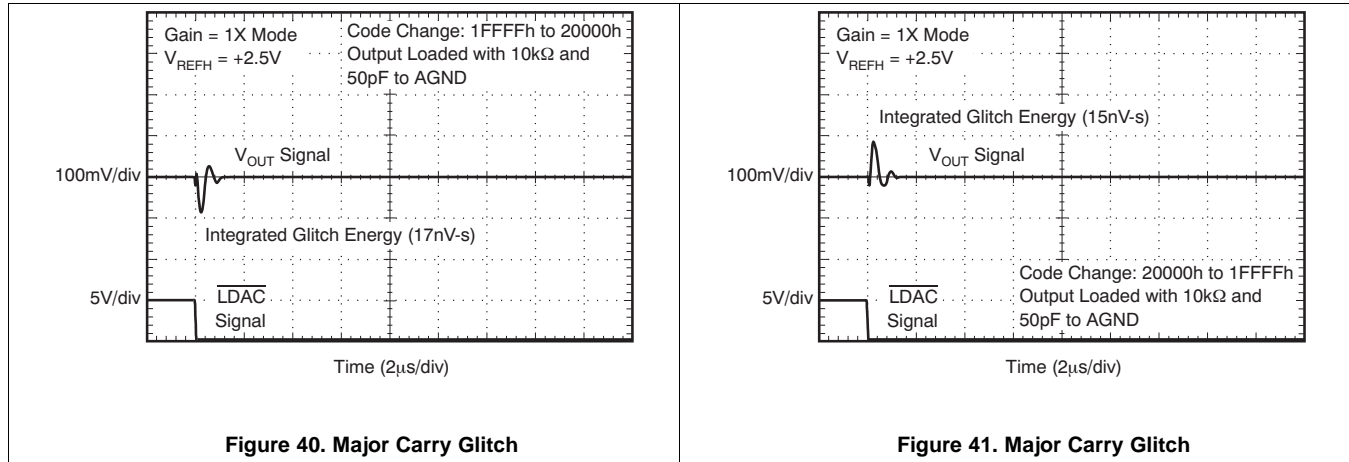
Typical Characteristics:  $V_{DD} = 5\text{ V}$  (continued)

At  $T_A = 25^\circ\text{C}$ ,  $V_{REFH} = 5\text{ V}$ ,  $V_{REFL} = 0\text{ V}$ , and Gain = 1X Mode, unless otherwise noted.



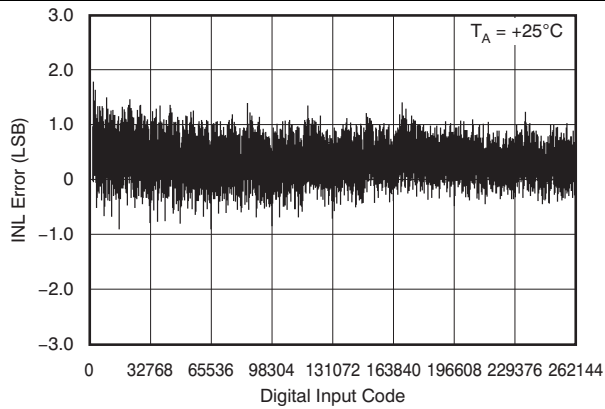
**Typical Characteristics:  $A_{V_{DD}} = 5\text{ V}$  (continued)**

At  $T_A = 25^\circ\text{C}$ ,  $V_{REFH} = 5\text{ V}$ ,  $V_{REFL} = 0\text{ V}$ , and Gain = 1X Mode, unless otherwise noted.

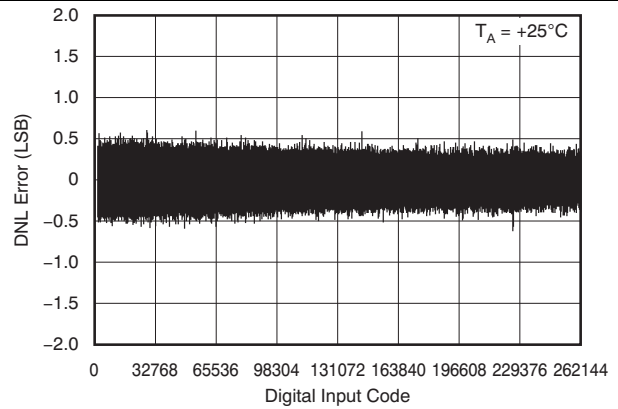


### 6.10 Typical Characteristics: $AV_{DD} = 2.7\text{ V}$

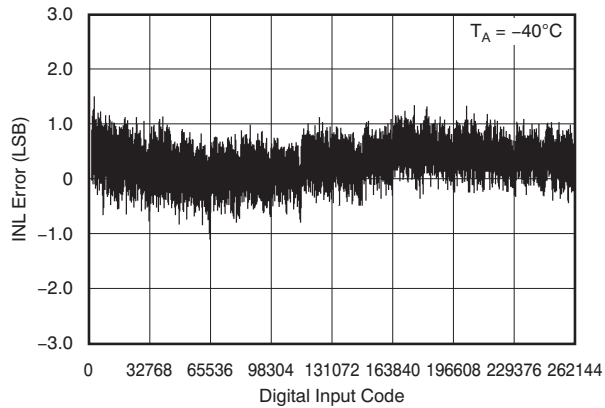
At  $T_A = 25^\circ\text{C}$ ,  $V_{REFH} = 2.5\text{ V}$ ,  $V_{REFL} = 0\text{ V}$ , and Gain = 1X Mode, unless otherwise noted.



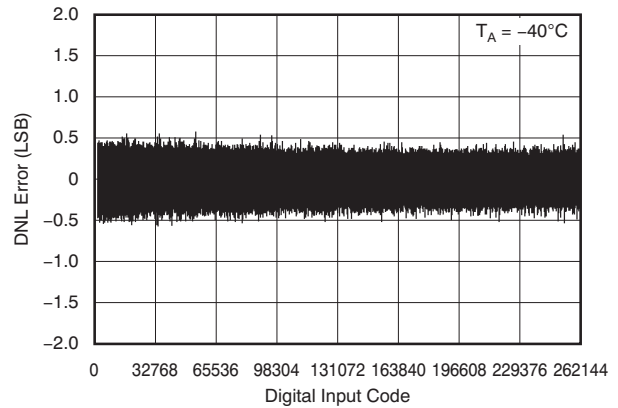
**Figure 44. Linearity Error vs Digital Input Code**



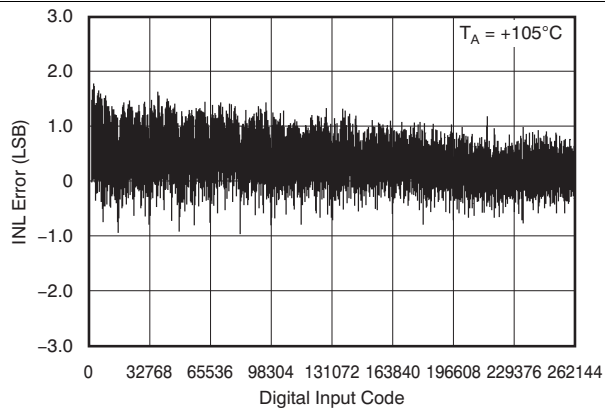
**Figure 45. Differential Linearity Error vs Digital Input Code**



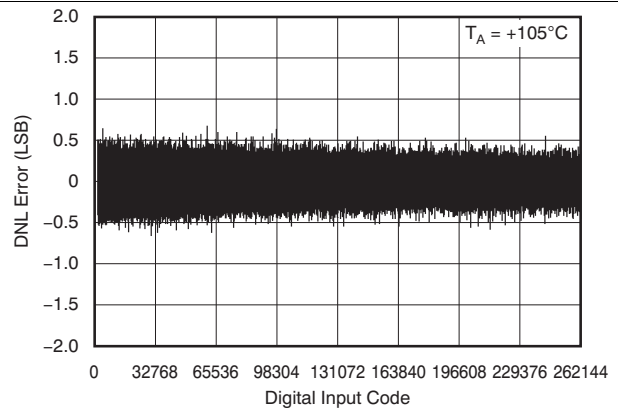
**Figure 46. Linearity Error vs Digital Input Code**



**Figure 47. Differential Linearity Error vs Digital Input Code**



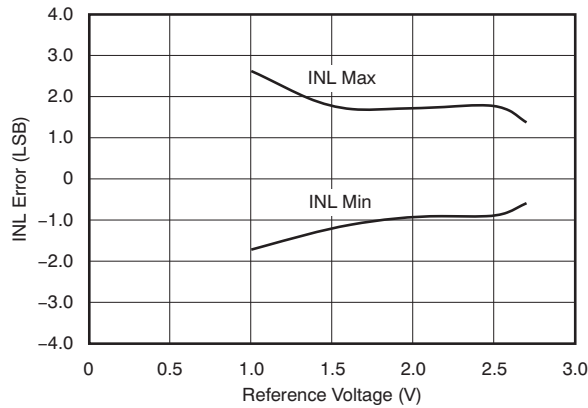
**Figure 48. Linearity Error vs Digital Input Code**



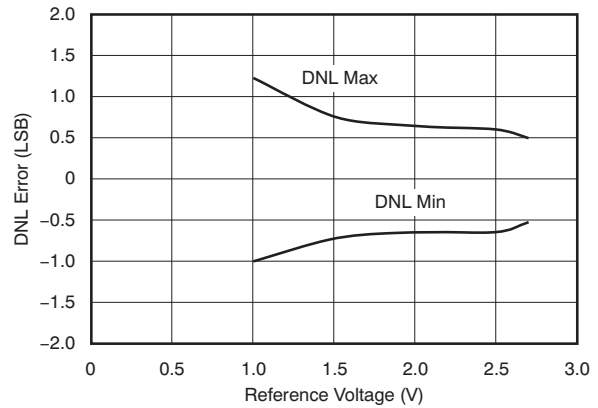
**Figure 49. Differential Linearity Error vs Digital Input Code**

**Typical Characteristics:  $V_{DD} = 2.7\text{ V}$  (continued)**

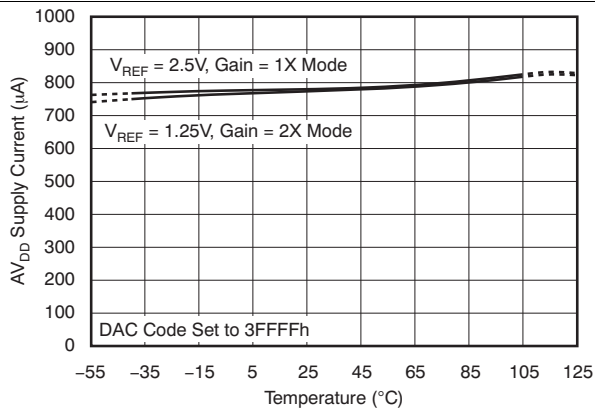
At  $T_A = 25^\circ\text{C}$ ,  $V_{REFH} = 2.5\text{ V}$ ,  $V_{REFL} = 0\text{ V}$ , and Gain = 1X Mode, unless otherwise noted.



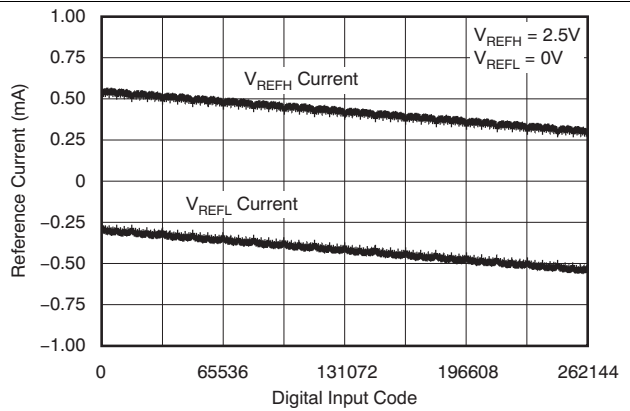
**Figure 50. Linearity Error vs Reference Voltage**



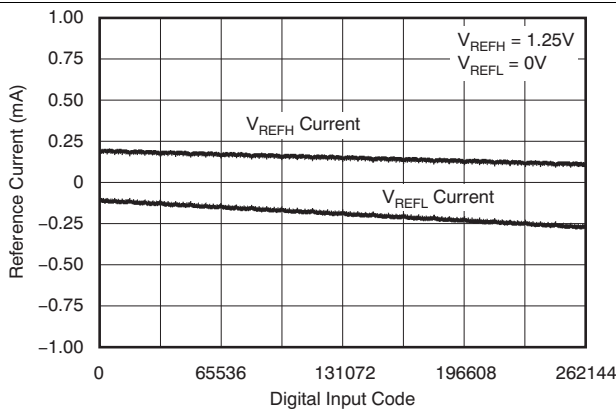
**Figure 51. Differential Linearity Error vs Reference Voltage**



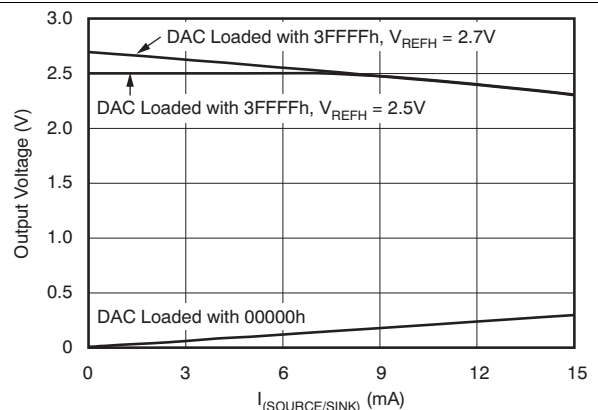
**Figure 52. AVDD Supply Current vs Temperature**



**Figure 53. Reference Current vs Digital Input Code**



**Figure 54. Reference Current vs Digital Input Code (Gain = 2X Mode)**



**Figure 55. Output Voltage vs Drive Current Capability**

Typical Characteristics:  $V_{DD} = 2.7\text{ V}$  (continued)

At  $T_A = 25^\circ\text{C}$ ,  $V_{REFH} = 2.5\text{ V}$ ,  $V_{REFL} = 0\text{ V}$ , and Gain = 1X Mode, unless otherwise noted.

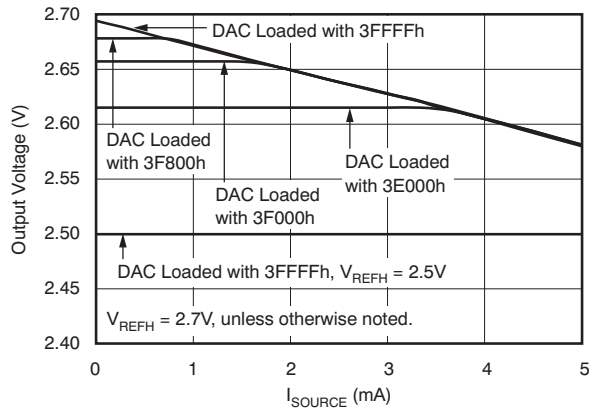


Figure 56. Output Voltage vs Drive Current Capability (Operation Near  $V_{DD}$  Rail)

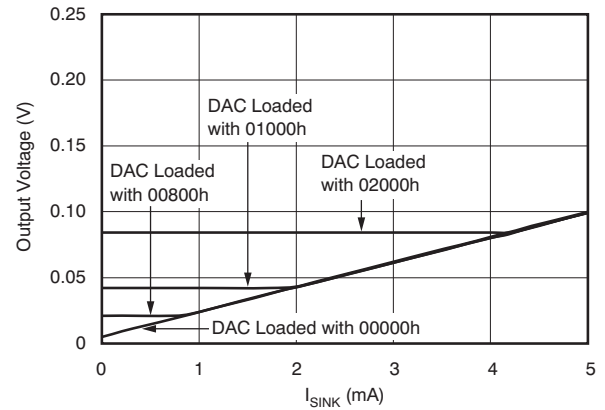


Figure 57. Output Voltage vs Drive Current Capability (Operation Near AGND Rail)

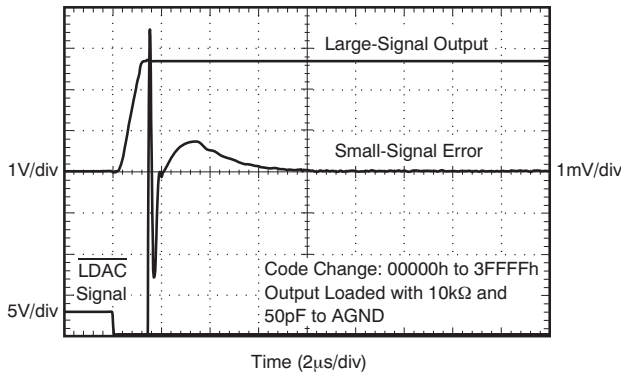


Figure 58. Large Signal Settling Time

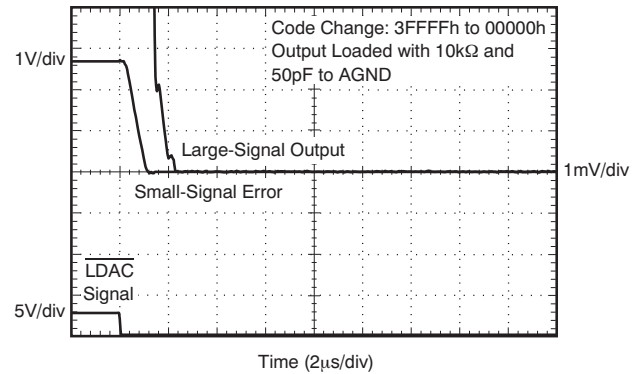


Figure 59. Large Signal Settling Time

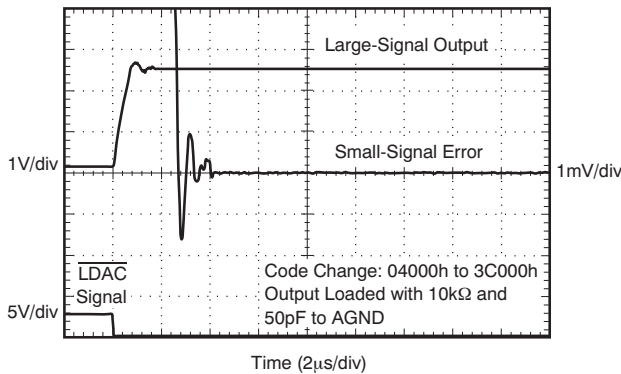


Figure 60. Large Signal Settling Time

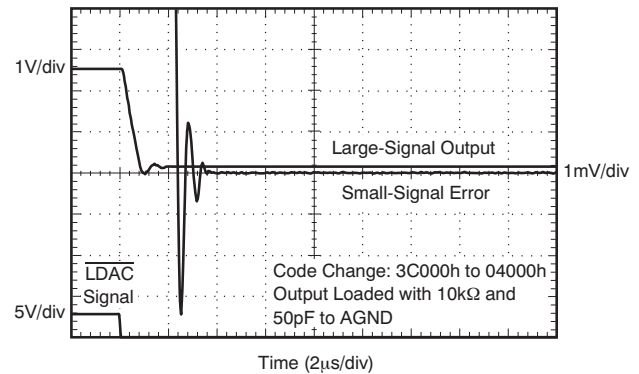
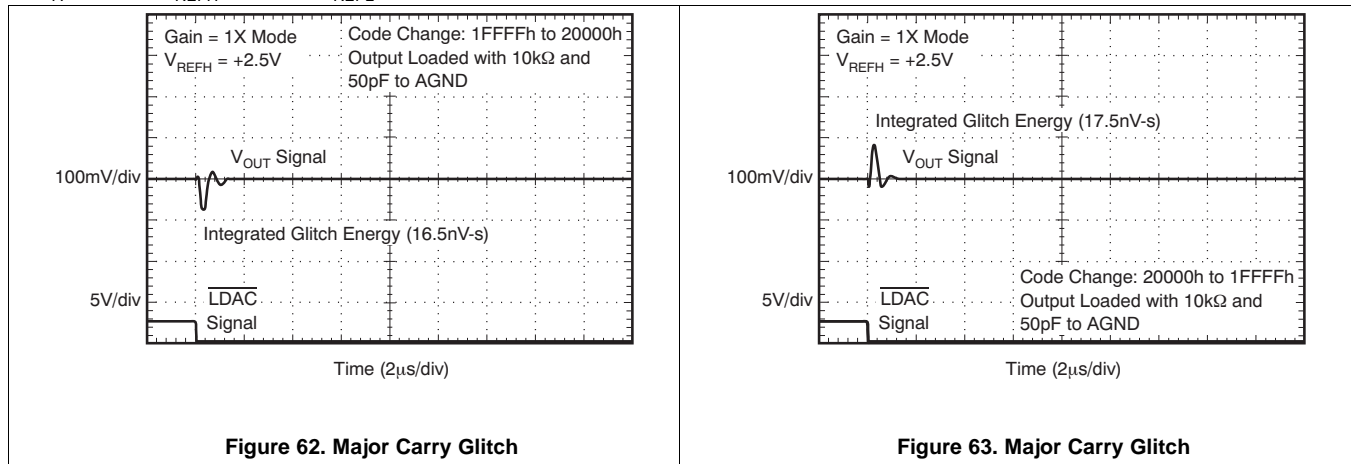


Figure 61. Large Signal Settling Time

**Typical Characteristics:  $A_{V_{DD}} = 2.7\text{ V}$  (continued)**

 At  $T_A = 25^\circ\text{C}$ ,  $V_{REFH} = 2.5\text{ V}$ ,  $V_{REFL} = 0\text{ V}$ , and Gain = 1X Mode, unless otherwise noted.


## 7 Detailed Description

### 7.1 Overview

The DAC9881 is a single-channel, 18-bit, serial-input, voltage-output digital-to-analog converter (DAC). The architecture is an R-2R ladder configuration with the four MSBs segmented, followed by an operational amplifier that serves as a buffer, as shown in Figure 64. The on-chip output buffer allows rail-to-rail output swings while providing a low output impedance to drive loads. The DAC9881 operates from a single analog power supply that ranges from 2.7V to 5.5V, and typically consumes 850µA when operating with a 5V supply. Data are written to the device in a 24-bit word format, via an SPI serial interface. To enable compatibility with 1.8V, 3V, or 5V logic families, an IOV<sub>DD</sub> supply pin is provided. This pin allows the DAC9881 input and output logic to be powered from the same logic supply used to interface signals to and from the device. Internal voltage translators are included in the DAC9881 to interface digital signals to the device core. See Figure 65 for the basic configuration of the DAC9881.

To ensure a known power-up state, the DAC9881 is designed with a power-on reset function. Upon power-up, the DAC9881 is reset to either zero-scale or midscale depending on the state of the RSTSEL pin. A hardware reset can be performed by using the RST and RSTSEL pins.

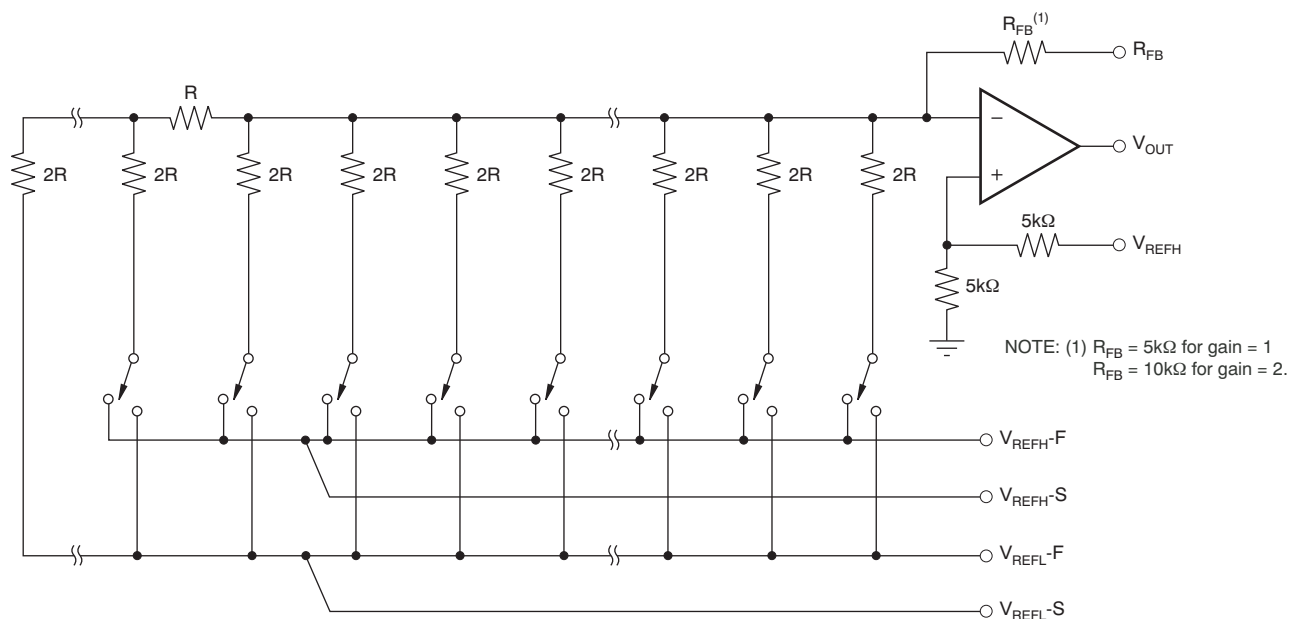


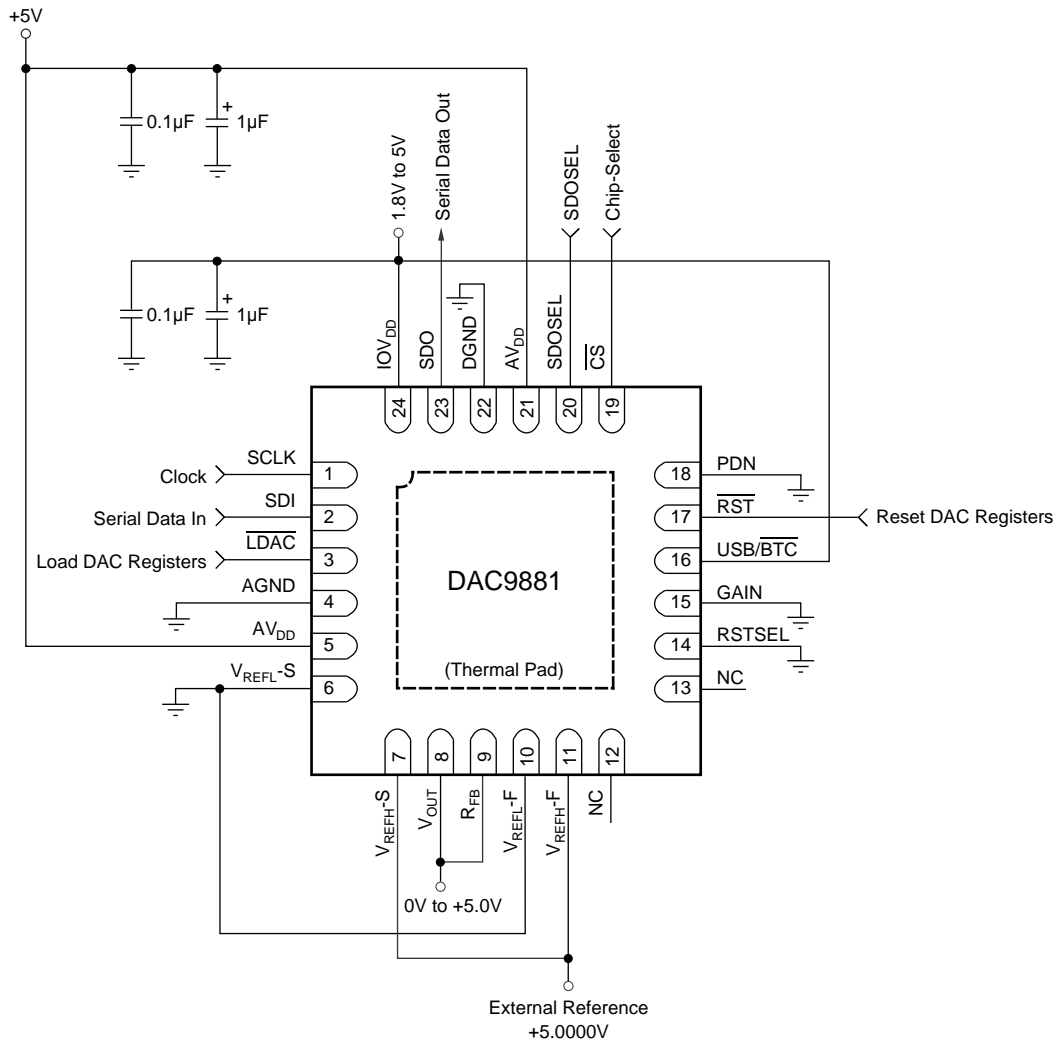
Figure 64. DAC9881 Architecture

**DAC9881**

SBAS438B –MAY 2008–REVISED SEPTEMBER 2016

www.ti.com

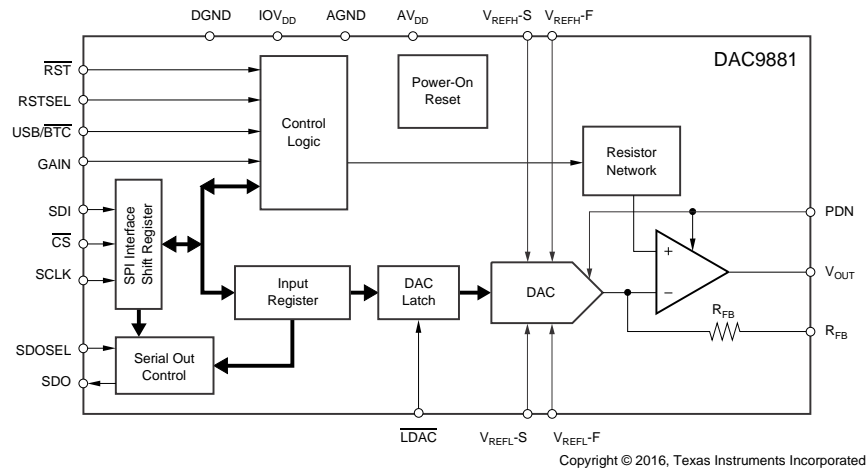
**Overview (continued)**



Copyright © 2016, Texas Instruments Incorporated

**Figure 65. Basic Configuration**

## 7.2 Functional Block Diagram



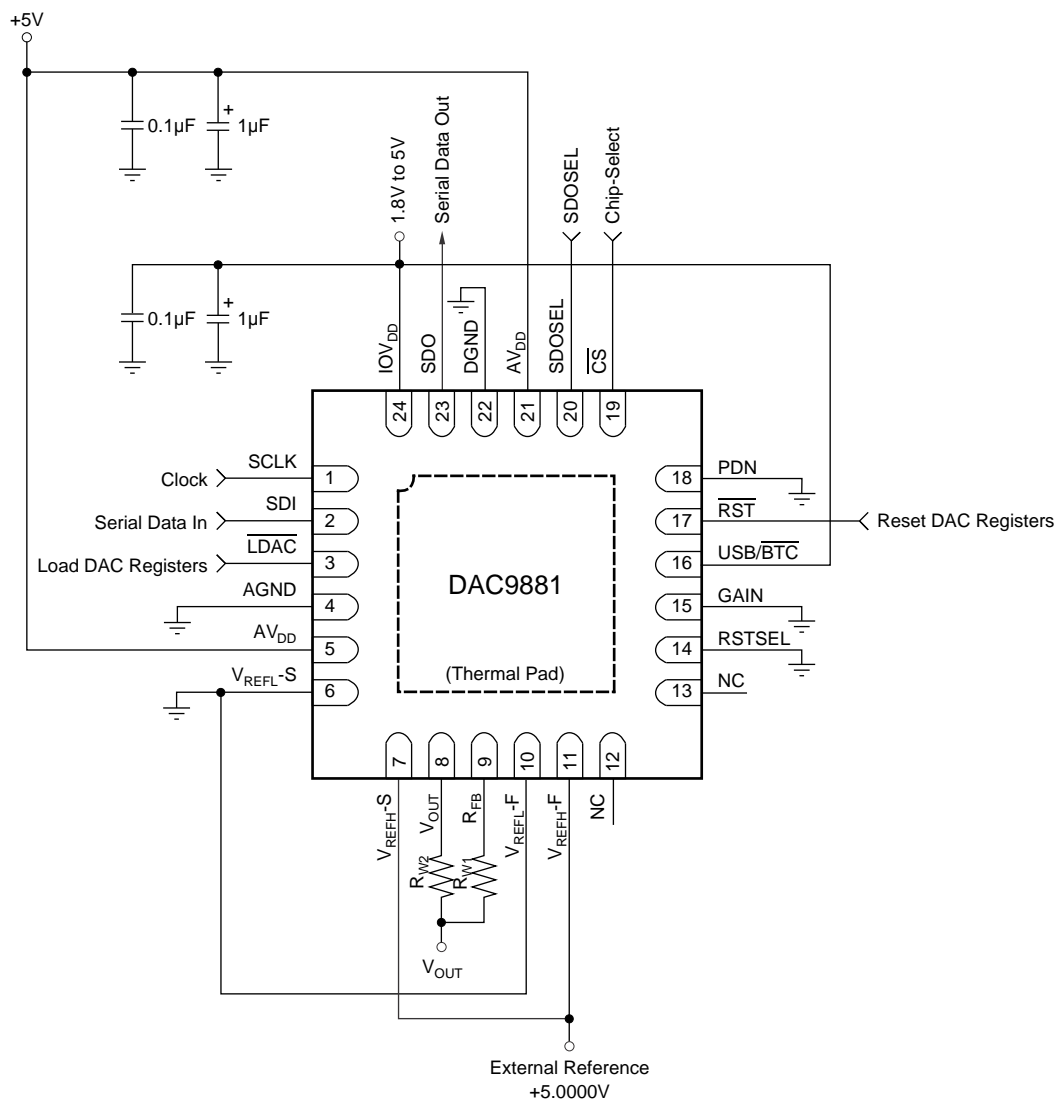
## 7.3 Feature Description

### 7.3.1 Analog Output

The DAC9881 offers a force and sense output configuration for the high open-loop gain output amplifier. This feature allows the loop around the output amplifier to be closed at the load (as shown in [Figure 66](#)), thus ensuring an accurate output voltage. The output buffer  $V_{OUT}$  and  $R_{FB}$  pins are provided so that the output op amp buffer feedback can be connected at the load. Without a driven load, the DAC9881 output typically swings to within 15 mV of the AGND and  $AV_{DD}$  supply rails. Because of the high accuracy of these DACs, system design problems such as grounding and wiring resistance become very important. A 18-bit converter with a 5-V full-scale range has an LSB value of 19  $\mu$ V. The DAC9881 has a typical feedback resistor current of 0.5 mA; thus, a series wiring resistance of only 100 m $\Omega$  ( $R_{W1}$ ) causes a voltage drop of 50  $\mu$ V. In terms of a system layout, the resistivity of a typical 1-ounce copper-clad printed circuit board (PCB) is 0.5-m $\Omega$  per square. For a 0.5-mA current, a 0.25-mm wide printed-circuit conductor 25-mm long results in a voltage drop of 25  $\mu$ V.

#### NOTE

the wiring resistance of  $R_{W2}$  is not critical as long as the feedback resistor ( $R_{FB}$ ) is connected at the driven load.

**Feature Description (continued)**


Copyright © 2016, Texas Instruments Incorporated

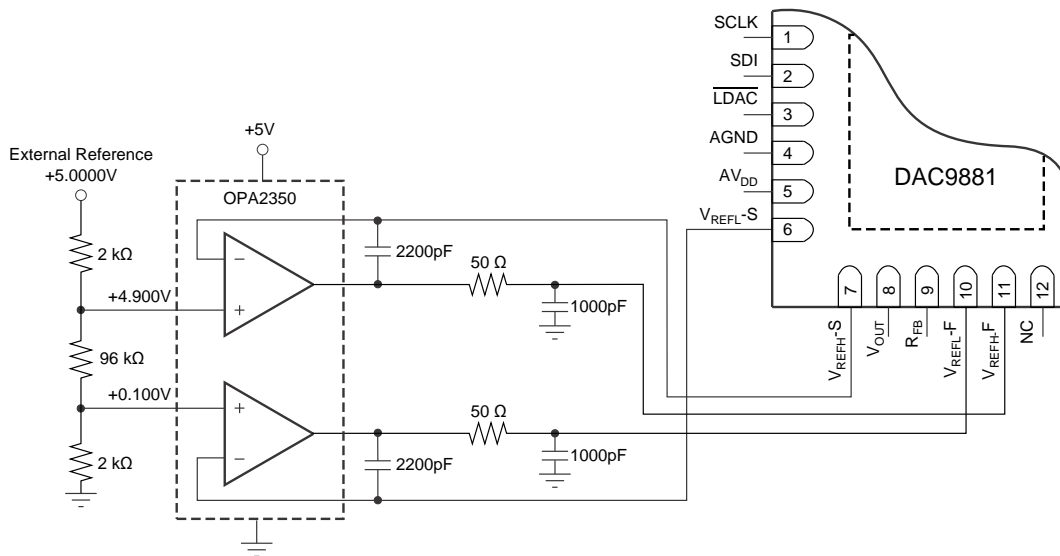
**Figure 66. Analog Output Closed-Loop Configuration**  
 ( $R_{W1}$  and  $R_{W2}$  Represent Wiring Resistance)

**7.3.2 Reference Inputs**

The reference high input,  $V_{REFH}$ , can be set to any voltage in the range of 1.25 V to  $AV_{DD}$ . The reference low input,  $V_{REFL}$ , can be set to any voltage in the range of  $-0.2$  V to  $+0.2$  V (to provide a small offset to the output of the DAC9881, if desired). The current into  $V_{REFH}$  and out of  $V_{REFL}$  depends on the DAC code, and can vary from approximately 0.5 mA to 1 mA in the gain = 1X mode of operation. The reference high and low inputs appear as variable loads to the external reference circuit. If the external references can source or sink the required current, and if low impedance connections are made to the  $V_{REFH}$  and  $V_{REFL}$  pins, external reference buffers are not required. Figure 65 shows a simple configuration of the DAC9881 using external references without force and sense reference buffers.

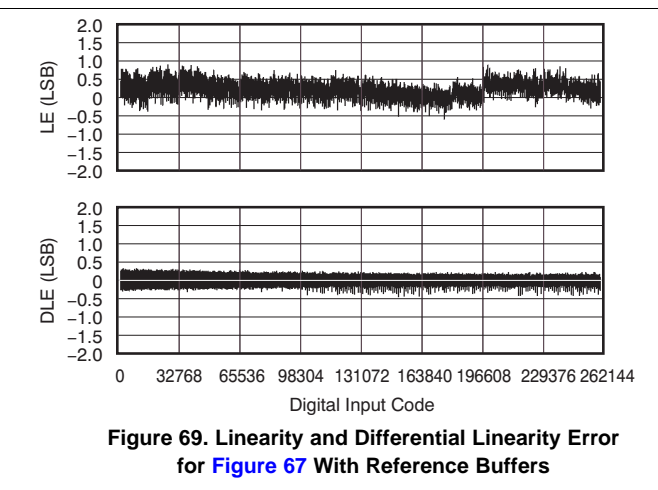
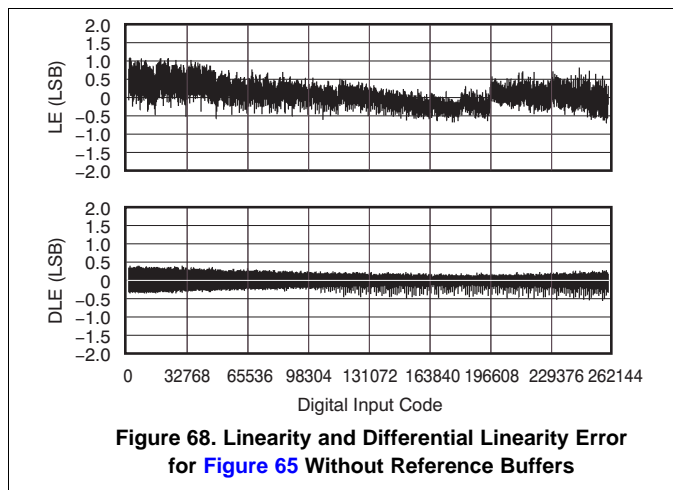
### Feature Description (continued)

Kelvin sense connections for the reference high and low are included on the DAC9881. When properly used with external reference buffer op amps, these reference Kelvin sense pins ensure that the driven reference high and low voltages remain stable versus varying reference load currents. Figure 67 shows an example of a reference force and sense configuration of the DAC9881 operating from a single analog reference voltage. Both the  $V_{REFL}$  and  $V_{REFH}$  reference voltages are set to levels of 100mV from the DAC9881 supply rails, and are derived from a +5-V external reference. Figure 68 illustrates the effect of not using the reference force and sense buffers to drive the DAC9881  $V_{REFL}$  and  $V_{REFH}$  pins. Figure 69 shows the improvement when using the reference buffers. A slight degradation in INL and DNL performance is seen without the use of the force and sense buffer configuration.



Copyright © 2016, Texas Instruments Incorporated

Figure 67. Buffered References ( $V_{REFH} = +4.900V$  and  $V_{REFL} = 100mV$ ).



## Feature Description (continued)

### 7.3.3 Output Range

The maximum output range of the DAC9881 is  $V_{REFL}$  to  $(V_{REFH} - V_{REFL}) \times G$ , where  $G$  is the output buffer gain set by the GAIN pin. When the GAIN pin is connected to DGND, the output buffer gain = 1. When the GAIN pin is connected to IOV<sub>DD</sub>, the output buffer gain = 2. The output range must not be greater than AV<sub>DD</sub>; otherwise, output saturation occurs. The DAC9881 output transfer function is given in [Equation 1](#):

$$V_{OUT} = \frac{V_{REFH} - V_{REFL}}{262144} \times \text{CODE} \times \text{Buffer Gain} + V_{REFL}$$

where

- CODE = 0 to 262143. This is the digital code loaded to the DAC
  - Buffer Gain = 1 or 2 (set by the GAIN pin)
  - V<sub>REFH</sub> = reference high voltage applied to the device
  - V<sub>REFL</sub> = reference low voltage applied to the device
- (1)

### 7.3.4 Input Data Format

The USB/ $\overline{\text{BTC}}$  pin defines the input data format. When this pin is connected to IOV<sub>DD</sub>, the input data format is straight binary, as shown in [Table 1](#). When this pin is connected to DGND, the input data format is twos complement, as shown in [Table 2](#).

**Table 1. Output vs Straight Binary Code**

USB CODE	5V RANGE	DESCRIPTION
3FFFFh	+4.99998	+Full-Scale – 1LSB
30000h	+3.75000	3/4-Scale
20000h	+2.50000	Midscale
10000h	+1.25000	1/4-Scale
00000h	0.00000	Zero-Scale

**Table 2. Output vs Twos Complement Code**

$\overline{\text{BTC}}$ CODE	5V RANGE	DESCRIPTION
1FFFFh	+4.99998	+Full-Scale – 1LSB
10000h	+3.75000	3/4-Scale
00000h	+2.50000	Midscale
3FFFFh	+2.49998	Midscale – 1LSB
30000h	+1.25000	1/4-Scale
20000h	0.00000	Zero-Scale

### 7.3.5 Hardware Reset

When the  $\overline{\text{RST}}$  pin is low, the device is in hardware reset, and the input register and DAC latch are set to the value defined by the RSTSEL pin. After  $\overline{\text{RST}}$  goes high, the device is in normal operating mode, and the input register and DAC latch maintain the reset value until new data are written.

### 7.3.6 Power-On Reset

The DAC9881 has a power-on reset feature. After power-on, the value of the input register, the DAC latch, and the output from the V<sub>OUT</sub> pin are set to the value defined by the RSTSEL pin.

#### 7.3.6.1 Program Reset Value

After a power-on reset or a hardware reset, the output voltage from the V<sub>OUT</sub> pin and the values of the input register and DAC latch are determined by the status of the RSTSEL pin and the input data format, as shown in [Table 3](#).

**Table 3. Reset Value**

RSTSEL PIN	USB/BTC PIN	INPUT FORMAT	V <sub>OUT</sub>	VALUE OF INPUT REGISTER AND DAC LATCH
DGND	IOV <sub>DD</sub>	Straight Binary	0	00000h
IOV <sub>DD</sub>	IOV <sub>DD</sub>	Straight Binary	Midscale	20000h
DGND	DGND	Twos Complement	Midscale	00000h
IOV <sub>DD</sub>	DGND	Twos Complement	0	20000h

### 7.3.7 Power Down

The DAC9881 has a hardware power-down feature. When the PDN pin is high, the device is in power-down mode. When the device is in power-down, the V<sub>OUT</sub> pin is connected to ground through an internal 10kΩ resistor, but the contents of the input register and the DAC latch do not change and SPI communication remains active. When the PDN pin returns low, the device returns to normal operation.

### 7.3.8 Double-Buffered Interface

The DAC9881 has a double-buffered interface consisting of two register banks: the input register and the DAC latch. The input register is connected directly to the input shift register and the digital code is transferred to the input register upon completion of a valid write sequence. The DAC latch contains the digital code used by the resistor R-2R ladder. The contents of the DAC latch defines the output from the DAC.

Access to the DAC latch is controlled by the  $\overline{\text{LDAC}}$  pin. When  $\overline{\text{LDAC}}$  is high, the DAC latch is latched and the input register can change state without affecting the contents of the DAC latch. When  $\overline{\text{LDAC}}$  is low, however, the DAC latch becomes transparent and the contents of the input register is transferred to the DAC register.

#### 7.3.8.1 Load DAC Pin ( $\overline{\text{LDAC}}$ )

$\overline{\text{LDAC}}$  transfers data from the input register to the DAC latch (and, therefore, updates the DAC output). The contents of the DAC latch (and the output from DAC) can be changed in two ways, depending on the status of  $\overline{\text{LDAC}}$ .

##### 7.3.8.1.1 Synchronous Mode

When  $\overline{\text{LDAC}}$  is tied low, the DAC latch updates as soon as new data are transferred into the input register after the rising edge of  $\overline{\text{CS}}$ .

##### 7.3.8.1.2 Asynchronous Mode

When  $\overline{\text{LDAC}}$  is high, the DAC latch is latched. The DAC latch (and DAC output) is not updated at the same time that the input register is written to. When  $\overline{\text{LDAC}}$  goes low, the DAC latch updates with the contents of the input register.

### 7.3.9 1.8-V to 5-V Logic Interface

All digital input and output pins are compatible with any logic supply voltage between 1.8 V and 5 V. Connect the interface logic supply voltage to the IOV<sub>DD</sub> pin. Although timing is specified down to 2.7 V (see the *timing diagrams*), IOV<sub>DD</sub> can operate as low as 1.8 V, but with degraded timing and temperature performance. For the lowest power consumption, logic V<sub>IH</sub> levels should be as close as possible to IOV<sub>DD</sub>, and logic V<sub>IL</sub> levels should be as close as possible to GND.

### 7.3.10 Power-Supply Sequence

For the device to work properly, IOVDD must not come up before AV<sub>DD</sub>, and the reference voltage must come up after the AV<sub>DD</sub> supply. Additionally, because the DAC input shift register is not reset during a power-on reset or hardware reset, the  $\overline{\text{CS}}$  pin must not be unintentionally asserted during power-up of the device. To avoid improper power-up, it is recommended that the  $\overline{\text{CS}}$  and  $\overline{\text{LDAC}}$  pins be connected to IOV<sub>DD</sub> through pull-up resistors. To ensure that the electrostatic discharge (ESD) protection circuitry of this device is not activated, all other digital pins must be held at ground potential until IOV<sub>DD</sub> is applied.

## 7.4 Device Functional Modes

### 7.4.1 Serial Interface

The DAC9881 is controlled by a versatile three-wire serial interface that operates at clock rates of up to 50 MHz and is compatible with SPI, QSPI™, MICROWIRE, and DSP interface standards.

#### 7.4.1.1 Input Shift Register

Data are loaded into the device as a 24-bit word under the control of the serial clock input, SCLK. The timing diagrams for this operation are shown in *timing diagrams* section.

The  $\overline{CS}$  input is a level-triggered input that acts as a frame synchronization signal and chip enable. Data can be transferred into the device only while  $\overline{CS}$  is low. When  $\overline{CS}$  is high, the SCLK and SDI signals are blocked out, and SDO is in high-Z status. To start the serial data transfer,  $\overline{CS}$  should be taken low, observing the minimum delay from  $\overline{CS}$  falling edge to SCLK rising edge,  $t_2$ . After  $\overline{CS}$  goes low, serial input data from SDI are clocked into the device input shift register on the rising edges of SCLK for 24 or more clock pulses. If a frame contains less than 24 bits of data, the frame is invalid. Invalid input data are not written into the input register and DAC, although the input register and DAC will continue to hold data from the preceding valid data cycle. If more than 24 bits of data are transmitted in one frame, the last 24 bits are written into the shift register and DAC.  $\overline{CS}$  may be taken high after the rising edge of the 24th SCLK pulse, observing the minimum SCLK rising edge to  $\overline{CS}$  rising edge time,  $t_7$ . The contents of the shift register are transferred into the input register on the rising edge of  $\overline{CS}$ . When data have been transferred into the input register of the DAC, the corresponding DAC register and DAC output can be updated by taking the LDAC pin low. Table 4 shows the input shift register data word format. D17 is the MSB of the 18-bit DAC data.

**Table 4. Input Shift Register Data Word Format**

BIT	B23	B22	B21	B20	B19	B18	B17 (MSB)	B16	B15	B14	B13	B12	B11	B10	B9	B8	B7	B6	B5	B4	B3	B2	B1	B0 (LSB)
DATA	X <sup>(1)</sup>	X	X	X	X	X	D17	D16	D15	D14	D13	D12	D11	D10	D9	D8	D7	D6	D5	D4	D3	D2	D1	D0

(1) X = don't care.

##### 7.4.1.1.1 Stand-Alone Mode

When the SDOSEL pin is tied to IOV<sub>DD</sub>, the interface is in Stand-Alone mode. This mode provides serial readback for diagnostic purposes. The new input data (24 bits) are clocked into the device shift register and the existing data in the input register (24 bits) are shifted out from the SDO pin. If more than 24 SCLKs are clocked when  $\overline{CS}$  is low, the contents of the input register are shifted out from the SDO pin, followed by zeroes; the last 24 bits of input data remain in the shift register. If less than 24 SCLKs are clocked while  $\overline{CS}$  is low, the data from the SDO pin are part of the data in the input register and must be ignored. Refer to Figure 2 for further details.

##### 7.4.1.1.2 Daisy-Chain Mode

When the SDOSEL pin is tied to GND, the interface is in Daisy-Chain mode. For systems that contain several DACs, the SDO pin may be used to daisy-chain several devices together.

In Daisy-Chain mode, SCLK is continuously applied to the input shift register while  $\overline{CS}$  is low. If more than 24 clock pulses are applied, the data ripple out of the shift register and appear on the SDO line. These data are clocked out on the falling edge of SCLK and are valid on the rising edge. By connecting this line to the SDI input on the next DAC in the chain, a multi-DAC interface is constructed. 24 clock pulses are required for each DAC in the chain. Therefore, the total number of clock cycles must be equal to  $(24 \times N)$ , where  $N$  is the total number of devices in the chain. When the serial transfer to all devices is complete,  $\overline{CS}$  should be taken high. This action prevents any further data from being clocked into the input shift register. The contents in the shift registers are transferred into the relevant input registers on the rising edge of the  $\overline{CS}$  signal.

A continuous SCLK source may be used if  $\overline{CS}$  can be held low for the correct number of clock cycles. Alternatively, a burst clock containing the exact number of clock cycles can be used and  $\overline{CS}$  can be taken high some time later. When the transfer to all input registers is complete, a common LDAC signal updates all DAC registers, and all analog outputs update simultaneously.

## 8 Application and Implementation

### NOTE

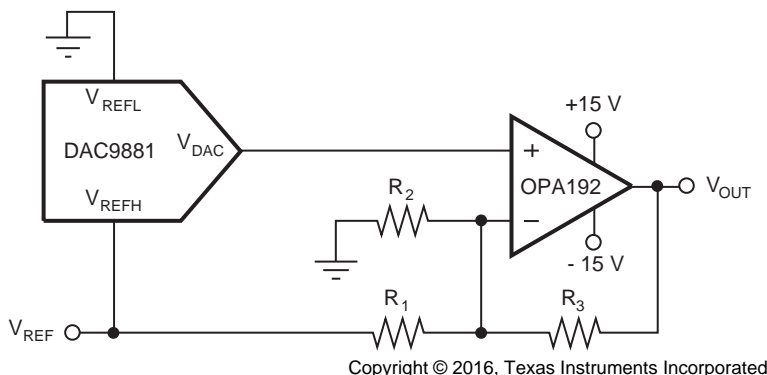
Information in the following applications sections is not part of the TI component specification, and TI does not warrant its accuracy or completeness. TI's customers are responsible for determining suitability of components for their purposes. Customers should validate and test their design implementation to confirm system functionality.

### 8.1 Application Information

The excellent linearity as well as low-noise and fast settling time makes the DAC9881 a strong performer in applications such as automatic test equipment, precision instrumentation and data acquisition systems. Additionally, the energy saving feature of the device, through the PDN pin, significantly reduces power dissipation -- this mode reduces current consumption, as low as 25  $\mu$ A with a 5-V supply.

#### 8.1.1 Bipolar Operation Using the DAC9881

The DAC9881 is designed for single-supply operation; however, a bipolar output is also possible using the circuit shown in [Figure 70](#). This circuit gives a bipolar output voltage of  $V_{OUT}$ . When  $GAIN = 1$ ,  $V_{OUT}$  can be calculated using [Equation 2](#):



Some pins are omitted for clarity.

**Figure 70. Bipolar Output Range**

$$V_{OUT}(CODE) = \left[ \left( V_{REF} \times \frac{CODE}{2^{18}} \right) \left( 1 + \frac{R_3}{R_2} + \frac{R_3}{R_1} \right) - \left( V_{REF} \times \frac{R_3}{R_1} \right) \right]$$

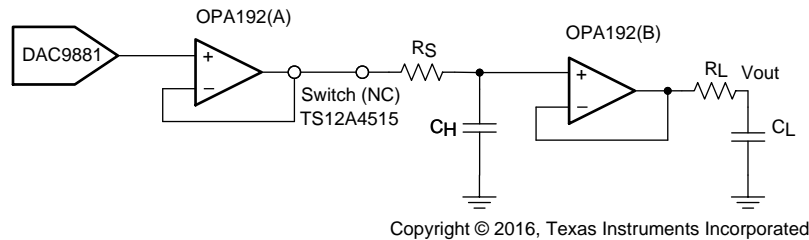
where

- $V_{OUT}(CODE)$  = output voltage vs code
  - $CODE = 0$  to 262143. This is the digital code loaded to the DAC
  - $V_{REF}$  = reference voltage applied to the DAC9881
- (2)

As an example, a  $\pm 8$ -V output span can be achieved by using values of 5 V, 6.25 k $\Omega$ , 16.67 k $\Omega$ , and 10 k $\Omega$  for  $V_{ref}$ ,  $R_1$ ,  $R_2$ , and  $R_3$  respectively.

## 8.2 Typical Application

### 8.2.1 DAC9881 Sample Hold Circuit



Copyright © 2016, Texas Instruments Incorporated

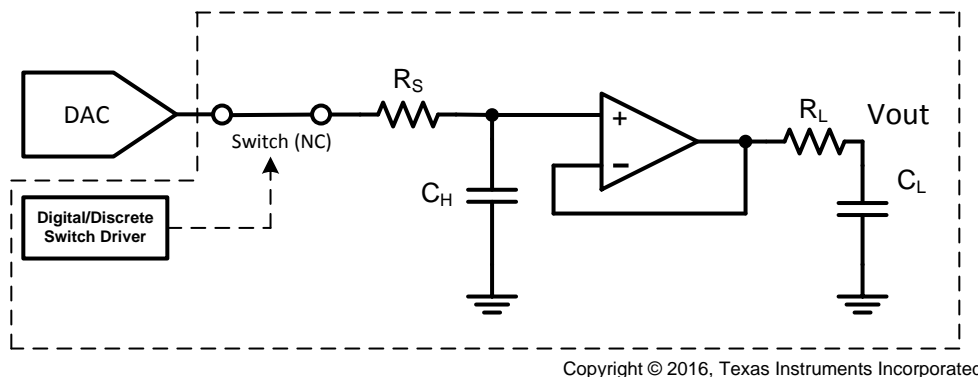
Figure 71. DAC9881 Sample and Hold Circuit

#### 8.2.1.1 Design Requirements

The inherent architecture of the DAC9881, which consists of an R-2R architecture, enables great performance in regards to noise and accuracy, but at a cost of large glitch area. Glitch area, also known as glitch impulse area, is defined as the area associated with the overshoot or undershoot created by a code transition, and is generally quantified in Volt-seconds. Different code-to-code transitions produce different levels of glitch impulses. DACs with R-2R architectures produce large glitches during major-carry transitions.

There are two methods that can be used to reduce this glitch area:

1. Add an external RC Filter to the output of the DAC.
  - The low-pass filter helps attenuate high-frequency glitches that would normally propagate to the DAC output. Best practice is to use a small resistor value, as large resistance develops a large potential drop and reduces the voltage seen at the load. Capacitor values can be determined from the desired cutoff frequency of the low-pass filter, as well as settling time.
2. Another technique is to employ a Sample and Hold (S&H) circuit following the DAC output.
  - In its simplest form, the sample and hold circuit can be constructed from the following components: a capacitive element, output buffer, and switch. A schematic of the simplified S&H is shown in Figure 72.



Copyright © 2016, Texas Instruments Incorporated

Figure 72. Simplified Sample and Hold Circuit

#### 8.2.1.2 Detailed Design Procedure

The Sample/Track and Hold modes of operation correspond to the state of the switch, which connects the DAC output to the hold capacitor  $C_H$ . In sample mode – also referred to as track mode -- the switch is closed, allowing the capacitor to charge or discharge to the sampled DAC output voltage. The operational amplifier is configured as a buffer, which tracks and relays the voltage seen across  $C_H$  to the output of the circuit. In hold mode, the switch opens, disconnecting  $C_H$  from the DAC output. The DAC is updated while the circuit is in hold mode, preventing any DAC major carry glitches from propagating to the S&H output. The capacitor retains the previous sampled voltage, and this value is buffered to the output of the circuit. In real circuits, switch leakage and operational amplifier input bias current must be considered as it will impact circuit performance. The switch is generally controlled by an external discrete or digital driver.

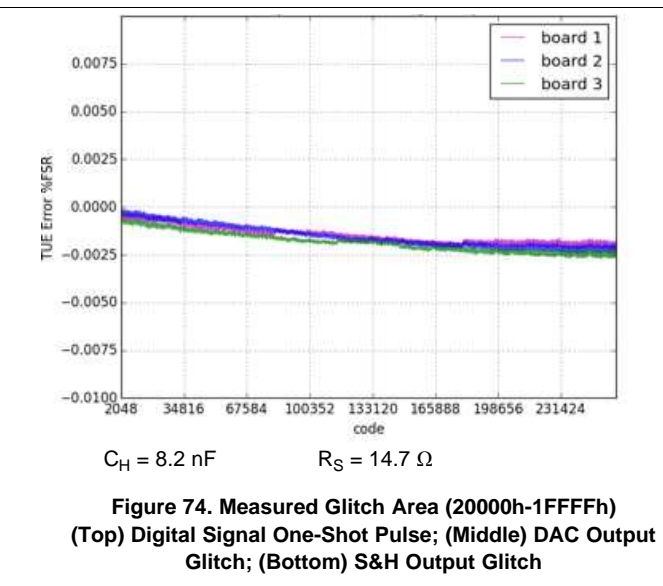
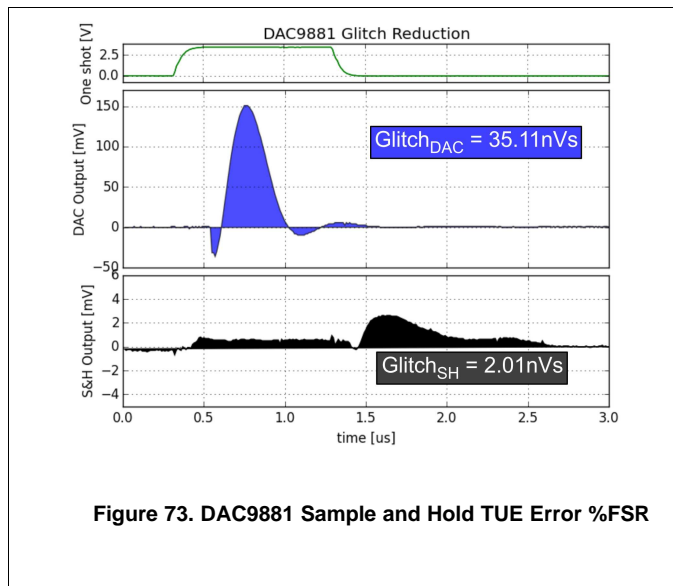
### Typical Application (continued)

Once the DAC glitch relays the switch closes and re-enters sample or track mode.

More information related to this circuit can be found in [Sample & Hold Glitch Reduction for Precision Outputs Design Guide](#) (TIDU022).

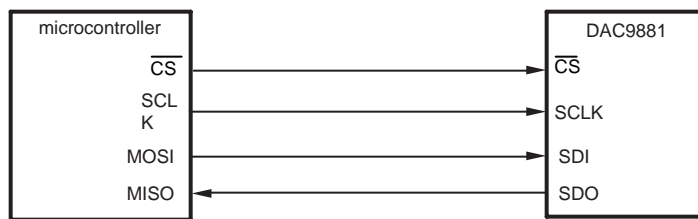
#### 8.2.1.3 Application Curves

Glitch reduction and total unadjusted error (TUE) plots of the solution presented in [Sample & Hold Glitch Reduction for Precision Outputs Design Guide](#) (TIDU022) is shown in the following plots. The glitch area is reduced from 35.11 nVs to 2.01 nVs.



### 8.3 System Example

Figure 75 displays a typical serial interface that may be used when connecting the DAC9881's SPI serial interface to a (master) microcontroller. The setup for the interface is as follows: The microcontroller's output SPI CLK drives the SCLK pin of the DAC9881, while the DAC9881 SDI pin is driven by the MOSI pin of the microcontroller. The CS pin of the DAC9881 can be asserted from a general program input/output pin of the microcontroller. When data are to be transmitted to the DAC9881, the CS pin is taken low. The data from the microcontroller is then transmitted to the DAC9881, totaling 24 bits latched into the DAC9881 device through the negative edge of SCLK. CS is then brought high after the completed write. The DAC9881 requires its data with the MSB as the first bit received.



Copyright © 2016, Texas Instruments Incorporated

**Figure 75. Simplified Sample and Hold Circuit**

## 9 Power Supply Recommendations

The DAC9881 can operate within the specified supply voltage range of 2.7 V to 5.5 V. The power applied to AVDD should be well regulated and low noise. Switching power supplies and DC-DC converters often have high-frequency glitches or spikes riding on the output voltage. In addition, digital components can create similar high frequency spikes. This noise can easily couple into the DAC output voltage through various paths between the power connections and analog output. To further minimize noise from the power supply, a strong recommendation is to include a 1- $\mu$ F to 10- $\mu$ F capacitor and 0.1- $\mu$ F bypass capacitor. The current consumption on the AVDD pin, the short-circuit current limit, and the load current for the device is listed in [Electrical Characteristics](#). The power supply must meet the aforementioned current requirements.

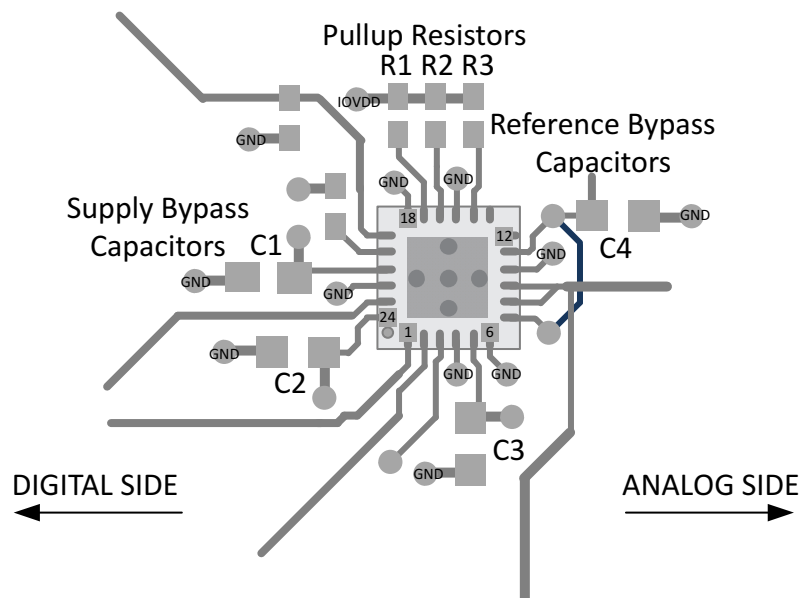
## 10 Layout

### 10.1 Layout Guidelines

A precision analog component requires careful layout, the list below provides some insight into good layout practices.

- All Power Supply pins should be bypassed to ground with a low ESR ceramic bypass capacitor. The typical recommended bypass capacitance is 0.1 to 0.22  $\mu$ F ceramic with a X7R or NP0 dielectric.
- Power supplies and VrefH/L bypass capacitors should be placed close to terminals to minimize inductance and optimize performance.
- A high-quality ceramic type NP0 or X7R is recommended for its optimal performance across temperature, and very low dissipation factor.
- The digital and analog sections should have proper placement with respect to the digital pins and analog pins of the DAC9881 device. The separation of analog and digital blocks will allow for better design and practice as it will ensure less coupling into neighboring blocks, and will minimize the interaction between analog and digital return currents.

### 10.2 Layout Example



**Figure 76. DAC9881 Basic Layout Example**

## 11 Device and Documentation Support

### 11.1 Documentation Support

#### 11.1.1 Related Documentation

For related documentation see the following:

- [DAC9881 Evaluation Module](#) (SLAU279)
- [Sample & Hold Glitch Reduction for Precision Outputs Design Guide](#) (TIDU022)

#### 11.2 Receiving Notification of Documentation Updates

To receive notification of documentation updates, navigate to the device product folder on ti.com. In the upper right corner, click on *Alert me* to register and receive a weekly digest of any product information that has changed. For change details, review the revision history included in any revised document.

#### 11.3 Community Resource

The following links connect to TI community resources. Linked contents are provided "AS IS" by the respective contributors. They do not constitute TI specifications and do not necessarily reflect TI's views; see TI's [Terms of Use](#).

**TI E2E™ Online Community** *TI's Engineer-to-Engineer (E2E) Community*. Created to foster collaboration among engineers. At e2e.ti.com, you can ask questions, share knowledge, explore ideas and help solve problems with fellow engineers.

**Design Support** *TI's Design Support* Quickly find helpful E2E forums along with design support tools and contact information for technical support.

#### 11.4 Trademarks

E2E is a trademark of Texas Instruments.

QSPI is a trademark of Motorola, Inc.

All other trademarks are the property of their respective owners.

#### 11.5 Electrostatic Discharge Caution



These devices have limited built-in ESD protection. The leads should be shorted together or the device placed in conductive foam during storage or handling to prevent electrostatic damage to the MOS gates.

#### 11.6 Glossary






[SLYZ022](#) — *TI Glossary*.

This glossary lists and explains terms, acronyms, and definitions.

## 12 Mechanical, Packaging, and Orderable Information

The following pages include mechanical, packaging, and orderable information. This information is the most current data available for the designated devices. This data is subject to change without notice and revision of this document. For browser-based versions of this data sheet, refer to the left-hand navigation.

**PACKAGING INFORMATION**

Orderable Device	Status (1)	Package Type	Package Drawing	Pins	Package Qty	Eco Plan (2)	Lead/Ball Finish (6)	MSL Peak Temp (3)	Op Temp (°C)	Device Marking (4/5)	Samples
DAC9881SBRGER	ACTIVE	VQFN	RGE	24	3000	Green (RoHS & no Sb/Br)	CU NIPDAU	Level-2-260C-1 YEAR	-40 to 105	DAC 9881 B	
DAC9881SBRGET	ACTIVE	VQFN	RGE	24	250	Green (RoHS & no Sb/Br)	CU NIPDAU	Level-2-260C-1 YEAR	-40 to 105	DAC 9881 B	
DAC9881SRGER	ACTIVE	VQFN	RGE	24	3000	Green (RoHS & no Sb/Br)	CU NIPDAU	Level-2-260C-1 YEAR	-40 to 105	DAC 9881	
DAC9881SRGET	ACTIVE	VQFN	RGE	24	250	Green (RoHS & no Sb/Br)	CU NIPDAU	Level-2-260C-1 YEAR	-40 to 105	DAC 9881	
DAC9881SRGETG4	ACTIVE	VQFN	RGE	24	250	Green (RoHS & no Sb/Br)	CU NIPDAU	Level-2-260C-1 YEAR	-40 to 105	DAC 9881	

(1) The marketing status values are defined as follows:

**ACTIVE:** Product device recommended for new designs.

**LIFEBUY:** TI has announced that the device will be discontinued, and a lifetime-buy period is in effect.

**NRND:** Not recommended for new designs. Device is in production to support existing customers, but TI does not recommend using this part in a new design.

**PREVIEW:** Device has been announced but is not in production. Samples may or may not be available.

**OBSOLETE:** TI has discontinued the production of the device.

(2) Eco Plan - The planned eco-friendly classification: Pb-Free (RoHS), Pb-Free (RoHS Exempt), or Green (RoHS & no Sb/Br) - please check <http://www.ti.com/productcontent> for the latest availability information and additional product content details.

**TBD:** The Pb-Free/Green conversion plan has not been defined.

**Pb-Free (RoHS):** TI's terms "Lead-Free" or "Pb-Free" mean semiconductor products that are compatible with the current RoHS requirements for all 6 substances, including the requirement that lead not exceed 0.1% by weight in homogeneous materials. Where designed to be soldered at high temperatures, TI Pb-Free products are suitable for use in specified lead-free processes.

**Pb-Free (RoHS Exempt):** This component has a RoHS exemption for either 1) lead-based flip-chip solder bumps used between the die and package, or 2) lead-based die adhesive used between the die and leadframe. The component is otherwise considered Pb-Free (RoHS compatible) as defined above.

**Green (RoHS & no Sb/Br):** TI defines "Green" to mean Pb-Free (RoHS compatible), and free of Bromine (Br) and Antimony (Sb) based flame retardants (Br or Sb do not exceed 0.1% by weight in homogeneous material)

(3) MSL, Peak Temp. - The Moisture Sensitivity Level rating according to the JEDEC industry standard classifications, and peak solder temperature.

(4) There may be additional marking, which relates to the logo, the lot trace code information, or the environmental category on the device.

(5) Multiple Device Markings will be inside parentheses. Only one Device Marking contained in parentheses and separated by a "~" will appear on a device. If a line is indented then it is a continuation of the previous line and the two combined represent the entire Device Marking for that device.

<sup>(6)</sup> Lead/Ball Finish - Orderable Devices may have multiple material finish options. Finish options are separated by a vertical ruled line. Lead/Ball Finish values may wrap to two lines if the finish value exceeds the maximum column width.

**Important Information and Disclaimer:** The information provided on this page represents TI's knowledge and belief as of the date that it is provided. TI bases its knowledge and belief on information provided by third parties, and makes no representation or warranty as to the accuracy of such information. Efforts are underway to better integrate information from third parties. TI has taken and continues to take reasonable steps to provide representative and accurate information but may not have conducted destructive testing or chemical analysis on incoming materials and chemicals. TI and TI suppliers consider certain information to be proprietary, and thus CAS numbers and other limited information may not be available for release.

In no event shall TI's liability arising out of such information exceed the total purchase price of the TI part(s) at issue in this document sold by TI to Customer on an annual basis.

## TAPE AND REEL INFORMATION



### QUADRANT ASSIGNMENTS FOR PIN 1 ORIENTATION IN TAPE



\*All dimensions are nominal

Device	Package Type	Package Drawing	Pins	SPQ	Reel Diameter (mm)	Reel Width W1 (mm)	A0 (mm)	B0 (mm)	K0 (mm)	P1 (mm)	W (mm)	Pin1 Quadrant
DAC9881SBRGER	VQFN	RGE	24	3000	330.0	12.4	4.3	4.3	1.5	8.0	12.0	Q2
DAC9881SBRGET	VQFN	RGE	24	250	180.0	12.4	4.3	4.3	1.5	8.0	12.0	Q2
DAC9881SRGER	VQFN	RGE	24	3000	330.0	12.4	4.3	4.3	1.5	8.0	12.0	Q2
DAC9881SRGET	VQFN	RGE	24	250	180.0	12.4	4.3	4.3	1.5	8.0	12.0	Q2

**TAPE AND REEL BOX DIMENSIONS**


\*All dimensions are nominal

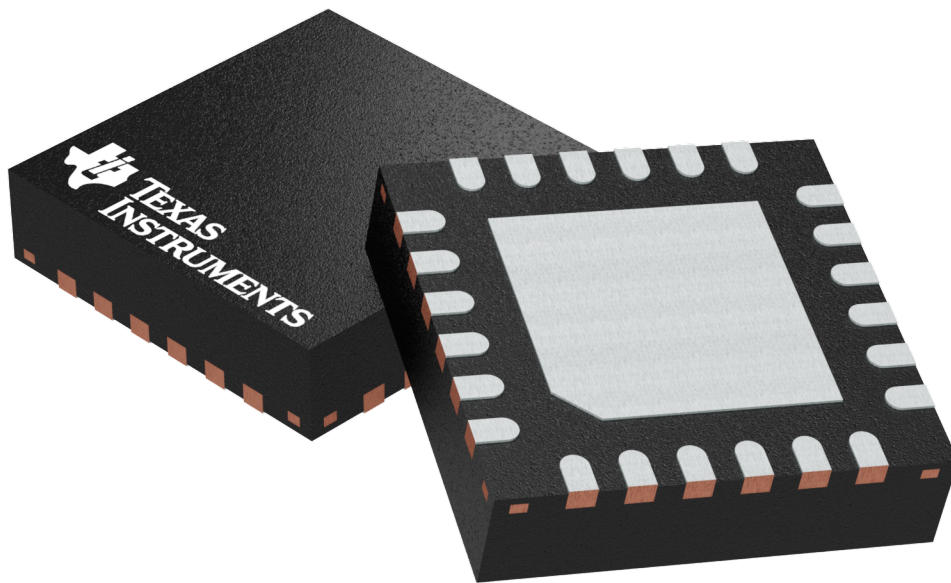
Device	Package Type	Package Drawing	Pins	SPQ	Length (mm)	Width (mm)	Height (mm)
DAC9881SBRGER	VQFN	RGE	24	3000	350.0	350.0	43.0
DAC9881SBRGET	VQFN	RGE	24	250	210.0	185.0	35.0
DAC9881SRGER	VQFN	RGE	24	3000	350.0	350.0	43.0
DAC9881SRGET	VQFN	RGE	24	250	210.0	185.0	35.0

## GENERIC PACKAGE VIEW

RGE 24

VQFN - 1 mm max height

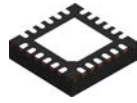
PLASTIC QUAD FLATPACK - NO LEAD



Images above are just a representation of the package family, actual package may vary.  
Refer to the product data sheet for package details.

4204104/H

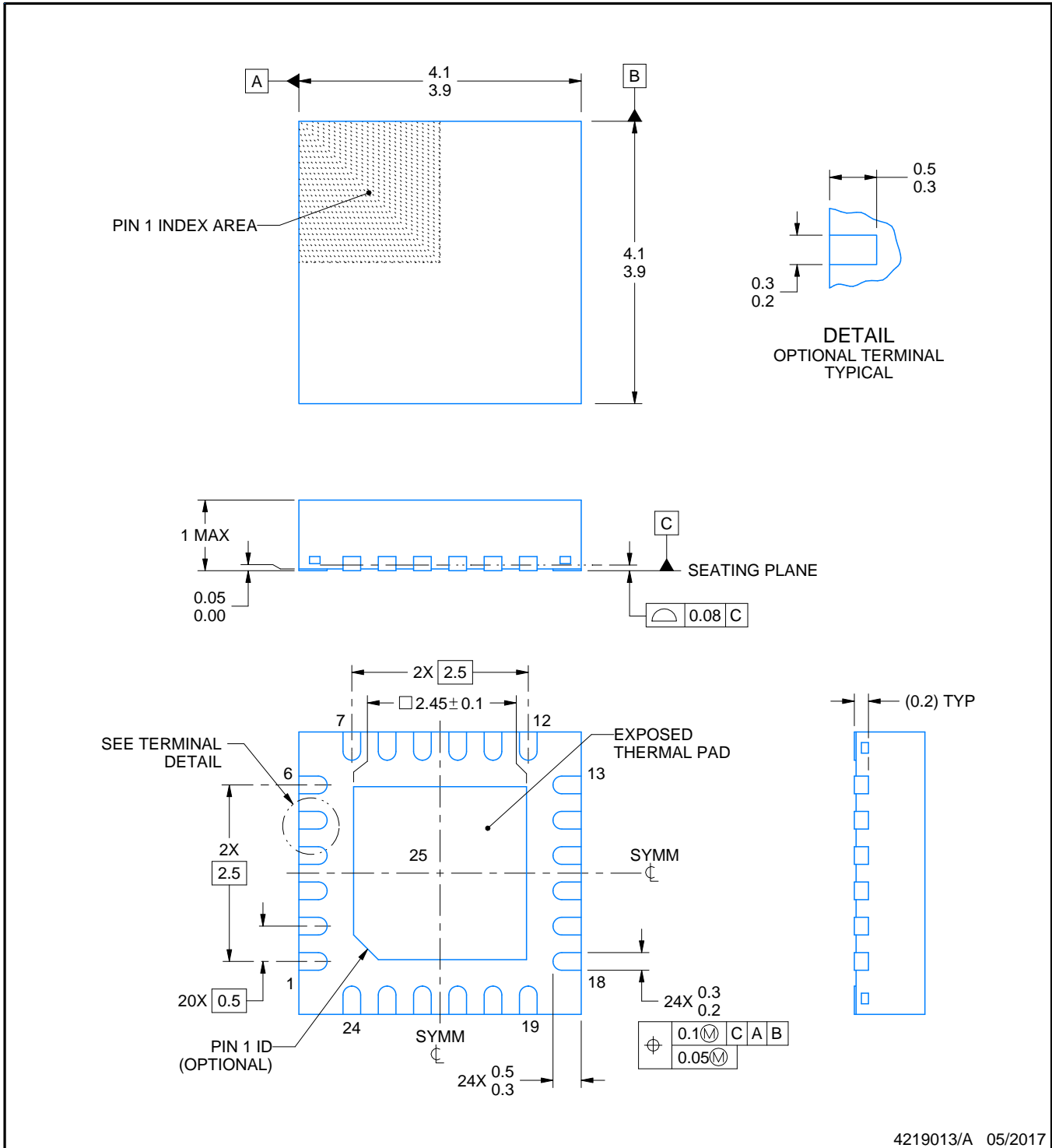
# RGE0024B



# PACKAGE OUTLINE

## VQFN - 1 mm max height

PLASTIC QUAD FLATPACK - NO LEAD



4219013/A 05/2017

### NOTES:

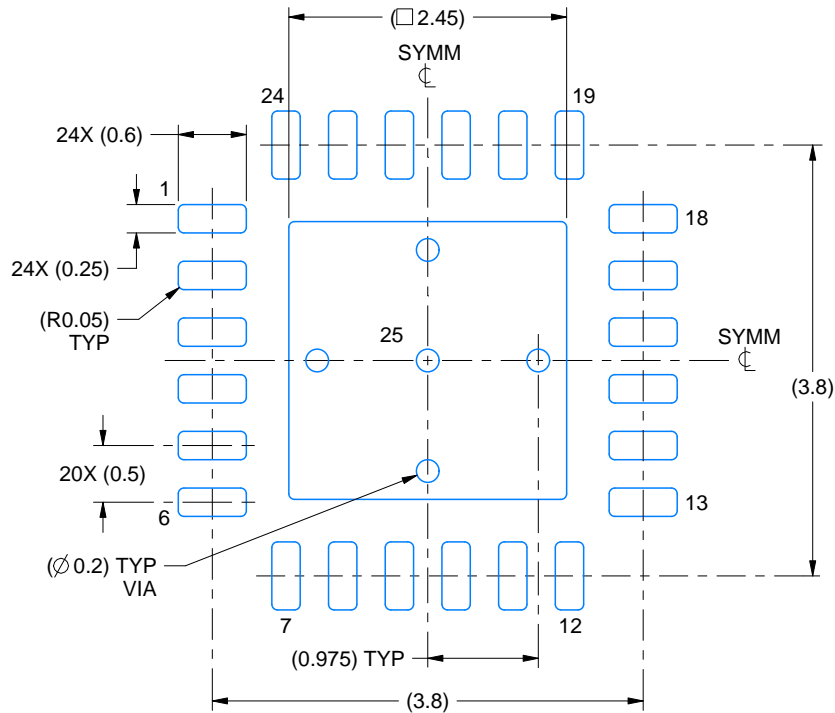
1. All linear dimensions are in millimeters. Any dimensions in parenthesis are for reference only. Dimensioning and tolerancing per ASME Y14.5M.
2. This drawing is subject to change without notice.
3. The package thermal pad must be soldered to the printed circuit board for thermal and mechanical performance.

# EXAMPLE BOARD LAYOUT

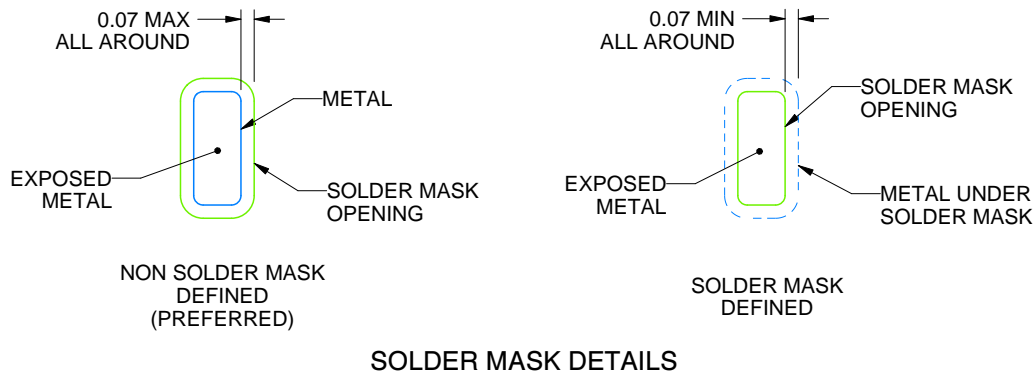
RGE0024B

VQFN - 1 mm max height

PLASTIC QUAD FLATPACK - NO LEAD



LAND PATTERN EXAMPLE  
EXPOSED METAL SHOWN  
SCALE:15X



SOLDER MASK DETAILS

4219013/A 05/2017

NOTES: (continued)

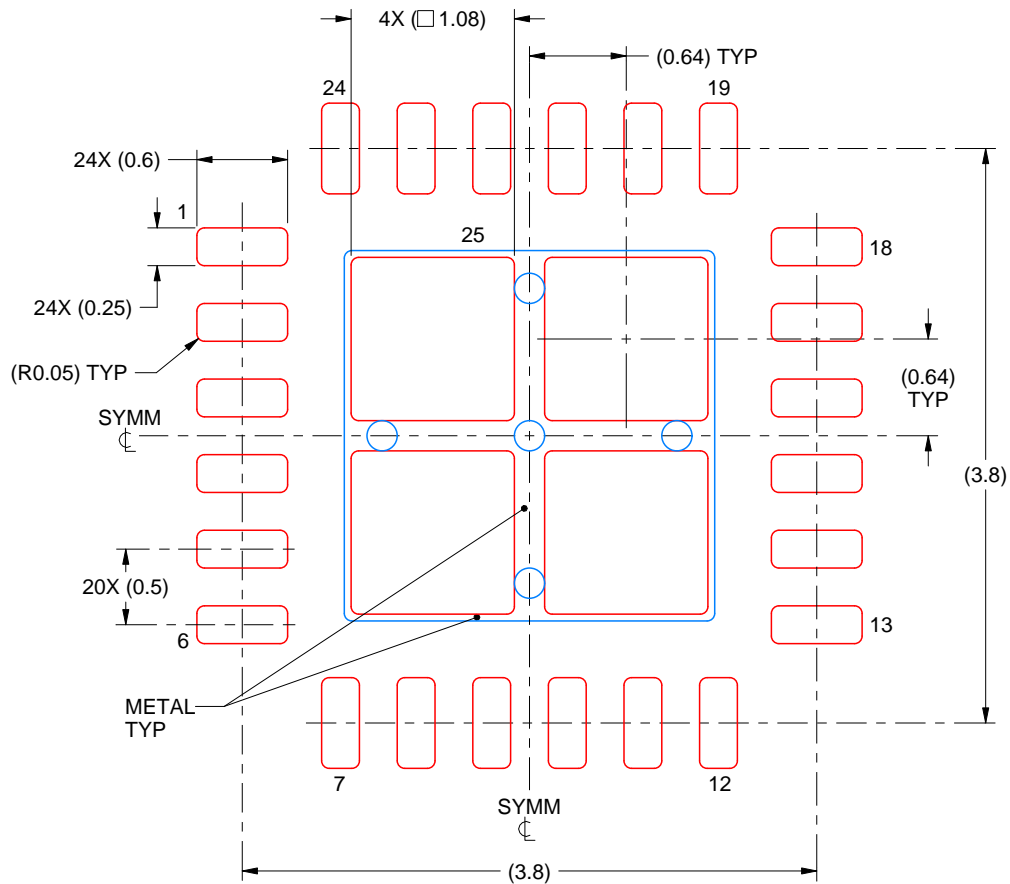
4. This package is designed to be soldered to a thermal pad on the board. For more information, see Texas Instruments literature number SLUA271 ([www.ti.com/lit/sluea271](http://www.ti.com/lit/sluea271)).
5. Vias are optional depending on application, refer to device data sheet. If any vias are implemented, refer to their locations shown on this view. It is recommended that vias under paste be filled, plugged or tented.

# EXAMPLE STENCIL DESIGN

RGE0024B

VQFN - 1 mm max height

PLASTIC QUAD FLATPACK - NO LEAD



**SOLDER PASTE EXAMPLE**  
 BASED ON 0.125 mm THICK STENCIL

EXPOSED PAD 25  
 78% PRINTED SOLDER COVERAGE BY AREA UNDER PACKAGE  
 SCALE:20X

4219013/A 05/2017

NOTES: (continued)

6. Laser cutting apertures with trapezoidal walls and rounded corners may offer better paste release. IPC-7525 may have alternate design recommendations.

## IMPORTANT NOTICE AND DISCLAIMER

TI PROVIDES TECHNICAL AND RELIABILITY DATA (INCLUDING DATASHEETS), DESIGN RESOURCES (INCLUDING REFERENCE DESIGNS), APPLICATION OR OTHER DESIGN ADVICE, WEB TOOLS, SAFETY INFORMATION, AND OTHER RESOURCES "AS IS" AND WITH ALL FAULTS, AND DISCLAIMS ALL WARRANTIES, EXPRESS AND IMPLIED, INCLUDING WITHOUT LIMITATION ANY IMPLIED WARRANTIES OF MERCHANTABILITY, FITNESS FOR A PARTICULAR PURPOSE OR NON-INFRINGEMENT OF THIRD PARTY INTELLECTUAL PROPERTY RIGHTS.

These resources are intended for skilled developers designing with TI products. You are solely responsible for (1) selecting the appropriate TI products for your application, (2) designing, validating and testing your application, and (3) ensuring your application meets applicable standards, and any other safety, security, or other requirements. These resources are subject to change without notice. TI grants you permission to use these resources only for development of an application that uses the TI products described in the resource. Other reproduction and display of these resources is prohibited. No license is granted to any other TI intellectual property right or to any third party intellectual property right. TI disclaims responsibility for, and you will fully indemnify TI and its representatives against, any claims, damages, costs, losses, and liabilities arising out of your use of these resources.

TI's products are provided subject to TI's Terms of Sale ([www.ti.com/legal/termsofsale.html](http://www.ti.com/legal/termsofsale.html)) or other applicable terms available either on [ti.com](http://ti.com) or provided in conjunction with such TI products. TI's provision of these resources does not expand or otherwise alter TI's applicable warranties or warranty disclaimers for TI products.

Mailing Address: Texas Instruments, Post Office Box 655303, Dallas, Texas 75265  
Copyright © 2019, Texas Instruments Incorporated

## Looking for pricing, stock, or lifecycle information?

Click below to explore more details on WIN SOURCE:

 [View DAC9881SBRGER on WIN SOURCE](#)

 [Texas Instruments](#) Information

## Optimize Your Supply Chain with WIN SOURCE Solutions

-  Global Sourcing Solution
-  Obsolete Management
-  Cost Control Management
-  Shortage Management
-  Alternative Solution
-  Excess Inventory Management