



**THE DATASHEET OF
DM74LS90N**



DM74LS90 Decade and Binary Counters

General Description

Each of these monolithic counters contains four master-slave flip-flops and additional gating to provide a divide-by-two counter and a three-stage binary counter for which the count cycle length is divide-by-five for the DM74LS90.

All of these counters have a gated zero reset and the DM74LS90 also has gated set-to-nine inputs for use in BCD nine's complement applications.

To use their maximum count length (decade or four bit binary), the B input is connected to the Q_A output. The input count pulses are applied to input A and the outputs are as described in the appropriate truth table. A symmetrical divide-by-ten count can be obtained from the DM74LS90 counters by connecting the Q_D output to the A input and applying the input count to the B input which gives a divide-by-ten square wave at output Q_A.

Features

- Typical power dissipation 45 mW
- Count frequency 42 MHz

Ordering Code:

Order Number	Package Number	Package Description
DM74LS90M	M14A	14-Lead Small Outline Integrated Circuit (SOIC), JEDEC MS-120, 0.150 Narrow
DM74LS90N	N14A	14-Lead Plastic Dual-In-Line Package (PDIP), JEDEC MS-001, 0.300 Wide

Devices also available in Tape and Reel. Specify by appending the suffix letter "X" to the ordering code.

Connection Diagram

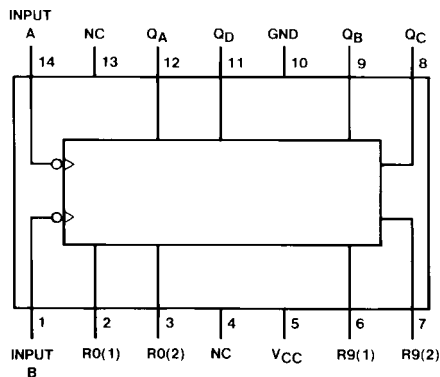

Reset/Count Truth Table

Reset Inputs				Output			
R0(1)	R0(2)	R9(1)	R9(2)	Q _D	Q _C	Q _B	Q _A
H	H	L	X	L	L	L	L
H	H	X	L	L	L	L	L
X	X	H	H	H	L	L	H
X	L	X	L	COUNT			
L	X	L	X	COUNT			
L	X	X	L	COUNT			
X	L	L	X	COUNT			

Function Tables

BCD Count Sequence (Note 1)

Count	Output			
	Q _D	Q _C	Q _B	Q _A
0	L	L	L	L
1	L	L	L	H
2	L	L	H	L
3	L	L	H	H
4	L	H	L	L
5	L	H	L	H
6	L	H	H	L
7	L	H	H	H
8	H	L	L	L
9	H	L	L	H

Bi-Quinary (5-2) (Note 2)

Count	Output			
	Q _A	Q _D	Q _C	Q _B
0	L	L	L	L
1	L	L	L	H
2	L	L	H	L
3	L	L	H	H
4	L	H	L	L
5	H	L	L	L
6	H	L	L	H
7	H	L	H	L
8	H	L	H	H
9	H	H	L	L

H = HIGH Level
 L = LOW Level
 X = Don't Care

Note 1: Output Q_A is connected to input B for BCD count.

Note 2: Output Q_D is connected to input A for bi-quinary count.

Note 3: Output Q_A is connected to input B.

Logic Diagram

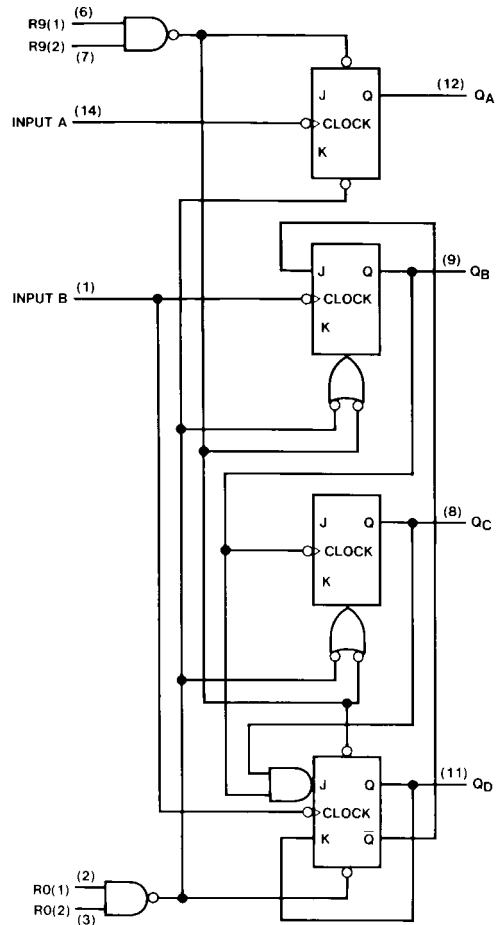

The J and K inputs shown without connection are for reference only and are functionally at a high level.

Absolute Maximum Ratings(Note 4)

Supply Voltage	7V
Input Voltage (Reset)	7V
Input Voltage (A or B)	5.5V
Operating Free Air Temperature Range	0°C to +70°C
Storage Temperature Range	-65°C to +150°C

Note 4: The "Absolute Maximum Ratings" are those values beyond which the safety of the device cannot be guaranteed. The device should not be operated at these limits. The parametric values defined in the "Electrical Characteristics" table are not guaranteed at the absolute maximum ratings. The "Recommended Operating Conditions" table will define the conditions for actual device operation.

Recommended Operating Conditions

Symbol	Parameter	Min	Nom	Max	Units
V_{CC}	Supply Voltage	4.75	5	5.25	V
V_{IH}	HIGH Level Input Voltage	2			V
V_{IL}	LOW Level Input Voltage			0.8	V
I_{OH}	HIGH Level Output Current			-0.4	mA
I_{OL}	LOW Level Output Current			8	mA
f_{CLK}	Clock Frequency (Note 5)	A to Q_A	0	32	MHz
		B to Q_B	0	16	
f_{CLK}	Clock Frequency (Note 6)	A to Q_A	0	20	MHz
		B to Q_B	0	10	
t_W	Pulse Width (Note 5)	A	15		ns
		B	30		
		Reset	15		
t_W	Pulse Width (Note 6)	A	25		ns
		B	50		
		Reset	25		
t_{REL}	Reset Release Time (Note 5)	25			ns
t_{REL}	Reset Release Time (Note 6)	35			ns
T_A	Free Air Operating Temperature	0		70	°C

Note 5: $C_L = 15$ pF, $R_L = 2$ k Ω , $T_A = 25^\circ\text{C}$ and $V_{CC} = 5$ V.

Note 6: $C_L = 50$ pF, $R_L = 2$ k Ω , $T_A = 25^\circ\text{C}$ and $V_{CC} = 5$ V.

Electrical Characteristics

over recommended operating free air temperature range (unless otherwise noted)

Symbol	Parameter	Conditions	Min	Typ (Note 7)	Max	Units
V_I	Input Clamp Voltage	$V_{CC} = \text{Min}$, $I_I = -18$ mA			-1.5	V
V_{OH}	HIGH Level Output Voltage	$V_{CC} = \text{Min}$, $I_{OH} = \text{Max}$ $V_{IL} = \text{Max}$, $V_{IH} = \text{Min}$	2.7	3.4		V
V_{OL}	LOW Level Output Voltage	$V_{CC} = \text{Min}$, $I_{OL} = \text{Max}$ $V_{IL} = \text{Max}$, $V_{IH} = \text{Min}$ (Note 8) $I_{OL} = 4$ mA, $V_{CC} = \text{Min}$		0.35 0.25	0.5 0.4	V
I_I	Input Current @ Max Input Voltage	$V_{CC} = \text{Max}$, $V_I = 7$ V $V_{CC} = \text{Max}$ $V_I = 5.5$ V			0.1 0.2 0.4	mA
I_{IH}	HIGH Level Input Current	$V_{CC} = \text{Max}$, $V_I = 2.7$ V			20 40 80	μA
I_{IL}	LOW Level Input Current	$V_{CC} = \text{Max}$, $V_I = 0.4$ V			-0.4 -2.4 -3.2	mA
I_{OS}	Short Circuit Output Current	$V_{CC} = \text{Max}$ (Note 9)	-20		-100	mA
I_{CC}	Supply Current	$V_{CC} = \text{Max}$ (Note 7)		9	15	mA

Note 7: All typicals are at $V_{CC} = 5$ V, $T_A = 25^\circ\text{C}$.

Electrical Characteristics (Continued)

Note 8: Q_A outputs are tested at $I_{OL} = \text{Max}$ plus the limit value of I_{IL} for the B input. This permits driving the B input while maintaining full fan-out capability.

Note 9: Not more than one output should be shorted at a time, and the duration should not exceed one second.

Note 10: I_{CC} is measured with all outputs open, both RO inputs grounded following momentary connection to 4.5V and all other inputs grounded.

Switching Characteristics at $V_{CC} = 5V$ and $T_A = 25^\circ\text{C}$

Symbol	Parameter	From (Input) To (Output)	$R_L = 2\text{ k}\Omega$				Units
			$C_L = 15\text{ pF}$		$C_L = 50\text{ pF}$		
			Min	Max	Min	Max	
f_{MAX}	Maximum Clock Frequency	A to Q_A	32		20		MHz
		B to Q_B	16		10		
t_{PLH}	Propagation Delay Time LOW-to-HIGH Level Output	A to Q_A		16		20	ns
t_{PHL}	Propagation Delay Time HIGH-to-LOW Level Output	A to Q_A		18		24	ns
t_{PLH}	Propagation Delay Time LOW-to-HIGH Level Output	A to Q_D		48		52	ns
t_{PHL}	Propagation Delay Time HIGH-to-LOW Level Output	A to Q_D		50		60	ns
t_{PLH}	Propagation Delay Time LOW-to-HIGH Level Output	B to Q_B		16		23	ns
t_{PHL}	Propagation Delay Time HIGH-to-LOW Level Output	B to Q_B		21		30	ns
t_{PLH}	Propagation Delay Time LOW-to-HIGH Level Output	B to Q_C		32		37	ns
t_{PHL}	Propagation Delay Time HIGH-to-LOW Level Output	B to Q_C		35		44	ns
t_{PLH}	Propagation Delay Time LOW-to-HIGH Level Output	B to Q_D		32		36	ns
t_{PHL}	Propagation Delay Time HIGH-to-LOW Level Output	B to Q_D		35		44	ns
t_{PLH}	Propagation Delay Time LOW-to-HIGH Level Output	SET-9 to Q_A, Q_D		30		35	ns
t_{PHL}	Propagation Delay Time HIGH-to-LOW Level Output	SET-9 to Q_B, Q_C		40		48	ns
t_{PHL}	Propagation Delay Time HIGH-to-LOW Level Output	SET-0 to Any Q		40		52	ns

Physical Dimensions inches (millimeters) unless otherwise noted

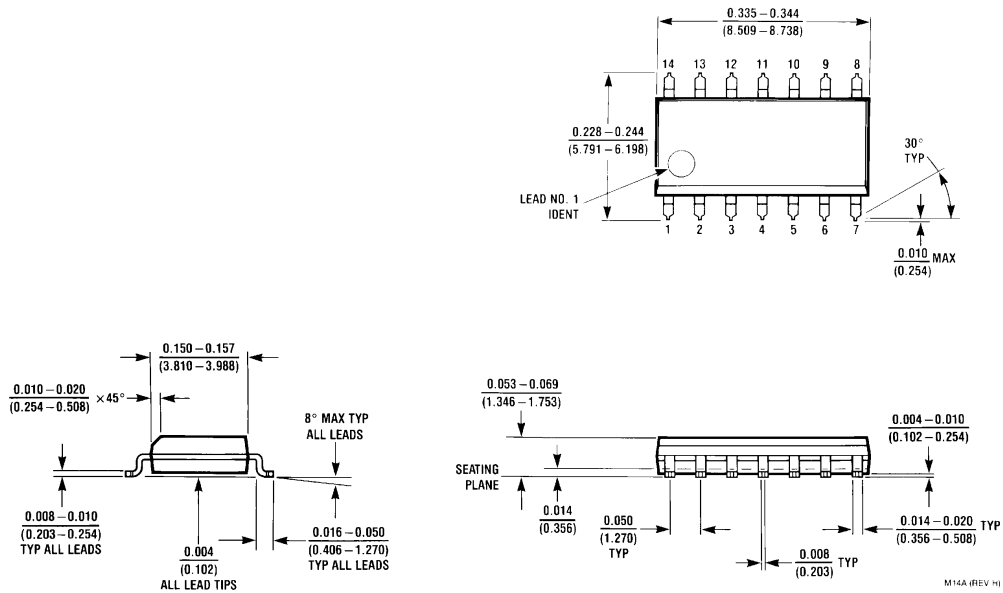

**14-Lead Small Outline Integrated Circuit (SOIC), JEDEC MS-120, 0.150 Narrow
Package Number M14A**

Physical Dimensions inches (millimeters) unless otherwise noted (Continued)

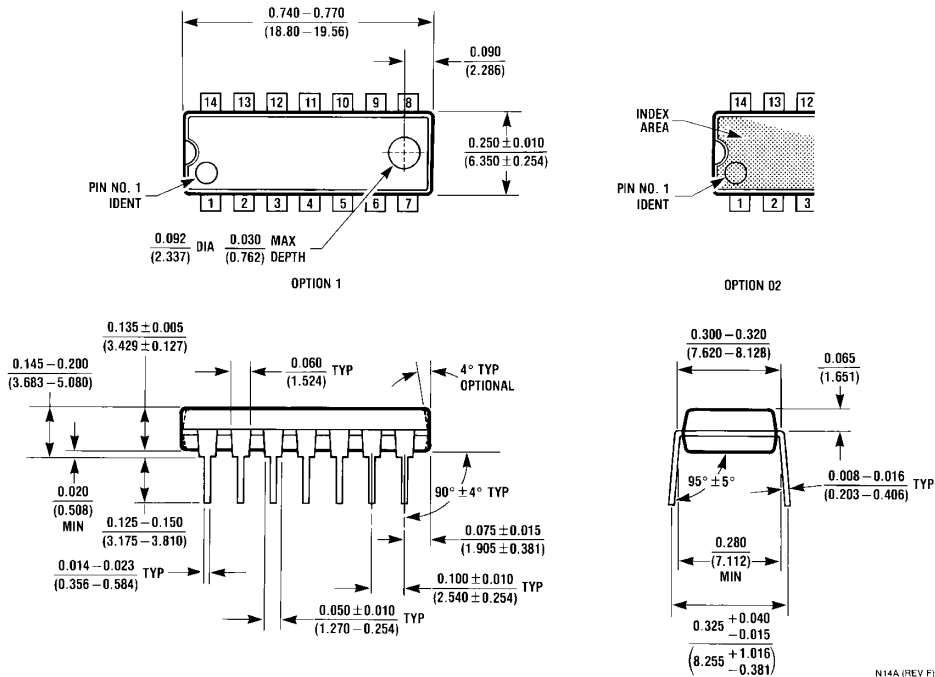

14-Lead Plastic Dual-In-Line Package (PDIP), JEDEC MS-001, 0.300 Wide Package Number N14A

Fairchild does not assume any responsibility for use of any circuitry described, no circuit patent licenses are implied and Fairchild reserves the right at any time without notice to change said circuitry and specifications.

LIFE SUPPORT POLICY



FAIRCHILD'S PRODUCTS ARE NOT AUTHORIZED FOR USE AS CRITICAL COMPONENTS IN LIFE SUPPORT DEVICES OR SYSTEMS WITHOUT THE EXPRESS WRITTEN APPROVAL OF THE PRESIDENT OF FAIRCHILD SEMICONDUCTOR CORPORATION. As used herein:

1. Life support devices or systems are devices or systems which, (a) are intended for surgical implant into the body, or (b) support or sustain life, and (c) whose failure to perform when properly used in accordance with instructions for use provided in the labeling, can be reasonably expected to result in a significant injury to the user.
2. A critical component in any component of a life support device or system whose failure to perform can be reasonably expected to cause the failure of the life support device or system, or to affect its safety or effectiveness.

www.fairchildsemi.com

Looking for pricing, stock, or lifecycle information?

Click below to explore more details on WIN SOURCE:

-  [View DM74LS90N on WIN SOURCE](#)
-  [Fairchild/ON Semiconductor Information](#)

Optimize Your Supply Chain with WIN SOURCE Solutions

-  Global Sourcing Solution
-  Obsolete Management
-  Cost Control Management
-  Shortage Management
-  Alternative Solution
-  Excess Inventory Management