



**THE DATASHEET OF
AFE8220TPZPQ1**



DUAL INTERMEDIATE FREQUENCY (IF) ANALOG FRONT END FOR DIGITAL RADIO

FEATURES

- Qualified for Automotive Applications
- Two Intermediate Frequency (IF) Analog-to-Digital Converters (ADCs)
- Two 12-Bit Auxiliary Digital-to-Analog Converters (DACs)
- Integrated IF Digital Processing Core
- Integrated Circuitry for Third-Overtone Master Clock Oscillator
- Wakeup Circuit/Real-Time Clock With Separate Crystal Oscillator
- Flexible Data Interface Optimized for TMS Family of Digital Baseband Processors
- Pin-Selectable SPI™ and I²C™ Control Interfaces
- 3.3-V/1.8-V Supply (Integrated Regulator Available to Optionally Generate 1.8-V Supply)
- TQFP-100 PowerPAD™ Package

APPLICATIONS

- IF-Sampled AM/FM Radio
- Hybrid Digital (HD) Digital Audio Broadcasting (DAB) Digital Radio

DESCRIPTION

The AFE8220 implements the intermediate frequency (IF) sampling and processing functions of a digital radio receiver system. It is designed to be used with TI's [digital radio baseband processors](#) and AM/FM tuners. The AFE8220 can also be programmed by the baseband processor for use in conventional AM/FM and digital radio. This unit includes two IF inputs with associated filtering and digital processing circuitry.

The receive circuit oversamples the radio tuner IF output to reduce noise and improve dynamic range. The IF analog-to-digital converter (ADC) oversamples the IF input at rates up to 75 MHz. The AFE8220 then digitally mixes, filters, and decimates the signal to provide in-phase (I) and quadrature (Q) output signals to the baseband processor. A clock oscillator circuit is provided that can be used with an appropriate third-overtone crystal and external tank circuit to generate the sampling clock for the IF ADCs.

The AFE8220 also includes a real-time clock and associated low-power oscillator circuit. Two auxiliary digital-to-analog converters (DACs) are included for system control functions. Other features include eight general-purpose input/output (GPIO) lines and programmable interrupt generators.

The AFE8220 is available in a TQFP-100 (14 mm × 14 mm) package and uses a 3.3-V and a 1.8-V power supply. An onboard voltage regulator is included to optionally generate the 1.8-V digital supply for the AFE8220.

ORDERING INFORMATION⁽¹⁾

T _A	PACKAGE ⁽²⁾		ORDERABLE PART NUMBER	TOP-SIDE MARKING
–40°C to 85°C	HTQFP – PZP	Tray of 90	AFE8220IPZPQ1	AFE8220Q
–40°C to 105°C			AFE8220TPZPQ1	AFE8220QT

(1) For the most current package and ordering information, see the Package Option Addendum at the end of this document, or see the TI web site at www.ti.com.

(2) Package drawings, thermal data, and symbolization are available at www.ti.com/packaging.



Please be aware that an important notice concerning availability, standard warranty, and use in critical applications of Texas Instruments semiconductor products and disclaimers thereto appears at the end of this data sheet.

PowerPAD is a trademark of Texas Instruments.

SPI is a trademark of Motorola, Inc.

I²C is a trademark of NXP Semiconductors.

All other trademarks are the property of their respective owners.



This integrated circuit can be damaged by ESD. Texas Instruments recommends that all integrated circuits be handled with appropriate precautions. Failure to observe proper handling and installation procedures can cause damage.

ESD damage can range from subtle performance degradation to complete device failure. Precision integrated circuits may be more susceptible to damage because very small parametric changes could cause the device not to meet its published specifications.

ABSOLUTE MAXIMUM RATINGS

over operating free-air temperature range, unless otherwise noted.⁽¹⁾

Supply voltage range	AVDD	–0.5 V to 3.6 V
	DVDD	–0.5 V to 3.6 V
	IOVDD	–0.5 V to 3.6 V
Voltage between	AGND to DGND	–0.3 V to 0.5 V
	AVDD to DVDD	–3.3 V to 3.3 V
Digital inputs ⁽²⁾		–0.3 V to DVDD + 0.3 V
Digital data output		–0.3 V to DVDD + 0.3 V
Operating free-air temperature range, T _A	AFE8220I	–40°C to 85°C
	AFE8220T	–40°C to 105°C
Operating junction temperature range, T _J	AFE8220T	–40°C to 125°C
Storage temperature range, T _{stg}		–55°C to 125°C

(1) Stresses beyond those listed under *absolute maximum ratings* may cause permanent damage to the device. These are stress ratings only, and functional operation of the device at these or any other conditions beyond those indicated under *recommended operating conditions* is not implied. Exposure to absolute-maximum-rated conditions for extended periods may affect device reliability.

(2) Measured with respect to DGND.

RECOMMENDED OPERATING CONDITIONS

over operating free-air temperature range (unless otherwise noted)

		MIN	NOM	MAX	UNIT
AVDD	Analog supply voltage	3.14	3.3	3.6	V
DVDD	Digital supply voltage	1.6	1.8	2.0	V
IOVDD	Output driver supply voltage	1.6		3.6	V
	Input common-mode voltage	VCM			V
	Differential input peak-to-peak voltage range	2			V
V _{IH}	High-level digital input voltage	0.7 × IOVDD			V
V _{IL}	Low-level digital input voltage	0.25 × IOVDD			V
T _A	Operating free-air temperature	AFE8220I	–40	85	°C
		AFE8220T	–40	105	
T _J	Operating junction temperature	AFE8220T	–40	125	°C

POWER SUPPLY SPECIFICATIONS

$T_A = 25^\circ\text{C}$, $AVDD = IOVDD = 3.3\text{ V}$, $DVDD = 1.8\text{ V}$ (unless otherwise noted)

PARAMETER	TEST CONDITIONS	MIN	TYP	MAX	UNIT
Power Consumption					
Analog supply current			130	155	mA
Digital supply current	$\overline{\text{REG_ENB}}$ disabled		65	85	mA
Digital I/O supply current	$\overline{\text{REG_ENB}}$ disabled		35	50	mA
	$\overline{\text{REG_ENB}}$ enabled		105	125	mA
Power dissipation	$\overline{\text{REG_ENB}}$ disabled		660		mW
	$\overline{\text{REG_ENB}}$ enabled		725		mW
Reduced-Power Modes					
Software power-down	Control register address 1 set to 0x0000		100		mW
Hardware power-down	PWD enabled		50		μW

IF ADC SPECIFICATIONS

$T_A = 25^\circ\text{C}$, $AVDD = IOVDD = 3.3\text{ V}$, $DVDD = 1.8\text{ V}$, $f_S = 75\text{ MHz}$ (unless otherwise noted)

PARAMETER	TEST CONDITIONS	MIN	TYP	MAX	UNIT
DC Accuracy					
Input impedance			2		k Ω
Offset error			3.0		mV
Gain error			1.0		%FS
Full-scale input level	Peak differential, 1x gain		2.0		V
	Peak differential, 2x gain		1.0		V
Power Supply					
Power-supply rejection ratio, PSRR	$AVDD = 3.15\text{ VDC to }3.6\text{ VDC}$		72		dB
References					
Positive reference	REFP	1.9	2.0	2.1	V
Negative reference	REFN	0.9	1.0	1.1	V
Common-mode voltage	VCM	1.4	1.5	1.6	V
AC Performance					
Input sample rate		75			MHz
Signal-to-noise ratio within a limited passband	SNR	Input 10.7 MHz, -1 dBFS , in 3-kHz passband	105		dBc
		Input 10.7 MHz, -1 dBFS , in 100-kHz passband	85	90	
Third-order intermodulation distortion		-7-dB signals at 10.656 MHz and 10.729 MHz	91		dB
		-10-dB signals at 10.656 MHz and 10.729 MHz	94		
Spurious-free dynamic range	SFDR	-1-dB input at 10.7 MHz, 100-kHz passband	88	96	dBc

AUXILIARY DAC SPECIFICATIONS

$T_A = 25^\circ\text{C}$, $AVDD = IOVDD = 3.3\text{ V}$, $DVDD = 1.8\text{ V}$ (unless otherwise noted)

PARAMETER	TEST CONDITIONS	MIN	TYP	MAX	UNIT
Resolution					
Resolution			12		Bits
Output Voltage Range					
Output voltage range	Input code 0x000		0		V
	Input code 0x3FF		2.7		V
Settling Time					
Settling time	0.1% of FSR			10	μs
DC Performance					
Offset			± 1		% of FSR
Gain error			± 5		% of FSR
DNL	Monotonic		± 0.5		LSB
INL	Offset and gain errors removed		± 3.0		LSB
PSRR	Input code 0x200, $AVDD = 3.15\text{ VDC}$ to 3.6 VDC		30.0		dB

DIGITAL I/O SPECIFICATIONS

$T_A = 25^\circ\text{C}$, $IOVDD = 3.3\text{ V}$ (unless otherwise noted)

PARAMETER	TEST CONDITIONS	MIN	TYP	MAX	UNIT
I_{IH} High-level input current	$V_{IH} = 1.6\text{ V}$ to 3.6 V	-10		10	μA
I_{IL} Low-level input current	$V_{IL} = 0\text{ V}$ to 0.4 V	-10		10	μA
V_{OH} High-level output voltage	$I_{OH} = -50\ \mu\text{A}$	$0.8 \times IOVDD$			V
V_{OL} Low-level output voltage	$I_{OL} = 50\ \mu\text{A}$		$0.2 \times IOVDD$		V

CLOCK OSCILLATOR SPECIFICATIONS

$T_A = 25^\circ\text{C}$, $IOVDD = 1.8\text{ V}$, $DVDD = 1.8\text{ V}$ (unless otherwise noted)

PARAMETER	TEST CONDITIONS	MIN	TYP	MAX	UNIT
f_{XTAL} Crystal frequency	See the Master Clock Oscillator section	20		75	MHz

FUNCTIONAL BLOCK DIAGRAM

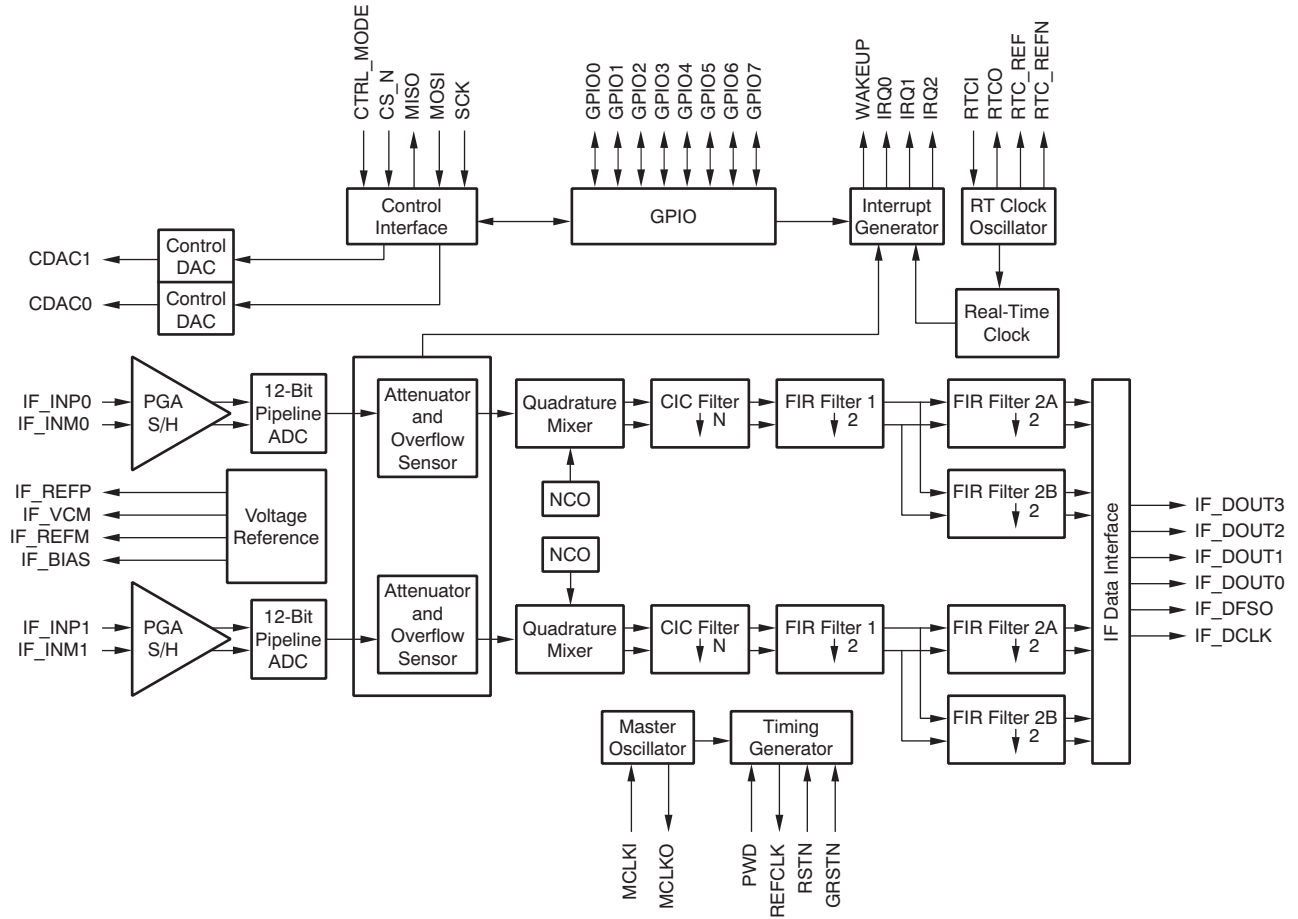

TERMINAL FUNCTIONS

TERMINAL		FUNCTION	DESCRIPTION
NAME	NO.		
AVDD1	1	Supply	3.3-V analog supply (internally switched)
CDAC0	2	Output	Control DAC 0 output
AVSS	3	Ground	Analog ground
CDAC1	4	Output	Control DAC 1 output
AVDD1	5	Supply	3.3-V analog supply (internally switched)
AVDD1	6	Supply	3.3-V analog supply (internally switched)
AVSS	7	Ground	Analog ground
AVSS	8	Ground	Analog ground
IF_INP0	9	Input	IF ADC channel 0 positive input
IF_INM0	10	Input	IF ADC channel 0 negative input
IF_VCM	11	Output	IF ADC common-mode voltage
IF_REFP	12	Output	IF ADC positive reference
IF_REFM	13	Output	IF ADC negative reference
AVSS	14	Ground	Analog ground
AVDD1	15	Supply	3.3-V analog supply (internally switched)
AVDD1	16	Supply	3.3-V analog supply (internally switched)
AVSS	17	Ground	Analog ground
AVSS	18	Ground	Analog ground
IF_BIAS	19	Input	IF ADC bias input
AVSS	20	Ground	Analog ground
IF_INM1	21	Input	IF ADC channel 1 negative input
IF_INP1	22	Input	IF ADC channel 1 positive input
AVSS	23	Ground	Analog ground
AVSS	24	Ground	Analog ground
AVDD1	25	Supply	3.3-V analog supply (internally switched)
AVDD	26	Supply	3.3-V analog supply
AVDD	27	Supply	3.3-V analog supply
AVSS	28	Ground	Analog ground
AVDD	29	Supply	3.3-V analog supply
$\overline{\text{REFCLK}}$	30	Output	Inverted reference clock output
REFCLK	31	Output	Reference clock output
AVSS	32	Ground	Analog ground
DVSS	33	Ground	Digital ground (for MCLK oscillator)
MCLKI	34	Input	MCLK oscillator input
MCLKO	35	Output	MCLK oscillator output
DVDD2	36	Supply	1.8-V digital supply (for MCLK oscillator)
AVSS	37	Ground	Analog ground
AVDD	38	Supply	3.3-V analog supply
AVSS	39	Ground	Analog ground
DVDD	40	Supply	1.8-V digital supply
IOVDD	41	Supply	3.3-V digital I/O supply
DVSS	42	Ground	Digital ground
IOVSS	43	Ground	Digital I/O ground
$\overline{\text{GRST}}$	44	Input	Global reset (active low)
WAKEUP	45	Output	WAKEUP interrupt output
IRQ0	46	Output	Interrupt output 0

TERMINAL FUNCTIONS (continued)

TERMINAL		FUNCTION	DESCRIPTION
NAME	NO.		
IRQ1	47	Output	Interrupt output 1
IRQ2	48	Output	Interrupt output 2
PWD	49	Input	Power down pin (active high)
$\overline{\text{RST}}$	50	Input	Reset pin (active low)
DVSS	51	Ground	Digital ground
DVDD	52	Supply	1.8-V digital supply
IOVSS	53	Ground	Digital I/O ground
IOVDD	54	Supply	3.3-V digital I/O supply
IF_DFSDO	55	Output	IF interface frame sync
IF_DCLK	56	Output	IF interface bit clock
IF_DOUT3	57	Output	IF interface data out 3
DVSS	58	Ground	Digital ground
DVDD	59	Supply	1.8-V digital supply
IF_DOUT2	60	Output	IF interface data out 2
IF_DOUT1	61	Output	IF interface data out 1
IF_DOUT0	62	Output	IF interface data out 0
IOVSS	63	Ground	Digital I/O ground
IOVDD	64	Supply	3.3-V digital I/O supply
$\overline{\text{CS}}/\text{A1}$	65	Input	SPI Chip select (active low) / I ² C address bit 1
MOSI/A0	66	Input	SPI data in / I ² C address bit 0
MISO/SDA	67	Bidirectional	SPI data out / I ² C SDA
SCK/SCL	68	Input	SPI clock / I ² C SCL
CTRL_MODE	69	Input	Control interface mode select (SPI = 0, I2C = 1)
$\overline{\text{REG_ENB}}$	70	Input	Enable onboard DVDD regulator (active low)
DVSS	71	Ground	Digital ground
DVDD	72	Supply	1.8-V digital supply
GPIO7	73	Bidirectional	GPIO 7
GPIO6	74	Bidirectional	GPIO 6
GPIO5	75	Bidirectional	GPIO 5
GPIO4	76	Bidirectional	GPIO 4
GPIO3	77	Bidirectional	GPIO 3
GPIO2	78	Bidirectional	GPIO 2
GPIO1	79	Bidirectional	GPIO 1
GPIO0	80	Bidirectional	GPIO 0
DVSS	81	Ground	Digital ground
DVSS	82	Ground	Digital ground
IOVSS	83	Ground	Digital I/O ground
DVSS	84	Ground	Digital ground
IOVDD	85	Supply	3.3-V digital I/O supply
DVDD	86	Supply	1.8-V digital supply
AVSS	87	Ground	Analog ground
AVDD	88	Supply	3.3-V analog supply
AVSS	89	Ground	Analog ground
DVDD1	90	Supply	1.8-V digital supply (for RTC oscillator)
RTCO	91	Output	RTC oscillator output
RTCI	92	Input	RTC oscillator input

TERMINAL FUNCTIONS (continued)

TERMINAL		FUNCTION	DESCRIPTION
NAME	NO.		
DVSS	93	Ground	Digital ground (for RTC oscillator)
AVSS	94	Ground	Analog ground
RTC_REF	95	Output	RTC output
$\overline{\text{RTC_REF}}$	96	Output	Inverted RTC output
AVDD	97	Supply	3.3-V analog supply
AVSS	98	Ground	Analog ground
AVDD	99	Supply	3.3-V analog supply
AVDD	100	Supply	3.3-V analog supply

OUTPUT DATA INTERFACE

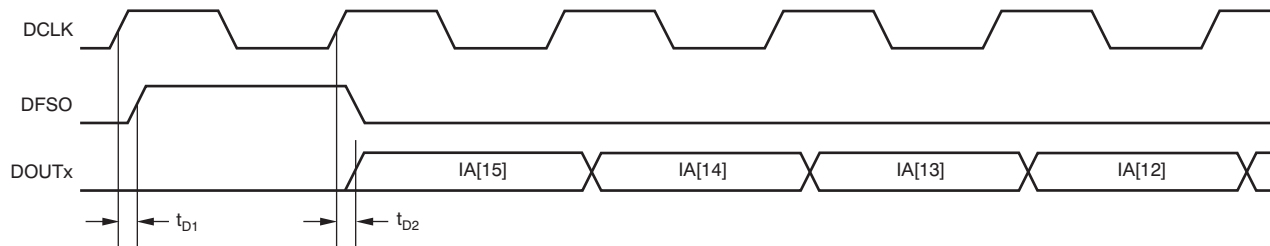

Figure 1. Output Data Interface Timing

Output Data Interface Timing

PARAMETER		TEST CONDITIONS	MIN	TYP	MAX	UNIT
t_{D1}	DCLK to DFSD delay		-2.9		3.7	ns
t_{D2}	DCLK to DOUTx delay		-3.1		3.8	ns

SPI CONTROL INTERFACE

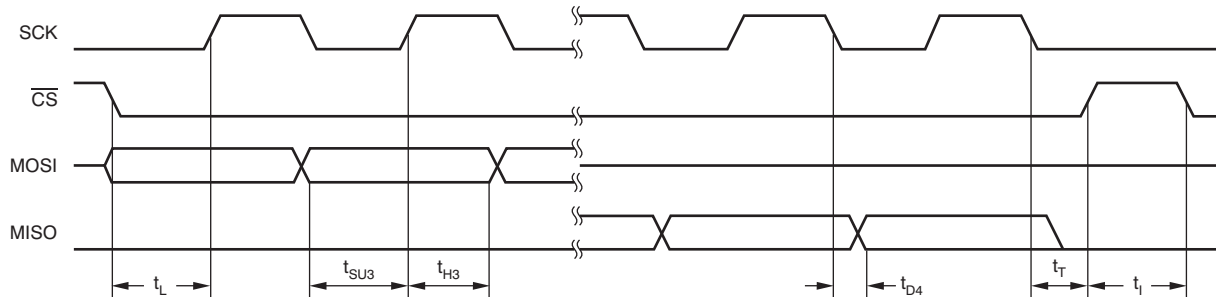

Figure 2. SPI Control Interface Timing

SPI Control Interface Timing

PARAMETER		CONDITIONS	MIN	TYP	MAX	UNIT
f_{SCK}	Maximum SCK frequency				1	MHz
t_L	\overline{CS} lead time	Trailing \overline{CS} to leading SCK	5.0			ns
t_T	\overline{CS} trail time	Trailing SCK to leading \overline{CS}	5.0			ns
t_I	\overline{CS} idle time	Leading \overline{CS} to trailing \overline{CS}	5.0			ns
t_{SU3}	MOSI to SCK setup time		5.0			ns
t_{H3}	MOSI to SCK hold time		1.0			ns
t_{D4}	SCK to MISO delay		1.0		10.4	ns

I²C BUS INTERFACE

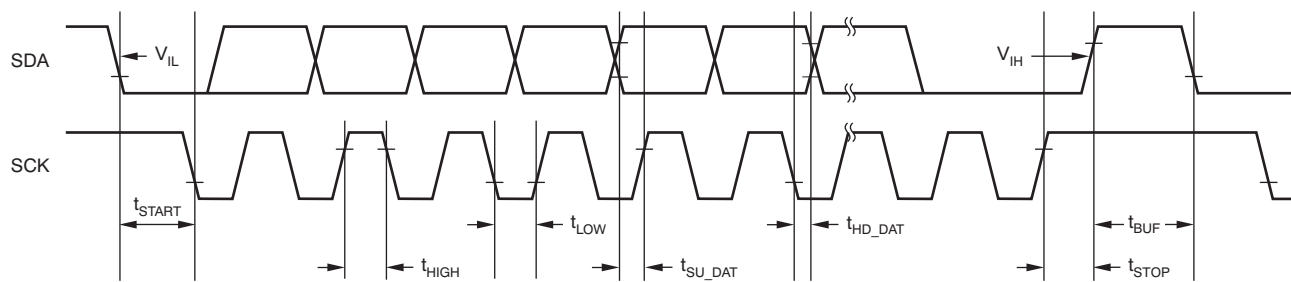

Figure 3. I²C Bus Interface Timing

I²C Bus Interface Timing

PARAMETER		MIN	TYP	MAX	UNIT
f _{SCK}	SCK clock frequency	0		400	kHz
V _{IL}	Input voltage, low			0.3 × V _{DD}	V
V _{IH}	Input voltage, high	0.7 × V _{DD}			V
t _{START}	Setup time for START or repeated START condition	0.6			μs
t _{STOP}	Setup time for STOP condition	0.6			μs
t _{LOW}	LOW period of SCK clock	1.3			μs
t _{HIGH}	HIGH period of SCK clock	0.6			μs
t _{HD_DAT}	Data hold time from SCK falling	100 ⁽¹⁾			ns
		250			
t _{SU_DAT}	Data setup time to SCK rising	100 ⁽¹⁾			ns
		250			
t _{BUF}	Bus free time between a STOP and START condition	4.7			μs

(1) Valid when MCLK > 20 MHz; otherwise is 250 ns.

DETAILED DESCRIPTION

Reset Pins

The AFE8220 has two active-low reset pins, $\overline{\text{GRST}}$ and $\overline{\text{RST}}$. When $\overline{\text{GRST}}$ is brought low, all registers on the chip are brought to default values (0, unless otherwise specified). When $\overline{\text{RST}}$ is brought low, all registers are brought to default values except for:

- Real-time clock registers (counters and alarms)
- Registers to configure the WAKEUP interrupt
- Registers controlling the GPIO pins

These registers are left in the previously programmed states.

Analog Supply Connections

A clean 3.3-V analog supply should be connected to all AVDD pins (26–27, 29, 38, 88, 97, and 99–100). Limited decoupling is required on the AVDD pins; a 0.1-mF capacitor near pins 29 and 38 and another capacitor near pins 88 and 97 should suffice.

The AFE8220 contains an internal analog switch that is used to disconnect power from the major analog blocks when the PWD pin is high. When the PWD pin is low, the AVDD1 pins (1, 5, 6, 15, 16, and 25) are internally connected to the AVDD pins (26, 27, 99, and 100). Because the AVDD1 pins are actually the active supply pins for the IF ADC and other analog components, the AVDD1 pins should be heavily bypassed with a minimum of parallel 0.1- μF and 0.01- μF ceramic capacitors at each pin (or pin pair).

Digital Supply Connections

The digital supply connections depend on whether the onboard regulators are used to generate the 1.8-V digital core voltage ($\overline{\text{REG_ENB}}$ low); or if the digital core voltage comes from a system-level supply ($\overline{\text{REG_ENB}}$ high). In either case, all IOVDD pins should be connected to the 3.3-V IO supply and appropriately bypassed. If the internal regulators are used, this supply also sources the current drawn by the digital core.

External 1.8-V Core Supply

If an external 1.8-V supply is used, all DVDD pins should be connected to the 1.8-V supply and appropriately bypassed with 0.1- μF and 0.01- μF capacitors. DVDD1 and DVDD2 pins may also be connected directly to the 1.8-V supply or may be optionally connected through a small (1 Ω to 10 Ω) series resistor to reduce supply noise coupling into the MCLK oscillator (powered through DVDD1) or the RTC oscillator (powered through DVDD2).

When using an external supply, the PWD pin disables the MCLK oscillator when high, shutting off the clock to most of the digital core. As long as the external 1.8-V supply is maintained, all register settings in the digital core are maintained with PWD is high.

Internal 1.8-V Regulator

If the internal 1.8-V regulator is used, then 0.1- μF and 0.01- μF decoupling capacitors should still be put at the DVDD, DVDD1, and DVDD2 pins. DVDD2 should still be connected to the DVDD pins either directly or through a small series resistor. DVDD1 must be isolated from DVDD and DVDD2.

While using the internal regulators, the MCLK oscillator and the internal regulators are disabled when the PWD pin is high. This condition causes most of the register settings to be lost, except for the registers associated with the real-time clock, GPIO, and WAKEUP interrupt. For this reason, the $\overline{\text{RST}}$ pin should be brought low prior to bringing the PWD pin low (to come out of power-down). The $\overline{\text{RST}}$ pin should be held low for at least 10 ms after PWD goes low to allow the internal regulators to stabilize.

Note that the internal regulators are linear regulators, and therefore are relatively inefficient. Power dissipation as a result of the digital core almost doubles when the internal regulators are used (same core current, but drawn from a 3.3-V supply instead of a 1.8-V supply). Whenever possible, the use of a more efficient external switching regulator is encouraged in order to minimize overall system power as well as to reduce the thermal stress on the AFE8220.

Control Interface

Configuration and control data are written to the AFE8220 via the control interface. The control interface supports two protocols, SPI and I²C. If the CTRL_MODE pin is tied low, then an SPI interface is implemented. If CTRL_MODE is tied high, then an I²C protocol-compatible interface is implemented.

SPI Interface

The SPI interface consists of four signals: a serial clock (SCK), an active-low chip select (\overline{CS}), a serial data input (MOSI: master out, slave in), and a serial data output (MISO: master in, slave out). Data are transferred in groups of 32 bits. The first 16 bits are the instruction, which indicates:

1. If data are to be written or to be read;
2. If the data target is a register or RAM; and
3. The address of the data target.

The second 16 bits are the data transfer, which is input on MOSI for a write cycle or output on MISO for a read cycle.

Figure 4 shows an SPI write cycle. The cycle is initiated by the high-to-low transition of the \overline{CS} line. 32 SCK pulses clock the instruction and the data into the MOSI line. Data are clocked in MSB first. The first 16 bits are the instruction. There are two possible write cycle instructions: register write and memory write. The formats for these instructions are shown in Figure 5 and Figure 6, respectively.

The only information required for a register write is the five-bit register address (REG_ADDR). For a memory write, both the two-bit memory select (MEM) plus the eight-bit memory address (MEM_ADDR) are required.

Following the 16-bit instruction, the 16-bit data word is clocked in, again MSB first. At the end of the write cycle, this data word is written to the appropriate register or memory location in the AFE8220.

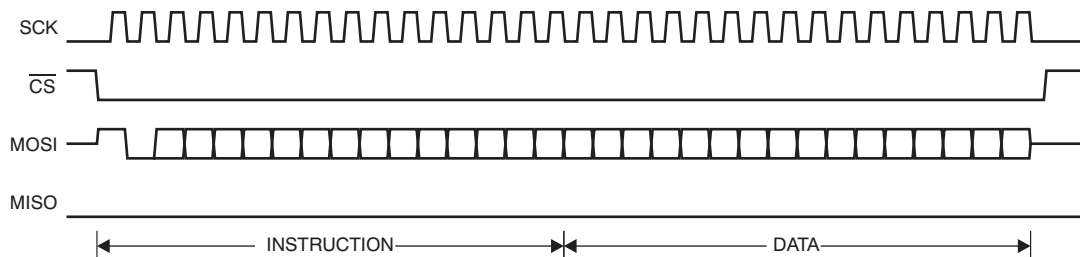

Figure 4. SPI Control Interface Write Cycle

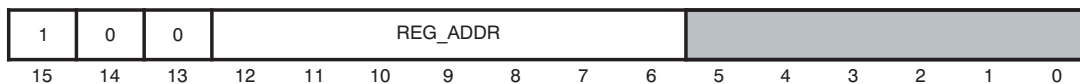

Figure 5. Register Write Instruction Format

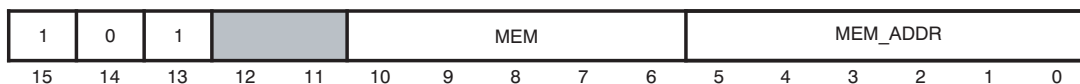

Figure 6. Memory Write Instruction Format

Figure 7 shows the SPI interface read cycle. It is similar to the write cycle, except that instead of the data word being clocked into MOSI during the second half of the cycle, the data word is clocked out of MISO. Note that only register reads are permitted; RAM reads cannot be read back.

For reading and writing, data block transfers are supported. For a block transfer, multiple data words are transmitted following the memory read or write instruction. The data words are read from or written sequentially starting at the address contained in the instruction. The sequential access terminates when the \overline{CS} line goes high. Figure 8 shows a register block read cycle. In the illustration, three succeeding register locations are read starting at address N. The block write cycle is similar except, of course, data are clocked into MOSI.

In all cases, the control interface is reset when $\overline{\text{CS}}$ goes high. If the final SCK is not received before $\overline{\text{CS}}$ goes high, then the cycle ends prematurely. For a read cycle, data transfer terminates; for a write cycle, no data are written to either a register or to memory.

I²C Slave Interface

The AFE8220 control interface can be configured to provide I²C slave operation. It has a 10-bit slave address of *00010010AB* and complies with the Philips I²C [specification](#). Note that address bits A and B are determined by the state of the I²C address pins A1 and A0. The mapping of SPI pins to I²C pins is shown in [Table 1](#).

Table 1. SPI/I²C Pin Mapping

CTRL_MODE = 0 (SPI)	CTRL_MODE = 1 (I ² C)
Chip select ($\overline{\text{CS}}$)	I ² C address bit (A1)
Master out slave in (MOSI)	I ² C address bit (A0)
Master in slave out (MISO)	Serial data line (SDA)
SPI clock (SCK)	Serial clock line (SCL)

The AFE8220 I²C interface supports both fast mode (400K bits/sec) and standard mode (100K bits/sec) operation. However, if the master crystal frequency is less than 20 MHz, then only standard mode is supported.

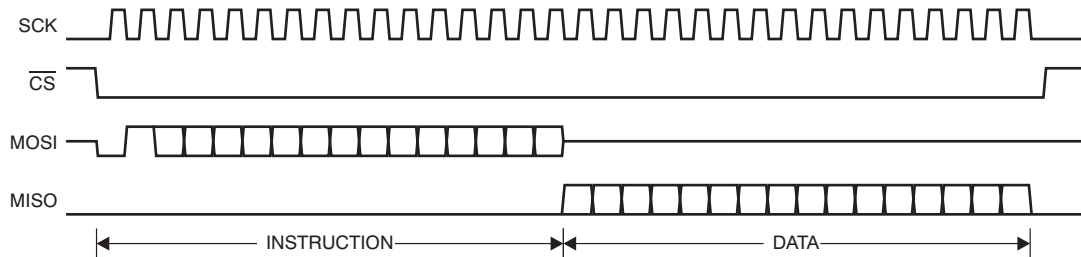

Figure 7. SPI Control Interface Read Cycle

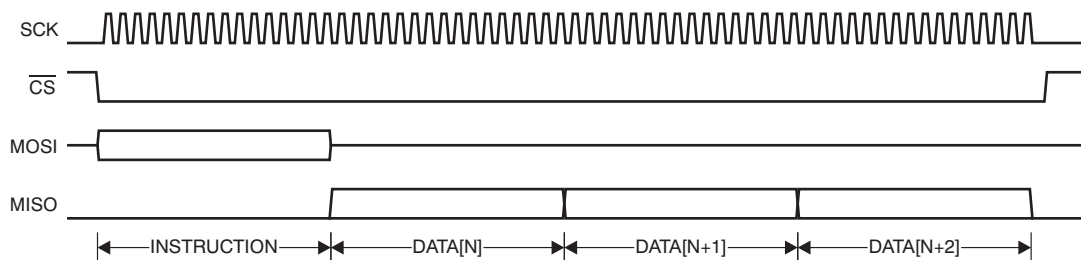

Figure 8. SPI Control Interface Block Read Cycle

As a reference, a typical data transfer on the I²C bus is described in [Figure 9](#). Each data byte is eight bits long and must be followed by an Acknowledge bit. Start and stop conditions are defined as a transition of the SDA signal with SCL high. A pulse of the SCL clock signal indicates the transfer of data or an Acknowledge bit on the SDA pin. The transmitting device drives SDA data during clock periods 1–8. The receiving device acknowledges by driving SDA low during clock 9. Master devices always generate the SCL clock and initiate transactions. Refer to the Philips I²C [Bus Specification](#) for further details.

The AFE8220 has 16-bit internal registers and operates on 16-bit instructions. Because the I²C interface is inherently an 8-bit interface, special formats are required to send instructions and data between an I²C Master and the AFE8220. The I²C [Write Operation](#) and I²C [Read Operation](#) sections describe these formats in detail.

I²C Write Operation

Write operations require a start condition followed by two bytes describing both a 10-bit address format and the AFE8220 10-bit slave address. The next two bytes must contain the 16-bit instruction word format described previously in Figure 5 or Figure 6, depending on the internal resource being addressed. Finally, a pair of bytes containing the 16-bit write data must be provided. If additional 16-bit writes are required, further pairs of bytes may be used as part of a block transfer. After the final pair of write data bytes, an I²C stop condition must be provided to terminate the transaction. Figure 11 illustrates a block write transfer of *N* 16-bit data words. Gray areas denote slave-driven SDA cycles; white areas are master-driven.

I²C Read Operation

Read operations require a start condition followed by two bytes describing both a 10-bit address format and the AFE8220 10-bit slave address. The next two bytes must contain the 16-bit instruction word format, as illustrated in Figure 10. A repeated start followed by the first byte of the slave address is then required to create a combined transaction. Note that the R/W bit is set to 1 (read), indicating that subsequent bytes are to be read from the slave. The AFE8220 presents addressed 16-bit data words in 8-bit pairs until a NACK (N) is provided by the master. After the final pair of read data bytes, an I²C stop condition must be provided to terminate the transaction. Figure 12 illustrates a block read transfer of *N* 16-bit data words. Gray areas denote slave-driven SDA cycles; white areas are master-driven.

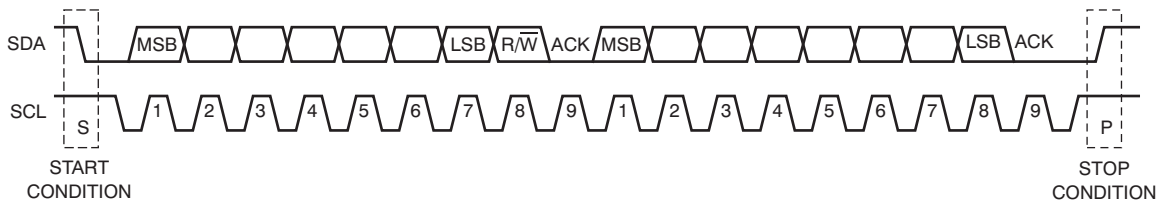

Figure 9. Example Data Transfer on the I²C Bus

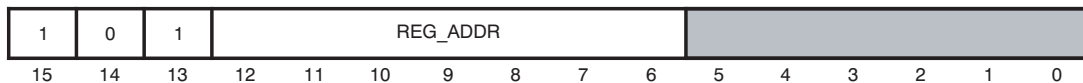

Figure 10. Register Read Instruction Format

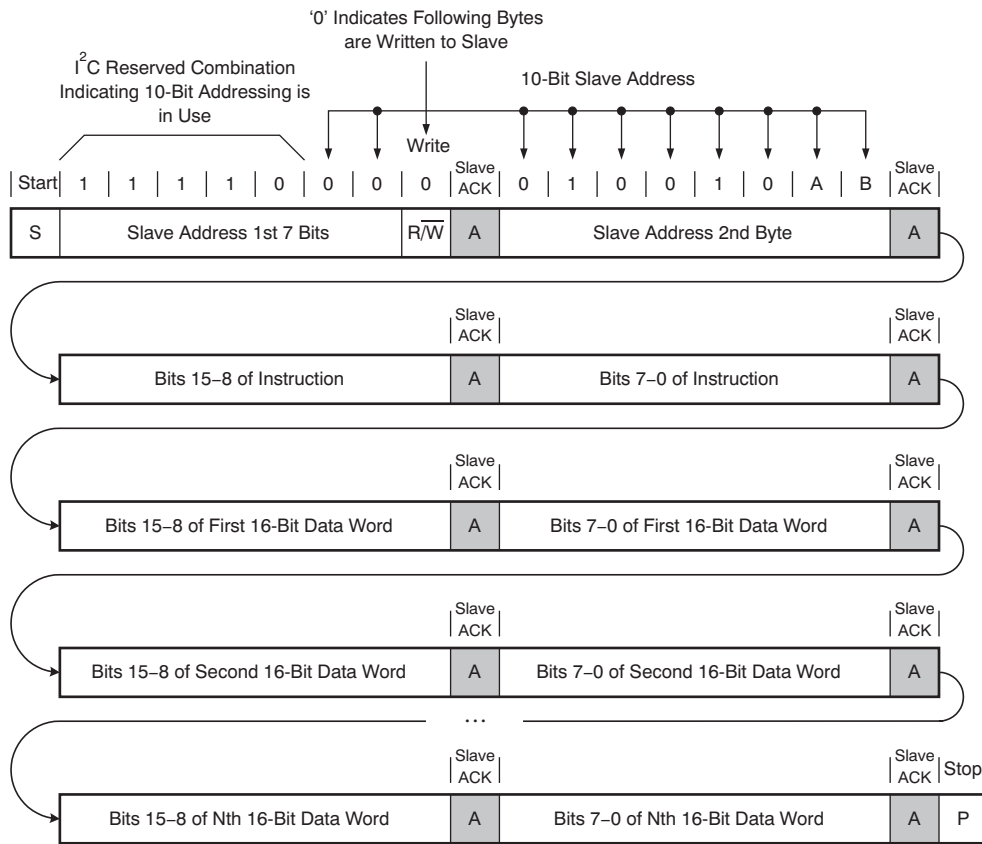

Figure 11. Example I²C Write Operation

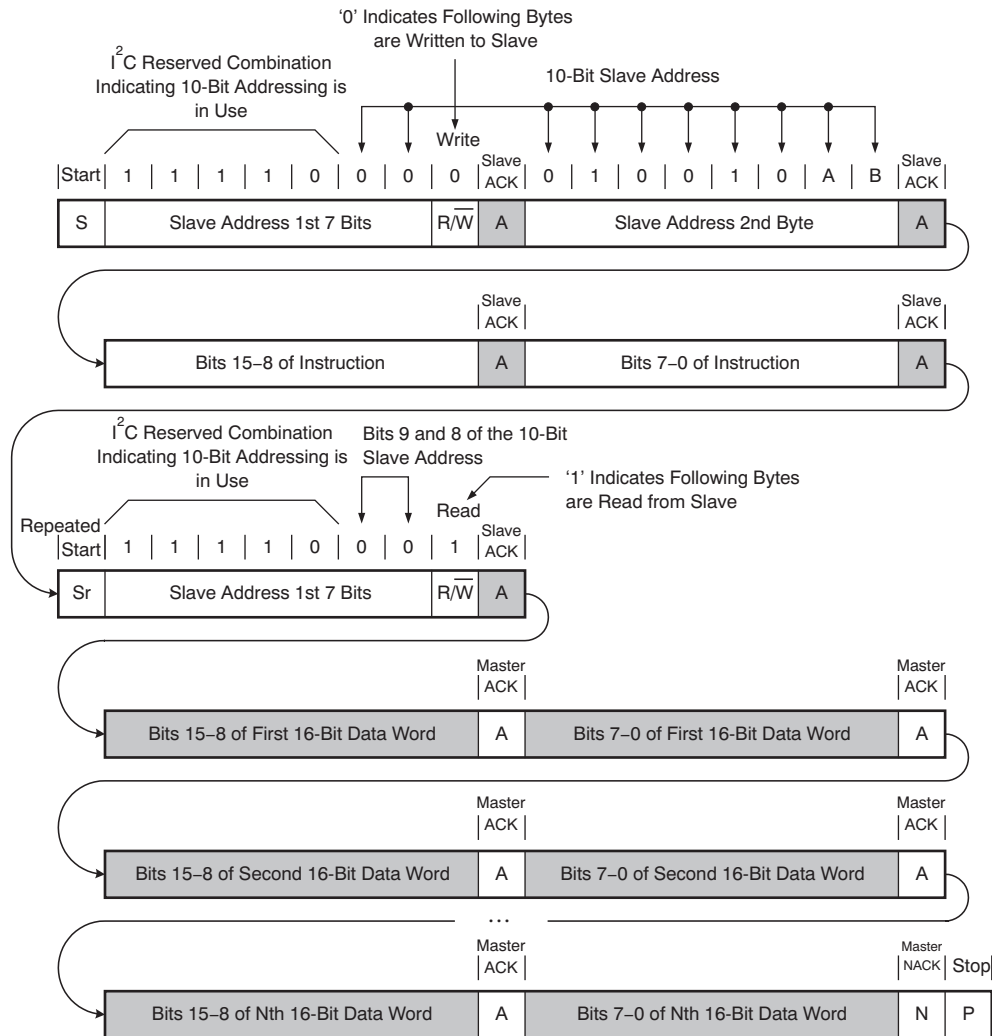

Figure 12. Example I²C Read Operation

IF ADCs (IF_ADC0 and IF_ADC1)

IF_ADC0 and IF_ADC1 are 12-bit pipeline ADCs that are used to sample the output of the tuner(s). Figure 13 shows recommended connections for the IF ADCs.

The IF ADCs have three power modes controlled by *ifadc_en[0]* and *ifadc_en[1]*. Full-power mode occurs when both *ifadc_en[0]* and *ifadc_en[1]* are high. In this case, both ADCs are biased to the highest levels and are ready to operate. If only *ifadc_en[0]* or *ifadc_en[1]* is high, then the converters are operating in reduced-power mode, where the enabled ADC is fully biased and ready to operate while the second ADC is in a low (but not zero) bias state (a minimum bias current is necessary to maintain safe voltages within the ADC core). In low-power mode, both *ifadc_en[0]* and *ifadc_en[1]* are low. In this case, all IF ADC circuits are in the minimum bias mode. Note that to reach a true sleep mode, the analog supply to the IF ADC block must be turned off.

When *ifadc_gain0* is low, IF_ADC0 is in its normal 1x gain operating state. If *ifadc_gain0* is high, then the gain of IF_ADC0 is changed to 2x. In a similar fashion, *ifadc_gain1* controls the gain of IF_ADC1. Table 2 shows the *ifadc_en* and *ifadc_gain* control variable parameters.

Table 2. IF_ADC Control Register Settings

PARAMETER	ADDRESS	BITS
ifadc_en[0]	1	0
ifadc_en[1]	1	1
ifadc_gain0	1	2
ifadc_gain1	1	3

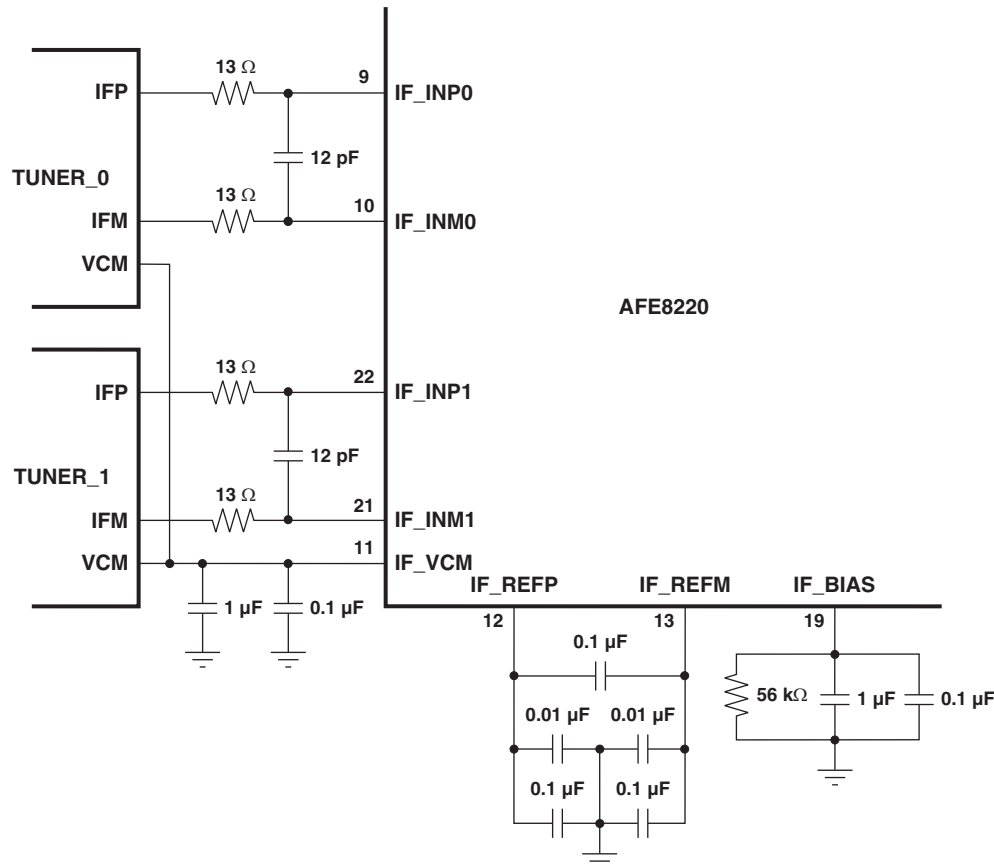
**Figure 13. IF ADC Connections**

IF ADC Alarm/Attenuator

The output of each IF ADC is monitored to ensure that the full-scale input range is not exceeded. If an ADC over-range condition occurs, an overflow signal is generated that may be used to generate an interrupt on the IRQ line, depending on the settings in the IRQ interrupt generator.

In addition, programmable limits may be set for each IF ADC. If the absolute value of IF_ADC0 exceeds *if_adc_limit0* or the absolute value of IF_ADC1 exceeds *ifadc_limit1*, then an interrupt may be generated on IRQ again depending on the settings in the IRQ interrupt generator.

In the case of an IF ADC event, the IRQ status register can be read back to determine the type of event and on which ADC channel it occurred. The IRQ status register can be polled to determine if an IF ADC event has occurred in the case where IF ADC events are masked from generating an interrupt.

The control variable *ddc0_atten* causes an attenuation of the IF_ADC0 output prior to the DDC. The attenuation ranges in 3-dB steps from 0 dB (for *ddc0_atten* = 0) to –18 dB (for *ddc0_atten* = 6). *ddc1_atten* has the same effect on the output of IF_ADC1.

In order to better synchronize the IF ADC attenuator with the tuner automatic gain control (AGC), a delay may be programmed between when a new value of *ddc_atten* is written and when it takes effect. When a new value of *ddc0_atten* is written, a counter (driven by MCLK) is initialized to *ddc0_delay*. When the counter reaches zero, the actual attenuation change occurs. Likewise, *ddc1_delay* affects *ddc1_atten*. Note that if a new *ddc0_atten* is written before the delay counter has reached zero from the previous write, the previous write is discarded. [Table 3](#) shows the attenuator, delay, and limit control variables.

Table 3. IF ADC Control Register Settings

PARAMETER	ADDRESS	BITS
<i>ddc0_atten</i>	3	2:0
<i>ddc1_atten</i>	15	2:0
<i>ddc0_delay</i>	4	15:0
<i>ddc1_delay</i>	16	15:0
<i>ifadc_limit0</i>	46	11:0
<i>ifadc_limit1</i>	47	11:0

Digital Downconverter 0 (DDC0)

DDC0 operation is controlled by *ddc_en[0]*. When *ddc_en[0]* is 1, operation of DDC0 is enabled. If *ddc_en[0]* is 0, operation of DDC0 is disabled. [Table 4](#) shows the DDC0 operation control settings.

Table 4. DDC Control Register Settings

PARAMETER	ADDRESS	BITS
<i>ddc0_cic_dec_rate</i>	9	8:0
<i>ddc0_cic_scale</i>	10	11:6
<i>ddc0_cic_shift</i>	10	5:0
<i>ddc0_demod_freq[31:16]</i>	5	15:0
<i>ddc0_demod_freq[15:0]</i>	6	15:0
<i>ddc0_demod_phase[31:16]</i>	7	15:0
<i>ddc0_demod_phase[15:0]</i>	8	15:0
<i>ddc0_fir1_base_address</i>	11	13:8
<i>ddc0_fir1_mode</i>	11	1:0
<i>ddc0_fir1_ncoeffs</i>	11	7:2
<i>ddc0_fir1_nodect</i>	14	9
<i>ddc0_fir2_nodect</i>	14	10
<i>ddc0_fir2a_base_address</i>	12	15:9
<i>ddc0_fir2a_mode</i>	12	1:0
<i>ddc0_fir2a_ncoeffs</i>	12	8:2
<i>ddc0_fir2a_shift</i>	14	3:0
<i>ddc0_fir2b_base_address</i>	13	15:9
<i>ddc0_fir2b_mode</i>	13	1:0
<i>ddc0_fir2b_ncoeffs</i>	13	8:2
<i>ddc0_fir2b_shift</i>	14	7:4
<i>ddc0_interleave</i>	14	8
<i>ddc_en[0]</i>	1	4
<i>ddc_sync</i>	1	6

Quadrature Mixer/NCO

The NCO frequency and initial phase are set by the 32-bit unsigned variables *ddc0_demod_freq* and *ddc0_demod_phase*. The I and Q outputs of the mixer can be calculated by [Equation 1](#) and [Equation 2](#).

$$I = \text{ADC} \times \cos(2\pi ft + \phi) \quad (1)$$

$$Q = \text{ADC} \times \sin(2\pi ft + \phi) \quad (2)$$

where ADC is the output of the IF analog-to-digital converter, f is the NCO phase offset (in radians) given by [Equation 3](#), and ϕ is the NCO phase offset (in radians) given by [Equation 4](#).

$$f = f_{\text{MCLK}} \frac{\text{ddc0_demod_freq}}{2^{32}} \quad (3)$$

$$\phi = 2\pi \frac{\text{ddc0_demod_phase}}{2^{32}} \quad (4)$$

The *ddc_sync* signal can be used to control the phase of the mixer. While the *ddc_sync* signal is high, the phase accumulator is held to a constant value *ddc0_demod_phase*, essentially holding it to 0 in [Equation 1](#) and [Equation 2](#). When the *ddc_sync* signal is brought low, the phase accumulator is incremented by the value *ddc0_demod_freq* once per MCLK cycle.

CIC Filter

The first stage of decimation filtering is provided by a fifth-order CIC filter. The operation of the CIC filter is controlled by the unsigned variables *ddc0_cic_dec_rate*, *ddc0_cic_scale*, and *ddc0_cic_shift*. The valid range for *ddc0_cic_dec_rate* is from 4 to 256.

The inherent dc gain of the CIC filter is *ddc0_cic_dec_rate*. The control variables *ddc0_cic_shift* and *ddc0_cic_scale* are used to reduce this very high gain before the signal is output to the next stage of the decimation filter. The combined effect of *ddc0_cic_dec_rate*, *ddc0_cic_shift*, and *ddc0_cic_scale* produces an overall dc gain for the CIC filter of [Equation 5](#).

$$\text{GAIN} = \text{ddc0_cic_dec_rate}^5 \frac{\text{ddc0_cic_scale}/32}{2^{\text{ddc0_cic_shift}}} \quad (5)$$

In general, *ddc0_cic_shift* and *ddc0_cic_scale* should be chosen to make GAIN as close to 1 as possible. For example, if *ddc0_cic_dec_rate* is 20, setting *ddc0_cic_shift* to 22 and *ddc0_cic_scale* to 41 results in a GAIN of 0.9775.

First FIR Filter

The block following the CIC filter is a decimate-by-two finite impulse response (FIR) filter with programmable coefficients. *ddc0_fir1_mode* sets the type of filter response—ODD (MODE = 00: symmetric impulse response, odd number of taps), EVEN (MODE = 01: symmetric impulse response, even number of taps), HALFBAND (MODE = 10), and ARBITRARY (MODE = 11: non-symmetric impulse response).

The 16-bit wide filter coefficients are stored in memory bank 0. Up to 64 coefficients can be stored in this memory. Depending on the types of filters desired and the number of taps, coefficients for multiple filter responses may be stored in the memory bank. The filter response may be changed simply by updating the control register with new values for *ddc0_fir1_mode*, *ddc0_fir1_ncoeff*, and *ddc0_fir1_base_addr*.

ddc0_fir1_ncoeff defines the number of unique filter coefficients that make up the filter response. *ddc0_fir1_base_addr* defines the memory location where the first filter coefficient is stored. The actual filter length is a function of the *ddc0_fir1_mode* and *ddc0_fir1_ncoeff*, as shown in [Equation 6](#).

$$\begin{aligned}
 \text{Filter Length} &= 2 \times (\text{ddc0_fir1_ncoeff} - 1) + 1 \text{ for ODD} \\
 \text{Filter Length} &= 2 \times \text{ddc0_fir1_ncoeff} \text{ for EVEN} \\
 \text{Filter Length} &= 4 \times (\text{ddc0_fir1_ncoeff} - 1) + 1 \text{ for HALFBAND} \\
 \text{Filter Length} &= \text{ddc0_fir1_ncoeff} \text{ for ARBITRARY}
 \end{aligned} \tag{6}$$

The maximum filter length that can be realized is limited by two factors. First, the number of clock cycles between successive filter outputs limits the number of coefficients that can be processed, as shown in [Equation 7](#).

$$\text{ddc0_fir1_ncoeff} \leq 2 \times \text{ddc0_cic_dec_rate} \tag{7}$$

where *ddc0_cic_dec_rate* is the decimation ration of the CIC filter.

Second, the size of the data memory (which stores incoming data samples) limits filter length to 62 taps.

The dc gain of the FIR filter depends on the coefficient values and the filter mode. For ODD mode and HALFBAND mode, the dc gain is given by [Equation 8](#):

$$\text{GAIN} = \left(\frac{h_{\text{NCOEFF}} + \sum_{n=1}^{\text{NCOEFF}-1} 2h_n}{2^{15} - 1} \right) \tag{8}$$

where h_n is the n^{th} of NCOEFF filter coefficients stored in memory.

For EVEN mode the, dc gain is shown by [Equation 9](#):

$$\text{GAIN} = \left(\frac{\sum_{n=1}^{\text{NCOEFF}} 2h_n}{2^{15} - 1} \right) \tag{9}$$

while for ARBITRARY mode the gain is shown by [Equation 10](#):

$$\text{GAIN} = \left(\frac{\sum_{n=1}^{\text{NCOEFF}} h_n}{2^{15} - 1} \right) \tag{10}$$

Second FIR Filters

The first FIR filter is followed by two parallel second FIR filters, FIR2A and FIR2B. Duplicate filters allow the output of two I and Q output streams with different bandwidths. For example, the bandwidth of FIR2A may be set wide to accommodate reception of digital broadcasts, while FIR2B may be set narrower to receive an analog broadcast sharing the same band. Coefficients for FIR2A are stored in memory bank 1 (MEM = 1) and coefficients for FIR2B are stored in memory bank 2 (MEM = 2).

The operation of the second FIR filter is similar to the first FIR filter with several notable exceptions. First, the depths of the coefficient and data memories are doubled to 128. This size increase allows for filters up to 126 taps to be realized without running out of data memory. It also allows longer sets of filter coefficients to be stored in coefficient memory.

Second, because of the additional decimation by two from the first FIR filter, twice as many MCLK cycles are available to process coefficients, increasing the maximum allowable value of NCOEFF, as shown in [Equation 11](#) and [Equation 12](#).

$$\text{ddc0_fir2a_ncoeff} \leq 4 \times \text{ddc0_cic_dec_rate} \tag{11}$$

$$\text{ddc0_fir2b_ncoeff} \leq 4 \times \text{ddc0_cic_dec_rate} \tag{12}$$

Third, in the first FIR filter the total of all the filter tap weights must add up to $(2^{15} - 1)$ to achieve unity gain through the filter. With longer filters (and therefore, smaller coefficients), frequency response errors may be introduced as a result of coefficient truncation. A Shift parameter has been added to the second FIR filter to alleviate this problem. The total of all filter tap weights must add up to $(2^{15+\text{ddc0_fir2a_shift}} - 1)$ to achieve unity gain through FIR2A (similarly for *ddc0_fir2b_shift* and FIR2B). Note that shift values for FIR2A and FIR2B can be set separately.

Extended-Length Filter Mode

If FIR2A or FIR2B cannot provide enough filter taps to achieve the desired frequency response, setting control bit *ddc0_interleave* puts the two filters into an interleaved mode that doubles the length of the filter that can be realized. However, there are several limitations:

1. Only odd symmetrical filters may be realized;
2. The filter length M must be such that $(M + 1)/4$ is an integer; and
3. Only one filter can be realized (in *ddc0_interleave* mode the A and B outputs are identical: $IB = IA$ and $QB = QA$).

In addition to setting the *ddc0_interleave* bit, FIR2A must be set to EVEN mode and FIR2B must be set to ODD mode. *ddc0_fir2a_ncoeff* and *ddc0_fir2b_ncoeff* are both set to $(M + 1)/4$. *ddc0_fir2a_shift* and *ddc0_fir2b_shift* should be identical. There are no restrictions on *ddc0_fir2a_base_addr* or *ddc0_fir2b_base_addr*.

The M-tap filter has $(M + 1)/2$ unique coefficients. The first, third, fifth, etc. coefficients are loaded into the FIR2A coefficient memory; the second, fourth, sixth, etc. coefficients are loaded into the FIR2B memory. The center coefficients of the filter end up as the last coefficient loaded into FIR2B.

FIR Filter Transfer Functions

Equation 13 to Equation 21 show transfer functions and dc gain for the various filter modes. Generic names for the control variables are used; just substitute the appropriate variable (that is, *ddc0_fir2a_ncoeff* for NCOEFF) as necessary. Also, note that SHIFT has a value of 0 for FIR1.

Basic Filter Modes

$$H_{\text{EVEN}}(z) = \sum_{n=0}^{\text{NCOEFF}-1} \text{COEFF}_{\text{BASE_ADDR}+n} \times (z^{-n} + z^{-(2 \times \text{NCOEFF} - 1 - n)}) \quad (13)$$

$$H_{\text{ODD}}(z) = \sum_{n=0}^{\text{NCOEFF}-2} \text{COEFF}_{\text{BASE_ADDR}+n} \times (z^{-n} + z^{-(2 \times \text{NCOEFF} - 2 - n)}) + \text{COEFF}_{\text{BASE_ADDR}+\text{NCOEFF}-1} \times z^{\text{NCOEFF}-1} \quad (14)$$

$$H_{\text{HALFBAND}}(z) = \sum_{n=0}^{\text{NCOEFF}-2} \text{COEFF}_{\text{BASE_ADDR}+n} \times (z^{-2n} + z^{-(4 \times \text{NCOEFF} - 6 - 2n)}) + \text{COEFF}_{\text{BASE_ADDR}+\text{NCOEFF}-1} \times z^{2 \times \text{NCOEFF} - 3} \quad (15)$$

$$H_{\text{ARBITRARY}}(z) = \sum_{n=0}^{\text{NCOEFF}-1} \text{COEFF}_{\text{BASE_ADDR}+n} \times z^{-n} \quad (16)$$

$$\text{GAIN}_{\text{EVEN}}(z) = 2^{-\text{SHIFT}} \times \frac{2 \times \sum_{n=0}^{\text{NCOEFF}-1} \text{COEFF}_{\text{BASE_ADDR}+n}}{2^{15} - 1} \quad (17)$$

$$\text{GAIN}_{\text{ODD}} = \text{GAIN}_{\text{HALFBAND}} = 2^{-\text{SHIFT}} \times \frac{2 \times \sum_{n=0}^{\text{NCOEFF}-2} \text{COEFF}_{\text{BASE_ADDR}+n} + \text{COEFF}_{\text{BASE_ADDR}+\text{NCOEFF}-1}}{2^{15} - 1} \quad (18)$$

$$\text{GAIN}_{\text{ARBITRARY}}(z) = 2^{-\text{SHIFT}} \times \frac{\sum_{n=0}^{\text{NCOEFF}-1} \text{COEFF}_{\text{BASE_ADDR}+n}}{2^{15} - 1} \quad (19)$$

Extended-Length Filter Mode

$$H_{\text{EXTENDED}}(z) = 2^{-\text{SHIFT}} \times \left(\begin{aligned} &\sum_{n=0}^{\text{NCOEFF}-1} \text{COEFF_A}_{\text{BASE_ADDR_A}+n} \times (z^{-2 \times n} + z^{-2 \times (2 \times \text{NCOEFF}-1-n)}) \\ &+ \sum_{n=0}^{\text{NCOEFF}-2} \text{COEFF_B}_{\text{BASE_ADDR_B}+n} \times (z^{-2 \times n+1} + z^{-2 \times (2 \times \text{NCOEFF}-2-n)+1}) \\ &+ \text{COEFF_B}_{\text{BASE_ADDR_B}+\text{NCOEFF}-1} \times z^{2 \times \text{NCOEFF}} \end{aligned} \right) \quad (20)$$

$$\text{GAIN}_{\text{EXTENDED}} = \frac{2^{-\text{SHIFT}}}{2^{15}-1} \times \left(\begin{aligned} &2 \times \sum_{n=0}^{\text{NCOEFF}-1} \text{COEFF_A}_{\text{BASE_ADDR_A}+n} \\ &+ 2 \times \sum_{n=0}^{\text{NCOEFF}-2} \text{COEFF_B}_{\text{BASE_ADDR_B}+n} \\ &+ \text{COEFF_B}_{\text{BASE_ADDR_B}+\text{NCOEFF}-1} \end{aligned} \right) \quad (21)$$

Digital Downconverter 1 (DDC1)

The description of DDC1 is identical to the description of DDC0, with the following exceptions:

1. DDC1 is enabled by *ddc_en[1]*.
2. Control variables are prefixed with *ddc1* instead of *ddc0*.
3. FIR coefficients are stored in memory banks 3, 4, and 5 instead of 0, 1, and 2.

Table 5 shows the DDC1 operation control settings.

IF Data Interface

The two DDCs produce a total of eight 16-bit output values (I and Q from each of four final-stage FIR filters). The IF data interface time-multiplexes these eight values onto four serial lines. The IF data interface also generates the necessary clock and frame sync signals to complete the interface to the DSP. The general timing of the IF data interface is shown in Figure 14.

Note that each serial line (IF_DOUT0 through IF_DOUT3) can carry up to four time-multiplexed 16-bit signals. The actual number of signals per line is limited by:

- a. the frequency of IF_DCLK, which can be programmed to be the same as the IF sampling clock (MCLK), one-half the IF sampling frequency, or one-fourth the IF sampling frequency; and
- b. the overall decimation ratio of the DDC that determines the frequency of IF_DFSSO pulses and therefore the number of IF_DCLK cycles available to clock out data.

Table 5. IF Control Register Settings

PARAMETER	ADDRESS	BITS
ddc1_cic_dec_rate	21	8:0
ddc1_cic_scale	22	11:6
ddc1_cic_shift	22	5:0
ddc1_demod_freq[31:16]	17	15:0
ddc1_demod_freq[15:0]	18	15:0
ddc1_demod_phase[31:16]	19	15:0
ddc1_demod_phase[15:0]	20	15:0
ddc1_fir1_base_address	23	13:8
ddc1_fir1_mode	23	1:0
ddc1_fir1_ncoeffs	23	7:2
ddc1_fir1_noddec	26	9
ddc1_fir2_noddec	26	10
ddc1_fir2a_base_address	24	15:9
ddc1_fir2a_mode	24	1:0
ddc1_fir2a_ncoeffs	24	8:2

Table 5. IF Control Register Settings (continued)

PARAMETER	ADDRESS	BITS
ddc1_fir2a_shift	26	3:0
ddc1_fir2b_base_address	25	15:9
ddc1_fir2b_mode	25	1:0
ddc1_fir2b_ncoeffs	25	8:2
ddc1_fir2b_shift	26	7:4
ddc1_interleave	26	8
ddc_en[1]	1	5
ddc_sync	1	6

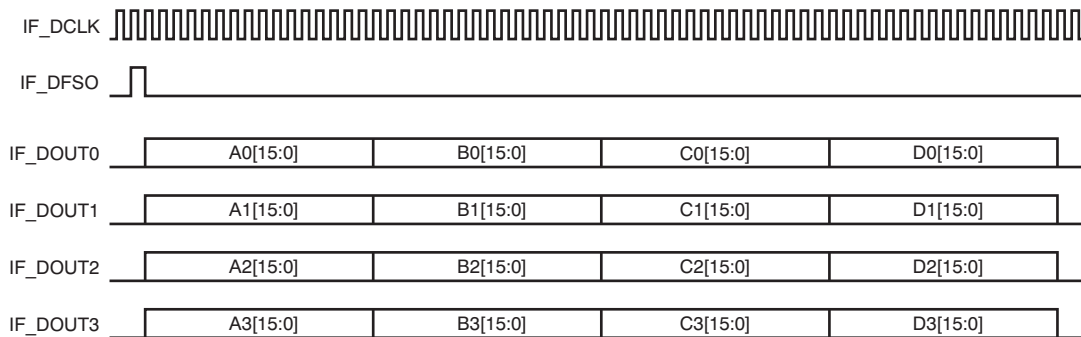

Figure 14. IF Data General Timing

Control register variables *dout0_config*, *dout1_config*, *dout2_config*, and *dout3_config*, are used to assign specific output data streams to particular time slots in the IF interface output frame. Each register is broken into four 4-bit values, each of which is used to assign the source for a given time slot according to [Table 6](#).

Table 6. Time Slot Sources

VALUE	SOURCE
0	No source assigned
1	DDC0, FIR2A, I
2	DDC0, FIR2A, Q
3	DDC0, FIR2B, I
4	DDC0, FIR2B, Q
5	DDC1, FIR2A, I
6	DDC1, FIR2A, Q
7	DDC1, FIR2B, I
8	DDC1, FIR2B, Q

dout0_config controls the four time slots of IF_DOUT0, register 24 controls the four time slots of IF_DOUT1, and so on. The mapping of register bits to time slots is summarized in [Table 7](#).

Table 7. Register Bit Mapping

PARAMETER	[15:12]	[11:8]	[7:4]	[3:0]
dout0_config	D0	C0	B0	A0
dout1_config	D1	C1	B1	A1
dout2_config	D2	C2	B2	A2
dout3_config	D3	C3	B3	A3

For example, bits [11:8] of *dout2_config* set the source assignment for time slot C2 of IF_DOUT2.

The control variable *if_dclk_div* sets the frequency of IF_DCLK, as shown in Equation 22 and Equation 23.

$$f_{IF_DCLK} = \frac{f_{MCLK}}{if_dclk_div} \quad if_dclk_div > 1 \tag{22}$$

$$f_{IF_DCLK} = f_{MCLK} \quad if_dclk_div \leq 1 \tag{23}$$

Normally the data and the frame sync change on the rising edge of IF_DCLK. If *if_dclk_edge* is set to 1 then IF_DCLK is inverted so that data and frame sync change on the falling edge of IF_DCLK.

The control value *if_dfso_select* determines which DDC is responsible for generating IF_DFSD. If *if_dfso_select* is 0, then an IF_DFSD pulse is generated each time a new output is ready from DDC0. Similarly, if *if_dfso_select* is 1, then an IF_DFSD pulse is generated each time a new output is ready from DDC1. If the decimation rates of DDC0 and DDC1 are identical, then it does not matter which DDC initiates the IF_DFSD pulse. If the decimation rates are different, then the DDC with the smaller decimation ratio (higher output rate) should be chosen to generate the IF_DFSD pulse. Note that in this case, outputs from the slower DDC are repeated for multiple frames and it is the responsibility of the DSP software to compensate. This compensation is easiest to do if the higher decimation rate is an integer multiple of the lower decimation rate.

Finally, *if_dfso_mode* is used to select alternate forms of frame sync. In the default case (*if_dfso_mode* = 0), the frame sync is a high pulse one clock period wide that occurs the clock cycle before the first data bit of the serial output. If *if_dfso_mode* is set to 1, then the frame sync changes polarity once per frame; again, one clock cycle before the first data bit of the frame. If *if_dfso_mode* is set to 2, then the frame sync behaves like the default frame sync except that the sync pulse is 16 clock periods wide. The three frame sync modes are illustrated in Figure 15 and Figure 16. Table 8 shows the detailed timing conditions for Figure 16.

It is recommended that the DSP interface be configured to sample IF_DFSD and the four IF_DOUT lines on the trailing edge of IF_DCLK. Table 9 shows the *dout*, *if_dclk*, *if_dfso*, and *if_dout* operation control settings.

Table 8. Detailed Timing Conditions

PARAMETER		MIN	TYP	MAX	UNIT
t _{D1}	IF_DCLK0 to IF_DFSD delay	-2.9		3.7	ns
t _{D2}	IF_DCLK0 to IF_DOUTx delay	-3.1		3.8	ns

Table 9. Primary IF Control Register Settings

PARAMETER	ADDRESS	BITS
<i>dout_en</i>	1	7
<i>if_dclk_div</i>	31	4:0
<i>if_dclk_edge</i>	31	5
<i>if_dfso_mode</i>	31	8:7
<i>if_dfso_select</i>	31	6
<i>if_dout0_config</i>	27	15:0
<i>if_dout1_config</i>	28	15:0
<i>if_dout2_config</i>	29	15:0
<i>if_dout3_config</i>	30	15:0

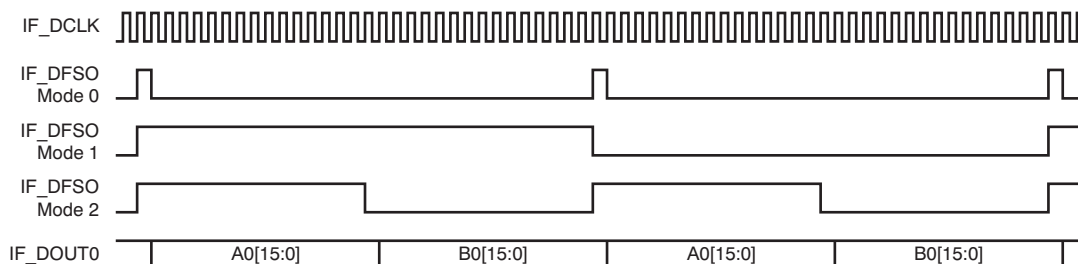

Figure 15. Frame Sync Modes

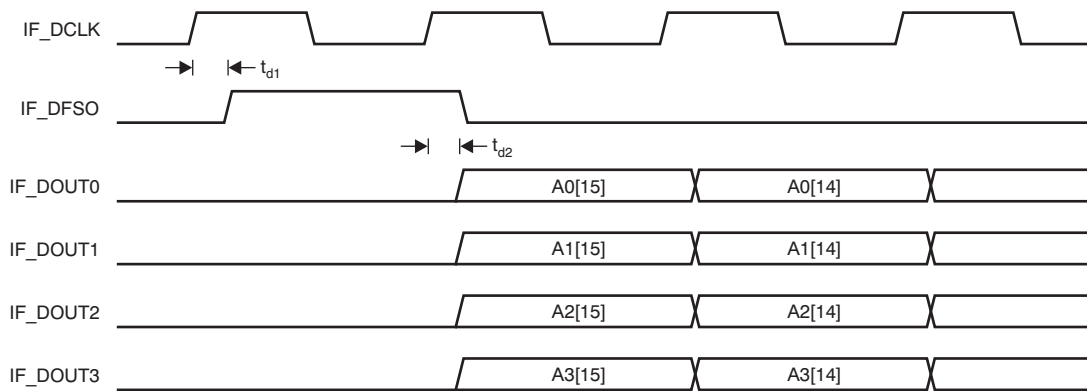

Figure 16. Detailed Timing

Auxiliary DACS

CDAC0 is enabled by a high value set for *cdac_en[0]*. Similarly, CDAC1 is enabled by a high value set for *cdac_en[1]*. A control DAC that is disabled is put into a low-power state.

The control DAC outputs are set by the control variable *cdac0_out* for CDAC0 and *CDAC1_OUT* for CDAC1. A value of zero generates a 0 output from the control DAC while a value of 4095 generates a full-scale output from the control DAC. [Table 10](#) shows the CDAC operation control settings.

Table 10. CDAC Control Register Settings

PARAMETER	ADDRESS	BITS
<i>cdac_en[0]</i>	1	9
<i>cdac_en[1]</i>	1	10
<i>cdac0_out</i>	37	11:0
<i>cdac1_out</i>	38	11:0

Master Clock Oscillator

The master clock oscillator supports third-overtone designs from 55 MHz to 75 MHz. It can also support fundamental operations in the 20-MHz to 30-MHz range. The recommended third-overtone circuit for third-overtone operation is shown in Figure 17 and Table 11.

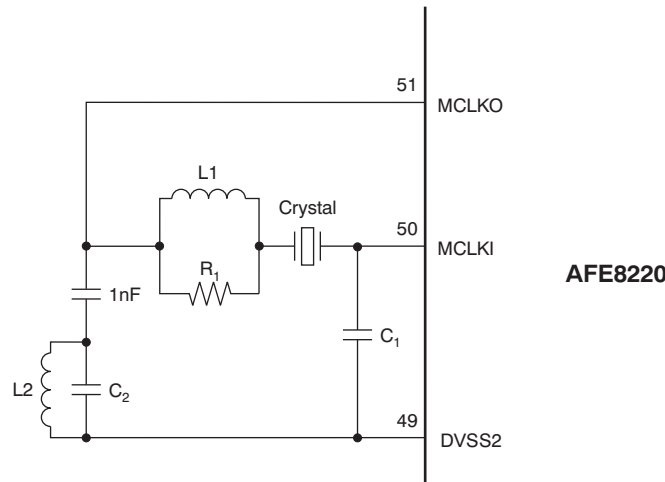

Figure 17. Third-Overtone Operation

Table 11. Third-Overtone Operation Recommendations

FREQUENCY (MHz)	C ₁ (pF)	C ₂ (pF)	L1 (μH)	L2 (μH)	R ₁ (kΩ)
55	3	10	0.1	4.7	6.8
60	5	10	0.82	3.3	4.7
65	4	10	0.68	2.7	3.3
70	5	10	0.56	2.7	3.3
75	3	10	0.56	2.2	3.3

The master clock oscillator may be optionally divided down to provide a reference clock on the REFCLK pin. Control variable *refclk_en* enables the generation of the reference clock when high. Two variables, *refclk_hi* and *refclk_lo*, define the high and low periods of REFCLK in terms of MCLK cycles. REFCLK is high for *refclk_hi* cycles of MCLK, then low for *refclk_lo* periods of MCLK. REFCLK frequency is limited to integer submultiples of MCLK. Table 12 shows the *refclk* operation control settings.

Table 12. REFCLK Control Register Settings

PARAMETER	ADDRESS	BITS
<i>refclk_en</i>	1	13
<i>refclk_hi</i>	41	15:0
<i>refclk_lo</i>	40	15:0

Real-Time Clock Oscillator

The real-time clock oscillator supports crystals in the frequency range of 32.768 kHz through 150 kHz. The real-time clock module can be programmed to operate accurately with crystals in this frequency range.

The real-time clock oscillator output may be optionally output on the RTC_OUT pin when *rtc_oe* is set high. This option allows the real-time clock oscillator to be used as an alternate reference clock in the event that an acceptable frequency cannot be derived from MCLK. Table 13 shows the *rtc_oe* control setting.

Table 13. RTC Control Register Setting

PARAMETER	ADDRESS	BITS
<i>rtc_oe</i>	1	12

Real-Time Clock

The real-time clock (RTC) is enabled by setting *rtc_en* to 1. While *rtc_en* is 0, the RTC oscillator continues to run but the RTC registers do not advance.

The RTC can operate with a range of oscillator frequencies up to 100 kHz. At the beginning of each second, two times the value of *rtc_max_count* is loaded into the RTC crystal counter. This counter is decremented at the rate of the RTC oscillator until it hits zero, which generates a strobe that increments the seconds counter as well as re-initializes the RTC crystal counter. For a nominal 32.768-kHz clock crystal, *rtc_max_count* should be set to 16,384 (the default value); for a nominal 100-kHz crystal, *rtc_max_count* should be set to 50,000. [Table 15](#) illustrates the RTC control variable settings.

The RTC can be coarsely calibrated by adjusting the *rtc_max_count* to an appropriate value other than half the nominal crystal frequency. If finer calibration is required, compensation mode can be enabled by setting *rtc_comp_en* to 1. In compensation mode, the two's-complement value stored in *rtc_comp_val* is added to the one-second counter when it is re-initialized at the beginning of each hour; thus, the first second of each hour is lengthened or shortened depending on the sign of *rtc_comp_val*. The compensation can be applied to several seconds at the beginning of each hour; *rtc_comp_cnt* holds the number of seconds per hour to which the compensation is applied. By spreading the compensation out over a number of seconds, the impact on the length of any given second is minimized.

Setting and Reading the RTC

Because of the need to carefully synchronize any update of the RTC time registers (*rtc_seconds*, *rtc_minutes*, etc.), they must be written in a slightly different manner than the other control registers. Time registers must be written individually; after a particular register address is written, at least two clock cycles of the RTC oscillator must pass before another register write occurs. The MSB of each time register address can be polled to determine if it is safe to make another write: if the MSB is 1, the interface is still busy and a new write should not be initiated. If the MSB is 0, then the interface is ready to accept another write. There is no limitation on reading the time registers.

Note that all time register values are BCD-encoded. Also note that the *rtc_day_of_week* is a read-only value that is internally calculated from the *rtc_day*, *rtc_month*, and *rtc_year* registers. Ranges on the various time registers are shown in [Table 14](#).

Table 14. Time Register Ranges

PARAMETER	RANGE
<i>rtc_seconds</i>	0 to 59
<i>rtc_minutes</i>	0 to 59
<i>rtc_hours</i>	0 to 12 (12-hour mode); 0 to 24 (24-hour mode)
<i>rtc_ampm</i>	0 (AM) or 1 (PM) 12-hour mode only
<i>rtc_day</i>	1 to 31
<i>rtc_month</i>	1 to 12
<i>rtc_year</i>	0 to 99 (for years 2000 to 2099)
<i>rtc_day_of_week</i>	0 (Sunday) to 6 (Saturday)

Invalid combinations of *rtc_day* and *rtc_month* (trying to set February 30, for example) cause unpredictable behavior and should be avoided. The February 28/29 rollover variation based on leap year is automatically corrected for.

The RTC defaults to operate in 12-hour plus AM/PM mode. To operate in 24-hour mode (where the AM/PM bits are disabled) set *rtc_mode* to 1. Care must be taken when switching between AM/PM mode and 24-hour mode to avoid setting the time to a invalid value. See [Figure 18](#) and [Figure 19](#) for the proper procedures.

Real-Time Clock Alarm

The real-time clock alarm function can be used to generate an interrupt (or a wakeup interrupt) at a pre-programmed time. If the appropriate bit in an interrupt enable register is set, an interrupt will be generated when the values in the RTC time registers become equal to the values in the RTC alarm registers. The register settings are shown in [Table 15](#).

Table 15. RTC Alarm Control Register Settings

PARAMETER	ADDRESS	BITS
<i>rtc_seconds_alarm</i> [6:0]	67	6:0
<i>rtc_minutes_alarm</i> [6:0]	68	6:0
<i>rtc_hours_alarm</i> [5:0]	69	5:0
<i>rtc_ampm_alarm</i>	69	7
<i>rtc_day_alarm</i> [5:0]	70	5:0
<i>rtc_month_alarm</i> [4:0]	71	4:0
<i>rtc_year_alarm</i> [7:0]	72	7:0

GPIO

Eight general-purpose I/O pins are provided, labeled GPIO0 through GPIO7. The direction of the eight GPIO pins can be independently set through control variable *gpio_oe*(7:0). A pin is an input if the corresponding bit of *gpio_oe* is 0; a pin is an output if the corresponding bit of *gpio_oe* is 1.

The control variable *gpio*(7:0) serves different functions, depending on whether it is read from or written to. A read operation from *gpio* returns the logic state of the eight GPIO pins regardless of their direction. A write to *gpio* sets the output state of the GPIO pins if they are configured as outputs; there is no effect if the pin is configured as an input. Note that the write value of *gpio* is stored in a register, so that if a GPIO pin is changed from an input to an output its logic state is set by the stored value of *gpio*. [Table 18](#) shows the *gpio* control variable settings.

The GPIO inputs can be optionally debounced if an RTC oscillator is running. Debouncing is controlled by *gpio_delay*, which is divided into eight 2-bit fields, each controlling a particular GPIO input according to [Table 16](#).

Table 16. gpio_delay

[15:14]	[13:12]	[11:10]	[9:8]	[7:6]	[5:4]	[3:2]	[1:0]
GPIO7	GPIO6	GPIO5	GPIO4	GPIO3	GPIO2	GPIO1	GPIO0

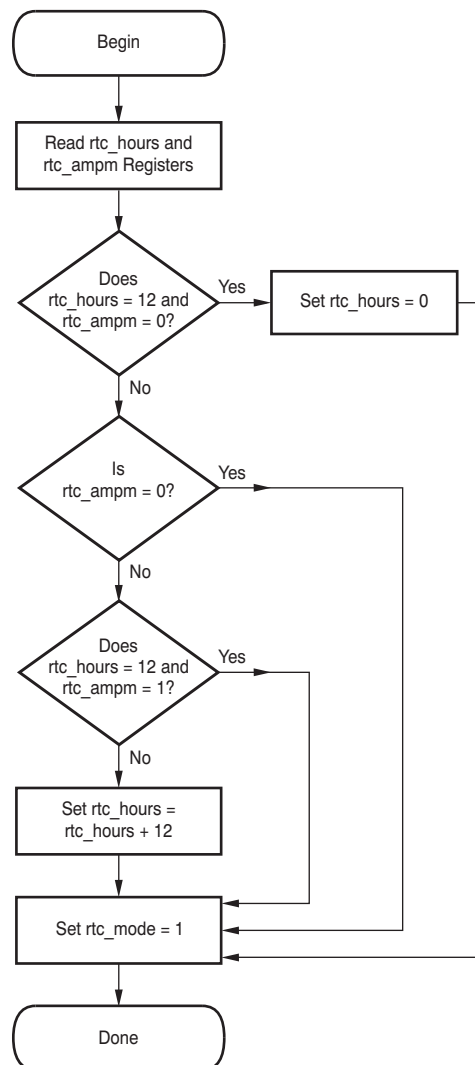

Figure 18. Procedure for Updating RTC Hour When Going from 12-Hour Mode to 24-Hour Mode

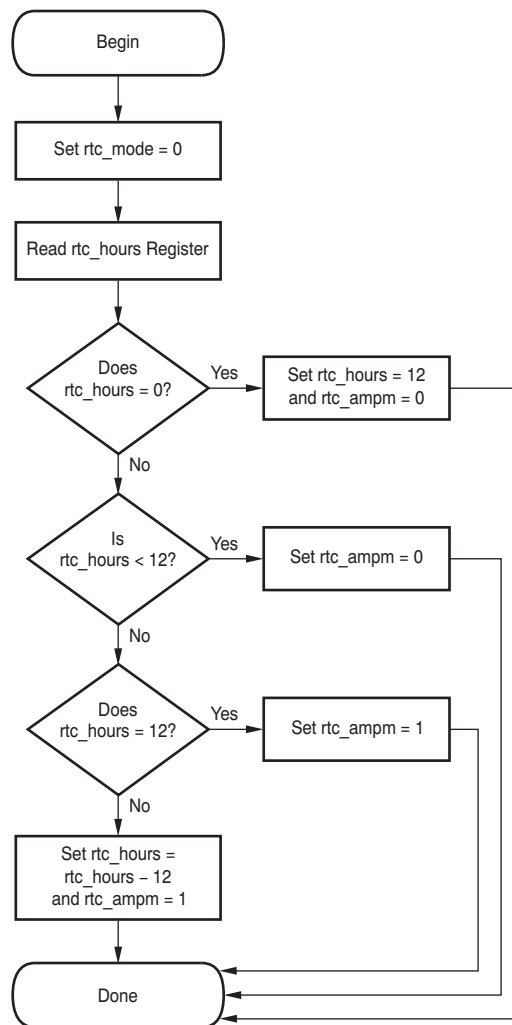

Figure 19. Procedure for Updating RTC Hour When Going from 24-Hour Mode to 12-Hour Mode

The debounce circuitry uses a clock divided from the RTC oscillator, with a debounce clock frequency given by Equation 24.

$$f_{\text{DEBOUNCE}} = \frac{f_{\text{RTC}}}{2^{2 \times \text{GPIO_DEBOUNCE_FREQ} + 1}} \quad (24)$$

If debounce is enabled, then in order for a GPIO input to change value (and possibly generate an interrupt if so programmed) it must remain stable for the number of debounce clock cycles (zero to three) given in the appropriate field of *gpio_delay*.

Table 17. General RTC Control Register Settings

PARAMETER	ADDRESS	BITS
rtc_ampm	75	7
rtc_comp_cnt[5:0]	64	12:7
rtc_comp_en	64	2
rtc_comp_val	66	15:0
rtc_day[5:0]	76	5:0
rtc_day_of_week[2:0]	79	2:0
rtc_en	64	0

Table 17. General RTC Control Register Settings (continued)

PARAMETER	ADDRESS	BITS
rtc_hours[5:0]	75	5:0
rtc_max_count[15:0]	65	15:0
rtc_minutes[6:0]	74	6:0
rtc_mode	64	1
rtc_month[4:0]	77	4:0
rtc_seconds[6:0]	73	6:0
rtc_year[7:0]	78	7:0

Table 18. GPIO Control Register Settings

PARAMETER	ADDRESS	BITS
gpio	43	11:0
gpio_delay[15:0]	44	15:0
gpio_oe	42	11:0

Alternate Registers—GPIO and Input Attenuator

If some of the GPIO pins on the AFE8220 are to be used to control the gain of a tuner, it may be desirable to change the GPIO values at the same time as the input attenuation to the DDC. To make this process more deterministic, the control parameters *gpio*, *ddc0_atten*, and *ddc1_atten* can be accessed through the alternate control register addresses of 96 and 97. By writing to register 96, *gpio* and *ddc0_atten* can be changed in a single register write; by writing to register 97, *gpio* and *ddc1_atten* can be changed in a single register write. [Table 19](#) shows the operation control settings for these parameters.

Table 19. Alternate GPIO and DDC Control Register Settings

PARAMETER	ADDRESS	BITS
gpio	96	7:0
	97	
ddc0_atten	96	14:12
ddc1_atten	97	

Interrupt Generators

There are three programmable interrupt pins; IRQ0, IRQ1, and IRQ2. Only the operation of IRQ0 is described here; IRQ1 and IRQ2 are programmed in the same way, using different control variables.

Interrupts can be generated from various sources. Interrupt generation is enabled through *irq0_en*, as [Table 20](#) shows.

Table 20. Interrupt Generation

BIT POSITION	SOURCE	BIT POSITION	SOURCE
0	GPIO	8	RTC alarm
1	None	9	RTC seconds rollover
2	I ² C Master done	10	RTC minutes rollover
3	Aux ADC done	11	RTC hours rollover
4	IFADC0 over-range	12	RTC months rollover
5	IFADC1 over-range	13	RTC day rollover
6	IFADC0 limit	14	RTC year rollover
7	IFADC1 limit	15	—

Setting a bit of *irq0_en* allows the generation of an interrupt for the corresponding event. All three IRQ generators run on the master clock (MCLK). When an interrupt event occurs on a given source signal, a value of 1 is written to the corresponding bit of *irq0_status*. This value is held in *irq0_status* until it is explicitly cleared by writing a 0 to the appropriate bit of *irq0_status*. A typical sequence upon receipt of an interrupt would be to poll *irq0_status* to determine the source of the interrupt, take whatever system action is appropriate, and then clear *irq0_status*.

Changes to any of the GPIO pins can also be programmed as interrupts. GPIO pin events are defined as changes from low to high or from high to low, depending on whether the corresponding bit in *irq0_gpio_edge* is high or low. GPIO interrupts are enabled by setting the corresponding bit in *irq0_gpio_en*; they are identified and cleared by reading and writing the corresponding bit in *irq0_gpio_status*.

The behavior of the IRQ0 pin is determined by *irq0_sense*. When *irq0_sense* is 0, IRQ0 is normally low and goes high on an unmasked interrupt event. When *irq0_sense* is 1, IRQ0 is normally high and goes low on an unmasked interrupt event. [Table 21](#) shows the *irq0*, *irq1*, and *irq2* operations control settings.

Table 21. IRQ Control Register Settings

PARAMETER	ADDRESS	BITS
<i>irq0_en</i>	50	15:0
<i>irq1_en</i>	55	15:0
<i>irq2_en</i>	60	15:0
<i>irq0_gpio_edge</i>	48	11:0
<i>irq1_gpio_edge</i>	53	11:0
<i>irq2_gpio_edge</i>	58	11:0
<i>irq0_gpio_en</i>	49	11:0
<i>irq1_gpio_en</i>	54	11:0
<i>irq2_gpio_en</i>	59	11:0
<i>irq0_gpio_status</i>	52	11:0
<i>irq1_gpio_status</i>	57	11:0
<i>irq2_gpio_status</i>	62	11:0
<i>irq0_sense</i>	2	1
<i>irq1_sense</i>	2	2
<i>irq2_sense</i>	2	3
<i>irq0_status</i>	51	15:0
<i>irq1_status</i>	56	15:0
<i>irq2_status</i>	61	15:0

Wakeup Interrupt Generator

The WAKEUP interrupt generator functions in the same way as the IRQ generators with the following exceptions:

1. The WAKEUP generator runs on the RTC clock instead of MCLK;
2. The WAKEUP generator operates when the AFE is in low-power mode, whereas the IRQ generators do not; and
3. The interrupt sources for the WAKEUP interrupt generator are slightly different.

[Table 22](#) shows the wakeup control settings. [Table 23](#) shows the generator functions.

Table 22. Wakeup Control Register Settings

PARAMETER	ADDRESS	BITS
<i>wakeup_sense</i>	2	0
<i>wakeup_gpio_edge</i>	80	11:0
<i>wakeup_gpio_en</i>	81	11:0
<i>wakeup_en</i>	82	15:0
<i>wakeup_status</i>	83	15:0
<i>wakeup_gpio_status</i>	84	11:0

Table 23. WAKEUP Interrupt Generator

BIT POSITION	SOURCE
0	GPIO
1	None
2	None
3	None
4	None
5	None
6	None
7	None
8	RTC alarm
9	RTC seconds rollover
10	RTC minutes rollover
11	RTC hours rollover
12	RTC months rollover
13	RTC day rollover
14	RTC year rollover

Control Register Assignments

Table 24. Control Registers

Address: 1 Description: Functional Block Enables			
Bits	Range	Action	Parameter Name
1:0	0..3	Enable IFADC converters	ifadc_en(1:0)
2	0/1	Gain control for IF_ADC0	ifadc_gain0
3	0/1	Gain control for IF_ADC1	ifadc_gain1
5:4	0..3	Enable DDCs	ddc_en(1:0)
6	0/1	Synchronize DDC0 and DDC1	ddc_sync
7	0/1	Enable primary IF data interface	dout_en
8	0/1	Enable secondary IF data interface	bb_en
10:9	0..3	Enable auxiliary DACs	cdac_en(1:0)
11	—	Not used	aux_adc_en
12	0/1	Enable RTC output pins	rtc_oe
13	0/1	Enable reference clock output pins	refclk_en
Address: 2 Description: Interrupt Output Level Configuration			
Bits	Range	Action	Parameter Name
0	0/1	0 = Active high WAKEUP interrupt	wakeup_sense
		1 = Active low WAKEUP interrupt	
1	0/1	0 = Active high IRQ0 interrupt	irq0_sense
		1 = Active low IRQ0 interrupt	
2	0/1	0 = Active high IRQ1 interrupt	irq1_sense
		1 = Active low IRQ1 interrupt	
3	0/1	0 = Active high IRQ2 interrupt	irq2_sense
		1 = Active low IRQ2 interrupt	
Address: 3 Description: DDC0 Input Attenuator			
Bits	Range	Action	Parameter Name
2:0	0..6	Attenuation setting for DDC0	ddc_atten(2:0)
Address: 4 Description: DDC0 Input Attenuator			
Bits	Range	Action	Parameter Name
15:0	0..65535	Delay setting for DDC0 attenuator	ddc0_delay(15:0)
Address: 5 Description: DDC0 NCO Frequency			
Bits	Range	Action	Parameter Name
15:0	0..65535	Upper bytes of DDC0 NCO frequency	ddc0_demod_freq(31:16)
Address: 6 Description: DDC0 NCO Frequency			
Bits	Range	Action	Parameter Name
15:0	0..65535	Lower bytes of DDC0 NCO frequency	ddc0_demod_freq(15:0)
Address: 7 Description: DDC0 NCO Phase			
Bits	Range	Action	Parameter Name
15:0	0..65535	Upper bytes of DDC0 NCO phase	ddc0_demod_phase(31:16)

Table 24. Control Registers (continued)

Address: 8			
Description: DDC0 NCO Phase (continued)			
Bits	Range	Action	Parameter name
15:0	0..65535	Lower bytes of DDC0 NCO phase	ddc0_demod_phase(15:0)
Address: 9			
Description: DDC0 CIC Filter			
Bits	Range	Action	Parameter Name
8:0	4..256	CIC filter decimation rate	ddc0_cic_dec_rate(8:0)
Address: 10			
Description: DDC0 CIC Filter			
Bits	Range	Action	Parameter Name
5:0	0..63	CIC filter post-filter shift	ddc0_cic_shift(5:0)
11:6	0..32	CIC filter post-filter scale	ddc0_cic_scale(5:0)
Address: 11			
Description: DDC0 FIR Filter 1			
Bits	Range	Action	Parameter Name
1:0	0..3	FIR filter mode	ddc0_fir1_mode(1:0)
7:2	0..63	Number of coefficients to process	ddc0_fir1_ncoeffs(5:0)
13:8	0..63	Coefficient base address	ddc0_fir1_base_addr(5:0)
Address: 12			
Description: DDC0 FIR Filter 2A			
Bits	Range	Action	Parameter Name
1:0	0..3	FIR filter mode	ddc0_fir2a_mode(1:0)
8:2	0..127	Number of coefficients to process	ddc0_fir2a_ncoeffs(6:0)
15:9	0..127	Coefficient base address	ddc0_fir2a_base_addr(6:0)
Address: 13			
Description: DDC0 FIR Filter 2B			
Bits	Range	Action	Parameter Name
1:0	0..3	FIR filter mode	ddc0_fir2b_mode(1:0)
8:2	0..127	Number of coefficients to process	ddc0_fir2b_ncoeffs(6:0)
15:9	0..127	Coefficient base address	ddc0_fir2b_base_addr(6:0)
Address: 14			
Description: DDC0 FIR Filter Extended Features			
Bits	Range	Action	Parameter Name
3:0	0..15	Post-filter shift for FIR filter 2A	ddc0_fir2a_shift(3:0)
7:4	0..15	Post-filter shift for FIR filter 2B	ddc0_fir2b_shift(3:0)
8	0/1	Enable interleave mode for FIR filter 2A and FIR filter 2B	ddc0_interleave
9	0/1	Disable decimation for FIR filter 1	ddc0_fir1_noddec
10	0/1	Disable decimation for FIR filter 2A and FIR filter 2B	ddc0_fir2_noddec
Address: 15			
Description: DDC1 Input Attenuator			
Bits	Range	Action	Parameter Name
2:0	0..6	Attenuation setting for DDC1	ddc1_atten(2:0)
Address: 16			
Description: DDC1 Input Attenuator			
Bits	Range	Action	Parameter Name
15:0	0..65535	Delay setting for DDC1 attenuator	ddc1_delay(15:0)

Table 24. Control Registers (continued)

Address: 17			
Description: DDC1 NCO Frequency			
Bits	Range	Action	Parameter Name
15:0	0..65535	Upper bytes of DDC1 NCO frequency	ddc1_demod_freq(31:16)
Address: 18			
Description: DDC1 NCO Frequency			
Bits	Range	Action	Parameter Name
15:0	0..65535	Lower bytes of DDC1 NCO frequency	ddc1_demod_freq(15:0)
Address: 19			
Description: DDC1 NCO Phase			
Bits	Range	Action	Parameter Name
15:0	0..65535	Upper bytes of DDC1 NCO phase	ddc1_demod_phase(31:16)
Address: 20			
Description: DDC1 NCO Phase			
Bits	Range	Action	Parameter Name
15:0	0..65536	Lower bytes of DDC1 NCO phase	ddc1_demod_phase(15:0)
Address: 21			
Description: DDC1 CIC Filter Decimation			
Bits	Range	Action	Parameter Name
8:0	4..256	CIC filter decimation rate	ddc1_cic_dec_rate(8:0)
Address: 22			
Description: DDC1 CIC Filter			
Bits	Range	Action	Parameter Name
5:0	0..63	CIC filter post-filter shift	ddc1_cic_shift(5:0)
11:6	0..32	CIC filter post-filter scale	ddc1_cic_scale(5:0)
Address: 23			
Description: DDC1 FIR Filter 1			
Bits	Range	Action	Parameter Name
1:0	0..3	FIR filter mode	ddc1_fir1_mode(1:0)
7:2	0..63	Number of coefficients to process	ddc1_fir1_ncoeffs(5:0)
13:8	0..63	Coefficient base address	ddc1_fir1_base_addr(5:0)
Address: 24			
Description: DDC1 FIR Filter 2A			
Bits	Range	Action	Parameter Name
1:0	0..3	FIR filter mode	ddc1_fir2a_mode(1:0)
8:2	0..127	Number of coefficients to process	ddc1_fir2a_ncoeffs(6:0)
15:9	0..127	Coefficient base address	ddc1_fir2a_base_addr(6:0)
Address: 25			
Description: DDC1 FIR Filter 2B			
Bits	Range	Action	Parameter Name
1:0	0..3	FIR filter mode	ddc1_fir2b_mode(1:0)
8:2	0..127	Number of coefficients to process	ddc1_fir2b_ncoeffs(6:0)
15:9	0..127	Coefficient base address	ddc1_fir2b_base_addr(6:0)

Table 24. Control Registers (continued)

Address: 26			
Description: DDC1 FIR Filter Extended Features			
Bits	Range	Action	Parameter Name
3:0	0..15	Post-filter shift for FIR filter 2A	ddc1_fir2a_shift(3:0)
7:4	0..15	Post-filter shift for FIR filter 2B	ddc1_fir2b_shift(3:0)
8	0/1	Enable interleave mode for FIR filter 2A and FIR filter 2B	ddc1_interleave
9	0/1	Disable decimation for FIR filter 1	ddc1_fir1_noddec
10	0/1	Disable decimation for FIR filter 2A and FIR filter 2B	ddc1_fir2_noddec
Address: 27			
Description: Data Interface Configuration			
Bits	Range	Action	Parameter Name
15:0	0..65535	Configuration for IF_DOUT0	if_dout0_config
Address: 28			
Description: Data Interface Configuration			
Bits	Range	Action	Parameter Name
15:0	0..65535	Configuration for IF_DOUT1	if_dout1_config
Address: 29			
Description: Data Interface Configuration			
Bits	Range	Action	Parameter Name
15:0	0..65535	Configuration for IF_DOUT2	if_dout2_config
Address: 30			
Description: Data Interface Configuration			
Bits	Range	Action	Parameter Name
15:0	0..65535	Configuration for IF_DOUT3	if_dout3_config
Address: 31			
Description: Data Interface Configuration			
Bits	Range	Action	Parameter Name
4:0	0..16	Divide factor to derive IF_DCLK from MCLK	if_dclk_div(4:0)
5	0/1	0: IF_DFSD and IF_DOUTx change on rising edge of IF_DCLK 1: IF_DFSD and IF_DOUTx change on falling edge of IF_DCLK	if_dclk_edge
6	0/1	0: IF_DFSD generated by DDC0 1: IF_DFSD generated by DDC1	if_dfso_select
8:7	0..2	0: IF_DFSD one IF_DCLK cycle wide 1: IF_DFSD toggles once per frame 2: IF_DFSD 16 IF_DCLK cycles wide	if_dfso_mode(1:0)
Address: 32–36			
Description: Not Used			
Bits	Range	Action	Parameter Name
—	—	—	—
Address: 37			
Description: CDAC0 Output			
Bits	Range	Action	Parameter Name
11:0	0..4095	Output value for CDAC0	cdac0_out(11:0)
Address: 38			
Description: CDAC1 Output			
Bits	Range	Action	Parameter Name
11:0	0..4095	Output value for CDAC1	cdac1_out(11:0)

Table 24. Control Registers (continued)

Address: 39			
Description: Not Used			
Bits	Range	Action	Parameter Name
—	—	—	—
Address: 40			
Description: Reference Clock Configuration			
Bits	Range	Action	Parameter Name
15:0	0..4095	Low period (in units of MCLK cycles) for reference clock output	refclk_lo(15:0)
Address: 41			
Description: Reference Clock Configuration			
Bits	Range	Action	Parameter Name
15:0	0..4095	High period (in units of MCLK cycles) for reference clock output	refclk_hi(15:0)
Address: 42			
Description: GPIO Configuration			
Bits	Range	Action	Parameter Name
0	0/1	0 = GPIO0 set as input	gpio_oe(0)
		1 = GPIO0 set as output	
1	0/1	0 = GPIO1 set as input	gpio_oe(1)
		1 = GPIO1 set as output	
2	0/1	0 = GPIO2 set as input	gpio_oe(2)
		1 = GPIO2 set as output	
3	0/1	0 = GPIO3 set as input	gpio_oe(3)
		1 = GPIO3 set as output	
4	0/1	0 = GPIO4 set as input	gpio_oe(4)
		1 = GPIO4 set as output	
5	0/1	0 = GPIO5 set as input	gpio_oe(5)
		1 = GPIO5 set as output	
6	0/1	0 = GPIO6 set as input	gpio_oe(6)
		1 = GPIO6 set as output	
7	0/1	0 = GPIO7 set as input	gpio_oe(7)
		1 = GPIO7 set as output	

Table 24. Control Registers (continued)

Address: 43			
Description: GPIO Configuration (continued)			
Bits	Range	Action	Parameter Name
0	0/1	Register write: drives value on GPIO0 pin if enabled as output	gpio(0)
		Register read: returns value on GPIO0 pin	
1	0/1	Register write: drives value on GPIO1 pin if enabled as output	gpio(1)
		Register read: returns value on GPIO1 pin	
2	0/1	Register write: drives value on GPIO2 pin if enabled as output	gpio(2)
		Register read: returns value on GPIO2 pin	
3	0/1	Register write: drives value on GPIO3 pin if enabled as output	gpio(3)
		Register read: returns value on GPIO3 pin	
4	0/1	Register write: drives value on GPIO4 pin if enabled as output	gpio(4)
		Register read: returns value on GPIO4 pin	
5	0/1	Register write: drives value on GPIO5 pin if enabled as output	gpio(5)
		Register read: returns value on GPIO5 pin	
6	0/1	Register write: drives value on GPIO6 pin if enabled as output	gpio(6)
		Register read: returns value on GPIO6 pin	
7	0/1	Register write: drives value on GPIO7 pin if enabled as output	gpio(7)
		Register read: returns value on GPIO7 pin	
Address: 44			
Description: GPIO Configuration			
Bits	Range	Action	Parameter Name
1:0	0..3	GPIO0 debounce setting	gpio_delay(1:0)
3:2	0..3	GPIO1 debounce setting	gpio_delay(3:2)
5:4	0..3	GPIO2 debounce setting	gpio_delay(5:4)
7:6	0..3	GPIO3 debounce setting	gpio_delay(7:6)
9:8	0..3	GPIO4 debounce setting	gpio_delay(9:8)
11:10	0..3	GPIO5 debounce setting	gpio_delay(11:10)
13:12	0..3	GPIO6 debounce setting	gpio_delay(13:12)
15:14	0..3	GPIO7 debounce setting	gpio_delay(15:14)
Address: 45			
Description: Not Used			
Bits	Range	Action	Parameter Name
—	—	—	—
Address: 46			
Description: IF ADC Alarm			
Bits	Range	Action	Parameter Name
11:0	0..2047	Alarm limit for IF_ADC0	ifadc0_limit(11:0)
Address: 47			
Description: IF ADC Alarm			
Bits	Range	Action	Parameter Name
11:0	0..2047	Alarm limit for IF_ADC1	ifadc1_limit(11:0)
Address: 48			
Description: IRQ0 Configuration			
Bits	Range	Action	Parameter Name
11:0	0..4095	GPIO input edge select for IRQ0	irq0_gpio_edge(11:0)

Table 24. Control Registers (continued)

Address: 49			
Description: IRQ0 Configuration			
Bits	Range	Action	Parameter Name
11:0	0..4095	IRQ0 GPIO enable	irq0_gpio_en(11:0)
Address: 50			
Description: IRQ0 Configuration			
Bits	Range	Action	Parameter Name
15:0	0..65535	IRQ0 enable	irq0_en(15:0)
Address: 51			
Description: IRQ0 Status			
Bits	Range	Action	Parameter Name
15:0	0..65535	Register read: returns IRQ0 status	irq0_status(15:0)
		Register write: clears interrupt bit if 1 is written	
Address: 52			
Description: IRQ0 GPIO Status			
Bits	Range	Action	Parameter Name
11:0	0..4095	Register read: returns IRQ0 status	irq0_gpio_status(11:0)
		Register write: clears interrupt bit if 1 is written	
Address: 53			
Description: IRQ1 Configuration			
Bits	Range	Action	Parameter Name
11:0	0..4095	GPIO input edge select for IRQ1	irq1_gpio_edge(11:0)
Address: 54			
Description: IRQ1 Configuration			
Bits	Range	Action	Parameter Name
11:0	0..4095	IRQ1 GPIO enable	irq1_gpio_en(11:0)
Address: 55			
Description: IRQ1 Configuration			
Bits	Range	Action	Parameter Name
15:0	0..65535	IRQ1 enable	irq1_en(15:0)
Address: 56			
Description: IRQ1 Status			
Bits	Range	Action	Parameter Name
15:0	0..65535	Register read: returns IRQ1 status	irq1_status(15:0)
		Register write: clears interrupt bit if 1 is written	
Address: 57			
Description: IRQ1 GPIO Status (continued)			
Bits	Range	Action	Parameter Name
11:0	0..4095	Register read: returns IRQ1 status	irq1_gpio_status(11:0)
		Register write: clears interrupt bit if 1 is written	
Address: 58			
Description: IRQ2 Configuration			
Bits	Range	Action	Parameter Name
11:0	0..4095	GPIO input edge select for IRQ2	irq2_gpio_edge(11:0)
Address: 59			
Description: IRQ2 Configuration			
Bits	Range	Action	Parameter Name
11:0	0..4095	IRQ2 GPIO enable	irq2_gpio_en(11:0)

Table 24. Control Registers (continued)

Address: 60			
Description: IRQ2 Configuration			
Bits	Range	Action	Parameter Name
15:0	0..65535	IRQ2 enable	irq2_en(15:0)
Address: 61			
Description: IRQ2 Status			
Bits	Range	Action	Parameter Name
15:0	0..65535	Register read: returns IRQ2 status	irq2_status(15:0)
		Register write: clears interrupt bit if 1 is written	
Address: 62			
Description: IRQ2 GPIO Status			
Bits	Range	Action	Parameter Name
11:0	0..4095	Register read: returns IRQ2 status	irq2_gpio_status(11:0)
		Register write: clears interrupt bit if 1 is written	
Address: 63			
Description: Not Used			
Bits	Range	Action	Parameter Name
—	—	—	—
Address: 64			
Description: Real-Time Clock Configuration			
Bits	Range	Action	Parameter Name
0	0/1	0 = Freeze real-time clock	rtc_en
		1 = Enable real-time clock operation	
1	0/1	0:12 hour mode	rtc_mode
		1:24 hour mode	
2	0/1	Enable clock compensation	rtc_comp_en
3	0/1	Enable clock test mode	rtc_test_en
6:4	0..4	Clock test mode selection	rtc_test_mode(2:0)
12:7	0..31	Compensation count	rtc_comp_cnt(5:0)
15:13	0..7	Frequency select for GPIO debounce	gpio_debounce_freq(2:0)
Address: 65			
Description: Real-Time Clock Configuration			
Bits	Range	Action	Parameter Name
15:0	0..32767	Real-time one second terminal count	rtc_max_count(15:0)
Address: 66			
Description: Real-Time Clock Configuration (continued)			
Bits	Range	Action	Parameter Name
15:0	–32768..32767	Real-time clock compensation value	rtc_comp_val(15:0)
Address: 67			
Description: Real-Time Clock Alarm			
Bits	Range	Action	Parameter Name
6:0	0..59	Seconds alarm setting	rtc_seconds_alarm(6:0)
Address: 68			
Description: Real-Time Clock Alarm			
Bits	Range	Action	Parameter Name
6:0	0..59	Minutes alarm setting	rtc_minutes_alarm(6:0)



Table 24. Control Registers (continued)

Address: 69			
Description: Realtime Clock Alarm			
Bits	Range	Action	Parameter Name
5:0	1..12	Hour alarm setting, 12-hour mode	rtc_hours_alarm(5:0)
	0..23	Hour alarm setting, 24-hour mode	
6	—	Not used	—
7	0/1	12-hour mode: 0 = AM, 1 = PM	rtc_ampm_alarm
		24-hour mode: not used	
Address: 70			
Description: Real-Time Clock Alarm			
Bits	Range	Action	Parameter Name
5:0	1..31	Day of the month alarm setting	rtc_day_alarm(5:0)
Address: 71			
Description: Real-Time Clock Alarm			
Bits	Range	Action	Parameter Name
4:0	1..12	Month alarm setting	rtc_months_alarm(4:0)
Address: 72			
Description: Real-Time Clock Alarm			
Bits	Range	Action	Parameter Name
7:0	—	Year alarm setting	rtc_year_alarm(7:0)
Address: 73			
Description: Real-Time Clock Current Time			
Bits	Range	Action	Parameter Name
6:0	0..59	Seconds register	rtc_seconds(6:0)
14:7	—	Not used	—
15	0/1	Real-time clock busy (read only)	rtc_busy
Address: 74			
Description: Real-Time Clock Current Time			
Bits	Range	Action	Parameter Name
6:0	0..59	Minutes register	rtc_minutes(6:0)
14:7	—	Not used	—
15	0/1	Real-time clock busy (read only)	rtc_busy
Address: 75			
Description: Real-Time Clock Current Time (continued)			
Bits	Range	Action	Parameter Name
5:0	1..12	Hour register, 12-hour mode	rtc_hours(5:0)
	0..23	Hour register, 24-hour mode	
6	—	Not used	—
7	0/1	12-hour mode: 0 = AM, 1 = PM	rtc_ampm
		24-hour mode: not used	
14:8	—	Not used	—
15	0/1	Real-time clock busy (read only)	rtc_busy
Address: 76			
Description: Real-Time Clock Current Time			
Bits	Range	Action	Parameter Name
5:0	1..31	Day of month register	rtc_day(5:0)
14:6	—	Not used	—
15	0/1	Real-time clock busy (read only)	rtc_busy

Table 24. Control Registers (continued)

Address: 77			
Description: Real-Time Clock Current Time			
Bits	Range	Action	Parameter Name
4:0	1..12	Month register	rtc_month(4:0)
14:5	—	Not used	—
15	0/1	Real-time clock busy (read only)	rtc_busy
Address: 78			
Description: Real-Time Clock Current Time			
Bits	Range	Action	Parameter Name
7:0	0..99	Year register	rtc_year(7:0)
14:8	—	Not used	—
15	0/1	Real-time clock busy (read only)	rtc_busy
Address: 79			
Description: Real-Time Clock Current Time			
Bits	Range	Action	Parameter Name
2:0	0..6	Day of week	rtc_day_of_week(2:0)
14:3	—	Not used	—
15	0/1	Real-time clock busy (read only)	rtc_busy
Address: 80			
Description: WAKEUP Configuration			
Bits	Range	Action	Parameter Name
11:0	0..4095	GPIO input edge select for WAKEUP	wakeup_gpio_edge(11:0)
Address: 81			
Description: WAKEUP Configuration			
Bits	Range	Action	Parameter Name
11:0	0..4095	WAKEUP GPIO enable	wakeup_gpio_en(11:0)
Address: 82			
Description: WAKEUP Configuration			
Bits	Range	Action	Parameter Name
15:0	0..65535	WAKEUP enable	wakeup_en(15:0)
Address: 83			
Description: WAKEUP Status			
Bits	Range	Action	Parameter Name
15:0	0..65535	Register read: returns WAKEUP status	wakeup_status(15:0)
		Register write: clears interrupt bit if 1 is written	
Address: 84			
Description: WAKEUP GPIO Status			
Bits	Range	Action	Parameter Name
11:0	0..4095	Register read: returns WAKEUP status	wakeup_gpio_status(11:0)
		Register write: clears interrupt bit if 1 is written	

PACKAGING INFORMATION

Orderable Device	Status (1)	Package Type	Package Drawing	Pins	Package Qty	Eco Plan (2)	Lead/Ball Finish	MSL Peak Temp (3)	Op Temp (°C)	Top-Side Markings (4)	Samples
AFE8220IPZPQ1	ACTIVE	HTQFP	PZP	100	90	Green (RoHS & no Sb/Br)	CU NIPDAU	Level-3-260C-168 HR	-40 to 85	AFE8220Q	
AFE8220TPZPQ1	ACTIVE	HTQFP	PZP	100	90	Green (RoHS & no Sb/Br)	CU NIPDAU	Level-3-260C-168 HR	-40 to 105	AFE8220QT	

(1) The marketing status values are defined as follows:

ACTIVE: Product device recommended for new designs.

LIFEBUY: TI has announced that the device will be discontinued, and a lifetime-buy period is in effect.

NRND: Not recommended for new designs. Device is in production to support existing customers, but TI does not recommend using this part in a new design.

PREVIEW: Device has been announced but is not in production. Samples may or may not be available.

OBSOLETE: TI has discontinued the production of the device.

(2) Eco Plan - The planned eco-friendly classification: Pb-Free (RoHS), Pb-Free (RoHS Exempt), or Green (RoHS & no Sb/Br) - please check <http://www.ti.com/productcontent> for the latest availability information and additional product content details.

TBD: The Pb-Free/Green conversion plan has not been defined.

Pb-Free (RoHS): TI's terms "Lead-Free" or "Pb-Free" mean semiconductor products that are compatible with the current RoHS requirements for all 6 substances, including the requirement that lead not exceed 0.1% by weight in homogeneous materials. Where designed to be soldered at high temperatures, TI Pb-Free products are suitable for use in specified lead-free processes.

Pb-Free (RoHS Exempt): This component has a RoHS exemption for either 1) lead-based flip-chip solder bumps used between the die and package, or 2) lead-based die adhesive used between the die and leadframe. The component is otherwise considered Pb-Free (RoHS compatible) as defined above.

Green (RoHS & no Sb/Br): TI defines "Green" to mean Pb-Free (RoHS compatible), and free of Bromine (Br) and Antimony (Sb) based flame retardants (Br or Sb do not exceed 0.1% by weight in homogeneous material)

(3) MSL, Peak Temp. -- The Moisture Sensitivity Level rating according to the JEDEC industry standard classifications, and peak solder temperature.

(4) Only one of markings shown within the brackets will appear on the physical device.

Important Information and Disclaimer: The information provided on this page represents TI's knowledge and belief as of the date that it is provided. TI bases its knowledge and belief on information provided by third parties, and makes no representation or warranty as to the accuracy of such information. Efforts are underway to better integrate information from third parties. TI has taken and continues to take reasonable steps to provide representative and accurate information but may not have conducted destructive testing or chemical analysis on incoming materials and chemicals. TI and TI suppliers consider certain information to be proprietary, and thus CAS numbers and other limited information may not be available for release.

In no event shall TI's liability arising out of such information exceed the total purchase price of the TI part(s) at issue in this document sold by TI to Customer on an annual basis.

MECHANICAL DATA

PZP (S-PQFP-G100)

PowerPAD™ PLASTIC QUAD FLATPACK

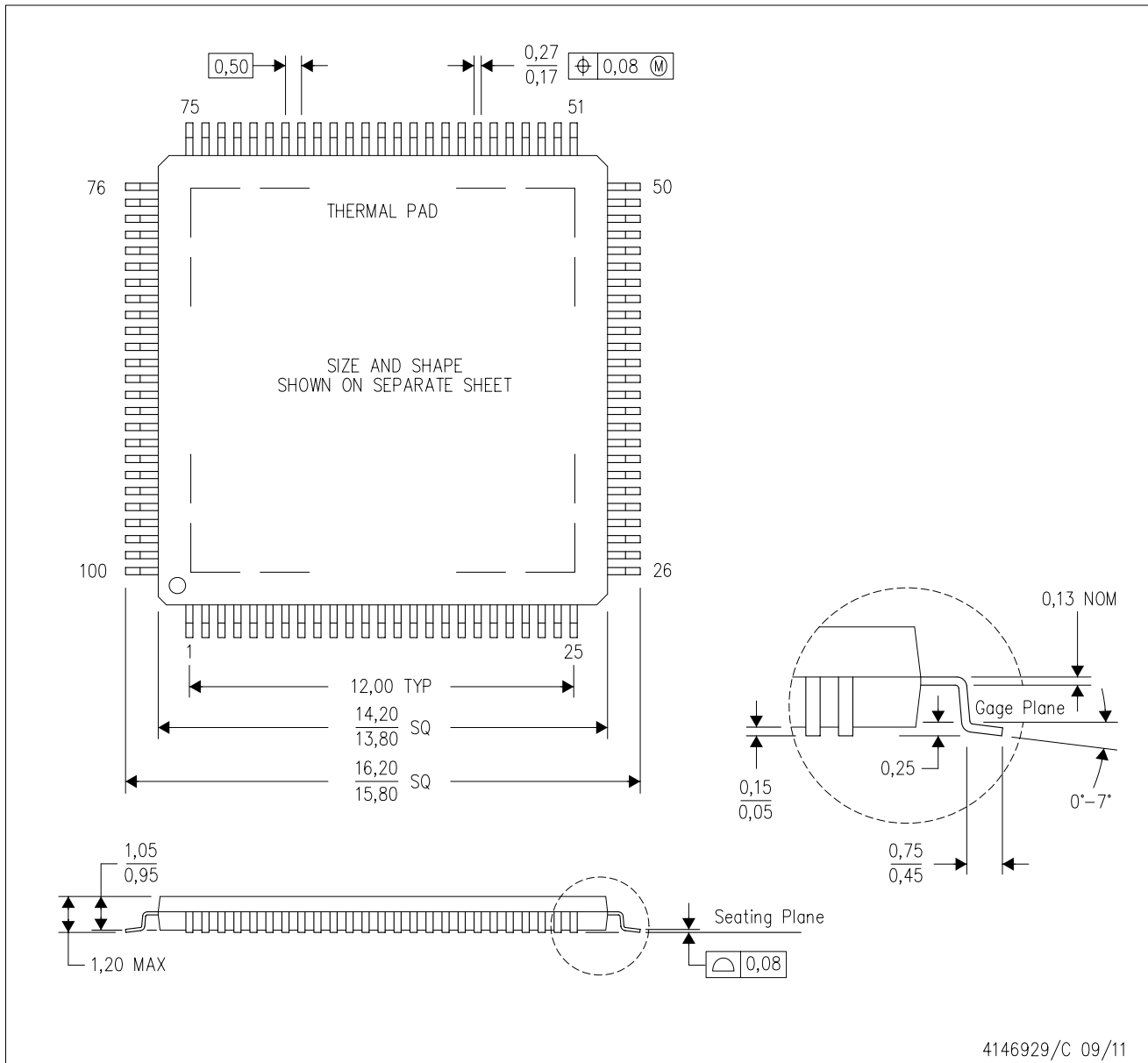

- NOTES:
- A. All linear dimensions are in millimeters.
 - B. This drawing is subject to change without notice.
 - C. Body dimensions do not include mold flash or protrusion
 - D. This package is designed to be soldered to a thermal pad on the board. Refer to Technical Brief, PowerPad Thermally Enhanced Package, Texas Instruments Literature No. SLMA002 for information regarding recommended board layout. This document is available at www.ti.com <<http://www.ti.com>>.
 - E. See the additional figure in the Product Data Sheet for details regarding the exposed thermal pad features and dimensions.
 - F. Falls within JEDEC MS-026

PowerPAD is a trademark of Texas Instruments.

PZP (S-PQFP-G100)

PowerPAD™ PLASTIC QUAD FLATPACK

THERMAL INFORMATION

This PowerPAD™ package incorporates an exposed thermal pad that is designed to be attached to a printed circuit board (PCB). The thermal pad must be soldered directly to the PCB. After soldering, the PCB can be used as a heatsink. In addition, through the use of thermal vias, the thermal pad can be attached directly to the appropriate copper plane shown in the electrical schematic for the device, or alternatively, can be attached to a special heatsink structure designed into the PCB. This design optimizes the heat transfer from the integrated circuit (IC).

For additional information on the PowerPAD package and how to take advantage of its heat dissipating abilities, refer to Technical Brief, PowerPAD Thermally Enhanced Package, Texas Instruments Literature No. SLMA002 and Application Brief, PowerPAD Made Easy, Texas Instruments Literature No. SLMA004. Both documents are available at www.ti.com.

The exposed thermal pad dimensions for this package are shown in the following illustration.

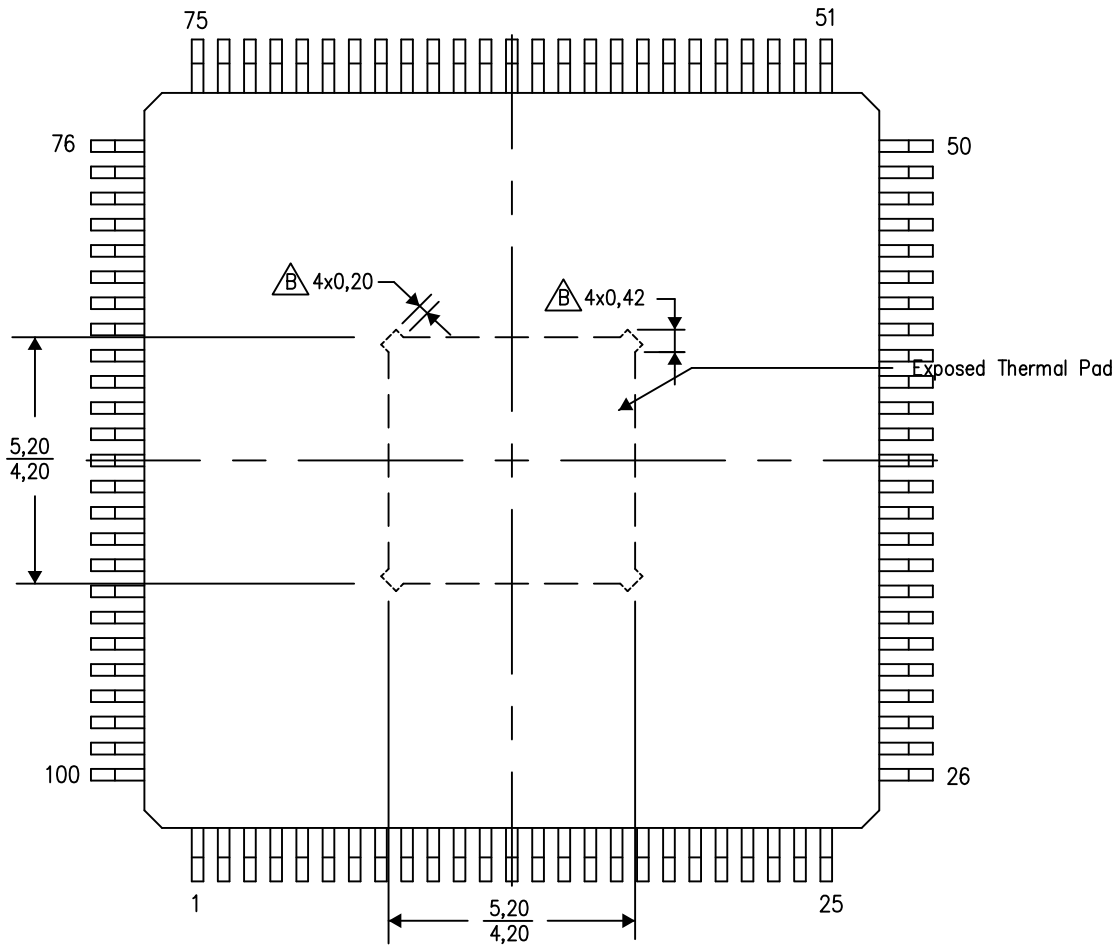

Top View

Exposed Thermal Pad Dimensions

4206333-2/1 12/12

NOTE: A. All linear dimensions are in millimeters

 Tie strap features may not be present.

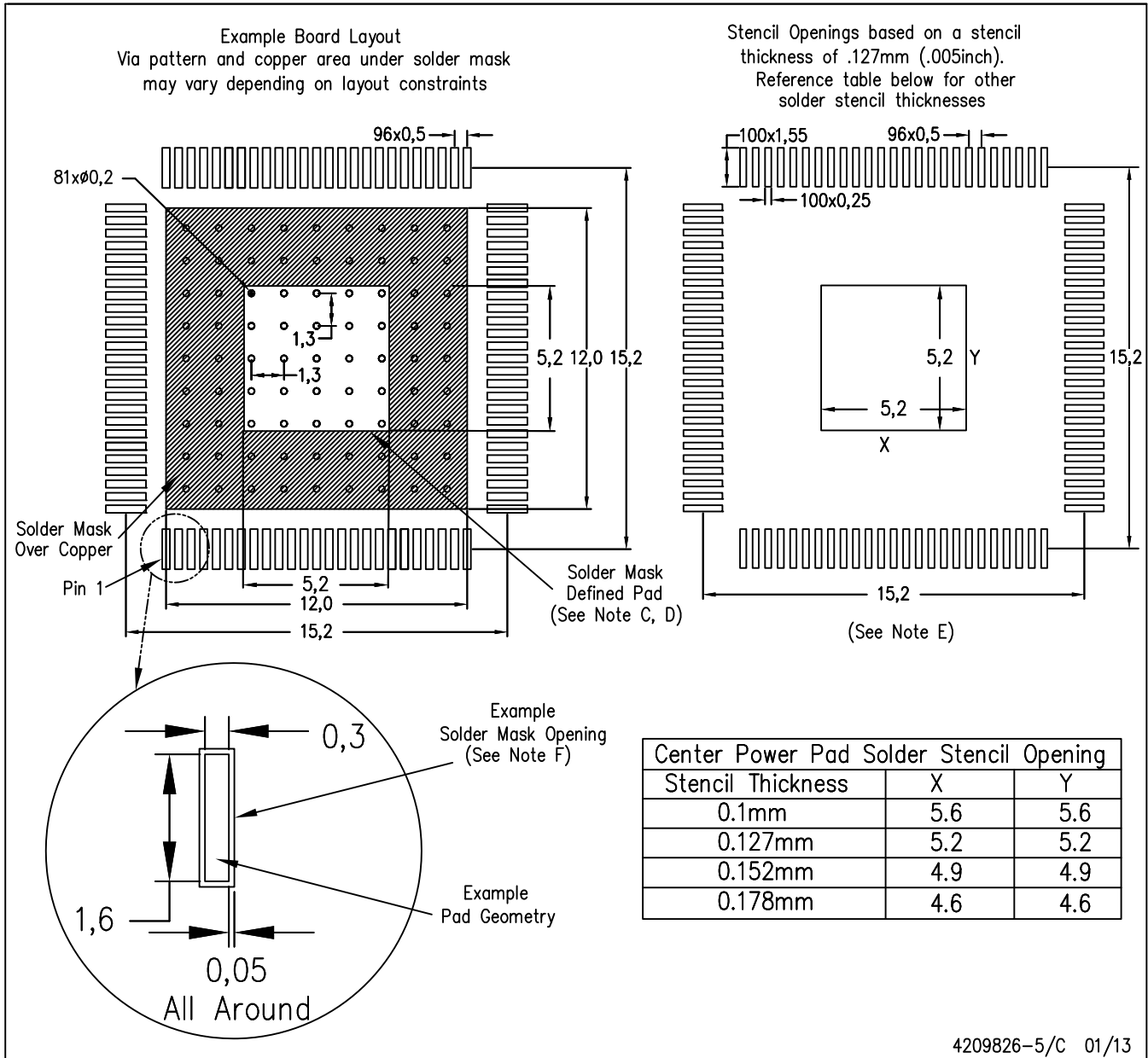

4209826-5/C 01/13

- NOTES:
- A. All linear dimensions are in millimeters.
 - B. This drawing is subject to change without notice.
 - C. Customers should place a note on the circuit board fabrication drawing not to alter the center solder mask defined pad.
 - D. This package is designed to be soldered to a thermal pad on the board. Refer to Technical Brief, PowerPad Thermally Enhanced Package, Texas Instruments Literature No. SLMA002, SLMA004, and also the Product Data Sheets for specific thermal information, via requirements, and recommended board layout. These documents are available at www.ti.com <<http://www.ti.com>>. Publication IPC-7351 is recommended for alternate designs.
 - E. Laser cutting apertures with trapezoidal walls and also rounding corners will offer better paste release. Customers should contact their board assembly site for stencil design recommendations. Example stencil design based on a 50% volumetric metal load solder paste. Refer to IPC-7525 for other stencil recommendations.
 - F. Customers should contact their board fabrication site for solder mask tolerances between and around signal pads.

PowerPAD is a trademark of Texas Instruments.

IMPORTANT NOTICE

Texas Instruments Incorporated and its subsidiaries (TI) reserve the right to make corrections, enhancements, improvements and other changes to its semiconductor products and services per JESD46, latest issue, and to discontinue any product or service per JESD48, latest issue. Buyers should obtain the latest relevant information before placing orders and should verify that such information is current and complete. All semiconductor products (also referred to herein as "components") are sold subject to TI's terms and conditions of sale supplied at the time of order acknowledgment.

TI warrants performance of its components to the specifications applicable at the time of sale, in accordance with the warranty in TI's terms and conditions of sale of semiconductor products. Testing and other quality control techniques are used to the extent TI deems necessary to support this warranty. Except where mandated by applicable law, testing of all parameters of each component is not necessarily performed.

TI assumes no liability for applications assistance or the design of Buyers' products. Buyers are responsible for their products and applications using TI components. To minimize the risks associated with Buyers' products and applications, Buyers should provide adequate design and operating safeguards.

TI does not warrant or represent that any license, either express or implied, is granted under any patent right, copyright, mask work right, or other intellectual property right relating to any combination, machine, or process in which TI components or services are used. Information published by TI regarding third-party products or services does not constitute a license to use such products or services or a warranty or endorsement thereof. Use of such information may require a license from a third party under the patents or other intellectual property of the third party, or a license from TI under the patents or other intellectual property of TI.

Reproduction of significant portions of TI information in TI data books or data sheets is permissible only if reproduction is without alteration and is accompanied by all associated warranties, conditions, limitations, and notices. TI is not responsible or liable for such altered documentation. Information of third parties may be subject to additional restrictions.

Resale of TI components or services with statements different from or beyond the parameters stated by TI for that component or service voids all express and any implied warranties for the associated TI component or service and is an unfair and deceptive business practice. TI is not responsible or liable for any such statements.

Buyer acknowledges and agrees that it is solely responsible for compliance with all legal, regulatory and safety-related requirements concerning its products, and any use of TI components in its applications, notwithstanding any applications-related information or support that may be provided by TI. Buyer represents and agrees that it has all the necessary expertise to create and implement safeguards which anticipate dangerous consequences of failures, monitor failures and their consequences, lessen the likelihood of failures that might cause harm and take appropriate remedial actions. Buyer will fully indemnify TI and its representatives against any damages arising out of the use of any TI components in safety-critical applications.

In some cases, TI components may be promoted specifically to facilitate safety-related applications. With such components, TI's goal is to help enable customers to design and create their own end-product solutions that meet applicable functional safety standards and requirements. Nonetheless, such components are subject to these terms.

No TI components are authorized for use in FDA Class III (or similar life-critical medical equipment) unless authorized officers of the parties have executed a special agreement specifically governing such use.

Only those TI components which TI has specifically designated as military grade or "enhanced plastic" are designed and intended for use in military/aerospace applications or environments. Buyer acknowledges and agrees that any military or aerospace use of TI components which have **not** been so designated is solely at the Buyer's risk, and that Buyer is solely responsible for compliance with all legal and regulatory requirements in connection with such use.

TI has specifically designated certain components as meeting ISO/TS16949 requirements, mainly for automotive use. In any case of use of non-designated products, TI will not be responsible for any failure to meet ISO/TS16949.

Products

Audio	www.ti.com/audio
Amplifiers	amplifier.ti.com
Data Converters	dataconverter.ti.com
DLP® Products	www.dlp.com
DSP	dsp.ti.com
Clocks and Timers	www.ti.com/clocks
Interface	interface.ti.com
Logic	logic.ti.com
Power Mgmt	power.ti.com
Microcontrollers	microcontroller.ti.com
RFID	www.ti-rfid.com
OMAP Applications Processors	www.ti.com/omap
Wireless Connectivity	www.ti.com/wirelessconnectivity

Applications

Automotive and Transportation	www.ti.com/automotive
Communications and Telecom	www.ti.com/communications
Computers and Peripherals	www.ti.com/computers
Consumer Electronics	www.ti.com/consumer-apps
Energy and Lighting	www.ti.com/energy
Industrial	www.ti.com/industrial
Medical	www.ti.com/medical
Security	www.ti.com/security
Space, Avionics and Defense	www.ti.com/space-avionics-defense
Video and Imaging	www.ti.com/video

TI E2E Community

e2e.ti.com

Looking for pricing, stock, or lifecycle information?

Click below to explore more details on WIN SOURCE:

 [View AFE8220TPZPQ1](#) on WIN SOURCE

 [Texas Instruments](#) Information

Optimize Your Supply Chain with WIN SOURCE Solutions

-  Global Sourcing Solution
-  Obsolete Management
-  Cost Control Management
-  Shortage Management
-  Alternative Solution
-  Excess Inventory Management