



THE DATASHEET OF ADS7888SDBVT



ADS788x 10-Bit, 8-Bit, 1.25-MSPS, Micro-Power, Miniature SAR Analog-to-Digital Converters

1 Features

- 1.25-MHz Sample Rate Serial Device
- 10-Bit Resolution (ADS7887)
- 8-Bit Resolution (ADS7888)
- Zero Latency
- 25-MHz Serial Interface
- Supply Range: 2.35 V to 5.25 V
- Typical Power Dissipation at 1.25 MSPS:
 - 3.8 mW at 3-V V_{DD}
 - 8 mW at 5-V V_{DD}
- ± 0.35 LSB INL, DNL (ADS7887)
- ± 0.15 LSB INL, ± 0.1 LSB DNL (ADS7888)
- 61 dB SINAD, -84 dB THD (ADS7887)
- 49.5 dB SINAD, -67.5 dB THD (ADS7888)
- Unipolar Input Range: 0 V to V_{DD}
- Power-Down Current: 1 μ A
- Wide Input Bandwidth: 15 MHz at 3 dB
- 6-Pin SOT23 and SC70 Packages

2 Applications

- Base Band Converters in Radio Communication
- Motor Current and Bus Voltage Sensors in Digital Drives
- Optical Networking (DWDM, MEMS-Based Switching)
- Optical Sensors
- Battery-Powered Systems
- Medical Instrumentations
- High-Speed Data Acquisition Systems
- High-Speed Closed-Loop Systems

3 Description

The ADS7887 device is a 10-bit, 1.25-MSPS, analog-to-digital converter (ADC), and the ADS7888 device is a 8-bit, 1.25-MSPS ADC. These devices include a capacitor-based SAR A/D converter with inherent sample and hold. The serial interface in each device is controlled by the \overline{CS} and SCLK signals for glueless connections with microprocessors and DSPs. The input signal is sampled with the falling edge of \overline{CS} , and SCLK is used for conversion and serial data output.

The devices operate from a wide supply range from 2.35 V to 5.25 V. The low power consumption of the devices make them suitable for battery-powered applications. The devices also include a power-saving, power-down feature for when the devices are operated at lower conversion speeds.

The high level of the digital input to the device is not limited to device V_{DD} . This means the digital input can go as high as 5.25 V when device supply is 2.35 V. This feature is useful when digital signals are coming from other circuit with different supply levels. Also this relaxes restriction on power-up sequencing.

The ADS7887 and ADS7888 are available in 6-pin SOT-23 and SC70 packages and are specified for operation from -40°C to 125°C .

Device Information⁽¹⁾

PART NUMBER	PACKAGE	BODY SIZE (NOM)
ADS7887	SOT-23 (6)	2.90 mm x 1.60 mm
ADS7888	SC70 (6)	2.00 mm x 1.25 mm

(1) For all available packages, see the orderable addendum at the end of the data sheet.

Functional Block Diagram

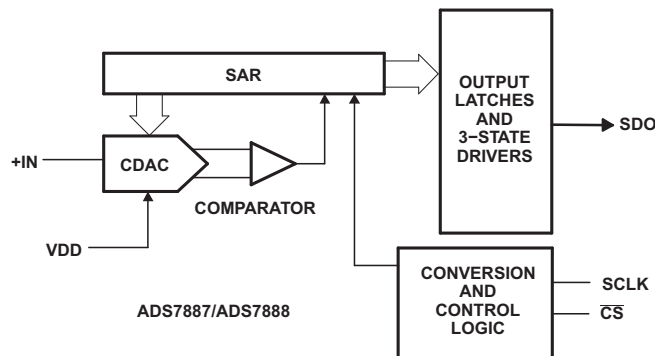

Copyright © 2016, Texas Instruments Incorporated



Table of Contents

1 Features	1	9.3 Feature Description	17
2 Applications	1	9.4 Device Functional Modes	18
3 Description	1	10 Application and Implementation	20
4 Revision History	2	10.1 Application Information	20
5 Companion Products	3	10.2 Typical Application	20
6 Device Comparison	4	11 Power Supply Recommendations	22
7 Pin Configuration and Functions	5	12 Layout	23
8 Specifications	6	12.1 Layout Guidelines	23
8.1 Absolute Maximum Ratings	6	12.2 Layout Example	23
8.2 ESD Ratings	6	13 Device and Documentation Support	24
8.3 Recommended Operating Conditions	6	13.1 Documentation Support	24
8.4 Thermal Information	6	13.2 Related Links	24
8.5 Electrical Characteristics – ADS7887	7	13.3 Receiving Notification of Documentation Updates	24
8.6 Electrical Characteristics – ADS7888	8	13.4 Community Resources	24
8.7 Timing Requirements	9	13.5 Trademarks	24
8.8 Typical Characteristics	10	13.6 Electrostatic Discharge Caution	24
9 Detailed Description	16	13.7 Glossary	24
9.1 Overview	16	14 Mechanical, Packaging, and Orderable Information	25
9.2 Functional Block Diagram	16		

4 Revision History

NOTE: Page numbers for previous revisions may differ from page numbers in the current version.

Changes from Original (June 2005) to Revision A	Page
• Added <i>ESD Ratings</i> table, <i>Feature Description</i> section, <i>Device Functional Modes</i> , <i>Application and Implementation</i> section, <i>Power Supply Recommendations</i> section, <i>Layout</i> section, <i>Device and Documentation Support</i> section, and <i>Mechanical, Packaging, and Orderable Information</i> section	1
• Changed <i>Thermal Information</i> table	6

5 Companion Products

PART NUMBER	NAME
SN74LVTH245A	3.3-V ABT Octal Bus Transceivers With 3-State Outputs
LMV761	Low Voltage, Precision Comparator with Push-Pull Output
TPS54418	2.95V to 6V Input, 4A Synchronous Step-Down SWIFT™ Converter
LMV339	Quad General Purpose Low-Voltage Comparators
TPS730	Low-Noise, High PSRR, RF 200-mA Low-Dropout Linear Regulators

6 Device Comparison

BIT	< 300 KSPS	300 KSPS – 1.25 MSPS
12-Bit	ADS7866 (1.2 V _{DD} to 3.6 V _{DD})	ADS7886 (2.35 V _{DD} to 5.25 V _{DD})
10-Bit	ADS7867 (1.2 V _{DD} to 3.6 V _{DD})	ADS7887 (2.35 V _{DD} to 5.25 V _{DD})
8-Bit	ADS7868 (1.2 V _{DD} to 3.6 V _{DD})	ADS7888 (2.35 V _{DD} to 5.25 V _{DD})

7 Pin Configuration and Functions

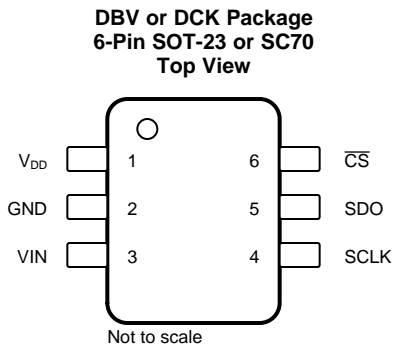

Pin Functions

PIN		I/O	DESCRIPTION
NO.	NAME		
1	V _{DD}	—	Power supply input also acts like a reference voltage to ADC.
2	GND	—	Ground for power supply, all analog and digital signals are referred with respect to this pin.
3	VIN	I	Analog signal input
4	SCLK	I	Serial clock
5	SDO	O	Serial data out
6	$\overline{\text{CS}}$	I	Chip select signal, active low

8 Specifications

8.1 Absolute Maximum Ratings

over operating free-air temperature range (unless otherwise noted)⁽¹⁾

	MIN	MAX	UNIT
+IN to AGND	−0.3	$V_{DD} + 0.3$	V
+V _{DD} to AGND	−0.3	7	V
Digital input voltage to GND	−0.3	7	V
Digital output to GND	−0.3	$V_{DD} + 0.3$	V
Power dissipation, both packages	$(T_{J(MAX)} - T_A) / R_{\theta JA}$		
Lead temperature, soldering	Vapor phase (60 s)		°C
	Infrared (15 s)		
Junction temperature, $T_{J(MAX)}$	150		°C
Storage temperature, T_{stg}	−65	150	°C

- (1) Stresses beyond those listed under *Absolute Maximum Ratings* may cause permanent damage to the device. These are stress ratings only, which do not imply functional operation of the device at these or any other conditions beyond those indicated under *Recommended Operating Conditions*. Exposure to absolute-maximum-rated conditions for extended periods may affect device reliability.

8.2 ESD Ratings

	VALUE	UNIT
V _(ESD) Electrostatic discharge	Human-body model (HBM), per ANSI/ESDA/JEDEC JS-001 ⁽¹⁾	±2000
	Charged-device model (CDM), per JEDEC specification JESD22-C101 ⁽²⁾	±500

- (1) JEDEC document JEP155 states that 500-V HBM allows safe manufacturing with a standard ESD control process.
 (2) JEDEC document JEP157 states that 250-V CDM allows safe manufacturing with a standard ESD control process.

8.3 Recommended Operating Conditions

over operating free-air temperature range (unless otherwise noted)

	MIN	MAX	UNIT
T _A Operating temperature	−40	125	°C

8.4 Thermal Information

THERMAL METRIC ⁽¹⁾	ADS7887, ADS7888		UNIT
	DBV (SOT-23)	DCK (SC70)	
	6 PINS	6 PINS	
R _{θJA} Junction-to-ambient thermal resistance	114.9	150.7	°C/W
R _{θJC(top)} Junction-to-case (top) thermal resistance	56.6	62.3	°C/W
R _{θJB} Junction-to-board thermal resistance	36.5	43	°C/W
ψ _{JT} Junction-to-top characterization parameter	5.8	1.8	°C/W
ψ _{JB} Junction-to-board characterization parameter	36.2	42.4	°C/W
R _{θJC(bot)} Junction-to-case (bottom) thermal resistance	—	—	°C/W

- (1) For more information about traditional and new thermal metrics, see the [Semiconductor and IC Package Thermal Metrics](#) application report.

8.5 Electrical Characteristics – ADS7887

 $+V_{DD} = 2.35\text{ V to }5.25\text{ V}$, $T_A = -40^\circ\text{C to }125^\circ\text{C}$, and $f_{\text{sample}} = 1.25\text{ MHz}$ (unless otherwise noted)

PARAMETER		TEST CONDITIONS	MIN	TYP	MAX	UNIT
ANALOG INPUT						
	Full-scale input voltage span ⁽¹⁾		0		V_{DD}	V
	Absolute input voltage range	+IN	-0.2		$V_{DD} + 0.2$	V
C_i	Input capacitance ⁽²⁾			21		pF
$I_{\text{ilk}}g$	Input leakage current	$T_A = 125^\circ\text{C}$		40		nA
SYSTEM PERFORMANCE						
	Resolution			10		Bits
	No missing codes		10			Bits
INL	Integral nonlinearity		-0.75	± 0.35	0.75	LSB ⁽³⁾
DNL	Differential nonlinearity		-0.5	± 0.35	0.5	LSB
E_O	Offset error ⁽⁴⁾⁽⁵⁾⁽⁶⁾		-1.5	± 0.5	1.5	LSB
E_G	Gain error ⁽⁵⁾		-1	± 0.5	1	LSB
SAMPLING DYNAMICS						
	Conversion time	25-MHz SCLK	530	560		ns
	Acquisition time		260			ns
	Maximum throughput rate	25-MHz SCLK			1.25	MHz
	Aperture delay			5		ns
	Step Response			160		ns
	Overvoltage recovery			160		ns
DYNAMIC CHARACTERISTICS						
THD	Total harmonic distortion ⁽⁷⁾	100 kHz		-84	-72	dB
SINAD	Signal-to-noise and distortion	100 kHz	60.5	61		dB
SFDR	Spurious free dynamic range	100 kHz	73	81		dB
	Full power bandwidth	At -3 dB		15		MHz
DIGITAL INPUT/OUTPUT						
V_{IH}	High-level input voltage	$V_{DD} = 2.35\text{ V to }5.25\text{ V}$	$V_{DD} - 0.4$		5.25	V
V_{IL}	Low-level input voltage	$V_{DD} = 5\text{ V}$			0.8	V
		$V_{DD} = 3\text{ V}$			0.4	
V_{OH}	High-level output voltage	At $I_{\text{source}} = 200\ \mu\text{A}$	$V_{DD} - 0.2$			V
V_{OL}	Low-level output voltage	At $I_{\text{sink}} = 200\ \mu\text{A}$			0.4	
POWER SUPPLY REQUIREMENTS						
$+V_{DD}$	Supply voltage		2.35	3.3	5.25	V
	Supply current (normal mode)	At $V_{DD} = 2.35\text{ V to }5.25\text{ V}$, 1.25-MHz throughput			2	mA
		At $V_{DD} = 2.35\text{ V to }5.25\text{ V}$, static state			1.5	
	Power-down state supply current	SCLK off			1	μA
		SCLK on (25 MHz)			200	
	Power dissipation at 1.25-MHz throughput	$V_{DD} = 5\text{ V}$		8	10	mW
		$V_{DD} = 3\text{ V}$		3.8	6	
	Power dissipation in static state	$V_{DD} = 5\text{ V}$		5.5	7.5	mW
		$V_{DD} = 3\text{ V}$		3	4.5	
	Power-down time				0.1	μs

(1) Ideal input span; does not include gain or offset error.

(2) Refer [Figure 31](#) for details on sampling circuit

(3) LSB means least significant bit

(4) Measured relative to an ideal full-scale input

(5) Offset error and gain error ensured by characterization.

(6) First transition of 000H to 001H at $0.5 \times (V_{\text{ref}}/2^{10})$

(7) Calculated on the first nine harmonics of the input frequency

Electrical Characteristics – ADS7887 (continued)

 $+V_{DD} = 2.35 \text{ V to } 5.25 \text{ V}$, $T_A = -40^\circ\text{C to } 125^\circ\text{C}$, and $f_{\text{sample}} = 1.25 \text{ MHz}$ (unless otherwise noted)

PARAMETER	TEST CONDITIONS	MIN	TYP	MAX	UNIT
Power-up time				0.8	μs
Invalid conversions after power up				1	

8.6 Electrical Characteristics – ADS7888

 $+V_{DD} = 2.35 \text{ V to } 5.25 \text{ V}$, $T_A = -40^\circ\text{C to } 125^\circ\text{C}$, and $f_{\text{sample}} = 1.25 \text{ MHz}$ (unless otherwise noted)

PARAMETER	TEST CONDITIONS	MIN	TYP	MAX	UNIT
ANALOG INPUT					
Full-scale input voltage span ⁽¹⁾		0		V_{DD}	V
Absolute input voltage range	+IN	-0.2		$V_{DD} + 0.2$	V
C_i Input capacitance ⁽²⁾			21		pF
I_{ilkq} Input leakage current	$T_A = 125^\circ\text{C}$		40		nA
SYSTEM PERFORMANCE					
Resolution			8		Bits
No missing codes		8			Bits
INL Integral nonlinearity		-0.3	± 0.15	0.3	LSB ⁽³⁾
DNL Differential nonlinearity		-0.3	± 0.1	0.3	LSB
E_O Offset error ^{(4) (5) (6)}		-0.5	± 0.15	0.5	LSB
E_G Gain error ⁽⁵⁾		-0.5	± 0.15	0.5	LSB
SAMPLING DYNAMICS					
Conversion time	25-MHz SCLK	450	480		ns
Acquisition time	1.5 MSPS mode, see Figure 34	206			ns
Maximum throughput rate	25-MHz SCLK			1.25	MHz
Aperture delay			5		ns
Step Response			160		ns
Overvoltage recovery			160		ns
DYNAMIC CHARACTERISTICS					
THD Total harmonic distortion ⁽⁷⁾	100 kHz		-67.5	-65	dB
SINAD Signal-to-noise and distortion	100 kHz	49	49.5		dB
SFDR Spurious free dynamic range	100 kHz	65	77		dB
Full power bandwidth	At -3 dB		15		MHz
DIGITAL INPUT/OUTPUT					
V_{IH} High-level input voltage	$V_{DD} = 2.35 \text{ V to } 5.25 \text{ V}$	$V_{DD} - 0.4$		5.25	V
V_{IL} Low-level input voltage	$V_{DD} = 5 \text{ V}$			0.8	V
	$V_{DD} = 3 \text{ V}$			0.4	
V_{OH} High-level output voltage	At $I_{\text{source}} = 200 \mu\text{A}$	$V_{DD} - 0.2$			V
V_{OL} Low-level output voltage	At $I_{\text{sink}} = 200 \mu\text{A}$			0.4	
POWER SUPPLY REQUIREMENTS					
$+V_{DD}$ Supply voltage		2.35	3.3	5.25	V
Supply current (normal mode)	At $V_{DD} = 2.35 \text{ V to } 5.25 \text{ V}$, 1.25-MHz throughput			2	mA
	At $V_{DD} = 2.35 \text{ V to } 5.25 \text{ V}$, static state			1.5	

- (1) Ideal input span; does not include gain or offset error.
- (2) Refer [Figure 31](#) for details on sampling circuit
- (3) LSB means least significant bit
- (4) Measured relative to an ideal full-scale input
- (5) Offset error and gain error ensured by characterization.
- (6) First transition of 000H to 001H at $(V_{\text{ref}}/2^8)$
- (7) Calculated on the first nine harmonics of the input frequency

Electrical Characteristics – ADS7888 (continued)

 $+V_{DD} = 2.35\text{ V to }5.25\text{ V}$, $T_A = -40^\circ\text{C to }125^\circ\text{C}$, and $f_{\text{sample}} = 1.25\text{ MHz}$ (unless otherwise noted)

PARAMETER	TEST CONDITIONS	MIN	TYP	MAX	UNIT
Power-down state supply current	SCLK off			1	μA
	SCLK on (25 MHz)			200	
Power dissipation at 1.25 MHz throughput	$V_{DD} = 5\text{ V}$		8	10	mW
	$V_{DD} = 3\text{ V}$		3.8	6	
Power dissipation in static state	$V_{DD} = 5\text{ V}$		5.5	7.5	mW
	$V_{DD} = 3\text{ V}$		3	4.5	
Power-down time				0.1	μs
Power-up time				0.8	μs
Invalid conversions after power up				1	

8.7 Timing Requirements

All specifications typical at $T_A = -40^\circ\text{C to }125^\circ\text{C}$ and $V_{DD} = 2.35\text{ V to }5.25\text{ V}$ (unless otherwise noted; see [Figure 32](#))

PARAMETER	TEST CONDITIONS ⁽¹⁾	MIN	TYP	MAX	UNIT
t_{conv} Conversion time	ADS7887	$V_{DD} = 3\text{ V}$		$14 \times t_{\text{SCLK}}$	ns
		$V_{DD} = 5\text{ V}$		$14 \times t_{\text{SCLK}}$	
	ADS7888	$V_{DD} = 3\text{ V}$		$12 \times t_{\text{SCLK}}$	
		$V_{DD} = 5\text{ V}$		$12 \times t_{\text{SCLK}}$	
t_q Quiet time	Minimum time required from bus 3-state to start of next conversion	$V_{DD} = 3\text{ V}$	40		ns
		$V_{DD} = 5\text{ V}$	40		
t_{d1} Delay time	$\overline{\text{CS}}$ low to first data (0) out	$V_{DD} = 3\text{ V}$		15 25	ns
		$V_{DD} = 5\text{ V}$		13 25	
$t_{\text{su}1}$ Setup time	$\overline{\text{CS}}$ low to SCLK low	$V_{DD} = 3\text{ V}$	10		ns
		$V_{DD} = 5\text{ V}$	10		
t_{d2} Delay time	SCLK falling to SDO	$V_{DD} = 3\text{ V}$		15 25	ns
		$V_{DD} = 5\text{ V}$		13 25	
t_{h1} Hold time	SCLK falling to data valid (with 50-pF load)	$V_{DD} < 3\text{ V}$	7		ns
		$V_{DD} > 5\text{ V}$	5.5		
t_{d3} Delay time	16th SCLK falling edge to SDO 3-state	$V_{DD} = 3\text{ V}$		10 25	ns
		$V_{DD} = 5\text{ V}$		8 20	
t_{w1} Pulse duration	$\overline{\text{CS}}$	$V_{DD} = 3\text{ V}$	25	40	ns
		$V_{DD} = 5\text{ V}$	25	40	
t_{d4} Delay time	$\overline{\text{CS}}$ high to SDO 3-state, see Figure 34	$V_{DD} = 3\text{ V}$		17 30	ns
		$V_{DD} = 5\text{ V}$		15 25	
t_{wH} Pulse duration	SCLK high	$V_{DD} = 3\text{ V}$	$0.4 \times t_{\text{SCLK}}$		ns
		$V_{DD} = 5\text{ V}$	$0.4 \times t_{\text{SCLK}}$		
t_{wL} Pulse duration	SCLK low	$V_{DD} = 3\text{ V}$	$0.4 \times t_{\text{SCLK}}$		ns
		$V_{DD} = 5\text{ V}$	$0.4 \times t_{\text{SCLK}}$		
Frequency	SCLK	$V_{DD} = 3\text{ V}$		25	MHz
		$V_{DD} = 5\text{ V}$		25	
t_{d5} Delay time	Second falling edge of clock and $\overline{\text{CS}}$ to enter in power down (use min spec not to accidentally enter in power down, see Figure 35)	$V_{DD} = 3\text{ V}$	-2	5	ns
		$V_{DD} = 5\text{ V}$	-2	5	
t_{d6} Delay time	$\overline{\text{CS}}$ and 10th falling edge of clock to enter in power down (use max spec not to accidentally enter in power down, see Figure 35)	$V_{DD} = 3\text{ V}$	2	-5	ns
		$V_{DD} = 5\text{ V}$	2	-5	

(1) 3-V Specifications apply from 2.35 V to 3.6 V, and 5-V specifications apply from 4.75 V to 5.25 V.

8.8 Typical Characteristics

8.8.1 ADS7887 and ADS7888

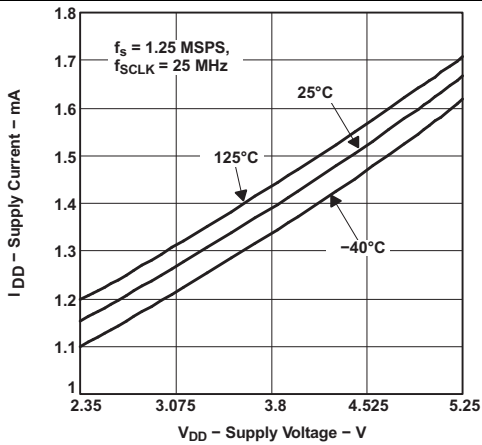

Figure 1. Supply Current vs Supply Voltage

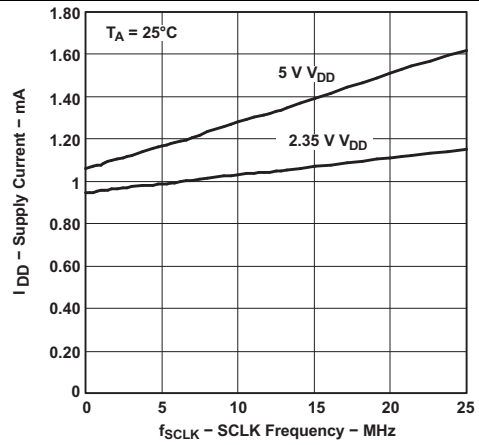

Figure 2. Supply Current vs SCLK Frequency

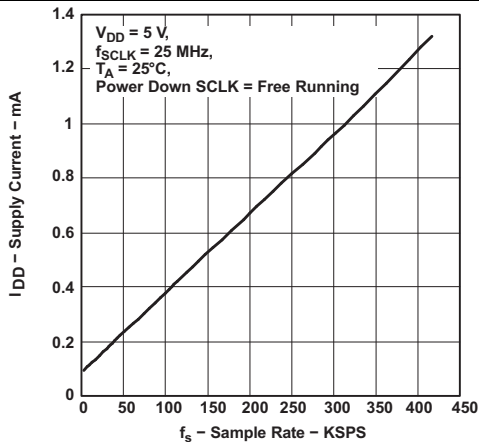

Figure 3. Supply Current vs Sample Rate

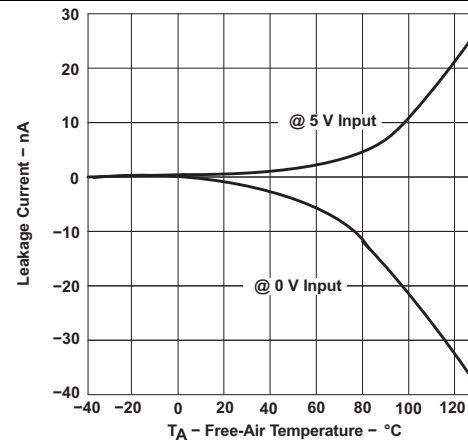

Figure 4. Analog Input Leakage Current vs Free-Air Temperature

8.8.2 ADS7887 Only

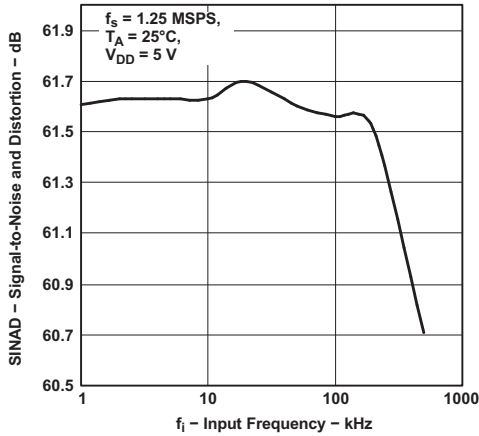

Figure 5. Signal-to-Noise and Distortion vs Input Frequency

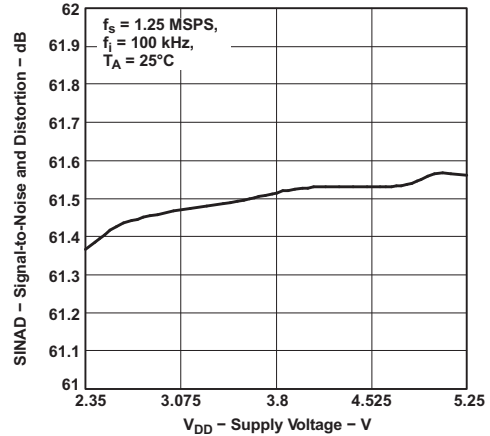

Figure 6. Signal-to-Noise and Distortion vs Supply Voltage

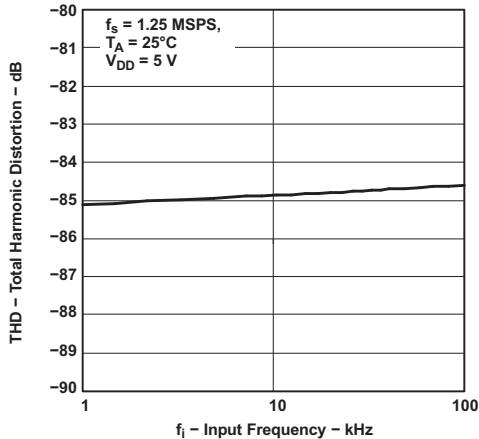

Figure 7. Total Harmonic Distortion vs Input Frequency

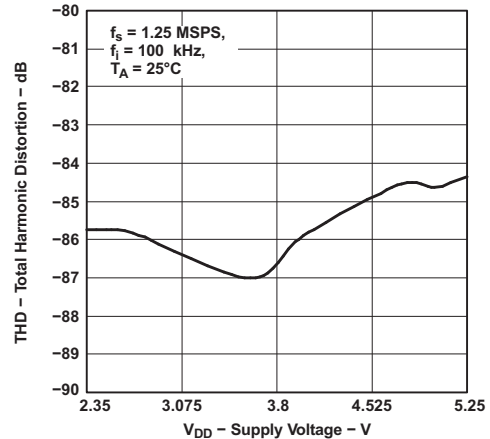

Figure 8. Total Harmonic Distortion vs Supply Voltage

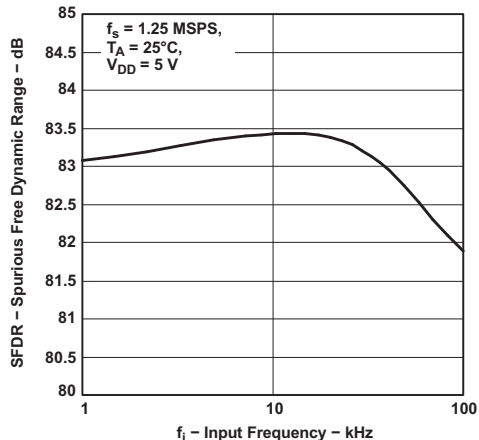

Figure 9. Spurious Free Dynamic Range vs Input Frequency

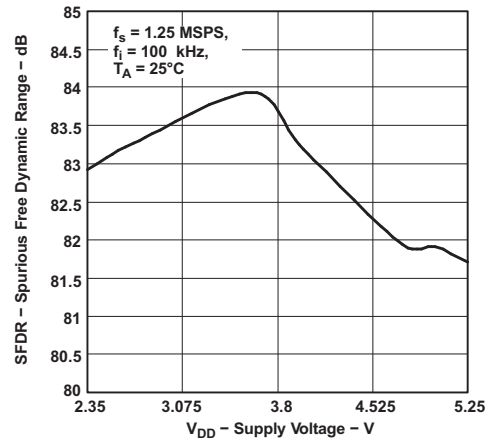

Figure 10. Spurious Free Dynamic Range vs Supply Voltage

ADS7887 Only (continued)

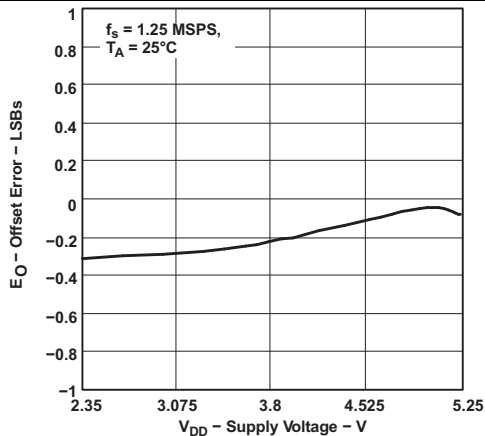

Figure 11. Offset Error vs Supply Voltage

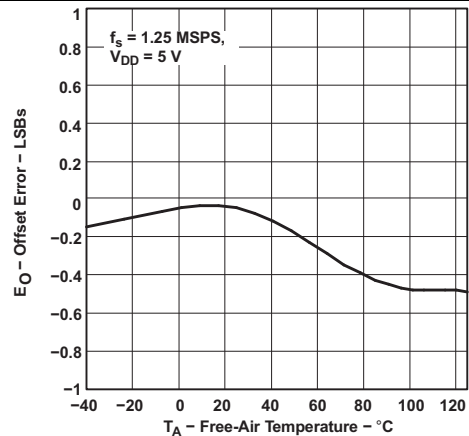

Figure 12. Offset Error vs Free-Air Temperature

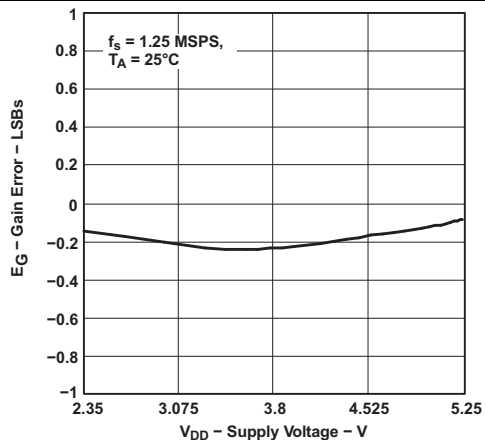

Figure 13. Gain Error vs Supply Voltage

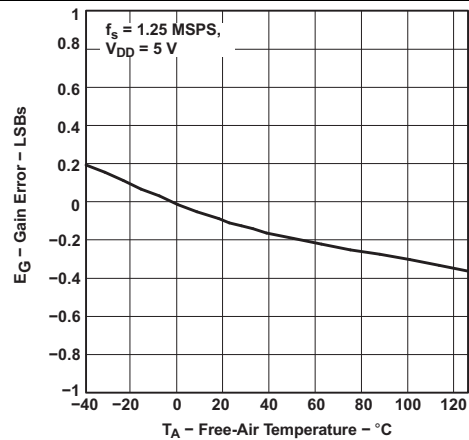

Figure 14. Gain Error vs Free-Air Temperature

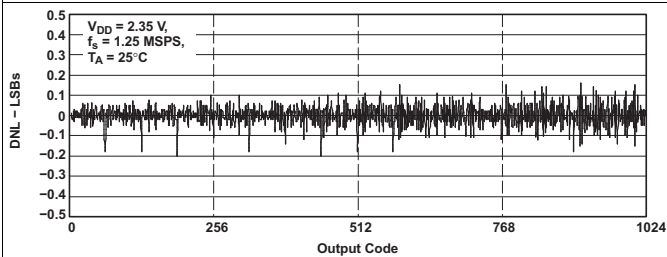

Figure 15. DNL

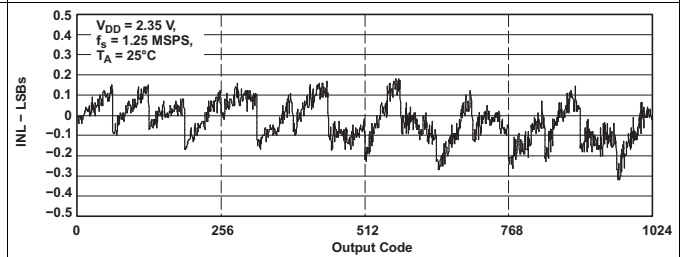
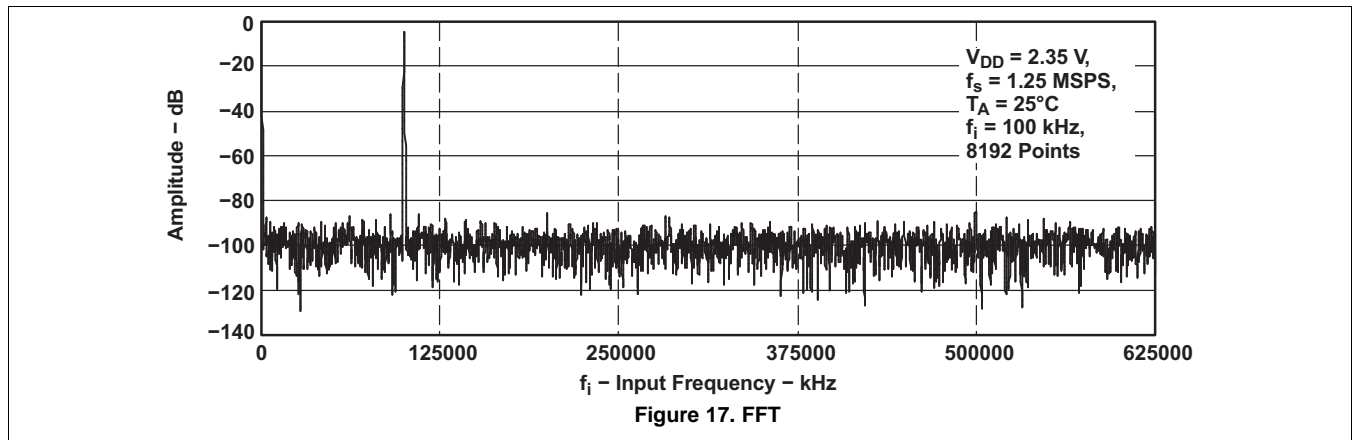
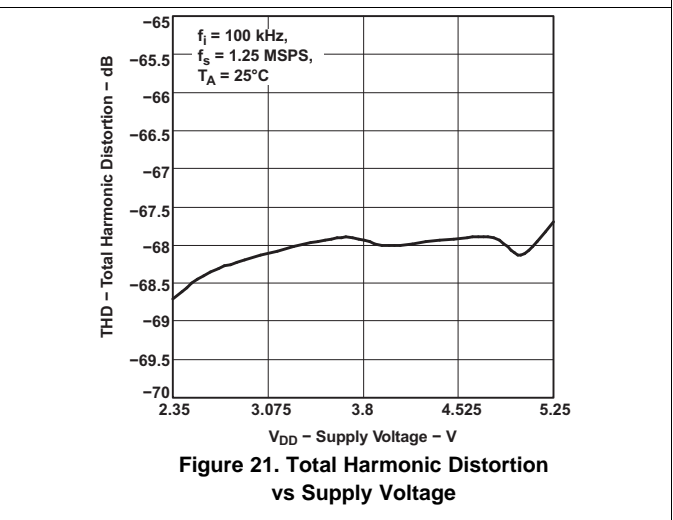
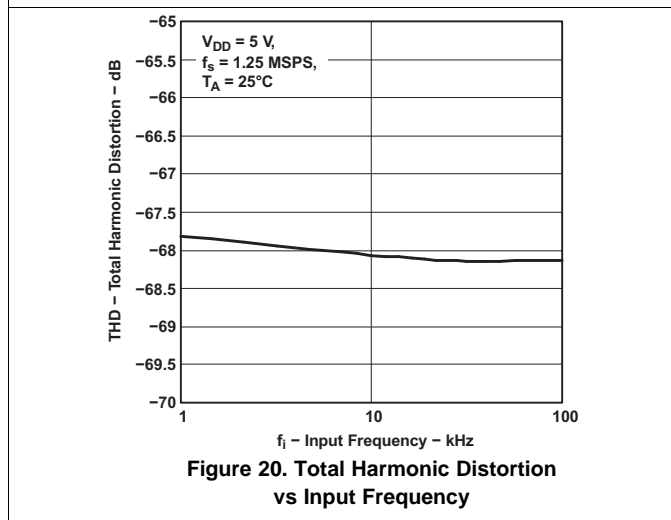
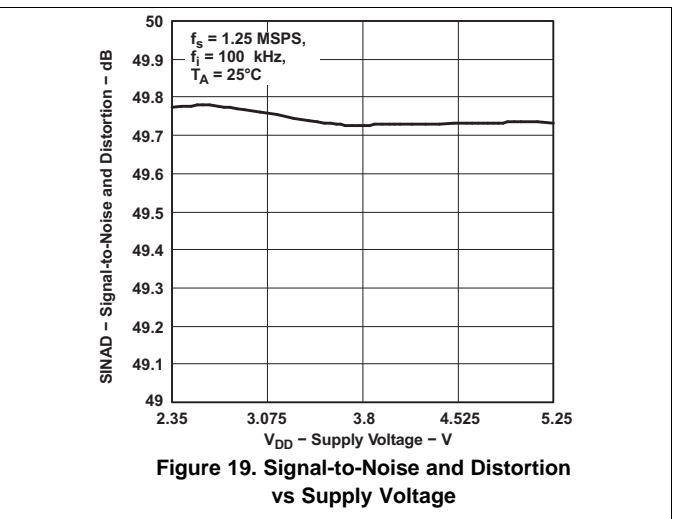
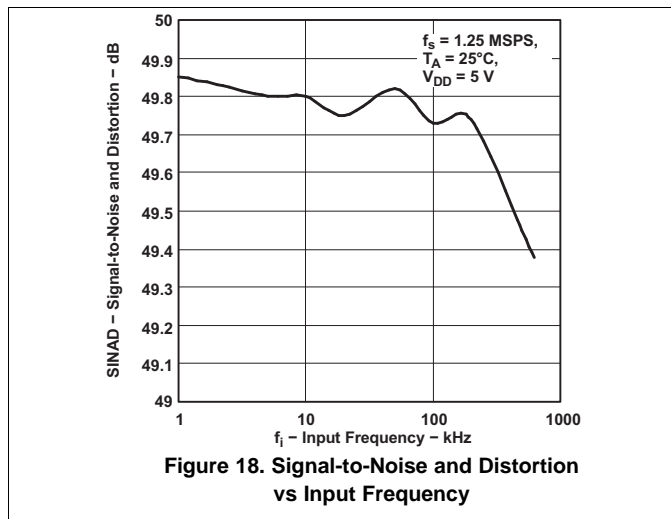

Figure 16. INL

ADS7887 Only (continued)



8.8.3 ADS7888 Only



ADS7888 Only (continued)

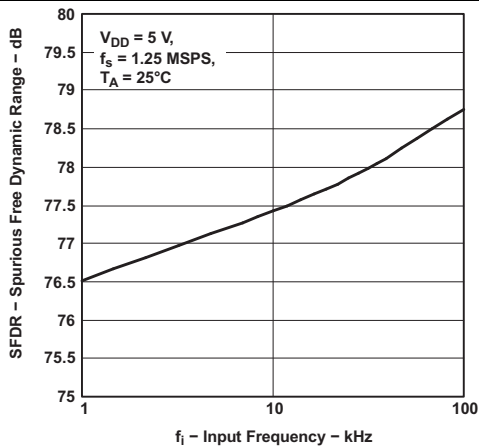

Figure 22. Spurious Free Dynamic Range vs Input Frequency

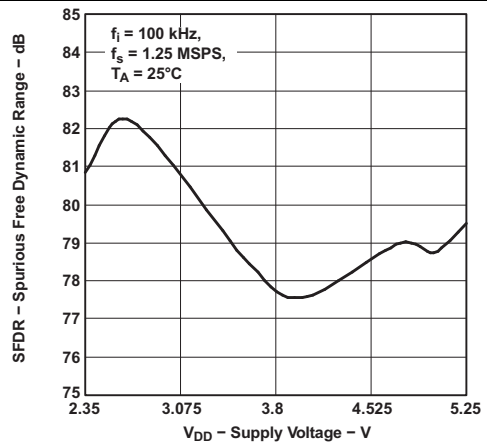

Figure 23. Spurious Free Dynamic Range vs Supply Voltage

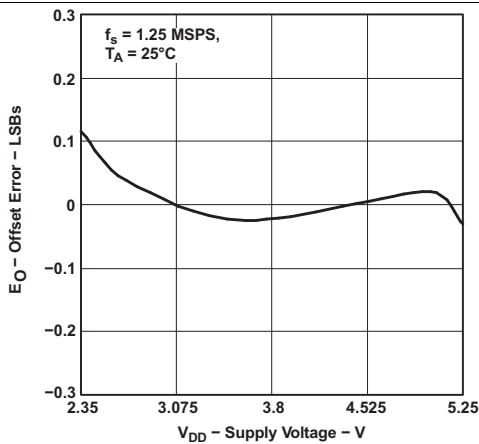

Figure 24. Offset Error vs Supply Voltage

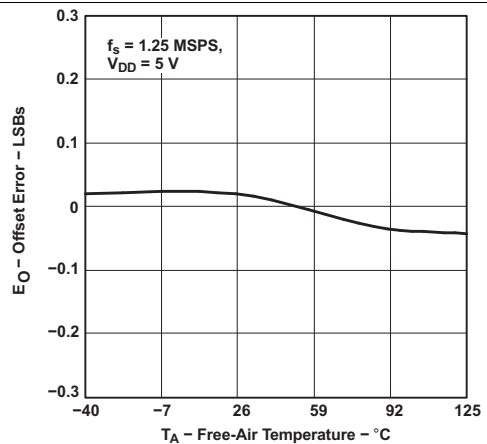

Figure 25. Offset Error vs Free-Air Temperature

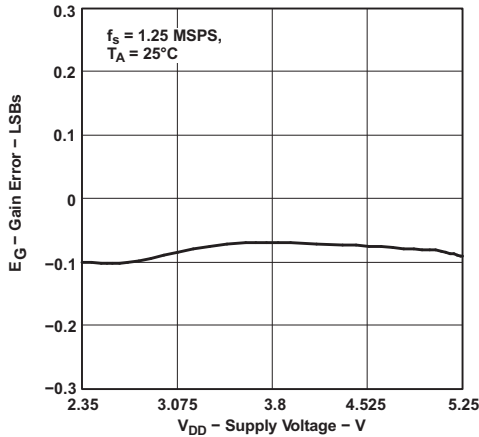

Figure 26. Gain Error vs Supply Voltage

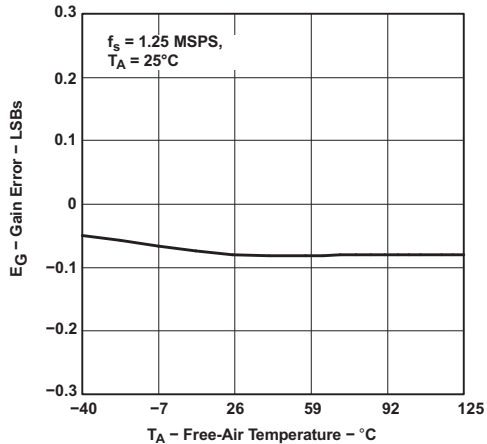
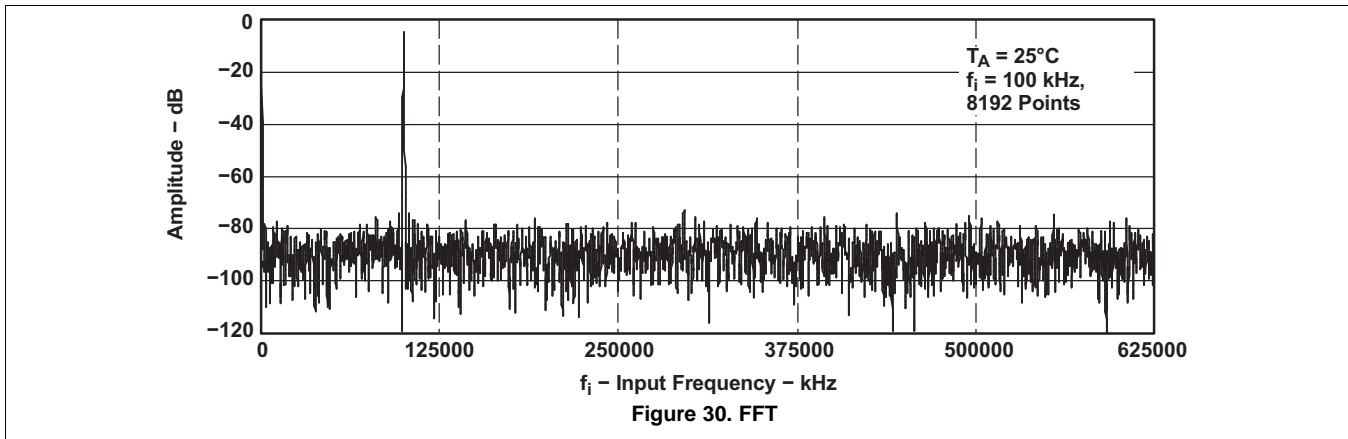
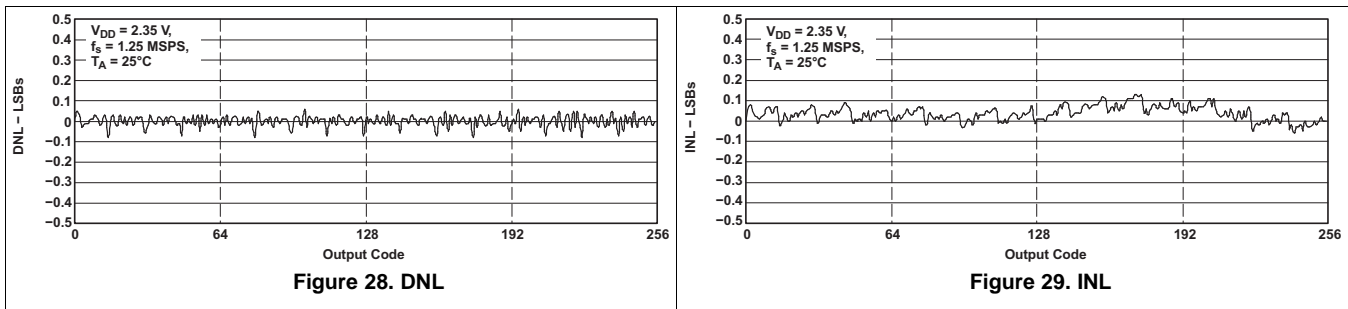

Figure 27. Gain Error vs Free-Air Temperature

ADS7888 Only (continued)



9 Detailed Description

9.1 Overview

The ADS788x devices are ADC converters. The serial interface in each device is controlled by the $\overline{\text{CS}}$ and SCLK signals for easy interface with microprocessors and DSPs. The input signal is sampled with the falling edge of $\overline{\text{CS}}$, and SCLK is used for conversion and serial data output. They both operate in a wide supply range from 2.35 V to 5.25 V and low power consumption makes them suitable for battery-powered applications.

9.1.1 Driving the VIN and V_{DD} Pins of the ADS7887 and ADS7888

The VIN input to the ADS7887 and ADS7888 must be driven with a low impedance source. In most cases additional buffers are not required. In cases where the source impedance exceeds 200 Ω, using a buffer would help achieve the rated performance of the converter. The THS4031 is a good choice for the driver amplifier buffer.

The reference voltage for the ADS7887 and ADS7888 A/D converters are derived from the supply voltage internally. The devices offer limited low-pass filtering functionality on-chip. The supply to these converters must be driven with a low impedance source and must be decoupled to the ground. A 1-μF storage capacitor and a 10-nF decoupling capacitor must be placed close to the device. Wide, low impedance traces must be used to connect the capacitor to the pins of the device. The ADS7887 and ADS7888 draw very little current from the supply lines. The supply line can be driven by either:

- Directly from the system supply.
- A reference output from a low drift and low dropout reference voltage generator like REF3030 or REF3130. The ADS7887 and ADS7888 can operate off a wide range of supply voltages. The actual choice of the reference voltage generator would depend upon the system. [Figure 41](#) shows one possible application circuit.
- A low-pass filtered version of the system supply followed by a buffer like the zero-drift OPA735 can also be used in cases where the system power supply is noisy. Take care to ensure that the voltage at the V_{DD} input does not exceed 7 V (especially during power up) to avoid damage to the converter. This can be done easily using single-supply CMOS amplifiers like the OPA735. [Figure 42](#) shows one possible application circuit.

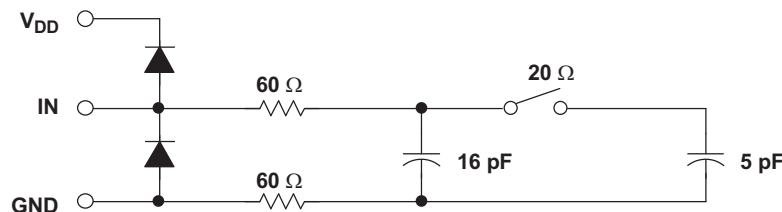
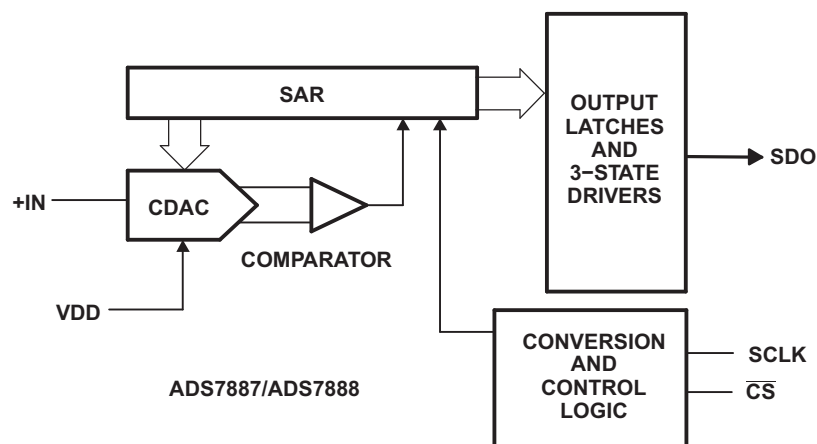

Figure 31. Typical Equivalent Sampling Circuit

9.2 Functional Block Diagram



Copyright © 2016, Texas Instruments Incorporated

9.3 Feature Description

9.3.1 ADS7887 Operation

The cycle begins with the falling edge of \overline{CS} . This point is indicated as a in Figure 32. With the falling edge of \overline{CS} , the input signal is sampled and the conversion process is initiated. The device outputs data while the conversion is in progress. The data word contains 4 leading zeros, followed by 10-bit data in MSB first format and padded by 2 lagging zeros.

The falling edge of \overline{CS} clocks out the first zero, and a zero is clocked out on every falling edge of the clock until the third edge. Data is in MSB first format with the MSB being clocked out on the 4th falling edge. Data is padded with two lagging zeros as shown in Figure 32. On the 16th falling edge of SCLK, SDO goes to the 3-state condition. The conversion ends on the 14th falling edge of SCLK. The device enters the acquisition phase on the first rising edge of SCLK after the 13th falling edge. This point is indicated by b in Figure 32.

\overline{CS} can be asserted (pulled high) after 16 clocks have elapsed. It is necessary not to start the next conversion by pulling \overline{CS} low until the end of the quiet time (t_q) after SDO goes to 3-state. To continue normal operation, it is necessary that \overline{CS} is not pulled high until point b. Without this, the device does not enter the acquisition phase and no valid data is available in the next cycle (refer to *Power-Down Mode* for more details). \overline{CS} going high any time after the conversion start aborts the ongoing conversion and SDO goes to 3-state.

The high level of the digital input to the device is not limited to device V_{DD} . This means the digital input can go as high as 5.25 V when the device supply is 2.35 V. This feature is useful when digital signals are coming from another circuit with different supply levels. Also, this relaxes the restriction on power-up sequencing. However, the digital output levels (V_{OH} and V_{OL}) are governed by V_{DD} as listed in *Specifications*.

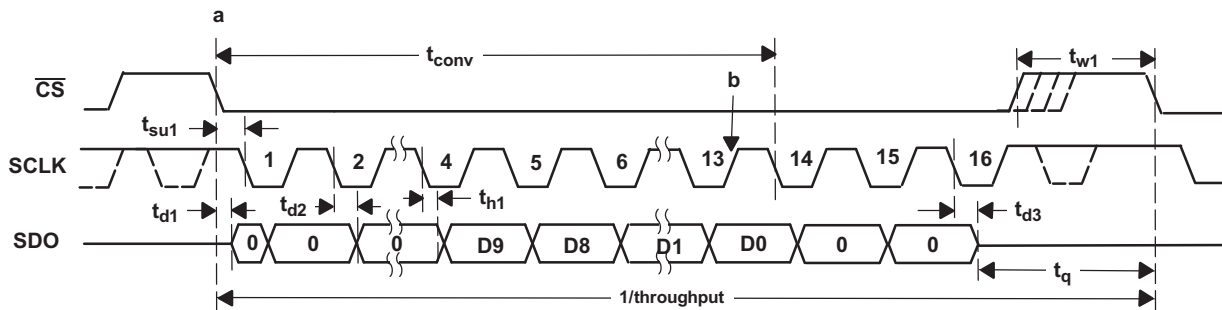

Figure 32. ADS7887 Interface Timing Diagram

9.3.2 ADS7888 Operation

The cycle begins with the falling edge of \overline{CS} . This point is indicated as a in Figure 33. With the falling edge of \overline{CS} , the input signal is sampled and the conversion process is initiated. The device outputs data while the conversion is in progress. The data word contains 4 leading zeros, followed by 8-bit data in MSB first format and padded by 4 lagging zeros.

The falling edge of \overline{CS} clocks out the first zero, and a zero is clocked out on every falling edge of the clock until the third edge. Data is in MSB first format with the MSB being clocked out on the 4th falling edge. Data is padded with four lagging zeros as shown in Figure 33. On the 16th falling edge of SCLK, SDO goes to the 3-state condition. The conversion ends on the 12th falling edge of SCLK. The device enters the acquisition phase on the first rising edge of SCLK after the 11th falling edge. This point is indicated by b in Figure 33.

\overline{CS} can be asserted (pulled high) after 16 clocks have elapsed. It is necessary not to start the next conversion by pulling \overline{CS} low until the end of the quiet time (t_q) after SDO goes to 3-state. To continue normal operation, it is necessary that \overline{CS} is not pulled high until point b. Without this, the device does not enter the acquisition phase and no valid data is available in the next cycle (refer to *Power-Down Mode* for more details). \overline{CS} going high any time after the conversion start aborts the ongoing conversion and SDO goes to 3-state.

The high level of the digital input to the device is not limited to device V_{DD} . This means the digital input can go as high as 5.25 V when the device supply is 2.35 V. This feature is useful when digital signals are coming from another circuit with different supply levels. Also, this relaxes the restriction on power-up sequencing. However, the digital output levels (V_{OH} and V_{OL}) are governed by V_{DD} as listed in *Specifications*.

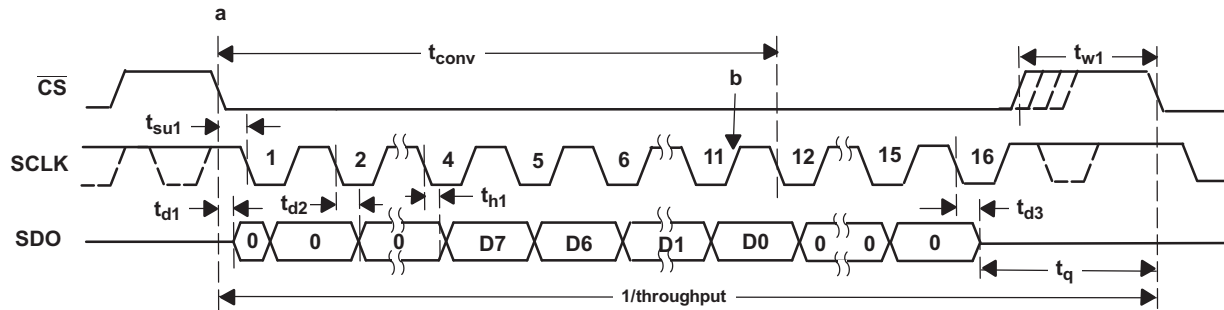
Feature Description (continued)

Figure 33. ADS7888 Interface Timing Diagram

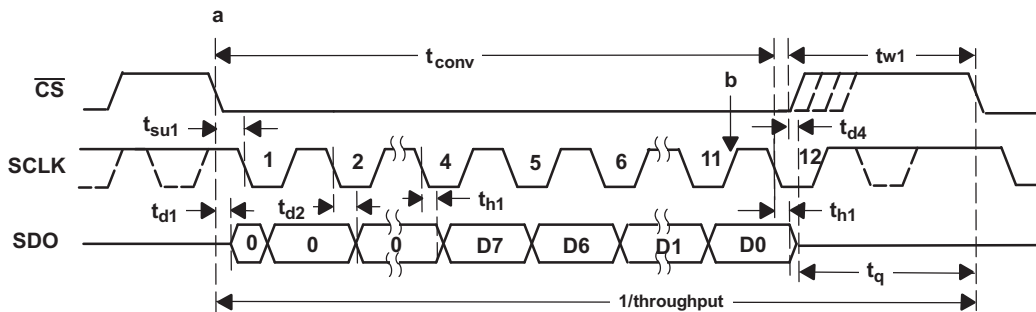
As shown in [Figure 34](#), the ADS7888 can achieve 1.5-MSPS throughput. \overline{CS} can be pulled high after the 12th falling edge (with a 25-MHz SCLK). SDO goes to 3-state after the LSB (as \overline{CS} is high). \overline{CS} can be pulled low at the end of the quiet time (t_q) after SDO goes to 3-state.

Figure 34. ADS7888 Interface Timing Diagram, Data Transfer With 12-Clock Frame
9.4 Device Functional Modes
9.4.1 Power-Down Mode

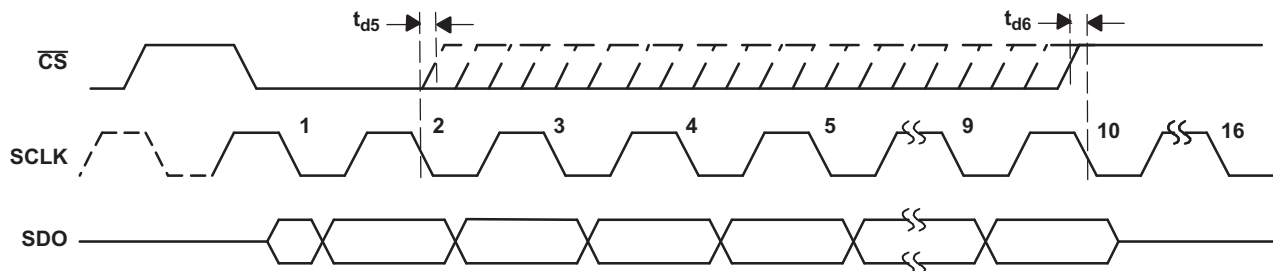
The device enters power-down mode if \overline{CS} goes high anytime after the 2nd SCLK falling edge to before the 10th SCLK falling edge. Ongoing conversion stops and SDO goes to 3-state under this power-down condition as shown in [Figure 35](#).

Figure 35. Entering Power-Down Mode

A dummy cycle with \overline{CS} low for more than 10 SCLK falling edges brings the device out of power-down mode. For the device to come to the fully powered-up condition it takes 0.8 μ s. \overline{CS} can be pulled high any time after the 10th falling edge as shown in [Figure 36](#). It is not necessary to continue until the 16th clock if the next conversion starts 0.8 μ s after \overline{CS} going low of the dummy cycle and the quiet time (t_q) condition is met.

Device Functional Modes (continued)

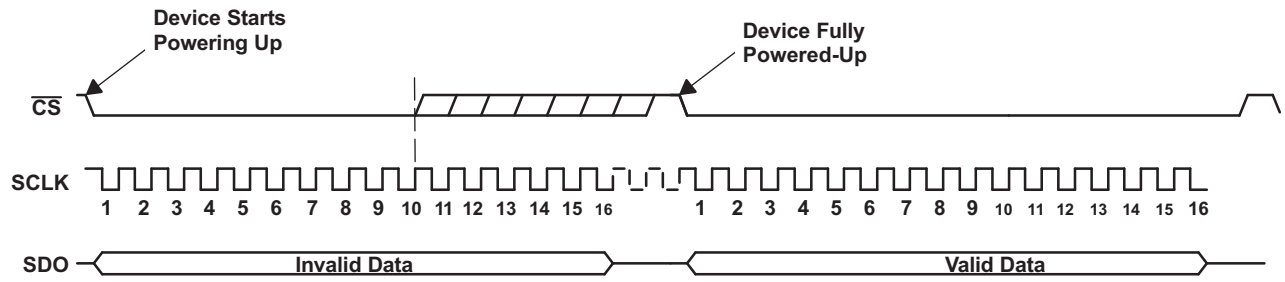

Figure 36. Exiting Power-Down Mode

10 Application and Implementation

NOTE

Information in the following applications sections is not part of the TI component specification, and TI does not warrant its accuracy or completeness. TI's customers are responsible for determining suitability of components for their purposes. Customers should validate and test their design implementation to confirm system functionality.

10.1 Application Information

The primary circuits required to maximize the performance of a high-precision, the successive approximation register (SAR) and analog-to-digital converter (ADC), are the input driver and the reference driver circuits. This section details some general principles for designing the input driver circuit, references the driver circuit, and provides some application circuits designed for the ADS7887 and ADS7888.

10.2 Typical Application

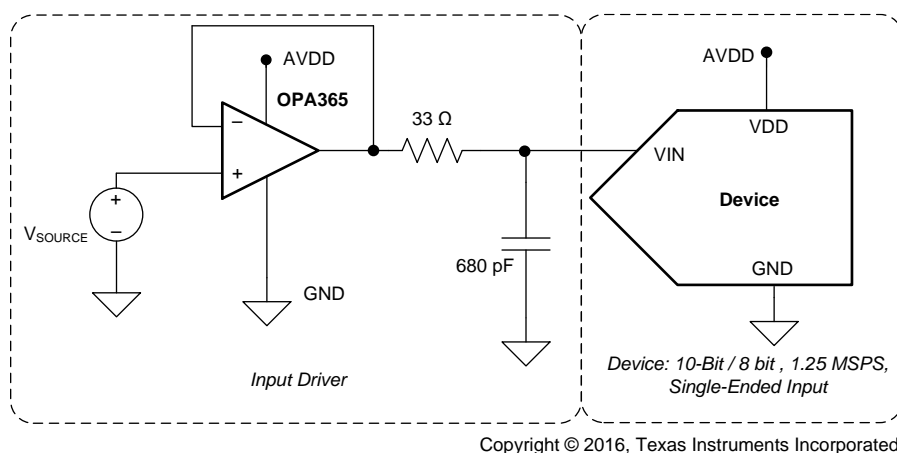

Figure 37. Typical Data Acquisition (DAQ) Circuit: Single-Supply DAQ

10.2.1 Design Requirements

The goal of this application is to design a single-supply digital acquisition (DAQ) circuit based on the ADS7887 with SNR greater than 61 dB and THD less than -84 dB for input frequencies of 2 kHz to 100 kHz at a throughput of 1.25 MSPS.

10.2.2 Detailed Design Procedure

To achieve a SINAD of 61 dB, the operational amplifier must have high bandwidth to settle the input signal within the acquisition time of the ADC. The operational amplifier must have low noise to keep the total system noise below 20% of the input-referred noise of the ADC. For the application circuit shown in [Figure 37](#), [OPA365](#) is selected for its high bandwidth (50 MHz) and low noise (4.5 nV/√Hz).

The reference voltage for the ADS7887 and ADS7888 A/D converters are derived from the supply voltage internally. The supply to these converters must be driven with a low impedance source and must be decoupled to the ground. To drive supply pin of ADS7887 ultra low noise fast transient response low dropout voltage regulator [TPS73201](#) is selected. Alternatively one can drive supply pin with low impedance voltage reference similar to REF3030.

For a step-by-step design procedure for low power, small form factor digital acquisition (DAQ) circuit based on similar SAR ADCs refer to TI Precision Design, [Three 12-Bit Data Acquisition Reference Designs Optimized for Low Power and Ultra-Small Form Factor](#).

Typical Application (continued)

10.2.3 Application Curves

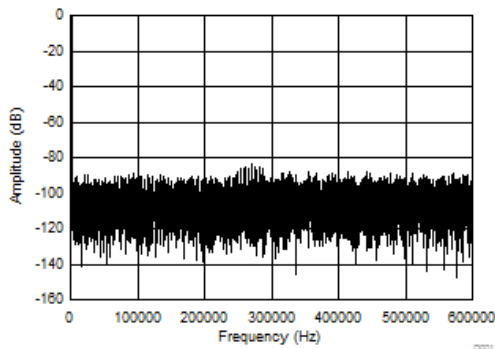

SNR: 61.9 dB THD: -86.8 dB SINAD: 61.3 dB

Figure 38. Test Results for the ADS7887 and OPA365 for a 2-kHz Input

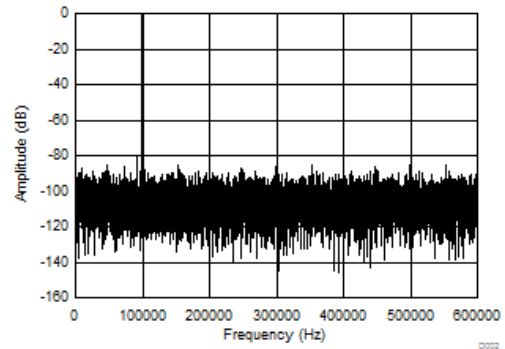

SNR: 61.8 dB THD: -85.1 dB SINAD: 61.5 dB

Figure 39. Test Results for the ADS7887 and OPA365 for a 100-kHz Input

11 Power Supply Recommendations

The reference voltage for the ADS7887 and ADS7888 A/D converters are derived from the supply voltage internally. The supply to these converters must be driven with a low impedance source and must be decoupled to the ground. Decouple the V_{DD} with 1- μF ceramic decoupling capacitors, as shown in Figure 40. Always set the V_{DD} supply to be greater than or equal to the maximum input signal to avoid saturation of codes.

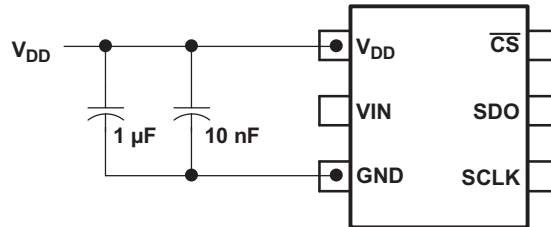

Figure 40. Supply and Reference Decoupling Capacitors

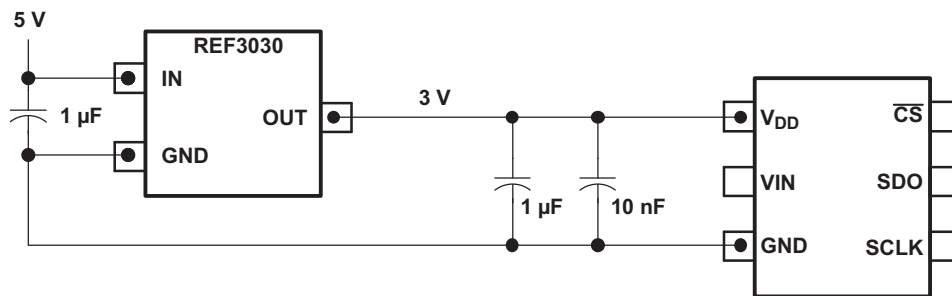

Figure 41. Using the REF3030 Reference

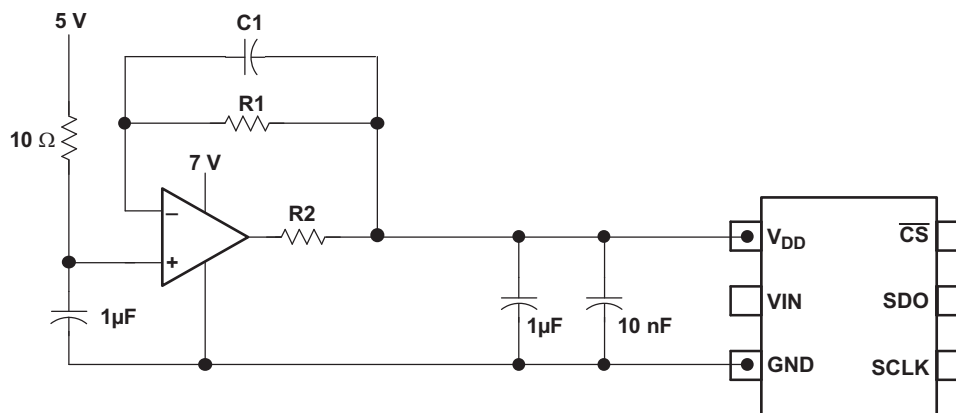

Figure 42. Buffering With the OPA735

12 Layout

12.1 Layout Guidelines

Figure 43 shows a board layout example for the ADS7887 and ADS7888. Some of the key considerations are:

1. Use a ground plane underneath the device and partition the PCB into analog and digital sections.
2. Avoid crossing digital lines with the analog signal path.
3. The power sources to the device must be clean and well-bypassed. Use 1- μ F ceramic bypass capacitors in close proximity to the supply pin (VDD).
4. Avoid placing vias between the VDD and bypass capacitors.
5. Connect ground pin to the ground plane using short, low-impedance path.
6. The fly-wheel RC filters are placed close to the device.

Among ceramic surface-mount capacitors, COG (NPO) ceramic capacitors provide the best capacitance precision. The type of dielectric used in COG (NPO) ceramic capacitors provides the most stable electrical properties over voltage, frequency, and temperature changes.

12.2 Layout Example

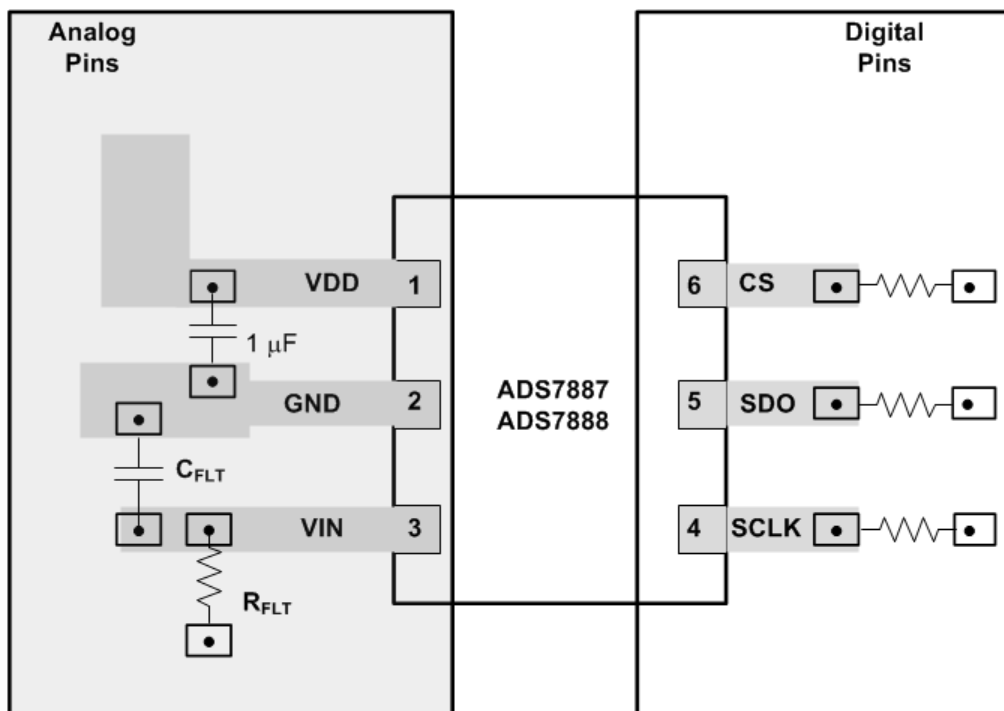

Figure 43. ADS7887 and ADS7888 Example Layout

13 Device and Documentation Support

13.1 Documentation Support

13.1.1 Related Documentation

For related documentation see the following:

- [50MHz, Low-Distortion, High CMRR, RRI/O, Single-Supply Operational Amplifier \(SBOS365\)](#)
- [Cap-Free NMOS 250-mA Low Dropout Regulator With Reverse Current Protection \(SGLS346\)](#)
- [Three 12-Bit Data Acquisition Reference Designs Optimized for Low Power and Ultra-Small Form Factor \(TIDU390\)](#)

13.2 Related Links

The table below lists quick access links. Categories include technical documents, support and community resources, tools and software, and quick access to sample or buy.

Table 1. Related Links

PARTS	PRODUCT FOLDER	SAMPLE & BUY	TECHNICAL DOCUMENTS	TOOLS & SOFTWARE	SUPPORT & COMMUNITY
ADS7887	Click here	Click here	Click here	Click here	Click here
ADS7888	Click here	Click here	Click here	Click here	Click here

13.3 Receiving Notification of Documentation Updates

To receive notification of documentation updates, navigate to the device product folder on ti.com. In the upper right corner, click on *Alert me* to register and receive a weekly digest of any product information that has changed. For change details, review the revision history included in any revised document.

13.4 Community Resources

The following links connect to TI community resources. Linked contents are provided "AS IS" by the respective contributors. They do not constitute TI specifications and do not necessarily reflect TI's views; see TI's [Terms of Use](#).

TI E2E™ Online Community *TI's Engineer-to-Engineer (E2E) Community*. Created to foster collaboration among engineers. At e2e.ti.com, you can ask questions, share knowledge, explore ideas and help solve problems with fellow engineers.

Design Support *TI's Design Support* Quickly find helpful E2E forums along with design support tools and contact information for technical support.

13.5 Trademarks

E2E is a trademark of Texas Instruments.
All other trademarks are the property of their respective owners.

13.6 Electrostatic Discharge Caution



These devices have limited built-in ESD protection. The leads should be shorted together or the device placed in conductive foam during storage or handling to prevent electrostatic damage to the MOS gates.

13.7 Glossary

[SLYZ022](#) — *TI Glossary*.

This glossary lists and explains terms, acronyms, and definitions.

14 Mechanical, Packaging, and Orderable Information

The following pages include mechanical, packaging, and orderable information. This information is the most current data available for the designated devices. This data is subject to change without notice and revision of this document. For browser-based versions of this data sheet, refer to the left-hand navigation.

PACKAGING INFORMATION

Orderable Device	Status (1)	Package Type	Package Drawing	Pins	Package Qty	Eco Plan (2)	Lead/Ball Finish (6)	MSL Peak Temp (3)	Op Temp (°C)	Device Marking (4/5)	Samples
ADS7887SDBVR	ACTIVE	SOT-23	DBV	6	3000	Green (RoHS & no Sb/Br)	CU SN	Level-2-260C-1 YEAR	-40 to 125	BAWQ	Samples
ADS7887SDBVT	ACTIVE	SOT-23	DBV	6	250	Green (RoHS & no Sb/Br)	CU SN	Level-2-260C-1 YEAR	-40 to 125	BAWQ	Samples
ADS7887SDCKR	ACTIVE	SC70	DCK	6	3000	Pb-Free (RoHS Exempt)	CU SN	Level-2-260C-1 YEAR	-40 to 125	BNH	Samples
ADS7887SDCKT	ACTIVE	SC70	DCK	6	250	Pb-Free (RoHS Exempt)	CU SN	Level-2-260C-1 YEAR	-40 to 125	BNH	Samples
ADS7888SDBVR	ACTIVE	SOT-23	DBV	6	3000	Green (RoHS & no Sb/Br)	CU SN	Level-2-260C-1 YEAR	-40 to 125	BAZQ	Samples
ADS7888SDBVT	ACTIVE	SOT-23	DBV	6	250	Green (RoHS & no Sb/Br)	CU SN	Level-2-260C-1 YEAR	-40 to 125	BAZQ	Samples
ADS7888SDCKR	ACTIVE	SC70	DCK	6	3000	Pb-Free (RoHS Exempt)	CU SN	Level-2-260C-1 YEAR	-40 to 125	BNH	Samples
ADS7888SDCKT	ACTIVE	SC70	DCK	6	250	Pb-Free (RoHS Exempt)	CU SN	Level-2-260C-1 YEAR	-40 to 125	BNH	Samples

(1) The marketing status values are defined as follows:

ACTIVE: Product device recommended for new designs.

LIFEBUY: TI has announced that the device will be discontinued, and a lifetime-buy period is in effect.

NRND: Not recommended for new designs. Device is in production to support existing customers, but TI does not recommend using this part in a new design.

PREVIEW: Device has been announced but is not in production. Samples may or may not be available.

OBSELETE: TI has discontinued the production of the device.

(2) **RoHS:** TI defines "RoHS" to mean semiconductor products that are compliant with the current EU RoHS requirements for all 10 RoHS substances, including the requirement that RoHS substance do not exceed 0.1% by weight in homogeneous materials. Where designed to be soldered at high temperatures, "RoHS" products are suitable for use in specified lead-free processes. TI may reference these types of products as "Pb-Free".

RoHS Exempt: TI defines "RoHS Exempt" to mean products that contain lead but are compliant with EU RoHS pursuant to a specific EU RoHS exemption.

Green: TI defines "Green" to mean the content of Chlorine (Cl) and Bromine (Br) based flame retardants meet JS709B low halogen requirements of <=100ppm threshold. Antimony trioxide based flame retardants must also meet the <=1000ppm threshold requirement.

(3) MSL, Peak Temp. - The Moisture Sensitivity Level rating according to the JEDEC industry standard classifications, and peak solder temperature.

(4) There may be additional marking, which relates to the logo, the lot trace code information, or the environmental category on the device.

(5) Multiple Device Markings will be inside parentheses. Only one Device Marking contained in parentheses and separated by a "-" will appear on a device. If a line is indented then it is a continuation of the previous line and the two combined represent the entire Device Marking for that device.

(6) Lead/Ball Finish - Orderable Devices may have multiple material finish options. Finish options are separated by a vertical ruled line. Lead/Ball Finish values may wrap to two lines if the finish value exceeds the maximum column width.

Important Information and Disclaimer:The information provided on this page represents TI's knowledge and belief as of the date that it is provided. TI bases its knowledge and belief on information provided by third parties, and makes no representation or warranty as to the accuracy of such information. Efforts are underway to better integrate information from third parties. TI has taken and continues to take reasonable steps to provide representative and accurate information but may not have conducted destructive testing or chemical analysis on incoming materials and chemicals. TI and TI suppliers consider certain information to be proprietary, and thus CAS numbers and other limited information may not be available for release.

In no event shall TI's liability arising out of such information exceed the total purchase price of the TI part(s) at issue in this document sold by TI to Customer on an annual basis.

OTHER QUALIFIED VERSIONS OF ADS7887 :

- Military: [ADS7887M](#)

NOTE: Qualified Version Definitions:

- Military - QML certified for Military and Defense Applications

TAPE AND REEL INFORMATION

QUADRANT ASSIGNMENTS FOR PIN 1 ORIENTATION IN TAPE

*All dimensions are nominal

Device	Package Type	Package Drawing	Pins	SPQ	Reel Diameter (mm)	Reel Width W1 (mm)	A0 (mm)	B0 (mm)	K0 (mm)	P1 (mm)	W (mm)	Pin1 Quadrant
ADS7887SDBVR	SOT-23	DBV	6	3000	180.0	8.4	3.2	3.2	1.4	4.0	8.0	Q3
ADS7887SDBVT	SOT-23	DBV	6	250	177.8	9.7	3.2	3.1	1.39	4.0	8.0	Q3
ADS7887SDCKR	SC70	DCK	6	3000	177.8	9.7	2.3	2.52	1.2	4.0	8.0	Q3
ADS7887SDCKT	SC70	DCK	6	250	177.8	9.7	2.3	2.52	1.2	4.0	8.0	Q3
ADS7888SDBVR	SOT-23	DBV	6	3000	180.0	8.4	3.2	3.2	1.4	4.0	8.0	Q3
ADS7888SDBVT	SOT-23	DBV	6	250	180.0	8.4	3.2	3.2	1.4	4.0	8.0	Q3
ADS7888SDCKR	SC70	DCK	6	3000	177.8	9.7	2.3	2.52	1.2	4.0	8.0	Q3
ADS7888SDCKT	SC70	DCK	6	250	177.8	9.7	2.3	2.52	1.2	4.0	8.0	Q3

TAPE AND REEL BOX DIMENSIONS

*All dimensions are nominal

Device	Package Type	Package Drawing	Pins	SPQ	Length (mm)	Width (mm)	Height (mm)
ADS7887SDBVR	SOT-23	DBV	6	3000	195.0	200.0	45.0
ADS7887SDBVT	SOT-23	DBV	6	250	184.0	184.0	50.0
ADS7887SDCKR	SC70	DCK	6	3000	184.0	184.0	50.0
ADS7887SDCKT	SC70	DCK	6	250	184.0	184.0	50.0
ADS7888SDBVR	SOT-23	DBV	6	3000	195.0	200.0	45.0
ADS7888SDBVT	SOT-23	DBV	6	250	195.0	200.0	45.0
ADS7888SDCKR	SC70	DCK	6	3000	184.0	184.0	50.0
ADS7888SDCKT	SC70	DCK	6	250	184.0	184.0	50.0

DBV0006A



PACKAGE OUTLINE

SOT-23 - 1.45 mm max height

SMALL OUTLINE TRANSISTOR



NOTES:

1. All linear dimensions are in millimeters. Any dimensions in parenthesis are for reference only. Dimensioning and tolerancing per ASME Y14.5M.
2. This drawing is subject to change without notice.
3. Body dimensions do not include mold flash or protrusion. Mold flash and protrusion shall not exceed 0.15 per side.
4. Leads 1,2,3 may be wider than leads 4,5,6 for package orientation.
5. Reference JEDEC MO-178.

EXAMPLE BOARD LAYOUT

DBV0006A

SOT-23 - 1.45 mm max height

SMALL OUTLINE TRANSISTOR



LAND PATTERN EXAMPLE
EXPOSED METAL SHOWN
SCALE:15X

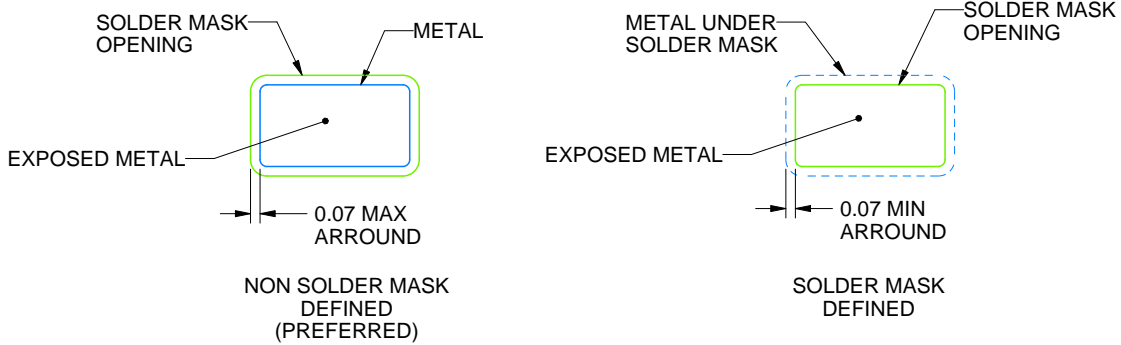

SOLDER MASK DETAILS

4214840/B 03/2018

NOTES: (continued)

- 6. Publication IPC-7351 may have alternate designs.
- 7. Solder mask tolerances between and around signal pads can vary based on board fabrication site.

EXAMPLE STENCIL DESIGN

DBV0006A

SOT-23 - 1.45 mm max height

SMALL OUTLINE TRANSISTOR



SOLDER PASTE EXAMPLE
BASED ON 0.125 mm THICK STENCIL
SCALE:15X

4214840/B 03/2018

NOTES: (continued)

8. Laser cutting apertures with trapezoidal walls and rounded corners may offer better paste release. IPC-7525 may have alternate design recommendations.
9. Board assembly site may have different recommendations for stencil design.

DCK (R-PDSO-G6)

PLASTIC SMALL-OUTLINE PACKAGE

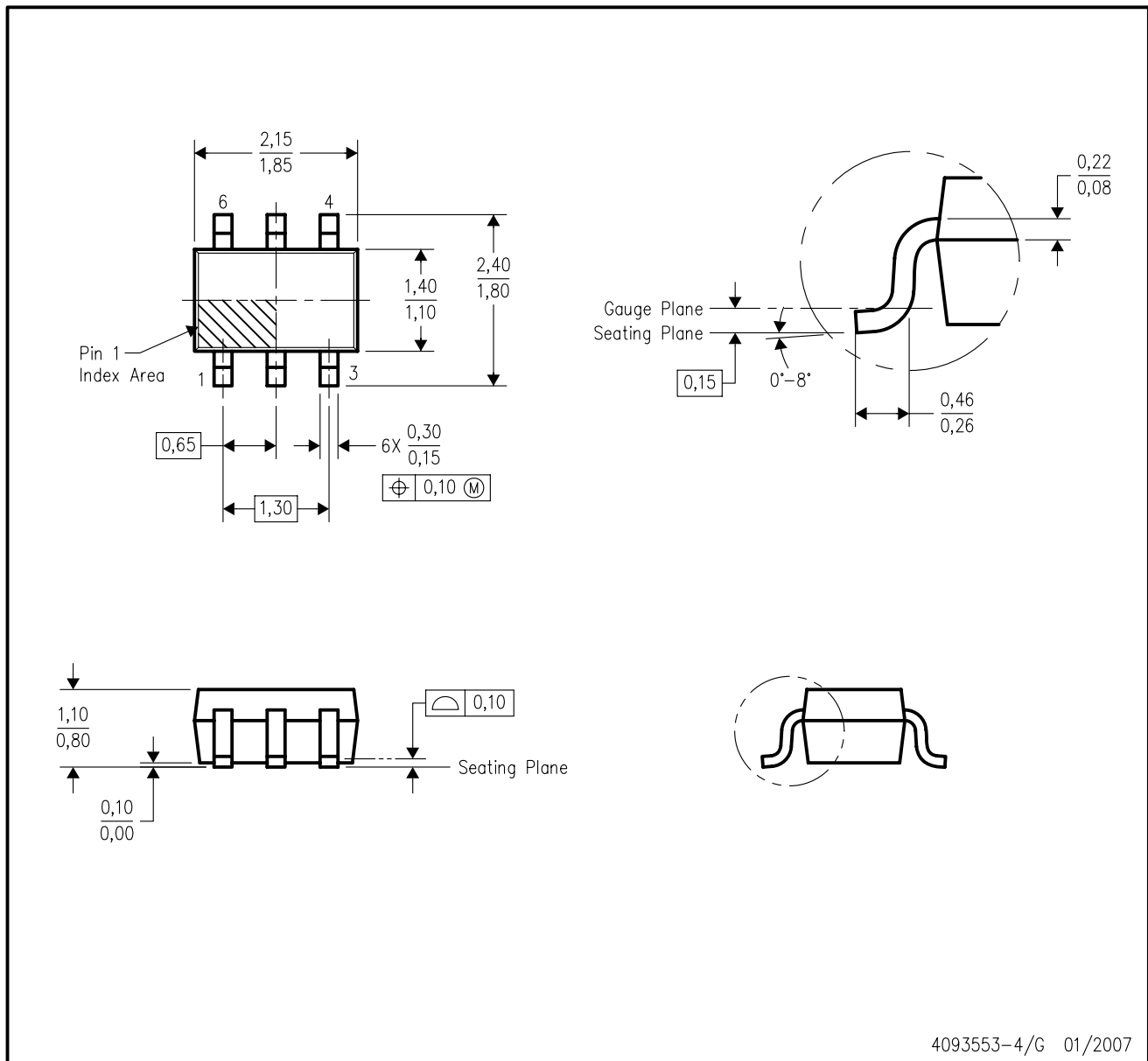

- NOTES:
- A. All linear dimensions are in millimeters.
 - B. This drawing is subject to change without notice.
 - C. Body dimensions do not include mold flash or protrusion. Mold flash and protrusion shall not exceed 0.15 per side.
 - D. Falls within JEDEC MO-203 variation AB.

DCK (R-PDSO-G6)

PLASTIC SMALL OUTLINE

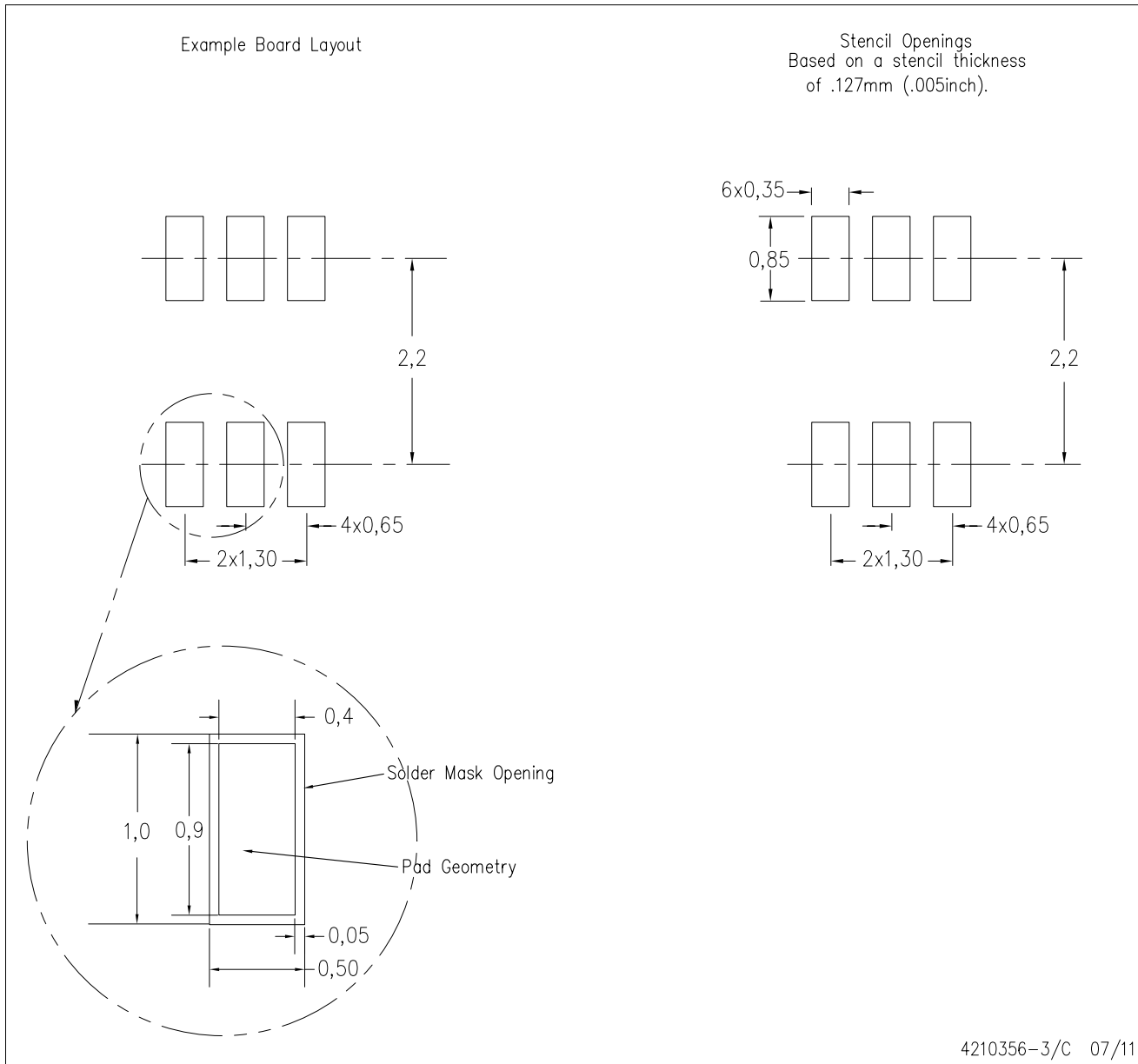

- NOTES:
- All linear dimensions are in millimeters.
 - This drawing is subject to change without notice.
 - Customers should place a note on the circuit board fabrication drawing not to alter the center solder mask defined pad.
 - Publication IPC-7351 is recommended for alternate designs.
 - Laser cutting apertures with trapezoidal walls and also rounding corners will offer better paste release. Customers should contact their board assembly site for stencil design recommendations. Example stencil design based on a 50% volumetric metal load solder paste. Refer to IPC-7525 for other stencil recommendations.

IMPORTANT NOTICE AND DISCLAIMER

TI PROVIDES TECHNICAL AND RELIABILITY DATA (INCLUDING DATASHEETS), DESIGN RESOURCES (INCLUDING REFERENCE DESIGNS), APPLICATION OR OTHER DESIGN ADVICE, WEB TOOLS, SAFETY INFORMATION, AND OTHER RESOURCES "AS IS" AND WITH ALL FAULTS, AND DISCLAIMS ALL WARRANTIES, EXPRESS AND IMPLIED, INCLUDING WITHOUT LIMITATION ANY IMPLIED WARRANTIES OF MERCHANTABILITY, FITNESS FOR A PARTICULAR PURPOSE OR NON-INFRINGEMENT OF THIRD PARTY INTELLECTUAL PROPERTY RIGHTS.

These resources are intended for skilled developers designing with TI products. You are solely responsible for (1) selecting the appropriate TI products for your application, (2) designing, validating and testing your application, and (3) ensuring your application meets applicable standards, and any other safety, security, or other requirements. These resources are subject to change without notice. TI grants you permission to use these resources only for development of an application that uses the TI products described in the resource. Other reproduction and display of these resources is prohibited. No license is granted to any other TI intellectual property right or to any third party intellectual property right. TI disclaims responsibility for, and you will fully indemnify TI and its representatives against, any claims, damages, costs, losses, and liabilities arising out of your use of these resources.

TI's products are provided subject to TI's Terms of Sale (www.ti.com/legal/termsofsale.html) or other applicable terms available either on ti.com or provided in conjunction with such TI products. TI's provision of these resources does not expand or otherwise alter TI's applicable warranties or warranty disclaimers for TI products.

Mailing Address: Texas Instruments, Post Office Box 655303, Dallas, Texas 75265
Copyright © 2019, Texas Instruments Incorporated

Looking for pricing, stock, or lifecycle information?

Click below to explore more details on WIN SOURCE:

 [View ADS7888SDBVT](#) on WIN SOURCE

 [Texas Instruments](#) Information

Optimize Your Supply Chain with WIN SOURCE Solutions

-  Global Sourcing Solution
-  Obsolete Management
-  Cost Control Management
-  Shortage Management
-  Alternative Solution
-  Excess Inventory Management