



**THE DATASHEET OF  
IXDD504PI**



## IXDD504/ IXDE504

### 4 Ampere Dual Low-Side Ultrafast MOSFET Drivers with Enable for fast, controlled shutdown

#### Features

- Built using the advantages and compatibility of CMOS and IXYS HDMOS™ processes
- Latch-Up Protected up to 4 Amps
- High 4A Peak Output Current
- Wide Operating Range: 4.5V to 30V
- -55°C to +125°C Extended Operating Temperature
- Ability to Disable Output under Faults
- High Capacitive Load  
Drive Capability: 1800pF in <15ns
- Matched Rise And Fall Times
- Low Propagation Delay Time
- Low Output Impedance
- Low Supply Current
- Two Drivers in a Single Package

#### Applications

- Limiting di/dt under Short Circuit
- Driving MOSFETs and IGBTs
- Motor Controls
- Line Drivers
- Pulse Generators
- Local Power ON/OFF Switch
- Switch Mode Power Supplies (SMPS)
- DC to DC Converters
- Pulse Transformer Driver
- Class D Switching Amplifiers
- Power Charge Pumps

#### General Description

The IXDD504 and IXDE504 each consist of two 4-Amp CMOS high speed MOSFET gate drivers for driving the latest IXYS MOSFETs & IGBTs. Each of the dual outputs can source and sink 4 Amps of peak current while producing voltage rise and fall times of less than 15ns. The input of each driver is TTL or CMOS compatible and is virtually immune to latch up. Patented\* design innovations eliminate cross conduction and current "shoot-through". Improved speed and drive capabilities are further enhanced by fast, matched rise and fall times.

Additionally, each IXDD504 or IXDE504 driver incorporates a unique ability to disable the output under fault conditions. When a logical low is forced into the Enable input of a driver, both of it's final output stage MOSFETs (NMOS and PMOS) are turned off. As a result, the respective output of the IXDD504 enters a tristate mode and, with additional circuitry, achieves a soft turn-off of the MOSFET/IGBT when a short circuit is detected. This helps prevent damage that could occur to the MOSFET/IGBT if it were to be switched off abruptly due to a dv/dt over-voltage transient.

The IXDD504 and IXDE504 are each available in the 8-Pin P-DIP (PI) package, the 8-Pin SOIC (SIA) package, and the 8-Lead DFN (D2) package, (which occupies less than 65% of the board area of the 8-Pin SOIC).

\*United States Patent 6,917,227

#### Ordering Information

Part Number	Description	Package Type	Packing Style	Pack Qty	Configuration
IXDD504PI	4A Low Side Gate Driver I.C.	8-Pin PDIP	Tube	50	Dual Non-Inverting Drivers with Enable
IXDD504SIA	4A Low Side Gate Driver I.C.	8-Pin SOIC	Tube	94	
IXDD504SIAT/R	4A Low Side Gate Driver I.C.	8-Pin SOIC	13" Tape and Reel	2500	
IXDD504D2	4A Low Side Gate Driver I.C.	8-Lead DFN	2" x 2" Waffle Pack	56	
IXDD504D2T/R	4A Low Side Gate Driver I.C.	8-Lead DFN	13" Tape and Reel	2500	
IXDE504PI	4A Low Side Gate Driver I.C.	8-Pin PDIP	Tube	50	Dual Inverting Drivers Inverting with Enable
IXDE504SIA	4A Low Side Gate Driver I.C.	8-Pin SOIC	Tube	94	
IXDE504SIAT/R	4A Low Side Gate Driver I.C.	8-Pin SOIC	13" Tape and Reel	2500	
IXDE504D2	4A Low Side Gate Driver I.C.	8-Lead DFN	2" x 2" Waffle Pack	56	
IXDE504D2T/R	4A Low Side Gate Driver I.C.	8-Lead DFN	13" Tape and Reel	2500	

**NOTE:** All parts are lead-free and RoHS Compliant

**Figure 1 - IXDD504 Dual Non-Inverting + Enable 4A Gate Driver Functional Block Diagram**

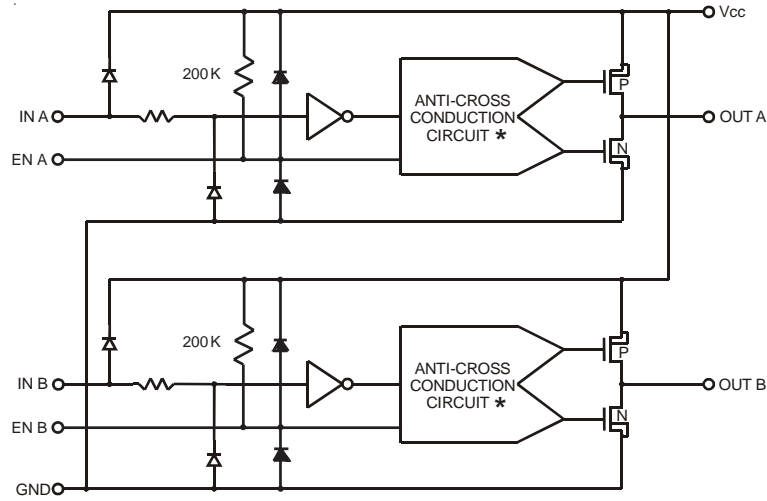

**Figure 2 - IXDE504 Dual Inverting + Enable 4A Gate Driver Functional Block Diagram**

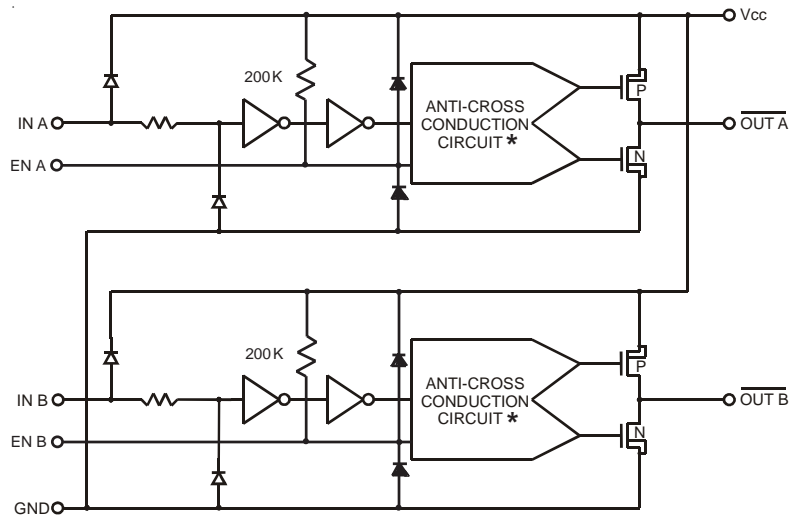

\* United States Patent 6,917,227

**Absolute Maximum Ratings <sup>(1)</sup>**

Parameter	Value
Supply Voltage	35 V
All Other Pins (unless specified otherwise)	-0.3 V to $V_{CC} + 0.3V$
Junction Temperature	150 °C
Storage Temperature	-65 °C to 150 °C
Lead Temperature (10 Sec)	300 °C

**Operating Ratings <sup>(2)</sup>**

Parameter	Value
Operating Supply Voltage	4.5V to 30V
Operating Temperature Range	-55 °C to 125 °C
Package Thermal Resistance*	
8-Pin PDIP (PI)	$\theta_{J-A}$ (typ) 125 °C/W
8-Pin SOIC (SIA)	$\theta_{J-A}$ (typ) 200 °C/W
8-Lead DFN (D2)	$\theta_{J-A}$ (typ) 125-200 °C/W
8-Lead DFN (D2)	$\theta_{J-C}$ (max) 2.1 °C/W
8-Lead DFN (D2)	$\theta_{J-S}$ (typ) 6.4 °C/W

**Electrical Characteristics @  $T_A = 25\text{ °C}$  <sup>(3)</sup>**

Unless otherwise noted,  $4.5V \leq V_{CC} \leq 30V$ .

All voltage measurements with respect to GND. IXD\_504 configured as described in *Test Conditions*. All specifications are for one channel.

Symbol	Parameter	Test Conditions	Min	Typ <sup>(4)</sup>	Max	Units
$V_{IH}, V_{ENH}$	High input & EN voltage	$4.5V \leq V_{IN} \leq 18V$	3			V
$V_{IL}, V_{ENL}$	Low input & EN voltage	$4.5V \leq V_{IN} \leq 18V$			0.8	V
$V_{IN}$	Input voltage range		-5		$V_{CC} + 0.3$	V
$V_{EN}$	Enable voltage range		-0.3		$V_{CC} + 0.3$	V
$I_{IN}$	Input current	$0V \leq V_{IN} \leq V_{CC}$	-10		10	$\mu A$
$V_{OH}$	High output voltage		$V_{CC} - 0.025$			V
$V_{OL}$	Low output voltage				0.025	V
$R_{OH}$	High state output resistance	$V_{CC} = 18V$ $I_{OUT} = 10mA$		1.5	2.5	$\Omega$
$R_{OL}$	Low state output resistance	$V_{CC} = 18V$ $I_{OUT} = 10mA$		1.2	2.0	$\Omega$
$I_{PEAK}$	Peak output current	$V_{CC} = 15V$		4		A
$I_{DC}$	Continuous output current	Limited by package dissipation			1	A
$t_R$	Rise time	$C_{LOAD} = 1000pF$ $V_{CC} = 18V$		9	16	ns
$t_F$	Fall time	$C_{LOAD} = 1000pF$ $V_{CC} = 18V$		8	14	ns
$t_{ONDLY}$	On-time propagation delay	$C_{LOAD} = 1000pF$ $V_{CC} = 18V$		19	40	ns
$t_{OFFDLY}$	Off-time propagation delay	$C_{LOAD} = 1000pF$ $V_{CC} = 18V$		18	35	ns
$t_{ENOH}$	Enable to output high delay time			15	30	ns
$t_{DOLD}$	Disable to high impedance state delay time			63	100	ns
$V_{CC}$	Power supply voltage		4.5	18	30	V
$R_{EN}$	Enable Pull-up Resistor			200		k $\Omega$
$I_{CC}$	Power supply current	$V_{CC} = 18V, V_{IN} = 0V$ $V_{IN} = 3.5V$ $V_{IN} = V_{CC}$		1	20 3 20	$\mu A$ mA mA

**Electrical Characteristics @ temperatures over -55 °C to 125 °C <sup>(3)</sup>**

Unless otherwise noted,  $4.5V \leq V_{CC} \leq 30V$ ,  $T_j < 150^\circ C$

All voltage measurements with respect to GND. IXD\_504 configured as described in *Test Conditions*. All specifications are for one channel.

Symbol	Parameter	Test Conditions	Min	Typ	Max	Units
$V_{IH}$	High input voltage	$4.5V \leq V_{CC} \leq 18V$	3			V
$V_{IL}$	Low input voltage	$4.5V \leq V_{CC} \leq 18V$			0.8	V
$V_{IN}$	Input voltage range		-5		$V_{CC} + 0.3$	V
$I_{IN}$	Input current	$0V \leq V_{IN} \leq V_{CC}$	-10		10	$\mu A$
$V_{OH}$	High output voltage		$V_{CC} - 0.025$			V
$V_{OL}$	Low output voltage				0.025	V
$R_{OH}$	High state output resistance	$V_{CC} = 18V, I_{OUT} = 10mA$			3	$\Omega$
$R_{OL}$	Low state output resistance	$V_{CC} = 18V, I_{OUT} = 10mA$			2.5	$\Omega$
$I_{DC}$	Continuous output current				1	A
$t_R$	Rise time	$C_{LOAD} = 1000pF, V_{CC} = 18V$			10	ns
$t_F$	Fall time	$C_{LOAD} = 1000pF, V_{CC} = 18V$			9	ns
$t_{ONDLy}$	On-time propagation delay	$C_{LOAD} = 1000pF, V_{CC} = 18V$			23	ns
$t_{OFFDLy}$	Off-time propagation delay	$C_{LOAD} = 1000pF, V_{CC} = 18V$			32	ns
$t_{ENOH}$	Enable to output high delay time				60	ns
$t_{DOLD}$	Disable to high impedance state delay time				120	ns
$V_{CC}$	Power supply voltage		4.5	18	30	V
$I_{HIOL}$	High impedance state output leakage	$V_{CC} = 18V, Temp. = 125^\circ C$			200	$\mu A$
$I_{CC}$	Power supply current	$V_{CC} = 18V, V_{IN} = 0V$ $V_{IN} = 3.5V$ $V_{IN} = V_{CC}$			150 3 150	$\mu A$ mA mA

**Notes:**

1. Operating the device beyond the parameters listed as "Absolute Maximum Ratings" may cause permanent damage to the device. Exposure to absolute maximum rated conditions for extended periods may affect device reliability.
2. The device is not intended to be operated outside of the Operating Ratings.
3. Electrical Characteristics provided are associated with the stated Test Conditions.
4. Typical values are presented in order to communicate how the device is expected to perform, but not necessarily to highlight any specific performance limits within which the device is guaranteed to function.

\* The following notes are meant to define the conditions for the  $\theta_{J-A}$ ,  $\theta_{J-C}$  and  $\theta_{J-S}$  values:

- 1) The  $\theta_{J-A}$  (typ) is defined as junction to ambient. The  $\theta_{J-A}$  of the standard single die 8-Lead PDIP and 8-Lead SOIC are dominated by the resistance of the package, and the IXD\_5XX are typical. The values for these packages are natural convection values with vertical boards and the values would be lower with forced convection. For the 8-Lead DFN package, the  $\theta_{J-A}$  value supposes the DFN package is soldered on a PCB. The  $\theta_{J-A}$  (typ) is  $200^\circ C/W$  with no special provisions on the PCB, but because the center pad provides a low thermal resistance to the die, it is easy to reduce the  $\theta_{J-A}$  by adding connected copper pads or traces on the PCB. These can reduce the  $\theta_{J-A}$  (typ) to  $125^\circ C/W$  easily, and potentially even lower. The  $\theta_{J-A}$  for DFN on PCB without heatsink or thermal management will vary significantly with size, construction, layout, materials, etc. This typical range tells the user what he is likely to get if he does no thermal management.
- 2)  $\theta_{J-C}$  (max) is defined as junction to case, where case is the large pad on the back of the DFN package. The  $\theta_{J-C}$  values are generally not published for the PDIP and SOIC packages. The  $\theta_{J-C}$  for the DFN packages are important to show the low thermal resistance from junction to the die attach pad on the back of the DFN, -- and a guardband has been added to be safe.
- 3) The  $\theta_{J-S}$  (typ) is defined as junction to heatsink, where the DFN package is soldered to a thermal substrate that is mounted on a heatsink. The value must be typical because there are a variety of thermal substrates. This value was calculated based on easily available IMS in the U.S. or Europe, and not a premium Japanese IMS. A 4 mil dielectric with a thermal conductivity of  $2.2W/mC$  was assumed. The result was given as typical, and indicates what a user would expect on a typical IMS substrate, and shows the potential low thermal resistance for the DFN package.

**Pin Description**

SYMBOL	FUNCTION	DESCRIPTION
EN A	A Channel Enable	Channel A enable pin. When driven low, this pin disables the A channel and forces a high impedance state to the A channel output.
IN A	A Channel Input	A channel input signal-TTL or CMOS compatible.
GND	Ground	The system ground pin. Internally connected to all circuitry, this pin provides ground reference for the entire chip. This pin should be connected to a low noise analog ground plane for optimum performance.
IN B	B Channel Input	B channel input signal-TTL or CMOS compatible.
OUT B	B Channel Output	B channel driver output. For application purposes, this pin is connected via a resistor to the gate of a MOSFET/IGBT.
VCC	Supply Voltage	Positive power-supply voltage input. This pin provides power to the entire chip. The range for this voltage is from 4.5V to 30V.
OUT A	A Channel Output	A channel driver output. For application purposes, this pin is connected via a resistor to the gate of a MOSFET/IGBT.
EN B	B Channel Enable	Channel B enable pin. When driven low, this pin disables the B channel and forces a high impedance state to the B channel output.

**CAUTION:** Follow proper ESD procedures when handling and assembling this component.

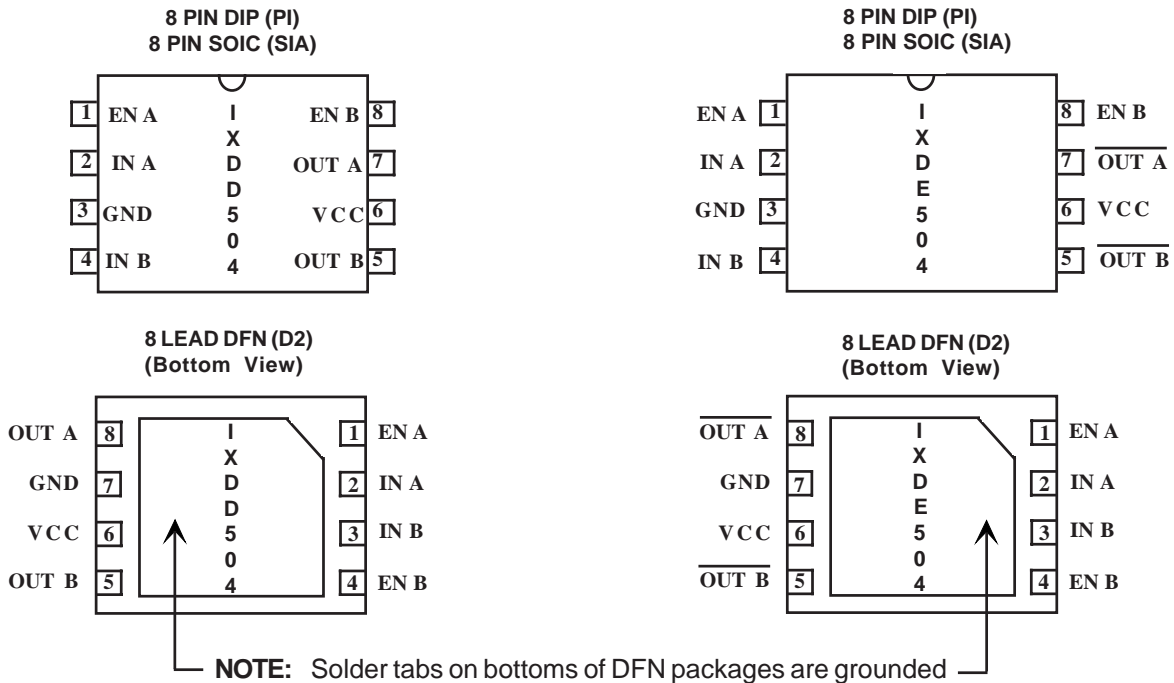
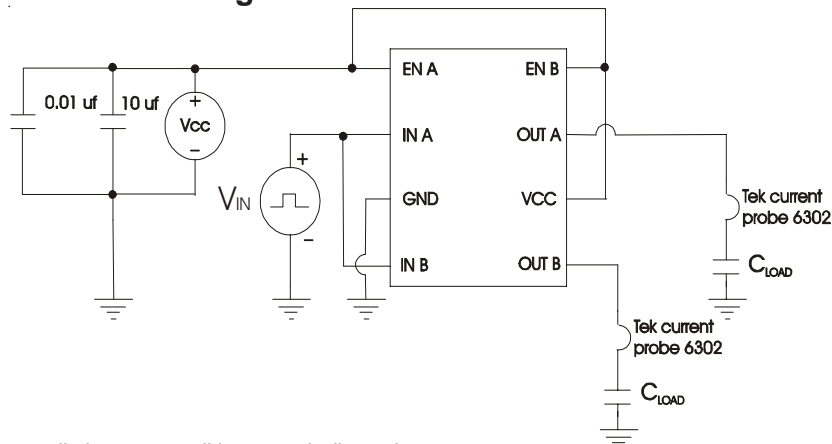
**Pin Configurations**

**Figure 3 - Characteristics Test Diagram**

## Typical Performance Characteristics

Fig. 4

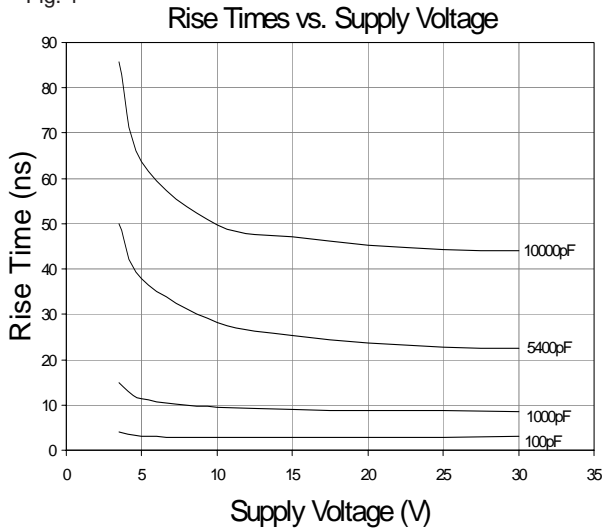

Fig. 5

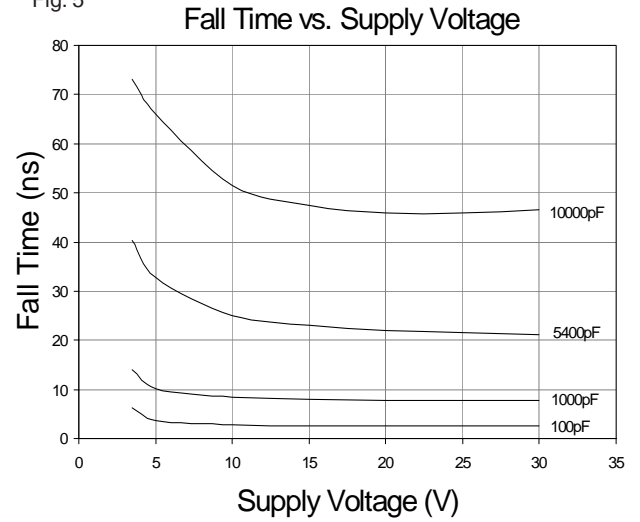

Fig. 6

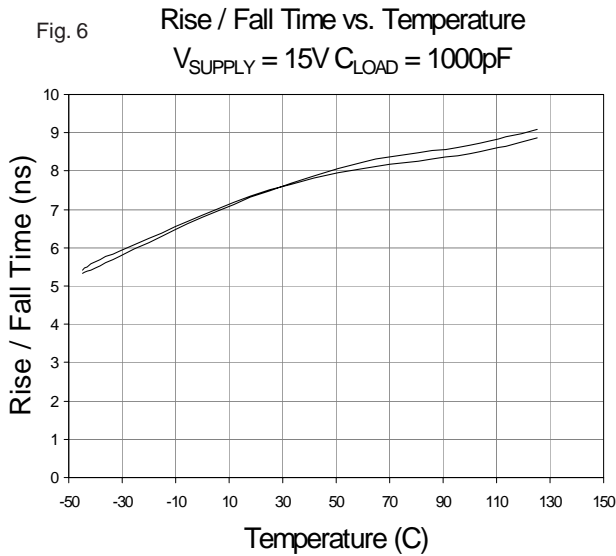

Fig. 7

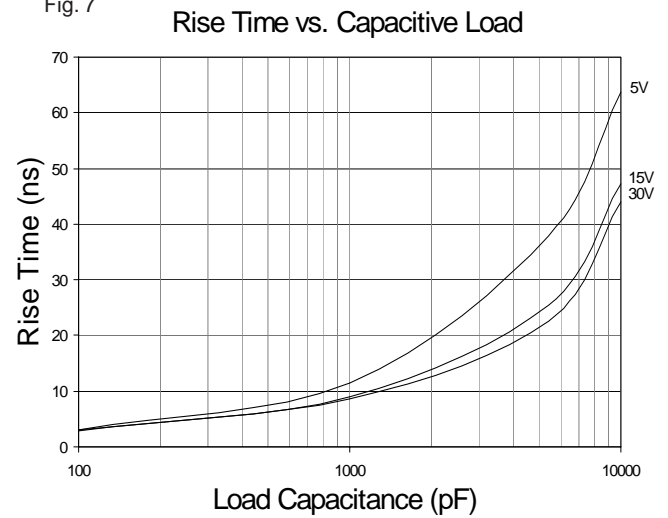

Fig. 8

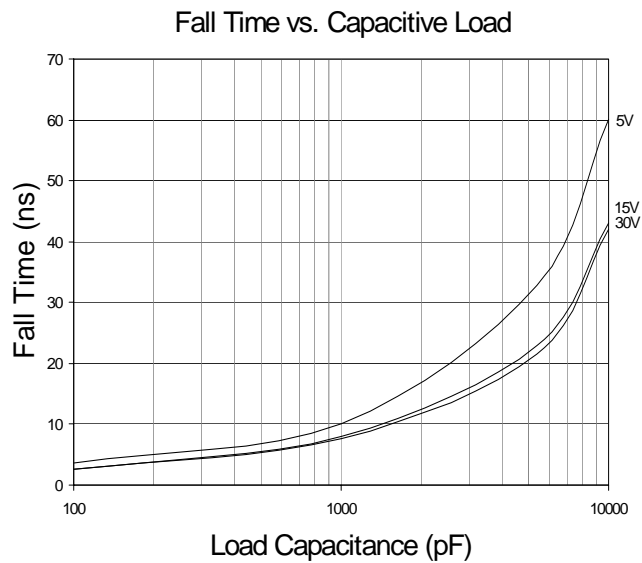

Fig. 9

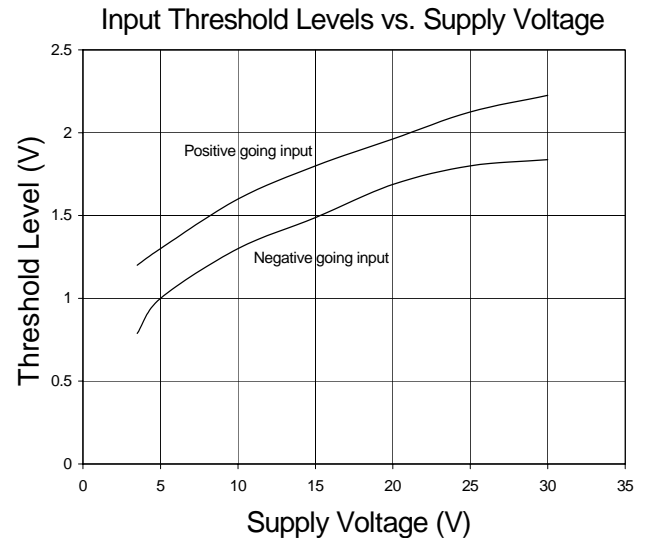

Fig. 10 Input Threshold Levels vs. Temperature

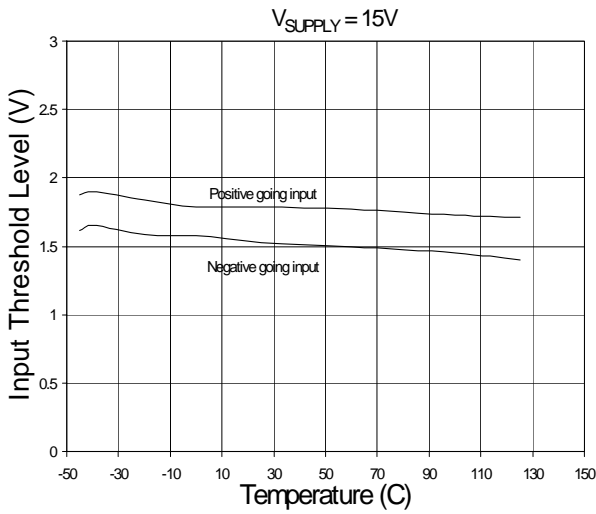

Fig. 11 Propagation Delay vs. Supply Voltage  
Rising Input,  $C_{LOAD} = 1000pF$

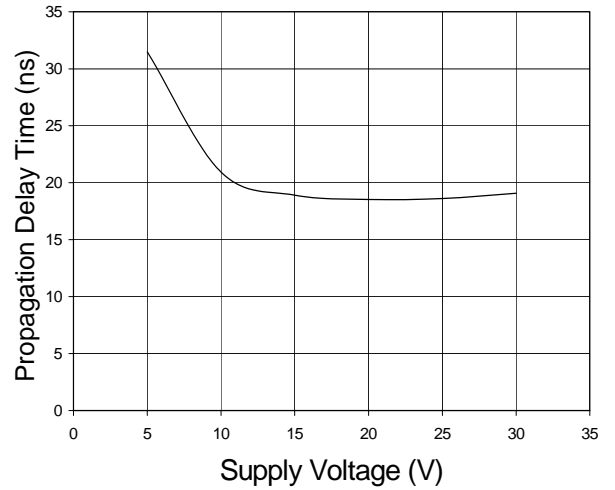

Fig. 12 Propagation Delay vs. Supply Voltage  
Falling Input,  $C_{LOAD} = 1000pF$

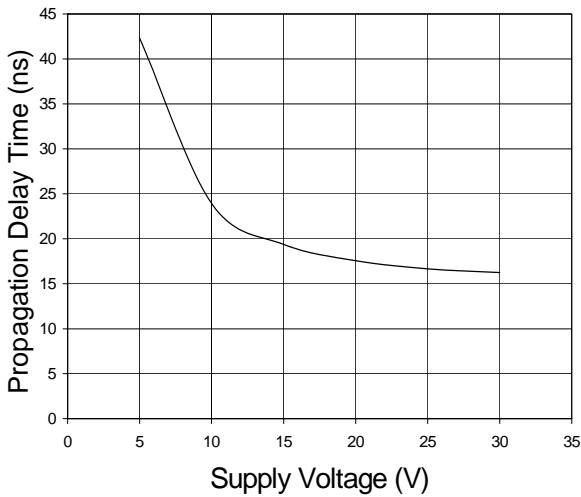

Fig. 13 Propagation Delay vs. Temperature  
 $V_{SUPPLY} = 15V$   $C_{LOAD} = 1000pF$

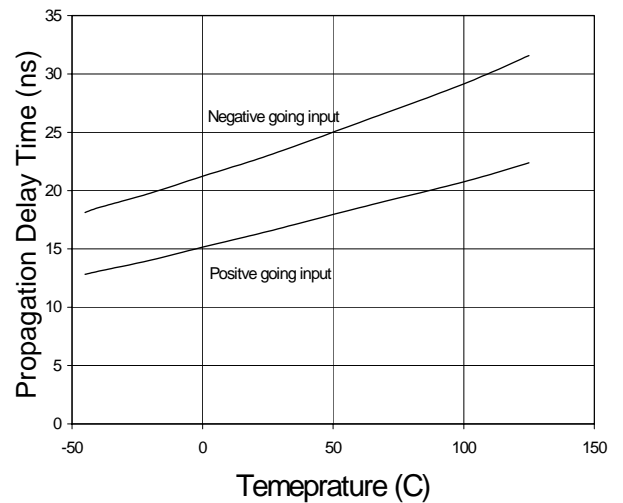

Fig. 14 Quiescent Current vs. Supply Voltage

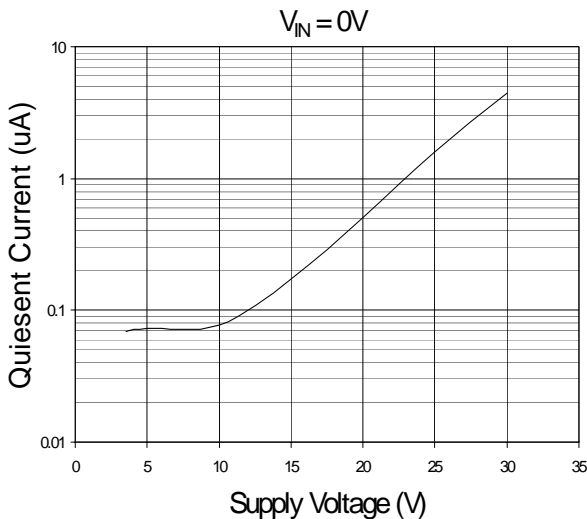
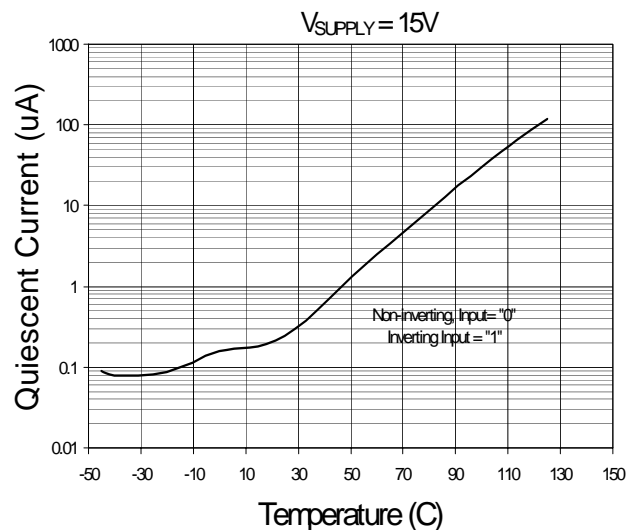
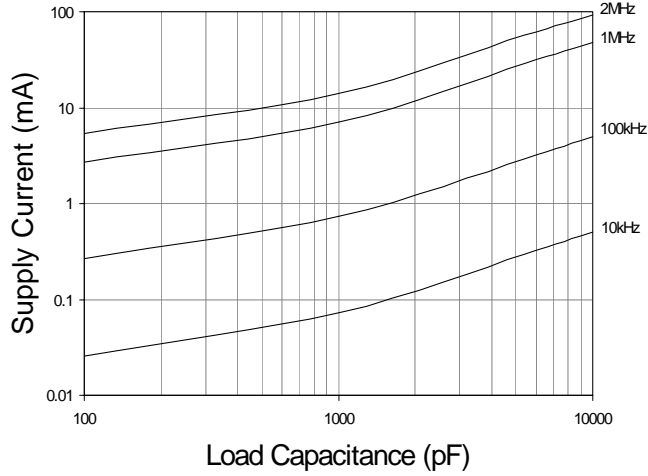
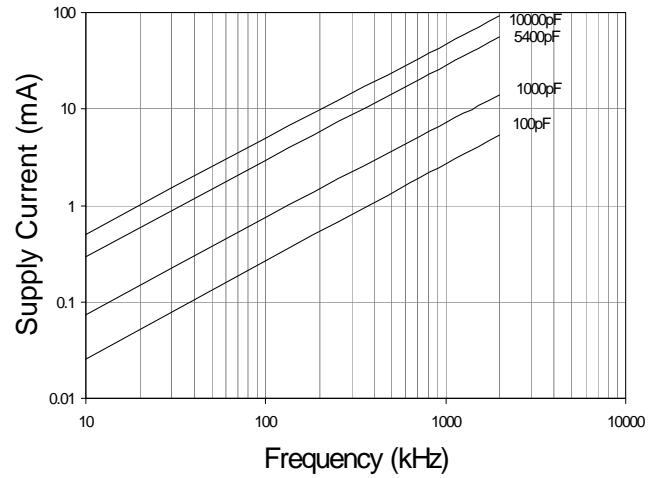
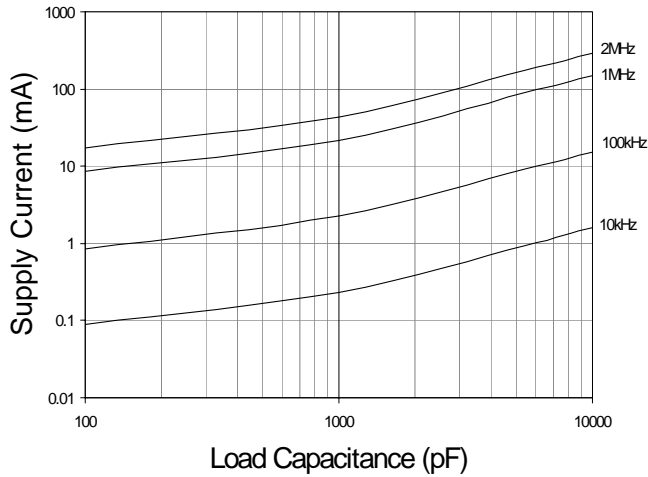
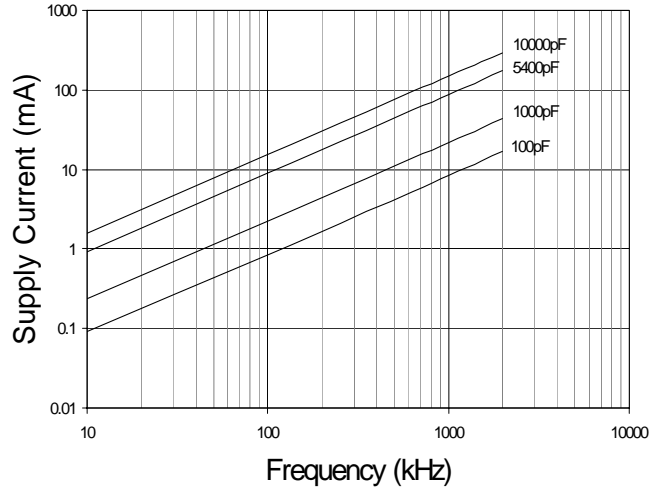
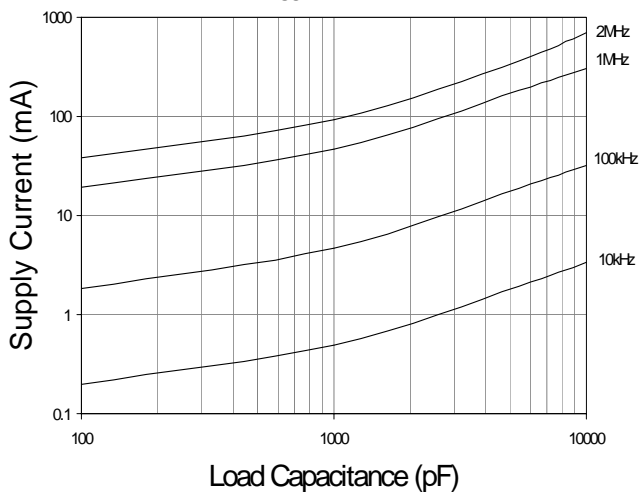
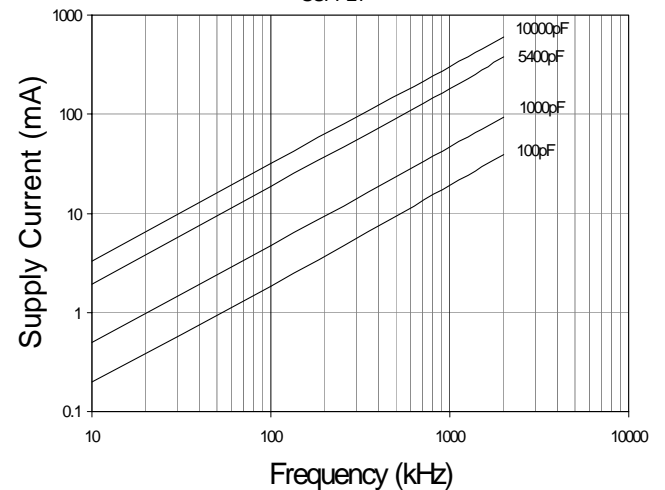

Fig. 15 Quiescent Current vs. Temperature



**Fig. 16 Supply Current vs. Capacitive Load**
 $V_{\text{SUPPLY}} = 5\text{V}$ 

**Fig. 17 Supply Current vs. Frequency**
 $V_{\text{SUPPLY}} = 5\text{V}$ 

**Fig. 18 Supply Current vs. Capacitive Load**
 $V_{\text{SUPPLY}} = 15\text{V}$ 

**Fig. 19 Supply Current vs. Frequency**
 $V_{\text{SUPPLY}} = 15\text{V}$ 

**Fig. 20 Supply Current vs. Capacitive Load**
 $V_{\text{SUPPLY}} = 30\text{V}$ 

**Fig. 21 Supply Current vs. Frequency**
 $V_{\text{SUPPLY}} = 30\text{V}$ 

**Fig. 22 Output Source Current vs. Supply Voltage**

**Fig. 23 Output Sink Current vs. Supply Voltage**

**Fig. 24 Output Source Current vs. Temperature**  
 $V_{\text{SUPPLY}} = 15\text{V}$ 

**Fig. 25 Output Sink Current vs. Temperature**  
 $V_{\text{SUPPLY}} = 15\text{V}$ 

**Fig. 26 High State Output Resistance vs. Supply Voltage**

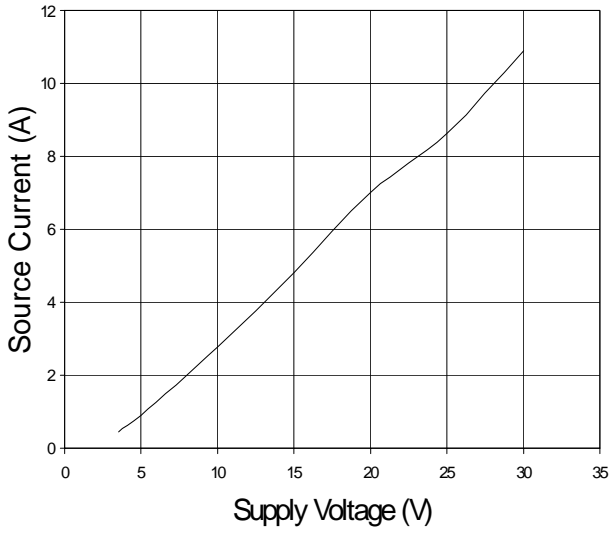
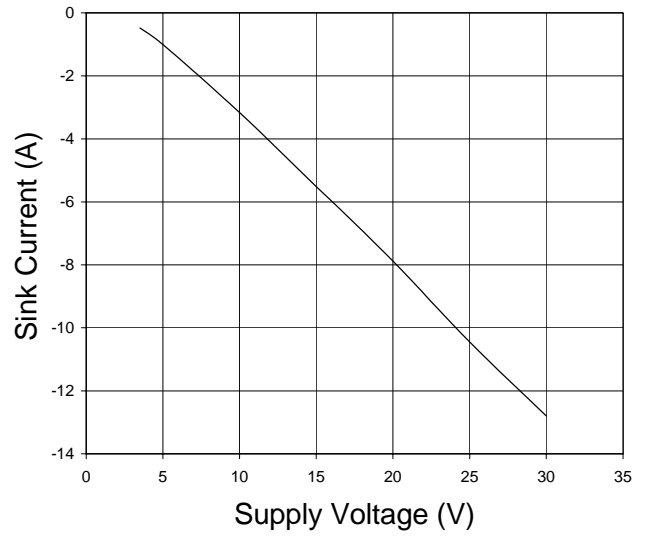
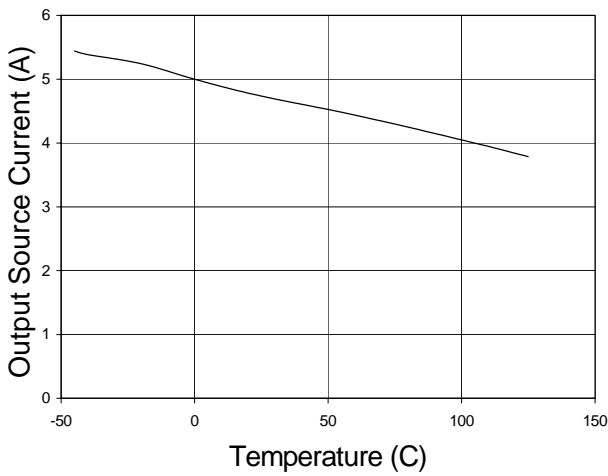
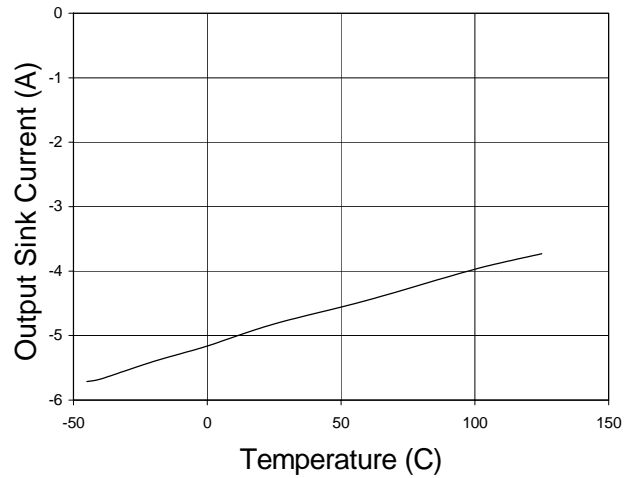
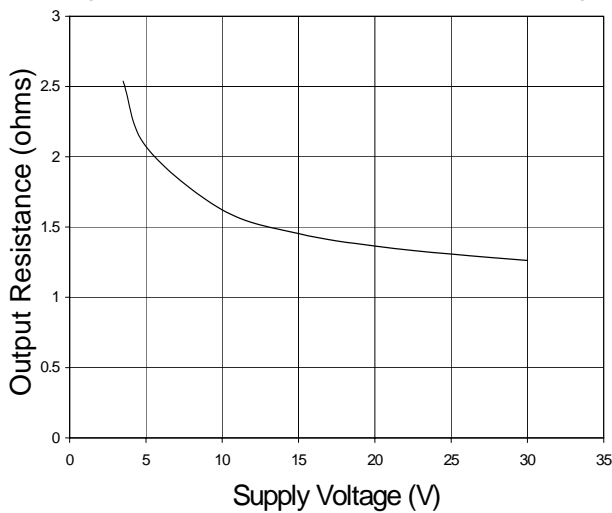
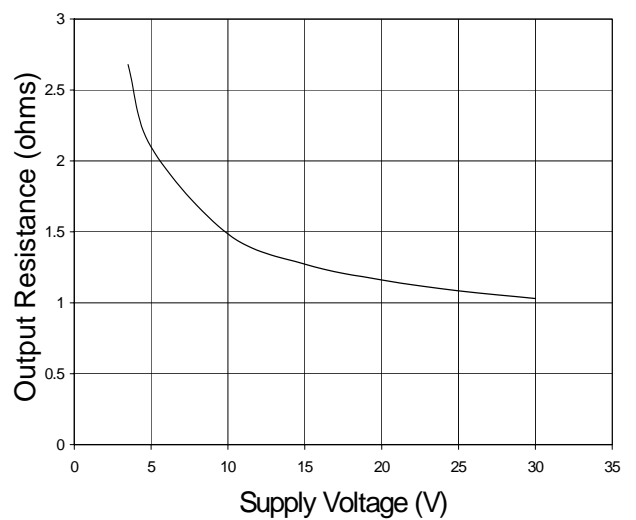
**Fig. 27 Low State Output Resistance vs. Supply Voltage**

Fig. 28

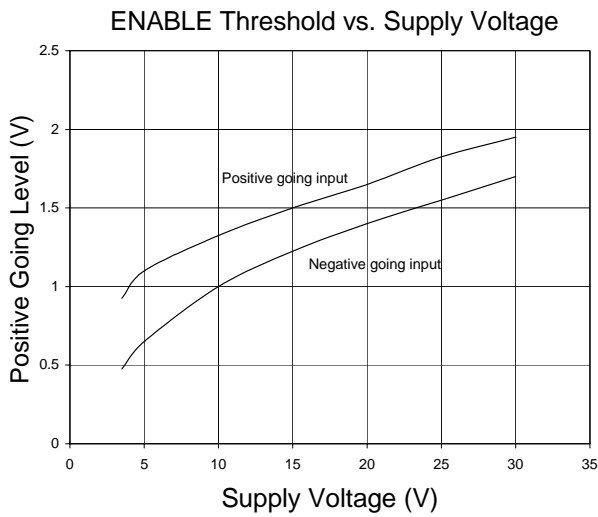

Fig. 29

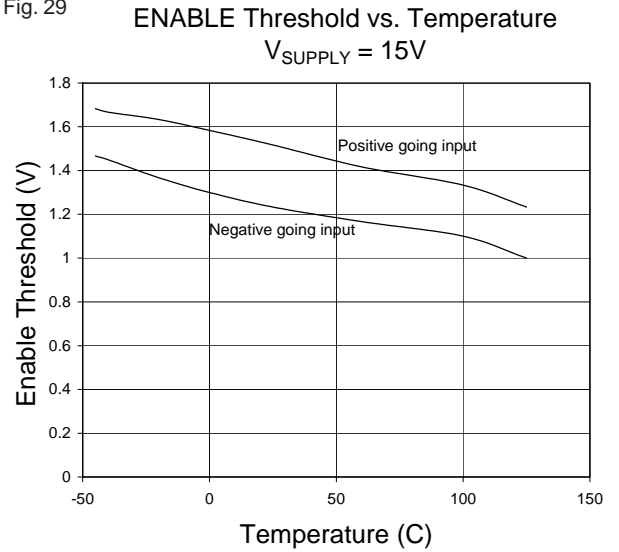

Fig. 30

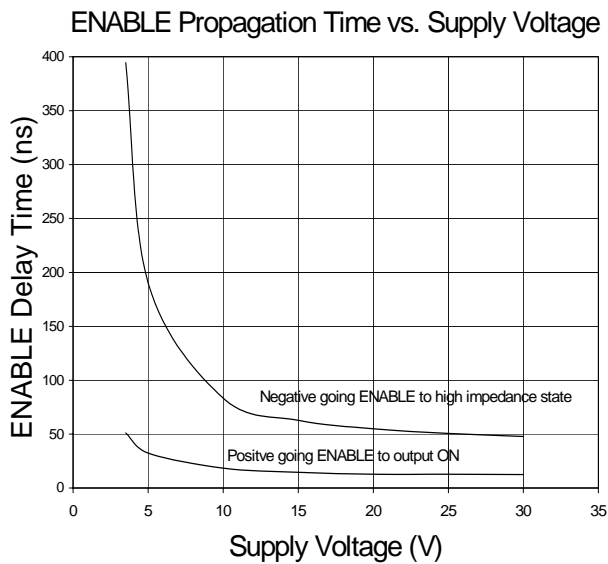
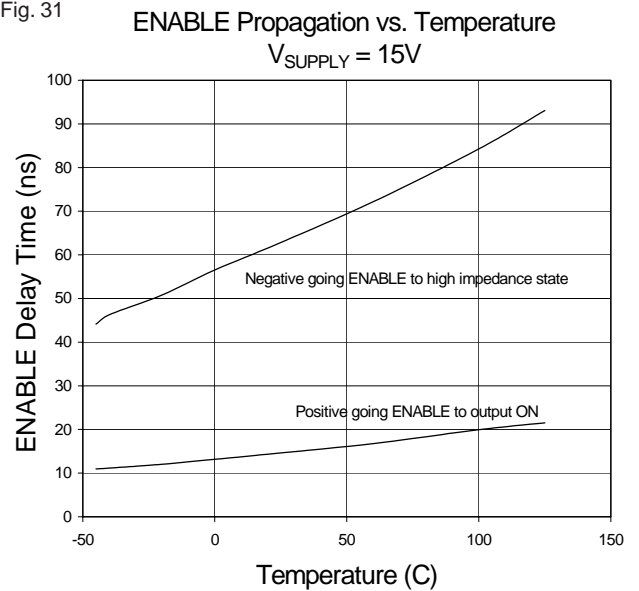
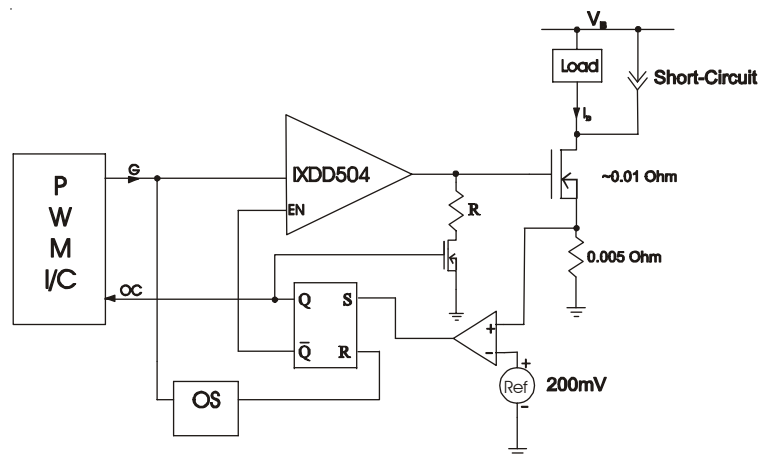

Fig. 31



**Figure 32 - Typical Application Short Circuit di/dt Limit**



## APPLICATIONS INFORMATION

### Short Circuit di/dt Limit

A short circuit in a high-power MOSFET such as the IXFN100N20, (20A, 1000V), as shown in Figure 32, can cause the current through the module to flow in excess of 60A for 10μs or more prior to self-destruction due to thermal runaway. For this reason, some protection circuitry is needed to turn off the MOSFET module. However, if the module is switched off too fast, there is a danger of voltage transients occurring on the drain due to  $L di/dt$ , (where L represents total inductance in series with drain). If these voltage transients exceed the MOSFET's voltage rating, this can cause an avalanche breakdown.

**The IXDD504 and IXDE504 have the unique capability, with additional circuitry, to softly switch off the high-power MOSFET module, significantly reducing these  $L di/dt$  transients.**

Thus, the IXDD504 & IXDE504 help to prevent device destruction from *both* dangers; over-current, *and* avalanche breakdown due to  $di/dt$  induced over-voltage transients.

The IXDD504 & IXDE504 are designed to not only provide  $\pm 4A$  per output under normal conditions, but also to allow their outputs to go into a high impedance state. This permits the IXDD504 or IXDE504 outputs to control a separate weak pull-down circuit during detected overcurrent shutdown conditions to limit and separately control  $d_{V_{GS}}/dt$  gate turnoff. This circuit is shown in Figure 33.

Referring to Figure 33, the protection circuitry should include a comparator, whose positive input is connected to the source of the IXFN100N20. A low pass filter should be added to the

input of the comparator to eliminate any glitches in voltage caused by the inductance of the wire connecting the source resistor to ground. (Those glitches might cause false triggering of the comparator).

The comparator's output should be connected to a SRFF(Set Reset Flip Flop). The flip-flop controls both the Enable signal, and the low power MOSFET gate. Please note that CMOS 4000-series devices operate with a  $V_{CC}$  range from 3 to 15 VDC, (with 18 VDC being the maximum allowable limit).

A low power MOSFET, such as the 2N7002, in series with a resistor, will enable the IXFN100N20 gate voltage to drop gradually. The resistor should be chosen so that the RC time constant will be 100us, where "C" is the Miller capacitance of the IXFN100N20.

For resuming normal operation, a Reset signal is needed at the SRFF's input to enable the IXDD504 again. This Reset can be generated by connecting a One Shot circuit between the IXDD504 Input signal and the SRFF restart input. The One Shot will create a pulse on the rise of the IXDD504 input, and this pulse will reset the SRFF outputs to normal operation.

When a short circuit occurs, the voltage drop across the low-value, current-sensing resistor, ( $R_s=0.005$  Ohm), connected between the MOSFET Source and ground, increases. This triggers the comparator at a preset level. The SRFF drives a low input into the Enable pin disabling the IXDD504 output. The SRFF also turns on the low power MOSFET, (2N7000).

In this way, the high-power MOSFET module is softly turned off by the IXDD504, preventing its destruction.

**Figure 33 - Application Test Diagram**

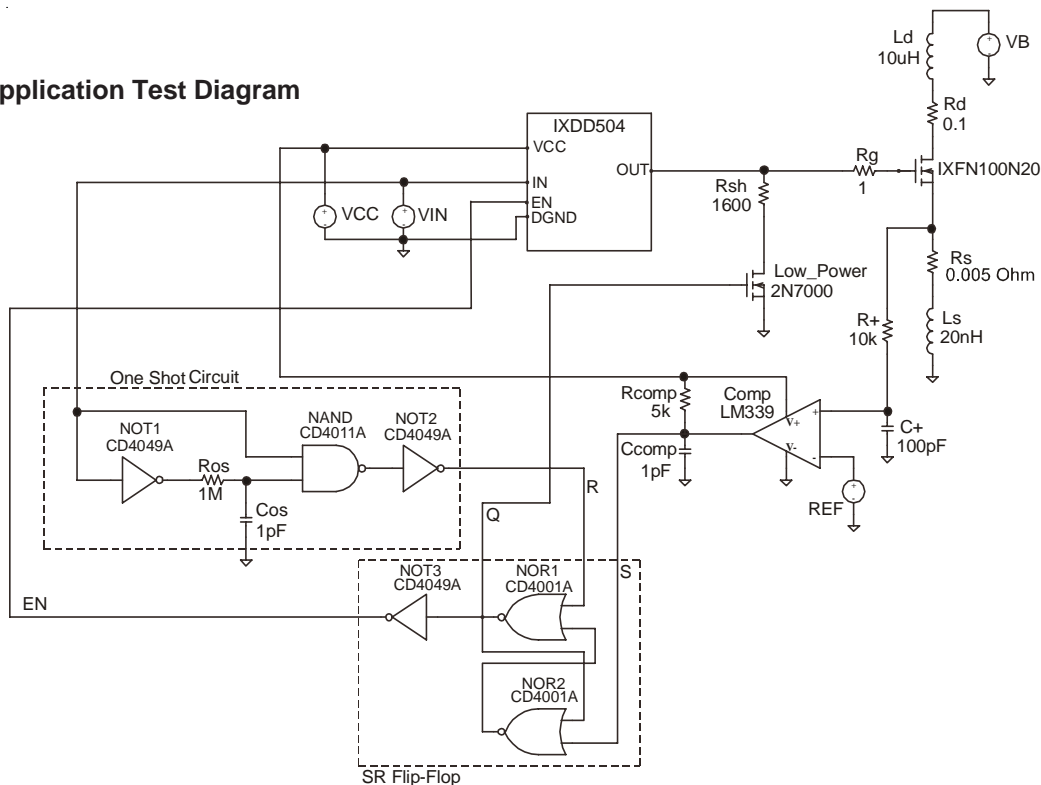

## **Supply Bypassing and Grounding Practices, Output Lead inductance**

When designing a circuit to drive a high speed MOSFET utilizing the IXDD504 or IXDE504, it is very important to keep certain design criteria in mind, in order to optimize performance of the driver. Particular attention needs to be paid to **Supply Bypassing, Grounding,** and minimizing the **Output Lead Inductance.**

Say, for example, we are using the IXDD504 to charge a 2500pF capacitive load from 0 to 25 volts in 25ns.

Using the formula:  $I_c = C (\Delta V / \Delta t)$ , where  $\Delta V=25V$   $C=2500pF$  and  $\Delta t=25ns$  we can determine that to charge 2500pF to 25 volts in 25ns will take a constant current of 2.5A. (In reality, the charging current won't be constant, and will peak somewhere around 4A).

### **SUPPLYBYPASSING**

In order for our design to turn the load on properly, the IXDD504 must be able to draw this 2.5A of current from the power supply in the 25ns. This means that there must be very low impedance between the driver and the power supply. The most common method of achieving this low impedance is to bypass the power supply at the driver with a capacitance value that is a magnitude larger than the load capacitance. Usually, this would be achieved by placing two different types of bypassing capacitors, with complementary impedance curves, very close to the driver itself. (These capacitors should be carefully selected, low inductance, low resistance, high-pulse current-service capacitors). Lead lengths may radiate at high frequency due to inductance, so care should be taken to keep the lengths of the leads between these bypass capacitors and the IXDD504 to an absolute minimum.

### **GROUNDING**

In order for the design to turn the load off properly, the IXDD504 must be able to drain this 2.5A of current into an adequate grounding system. There are three paths for returning current that need to be considered: Path #1 is between the IXDD504 and it's load. Path #2 is between the IXDD504 and it's power supply. Path #3 is between the IXDD504 and whatever logic is driving it. All three of these paths should be as low in resistance and inductance as possible, and thus as short as practical. In addition, every effort should be made to keep these three ground paths distinctly separate. Otherwise, (for instance), the returning ground current from the load may develop a voltage that would have a detrimental effect on the logic line driving the IXDD504.

### **OUTPUTLEADINDUCTANCE**

Of equal importance to Supply Bypassing and Grounding are issues related to the Output Lead Inductance. Every effort should be made to keep the leads between the driver and it's load as short and wide as possible. If the driver must be placed farther than 0.2" from the load, then the output leads should be treated as transmission lines. In this case, a twisted-pair should be considered, and the return line of each twisted pair should be placed as close as possible to the ground pin of the driver, and connect directly to the ground terminal of the load.

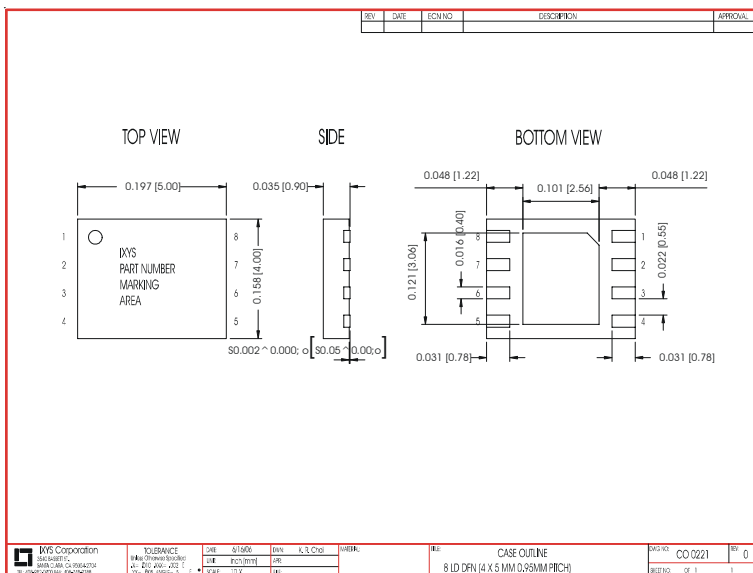
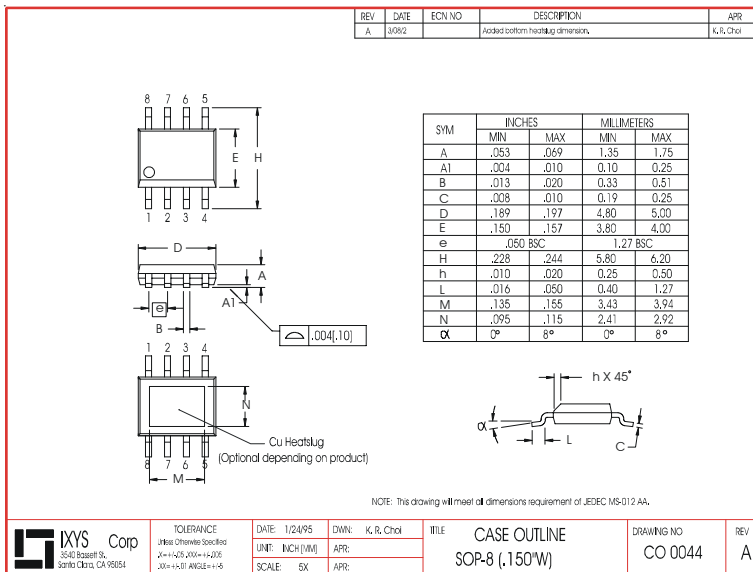
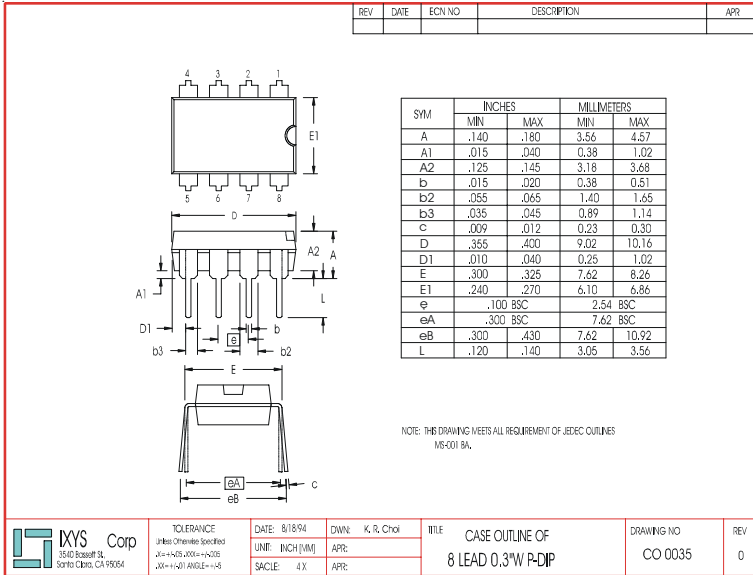

IXYS Corporation  
 3540 Bassett St; Santa Clara, CA 95054  
 Tel: 408-982-0700; Fax: 408-496-0670  
 e-mail: sales@ixys.net  
 www.ixys.com

IXYS Semiconductor GmbH  
 Edisonstrasse 15 ; D-68623; Lampertheim  
 Tel: +49-6206-503-0; Fax: +49-6206-503627  
 e-mail: marcom@ixys.de







## Looking for pricing, stock, or lifecycle information?

Click below to explore more details on WIN SOURCE:

 [View IXDD504PI on WIN SOURCE](#)

 [IXYS Information](#)

## Optimize Your Supply Chain with WIN SOURCE Solutions

-  Global Sourcing Solution
-  Obsolete Management
-  Cost Control Management
-  Shortage Management
-  Alternative Solution
-  Excess Inventory Management