



# THE DATASHEET OF VN820SP-E



### Features

Type	$R_{DS(on)}$	$I_{OUT}$	$V_{CC}$
VN820-E VN820SP-E VN820B5-E VN820PT-E VN820-12-E VN820-11-E	40 m $\Omega$	9 A	36 V

- ECOPACK<sup>®</sup>: lead free and RoHS compliant
- Automotive Grade: compliance with AEC guidelines
- Very low steady current
- CMOS compatible input
- On-state open-load detection
- Off-state open-load detection
- Thermal shutdown protection and diagnosis
- Undervoltage shutdown
- Overvoltage clamp
- Output stuck to  $V_{CC}$  detection
- Load current limitation
- Reverse battery protection
- Electrostatic discharge protection

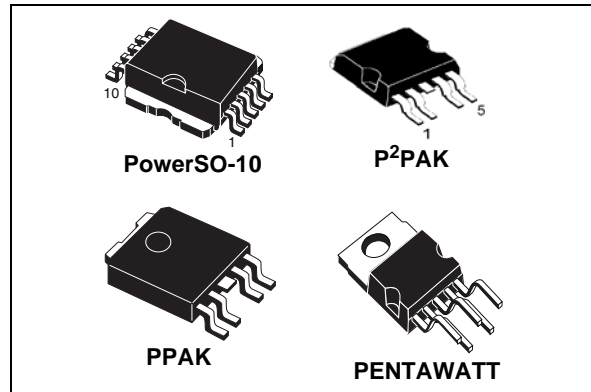

### Description

The VN820-E is a monolithic device designed in STMicroelectronics' VIPower<sup>®</sup> M0-3 technology. The VN820-E is intended for driving any type of load with one side connected to ground. The active  $V_{CC}$  pin voltage clamp protects the device against low energy spikes.

Active current limitation combined with thermal shutdown and automatic restart protect the device against overload. The device detects the open-load condition in both on- and off-state mode. In the off-state the device detects if the output is shorted to  $V_{CC}$ . The device automatically turns off where the ground pin becomes disconnected.

**Table 1. Device summary**

Package	Order codes	
	Tube	Tape and reel
PENTAWATT	VN820-E VN820-12-E VN820-11-E	-
PowerSO-10	VN820SP-E	VN820SPTR-E
P <sup>2</sup> PAK	VN820B5-E	VN820B5TR-E
PPAK	VN820PT-E	VN820PTTR-E

# Contents

<b>1</b>	<b>Block diagram and pin description</b>	<b>7</b>
<b>2</b>	<b>Electrical specifications</b>	<b>8</b>
2.1	Absolute maximum ratings	8
2.2	Thermal data	9
2.3	Electrical characteristics	10
2.4	Electrical characteristics curves	15
<b>3</b>	<b>Application information</b>	<b>18</b>
3.1	GND protection network against reverse battery	18
3.1.1	Solution 1: resistor in the ground line (RGND only)	18
3.1.2	Solution 2: diode (DGND) in the ground line	19
3.2	Load dump protection	19
3.3	MCU I/Os protection	19
3.4	Open-load detection in off-state	19
3.5	PowerSO-10, P <sup>2</sup> PAK, PPAK, PENTAWATT maximum demagnetization energy ( $V_{CC} = 13.5V$ )	21
<b>4</b>	<b>Package and PCB thermal data</b>	<b>22</b>
4.1	P <sup>2</sup> PAK thermal data	22
4.2	PPAK thermal data	25
4.3	PowerSO-10 thermal data	28
<b>5</b>	<b>Package and packing information</b>	<b>31</b>
5.1	ECOPACK <sup>®</sup> packages	31
5.2	PENTAWATT mechanical data	31
5.3	P <sup>2</sup> PAK mechanical data	33
5.4	PPAK mechanical data	35
5.5	PowerSO-10 mechanical data	37
5.6	PENTAWATT packing information	39
5.7	P <sup>2</sup> PAK packing information	39
5.8	PPAK packing information	40

---

5.9	PowerSO-10 packing information .....	42
<b>6</b>	<b>Revision history .....</b>	<b>43</b>

## List of tables

Table 1.	Device summary . . . . .	1
Table 2.	Suggested connections for unused and not connected pins . . . . .	7
Table 3.	Absolute maximum ratings . . . . .	8
Table 4.	Thermal data . . . . .	9
Table 5.	Power . . . . .	10
Table 6.	Switching ( $V_{CC} = 13\text{ V}$ ) . . . . .	10
Table 7.	Input pin . . . . .	11
Table 8.	$V_{CC}$ output diode . . . . .	11
Table 9.	Status pin . . . . .	11
Table 10.	Protections . . . . .	11
Table 11.	Open-load detection . . . . .	12
Table 12.	Truth table . . . . .	13
Table 13.	Electrical transient requirements . . . . .	13
Table 14.	P <sup>2</sup> PAK thermal parameters . . . . .	24
Table 15.	PPAK thermal parameters . . . . .	27
Table 16.	PowerSO-10 thermal parameters . . . . .	30
Table 17.	PENTAWATT mechanical data . . . . .	32
Table 18.	P <sup>2</sup> PAK mechanical data . . . . .	34
Table 19.	PPAK mechanical data . . . . .	36
Table 20.	PowerSO-10 mechanical data . . . . .	38
Table 21.	Document revision history . . . . .	43

## List of figures

Figure 1.	Block diagram . . . . .	7
Figure 2.	Configuration diagram (top view) . . . . .	7
Figure 3.	Current and voltage conventions . . . . .	8
Figure 4.	Status timings . . . . .	12
Figure 5.	Switching time waveforms . . . . .	12
Figure 6.	Waveforms . . . . .	14
Figure 7.	Off-state output current. . . . .	15
Figure 8.	High-level input current. . . . .	15
Figure 9.	Input clamp voltage. . . . .	15
Figure 10.	Status leakage current . . . . .	15
Figure 11.	Status low output voltage . . . . .	15
Figure 12.	Status clamp voltage . . . . .	15
Figure 13.	On-state resistance vs $T_{case}$ . . . . .	16
Figure 14.	On-state resistance vs $V_{CC}$ . . . . .	16
Figure 15.	Open-load on-state detection threshold . . . . .	16
Figure 16.	Input high-level . . . . .	16
Figure 17.	Input low-level. . . . .	16
Figure 18.	Input hysteresis voltage . . . . .	16
Figure 19.	Overvoltage shutdown . . . . .	17
Figure 20.	Open-load off-state voltage detection threshold . . . . .	17
Figure 21.	Turn-on voltage slope . . . . .	17
Figure 22.	Turn-off voltage slope . . . . .	17
Figure 23.	$I_{lim}$ vs $T_{case}$ . . . . .	17
Figure 24.	Application schematic . . . . .	18
Figure 25.	Open-load detection in off-state . . . . .	20
Figure 26.	PowerSO-10, P <sup>2</sup> PAK, PPAK, PENTAWATT maximum turn-off current versus inductance . . . . .	21
Figure 27.	P <sup>2</sup> PAK PC board . . . . .	22
Figure 28.	P <sup>2</sup> PAK $R_{thj-amb}$ vs PCB copper area in open box free air conditions . . . . .	22
Figure 29.	P <sup>2</sup> PAK thermal impedance junction ambient single pulse . . . . .	23
Figure 30.	Thermal fitting model of a single channel HSD in P <sup>2</sup> PAK. . . . .	23
Figure 31.	PPAK PC board . . . . .	25
Figure 32.	PPAK $R_{thj-amb}$ vs PCB copper area in open box free air conditions . . . . .	25
Figure 33.	PPAK thermal impedance junction ambient single pulse . . . . .	26
Figure 34.	Thermal fitting model of a single channel HSD in PPAK . . . . .	26
Figure 35.	PowerSO-10 PC board . . . . .	28
Figure 36.	PowerSO-10 $R_{thj-amb}$ vs PCB copper area in open box free air conditions . . . . .	28
Figure 37.	PowerSO-10 thermal impedance junction ambient single pulse . . . . .	29
Figure 38.	Thermal fitting model of a single channel HSD in PowerSO-10 . . . . .	29
Figure 39.	PENTAWATT package dimensions . . . . .	31
Figure 40.	P <sup>2</sup> PAK package dimensions . . . . .	33
Figure 41.	PPAK package dimensions . . . . .	35
Figure 42.	PowerSO-10 package dimensions . . . . .	37
Figure 43.	PENTAWATT tube shipment (no suffix) . . . . .	39
Figure 44.	P <sup>2</sup> PAK tube shipment (no suffix) . . . . .	39
Figure 45.	P <sup>2</sup> PAK tape and reel (suffix "TR"). . . . .	40
Figure 46.	PPAK suggested pad layout . . . . .	40
Figure 47.	PPAK tube shipment (no suffix) . . . . .	41

---

Figure 48.	PPAK tape and reel (suffix "TR")	41
Figure 49.	PowerSO-10 suggested pad layout	42
Figure 50.	PowerSO-10 tube shipment (no suffix)	42
Figure 51.	PowerSO-10 tape and reel shipment (suffix "TR")	42



## 2 Electrical specifications

Figure 3. Current and voltage conventions

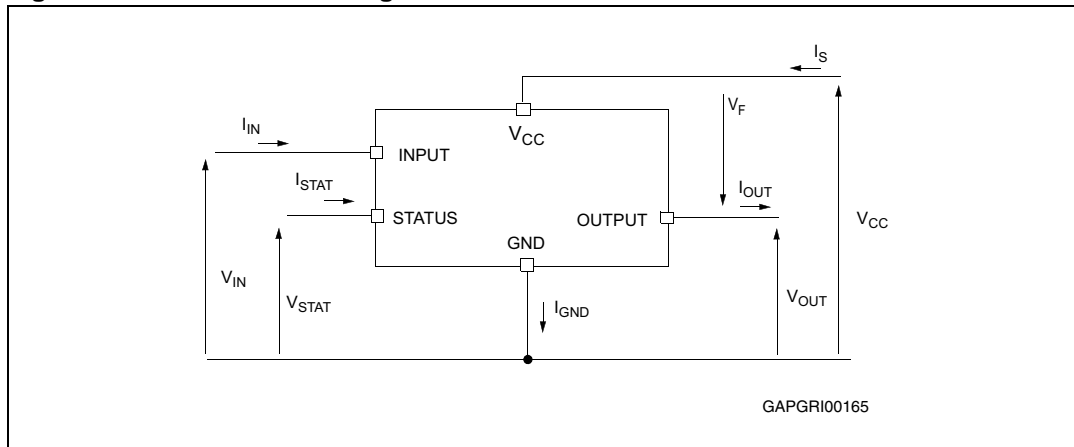

### 2.1 Absolute maximum ratings

Stressing the device above the rating listed in the [Table 3](#) may cause permanent damage to the device. These are stress ratings only and operation of the device at these or any other conditions above those indicated in the operating sections of this specification is not implied. Exposure to Absolute maximum rating conditions for extended periods may affect device reliability.

Table 3. Absolute maximum ratings

Symbol	Parameter	Value				Unit
		PowerSO-10	PENTAWATT	P <sup>2</sup> PAK	PPAK	
V <sub>CC</sub>	DC supply voltage	41				V
-V <sub>CC</sub>	Reverse DC supply voltage	- 0.3				V
-I <sub>gnd</sub>	DC reverse ground pin current	- 200				mA
I <sub>OUT</sub>	DC output current	Internally limited				A
-I <sub>OUT</sub>	Reverse DC output current	- 9				A
I <sub>IN</sub>	DC input current	+/- 10				mA
I <sub>STAT</sub>	DC Status current	+/- 10				mA
V <sub>ESD</sub>	Electrostatic discharge (human body model: R = 1.5 KΩ; C = 100 pF)					
	- INPUT	4000				V
	- STATUS	4000				V
	- OUTPUT	5000				V
	- V <sub>CC</sub>	5000				V

Table 3. Absolute maximum ratings (continued)

Symbol	Parameter	Value				Unit
		PowerSO-10	PENTAWATT	P <sup>2</sup> PAK	PPAK	
$E_{MAX}$	Maximum switching energy ( $L = 1.4 \text{ mH}$ ; $R_L = 0 \Omega$ ; $V_{bat} = 13.5 \text{ V}$ ; $T_{jstart} = 150 \text{ }^\circ\text{C}$ ; $I_L = 13 \text{ A}$ )	156				mJ
$P_{tot}$	Power dissipation $T_C = 25 \text{ }^\circ\text{C}$	65.8				W
$T_j$	Junction operating temperature	Internally limited				$^\circ\text{C}$
$T_C$	Case operating temperature	- 40 to 150				$^\circ\text{C}$
$T_{stg}$	Storage temperature	- 55 to 150				$^\circ\text{C}$

## 2.2 Thermal data

Table 4. Thermal data

Symbol	Parameter	Max. value				Unit
		PowerSO-10	PENTAWATT	P <sup>2</sup> PAK	PPAK	
$R_{thj-case}$	Thermalresistance junction-case	1.9	1.9	1.9	1.9	$^\circ\text{C/W}$
$R_{thj-lead}$	Thermalresistance junction-lead	-	-	-	-	$^\circ\text{C/W}$
$R_{thj-amb}$	Thermalresistance junction-ambient	51.9 <sup>(1)</sup>	61.9 <sup>(2)</sup>	51.9 <sup>(2)</sup>	76.9 <sup>(2)</sup>	$^\circ\text{C/W}$
		37 <sup>(2)</sup>	-	37 <sup>(4)</sup>	45 <sup>(4)</sup>	$^\circ\text{C/W}$

1. When mounted on a standard single-sided FR-4 board with  $0.5\text{cm}^2$  of Cu (at least  $35\mu\text{m}$  thick).
2. When mounted on a standard single-sided FR-4 board with  $6\text{cm}^2$  of Cu (at least  $35\mu\text{m}$  thick).

## 2.3 Electrical characteristics

Values specified in this section are for  $8\text{ V} < V_{CC} < 36\text{ V}$ ;  $-40\text{ }^\circ\text{C} < T_j < 150\text{ }^\circ\text{C}$ , unless otherwise stated.

**Table 5. Power**

Symbol	Parameter	Test conditions	Min.	Typ.	Max.	Unit
$V_{CC}$	Operating supply voltage		5.5	13	36	V
$V_{USD}$	Undervoltage shutdown		3	4	5.5	V
$V_{USDhyst}$	Undervoltage shutdown hysteresis			0.5		V
$V_{OV}$	Overvoltage shutdown		36			V
$R_{ON}$	On-state resistance	$I_{OUT} = 3\text{ A}$ ; $T_j = 25\text{ }^\circ\text{C}$ ; $V_{CC} > 8\text{ V}$ $I_{OUT} = 3\text{ A}$ ; $V_{CC} > 8\text{ V}$			40 80	mΩ mΩ
$I_S$	Supply current	Off-state; $V_{CC} = 13\text{ V}$ ; $V_{IN} = V_{OUT} = 0\text{ V}$		10	25	μA
		Off-state; $V_{CC} = 13\text{ V}$ ; $V_{IN} = V_{OUT} = 0\text{ V}$ ; $T_j = 25\text{ }^\circ\text{C}$		10	20	μA
		On-state; $V_{CC} = 13\text{ V}$ ; $V_{IN} = 5\text{ V}$ ; $I_{OUT} = 0\text{ A}$		2	3.5	mA
$I_{L(off1)}$	Off-state output current	$V_{IN} = V_{OUT} = 0\text{ V}$	0		50	μA
$I_{L(off2)}$	Off-state output current	$V_{IN} = 0\text{ V}$ ; $V_{OUT} = 3.5\text{ V}$	-75		0	μA
$I_{L(off3)}$	Off-state output current	$V_{IN} = V_{OUT} = 0\text{ V}$ ; $V_{CC} = 13\text{ V}$ ; $T_j = 125\text{ }^\circ\text{C}$			5	μA
$I_{L(off4)}$	Off-state output current	$V_{IN} = V_{OUT} = 0\text{ V}$ ; $V_{CC} = 13\text{ V}$ ; $T_j = 25\text{ }^\circ\text{C}$			3	μA

**Table 6. Switching ( $V_{CC} = 13\text{ V}$ )**

Symbol	Parameter	Test conditions	Min.	Typ.	Max.	Unit
$t_{d(on)}$	Turn-on delay time	$R_L = 4.3\text{ }^\Omega$ from $V_{IN}$ rising edge to $V_{OUT} = 1.3\text{ V}$		30		μs
$t_{d(off)}$	Turn-off delay time	$R_L = 4.3\text{ }^\Omega$ from $V_{IN}$ falling edge to $V_{OUT} = 11.7\text{ V}$		30		μs
$dV_{OUT}/dt_{(on)}$	Turn-on voltage slope	$R_L = 4.3\text{ }^\Omega$ from $V_{OUT} = 1.3\text{ V}$ to $V_{OUT} = 10.4\text{ V}$	See <a href="#">Figure 21</a>			V/μs
$dV_{OUT}/dt_{(off)}$	Turn-off voltage slope	$R_L = 4.3\text{ }^\Omega$ from $V_{OUT} = 11.7\text{ V}$ to $V_{OUT} = 1.3\text{ V}$	See <a href="#">Figure 22</a>			V/μs

Table 7. Input pin

Symbol	Parameter	Test conditions	Min.	Typ.	Max.	Unit
$V_{IL}$	Input low-level				1.25	V
$I_{IL}$	Low-level input current	$V_{IN} = 1.25\text{ V}$	1			$\mu\text{A}$
$V_{IH}$	Input high-level		3.25			V
$I_{IH}$	High-level input current	$V_{IN} = 3.25\text{ V}$			10	$\mu\text{A}$
$V_{hyst}$	Input hysteresis voltage		0.5			V
$V_{ICL}$	Input clamp voltage	$I_{IN} = 1\text{ m A}$ $I_{IN} = -1\text{ m A}$	6	6.8 - 0.7	8	V V

Table 8.  $V_{CC}$  output diode

Symbol	Parameter	Test conditions	Min.	Typ.	Max.	Unit
$V_F$	Forward on voltage	$-I_{OUT} = 2\text{ A}; T_j = 150\text{ }^\circ\text{C}$	-	-	0.6	V

Table 9. Status pin

Symbol	Parameter	Test conditions	Min.	Typ.	Max.	Unit
$V_{STAT}$	Status low output voltage	$I_{STAT} = 1.6\text{ mA}$			0.5	V
$I_{LSTAT}$	Status leakage current	Normal operation; $V_{STAT} = 5\text{ V}$			10	$\mu\text{A}$
$C_{STAT}$	Status pin input capacitance	Normal operation; $V_{STAT} = 5\text{ V}$			100	pF
$V_{SCL}$	Status clamp voltage	$I_{STAT} = 1\text{ m A}$ $I_{STAT} = -1\text{ m A}$	6	6.8 - 0.7	8	V V

Table 10. Protections<sup>(1)</sup>

Symbol	Parameter	Test conditions	Min.	Typ.	Max.	Unit
$T_{TSD}$	Shutdown temperature		150	175	200	$^\circ\text{C}$
$T_R$	Reset temperature		135			$^\circ\text{C}$
$T_{hyst}$	Thermal hysteresis		7	15		$^\circ\text{C}$
$t_{SDL}$	Status delay in overload condition	$T_j > T_{jsh}$			20	ms
$I_{lim}$	Current limitation	$9\text{ V} < V_{CC} < 36\text{ V}$ $5.5\text{ V} < V_{CC} < 36\text{ V}$	9	13	20 20	A A
$V_{demag}$	Turn-off output clamp voltage	$I_{OUT} = 3\text{ A};$ $V_{IN} = 0\text{ V};$ $L = 6\text{ mH}$	$V_{CC} - 41$	$V_{CC} - 48$	$V_{CC} - 55$	V

1. To ensure long term reliability under heavy overload or short circuit conditions, protection and related diagnostic signals must be used together with a proper software strategy. If the device operates under abnormal conditions this software must limit the duration and number of activation cycles.

**Table 11. Open-load detection**

Symbol	Parameter	Test conditions	Min.	Typ.	Max.	Unit
$I_{OL}$	Open-load on-state detection threshold	$V_{IN} = 5\text{ V}$	70	150	300	mA
$t_{DOL(on)}$	Open-load on-state detection delay	$I_{OUT} = 0\text{ A}$			200	$\mu\text{s}$
$V_{OL}$	Open-load off-state voltage detection threshold	$V_{IN} = 0\text{ V}$	1.5	2.5	3.5	V
$t_{DOL(off)}$	Open-load detection delay at turn-off				1000	$\mu\text{s}$

**Figure 4. Status timings**

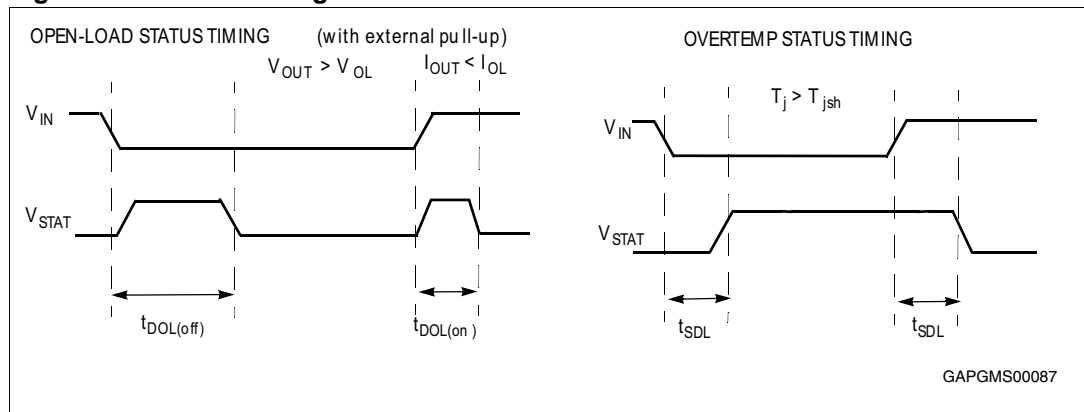

**Figure 5. Switching time waveforms**

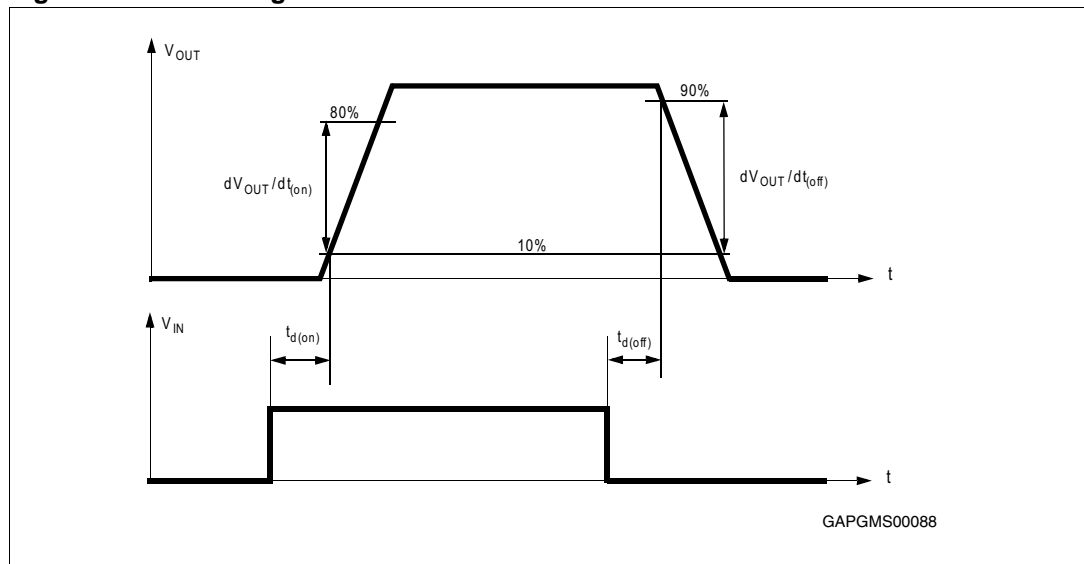

Table 12. Truth table

Conditions	Input	Output	Status
Normal operation	L	L	H
	H	H	H
Current limitation	L	L	H
	H	X	$(T_j < T_{TSD})$ H
	H	X	$(T_j > T_{TSD})$ L
Overtemperature	L	L	H
	H	L	L
Undervoltage	L	L	X
	H	L	X
Overvoltage	L	L	H
	H	L	H
Output voltage $> V_{OL}$	L	H	L
	H	H	H
Output current $< I_{OL}$	L	L	H
	H	H	L

Table 13. Electrical transient requirements

ISO T/R 7637/1 Test pulse	Test level				Delays and impedance
	I	II	III	IV	
1	- 25V <sup>(1)</sup>	- 50V <sup>(1)</sup>	- 75V <sup>(1)</sup>	- 100V <sup>(1)</sup>	2ms, 10Ω
2	+ 25V <sup>(1)</sup>	+ 50V <sup>(1)</sup>	+ 75V <sup>(1)</sup>	+ 100V <sup>(1)</sup>	0.2ms, 10Ω
3a	- 25V <sup>(1)</sup>	- 50V <sup>(1)</sup>	- 100V <sup>(1)</sup>	- 150V <sup>(1)</sup>	0.1μs, 50Ω
3b	+ 25V <sup>(1)</sup>	+ 50V <sup>(1)</sup>	+ 75V <sup>(1)</sup>	+ 100V <sup>(1)</sup>	0.1μs, 50Ω
4	- 4V <sup>(1)</sup>	- 5V <sup>(1)</sup>	- 6V <sup>(1)</sup>	- 7V <sup>(1)</sup>	100ms, 0.01Ω
5	+ 26.5V <sup>(1)</sup>	+ 46.5V <sup>(2)</sup>	+ 66.5V <sup>(2)</sup>	+ 86.5V <sup>(2)</sup>	400ms, 2Ω

1. All functions of the device are performed as designed after exposure to disturbance.
2. One or more functions of the device is not performed as designed after exposure and cannot be returned to proper operation without replacing the device.

Figure 6. Waveforms

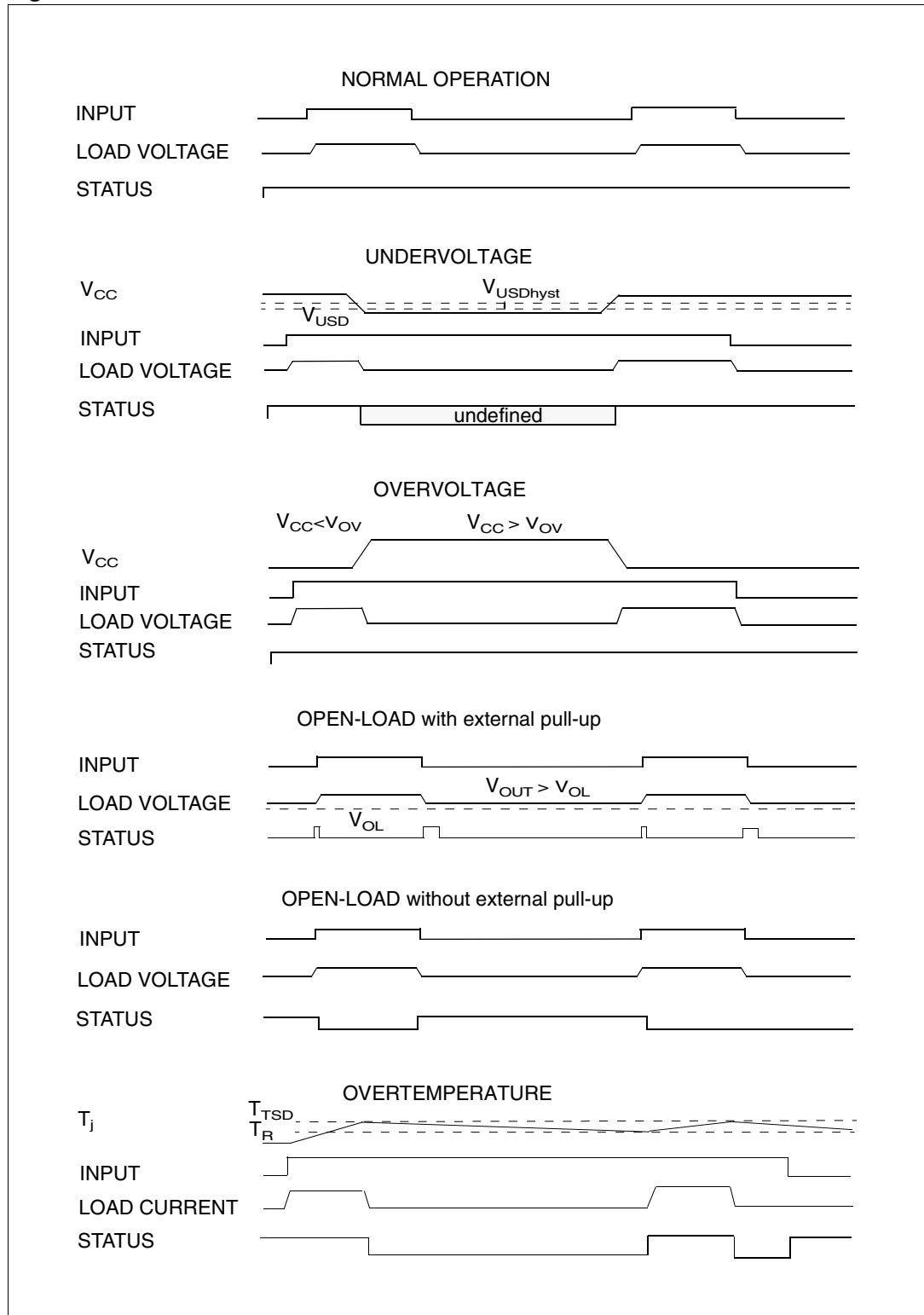

## 2.4 Electrical characteristics curves

**Figure 7. Off-state output current**

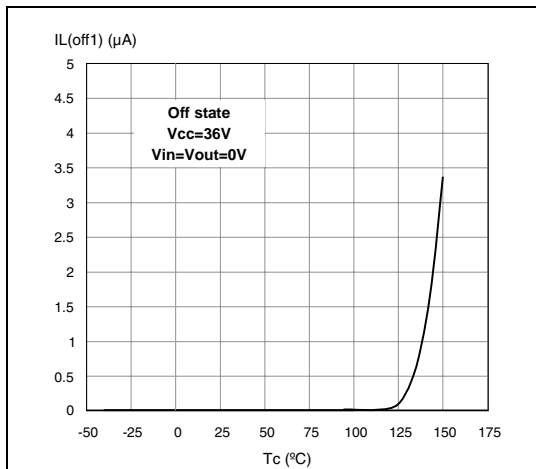

**Figure 8. High-level input current**

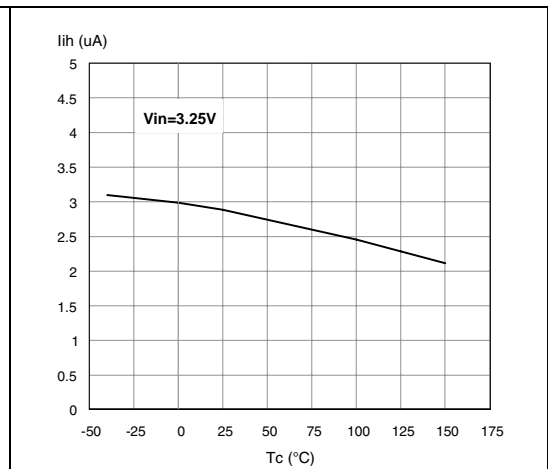

**Figure 9. Input clamp voltage**

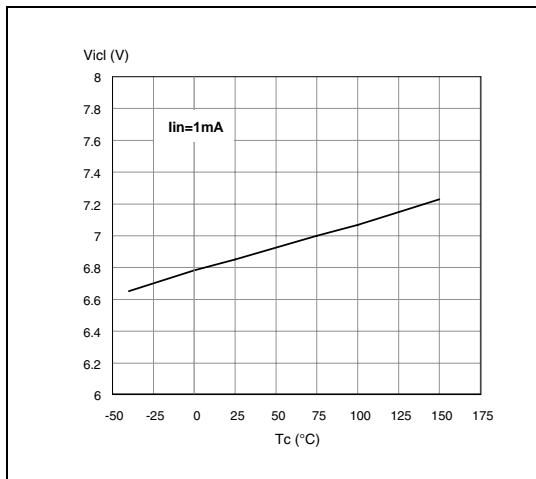

**Figure 10. Status leakage current**

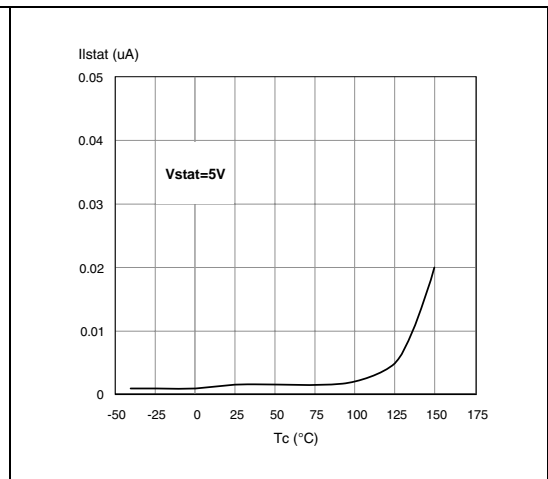

**Figure 11. Status low output voltage**

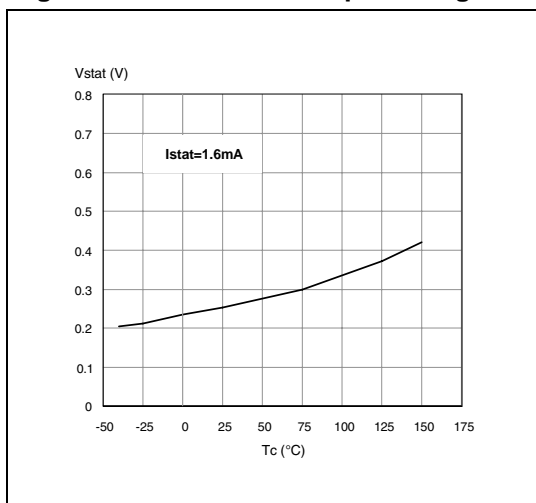

**Figure 12. Status clamp voltage**

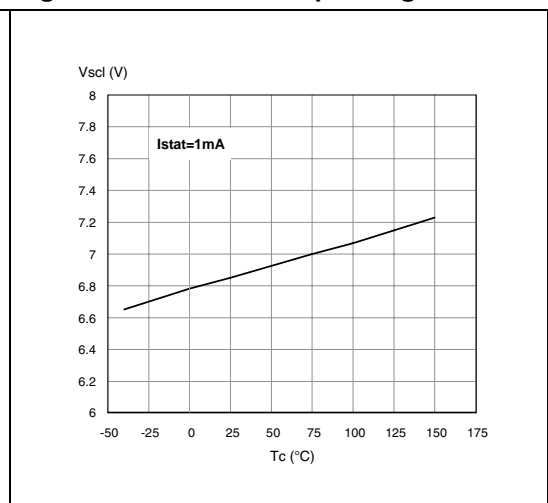

Figure 13. On-state resistance vs  $T_{case}$

Figure 14. On-state resistance vs  $V_{CC}$

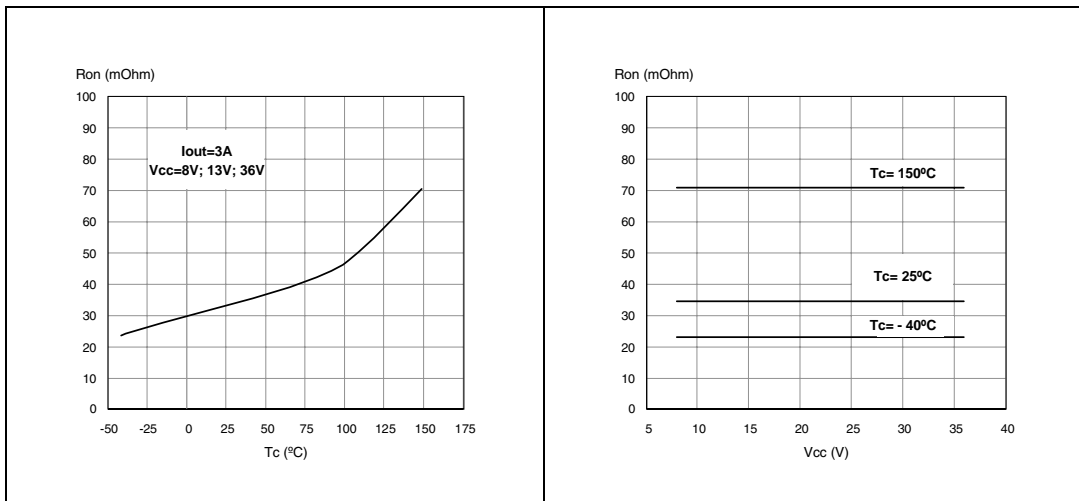

Figure 15. Open-load on-state detection

Figure 16. Input high-level threshold

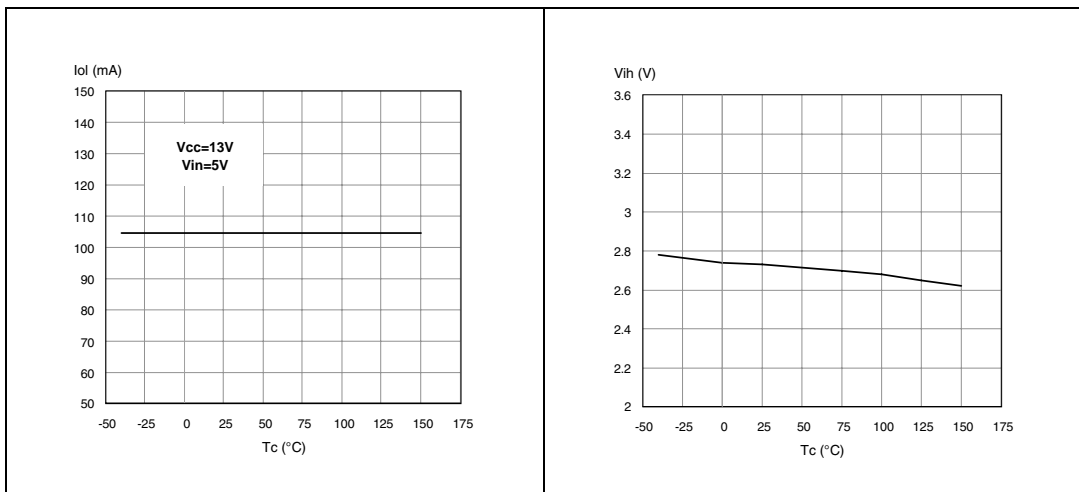

Figure 17. Input low-level

Figure 18. Input hysteresis voltage

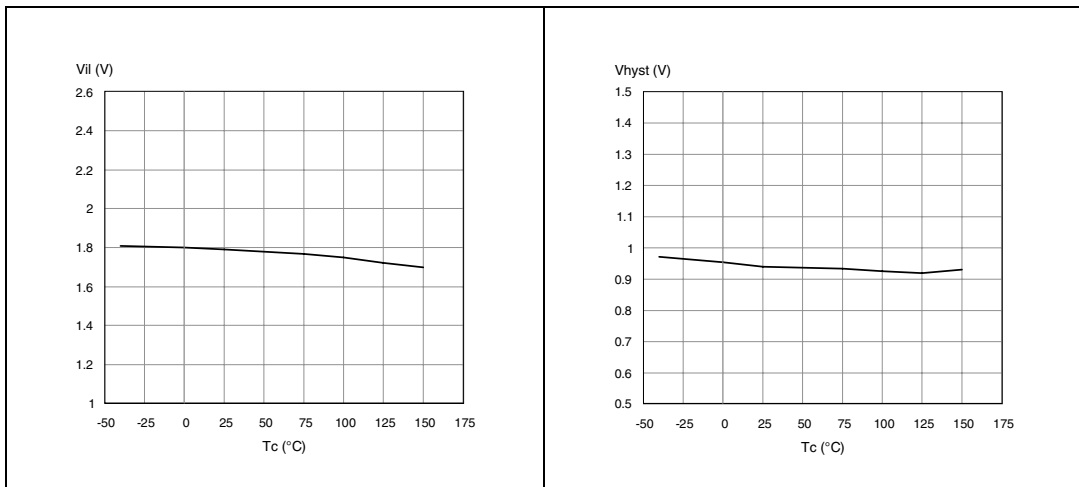

Figure 19. Overtoltage shutdown

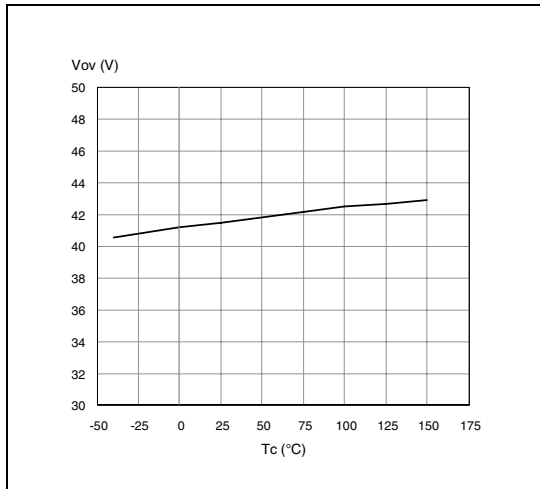

Figure 20. Open-load off-state voltage detection threshold

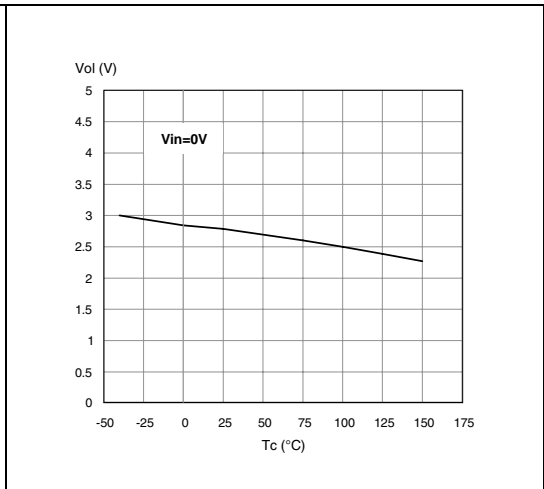

Figure 21. Turn-on voltage slope

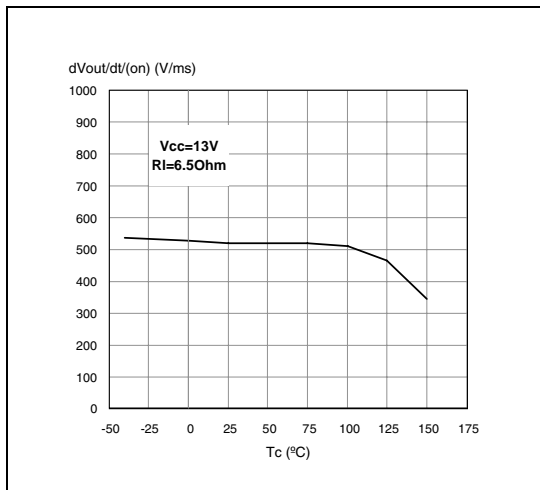

Figure 22. Turn-off voltage slope

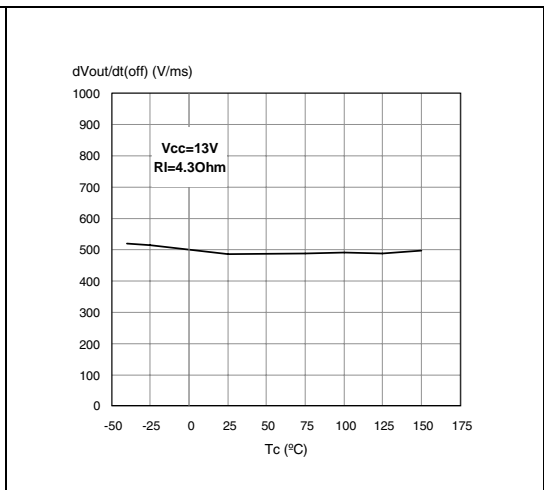
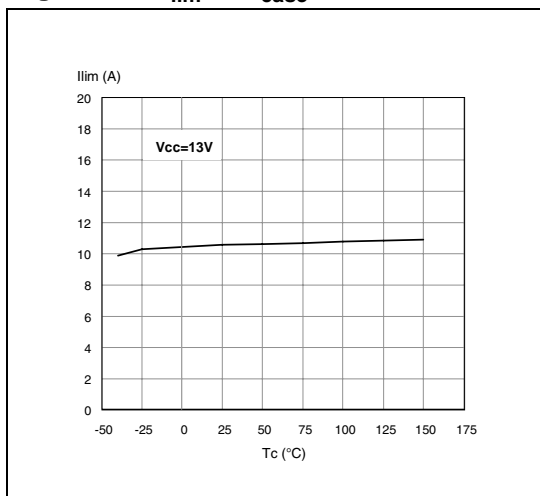
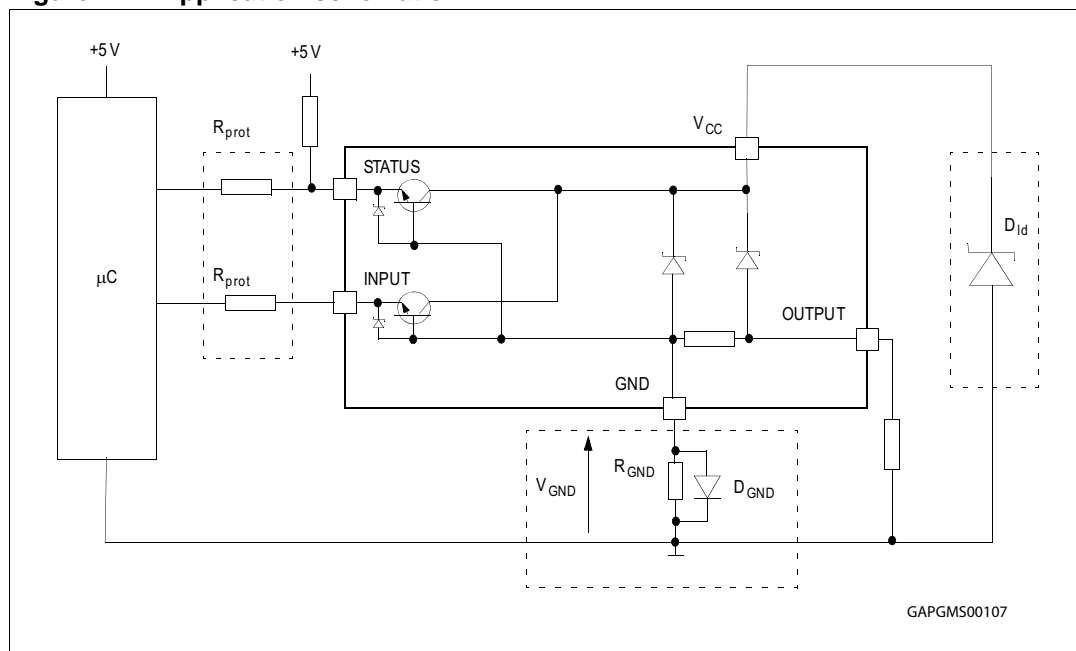

Figure 23. Ilim vs Tcase



### 3 Application information

Figure 24. Application schematic



#### 3.1 GND protection network against reverse battery

##### 3.1.1 Solution 1: resistor in the ground line (R\_GND only)

This can be used with any type of load.

The following is an indication on how to set a dimension the R\_GND resistor.

1.  $R_{GND} \leq 600 \text{ mV} / (I_{S(on)max})$ .
2.  $R_{GND} \geq (-V_{CC}) / (-I_{GND})$

where  $-I_{GND}$  is the DC reverse ground pin current and can be found in the absolute maximum rating section of the device datasheet.

Power Dissipation in R\_GND (when  $V_{CC} < 0$ : during reverse battery situations) is:

$$P_D = (-V_{CC})^2 / R_{GND}$$

This resistor can be shared amongst several different HSDs. Please note that the value of this resistor should be calculated with formula (1) where  $I_{S(on)max}$  becomes the sum of the maximum on-state currents of the different devices.

Please note that if the microprocessor ground is not shared by the device ground then the R\_GND produces a shift ( $I_{S(on)max} * R_{GND}$ ) in the input thresholds and the status output values. This shift does not vary depending on how many devices are ON in case of several high-side drivers sharing the same R\_GND.

If the calculated power dissipation leads to a large resistor or several devices have to share the same resistor then ST suggests to utilize Solution 2 (see below).

### 3.1.2 Solution 2: diode ( $D_{GND}$ ) in the ground line

A resistor ( $R_{GND} = 1k\Omega$ ) should be inserted in parallel to  $D_{GND}$  if the device drives an inductive load.

This small signal diode can be safely shared amongst several different HSDs. Also in this case, the presence of the ground network produces a shift ( $\approx 600$  mV) in the input threshold and in the status output values if the microprocessor ground is not common to the device ground. This shift not varies if more than one HSD shares the same diode/resistor network.

Series resistor in INPUT and STATUS lines are also required to prevent that, during battery voltage transient, the current exceeds the absolute maximum rating.

The safest configuration for unused INPUT and STATUS pin is to leave them unconnected.

## 3.2 Load dump protection

$D_{ld}$  is necessary (Voltage Transient Suppressor) if the load dump peak voltage exceeds the  $V_{CC}$  max DC rating. The same applies if the device is subject to transients on the  $V_{CC}$  line that are greater than the ones shown in the ISO 7637-2: 2004(E) table.

## 3.3 MCU I/Os protection

If a ground protection network is used and negative transients are present on the  $V_{CC}$  line, the control pins are pulled negative. ST suggests to insert a resistor ( $R_{prot}$ ) in line to prevent the microcontroller I/Os pins from latching-up.

The value of these resistors is a compromise between the leakage current of microcontroller and the current required by the HSD I/Os (Input levels compatibility) with the latch-up limit of  $\mu C$  I/Os.

$$-V_{CCpeak}/I_{latchup} \leq R_{prot} \leq (V_{OH\mu C} - V_{IH} - V_{GND}) / I_{IHmax}$$

Calculation example:

For  $V_{CCpeak} = -100$  V and  $I_{latchup} \geq 20$  mA;  $V_{OH\mu C} \geq 4.5$  V

$$5 \text{ k}\Omega \leq R_{prot} \leq 65 \text{ k}\Omega$$

Recommended values:  $R_{prot} = 10 \text{ k}\Omega$ .

## 3.4 Open-load detection in off-state

Off-state open-load detection requires an external pull-up resistor ( $R_{PU}$ ) connected between OUTPUT pin and a positive supply voltage ( $V_{PU}$ ) like the +5 V line used to supply the microprocessor.

The external resistor has to be selected according to the following requirements:

- no false open-load indication when load is connected: in this case we have to avoid  $V_{OUT}$  to be higher than  $V_{OLmin}$ ; this results in the following condition  

$$V_{OUT} = (V_{PU} / (R_L + R_{PU})) R_L < V_{OLmin}$$
- no misdetection when load is disconnected: in this case the  $V_{OUT}$  has to be higher than  $V_{OLmax}$ ; this results in the following condition  $R_{PU} < (V_{PU} - V_{OLmax}) / I_{L(off2)}$ .

Because  $I_{S(OFF)}$  may significantly increase if  $V_{out}$  is pulled high (up to several mA), the pull-up resistor  $R_{PU}$  should be connected to a supply that is switched off when the module is in standby.

The values of  $V_{OLmin}$ ,  $V_{OLmax}$  and  $I_{L(off2)}$  are available in the electrical characteristics section.

**Figure 25. Open-load detection in off-state**

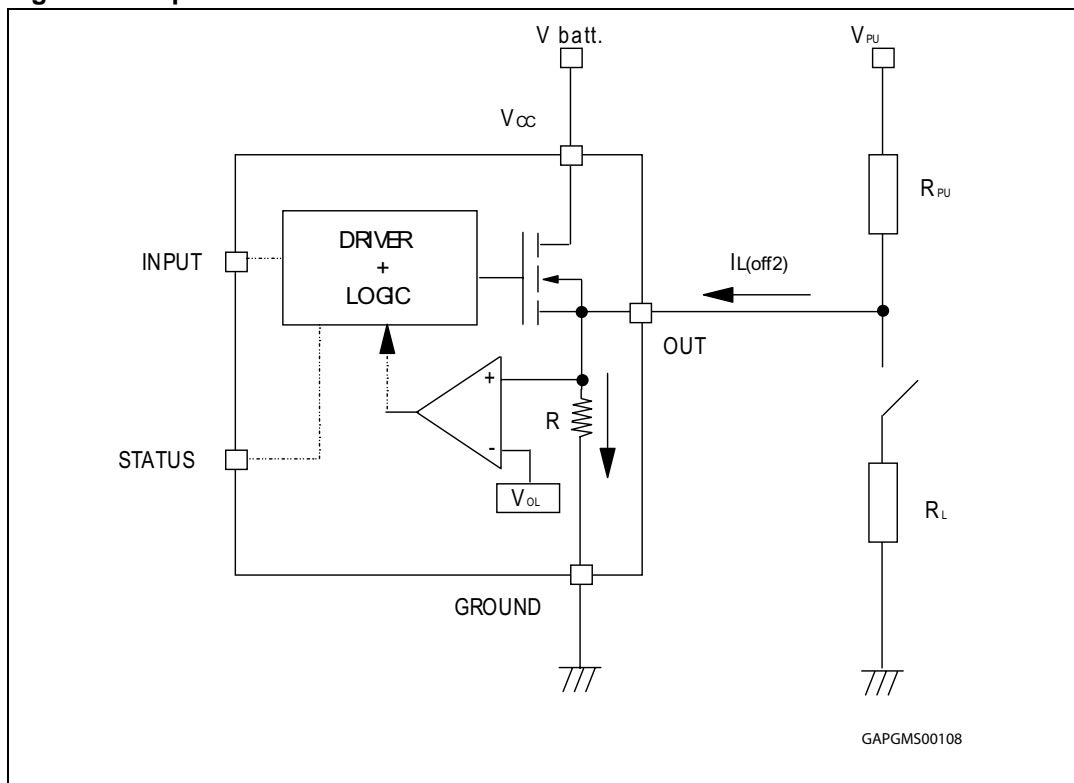

### 3.5 PowerSO-10, P<sup>2</sup>PAK, PPAK, PENTAWATT maximum demagnetization energy ( $V_{CC} = 13.5V$ )

Figure 26. PowerSO-10, P<sup>2</sup>PAK, PPAK, PENTAWATT maximum turn-off current versus inductance

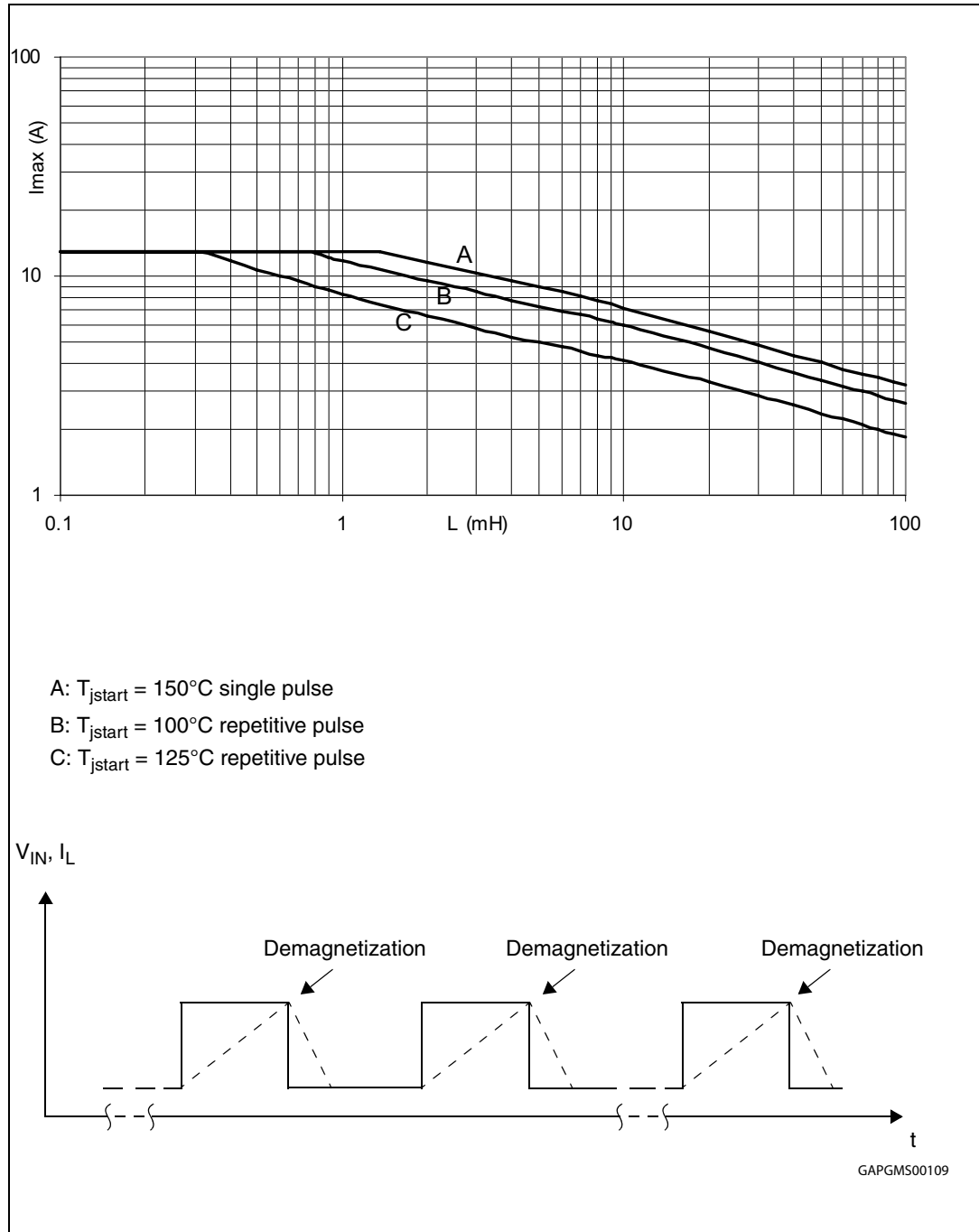

Note: Values are generated with  $R_L = 0 \Omega$ . In case of repetitive pulses,  $T_{jstart}$  (at beginning of each demagnetization) of every pulse must not exceed the temperature specified above for curves A and B.

## 4 Package and PCB thermal data

### 4.1 P<sup>2</sup>PAK thermal data

Figure 27. P<sup>2</sup>PAK PC board

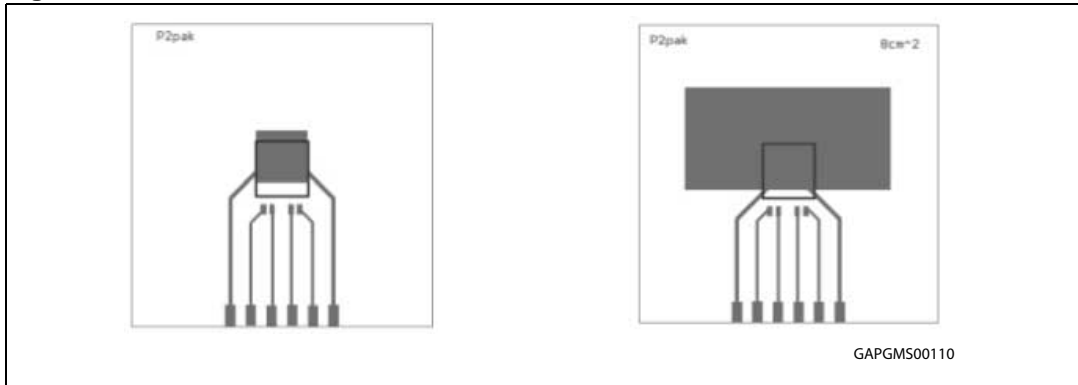

Note: Layout condition of  $R_{th}$  and  $Z_{th}$  measurements (PCB FR4 area = 60 mm x 60 mm, PCB thickness = 2 mm, Cu thickness = 35  $\mu$ m , Copper areas: 0.97 cm<sup>2</sup>, 8 cm<sup>2</sup>).

Figure 28. P<sup>2</sup>PAK  $R_{thj-amb}$  vs PCB copper area in open box free air conditions

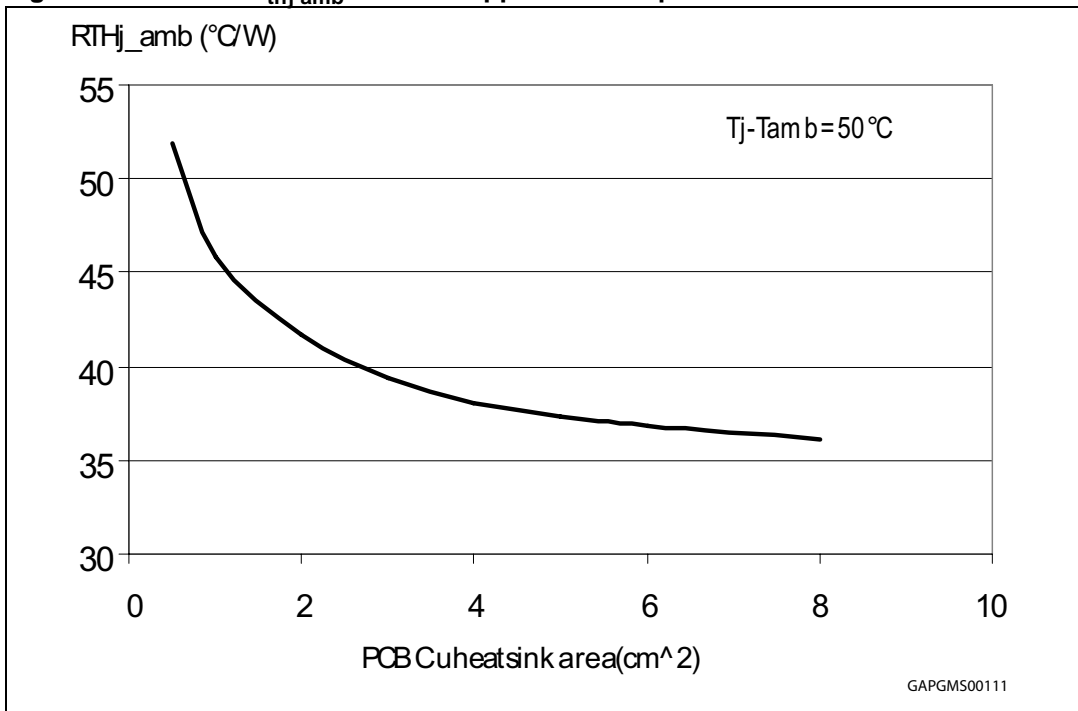
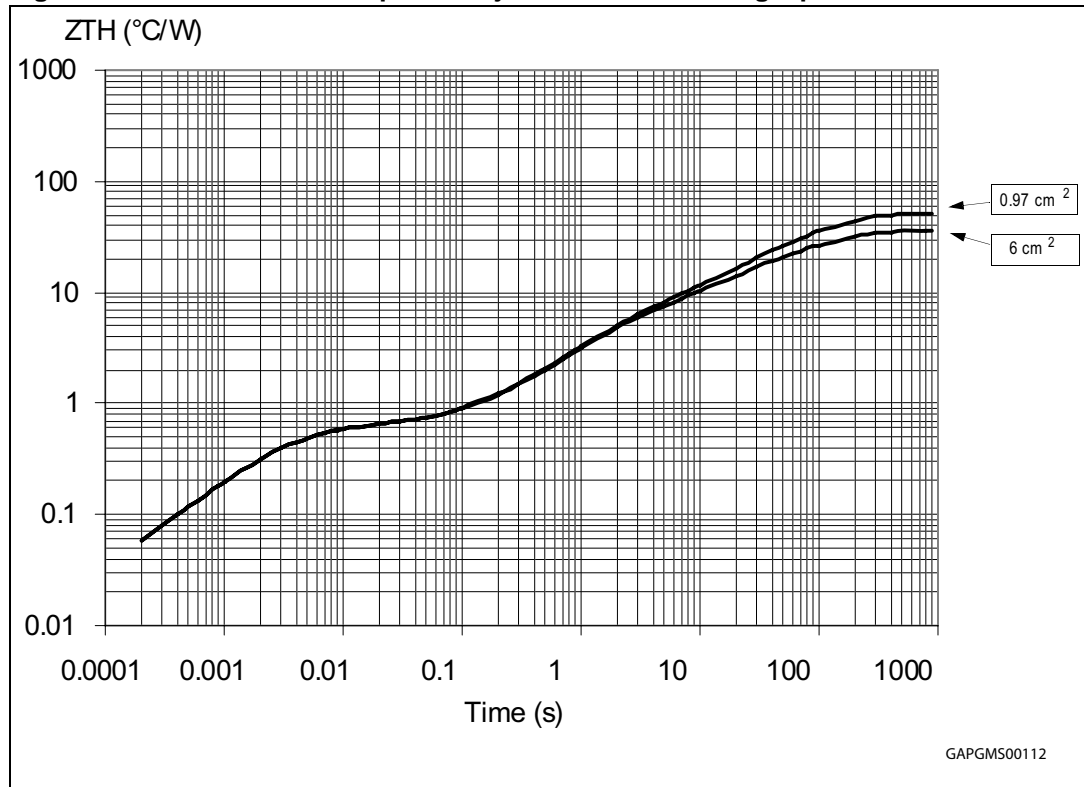

Figure 29. P<sup>2</sup>PAK thermal impedance junction ambient single pulse



Equation 1: pulse calculation formula

$$Z_{TH\delta} = R_{TH} \cdot \delta + Z_{THtp}(1 - \delta)$$

where  $\delta = t_p/T$

Figure 30. Thermal fitting model of a single channel HSD in P<sup>2</sup>PAK

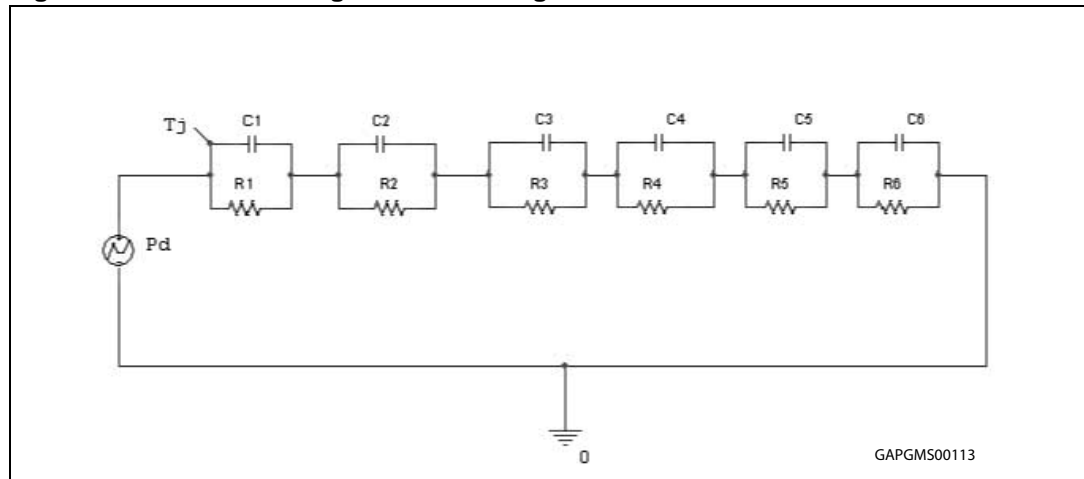
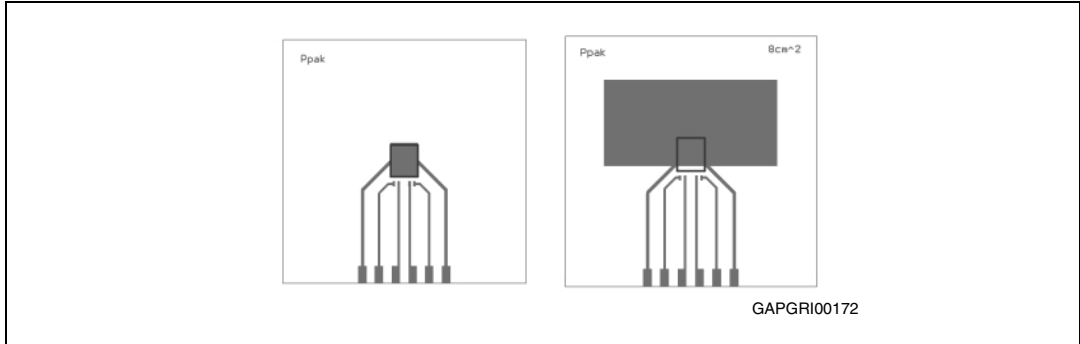

Table 14. P<sup>2</sup>PAK thermal parameters

Area/island (cm <sup>2</sup> )	0.97	6
R1 (°C/W)	0.04	
R2 (°C/W)	0.25	
R3 (°C/W)	0.3	
R4 (°C/W)	4	
R5 (°C/W)	9	
R6 (°C/W)	37	22
C1 (W·s/°C)	0.0008	
C2 (W·s/°C)	0.007	
C3 (W·s/°C)	0.015	
C4 (W·s/°C)	0.4	
C5 (W·s/°C)	2	
C6 (W·s/°C)	3	5

## 4.2 PPAK thermal data

Figure 31. PPAK PC board



Note: Layout condition of  $R_{th}$  and  $Z_{th}$  measurements (PCB FR4 area = 60 mm x 60 mm, PCB thickness = 2 mm, Cu thickness=35  $\mu$ m , Copper areas: 0.44 cm<sup>2</sup>, 8 cm<sup>2</sup>).

Figure 32. PPAK  $R_{thj-amb}$  vs PCB copper area in open box free air conditions

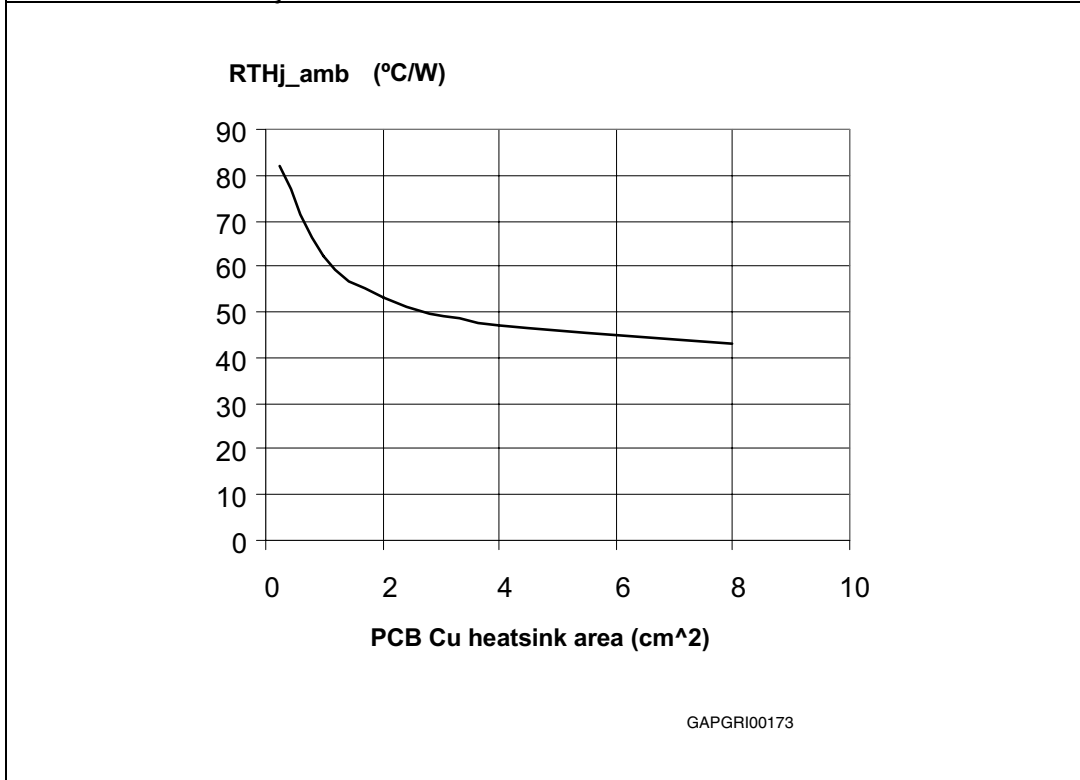
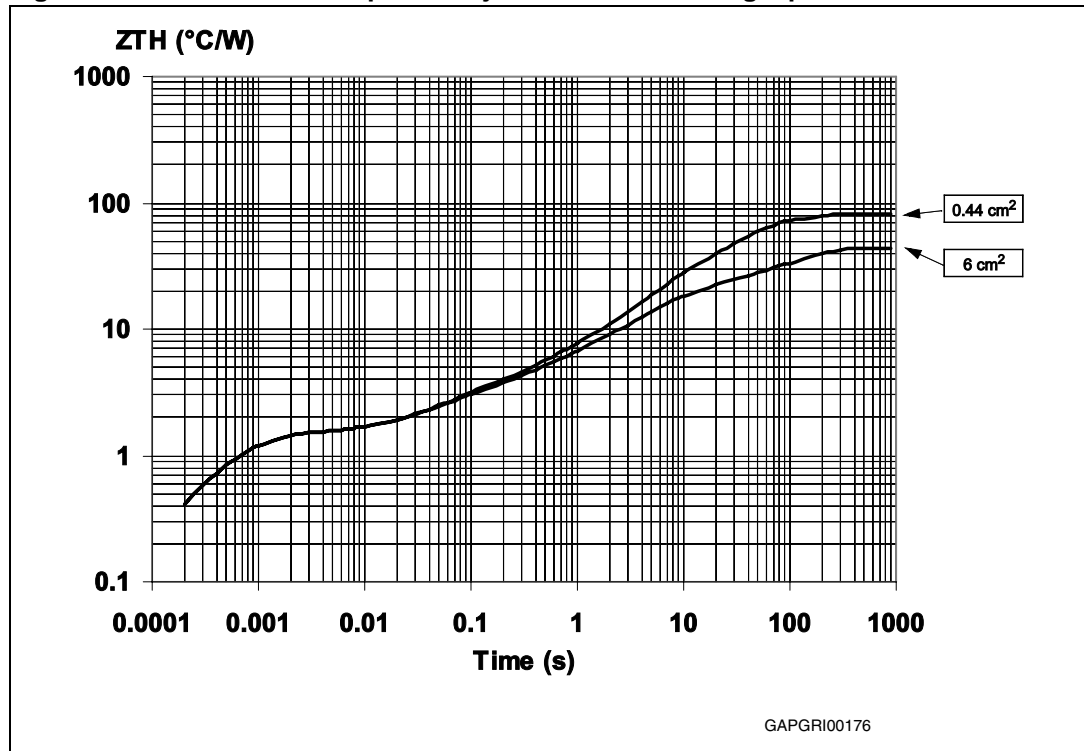

Figure 33. PPAK thermal impedance junction ambient single pulse



Equation 2: pulse calculation formula

$$Z_{TH\delta} = R_{TH} \cdot \delta + Z_{THtp}(1 - \delta)$$

where  $\delta = t_p/T$

Figure 34. Thermal fitting model of a single channel HSD in PPAK

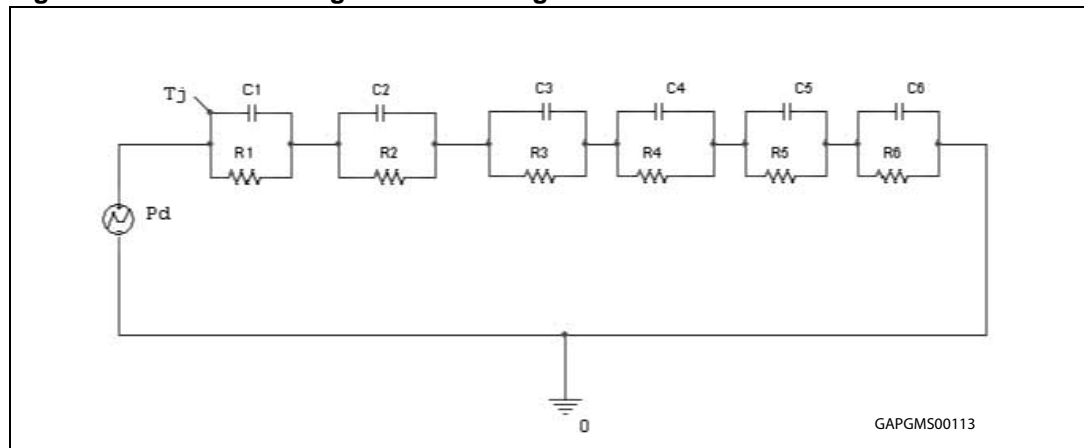
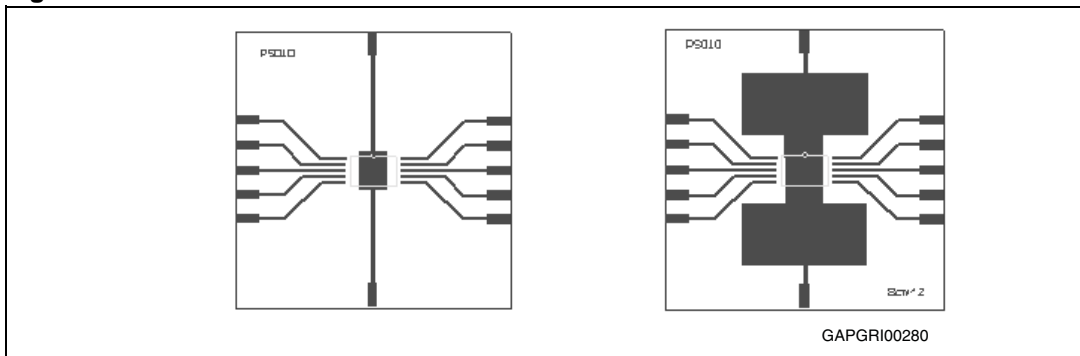

Table 15. PPAK thermal parameters

Area/island (cm <sup>2</sup> )	0.44	6
R1 (°C/W)	0.04	
R2 (°C/W)	0.25	
R3 (°C/W)	0.3	
R4 (°C/W)	2	
R5 (°C/W)	15	
R6 (°C/W)	61	24
C1 (W·s/°C)	0.0008	
C2 (W·s/°C)	0.007	
C3 (W·s/°C)	0.02	
C4 (W·s/°C)	0.3	
C5 (W·s/°C)	0.45	
C6 (W·s/°C)	0.8	5

### 4.3 PowerSO-10 thermal data

Figure 35. PowerSO-10 PC board



Note: Layout condition of  $R_{th}$  and  $Z_{th}$  measurements (PCB FR4 area = 58 mm x 58 mm, PCB thickness = 2 mm, Cu thickness = 35  $\mu$ m, Copper areas: from minimum pad lay-out to 8 cm<sup>2</sup>).

Figure 36. PowerSO-10  $R_{thj-amb}$  vs PCB copper area in open box free air conditions

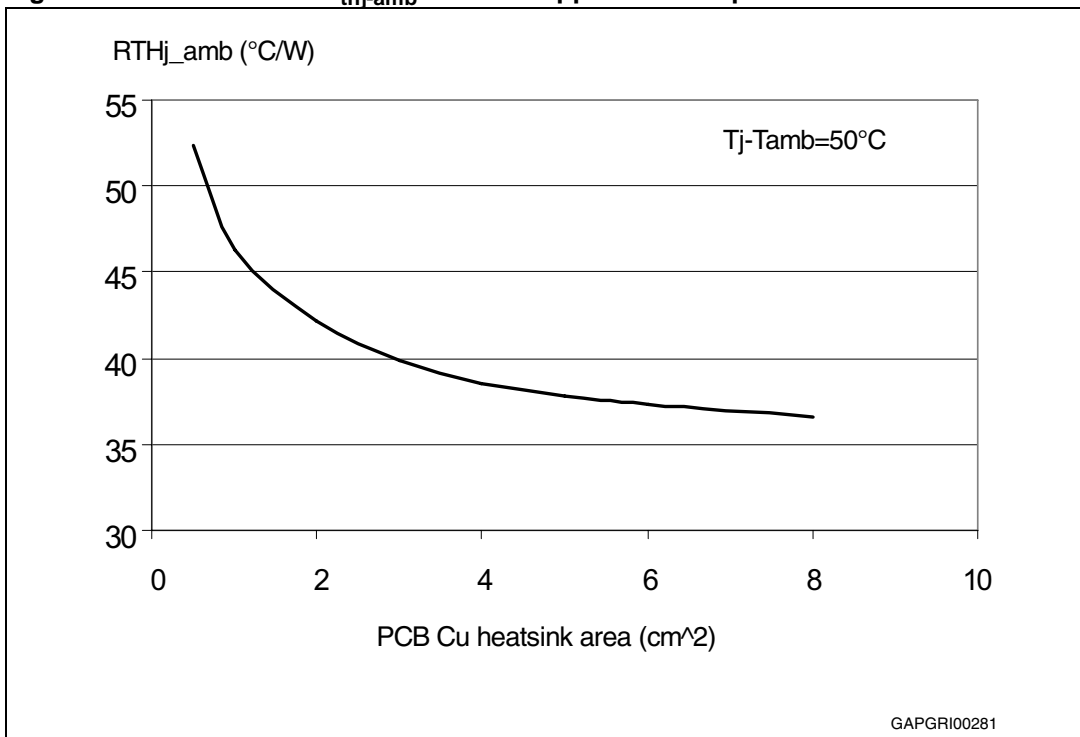
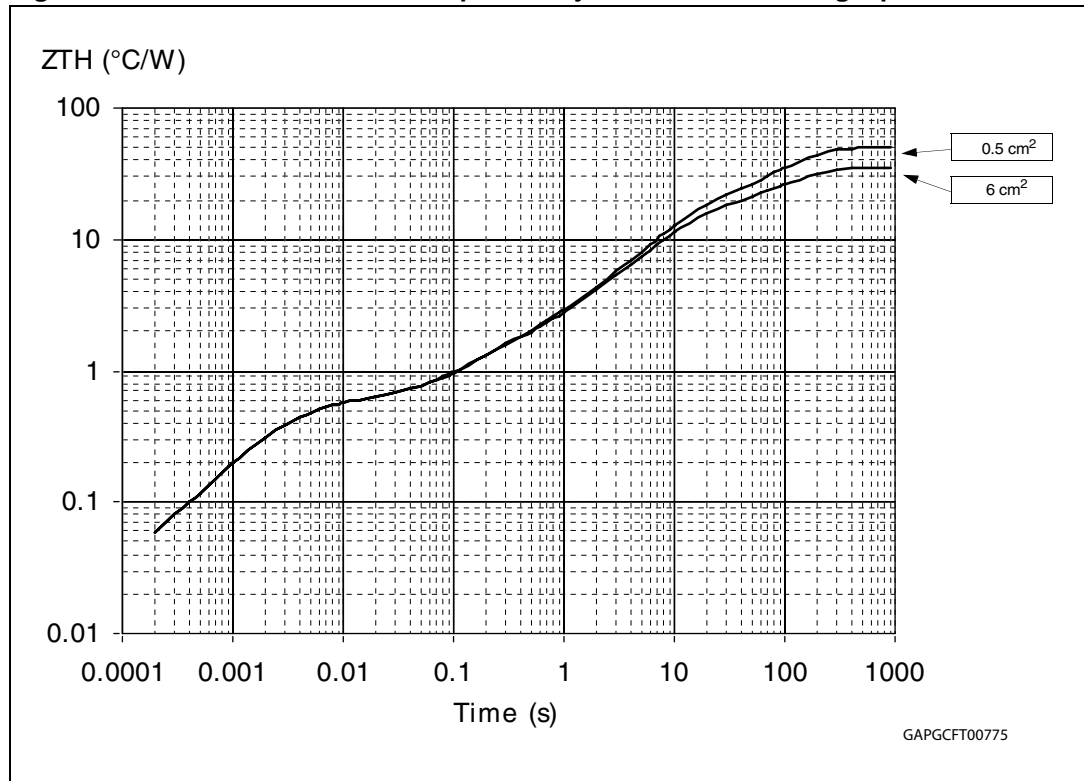

Figure 37. PowerSO-10 thermal impedance junction ambient single pulse



Equation 3: pulse calculation formula

$$Z_{TH\delta} = R_{TH} \cdot \delta + Z_{THtp}(1 - \delta)$$

where  $\delta = t_p/T$

Figure 38. Thermal fitting model of a single channel HSD in PowerSO-10

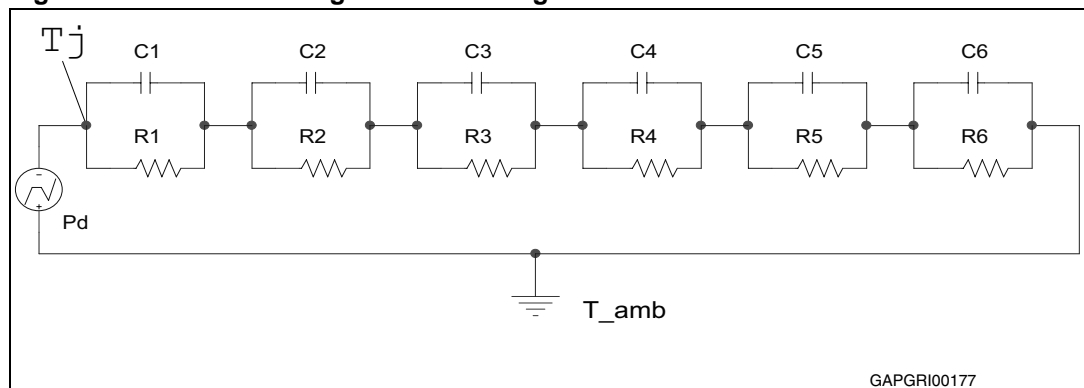

Table 16. PowerSO-10 thermal parameters

Area / island (cm <sup>2</sup> )	Footprint	6
R1 (°C/W)	0.04	
R2 (°C/W)	0.25	
R3 (°C/W)	0.25	
R4 (°C/W)	0.8	
R5 (°C/W)	12	
R6 (°C/W)	37	22
C1 (W.s/°C)	0.0008	
C2 (W.s/°C)	7E-03	
C3 (W.s/°C)	0.015	
C4 (W.s/°C)	0.3	
C5 (W.s/°C)	0.75	
C6 (W.s/°C)	3	5

## 5 Package and packing information

### 5.1 ECOPACK<sup>®</sup> packages

In order to meet environmental requirements, ST offers these devices in different grades of ECOPACK<sup>®</sup> packages, depending on their level of environmental compliance. ECOPACK<sup>®</sup> specifications, grade definitions and product status are available at: [www.st.com](http://www.st.com). ECOPACK<sup>®</sup> is an ST trademark.

### 5.2 PENTAWATT mechanical data

Figure 39. PENTAWATT package dimensions

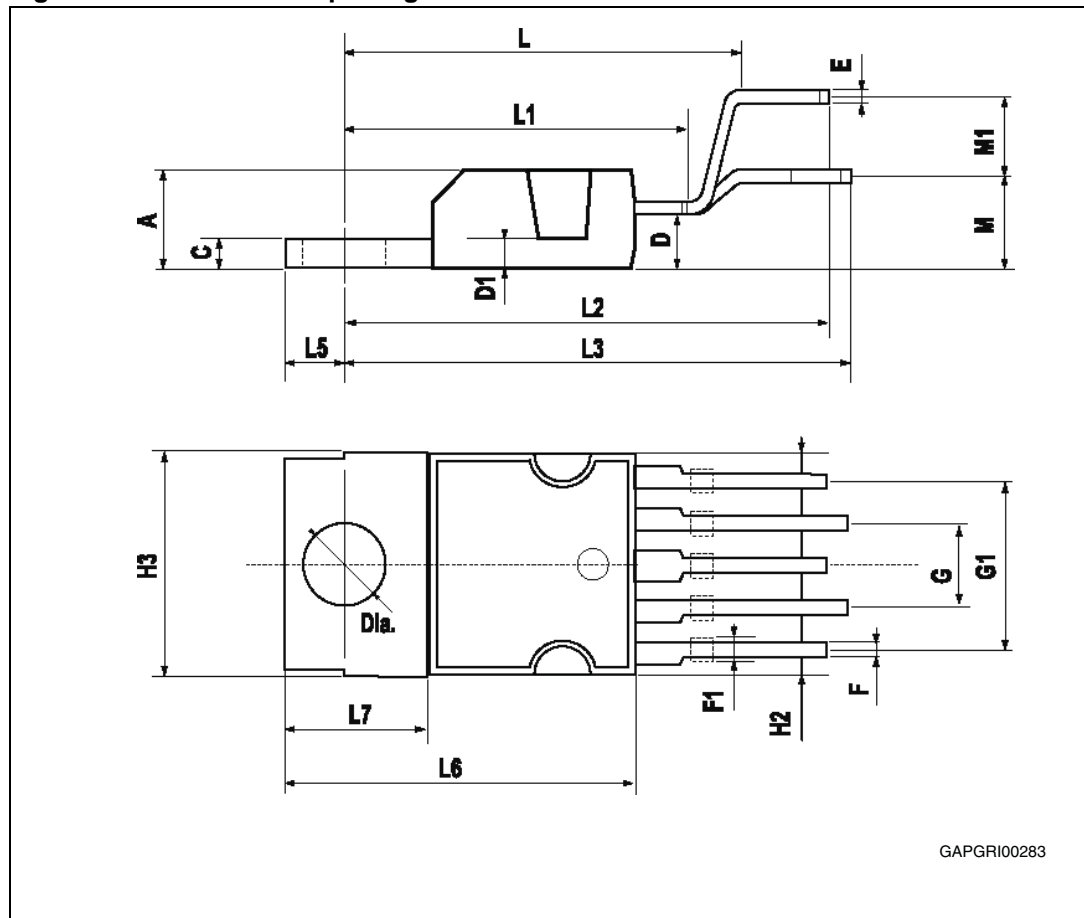

GAPGRI00283

Table 17. PENTAWATT mechanical data

Dim.	mm		
	Min.	Typ.	Max.
A			4.8
C			1.37
D	2.4		2.8
D1	1.2		1.35
E	0.35		0.55
F	0.8		1.05
F1	1		1.4
G	3.2	3.4	3.6
G1	6.6	6.8	7
H2			10.4
H3	10.05		10.4
L		17.85	
L1		15.75	
L2		21.4	
L3		22.5	
L5	2.6		3
L6	15.1		15.8
L7	6		6.6
M		4.5	
M1		4	
Diam.	3.65		3.85

### 5.3 P<sup>2</sup>PAK mechanical data

Figure 40. P<sup>2</sup>PAK package dimensions

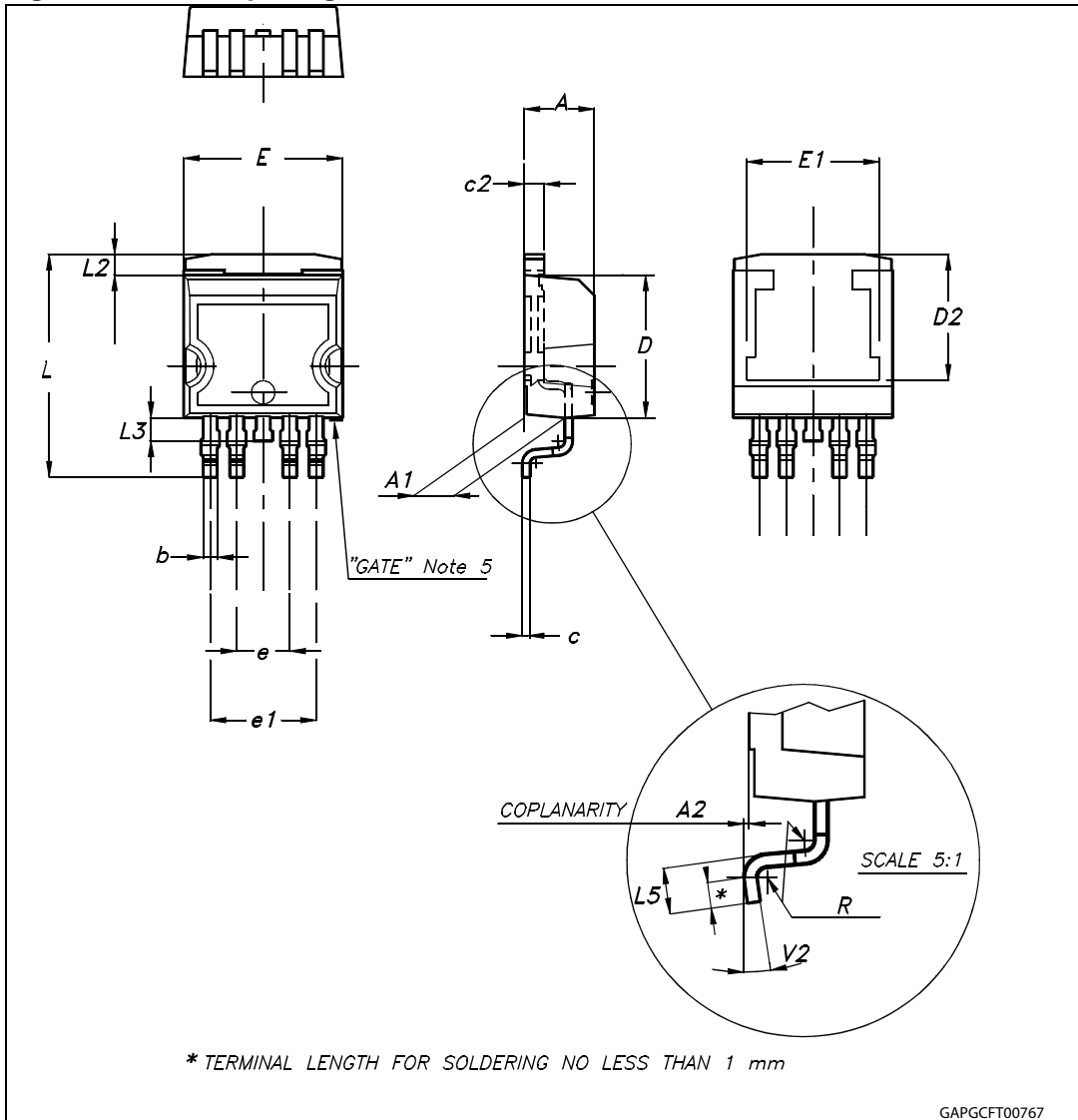
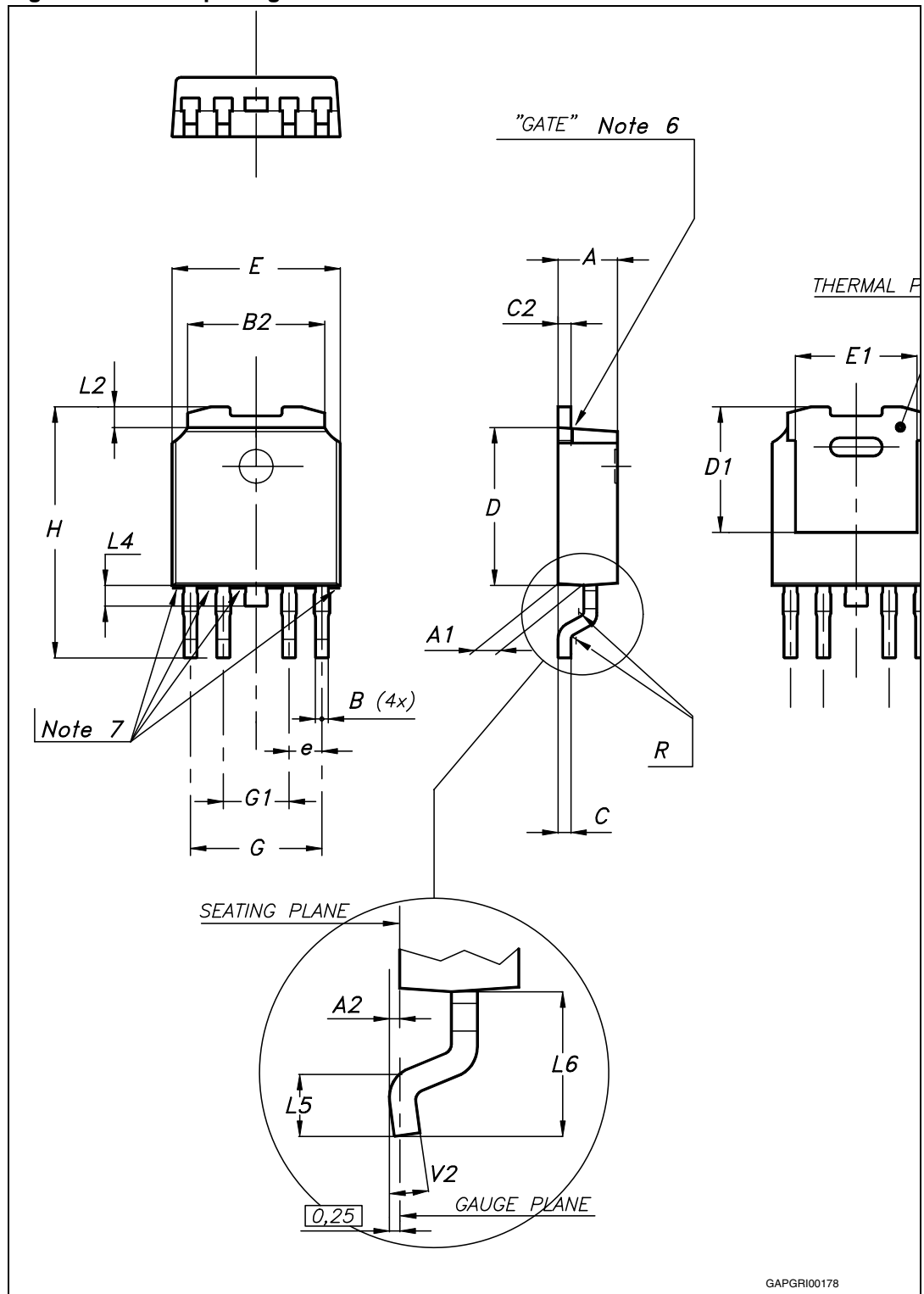

Table 18. P<sup>2</sup>PAK mechanical data

Dim.	mm		
	Min.	Typ.	Max.
A	4.30		4.80
A1	2.40		2.80
A2	0.03		0.23
b	0.80		1.05
c	0.45		0.60
c2	1.17		1.37
D	8.95		9.35
D2		8.00	
E	10.00		10.40
E1		8.50	
e	3.20		3.60
e1	6.60		7.00
L	13.70		14.50
L2	1.25		1.40
L3	0.90		1.70
L5	1.55		2.40
R		0.40	
V2	0°		8°
Package weight	1.40 Gr (typ)		

### 5.4 PPAK mechanical data

Figure 41. PPAK package dimensions



GAPGRI00178

Table 19. PPAK mechanical data

Dim.	mm		
	Min.	Typ.	Max.
A	2.20		2.40
A1	0.90		1.10
A2	0.03		0.23
B	0.40		0.60
B2	5.20		5.40
C	0.45		0.60
C2	0.48		0.60
D1		5.1	
D	6.00		6.20
E	6.40		6.60
E1		4.7	
e		1.27	
G	4.90		5.25
G1	2.38		2.70
H	9.35		10.10
L2		0.8	1.00
L4	0.60		1.00
L5	1		
L6		2.80	
R		0.2	
V2	0°		8°
Package weight	Gr. 0.3		

### 5.5 PowerSO-10 mechanical data

Figure 42. PowerSO-10 package dimensions

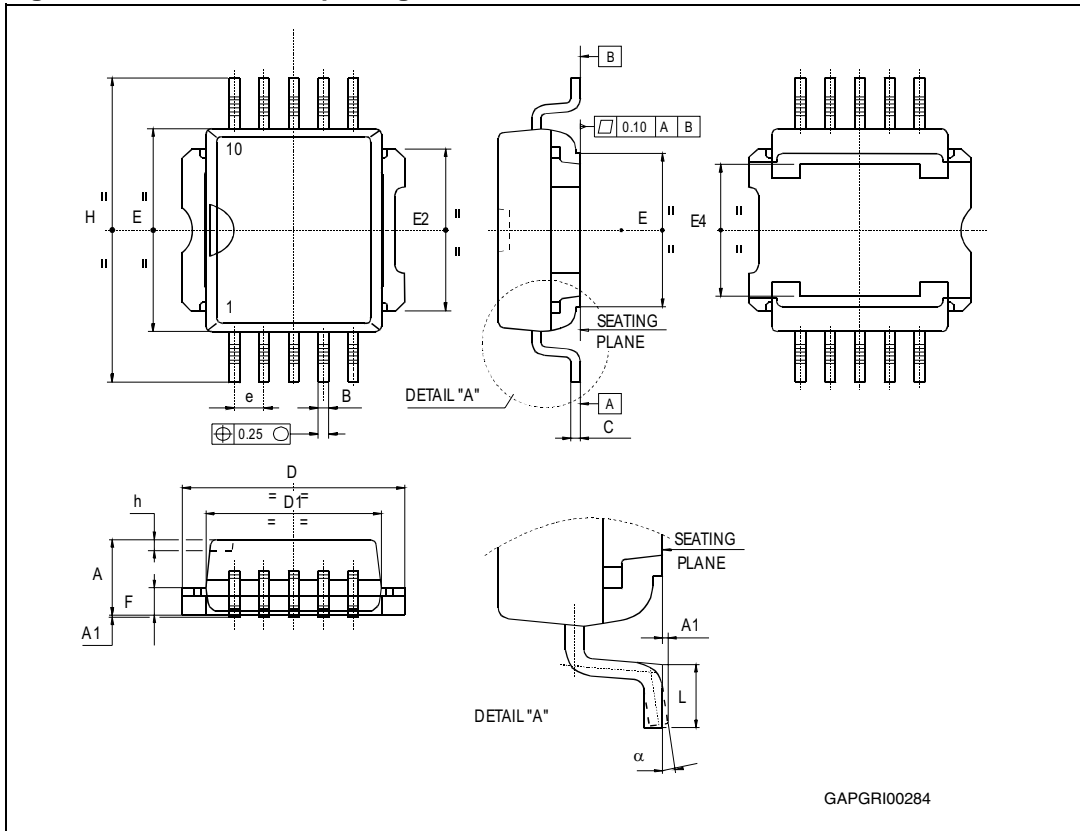

Table 20. PowerSO-10 mechanical data

Dim.	mm		
	Min.	Typ.	Max.
A	3.35		3.65
A <sup>(1)</sup>	3.4		3.6
A1	0		0.10
B	0.40		0.60
B <sup>(1)</sup>	0.37		0.53
C	0.35		0.55
C <sup>(1)</sup>	0.23		0.32
D	9.40		9.60
D1	7.40		7.60
E	9.30		9.50
E2	7.20		7.60
E2 <sup>(1)</sup>	7.30		7.50
E4	5.90		6.10
E4 <sup>(1)</sup>	5.90		6.30
e		1.27	
F	1.25		1.35
F <sup>(1)</sup>	1.20		1.40
H	13.80		14.40
H <sup>(1)</sup>	13.85		14.35
h		0.50	
L	1.20		1.80
L <sup>(1)</sup>	0.80		1.10
$\alpha$	0°		8°
$\alpha$ <sup>(1)</sup>	2°		8°

1. Muar only POA P013P.

### 5.6 PENTAWATT packing information

Figure 43. PENTAWATT tube shipment (no suffix)

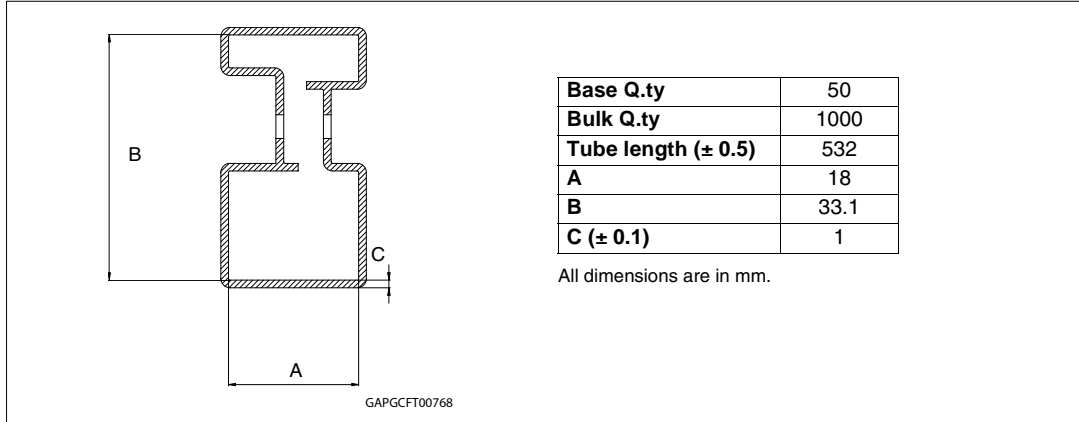

### 5.7 P<sup>2</sup>PAK packing information

Figure 44. P<sup>2</sup>PAK tube shipment (no suffix)

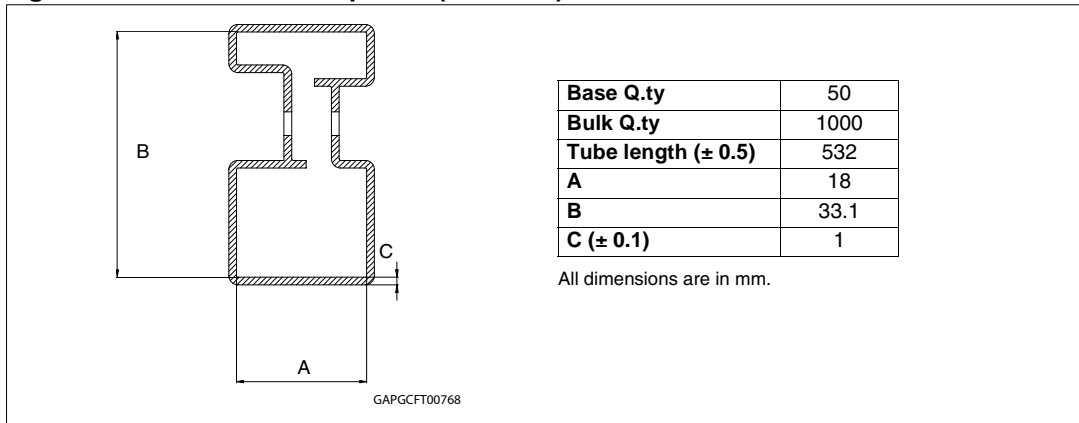
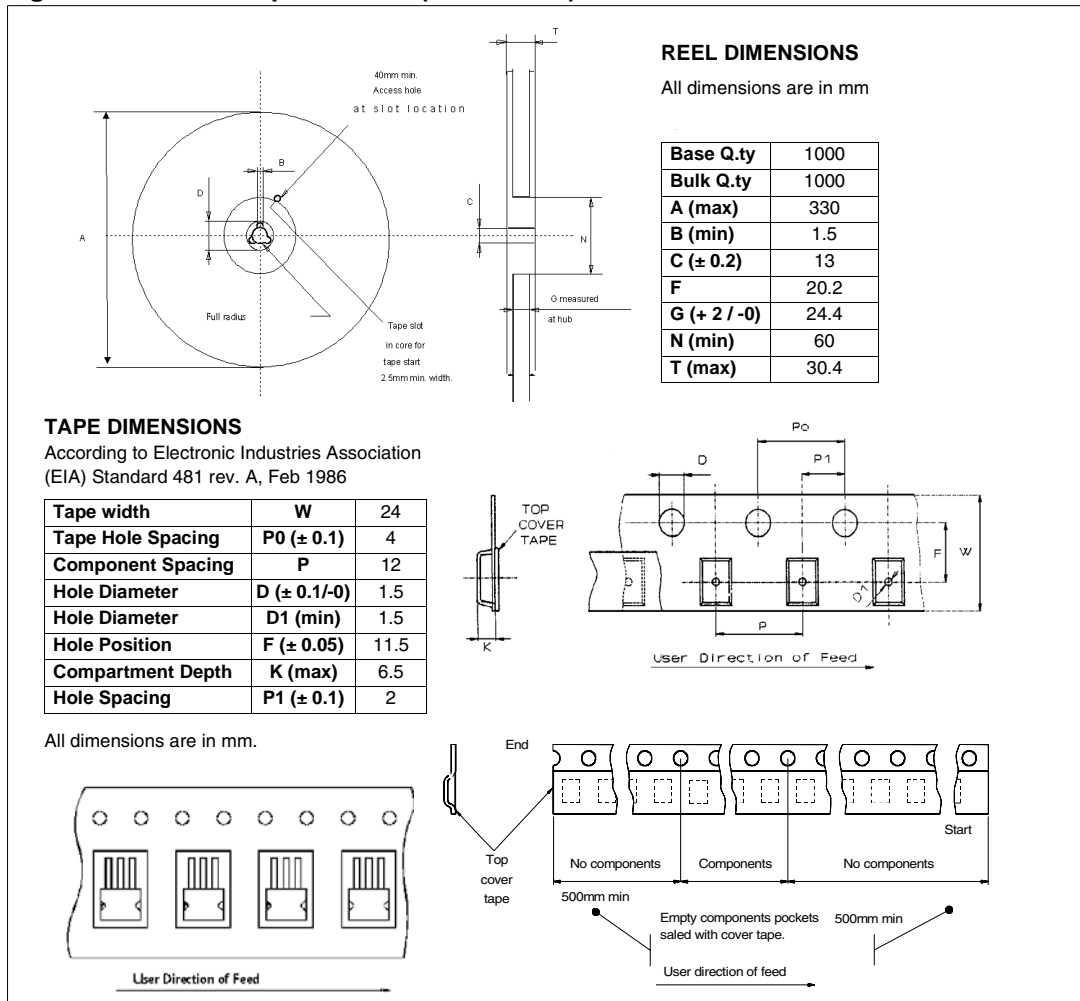

Figure 45. P<sup>2</sup>PAK tape and reel (suffix “TR”)



### 5.8 PPAK packing information

Figure 46. PPAK suggested pad layout

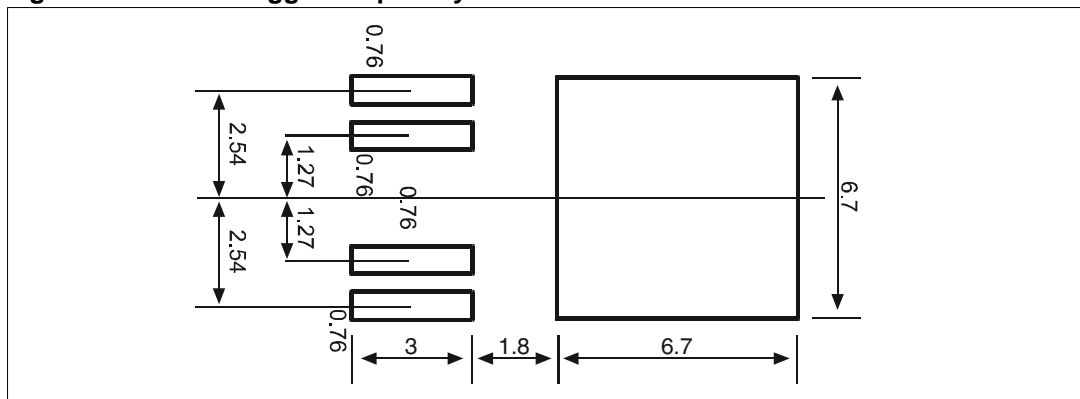

Figure 47. PPAK tube shipment (no suffix)

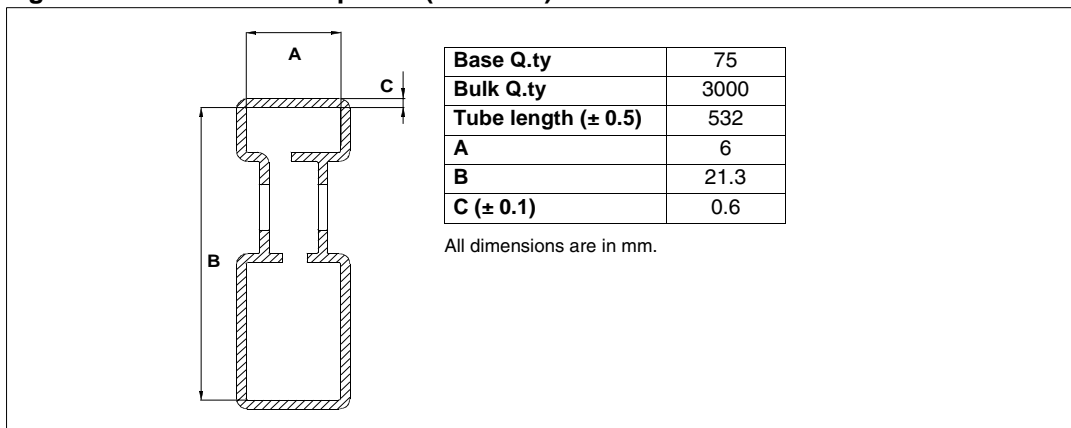
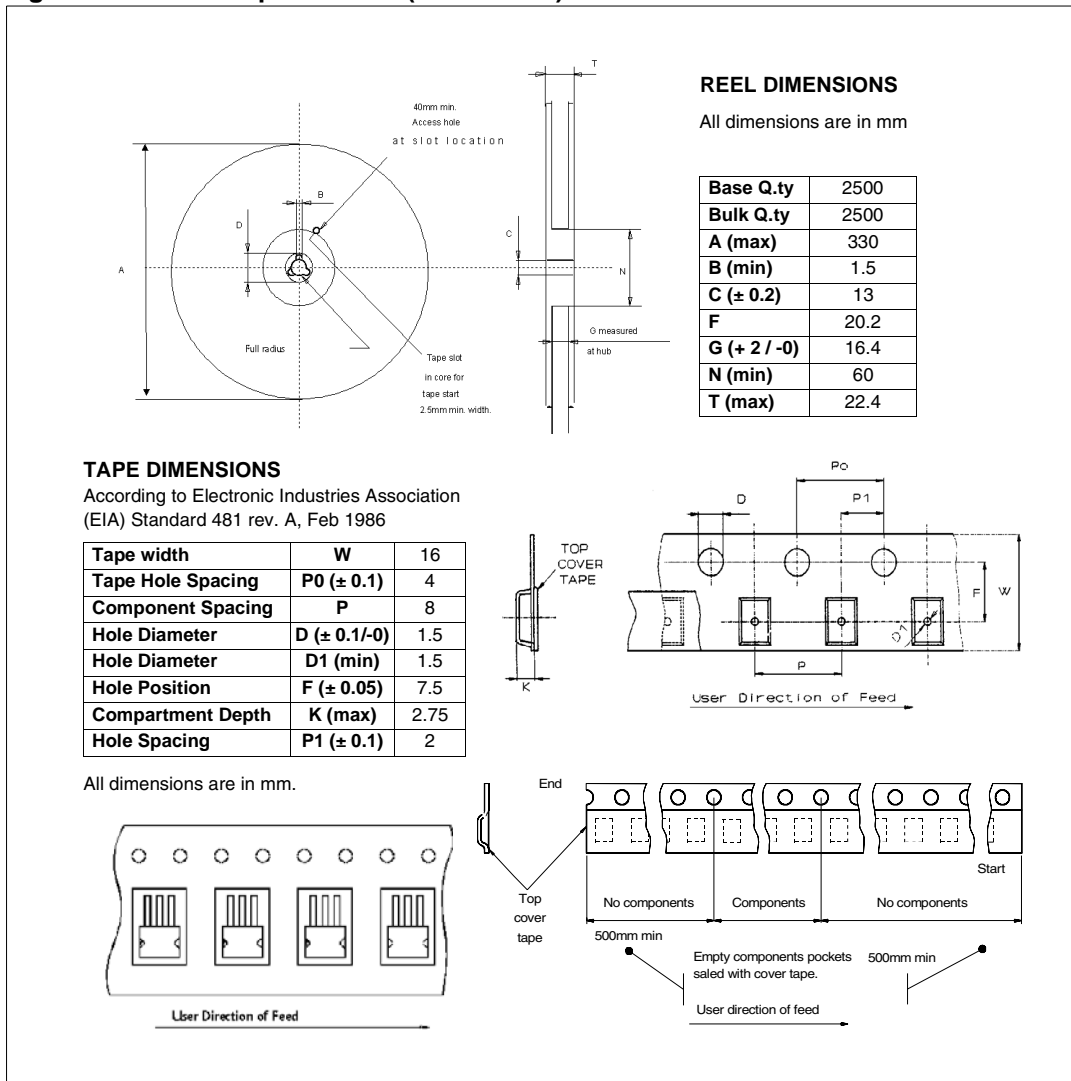

Figure 48. PPAK tape and reel (suffix "TR")



### 5.9 PowerSO-10 packing information

Figure 49. PowerSO-10 suggested pad layout      Figure 50. PowerSO-10 tube shipment (no pad layout)

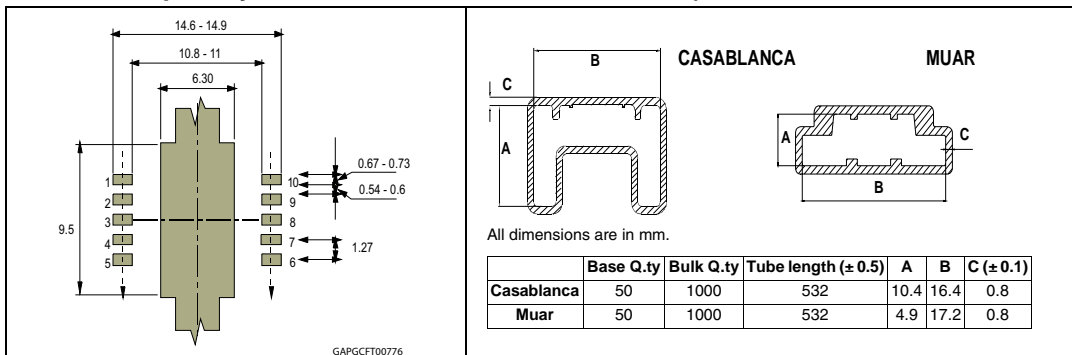
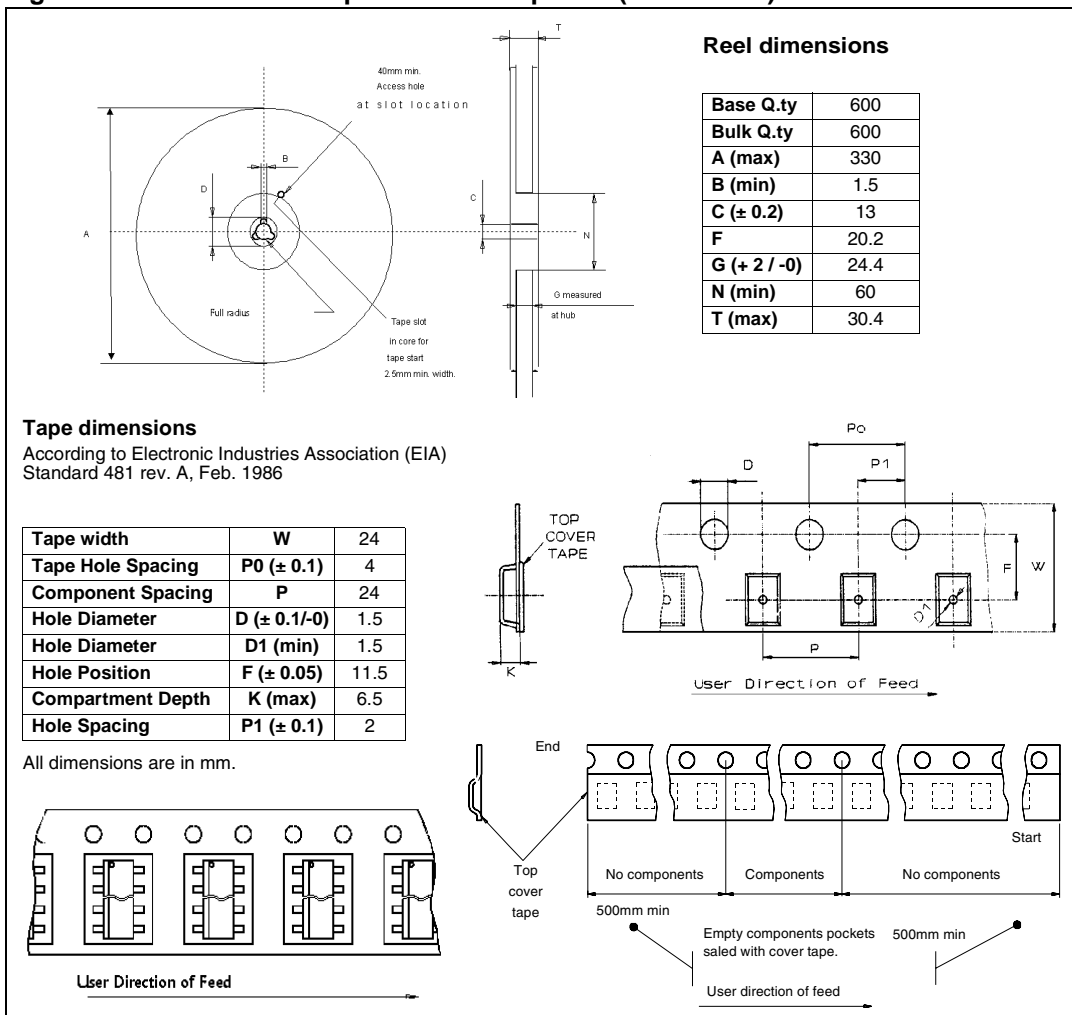

Figure 51. PowerSO-10 tape and reel shipment (suffix “TR”)



## 6 Revision history

**Table 21. Document revision history**

Date	Revision	Changes
07-Dec-2004	1	Initial release.
09-Feb-2005	2	Text changed.
23-Mar-2005	3	Configuration diagram (PowerSO-10) modification.
03-May-2006	4	SO-16L mechanical and shipment data insertion.
17-Dec-2008	5	Document reformatted and restructured. Added content, list of figures and tables. Added <i>ECOPACK® packages</i> information. Updated <i>Figure 45: P2PAK tape and reel (suffix "TR")</i> : – changed component spacing (P) in tape dimensions table from 16 mm to 12 mm.
29-Mar-2010	6	Updated features list. Updated <i>Table 1: Device summary</i> . Updated <i>Table 3: Absolute maximum ratings</i> . Updated <i>Section 3.5: PowerSO-10, P2PAK, PPAK, PENTAWATT maximum demagnetization energy (VCC = 13.5V)</i> . Removed SO-16L package into the document.
07-June-2012	7	Updated <i>Section 5.8: PPAK packing information</i> .
24-Sep-2013	8	Updated Disclaimer.

**Please Read Carefully:**

Information in this document is provided solely in connection with ST products. STMicroelectronics NV and its subsidiaries ("ST") reserve the right to make changes, corrections, modifications or improvements, to this document, and the products and services described herein at any time, without notice.

All ST products are sold pursuant to ST's terms and conditions of sale.

Purchasers are solely responsible for the choice, selection and use of the ST products and services described herein, and ST assumes no liability whatsoever relating to the choice, selection or use of the ST products and services described herein.

No license, express or implied, by estoppel or otherwise, to any intellectual property rights is granted under this document. If any part of this document refers to any third party products or services it shall not be deemed a license grant by ST for the use of such third party products or services, or any intellectual property contained therein or considered as a warranty covering the use in any manner whatsoever of such third party products or services or any intellectual property contained therein.

**UNLESS OTHERWISE SET FORTH IN ST'S TERMS AND CONDITIONS OF SALE ST DISCLAIMS ANY EXPRESS OR IMPLIED WARRANTY WITH RESPECT TO THE USE AND/OR SALE OF ST PRODUCTS INCLUDING WITHOUT LIMITATION IMPLIED WARRANTIES OF MERCHANTABILITY, FITNESS FOR A PARTICULAR PURPOSE (AND THEIR EQUIVALENTS UNDER THE LAWS OF ANY JURISDICTION), OR INFRINGEMENT OF ANY PATENT, COPYRIGHT OR OTHER INTELLECTUAL PROPERTY RIGHT.**

**ST PRODUCTS ARE NOT DESIGNED OR AUTHORIZED FOR USE IN: (A) SAFETY CRITICAL APPLICATIONS SUCH AS LIFE SUPPORTING, ACTIVE IMPLANTED DEVICES OR SYSTEMS WITH PRODUCT FUNCTIONAL SAFETY REQUIREMENTS; (B) AERONAUTIC APPLICATIONS; (C) AUTOMOTIVE APPLICATIONS OR ENVIRONMENTS, AND/OR (D) AEROSPACE APPLICATIONS OR ENVIRONMENTS. WHERE ST PRODUCTS ARE NOT DESIGNED FOR SUCH USE, THE PURCHASER SHALL USE PRODUCTS AT PURCHASER'S SOLE RISK, EVEN IF ST HAS BEEN INFORMED IN WRITING OF SUCH USAGE, UNLESS A PRODUCT IS EXPRESSLY DESIGNATED BY ST AS BEING INTENDED FOR "AUTOMOTIVE, AUTOMOTIVE SAFETY OR MEDICAL" INDUSTRY DOMAINS ACCORDING TO ST PRODUCT DESIGN SPECIFICATIONS. PRODUCTS FORMALLY ESCC, QML OR JAN QUALIFIED ARE DEEMED SUITABLE FOR USE IN AEROSPACE BY THE CORRESPONDING GOVERNMENTAL AGENCY.**

Resale of ST products with provisions different from the statements and/or technical features set forth in this document shall immediately void any warranty granted by ST for the ST product or service described herein and shall not create or extend in any manner whatsoever, any liability of ST.

ST and the ST logo are trademarks or registered trademarks of ST in various countries.

Information in this document supersedes and replaces all information previously supplied.

The ST logo is a registered trademark of STMicroelectronics. All other names are the property of their respective owners.

© 2013 STMicroelectronics - All rights reserved



STMicroelectronics group of companies

Australia - Belgium - Brazil - Canada - China - Czech Republic - Finland - France - Germany - Hong Kong - India - Israel - Italy - Japan - Malaysia - Malta - Morocco - Philippines - Singapore - Spain - Sweden - Switzerland - United Kingdom - United States of America





[www.st.com](http://www.st.com)

## Looking for pricing, stock, or lifecycle information?

Click below to explore more details on WIN SOURCE:

-  [View VN820SP-E on WIN SOURCE](#)
-  [STMicroelectronics](#) Information

## Optimize Your Supply Chain with WIN SOURCE Solutions

-  Global Sourcing Solution
-  Obsolete Management
-  Cost Control Management
-  Shortage Management
-  Alternative Solution
-  Excess Inventory Management