

SN54ALS569A, SN74ALS568A, SN74ALS569A SYNCHRONOUS 4-BIT UP/DOWN DECADE AND BINARY COUNTERS WITH 3-STATE OUTPUTS

SDAS229A – APRIL 1982 – REVISED JANUARY 1995

- 3-State Q Outputs Drive Bus Lines Directly
- Counter Operation Independent of 3-State Output
- Fully Synchronous Clear, Count, and Load
- Asynchronous Clear Is Also Provided
- Fully Cascadable
- Package Options Include Plastic Small-Outline (DW) Packages, Ceramic Chip Carriers (FK), and Standard Plastic (N) and Ceramic (J) 300-mil DIPs

description

The SN74ALS568A decade counter and 'ALS569A binary counters are programmable, count up or down, and offer both synchronous and asynchronous clearing. All synchronous functions are executed on the positive-going edge of the clock (CLK) input.

The clear function is initiated by applying a low level to either asynchronous clear ($\overline{\text{ACLR}}$) or synchronous clear ($\overline{\text{SCLR}}$). Asynchronous (direct) clearing overrides all other functions of the device, while synchronous clearing overrides only the other synchronous functions. Data is loaded from the A, B, C, and D inputs by holding load ($\overline{\text{LOAD}}$) low during a positive-going clock transition. The counting function is enabled only when enable P ($\overline{\text{ENP}}$) and enable T ($\overline{\text{ENT}}$) are low and $\overline{\text{ACLR}}$, $\overline{\text{SCLR}}$, and $\overline{\text{LOAD}}$ are high. The up/down ($\overline{\text{U/D}}$) input controls the direction of the count. These counters count up when $\overline{\text{U/D}}$ is high and count down when $\overline{\text{U/D}}$ is low.

A high level at the output-enable ($\overline{\text{OE}}$) input forces the Q outputs into the high-impedance state, and a low level enables those outputs. Counting is independent of $\overline{\text{OE}}$. $\overline{\text{ENT}}$ is fed forward to enable the ripple-carry output ($\overline{\text{RCO}}$) to produce a low-level pulse while the count is zero (all Q outputs low) when counting down or maximum (9 or 15) when counting up. The clocked carry output ($\overline{\text{CCO}}$) produces a low-level pulse for a duration equal to that of the low level of the clock when $\overline{\text{RCO}}$ is low and the counter is enabled (both $\overline{\text{ENP}}$ and $\overline{\text{ENT}}$ are low); otherwise, $\overline{\text{CCO}}$ is high. $\overline{\text{CCO}}$ does not have the glitches commonly associated with a ripple-carry output. Cascading is normally accomplished by connecting $\overline{\text{RCO}}$ or $\overline{\text{CCO}}$ of the first counter to $\overline{\text{ENT}}$ of the next counter. However, for very high-speed counting, $\overline{\text{RCO}}$ should be used for cascading since $\overline{\text{CCO}}$ does not become active until the clock returns to the low level.

The SN54ALS569A is characterized for operation over the full military temperature range of -55°C to 125°C . The SN74ALS568A and SN74ALS569A are characterized for operation from 0°C to 70°C .

SN54ALS569A . . . J PACKAGE
SN74ALS568A, SN74ALS569A . . . DW OR N PACKAGE
(TOP VIEW)

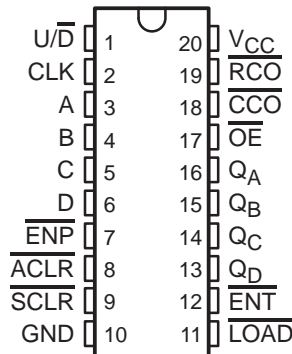

SN54ALS569A . . . FK PACKAGE
(TOP VIEW)

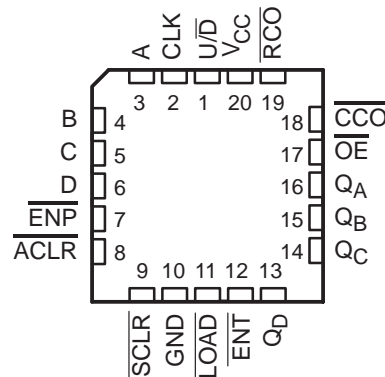

SN54ALS569A, SN74ALS568A, SN74ALS569A
SYNCHRONOUS 4-BIT UP/DOWN DECADE AND BINARY COUNTERS
WITH 3-STATE OUTPUTS

SDAS229A – APRIL 1982 – REVISED JANUARY 1995

FUNCTION TABLE

INPUTS								OPERATION
\overline{OE}	\overline{ACLR}	\overline{SCLR}	\overline{LOAD}	\overline{ENT}	\overline{ENP}	U/D	CLK	
H	X	X	X	X	X	X	X	Q outputs disabled
L	L	X	X	X	X	X	X	Asynchronous clear
L	H	L	X	X	X	X	↑	Synchronous clear
L	H	H	L	X	X	X	↑	Load
L	H	H	H	L	L	H	↑	Count up
L	H	H	H	L	L	L	↑	Count down
L	H	H	H	H	X	X	X	Inhibit count
L	H	H	H	X	H	X	X	Inhibit count

SN54ALS569A, SN74ALS568A, SN74ALS569A SYNCHRONOUS 4-BIT UP/DOWN DECADE AND BINARY COUNTERS WITH 3-STATE OUTPUTS

SDAS229A – APRIL 1982 – REVISED JANUARY 1995

logic symbols†

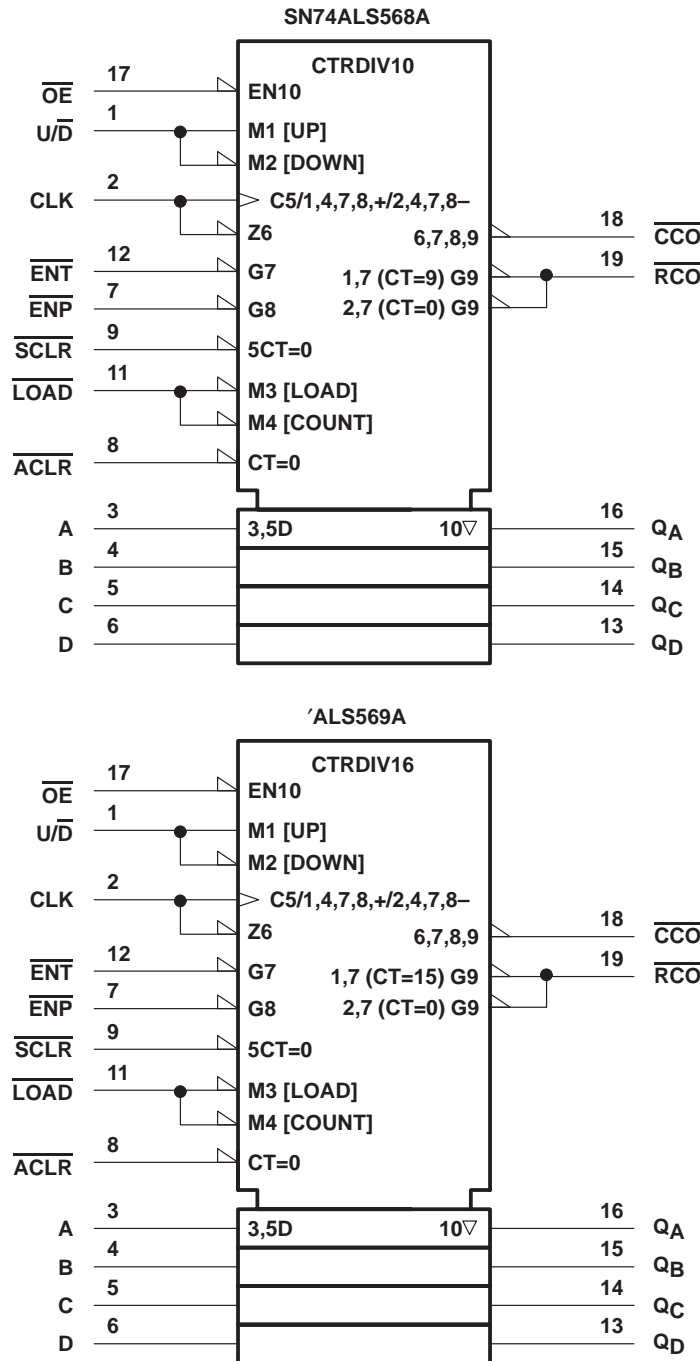

† These symbols are in accordance with ANSI/IEEE Std 91-1984 and IEC Publication 617-12.

SN54ALS569A, SN74ALS568A, SN74ALS569A SYNCHRONOUS 4-BIT UP/DOWN DECADE AND BINARY COUNTERS WITH 3-STATE OUTPUTS

SDAS229A – APRIL 1982 – REVISED JANUARY 1995

logic diagrams (positive logic)

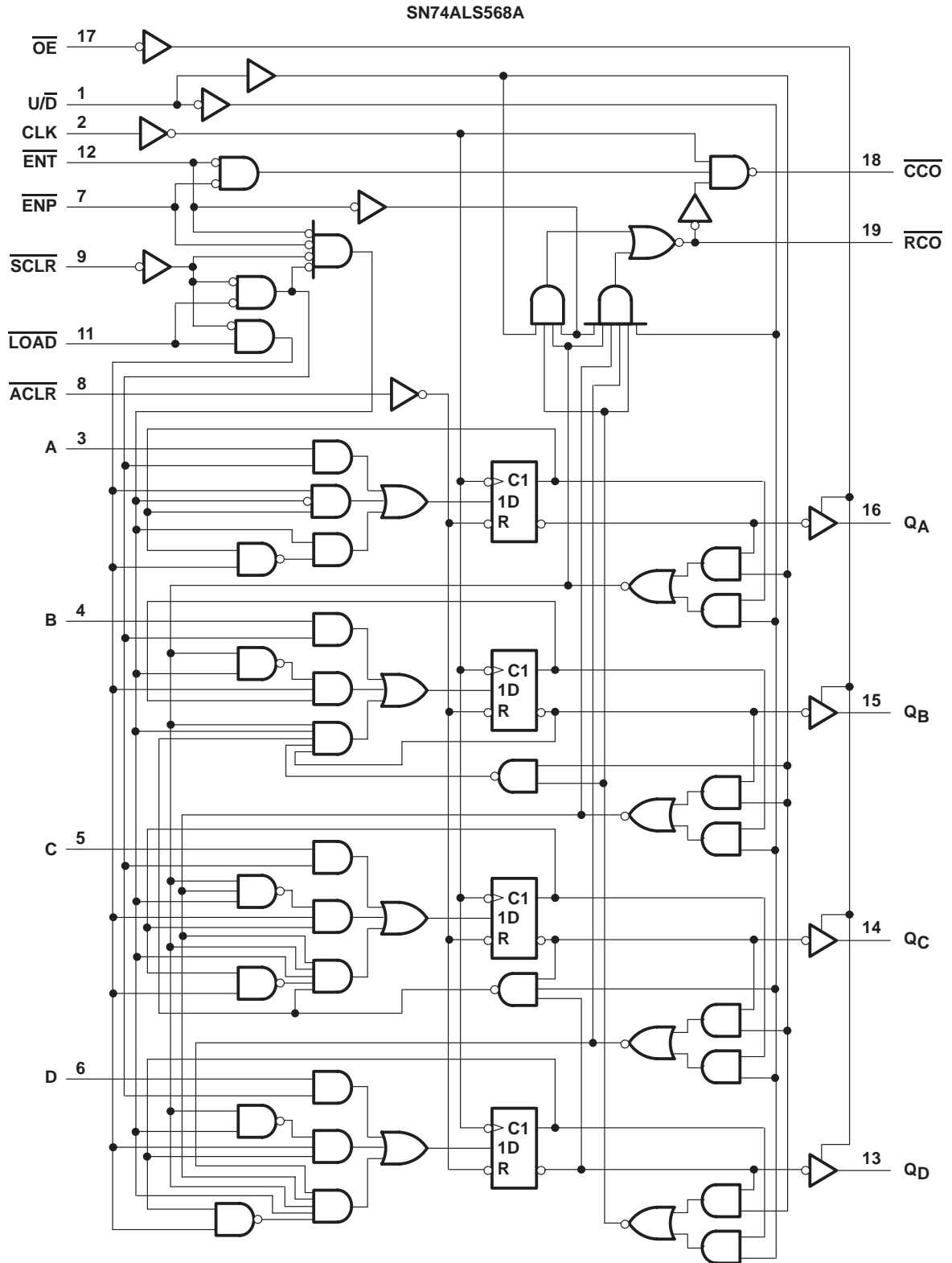

SN54ALS569A, SN74ALS568A, SN74ALS569A SYNCHRONOUS 4-BIT UP/DOWN DECADE AND BINARY COUNTERS WITH 3-STATE OUTPUTS

SDAS229A – APRIL 1982 – REVISED JANUARY 1995

logic diagrams (positive logic) (continued)

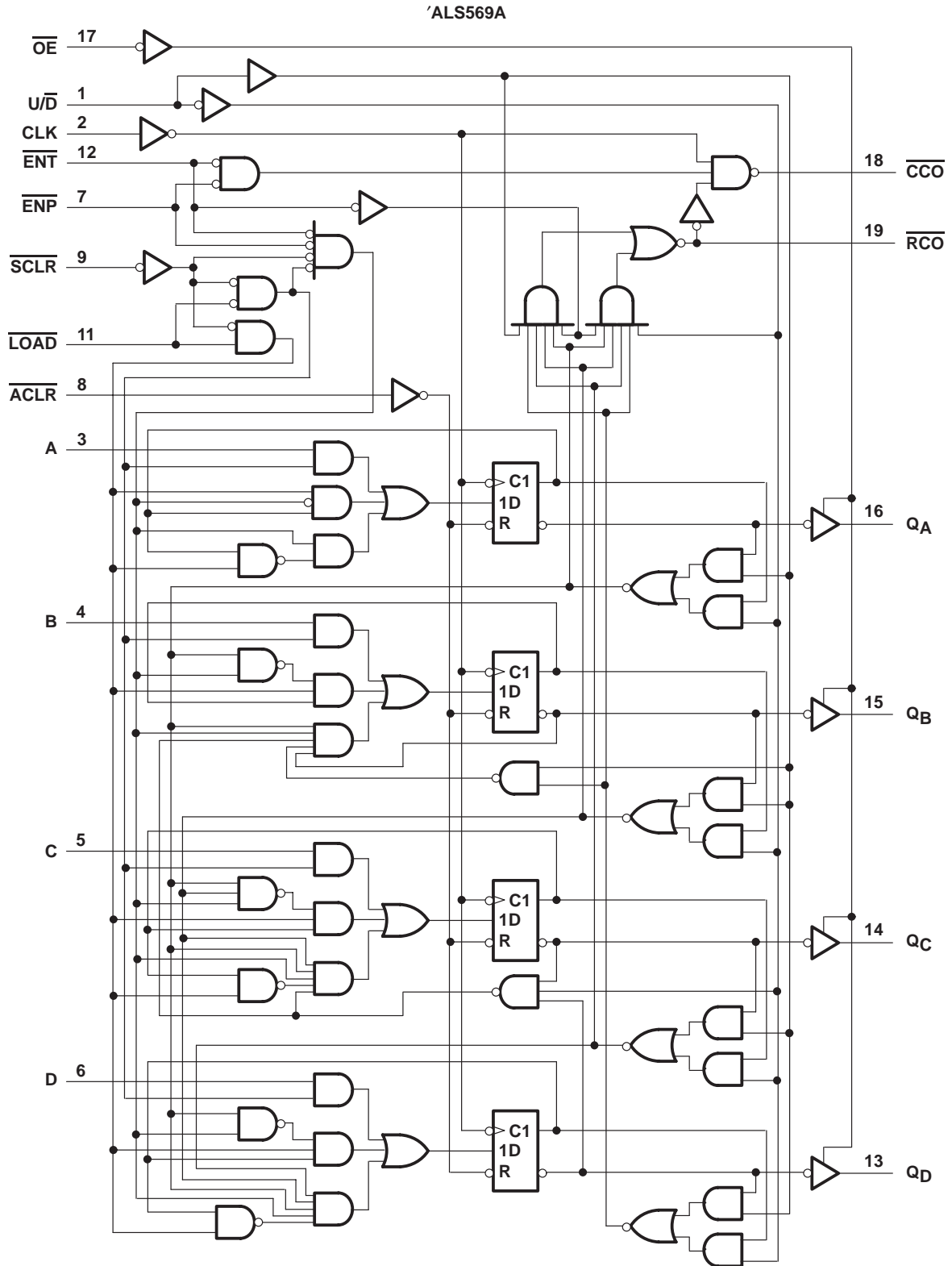

SN54ALS569A, SN74ALS568A, SN74ALS569A SYNCHRONOUS 4-BIT UP/DOWN DECADE AND BINARY COUNTERS WITH 3-STATE OUTPUTS

SDAS229A – APRIL 1982 – REVISED JANUARY 1995

typical load, count, and inhibit sequences

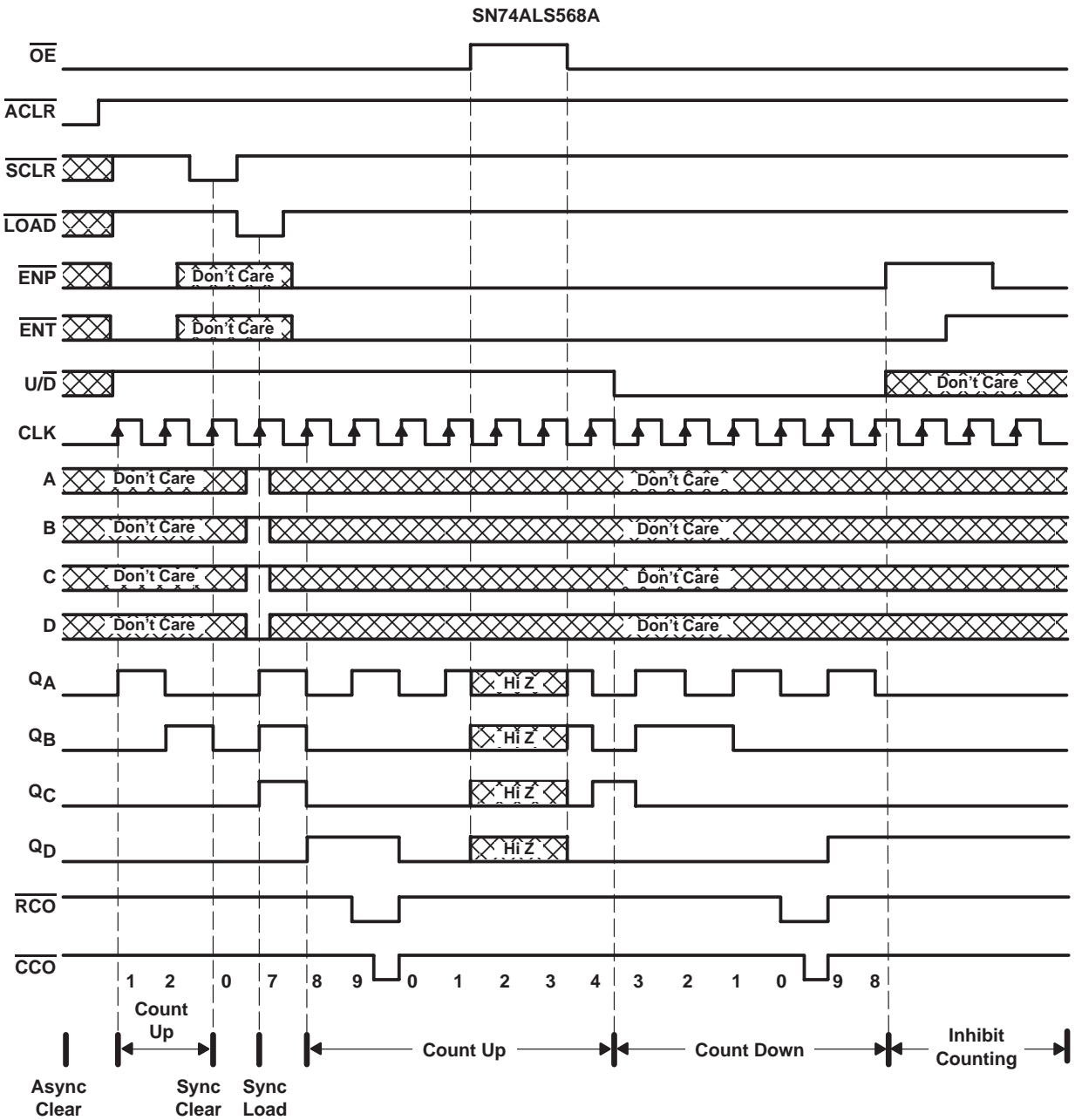

SN54ALS569A, SN74ALS568A, SN74ALS569A SYNCHRONOUS 4-BIT UP/DOWN DECADE AND BINARY COUNTERS WITH 3-STATE OUTPUTS

SDAS229A – APRIL 1982 – REVISED JANUARY 1995

typical load, count, and inhibit sequences (continued)

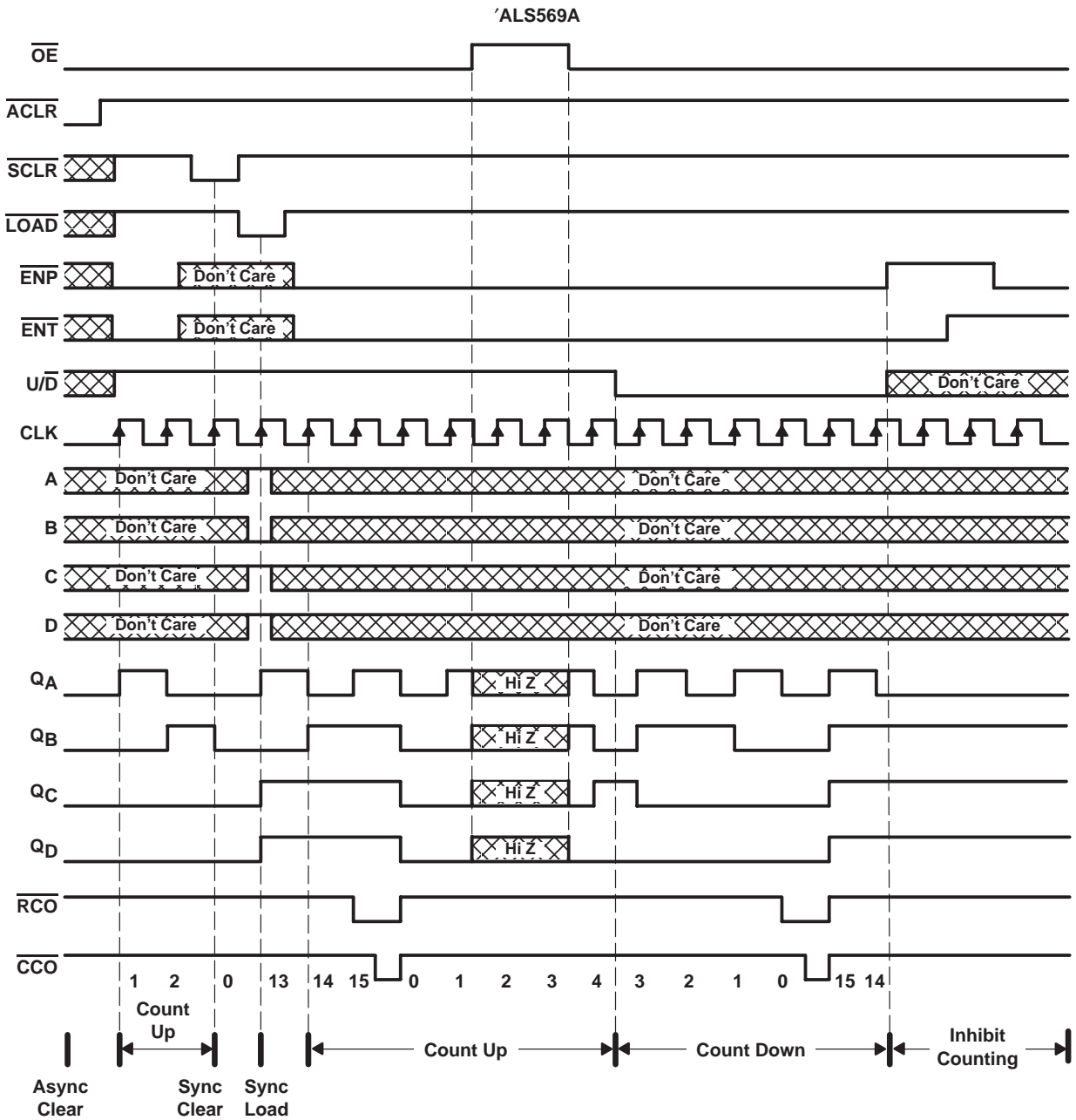

SN54ALS569A, SN74ALS568A, SN74ALS569A SYNCHRONOUS 4-BIT UP/DOWN DECADE AND BINARY COUNTERS WITH 3-STATE OUTPUTS

SDAS229A – APRIL 1982 – REVISED JANUARY 1995

absolute maximum ratings over operating free-air temperature range (unless otherwise noted)†

Supply voltage, V_{CC}	7 V
Input voltage, V_I	7 V
Voltage applied to a disabled 3-state output	5.5 V
Operating free-air temperature range, T_A : SN54ALS569A	-55°C to 125°C
SN74ALS568A, SN74ALS569A	0°C to 70°C
Storage temperature range	-65°C to 150°C

† Stresses beyond those listed under “absolute maximum ratings” may cause permanent damage to the device. These are stress ratings only, and functional operation of the device at these or any other conditions beyond those indicated under “recommended operating conditions” is not implied. Exposure to absolute-maximum-rated conditions for extended periods may affect device reliability.

recommended operating conditions

		SN54ALS569A			SN74ALS568A SN74ALS569A			UNIT		
		MIN	NOM	MAX	MIN	NOM	MAX			
V_{CC}	Supply voltage	4.5	5	5.5	4.5	5	5.5	V		
V_{IH}	High-level input voltage	2			2			V		
V_{IL}	Low-level input voltage			0.7			0.8	V		
I_{OH}	High-level output current	Q outputs		-1			-2.6	mA		
		\overline{CCO} and \overline{RCO}				-0.4	-0.4			
I_{OL}	Low-level output current	Q outputs				12	24	mA		
		\overline{CCO} and \overline{RCO}				4	8			
f_{clock}	Clock frequency	SN74ALS568A				0	20	MHz		
		'ALS569A				0	30			
t_w	Pulse duration	\overline{ACLR} or \overline{LOAD} low				20	15	ns		
		SN74ALS568A	CLK high						25	
			CLK low						25	
		'ALS569A	CLK high				20		16.5	
CLK low					23	16.5				
t_{su}	Setup time before $CLK\uparrow$	Data at A, B, C, D				25	20	ns		
		\overline{ENP} , \overline{ENT}	High				35		30	
			Low				25		20	
		\overline{SCLR}	Low				20		15	
			High (inactive)				35		30	
		\overline{LOAD}	Low				20		15	
			High (inactive)				35		30	
$\overline{U/D}$						35	30			
\overline{ACLR} inactive						10	10			
t_h	Hold time after $CLK\uparrow$ for any input					0	0	ns		
T_A	Operating free-air temperature					-55	125	0	70	°C



SN54ALS569A, SN74ALS568A, SN74ALS569A SYNCHRONOUS 4-BIT UP/DOWN DECADE AND BINARY COUNTERS WITH 3-STATE OUTPUTS

SDAS229A – APRIL 1982 – REVISED JANUARY 1995

electrical characteristics over recommended operating free-air temperature range (unless otherwise noted)

PARAMETER		TEST CONDITIONS		SN54ALS569A			SN74ALS568A SN74ALS569A			UNIT
				MIN	TYP†	MAX	MIN	TYP†	MAX	
V_{IK}		$V_{CC} = 4.5\text{ V}$, $I_I = -18\text{ mA}$		-1.5			-1.5			V
V_{OH}	All outputs	$V_{CC} = 4.5\text{ V to }5.5\text{ V}$, $I_{OH} = -0.4\text{ mA}$		$V_{CC} - 2$			$V_{CC} - 2$			V
	Q outputs	$V_{CC} = 4.5\text{ V}$		2.4 3.3			2.4 3.2			
V_{OL}	Q outputs	$V_{CC} = 4.5\text{ V}$		0.25 0.4			0.25 0.4			V
		$V_{CC} = 4.5\text{ V}$		0.35 0.5			0.35 0.5			
	$V_{CC} = 4.5\text{ V}$		0.25 0.4			0.25 0.4				
	$V_{CC} = 4.5\text{ V}$		0.35 0.5			0.35 0.5				
I_{OZH}		$V_{CC} = 5.5\text{ V}$, $V_O = 2.7\text{ V}$		20			20			μA
I_{OZL}		$V_{CC} = 5.5\text{ V}$, $V_O = 0.4\text{ V}$		-20			-20			μA
I_I		$V_{CC} = 5.5\text{ V}$, $V_I = 7\text{ V}$		0.1			0.1			mA
I_{IH}		$V_{CC} = 5.5\text{ V}$, $V_I = 2.7\text{ V}$		20			20			μA
I_{IL}		$V_{CC} = 5.5\text{ V}$, $V_I = 0.4\text{ V}$		-0.2			-0.2			mA
$I_{O\ddagger}$	\overline{CCO} and \overline{RCO}	$V_{CC} = 5.5\text{ V}$, $V_O = 2.25\text{ V}$		-15 -70			-15 -70			mA
	Q outputs	$V_{CC} = 5.5\text{ V}$, $V_O = 2.25\text{ V}$		-20 -112			-30 -112			
I_{CC}	$V_{CC} = 5.5\text{ V}$		Outputs high	16 26			16 26			mA
	$V_{CC} = 5.5\text{ V}$		Outputs low	20 32			20 32			
	$V_{CC} = 5.5\text{ V}$		Outputs disabled	20 32			20 32			

† All typical values are at $V_{CC} = 5\text{ V}$, $T_A = 25^\circ\text{C}$.

‡ The output conditions have been chosen to produce a current that closely approximates one half of the true short-circuit output current, I_{OS} .

SN54ALS569A, SN74ALS568A, SN74ALS569A SYNCHRONOUS 4-BIT UP/DOWN DECADE AND BINARY COUNTERS WITH 3-STATE OUTPUTS

SDAS229A – APRIL 1982 – REVISED JANUARY 1995

switching characteristics (see Figure 1)

PARAMETER	FROM (INPUT)	TO (OUTPUT)	V _{CC} = 4.5 V to 5.5 V, C _L = 50 pF, R ₁ = 500 Ω, R ₂ = 500 Ω, T _A = MIN to MAX†				UNIT
			SN54ALS569A		SN74ALS568A SN74ALS569A		
			MIN	MAX	MIN	MAX	
f _{max}	SN74ALS568A				20	MHz	
	'ALS569A		22	30			
t _{PLH}	CLK	Any Q	4	21	4	13	ns
t _{PHL}			7	19	7	16	
t _{PLH}	CLK	\overline{RCO}	12	37	12	28	ns
t _{PHL}			10	28	10	19	
t _{PLH}	CLK	\overline{CCO}	5	17	5	13	ns
t _{PHL}			6	30	6	25	
t _{PLH}	U/ \overline{D}	\overline{RCO}	9	31	9	23	ns
t _{PHL}			9	33	9	19	
t _{PLH}	\overline{ENT}	\overline{RCO}	6	21	6	15	ns
t _{PHL}			4	20	4	13	
t _{PLH}	\overline{ENT}	\overline{CCO}	5	18	5	13	ns
t _{PHL}			9	32	9	23	
t _{PLH}	\overline{ENP}	\overline{CCO}	4	18	4	12	ns
t _{PHL}			5	18	5	14	
t _{PHL}	\overline{ACLR}	Any Q	9	25	9	20	ns
t _{PZH}	\overline{OE}	Any Q	6	23	6	18	ns
t _{PZL}			6	29	6	24	
t _{PHZ}	\overline{OE}	Any Q	1	12	1	10	ns
t _{PLZ}			3	29	3	13	

† For conditions shown as MIN or MAX, use the appropriate value specified under recommended operating conditions.

SN54ALS569A, SN74ALS568A, SN74ALS569A SYNCHRONOUS 4-BIT UP/DOWN DECADE AND BINARY COUNTERS WITH 3-STATE OUTPUTS

SDAS229A – APRIL 1982 – REVISED JANUARY 1995

PARAMETER MEASUREMENT INFORMATION SERIES 54ALS/74ALS AND 54AS/74AS DEVICES

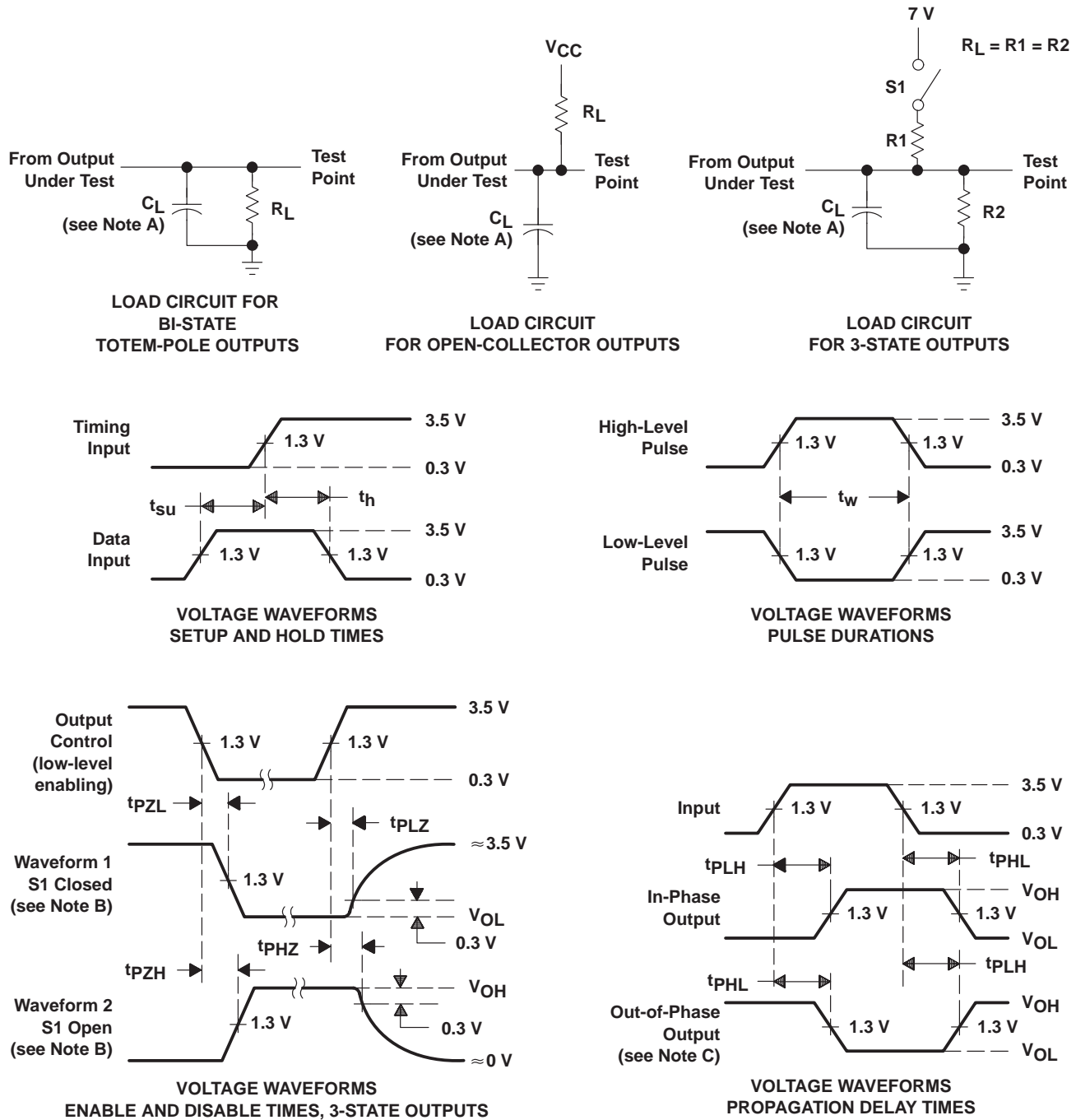

- NOTES: A. C_L includes probe and jig capacitance.
 B. Waveform 1 is for an output with internal conditions such that the output is low except when disabled by the output control. Waveform 2 is for an output with internal conditions such that the output is high except when disabled by the output control.
 C. When measuring propagation delay items of 3-state outputs, switch S1 is open.
 D. All input pulses have the following characteristics: $PRR \leq 1$ MHz, $t_r = t_f = 2$ ns, duty cycle = 50%.
 E. The outputs are measured one at a time with one transition per measurement.

Figure 1. Load Circuits and Voltage Waveforms

PACKAGING INFORMATION

Orderable Device	Status (1)	Package Type	Package Drawing	Pins	Package Qty	Eco Plan (2)	Lead finish/ Ball material (6)	MSL Peak Temp (3)	Op Temp (°C)	Device Marking (4/5)	Samples
83025022A	ACTIVE	LCCC	FK	20	55	Non-RoHS & Green	SNPB	N / A for Pkg Type	-55 to 125	83025022A SNJ54ALS 569AFK	Samples
8302502RA	ACTIVE	CDIP	J	20	20	Non-RoHS & Green	SNPB	N / A for Pkg Type	-55 to 125	8302502RA SNJ54ALS569AJ	Samples
SN54ALS569AJ	ACTIVE	CDIP	J	20	20	Non-RoHS & Green	SNPB	N / A for Pkg Type	-55 to 125	SN54ALS569AJ	Samples
SN74ALS569ADWR	ACTIVE	SOIC	DW	20	2000	RoHS & Green	NIPDAU	Level-1-260C-UNLIM	0 to 70	ALS569A	Samples
SN74ALS569AN	ACTIVE	PDIP	N	20	20	RoHS & Non-Green	NIPDAU	N / A for Pkg Type	0 to 70	SN74ALS569AN	Samples
SNJ54ALS569AFK	ACTIVE	LCCC	FK	20	55	Non-RoHS & Green	SNPB	N / A for Pkg Type	-55 to 125	83025022A SNJ54ALS 569AFK	Samples
SNJ54ALS569AJ	ACTIVE	CDIP	J	20	20	Non-RoHS & Green	SNPB	N / A for Pkg Type	-55 to 125	8302502RA SNJ54ALS569AJ	Samples

(1) The marketing status values are defined as follows:

ACTIVE: Product device recommended for new designs.

LIFEBUY: TI has announced that the device will be discontinued, and a lifetime-buy period is in effect.

NRND: Not recommended for new designs. Device is in production to support existing customers, but TI does not recommend using this part in a new design.

PREVIEW: Device has been announced but is not in production. Samples may or may not be available.

OBSELETE: TI has discontinued the production of the device.

(2) **RoHS:** TI defines "RoHS" to mean semiconductor products that are compliant with the current EU RoHS requirements for all 10 RoHS substances, including the requirement that RoHS substance do not exceed 0.1% by weight in homogeneous materials. Where designed to be soldered at high temperatures, "RoHS" products are suitable for use in specified lead-free processes. TI may reference these types of products as "Pb-Free".

RoHS Exempt: TI defines "RoHS Exempt" to mean products that contain lead but are compliant with EU RoHS pursuant to a specific EU RoHS exemption.

Green: TI defines "Green" to mean the content of Chlorine (Cl) and Bromine (Br) based flame retardants meet JS709B low halogen requirements of <=1000ppm threshold. Antimony trioxide based flame retardants must also meet the <=1000ppm threshold requirement.

(3) MSL, Peak Temp. - The Moisture Sensitivity Level rating according to the JEDEC industry standard classifications, and peak solder temperature.

(4) There may be additional marking, which relates to the logo, the lot trace code information, or the environmental category on the device.

(5) Multiple Device Markings will be inside parentheses. Only one Device Marking contained in parentheses and separated by a "~" will appear on a device. If a line is indented then it is a continuation of the previous line and the two combined represent the entire Device Marking for that device.

(6) Lead finish/Ball material - Orderable Devices may have multiple material finish options. Finish options are separated by a vertical ruled line. Lead finish/Ball material values may wrap to two lines if the finish value exceeds the maximum column width.

Important Information and Disclaimer:The information provided on this page represents TI's knowledge and belief as of the date that it is provided. TI bases its knowledge and belief on information provided by third parties, and makes no representation or warranty as to the accuracy of such information. Efforts are underway to better integrate information from third parties. TI has taken and continues to take reasonable steps to provide representative and accurate information but may not have conducted destructive testing or chemical analysis on incoming materials and chemicals. TI and TI suppliers consider certain information to be proprietary, and thus CAS numbers and other limited information may not be available for release.

In no event shall TI's liability arising out of such information exceed the total purchase price of the TI part(s) at issue in this document sold by TI to Customer on an annual basis.

OTHER QUALIFIED VERSIONS OF SN54ALS569A, SN74ALS569A :

- Catalog : [SN74ALS569A](#)
- Military : [SN54ALS569A](#)

NOTE: Qualified Version Definitions:

- Catalog - TI's standard catalog product
- Military - QML certified for Military and Defense Applications

TAPE AND REEL INFORMATION

QUADRANT ASSIGNMENTS FOR PIN 1 ORIENTATION IN TAPE

*All dimensions are nominal

Device	Package Type	Package Drawing	Pins	SPQ	Reel Diameter (mm)	Reel Width W1 (mm)	A0 (mm)	B0 (mm)	K0 (mm)	P1 (mm)	W (mm)	Pin1 Quadrant
SN74ALS569ADWR	SOIC	DW	20	2000	330.0	24.4	10.8	13.3	2.7	12.0	24.0	Q1

TAPE AND REEL BOX DIMENSIONS

*All dimensions are nominal

Device	Package Type	Package Drawing	Pins	SPQ	Length (mm)	Width (mm)	Height (mm)
SN74ALS569ADWR	SOIC	DW	20	2000	367.0	367.0	45.0

TUBE

*All dimensions are nominal

Device	Package Name	Package Type	Pins	SPQ	L (mm)	W (mm)	T (μm)	B (mm)
83025022A	FK	LCCC	20	55	506.98	12.06	2030	NA
SN74ALS569AN	N	PDIP	20	20	506	13.97	11230	4.32
SNJ54ALS569AFK	FK	LCCC	20	55	506.98	12.06	2030	NA

J (R-GDIP-T**)

14 LEADS SHOWN

CERAMIC DUAL IN-LINE PACKAGE



DIM \ PINS **	14	16	18	20
A	0.300 (7,62) BSC	0.300 (7,62) BSC	0.300 (7,62) BSC	0.300 (7,62) BSC
B MAX	0.785 (19,94)	.840 (21,34)	0.960 (24,38)	1.060 (26,92)
B MIN	—	—	—	—
C MAX	0.300 (7,62)	0.300 (7,62)	0.310 (7,87)	0.300 (7,62)
C MIN	0.245 (6,22)	0.245 (6,22)	0.220 (5,59)	0.245 (6,22)



4040083/F 03/03

- NOTES:
- All linear dimensions are in inches (millimeters).
 - This drawing is subject to change without notice.
 - This package is hermetically sealed with a ceramic lid using glass frit.
 - Index point is provided on cap for terminal identification only on press ceramic glass frit seal only.
 - Falls within MIL STD 1835 GDIP1-T14, GDIP1-T16, GDIP1-T18 and GDIP1-T20.

GENERIC PACKAGE VIEW

FK 20

LCCC - 2.03 mm max height

8.89 x 8.89, 1.27 mm pitch

LEADLESS CERAMIC CHIP CARRIER

This image is a representation of the package family, actual package may vary.
Refer to the product data sheet for package details.



4229370VA\

N (R-PDIP-T**)

PLASTIC DUAL-IN-LINE PACKAGE

16 PINS SHOWN



- NOTES:
- A. All linear dimensions are in inches (millimeters).
 - B. This drawing is subject to change without notice.
 - Falls within JEDEC MS-001, except 18 and 20 pin minimum body length (Dim A).
 - The 20 pin end lead shoulder width is a vendor option, either half or full width.

DW0020A



PACKAGE OUTLINE

SOIC - 2.65 mm max height

SOIC



4220724/A 05/2016

NOTES:

1. All linear dimensions are in millimeters. Dimensions in parenthesis are for reference only. Dimensioning and tolerancing per ASME Y14.5M.
2. This drawing is subject to change without notice.
3. This dimension does not include mold flash, protrusions, or gate burrs. Mold flash, protrusions, or gate burrs shall not exceed 0.15 mm per side.
4. This dimension does not include interlead flash. Interlead flash shall not exceed 0.43 mm per side.
5. Reference JEDEC registration MS-013.

EXAMPLE BOARD LAYOUT

DW0020A

SOIC - 2.65 mm max height

SOIC



LAND PATTERN EXAMPLE
SCALE:6X



SOLDER MASK DETAILS

4220724/A 05/2016

NOTES: (continued)

- 6. Publication IPC-7351 may have alternate designs.
- 7. Solder mask tolerances between and around signal pads can vary based on board fabrication site.

EXAMPLE STENCIL DESIGN

DW0020A

SOIC - 2.65 mm max height

SOIC



SOLDER PASTE EXAMPLE
BASED ON 0.125 mm THICK STENCIL
SCALE:6X

4220724/A 05/2016

NOTES: (continued)

- 8. Laser cutting apertures with trapezoidal walls and rounded corners may offer better paste release. IPC-7525 may have alternate design recommendations.
- 9. Board assembly site may have different recommendations for stencil design.

IMPORTANT NOTICE AND DISCLAIMER

TI PROVIDES TECHNICAL AND RELIABILITY DATA (INCLUDING DATA SHEETS), DESIGN RESOURCES (INCLUDING REFERENCE DESIGNS), APPLICATION OR OTHER DESIGN ADVICE, WEB TOOLS, SAFETY INFORMATION, AND OTHER RESOURCES "AS IS" AND WITH ALL FAULTS, AND DISCLAIMS ALL WARRANTIES, EXPRESS AND IMPLIED, INCLUDING WITHOUT LIMITATION ANY IMPLIED WARRANTIES OF MERCHANTABILITY, FITNESS FOR A PARTICULAR PURPOSE OR NON-INFRINGEMENT OF THIRD PARTY INTELLECTUAL PROPERTY RIGHTS.

These resources are intended for skilled developers designing with TI products. You are solely responsible for (1) selecting the appropriate TI products for your application, (2) designing, validating and testing your application, and (3) ensuring your application meets applicable standards, and any other safety, security, regulatory or other requirements.

These resources are subject to change without notice. TI grants you permission to use these resources only for development of an application that uses the TI products described in the resource. Other reproduction and display of these resources is prohibited. No license is granted to any other TI intellectual property right or to any third party intellectual property right. TI disclaims responsibility for, and you will fully indemnify TI and its representatives against, any claims, damages, costs, losses, and liabilities arising out of your use of these resources.

TI's products are provided subject to [TI's Terms of Sale](#) or other applicable terms available either on [ti.com](https://www.ti.com) or provided in conjunction with such TI products. TI's provision of these resources does not expand or otherwise alter TI's applicable warranties or warranty disclaimers for TI products.

TI objects to and rejects any additional or different terms you may have proposed.

Mailing Address: Texas Instruments, Post Office Box 655303, Dallas, Texas 75265
Copyright © 2024, Texas Instruments Incorporated

Looking for pricing, stock, or lifecycle information?

Click below to explore more details on WIN SOURCE:

 [View SNJ54ALS569AFK on WIN SOURCE](#)

 [Texas Instruments](#) Information

Optimize Your Supply Chain with WIN SOURCE Solutions

-  Global Sourcing Solution
-  Obsolete Management
-  Cost Control Management
-  Shortage Management
-  Alternative Solution
-  Excess Inventory Management