



**THE DATASHEET OF
NB6L16DTG**



NB6L16

2.5 V / 3.3 V Multilevel Input to Differential LVPECL/LVNECL Clock or Data Receiver/ Driver/Translator Buffer

Description

The NB6L16 is a high precision, low power ECL differential clock or data receiver/driver/translator buffer. The device is functionally equivalent to the EL16, EP16, LVEL16 and NBSG16 devices. With output transition times of 70 ps, it is ideally suited for high frequency, low power systems. The device is targeted for Backplane buffering, GbE clock/data distribution, Fibre Channel distribution and SONET clock/data distribution applications.

Input accept LVNECL (Negative ECL), LVPECL (Positive ECL), LVTTTL, LVCMOS, CML, or LVDS. Outputs are 800 mV ECL signals.

The V_{BB} pin, an internally generated voltage supply, is available to this device only. For single-ended input conditions, the unused differential input is connected to V_{BB} as a switching reference voltage. V_{BB} may also rebias AC coupled inputs. When used, decouple V_{BB} and V_{CC} via a 0.01 μ F capacitor and limit current sourcing or sinking to 0.5 mA. When not used, V_{BB} should be left open.

Features

- Input Clock Frequency ≥ 6 GHz
- Input Data Rate Frequency ≥ 6 Gb/s
- Low 12 mA Typical Power Supply Current
- 70 ps Typical Rise/Fall Times
- 130 ps Input Propagation Delay
- On-Chip Reference for ECL Single-Ended Input – V_{BB} Output
- PECL Mode Operating Range:
 $V_{CC} = 2.375$ V to 3.465 V with $V_{EE} = 0$ V
- NECL Mode Operating Range:
 $V_{CC} = 0$ V with $V_{EE} = -2.375$ V to -3.465 V
- Open Input Default State
- LVDS, LVPECL, LVNECL, LVCMOS, LVTTTL and CML Input Compatible
- These Devices are Pb-Free, Halogen Free and are RoHS Compliant



ON Semiconductor®

www.onsemi.com



SOIC-8 NB
D SUFFIX
CASE 751-07



TSSOP-8
DT SUFFIX
CASE 948R-02

MARKING DIAGRAMS*

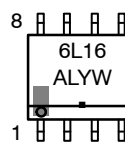

SOIC-8 NB

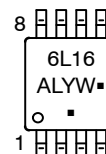

TSSOP-8

- A = Assembly Location
- L = Wafer Lot
- Y = Year
- W = Work Week
- = Pb-Free Package

(Note: Microdot may be in either location)

*For additional marking information, refer to Application Note [AND8002/D](#).

ORDERING INFORMATION

Device	Package	Shipping†
NB6L16DG	SOIC-8 NB (Pb-Free)	98 Units / Tube
NB6L16DR2G	SOIC-8 NB (Pb-Free)	2500 Tape & Reel
NB6L16DTG	TSSOP-8 (Pb-Free)	100 Units / Tube
NB6L16DTR2G	TSSOP-8 (Pb-Free)	2500 Tape & Reel

†For information on tape and reel specifications, including part orientation and tape sizes, please refer to our Tape and Reel Packaging Specifications Brochure, [BRD8011/D](#).

NB6L16

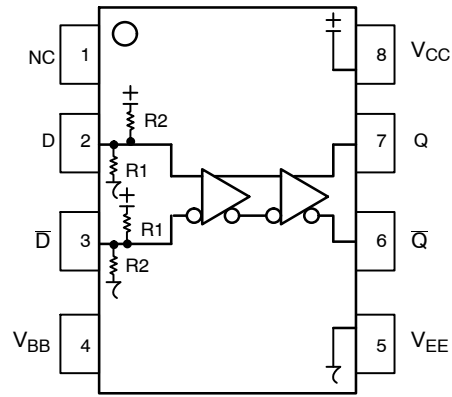

Figure 1. Pinout (Top View) and Logic Diagram

Table 1. PIN DESCRIPTION

Pin	Name	I/O	Default State	Description
1	NC	–	–	No Connect. The NC pin is electrically connected to the die and MUST be left open.
2	D	LVDS, CML, LVPECL, LVNECL, LVTTTL, LVCMOS Input	LOW	Non-inverted differential clock/data input. Internal 75 kΩ to V _{CC} and 37.5 kΩ to V _{EE} .
3	D̄	LVDS, CML, LVPECL, LVNECL, LVTTTL, LVCMOS Input	HIGH	Inverted differential clock/data input. Internal 37.5 kΩ to V _{CC} and 75 kΩ to V _{EE} .
4	V _{BB}	–	–	Internally generated ECL reference voltage supply.
5	V _{EE}	–	–	Negative power supply voltage.
6	Q̄	ECL Output		Inverted differential ECL output. Typically terminated with 50 Ω resistor to V _{CC} – 2.0 V.
7	Q	ECL Output		Non-inverted differential ECL output. Typically terminated with 50 Ω resistor to V _{CC} – 2.0 V.
8	V _{CC}	–	–	Positive power supply voltage.

Table 2. ATTRIBUTES

Characteristics	Value
Internal Input Default State Resistor (R1)	37.5 kΩ
Internal Input Default State Resistor (R2)	75 kΩ
ESD Protection Human Body Model Machine Model Charged Device Model	> 2 kV > 100 V > 1 kV
Moisture Sensitivity, Indefinite Time Out of Drypack (Note 1)	Pb-Free Pkg
SOIC–8 NB TSSOP–8	Level 1 Level 3
Flammability Rating Oxygen Index: 28 to 34	UL 94 V–0 @ 1.125 in
Transistor Count	167
Meets or exceeds JEDEC Spec EIA/JESD78 IC Latchup Test	

1. For additional information, see Application Note [AND8003/D](#).

NB6L16

Table 3. MAXIMUM RATINGS

Symbol	Parameter	Condition 1	Condition 2	Rating	Units
V_{CC}	PECL Mode Power Supply	$V_{EE} = 0\text{ V}$		3.6	V
V_{EE}	NECL Mode Power Supply	$V_{CC} = 0\text{ V}$		-3.6	V
V_I	PECL Mode Input Voltage NECL Mode Input Voltage	$V_{EE} = 0\text{ V}$ $V_{CC} = 0\text{ V}$	$V_I \leq V_{CC}$ $V_I \geq V_{EE}$	3.6 -3.6	V
I_{out}	Output Current	Continuous Surge		25 50	mA
V_{INPP}	Differential Input Voltage $ D - \bar{D} $	$V_{CC} - V_{EE} \geq 2.8\text{ V}$ $V_{CC} - V_{EE} < 2.8\text{ V}$		2.8 $ V_{CC} - V_{EE} $	V
I_{BB}	V_{BB} Sink/Source			± 0.5	mA
T_A	Operating Temperature Range			-40 to +85	$^{\circ}\text{C}$
T_{stg}	Storage Temperature Range			-65 to +150	$^{\circ}\text{C}$
θ_{JA}	Thermal Resistance (Junction-to-Ambient)	0 lfpm 500 lfpm	SOIC-8 NB SOIC-8 NB	190 130	$^{\circ}\text{C}/\text{W}$
θ_{JC}	Thermal Resistance (Junction-to-Case)	Standard Board	SOIC-8 NB	41 to 44	$^{\circ}\text{C}/\text{W}$
θ_{JA}	Thermal Resistance (Junction-to-Ambient)	0 lfpm 500 lfpm	TSSOP-8 TSSOP-8	185 140	$^{\circ}\text{C}/\text{W}$
θ_{JC}	Thermal Resistance (Junction-to-Case)	Standard Board	TSSOP-8	41 to 44	$^{\circ}\text{C}/\text{W}$
T_{sol}	Wave Solder	Standard Pb-Free	$\leq 3\text{ sec @ } 248^{\circ}\text{C}$ $\leq 3\text{ sec @ } 260^{\circ}\text{C}$	265 265	$^{\circ}\text{C}$

Stresses exceeding those listed in the Maximum Ratings table may damage the device. If any of these limits are exceeded, device functionality should not be assumed, damage may occur and reliability may be affected.

NB6L16

Table 4. DC CHARACTERISTICS, PECL ($V_{CC} = 2.5\text{ V}$, $V_{EE} = 0\text{ V}$ (Note 3))

Symbol	Characteristic	-40°C			25°C			85°C			Unit
		Min	Typ	Max	Min	Typ	Max	Min	Typ	Max	
I_{EE}	Negative Power Supply Current (Note 4)	10	12	18	10	12	18	10	12	18	mA
V_{OH}	Output HIGH Voltage (Note 5)	1350	1450	1550	1400	1500	1600	1450	1550	1650	mV
V_{OL}	Output LOW Voltage (Note 5)	565	725	870	630	765	920	690	825	970	mV

DIFFERENTIAL INPUT DRIVEN Single-Ended ((Figures 10, 12) (Note 7))

V_{th}	Input Threshold Reference Voltage Range (Notes 1, 6)	1125		V_{CC} -75	1125		V_{CC} -75	1125		V_{CC} -75	mV
V_{IH}	Single-Ended Input HIGH Voltage	V_{th} +75		V_{CC}	V_{th} +75		V_{CC}	V_{th} +75		V_{CC}	mV
V_{IL}	Single-Ended Input LOW Voltage	V_{EE}		V_{th} -75	V_{EE}		V_{th} -75	V_{EE}		V_{th} -75	mV

DIFFERENTIAL INPUTS DRIVEN DIFFERENTIALLY ((Figures 11, 13) (Note 8))

V_{IHD}	Differential Input HIGH Voltage	1200		V_{CC}	1200		V_{CC}	1200		V_{CC}	mV
V_{ILD}	Differential Input LOW Voltage	V_{EE}		V_{CC} -75	V_{EE}		V_{CC} -75	V_{EE}		V_{CC} -75	mV
V_{CMR}	Input Common Mode Range (Differential Cross-Point Voltage) (Note 2)	950		V_{CC} -38	950		V_{CC} -38	950		V_{CC} -38	mV
V_{ID}	Differential Input Voltage ($V_{IHD} - V_{ILD}$)	75		2500	75		2500	75		2500	mV
I_{IH}	Input HIGH Current D \bar{D}		50 10	150 150		50 10	150 150		50 10	150 150	μA
I_{IL}	Input LOW Current D \bar{D}	-150 -150	-5 -30		-150 -150	-5 -30		-150 -150	-5 -30		μA

NOTE: Device will meet the specifications after thermal equilibrium has been established when mounted in a test socket or printed circuit board with maintained transverse airflow greater than 500 lfm. Electrical parameters are guaranteed only over the declared operating temperature range. Functional operation of the device exceeding these conditions is not implied. Device specification limit values are applied individually under normal operating conditions and not valid simultaneously.

- V_{th} is applied to the complementary input when operating in Single-Ended mode.
- V_{CMR} minimum varies 1:1 with V_{EE} , V_{CMR} maximum varies 1:1 with V_{CC} .
- Input and output parameters vary 1:1 with V_{CC} . V_{EE} can vary +0.125 V to -1.3 V.
- All input and output pins left open.
- All loading with 50 Ω to $V_{CC} - 2.0\text{ V}$.
- Do not use V_{BB} as a reference voltage for Single-Ended PECL signals when operating device at $V_{CC} - V_{EE} < 3.0\text{ V}$.
- V_{th} , V_{IH} , and V_{IL} parameters must be complied with simultaneously.
- V_{IHD} , V_{ILD} , V_{ID} and V_{CMR} parameters must be complied with simultaneously.

NB6L16

Table 5. DC CHARACTERISTICS, PECL ($V_{CC} = 3.3\text{ V}$, $V_{EE} = 0\text{ V}$ (Note 3))

Symbol	Characteristic	-40°C			25°C			85°C			Unit
		Min	Typ	Max	Min	Typ	Max	Min	Typ	Max	
I_{EE}	Negative Power Supply Current (Note 4)	10	12	18	10	12	18	10	12	18	mA
V_{OH}	Output HIGH Voltage (Note 5)	2150	2250	2350	2200	2300	2400	2250	2350	2450	mV
V_{OL}	Output LOW Voltage (Note 5)	1365	1525	1670	1430	1565	1720	1490	1625	1770	mV

DIFFERENTIAL INPUT DRIVEN Single-Ended ((Figures 10, 12) (Note 6))

V_{th}	Input Threshold Reference Voltage Range (Note 1)	1125		$V_{CC} - 75$	1125		$V_{CC} - 75$	1125		$V_{CC} - 75$	mV
V_{IH}	Single-Ended Input HIGH Voltage	$V_{th} + 75$		V_{CC}	$V_{th} + 75$		V_{CC}	$V_{th} + 75$		V_{CC}	mV
V_{IL}	Single-Ended Input LOW Voltage	V_{EE}		$V_{th} - 75$	V_{EE}		$V_{th} - 75$	V_{EE}		$V_{th} - 75$	mV
V_{BB}	Output Voltage Reference	1880	1980	2070	1880	1980	2070	1880	1980	2070	mV

DIFFERENTIAL INPUTS DRIVEN DIFFERENTIALLY ((Figures 11, 13) (Note 7))

V_{IHD}	Differential Input HIGH Voltage	1200		V_{CC}	1200		V_{CC}	1200		V_{CC}	mV
V_{ILD}	Differential Input LOW Voltage	V_{EE}		$V_{CC} - 75$	V_{EE}		$V_{CC} - 75$	V_{EE}		$V_{CC} - 75$	mV
V_{CMR}	Input Common Mode Range (Differential Cross-Point Voltage) (Note 2)	950		$V_{CC} - 38$	950		$V_{CC} - 38$	950		$V_{CC} - 38$	mV
V_{ID}	Differential Input Voltage ($V_{IHD} - V_{ILD}$)	75		2500	75		2500	75		2500	mV
I_{IH}	Input HIGH Current D \bar{D}		50 10	150 150		50 10	150 150		50 10	150 150	μA
I_{IL}	Input LOW Current D \bar{D}	-150 -150	-5 -30		-150 -150	-5 -30		-150 -150	-5 -30		μA

NOTE: Device will meet the specifications after thermal equilibrium has been established when mounted in a test socket or printed circuit board with maintained transverse airflow greater than 500 lpm. Electrical parameters are guaranteed only over the declared operating temperature range. Functional operation of the device exceeding these conditions is not implied. Device specification limit values are applied individually under normal operating conditions and not valid simultaneously.

- V_{th} is applied to the complementary input when operating in Single-Ended mode.
- V_{CMR} minimum varies 1:1 with V_{EE} , V_{CMR} maximum varies 1:1 with V_{CC} .
- Input and output parameters vary 1:1 with V_{CC} . V_{EE} can vary +0.925 V to -0.5 V.
- All input and output pins left open.
- All loading with 50 Ω to $V_{CC} - 2.0\text{ V}$.
- V_{th} , V_{IH} , and V_{IL} parameters must be complied with simultaneously.
- V_{IHD} , V_{ILD} , V_{ID} and V_{CMR} parameters must be complied with simultaneously.

NB6L16

Table 6. DC CHARACTERISTICS, NECL ($V_{CC} = 0\text{ V}$, $V_{EE} = -3.465\text{ V}$ to -2.375 V (Note 3))

Symbol	Characteristic	-40°C			25°C			85°C			Unit
		Min	Typ	Max	Min	Typ	Max	Min	Typ	Max	
I_{EE}	Negative Power Supply Current (Note 5)	10	12	18	10	12	18	10	12	18	mA
V_{OH}	Output HIGH Voltage (Note 4)	-1150	-1050	-950	-1100	-1000	-900	-1050	-950	-850	mV
V_{OL}	Output LOW Voltage (Note 4)	-1935	-1775	-1630	-1870	-1735	-1580	-1810	-1675	-1530	mV

DIFFERENTIAL INPUT DRIVEN Single-Ended ((Figures 10, 12) (Note 6))

V_{th}	Input Threshold Reference Voltage Range (Note 1)	$V_{EE} +1125$		$V_{CC} -75$	$V_{EE} +1125$		$V_{CC} -75$	$V_{EE} +1125$		$V_{CC} -75$	mV
V_{IH}	Single-Ended Input HIGH Voltage	$V_{th} +75$		V_{CC}	$V_{th} +75$		V_{CC}	$V_{th} +75$		V_{CC}	mV
V_{IL}	Single-Ended Input LOW Voltage	V_{EE}		$V_{th} -75$	V_{EE}		$V_{th} -75$	V_{EE}		$V_{th} -75$	mV
V_{BB}	Output Voltage Reference	-1420	-1320	-1230	-1420	-1320	-1230	-1420	-1320	-1230	mV

DIFFERENTIAL INPUTS DRIVEN DIFFERENTIALLY ((Figures 11, 13) (Note 7))

V_{IHD}	Differential Input HIGH Voltage	$V_{EE} +1200$		V_{CC}	$V_{EE} +1200$		V_{CC}	$V_{EE} +1200$		V_{CC}	mV
V_{ILD}	Differential Input LOW Voltage	V_{EE}		$V_{CC} -75$	V_{EE}		$V_{CC} -75$	V_{EE}		$V_{CC} -75$	mV
V_{CMR}	Input Common Mode Range (Differential Cross-Point Voltage) (Note 2)	$V_{EE} +950$		$V_{CC} -38$	$V_{EE} +950$		$V_{CC} -38$	$V_{EE} +950$		$V_{CC} -38$	mV
V_{ID}	Differential Input Voltage ($V_{IHD} - V_{ILD}$)	75		2500	75		2500	75		2500	mV
I_{IH}	Input HIGH Current $\frac{D}{\bar{D}}$		50 10	150 150		50 10	150 150		50 10	150 150	μA
I_{IL}	Input LOW Current $\frac{D}{\bar{D}}$	-150 -150	-5 -30	-150 -150	-5 -30	-150 -150	-5 -30	-150 -150	-5 -30	-150 -150	μA

NOTE: Device will meet the specifications after thermal equilibrium has been established when mounted in a test socket or printed circuit board with maintained transverse airflow greater than 500 lfm. Electrical parameters are guaranteed only over the declared operating temperature range. Functional operation of the device exceeding these conditions is not implied. Device specification limit values are applied individually under normal operating conditions and not valid simultaneously.

1. V_{th} is applied to the complementary input when operating in Single-Ended mode.
2. V_{CMR} minimum varies 1:1 with V_{EE} , V_{CMR} maximum varies 1:1 with V_{CC} .
3. Input and output parameters vary 1:1 with V_{CC} .
4. All loading with $50\ \Omega$ to $V_{CC} - 2.0\text{ V}$.
5. All input and output pins left open.
6. V_{th} , V_{IH} , and V_{IL} parameters must be complied with simultaneously.
7. V_{IHD} , V_{ILD} , V_{ID} and V_{CMR} parameters must be complied with simultaneously.

NB6L16

Table 7. AC CHARACTERISTICS ($V_{CC} = 0\text{ V}$; $V_{EE} = -3.465\text{ V}$ to -2.375 V or $V_{CC} = 2.375\text{ V}$ to 3.465 V ; $V_{EE} = 0\text{ V}$ (Note 1))

Symbol	Characteristic	-40°C			25°C			85°C			Unit
		Min	Typ	Max	Min	Typ	Max	Min	Typ	Max	
V_{OUTPP}	Output Voltage Amplitude $f_{in} < 3\text{ GHz}$ $f_{in} < 6\text{ GHz}$ (See Figures 2 & 3)	500 270	700 350		500 270	700 350		500 270	700 300		mV
f_{DATA}	Maximum Operating Data Rate	6									Gb/s
t_{PLH} , t_{PHL}	Propagation Delay to Output Differential @ 1 GHz	80	130	180	80	130	180	85	135	185	ps
t_{SKEW}	Duty Cycle Skew (Note 2) Device-to-Device Skew		3 30	25 60		3 30	25 60		3 30	25 60	ps
t_{JITTER}	RMS Random Clock Jitter $f_{in} < 6\text{ GHz}$ (Note 3) Peak-to-Peak Data Dependent Jitter $f_{in} < 6\text{ Gb/s}$ (Note 4)		0.2 2	1 12		0.2 2	1 12		0.2 2	1 12	ps
V_{INPP}	Input Voltage Swing / Sensitivity (Differential Configuration) (Note 5)	75	700	2500	75	700	2500	75	700	2500	mV
t_r t_f	Output Rise/Fall Times (20%–80%) Q, \bar{Q}	30	70	120	30	70	120	30	70	120	ps

NOTE: Device will meet the specifications after thermal equilibrium has been established when mounted in a test socket or printed circuit board with maintained transverse airflow greater than 500 lfm. Electrical parameters are guaranteed only over the declared operating temperature range. Functional operation of the device exceeding these conditions is not implied. Device specification limit values are applied individually under normal operating conditions and not valid simultaneously.

1. Measured using a 800 mV source, 50% duty cycle clock source. All loading with $50\ \Omega$ to V_{CC} . Input edge rates 40 ps (20% – 80%).
2. See Figure 9 $t_{skew} = |t_{PLH} - t_{PHL}|$ for a nominal 50% differential clock input waveform. Skew is measured between outputs under identical transitions and conditions @ 1 GHz.
3. Additive RMS jitter with 50% duty cycle clock signal at 6 GHz.
4. Additive Peak-to-Peak data dependent jitter with NRZ PRBS $2^{23}-1$ data rate at 6 Gb/s.
5. $V_{INPP(max)}$ cannot exceed $V_{CC} - V_{EE}$. (Applicable only when $V_{CC} - V_{EE} < 2500\text{ mV}$). Input voltage swing is a single-ended measurement operating in the differential mode.

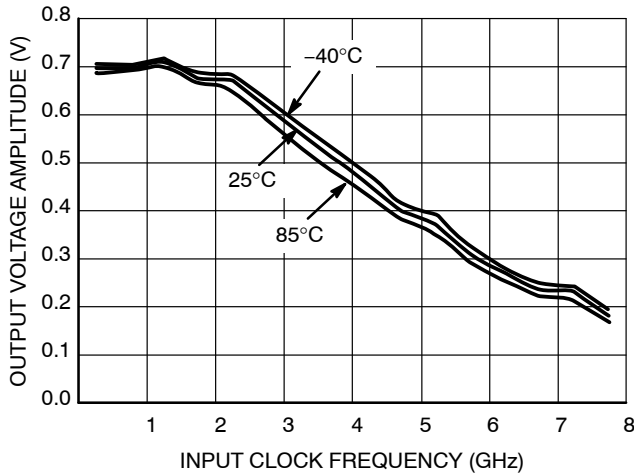

Figure 2. Output Voltage Amplitude (V_{OUTPP}) versus Input Clock Frequency (f_{IN}) and Temperature at $V_{CC} - V_{EE} = 3.3\text{ V}$

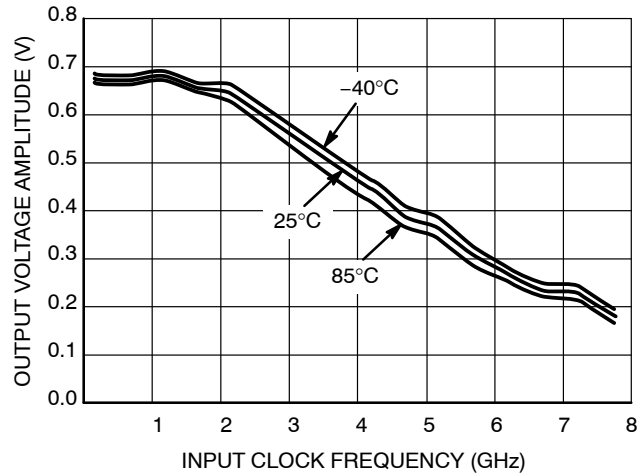

Figure 3. Output Voltage Amplitude (V_{OUTPP}) versus Input Clock Frequency (f_{IN}) and Temperature at $V_{CC} - V_{EE} = 2.5\text{ V}$

NB6L16

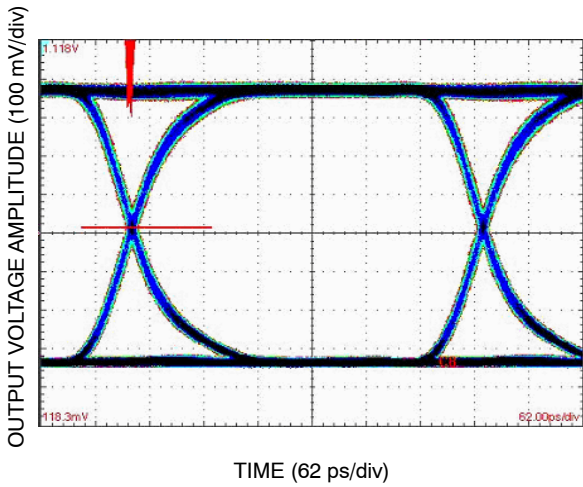

Figure 4. Typical Output Waveform at 2.488 Gb/s with PRBS 2²³-1 (Total System Pk-Pk Jitter is 16 ps. Device Pk-Pk Jitter Contribution is 3 ps)

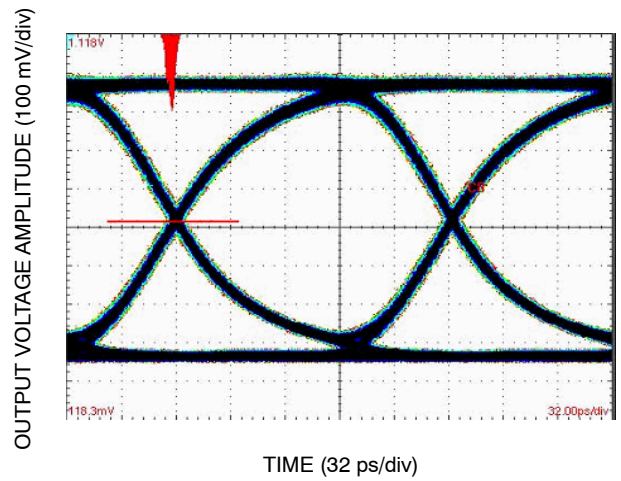

Figure 5. Typical Output Waveform at 6.125 Gb/s with PRBS 2²³-1 (Total System Pk-Pk Jitter is 17 ps. Device Pk-Pk Jitter Contribution is 4 ps)

NOTE: $V_{CC} - V_{EE} = 3.3 \text{ V}$; $V_{IN} = 700 \text{ mV}$; $T_A = 25^\circ\text{C}$.

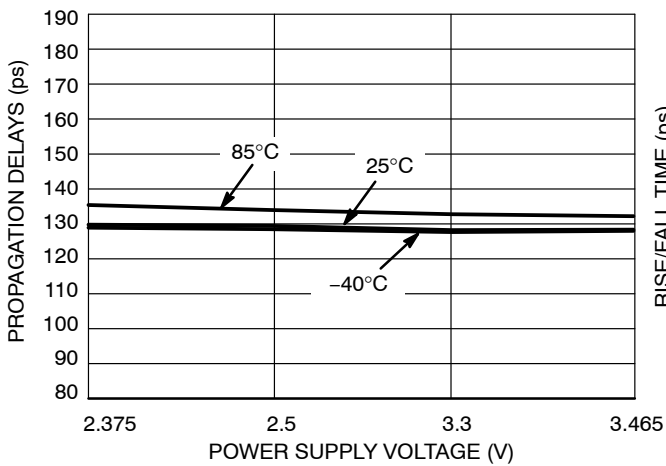

Figure 6. Propagation Delay versus Power Supply Voltage and Temperature

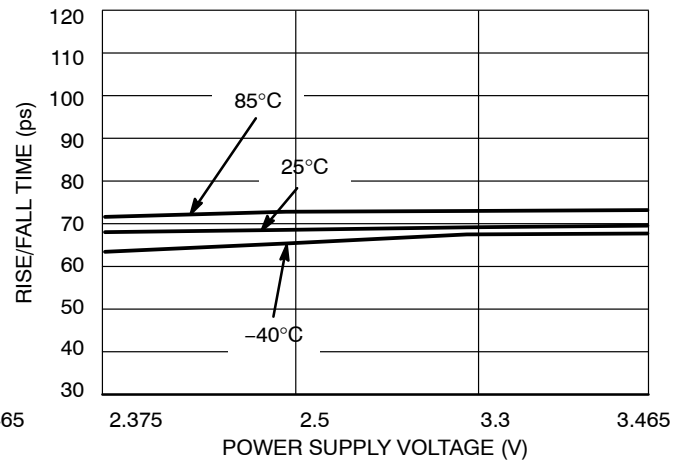

Figure 7. Rise/Fall Time versus Power Supply Voltage and Temperature

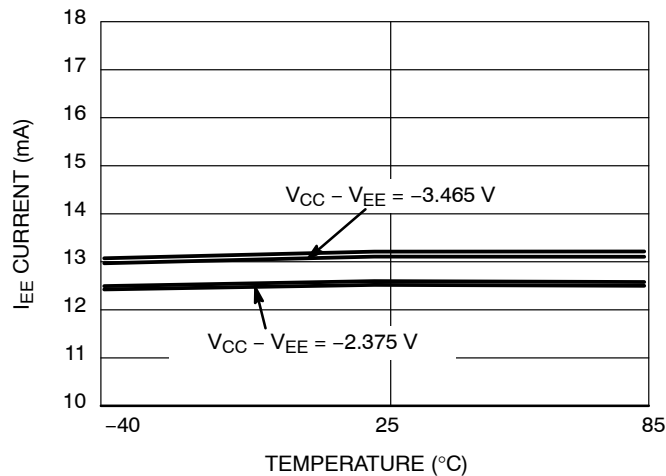

Figure 8. I_{EE} Current versus Temperature and Power Supply Voltage

NB6L16

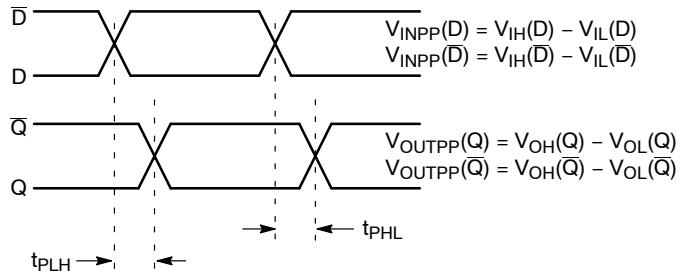

Figure 9. AC Reference Measurement

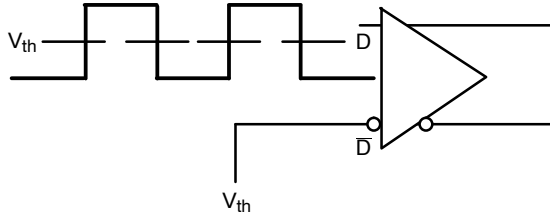

Figure 10. Differential Input Driven Single-Ended

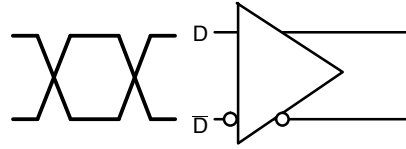

Figure 11. Differential Inputs Driven Differentially

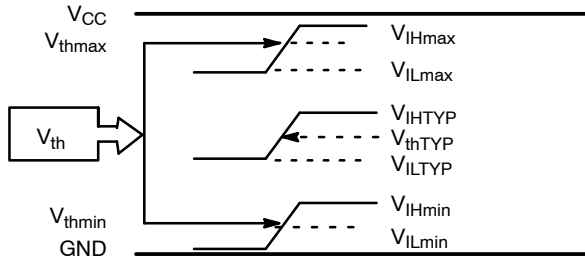

Figure 12. V_{th} Diagram

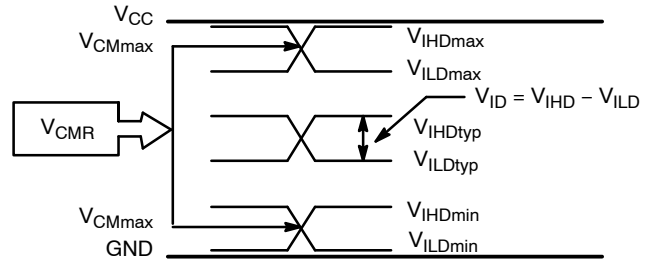

Figure 13. V_{CMR} Diagram

NB6L16

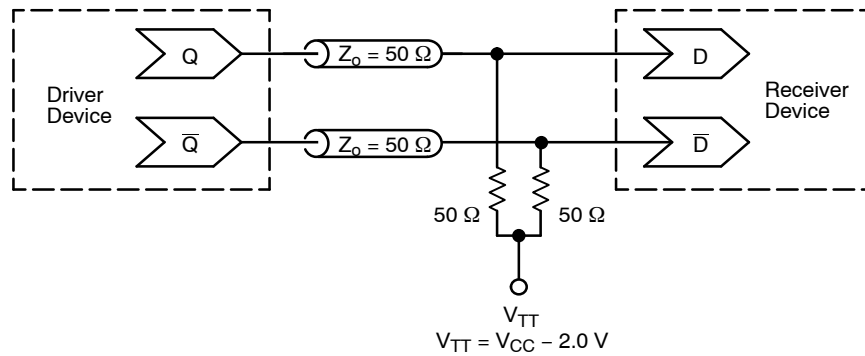

Figure 14. Typical Termination for Output Driver and Device Evaluation
(See Application Note [AND8020/D](#) – Termination of ECL Logic Devices)

Resource Reference of Application Notes

- AN1405/D** – ECL Clock Distribution Techniques
- AN1406/D** – Designing with PECL (ECL at +5.0 V)
- AN1503/D** – ECLinPS™ I/O SPICE Modeling Kit
- AN1504/D** – Metastability and the ECLinPS Family
- AN1568/D** – Interfacing Between LVDS and ECL
- AN1672/D** – The ECL Translator Guide
- AND8001/D** – Odd Number Counters Design
- AND8002/D** – Marking and Date Codes
- AND8020/D** – Termination of ECL Logic Devices
- AND8066/D** – Interfacing with ECLinPS
- AND8090/D** – AC Characteristics of ECL Devices

NB6L16

PACKAGE DIMENSIONS

SOIC-8 NB
D SUFFIX
CASE 751-07
ISSUE AK

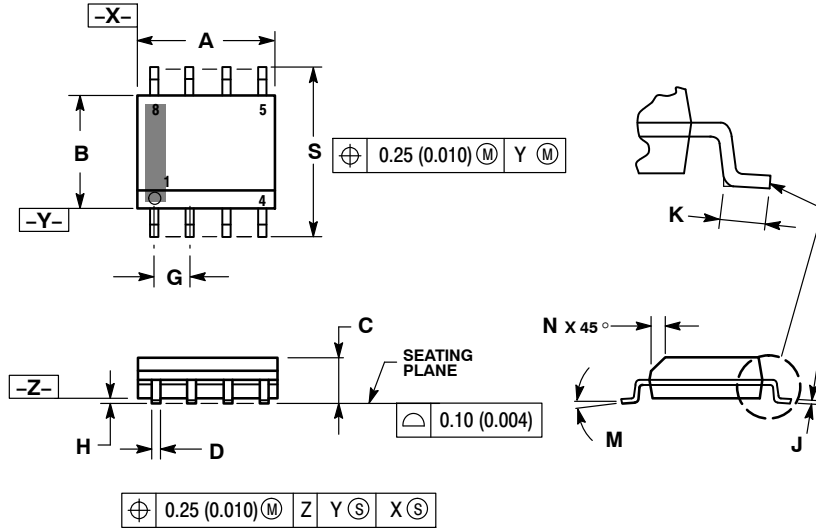

- NOTES:
1. DIMENSIONING AND TOLERANCING PER ANSI Y14.5M, 1982.
 2. CONTROLLING DIMENSION: MILLIMETER.
 3. DIMENSION A AND B DO NOT INCLUDE MOLD PROTRUSION.
 4. MAXIMUM MOLD PROTRUSION 0.15 (0.006) PER SIDE.
 5. DIMENSION D DOES NOT INCLUDE DAMBAR PROTRUSION. ALLOWABLE DAMBAR PROTRUSION SHALL BE 0.127 (0.005) TOTAL IN EXCESS OF THE D DIMENSION AT MAXIMUM MATERIAL CONDITION.
 6. 751-01 THRU 751-06 ARE OBSOLETE. NEW STANDARD IS 751-07.

DIM	MILLIMETERS		INCHES	
	MIN	MAX	MIN	MAX
A	4.80	5.00	0.189	0.197
B	3.80	4.00	0.150	0.157
C	1.35	1.75	0.053	0.069
D	0.33	0.51	0.013	0.020
G	1.27 BSC		0.050 BSC	
H	0.10	0.25	0.004	0.010
J	0.19	0.25	0.007	0.010
K	0.40	1.27	0.016	0.050
M	0°	8°	0°	8°
N	0.25	0.50	0.010	0.020
S	5.80	6.20	0.228	0.244

SOLDERING FOOTPRINT*

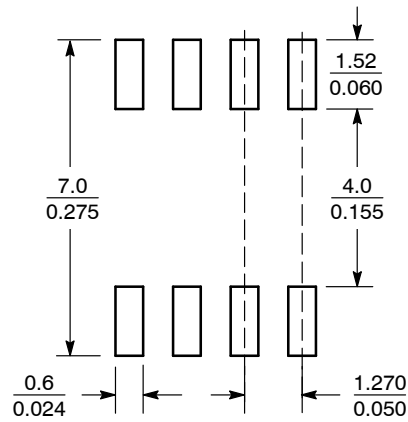

SCALE 6:1 ($\frac{\text{mm}}{\text{inches}}$)

*For additional information on our Pb-Free strategy and soldering details, please download the ON Semiconductor Soldering and Mounting Techniques Reference Manual, SOLDERRM/D.

NB6L16

PACKAGE DIMENSIONS

TSSOP-8
DT SUFFIX
CASE 948R-02
ISSUE A

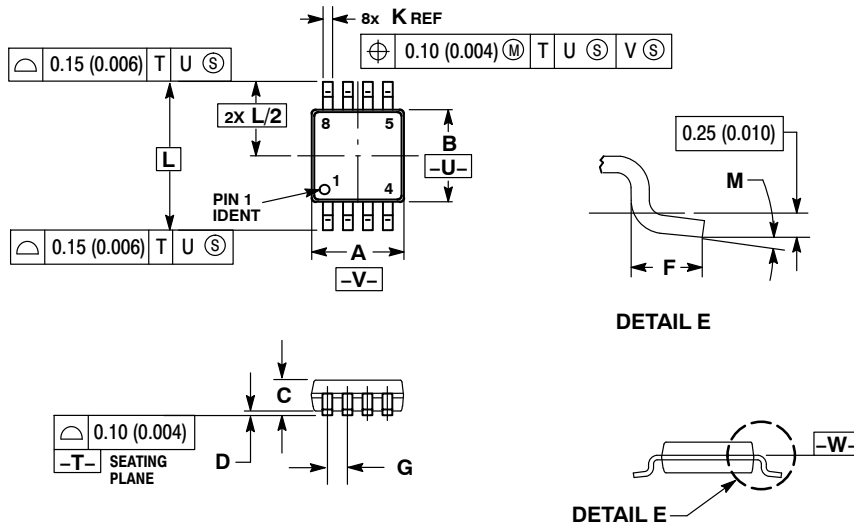

NOTES:

1. DIMENSIONING AND TOLERANCING PER ANSI Y14.5M, 1982.
2. CONTROLLING DIMENSION: MILLIMETER.
3. DIMENSION A DOES NOT INCLUDE MOLD FLASH, PROTRUSIONS OR GATE BURRS. MOLD FLASH OR GATE BURRS SHALL NOT EXCEED 0.15 (0.006) PER SIDE.
4. DIMENSION B DOES NOT INCLUDE INTERLEAD FLASH OR PROTRUSION. INTERLEAD FLASH OR PROTRUSION SHALL NOT EXCEED 0.25 (0.010) PER SIDE.
5. TERMINAL NUMBERS ARE SHOWN FOR REFERENCE ONLY.
6. DIMENSION A AND B ARE TO BE DETERMINED AT DATUM PLANE -W-.

DIM	MILLIMETERS		INCHES	
	MIN	MAX	MIN	MAX
A	2.90	3.10	0.114	0.122
B	2.90	3.10	0.114	0.122
C	0.80	1.10	0.031	0.043
D	0.05	0.15	0.002	0.006
F	0.40	0.70	0.016	0.028
G	0.65 BSC		0.026 BSC	
K	0.25	0.40	0.010	0.016
L	4.90 BSC		0.193 BSC	
M	0°	6°	0°	6°

ECLinPS is a trademark of Semiconductor Components Industries, LLC (SCILLC) or its subsidiaries in the United States and/or other countries.

ON Semiconductor and are trademarks of Semiconductor Components Industries, LLC dba ON Semiconductor or its subsidiaries in the United States and/or other countries. ON Semiconductor owns the rights to a number of patents, trademarks, copyrights, trade secrets, and other intellectual property. A listing of ON Semiconductor's product/patent coverage may be accessed at www.onsemi.com/site/pdf/Patent-Marketing.pdf. ON Semiconductor reserves the right to make changes without further notice to any products herein. ON Semiconductor makes no warranty, representation or guarantee regarding the suitability of its products for any particular purpose, nor does ON Semiconductor assume any liability arising out of the application or use of any product or circuit, and specifically disclaims any and all liability, including without limitation special, consequential or incidental damages. Buyer is responsible for its products and applications using ON Semiconductor products, including compliance with all laws, regulations and safety requirements or standards, regardless of any support or applications information provided by ON Semiconductor. "Typical" parameters which may be provided in ON Semiconductor data sheets and/or specifications can and do vary in different applications and actual performance may vary over time. All operating parameters, including "Typicals" must be validated for each customer application by customer's technical experts. ON Semiconductor does not convey any license under its patent rights nor the rights of others. ON Semiconductor products are not designed, intended, or authorized for use as a critical component in life support systems or any FDA Class 3 medical devices or medical devices with a same or similar classification in a foreign jurisdiction or any devices intended for implantation in the human body. Should Buyer purchase or use ON Semiconductor products for any such unintended or unauthorized application, Buyer shall indemnify and hold ON Semiconductor and its officers, employees, subsidiaries, affiliates, and distributors harmless against all claims, costs, damages, and expenses, and reasonable attorney fees arising out of, directly or indirectly, any claim of personal injury or death associated with such unintended or unauthorized use, even if such claim alleges that ON Semiconductor was negligent regarding the design or manufacture of the part. ON Semiconductor is an Equal Opportunity/Affirmative Action Employer. This literature is subject to all applicable copyright laws and is not for resale in any manner.

PUBLICATION ORDERING INFORMATION

LITERATURE FULFILLMENT:
Literature Distribution Center for ON Semiconductor
19521 E. 32nd Pkwy, Aurora, Colorado 80011 USA
Phone: 303-675-2175 or 800-344-3860 Toll Free USA/Canada
Fax: 303-675-2176 or 800-344-3867 Toll Free USA/Canada
Email: orderlit@onsemi.com

N. American Technical Support: 800-282-9855 Toll Free
USA/Canada
Europe, Middle East and Africa Technical Support:
Phone: 421 33 790 2910
Japan Customer Focus Center
Phone: 81-3-5817-1050

ON Semiconductor Website: www.onsemi.com
Order Literature: <http://www.onsemi.com/orderlit>

For additional information, please contact your local Sales Representative

Looking for pricing, stock, or lifecycle information?

Click below to explore more details on WIN SOURCE:

 [View NB6L16DTG on WIN SOURCE](#)

 [ON Semiconductor](#) Information

Optimize Your Supply Chain with WIN SOURCE Solutions

-  Global Sourcing Solution
-  Obsolete Management
-  Cost Control Management
-  Shortage Management
-  Alternative Solution
-  Excess Inventory Management