

## Class 2 Bluetooth® Module with EDR Support

### Features

- Fully qualified Bluetooth® version 2.1 module, supports version 2.1 + Enhanced Data Rate (EDR)
- ASCII command interface over UART
- Postage-stamp-sized form factor:
  - RN42: 13.4 x 25.8 x 2.4 mm
  - RN42N: 13.4 x 20.5 x 2.4 mm
- Low-power (26 µA sleep, 3 mA connected, 30 mA transmit)
- UART (SPP or HCI) and USB (HCI only) data connection interfaces
- Sustained SPP data rates: 240 Kbps (Slave mode), 300 Kbps (Master mode)
- HCI data rates: 1.5 Mbps sustained, 3.0 Mbps burst in HCI mode
- Embedded Bluetooth stack profiles include: GAP, SDP, RFCOMM, L2CAP protocols, with SPP, HID, and DUN profile support (does not require any host stack).
- Bluetooth SIG qualified, end product listing
- Castellated SMT pads for easy and reliable PCB mounting
- Class 2 power amplifier with on-board PCB trace antenna (RN42) or external antenna (RN42N)
- Compliance (RN42)
  - Modular Certified for the United States (FCC) and Canada (IC)
  - European R&TTE Directive Assessed Radio Module
  - Australia/New Zealand/Japan/Korea/Taiwan
  - Bluetooth SIG QDID
- Integrated Crystal, Internal Voltage Regulator,



Matching Circuitry, Power Amplifier, Low Noise, Memory Amplifier and PCB Antenna

- Easy Integration into Final Product - Minimize Product Development, Quicker Time to Market
- Compatible with Microchip Microcontroller Families (PIC16F, PIC18F, PIC24F/H, dsPIC33 and PIC32)
- Up to 10 meter range

### Applications

- Cable replacement
- Barcode scanners
- Measurement and monitoring systems
- Industrial sensors and controls
- Medical devices

**RN42/RN42N Module Variants<sup>(1)</sup>**

Model	Antenna	Firmware	Description
RN42	Integral	4.77, 6.15	Class 2, 2.1+EDR, SPP profile
RN42HCI	Integral	N/A	Class 2, 2.0+EDR, HCI over UART
RN42HID	Integral	6.11	Class 2, 2.1+EDR, HID and SPP profiles
RN42U	Integral	N/A	Class 2, 2.0+EDR, HCI over USB
RN42APL	Integral	5.36, 5.43, 5.45	Class 2, 2.1+EDR, SPP & MFi profiles
RN42N	External	4.77, 6.15	Class 2, 2.1+EDR, SPP profile
RN42NHCI	External	N/A	Class 2, 2.0+EDR, HCI over UART
RN42NHID	External	6.11	Class 2, 2.1+EDR, HID and SPP profiles
RN42NU	External	N/A	Class 2, 2.0+EDR, HCI over USB
RN42NAPL	External	5.36, 5.43, 5.45	Class 2, 2.1+EDR, SPP & MFi profiles

**Note 1:** For customer part numbers, see **Section 4.0 “Ordering Information”**. Information on firmware versions can be found on the RN42/RN42N product web page and the “Bluetooth Data Module Command Reference and Advanced Information User’s Guide”.

# RN42/RN42N

---

## Table of Contents

1.0 Device Overview .....	3
2.0 Application Information.....	7
3.0 Regulatory Approval.....	12
4.0 Ordering Information .....	18
Appendix A: Revision History.....	19
The Microchip Web Site.....	21
Customer Change Notification Service.....	21
Customer Support.....	21
Product Identification System .....	23

### TO OUR VALUED CUSTOMERS

It is our intention to provide our valued customers with the best documentation possible to ensure successful use of your Microchip products. To this end, we will continue to improve our publications to better suit your needs. Our publications will be refined and enhanced as new volumes and updates are introduced.

If you have any questions or comments regarding this publication, please contact the Marketing Communications Department via E-mail at [docerrors@microchip.com](mailto:docerrors@microchip.com). We welcome your feedback.

#### Most Current Data Sheet

To obtain the most up-to-date version of this data sheet, please register at our Worldwide Web site at:

<http://www.microchip.com>

You can determine the version of a data sheet by examining its literature number found on the bottom outside corner of any page. The last character of the literature number is the version number, (e.g., DS3000000A is version A of document DS3000000).

#### Errata

An errata sheet, describing minor operational differences from the data sheet and recommended workarounds, may exist for current devices. As device/documentation issues become known to us, we will publish an errata sheet. The errata will specify the revision of silicon and revision of document to which it applies.

To determine if an errata sheet exists for a particular device, please check with one of the following:

- Microchip's Worldwide Web site; <http://www.microchip.com>
- Your local Microchip sales office (see last page)

When contacting a sales office, please specify which device, revision of silicon and data sheet (include literature number) you are using.

#### Customer Notification System

Register on our web site at [www.microchip.com](http://www.microchip.com) to receive the most current information on all of our products.

## 1.0 DEVICE OVERVIEW

The RN42/RN42N module is a small form factor, low-power, class 2 Bluetooth radio that is ideal for designers who want to add wireless capability to their products without spending significant time and money developing Bluetooth-specific hardware and software. The RN42/RN42N supports multiple interface protocols, is simple to design in, and is fully certified, making it a complete embedded Bluetooth solution. With its high-performance, PCB trace antenna (RN42) or external antenna (RN42N), and support for Bluetooth EDR, the RN42/RN42N delivers up to a 3-Mbps data rate for distances up to 10 meters.

### 1.1 MCU Interface

The RN42/RN42N module is managed through ASCII commands via the UART and/or PIO signals. A microcontroller unit (MCU) or host processor sends commands to configure module features, read status, and manage Bluetooth data connections.

As shown in Figure 1-1, the UART TX and RX are required to communicate with module, and transfer data across Bluetooth SPP connection.

Connecting the hardware flow control lines CTS and RTS is highly recommended for applications that transmits a continuous stream of data.

The module can be configured locally via the UART or over-the-air. To support instant cable replacement, auto-discovery/pairing does not require software configuration. Additionally, the module supports auto-connect master, I/O pin (DTR), and character-based trigger modes.

FIGURE 1-1: RN42/RN42N TO MCU INTERFACE

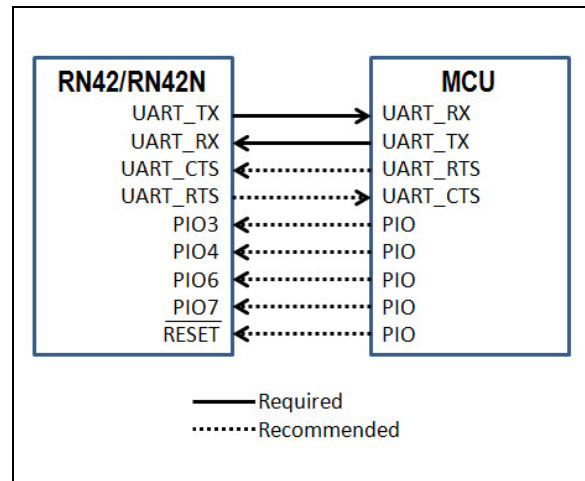

Table 1-1, Table 1-2, Table 1-3, Table 1-4, and Table 1-5 provide the module's environmental conditions, electrical characteristics, dimensions, radio characteristics, and digital I/O characteristics.

### 1.2 ASCII Command and Data Interface

The "Bluetooth Data Module Advanced User's Guide" provides a complete description of the ASCII command and data interface for the RN42/RN42N module.

TABLE 1-1: ENVIRONMENTAL CONDITIONS

Parameter	Value
Temperature Range (Operating)	-40° C ~ 85° C
Temperature Range (Storage)	-40° C ~ 85° C
Relative Humidity (Operating)	≤ 90%
Relative Humidity (Storage)	≤ 90%
Moisture Sensitivity Level	1

TABLE 1-2: ELECTRICAL CHARACTERISTICS

Parameter	Min.	Typ.	Max.	Units
Supply Voltage (DC)	3.0	3.3	3.6	V
Average Power Consumption				
Radio On (Discovery or Inquiry Window Time) <sup>(1)</sup>	—	40	—	mA
Connected Idle (No Sniff)	—	25	—	mA
Connected Idle (Sniff 100 ms)	—	12	—	mA
Connected with Data Transfer	40	45	50	mA
Deep Sleep Idle Mode	—	26	—	μA

**Note 1:** This characteristic applies if, in Slave mode, there are bursts of radio on time that vary with the windows. The window setting determines the average current.

# RN42/RN42N

**TABLE 1-3: MODULE DIMENSIONS**

Parameter	RN42	RN42N	Units
Size	13.4 x 25.8 x 2.4	13.4 x 20.5 x 2.4	mm
Weight	0.045	0.040	oz.

**TABLE 1-4: RADIO CHARACTERISTICS**

Parameter	Frequency (GHz)	Min.	Typ.	Max.	Bluetooth Specification	Units
Sensitivity at 0.1% BER	2.402	—	-80	-86	≤ -70	dBm
	2.441	—	-80	-86		dBm
	2.480	—	-80	-86		dBm
RF Transmit Power <sup>(1)</sup> RN42	2.402	—	4	—		dBm
	2.441	—	4	—		dBm
	2.480	—	4	—		dBm
RF Transmit Power <sup>(1)</sup> RN42N	2.402	—	4	—		dBm
	2.441	—	4	—		dBm
	2.480	—	4	—		dBm
Initial Carrier Frequency Tolerance	2.402	—	5	75	75	kHz
	2.441	—	5	75		kHz
	2.480	—	5	75		kHz
20-dB Bandwidth for Modulated Carrier	—	—	900	1000	≤ 1000	kHz
Drift (Five Slots Packet)	—	—	15	—	40	kHz
Drift Rate	—	—	13	—	20	kHz
$\Delta f_{1_{avg}}$ Maximum Modulation	2.402	140	165	175	> 140	kHz
	2.441	140	165	175		kHz
	2.480	140	165	175		kHz
$\Delta f_{2_{avg}}$ Minimum Modulation	2.402	140	190	—	115	kHz
	2.441	140	190	—		kHz
	2.480	140	190	—		kHz

**Note 1:** Normal mode

**TABLE 1-5: DIGITAL I/O CHARACTERISTICS**

$3.0\text{ V} \leq \text{VDD} \leq 3.3\text{ V}$	Min.	Typ.	Max.	Units
Input Logic Level Low	-0.4	—	+0.8	V
Input Logic Level High	0.7 VDD	—	VDD + 0.4	V
Output Logic Level Low	—	—	0.2	V
Output Logic Level High	VDD - 0.2	—	—	V
All I/O pins (Except reset) Default to Weak Pull Down	+0.2	+1.0	+5.0	μA

Figure 1-2 and Figure 1-3 show the modules' dimensions.

**FIGURE 1-2: RN42 MODULE DIMENSIONS**

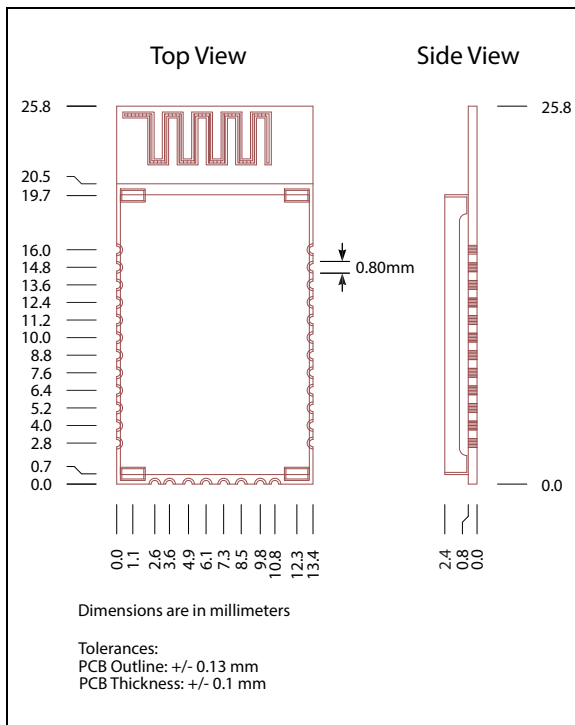
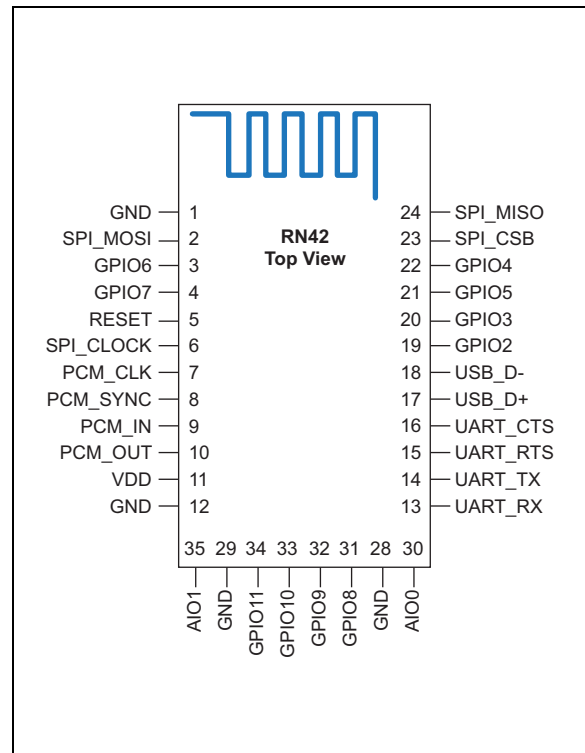
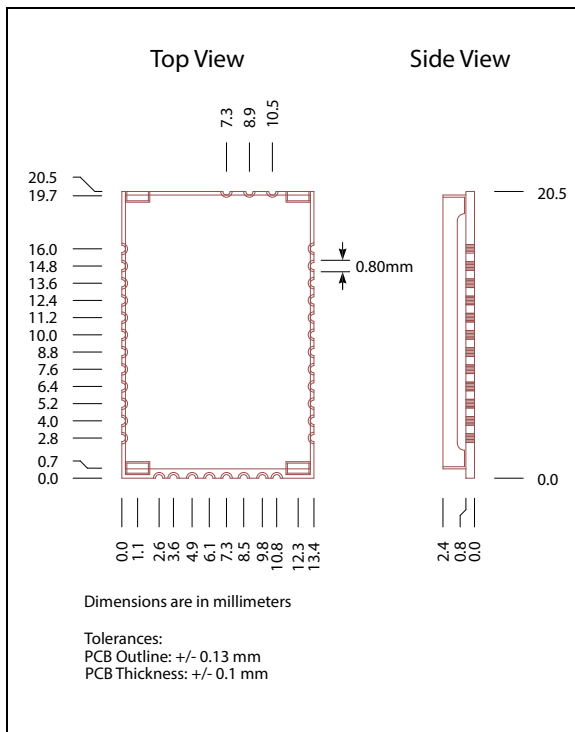

Figure 1-4 and Figure 1-5 show the pinout and Table 1-6 describes the module's pins.

**FIGURE 1-4: RN42 PIN DIAGRAM**



**FIGURE 1-3: RN42N MODULE DIMENSIONS**



**FIGURE 1-5: RN42N PIN DIAGRAM**

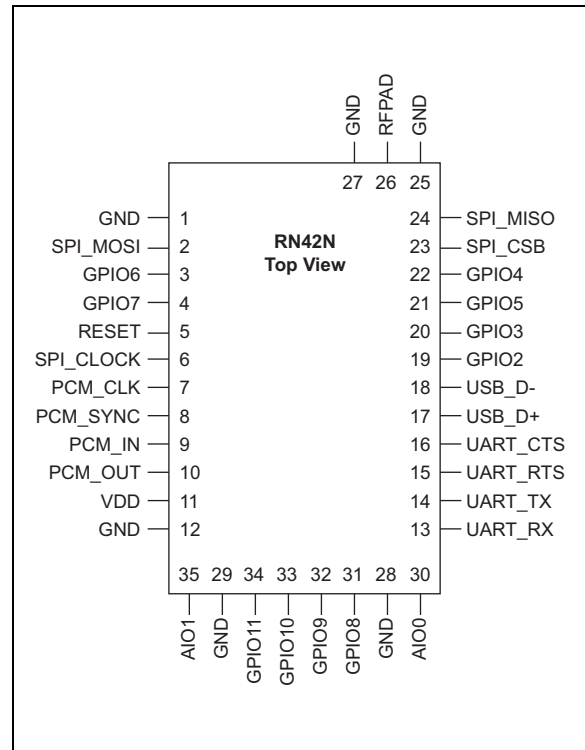

# RN42/RN42N

**TABLE 1-6: PIN DESCRIPTION**

Pin	Symbol	Type	Description
1	GND	Power	Ground reference
2	SPI_MOSI	DI	(Optional) Factory diagnostic, programming and test. See <b>Section 2.8 “SPI Interface”</b> .
3	GPIO6	DI	Set Bluetooth master. If GPIO6 = high, module connects to the stored address. If GPIO3 = high, module enters new Discovery/Pairing mode.
4	GPIO7	DIO	Set baud rate (high = force 9,600, low = 115K or firmware setting)
5	RESET	DI	Active-low Reset
6	SPI_CLK	DI	(Optional) Factory diagnostic and test. See <b>Section 2.8 “SPI Interface”</b> .
7	PCM_CLK	DIO	(Do not connect) PCM interface <sup>(1)</sup>
8	PCM_SYNC	DIO	(Do not connect) PCM interface <sup>(1)</sup>
9	PCM_IN	DI	(Do not connect) PCM interface <sup>(1)</sup>
10	PCM_OUT	DO	(Do not connect) PCM interface <sup>(1)</sup>
11	VDD	Power	Positive Supply
12	GND	Power	Ground reference
13	UART_RX	DI	UART receive input
14	UART_TX	DO	UART transmit output
15	UART_RTS	DO	UART RTS, goes high to disable host transmitter
16	UART_CTS	DI	UART CTS, if set high, it disables transmitter
17	USB_D+	DIO	USB port. 1.5K pullup activated when USB port is ready (~500 ms after reset).
18	USB_D-	DIO	USB port
19	GPIO2	DIO	Status, high when connected, low otherwise. See <b>Section 2.3 “Connection Status”</b> .
20	GPIO3	DI	Auto-discovery mode = high. If GPIO6 = high, module performs device enquiry scan searching for a device with matching class of 0x55AA. If a device is found, the address of the device is stored in the remote address field and auto-connects. If GPIO6 = low, module enters Slave mode with special matching class of 0x55AA and waits for a master to discover it.
21	GPIO5	DIO	Status, toggles based on state, low on connect. See <b>Section 2.3 “Connection Status”</b> .
22	GPIO4	DIO	Set factory defaults. See <b>Section 2.2 “Factory Reset Using GPIO4”</b> .
23	SPI_CS	DI	(Optional) Factory diagnostic and test. See <b>Section 2.8 “SPI Interface”</b> .
24	SPI_MISO	DO	(Optional) Factory diagnostic and test. See <b>Section 2.8 “SPI Interface”</b> .
25	GND	Power	Ground reference (RN42N only)
26	RF_ANT	AIO	Antenna, 50-Ohm impedance (RN42N only)
27	GND	Power	Ground reference (RN42N only)
28	GND	Power	Ground reference
29	GND	Power	Ground reference
30	AIO0	AIO	(Not used) Optional analog input
31	GPIO8	DO	UART TX/RX data activity
32	GPIO9	DIO	I/O
33	GPIO10	DIO	I/O (remote DTR signal)
34	GPIO11	DIO	I/O (remote RTS signal)
35	AIO1	AIO	(Not used) Optional analog input

Pin type abbreviation: **A** = Analog, **D** = Digital, **I** = Input, **O** = Output.

**Note 1:** Pin numbers 7 through 10 are reserved for future use.

## 2.0 APPLICATION INFORMATION

The following sections provide information on designing with the RN42/RN42N module, including radio interference, factory reset, solder reflow profile, connection status, and so on.

### 2.1 Reset Circuit

The RN42/RN42N contains a weak internal pull-up to VCC, and the reset polarity is active low. The module's reset pin has an optional Power-on Reset circuit with a delay, which should only be required if the input power supply has a very slow ramp or tends to bounce or have instability on power-up. Often a microcontroller or embedded CPU I/O is available to generate the reset once power is stable. If not, designers can use one of the many low-cost power supervisor chips available, such as the MCP809 or MCP102/121.

### 2.2 Factory Reset Using GPIO4

It is recommended to connect the GPIO4 pin to a switch, jumper, or resistor so it can be accessed. This pin can be used to reset the module to its factory default settings, which is critical in situations where the module has been misconfigured. To reset the module to the factory defaults, GPIO4 should be high on power-up and then toggle between low and high twice with a 1 second wait between the low-high transitions.

### 2.3 Connection Status

GPIO5 is available to drive an LED, and it blinks at various speeds to indicate status, see [Table 2-1](#). GPIO2 is an output that directly reflects the connection state as shown in [Table 2-2](#).

**TABLE 2-1: GPIO5 STATUS**

GPIO5 Status	Description
Toggle at 1 Hz	The module is discoverable and waiting for a connection.
Toggle at 10 Hz	The module is in command mode.
High	The module is connected to another device over Bluetooth.

**TABLE 2-2: GPIO2 STATUS**

GPIO2 Status	Description
High	The module is connected to another device over Bluetooth.
Low	The module is not connected over Bluetooth.

## 2.4 Module Mounting Details

[Figure 2-1](#) and [Figure 2-2](#) show the recommended PCB footprint for the RN42 and RN42N, respectively. When laying out the carrier board for the RN42 module, the areas under the antenna and shielding connections should not have surface traces, ground planes, or exposed vias.

[Figure 2-3](#) and [Figure 2-4](#) show the recommended mounting details for the RN42 and RN42N, respectively. For optimal radio performance, the RN42 module's antenna end should protrude at least 31 mm beyond any metal enclosure.

[Figure 2-5](#) shows examples of good, bad, and acceptable positioning of the RN42/RN42N on the host PCB.

**FIGURE 2-1: RN42 RECOMMENDED PCB FOOTPRINT**

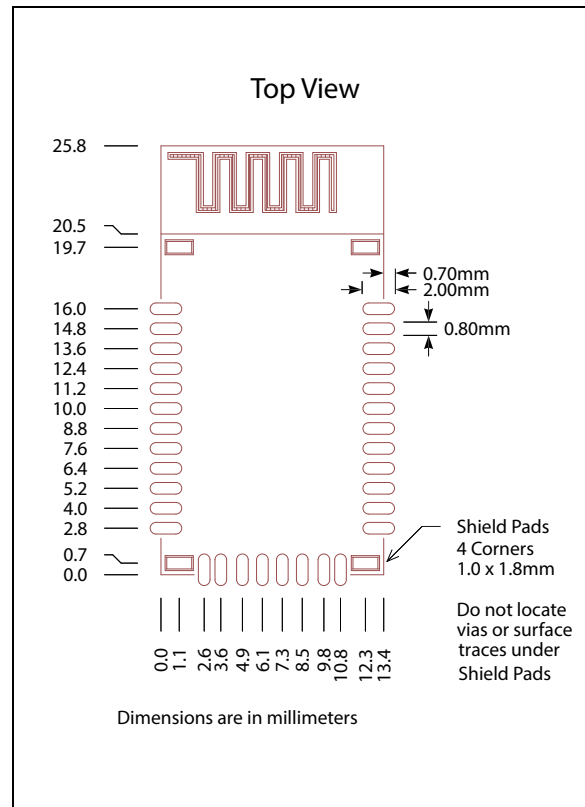

# RN42/RN42N

**FIGURE 2-2: RN42N RECOMMENDED PCB FOOTPRINT**

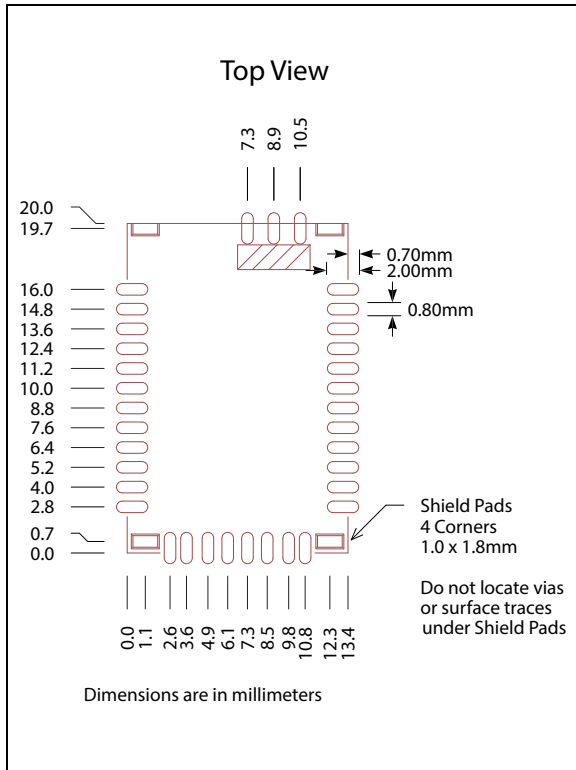

**FIGURE 2-4: RN42N MODULE MOUNTING DETAILS**

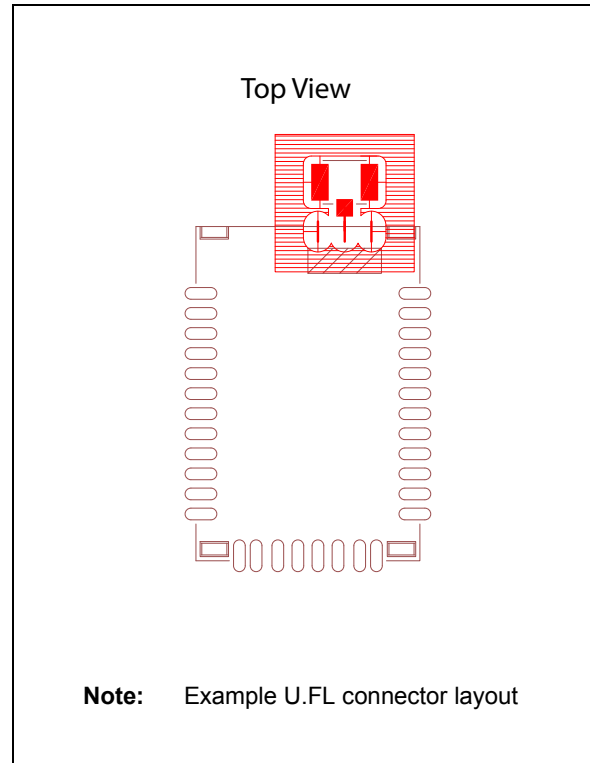

**FIGURE 2-3: RN42 MODULE MOUNTING DETAILS**

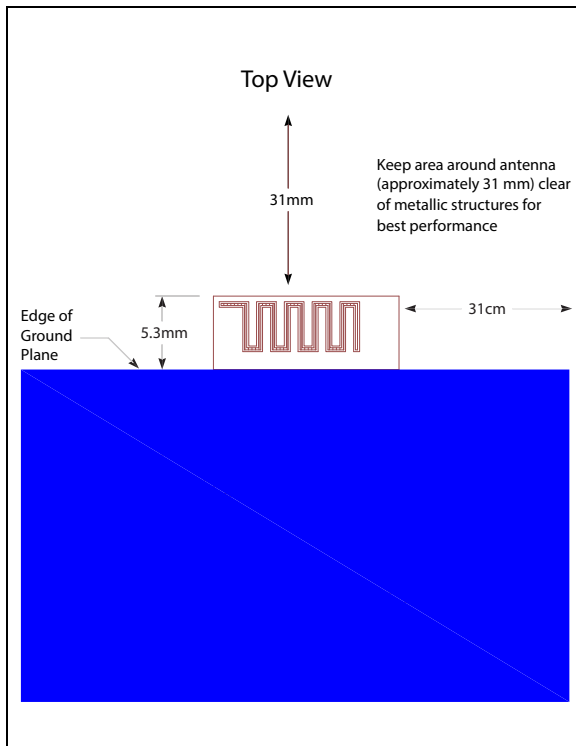

**FIGURE 2-5: RN42 HOST PCB EXAMPLE LAYOUT**

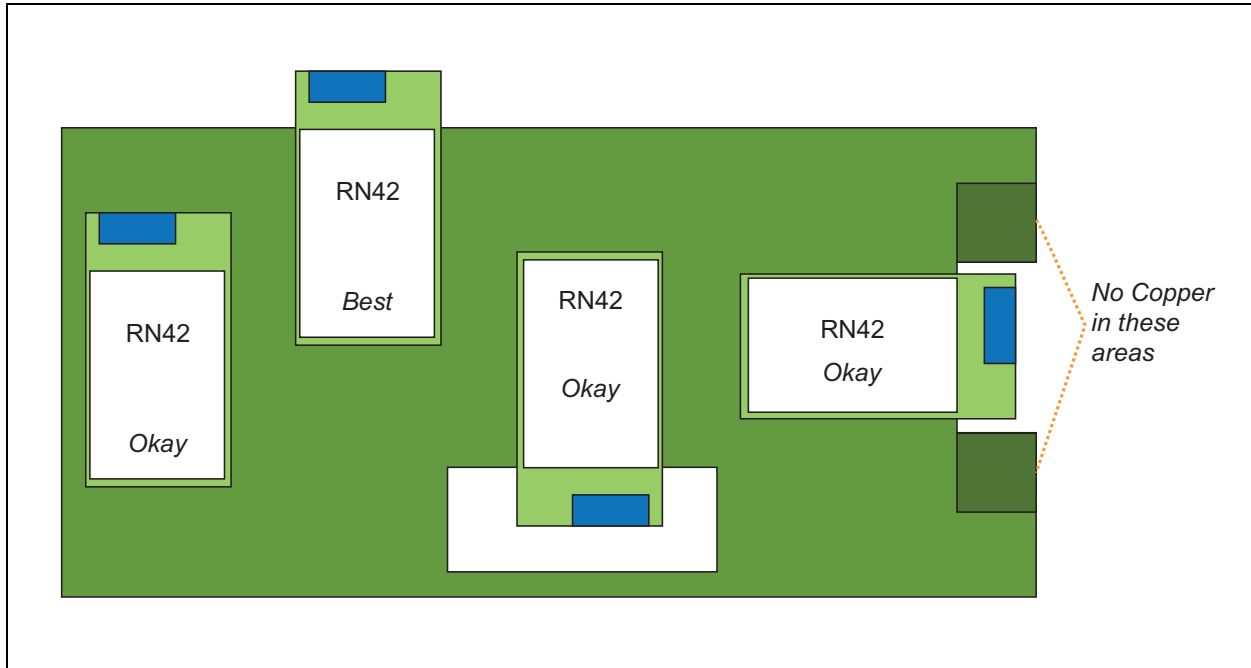

## 2.5 External Antenna Types (RN42N)

The RN42N module's antenna pin (pin 26) provides a 50-ohm impedance to external antennas. Pin 25 can connect directly to a coaxial cable or to an antenna connector such as a U.FL or reverse polarity SMA.

The PCB trace from pin 26 to the coaxial cable or connector should be less than 0.2 inches (5 mm) for minimum loss and the best impedance match. If the PCB trace is longer, it should be a 50-ohm impedance microstrip trace. Connect adjacent ground pins 25 and 27 to a low-impedance ground on the host PCB and the antenna connection. [Figure 2-4](#) gives example host PCB layout to a U.FL connector.

## 2.6 HCI Mode

Microchip offers the Host Controller Interface (HCI) mode in addition to the standard operational mode of its Bluetooth modules (standard mode refers to the on-board stack running on the module).

In HCI mode, the on-board stack is bypassed and the module is put in a state that runs the Bluetooth baseband. The HCI provides a command reference interface to the baseband controller and the link manager, and provides access to the hardware status and control registers. This interface provides a uniform method for accessing the Bluetooth baseband capabilities.

In this mode, the Bluetooth stack is no longer on-board the module. It is offloaded to the interfacing host processor. The Bluetooth module is used as a radio, performing the lower level MAC functionalities, while the application stack runs on the host processor.

Using the module in HCI mode enables designers to implement profiles that are not natively supported on the Bluetooth module.

**Note:** HCI mode is only available by ordering part RN42HCI and RN42HCI for UART interface; or RN42U and RN42U for USB interface.

Microchip offers HCI mode in two hardware interfaces:

- HCI over UART (RN42HCI-I/RM)
- HCI over USB (RN42U-I/RM)

### 2.6.1 HCI OVER UART

In this mode, the hardware interface between the host processor and the Bluetooth module is the UART configured at 115.2Kbps. The UART hardware flow control signals are required between the host processor and the Bluetooth module for the HCI interface to work. Failure to do so can cause the host processor and the Bluetooth module to become out of sync and break the Bluetooth link.

### 2.6.2 HCI OVER USB

In this mode, the hardware interface between the host processor and the Bluetooth module is the USB. In this architecture, the Bluetooth module is the USB slave and the host processor is the USB host.

Using the USB interface offers the advantage of a faster data link between the Bluetooth module and the host processor. With this interface, it is possible to achieve Bluetooth's theoretical maximum throughput of 3 Mbps.

# RN42/RN42N

---

## 2.7 Soldering Recommendations

The RN42/RN42N wireless module was assembled using standard lead-free reflow profile IPC/JEDEC J-STD-020.

The module can be soldered to the host PCB using standard leaded and lead-free solder reflow profiles.

To avoid damaging the module, the following recommendations are given:

- Microchip Technology Application Note, "AN233 Solder Reflow Recommendation" (DS00233) provides solder reflow recommendations
- Do not exceed peak temperature ( $T_p$ ) of 250 C°
- Refer to the Solder Paste data sheet for specific reflow profile recommendations
- Use no-clean flux solder paste
- Do not wash as moisture can be trapped under the shield
- Use only one flow. If the PCB requires multiple flows, apply the module on the final flow.

## 2.8 SPI Interface

The SPI Interface is primarily used for factory programming, test, and diagnostics. Although not required, the SPI interface is useful for restoring a corrupted flash image or enabling test modes required for certification testing.

When module is installed in a final product that requires European type approval, see **Section 3.3 "Europe"**, it is recommended that the SPI interface should be accessible via 6-pin header as shown in [Figure 2-6](#).

**FIGURE 2-6: OPTIONAL SPI INTERFACE**

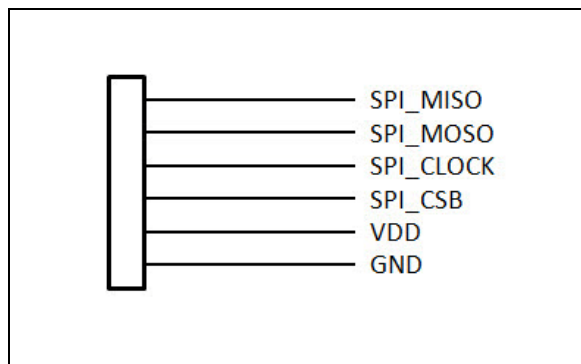

## 2.9 Bluetooth SIG QDID

The RN42 has a QDID registered with the Bluetooth SIG. The manufacturer using the RN42 module in their end product can reference this QDID when filing an EPL (end product listing) to use Bluetooth® brand and logo. For more information, please visit the Bluetooth SIG at [www.bluetooth.org](http://www.bluetooth.org).

QDID: B014867

## 2.10 Application Schematic

Figure 2-7 shows an example application circuit. This schematic is for the RN-42-EK development tool. For details on how to connect RN42/RN42N to a microcontroller, see Section 1.1 “MCU Interface”.

**FIGURE 2-7: EXAMPLE APPLICATION CIRCUIT**

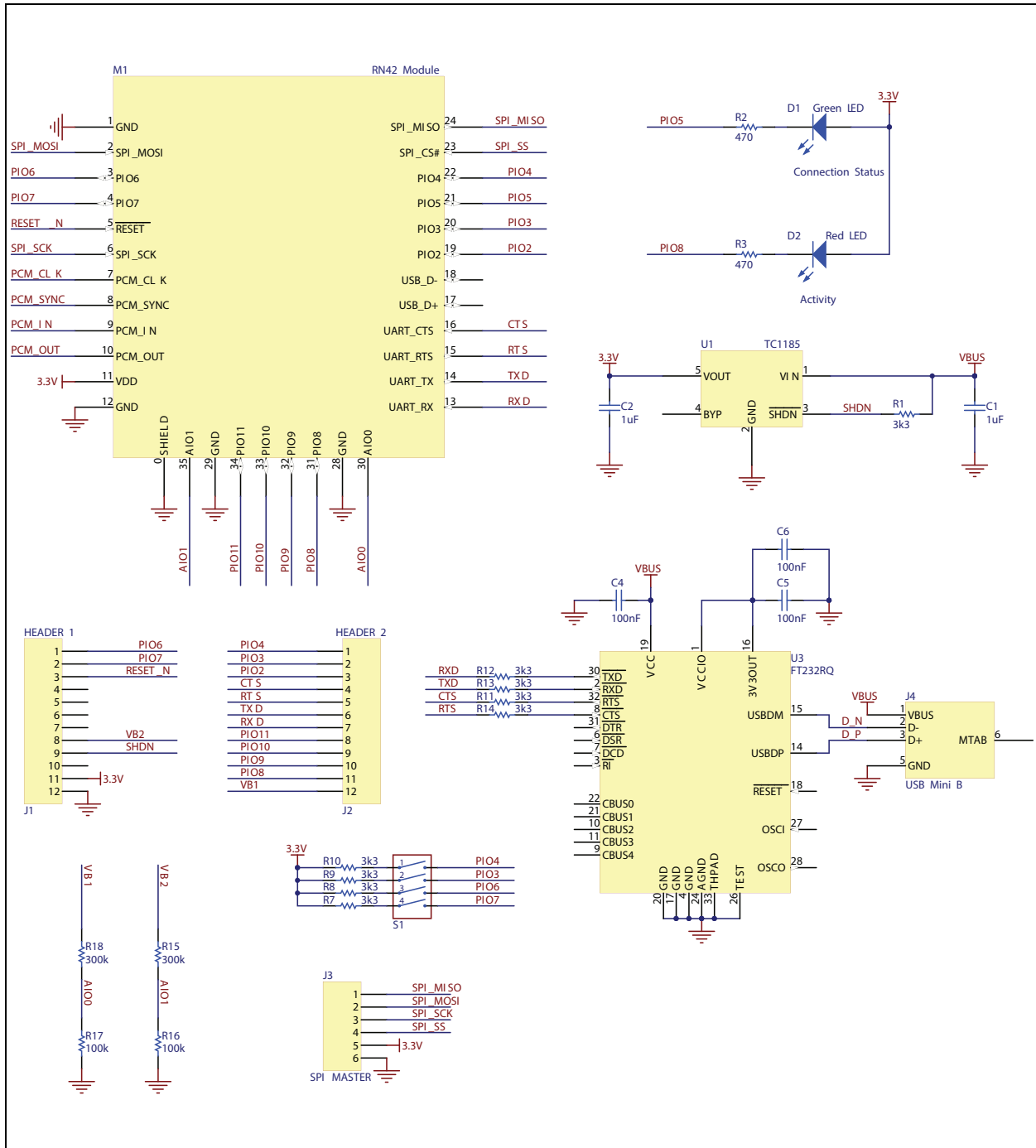

# RN42/RN42N

---

## 3.0 REGULATORY APPROVAL

This section outlines the regulatory information for the RN42 module for the following countries:

- United States
- Canada
- Europe
- Australia
- New Zealand
- Japan
- Korea
- Taiwan

### 3.1 United States

The RN42 module has received Federal Communications Commission (FCC) CFR47 Telecommunications, Part 15 Subpart C “Intentional Radiators” modular approval in accordance with Part 15.212 Modular Transmitter approval. Modular approval allows the end user to integrate the RN42 module into a finished product without obtaining subsequent and separate FCC approvals for intentional radiation, provided no changes or modifications are made to the module circuitry. Changes or modifications could void the user’s authority to operate the equipment. The end user must comply with all of the instructions provided by the Grantee, which indicate installation and/or operating conditions necessary for compliance.

The finished product is required to comply with all applicable FCC equipment authorizations regulations, requirements and equipment functions not associated with the transmitter module portion. For example, compliance must be demonstrated to regulations for other transmitter components within the host product; to requirements for unintentional radiators (Part 15 Subpart B “Unintentional Radiators”), such as digital devices, computer peripherals, radio receivers, etc.; and to additional authorization requirements for the non-transmitter functions on the transmitter module (i.e., Verification, or Declaration of Conformity) (e.g., transmitter modules may also contain digital logic functions) as appropriate.

### 3.1.1 LABELING AND USER INFORMATION REQUIREMENTS

The RN42 module has been labeled with its own FCC ID number, and if the FCC ID is not visible when the module is installed inside another device, then the outside of the finished product into which the module is installed must also display a label referring to the enclosed module. This exterior label can use wording as follows:

Contains Transmitter Module FCC ID: T9J-RN42

*or*

Contains FCC ID: T9J-RN42

This device complies with Part 15 of the FCC Rules. Operation is subject to the following two conditions: (1) this device may not cause harmful interference, and (2) this device must accept any interference received, including interference that may cause undesired operation.

A user’s manual for the product should include the following statement:

This equipment has been tested and found to comply with the limits for a Class B digital device, pursuant to part 15 of the FCC Rules. These limits are designed to provide reasonable protection against harmful interference in a residential installation. This equipment generates, uses and can radiate radio frequency energy, and if not installed and used in accordance with the instructions, may cause harmful interference to radio communications. However, there is no guarantee that interference will not occur in a particular installation. If this equipment does cause harmful interference to radio or television reception, which can be determined by turning the equipment off and on, the user is encouraged to try to correct the interference by one or more of the following measures:

- Reorient or relocate the receiving antenna.
- Increase the separation between the equipment and receiver.
- Connect the equipment into an outlet on a circuit different from that to which the receiver is connected.
- Consult the dealer or an experienced radio/TV technician for help.

Additional information on labeling and user information requirements for Part 15 devices can be found in KDB Publication 784748 available at the FCC Office of Engineering and Technology (OET) Laboratory Division Knowledge Database (KDB) <http://apps.fcc.gov/oetcf/kdb/index.cfm>.

## 3.1.2 RF EXPOSURE

All transmitters regulated by FCC must comply with RF exposure requirements. KDB 447498 General RF Exposure Guidance provides guidance in determining whether proposed or existing transmitting facilities, operations or devices comply with limits for human exposure to Radio Frequency (RF) fields adopted by the Federal Communications Commission (FCC).

From the FCC Grant: Power Output listed is conducted. This module must be installed by the OEM or OEM integrator. Instructions on installation of this module may not be provided to the end user. The antenna used for this transmitter must not be co-located with any other transmitters except in accordance with FCC multi-transmitter product. procedures. Installers must be provided with antenna installation instructions for satisfying RF exposure compliance. Installers and end users must be provided with transmitter operating conditions for satisfying RF exposure compliance.

## 3.1.3 HELPFUL WEB SITES

Federal Communications Commission (FCC): <http://www.fcc.gov>

FCC Office of Engineering and Technology (OET) Laboratory Division Knowledge Database (KDB): <http://apps.fcc.gov/oetcf/kdb/index.cfm>

## 3.2 Canada

The RN42 module has been certified for use in Canada under Industry Canada (IC) Radio Standards Specification (RSS) RSS-210 and RSSGen. Modular approval permits the installation of a module in a host device without the need to recertify the device.

### 3.2.1 LABELING AND USER INFORMATION REQUIREMENTS

Labeling Requirements for the Host Device (from Section 3.2.1, RSS-Gen, Issue 3, December 2010): The host device shall be properly labeled to identify the module within the host device.

The Industry Canada certification label of a module shall be clearly visible at all times when installed in the host device, otherwise the host device must be labeled to display the Industry Canada certification number of the module, preceded by the words "Contains transmitter module", or the word "Contains", or similar wording expressing the same meaning, as follows:

**RN42:**  
Contains transmitter module IC: 6514A-RN42

User Manual Notice for License-Exempt Radio Apparatus (from Section 7.1.3 RSS-Gen, Issue 3, December 2010): User manuals for license-exempt radio apparatus shall contain the following or equivalent notice in a conspicuous location in the user manual or alternatively on the device or both:

This device complies with Industry Canada license-exempt RSS standard(s). Operation is subject to the following two conditions: (1) this device may not cause interference, and (2) this device must accept any interference, including interference that may cause undesired operation of the device.

Le présent appareil est conforme aux CNR d'Industrie Canada applicables aux appareils radio exempts de licence. L'exploitation est autorisée aux deux conditions suivantes: (1) l'appareil ne doit pas produire de brouillage, et (2) l'utilisateur de l'appareil doit accepter tout brouillage radioélectrique subi, même si le brouillage est susceptible d'en compromettre le fonctionnement.

Transmitter Antenna (from Section 7.1.2 RSS-Gen, Issue 3, December 2010): User manuals for transmitters shall display the following notice in a conspicuous location:

Under Industry Canada regulations, this radio transmitter may only operate using an antenna of a type and maximum (or lesser) gain approved for the transmitter by Industry Canada. To reduce potential radio interference to other users, the antenna type and its gain should be so chosen that the equivalent isotropically radiated power (e.i.r.p.) is not more than that necessary for successful communication.

Conformément à la réglementation d'Industrie Canada, le présent émetteur radio peut fonctionner avec une antenne d'un type et d'un gain maximal (ou inférieur) approuvé pour l'émetteur par Industrie Canada. Dans le but de réduire les risques de brouillage radioélectrique à l'intention des autres utilisateurs, il faut choisir le type d'antenne et son gain de sorte que la puissance isotrope rayonnée équivalente (p.i.r.e.) ne dépasse pas l'intensité nécessaire à l'établissement d'une communication satisfaisante.

The above notice may be affixed to the device instead of displayed in the user manual.

## 3.2.2 RF EXPOSURE

All transmitters regulated by IC must comply with RF exposure requirements listed in RSS-102 - Radio Frequency (RF) Exposure Compliance of Radiocommunication Apparatus (All Frequency Bands).

## 3.2.3 HELPFUL WEB SITES

Industry Canada: <http://www.ic.gc.ca>

# RN42/RN42N

---

## 3.3 Europe

The RN42 module is an R&TTE Directive assessed radio module that is CE marked and has been manufactured and tested with the intention of being integrated into a final product.

The RN42 module has been tested to R&TTE Directive 1999/5/EC Essential Requirements for Health and Safety (Article (3.1(a)), Electromagnetic Compatibility (EMC) (Article 3.1(b)), and Radio (Article 3.2) and are summarized in Table 3-1: European Compliance Testing. A Notified Body Opinion has also been issued. All test reports are available on the RN42 product web page at <http://www.microchip.com>.

The R&TTE Compliance Association provides guidance on modular devices in document **Technical Guidance Note 01** available at [http://www.rteca.com/html/download\\_area.htm](http://www.rteca.com/html/download_area.htm).

**Note:** To maintain conformance to the testing listed in Table 3-1, the module shall be installed in accordance with the installation instructions in this data sheet and shall not be modified.

When integrating a radio module into a completed product the integrator becomes the manufacturer of the final product and is therefore responsible for demonstrating compliance of the final product with the essential requirements of the R&TTE Directive.

### 3.3.1 LABELING AND USER INFORMATION REQUIREMENTS

The label on the final product which contains the RN42 module must follow CE marking requirements. The “*R&TTE Compliance Association Technical Guidance Note 01*” provides guidance on final product CE marking.

### 3.3.2 ANTENNA REQUIREMENTS

From R&TTE Compliance Association document **Technical Guidance Note 01**:

Provided the integrator installing an assessed radio module with an integral or specific antenna and installed in conformance with the radio module manufacturer’s installation instructions requires no further evaluation under Article 3.2 of the R&TTE Directive and does not require further involvement of an R&TTE Directive Notified Body for the final product. [Section 2.2.4]

### 3.3.3 HELPFUL WEB SITES

A document that can be used as a starting point in understanding the use of Short Range Devices (SRD) in Europe is the European Radio Communications Committee (ERC) Recommendation 70-03 E, which can be downloaded from the European Radio Communications Office (ERO) at: <http://www.ero.dk>.

Additional helpful web sites are:

- Radio and Telecommunications Terminal Equipment (R&TTE):  
[http://ec.europa.eu/enterprise/rte/index\\_en.htm](http://ec.europa.eu/enterprise/rte/index_en.htm)
- European Conference of Postal and Telecommunications Administrations (CEPT):  
<http://www.cept.org>
- European Telecommunications Standards Institute (ETSI):  
<http://www.etsi.org>
- European Radio Communications Office (ERO):  
<http://www.ero.dk>
- The Radio and Telecommunications Terminal Equipment Compliance Association (R&TTE CA):  
<http://www.rteca.com>

**TABLE 3-1: RN42 EUROPEAN COMPLIANCE TESTING**

Certification	Standards	Article	Laboratory	Report Number	Date
Safety	EN 60950-1:2006+A11:2009+A1:2010+A12:2011	[3.1(a)]	Worldwide Testing Services (Taiwan) Co., Ltd.	W6M21402-13966-L	2014-03-24
Health	EN 62479:2010			W6M21402-13966-62479	2014-03-13
EMC	EN 301 489-1 V1.9.2 (2011-09)	[3.1(b)]		W6M21402-13966-E-16	2014-03-13
	EN 301 489-17 V2.2.1 (2012-09)				
Radio	EN 300 328 V1.8.1 (2012-06)	(3.2)		W6M21402-13966-T-45	2014-03-13
Notified Body Opinion	<b>CE0681</b>	—	Eurofins Product Service GmbH	U9M-1404-3736-C-V01	2014-04-15

### 3.4 Australia

The Australia radio regulations do not provide a modular approval policy similar to the United States (FCC) and Canada (IC). However, RN42 module RF transmitter test reports can be used in part to demonstrate compliance in accordance with ACMA Radio communications “Short Range Devices” Standard 2004 (The Short Range Devices standard calls up the AS/NZS 4268:2008 industry standard). The RN42/RN42N module test reports can be used as part of the product certification and compliance folder. For more information on the RF transmitter test reports, contact Microchip Technology Australia sales office.

To meet overall Australian final product compliance, the developer must construct a compliance folder containing all relevant compliance test reports e.g. RF, EMC, electrical safety and DoC (Declaration of Conformity) etc. It is the responsibility of the integrator to know what is required in the compliance folder for ACMA compliance. All test reports are available on the RN42 product web page at <http://www.microchip.com>. For more information on Australia compliance, refer to the Australian Communications and Media Authority web site <http://www.acma.gov.au>.

#### 3.4.1 HELPFUL WEB SITES

The Australian Communications and Media Authority: <http://www.acma.gov.au>.

### 3.5 New Zealand

The New Zealand radio regulations do not provide a modular approval policy similar to the United States (FCC) and Canada (IC). However, RN42 module RF transmitter test reports can be used in part to demonstrate compliance against the New Zealand “General User Radio License for Short Range Devices”. New Zealand Radio communications (Radio Standards) Notice 2010 calls up the AS / NZS 4268:2008 industry standard. The RN42 module test reports can be used as part of the product certification and compliance folder. All test reports are available on the RN42 product web page at <http://www.microchip.com>. For more information on the RF transmitter test reports, contact Microchip Technology sales office.

Information on the New Zealand short range devices license can be found in the following web links:

- <http://www.rsm.govt.nz/cms/licensees/types-of-licence/general-user-licences/short-range-devices>
- <http://www.rsm.govt.nz/cms/policy-and-planning/spectrum-policy-overview/legislation/gazette-notices/product-compliance/radiocommunications-radiostandards-notice-2010>.

To meet overall New Zealand final product compliance, the developer must construct a compliance folder containing all relevant compliance test reports e.g. RF, EMC, electrical safety and DoC (Declaration of Conformity) etc. It is the responsibility of the developer to know what is required in the compliance folder for New Zealand Radio communications. For more information on New Zealand compliance, refer to the web site <http://www.rsm.govt.nz>.

#### 3.5.1 HELPFUL WEB SITES

Radio Spectrum Ministry of Economic Development: <http://www.rsm.govt.nz>.

# RN42/RN42N

## 3.6 Japan

The RN42 module has received type certification and is labeled with its own technical conformity mark and certification number as required to conform to the technical standards regulated by the Ministry of Internal Affairs and Communications (MIC) of Japan pursuant to the Radio Act of Japan.

Integration of this module into a final product does not require additional radio certification provided installation instructions are followed and no modifications of the module are allowed. Additional testing may be required:

- If the host product is subject to electrical appliance safety (for example, powered from an AC mains), the host product may require Product Safety Electrical Appliance and Material (PSE) testing. The integrator should contact their conformance laboratory to determine if this testing is required.
- There is an voluntary Electromagnetic Compatibility (EMC) test for the host product administered by VCCI: [http://www.vcci.jp/vcci\\_e/index.html](http://www.vcci.jp/vcci_e/index.html).

### 3.6.1 LABELING AND USER INFORMATION REQUIREMENTS

The label on the final product which contains the RN42 module must follow Japan marking requirements. The integrator of the module should refer to the labeling requirements for Japan available at the Ministry of Internal Affairs and Communications (MIC) website.

The RN42 module is labeled with its own technical conformity mark and certification number. The final product in which this module is being used must have a label referring to the type certified module inside:

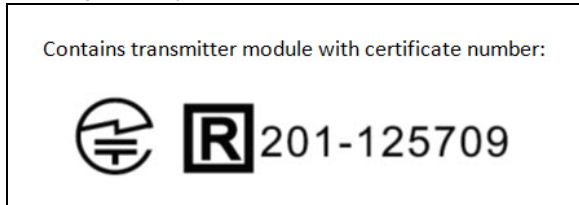

### 3.6.2 HELPFUL WEB SITES

Ministry of Internal Affairs and Communications (MIC):

<http://www.tele.soumu.go.jp/e/index.htm>

Association of Radio Industries and Businesses (ARIB): <http://www.arib.or.jp/english>

## 3.7 Korea

The RN42 module has received certification of conformity in accordance with the Radio Waves Act. Integration of this module into a final product does not require additional radio certification provided installation instructions are followed and no modifications of the module are allowed.

### 3.7.1 LABELING AND USER INFORMATION REQUIREMENTS

The label on the final product which contains the RN42 module must follow KC marking requirements. The integrator of the module should refer to the labeling requirements for Korea available on the Korea Communications Commission (KCC) website.

The RN42 module is labeled with its own KC mark. The final product requires the KC mark and certificate number of the module:

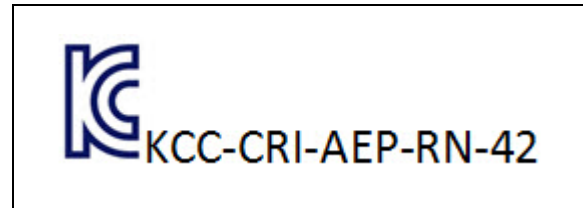

### 3.7.2 HELPFUL WEB SITES

Korea Communications Commission (KCC):

<http://www.kcc.go.kr>

National Radio Research Agency (RRA):

<http://rra.go.kr>

## 3.8 Taiwan

The RN42 module has received compliance approval in accordance with the Telecommunications Act. Customers seeking to use the compliance approval in their product should contact Microchip Technology sales or distribution partners to obtain a Letter of Authority.

Integration of this module into a final product does not require additional radio certification provided installation instructions are followed and no modifications of the module are allowed.

### 3.8.1 LABELING AND USER INFORMATION REQUIREMENTS

The RN42 module is labeled with its own NCC mark and certificate number as below:



The user's manual should contain below warning (for RF device) in traditional Chinese:

注意！

依據 低功率電波輻射性電機管理辦法

第十二條 經型式認證合格之低功率射頻電機，非經許可，公司、商號或使用者均不得擅自變更頻率、加大功率或變更原設計之特性及功能。

第十四條 低功率射頻電機之使用不得影響飛航安全及干擾合法通信；經發現有干擾現象時，應立即停用，並改善至無干擾時方得繼續使用。

前項合法通信，指依電信規定作業之無線電信。

低功率射頻電機須忍受合法通信或工業、科學及醫療用電波輻射性電機設備之干擾。

### 3.8.2 HELPFUL WEB SITES

National Communications Commission (NCC):

<http://www.ncc.gov.tw>

# RN42/RN42N

## 4.0 ORDERING INFORMATION

Table 4-1 provides ordering information for the RN42 module.

**TABLE 4-1: ORDERING INFORMATION<sup>(1)</sup>**

Part Number <sup>(1)</sup>	Firmware <sup>(2)</sup>	Description
RN42-I/RM	6.15	Class 2, 2.1+EDR, SPP profile
RN42-I/RM615	6.15	Class 2, 2.1+EDR, SPP profile
RN42-I/RM477	4.77	Class 2, 2.1+EDR, SPP profile
RN42HCI-I/RM	N/A	Class 2, 2.0+EDR, HCI over UART
RN42HID-I/RM	6.11	Class 2, 2.1+EDR, HID and SPP profiles
RN42U-I/RM	N/A	Class 2, 2.0+EDR, HCI over USB
RN42APL-I/RM	5.45	Class 2, 2.1+EDR, SPP and MFi profiles
RN42APL-I/RM545	5.45	Class 2, 2.1+EDR, SPP and MFi profiles
RN42APL-I/RM543	5.43	Class 2, 2.1+EDR, SPP and MFi profiles
RN42N-I/RM	6.15	Class 2, 2.1+EDR, SPP profile
RN42NHCI-I/RM	N/A	Class 2, 2.0+EDR, HCI over UART
RN42NHID-I/RM	6.11	Class 2, 2.1+EDR, HID and SPP profiles
RN42NU-I/RM	N/A	Class 2, 2.0+EDR, HCI over USB
RN42NAPL-I/RM	5.45	Class 2, 2.1+EDR, SPP and MFi profiles

**Note 1:** For other configurations, contact Microchip directly.

- 2:** It is highly recommended that customers order part numbers by specific firmware version when available to ensure consistent receipt of their designed-in firmware version. Information on firmware versions can be found on the RN42/RN42N product web page and the *Bluetooth Data Module Command Reference and Advanced Information User's Guide*.

Go to <http://www.microchip.com> for current pricing and a list of distributors carrying Microchip products.

## APPENDIX A: REVISION HISTORY

### Revision A (January 2015)

This is the initial released version of the document in the Microchip format. This replaces Roving Networks RN42/RN42N Data Sheet.

# RN42/RN42N

---

NOTES:

## THE MICROCHIP WEB SITE

Microchip provides online support via our WWW site at [www.microchip.com](http://www.microchip.com). This web site is used as a means to make files and information easily available to customers. Accessible by using your favorite Internet browser, the web site contains the following information:

- **Product Support** – Data sheets and errata, application notes and sample programs, design resources, user's guides and hardware support documents, latest software releases and archived software
- **General Technical Support** – Frequently Asked Questions (FAQ), technical support requests, online discussion groups, Microchip consultant program member listing
- **Business of Microchip** – Product selector and ordering guides, latest Microchip press releases, listing of seminars and events, listings of Microchip sales offices, distributors and factory representatives

## CUSTOMER CHANGE NOTIFICATION SERVICE

Microchip's customer notification service helps keep customers current on Microchip products. Subscribers will receive e-mail notification whenever there are changes, updates, revisions or errata related to a specified product family or development tool of interest.

To register, access the Microchip web site at [www.microchip.com](http://www.microchip.com). Under "Support", click on "Customer Change Notification" and follow the registration instructions.

## CUSTOMER SUPPORT

Users of Microchip products can receive assistance through several channels:

- Distributor or Representative
- Local Sales Office
- Field Application Engineer (FAE)
- Technical Support

Customers should contact their distributor, representative or Field Application Engineer (FAE) for support. Local sales offices are also available to help customers. A listing of sales offices and locations is included in the back of this document.

**Technical support is available through the web site at: <http://microchip.com/support>**

# RN42/RN42N

---

NOTES:

## PRODUCT IDENTIFICATION SYSTEM

To order or obtain information, e.g., on pricing or delivery, refer to the factory or the listed sales office.

<u>PART NO.</u>	↓	<u>RM</u>	<u>XXX</u>	
Device	Temperature Range	Package	Firmware Revision Number	
<p><b>Device:</b></p> <p>RN42 : UART, Integral Antenna            RN42N : UART, External Antenna            RN42HCI: UART, HCI firmware, Integral Antenna            RN42U : USB, Integral Antenna            RN42APL: UART, MFi firmware</p> <p><b>Temperature Range:</b> I = -40°C to +85°C</p> <p><b>Package: *</b> RM = Radio Module</p> <p style="text-align: center;">*All package offerings are Pb (Lead) Free</p>				<p><b>Examples:</b></p> <p>a) RN42-I/RM: Integral Antenna, Firmware version 6.15</p> <p>b) RN42-I/RM615: Integral Antenna, Firmware version 6.15</p> <p>c) RN42APL-I/RM: Integral Antenna, Firmware version 5.45, SPP and MFi firmware</p> <p>d) RN42N-I/RM: External Antenna, Firmware version 6.15</p>

# RN42/RN42N

---

NOTES:

---

**Note the following details of the code protection feature on Microchip devices:**

- Microchip products meet the specification contained in their particular Microchip Data Sheet.
- Microchip believes that its family of products is one of the most secure families of its kind on the market today, when used in the intended manner and under normal conditions.
- There are dishonest and possibly illegal methods used to breach the code protection feature. All of these methods, to our knowledge, require using the Microchip products in a manner outside the operating specifications contained in Microchip's Data Sheets. Most likely, the person doing so is engaged in theft of intellectual property.
- Microchip is willing to work with the customer who is concerned about the integrity of their code.
- Neither Microchip nor any other semiconductor manufacturer can guarantee the security of their code. Code protection does not mean that we are guaranteeing the product as "unbreakable."

Code protection is constantly evolving. We at Microchip are committed to continuously improving the code protection features of our products. Attempts to break Microchip's code protection feature may be a violation of the Digital Millennium Copyright Act. If such acts allow unauthorized access to your software or other copyrighted work, you may have a right to sue for relief under that Act.

---

Information contained in this publication regarding device applications and the like is provided only for your convenience and may be superseded by updates. It is your responsibility to ensure that your application meets with your specifications. MICROCHIP MAKES NO REPRESENTATIONS OR WARRANTIES OF ANY KIND WHETHER EXPRESS OR IMPLIED, WRITTEN OR ORAL, STATUTORY OR OTHERWISE, RELATED TO THE INFORMATION, INCLUDING BUT NOT LIMITED TO ITS CONDITION, QUALITY, PERFORMANCE, MERCHANTABILITY OR FITNESS FOR PURPOSE. Microchip disclaims all liability arising from this information and its use. Use of Microchip devices in life support and/or safety applications is entirely at the buyer's risk, and the buyer agrees to defend, indemnify and hold harmless Microchip from any and all damages, claims, suits, or expenses resulting from such use. No licenses are conveyed, implicitly or otherwise, under any Microchip intellectual property rights.

#### **Trademarks**

The Microchip name and logo, the Microchip logo, dsPIC, FlashFlex, flexPWR, JukeBlox, KEELOQ, KEELOQ logo, Kleer, LANCheck, MediaLB, MOST, MOST logo, MPLAB, OptoLyzer, PIC, PICSTART, PIC<sup>32</sup> logo, RightTouch, SpyNIC, SST, SST Logo, SuperFlash and UNI/O are registered trademarks of Microchip Technology Incorporated in the U.S.A. and other countries.

The Embedded Control Solutions Company and mTouch are registered trademarks of Microchip Technology Incorporated in the U.S.A.

Analog-for-the-Digital Age, BodyCom, chipKIT, chipKIT logo, CodeGuard, dsPICDEM, dsPICDEM.net, ECAN, In-Circuit Serial Programming, ICSP, Inter-Chip Connectivity, KleerNet, KleerNet logo, MiWi, MPASM, MPF, MPLAB Certified logo, MPLIB, MPLINK, MultiTRAK, NetDetach, Omniscient Code Generation, PICDEM, PICDEM.net, PICKit, PICTail, RightTouch logo, REAL ICE, SQL, Serial Quad I/O, Total Endurance, TSHARC, USBCheck, VariSense, ViewSpan, WiperLock, Wireless DNA, and ZENA are trademarks of Microchip Technology Incorporated in the U.S.A. and other countries.

SQTP is a service mark of Microchip Technology Incorporated in the U.S.A.

Silicon Storage Technology is a registered trademark of Microchip Technology Inc. in other countries.

GestIC is a registered trademarks of Microchip Technology Germany II GmbH & Co. KG, a subsidiary of Microchip Technology Inc., in other countries.

All other trademarks mentioned herein are property of their respective companies.

© 2015, Microchip Technology Incorporated, Printed in the U.S.A., All Rights Reserved.

ISBN: 978-1-63276-903-9

**QUALITY MANAGEMENT SYSTEM  
CERTIFIED BY DNV  
= ISO/TS 16949 =**

*Microchip received ISO/TS-16949:2009 certification for its worldwide headquarters, design and wafer fabrication facilities in Chandler and Tempe, Arizona; Gresham, Oregon and design centers in California and India. The Company's quality system processes and procedures are for its PIC® MCUs and dsPIC® DSCs, KEELOQ® code hopping devices, Serial EEPROMs, microperipherals, nonvolatile memory and analog products. In addition, Microchip's quality system for the design and manufacture of development systems is ISO 9001:2000 certified.*



# MICROCHIP

## Worldwide Sales and Service

### AMERICAS

**Corporate Office**  
2355 West Chandler Blvd.  
Chandler, AZ 85224-6199  
Tel: 480-792-7200  
Fax: 480-792-7277  
Technical Support:  
<http://www.microchip.com/support>  
Web Address:  
[www.microchip.com](http://www.microchip.com)

**Atlanta**  
Duluth, GA  
Tel: 678-957-9614  
Fax: 678-957-1455

**Austin, TX**  
Tel: 512-257-3370

**Boston**  
Westborough, MA  
Tel: 774-760-0087  
Fax: 774-760-0088

**Chicago**  
Itasca, IL  
Tel: 630-285-0071  
Fax: 630-285-0075

**Cleveland**  
Independence, OH  
Tel: 216-447-0464  
Fax: 216-447-0643

**Dallas**  
Addison, TX  
Tel: 972-818-7423  
Fax: 972-818-2924

**Detroit**  
Novi, MI  
Tel: 248-848-4000

**Houston, TX**  
Tel: 281-894-5983

**Indianapolis**  
Noblesville, IN  
Tel: 317-773-8323  
Fax: 317-773-5453

**Los Angeles**  
Mission Viejo, CA  
Tel: 949-462-9523  
Fax: 949-462-9608

**New York, NY**  
Tel: 631-435-6000

**San Jose, CA**  
Tel: 408-735-9110

**Canada - Toronto**  
Tel: 905-673-0699  
Fax: 905-673-6509

### ASIA/PACIFIC

**Asia Pacific Office**  
Suites 3707-14, 37th Floor  
Tower 6, The Gateway  
Harbour City, Kowloon  
Hong Kong  
Tel: 852-2943-5100  
Fax: 852-2401-3431

**Australia - Sydney**  
Tel: 61-2-9868-6733  
Fax: 61-2-9868-6755

**China - Beijing**  
Tel: 86-10-8569-7000  
Fax: 86-10-8528-2104

**China - Chengdu**  
Tel: 86-28-8665-5511  
Fax: 86-28-8665-7889

**China - Chongqing**  
Tel: 86-23-8980-9588  
Fax: 86-23-8980-9500

**China - Hangzhou**  
Tel: 86-571-8792-8115  
Fax: 86-571-8792-8116

**China - Hong Kong SAR**  
Tel: 852-2943-5100  
Fax: 852-2401-3431

**China - Nanjing**  
Tel: 86-25-8473-2460  
Fax: 86-25-8473-2470

**China - Qingdao**  
Tel: 86-532-8502-7355  
Fax: 86-532-8502-7205

**China - Shanghai**  
Tel: 86-21-5407-5533  
Fax: 86-21-5407-5066

**China - Shenyang**  
Tel: 86-24-2334-2829  
Fax: 86-24-2334-2393

**China - Shenzhen**  
Tel: 86-755-8864-2200  
Fax: 86-755-8203-1760

**China - Wuhan**  
Tel: 86-27-5980-5300  
Fax: 86-27-5980-5118

**China - Xian**  
Tel: 86-29-8833-7252  
Fax: 86-29-8833-7256

**China - Xiamen**  
Tel: 86-592-2388138  
Fax: 86-592-2388130

**China - Zhuhai**  
Tel: 86-756-3210040  
Fax: 86-756-3210049

### ASIA/PACIFIC

**India - Bangalore**  
Tel: 91-80-3090-4444  
Fax: 91-80-3090-4123

**India - New Delhi**  
Tel: 91-11-4160-8631  
Fax: 91-11-4160-8632

**India - Pune**  
Tel: 91-20-3019-1500

**Japan - Osaka**  
Tel: 81-6-6152-7160  
Fax: 81-6-6152-9310

**Japan - Tokyo**  
Tel: 81-3-6880-3770  
Fax: 81-3-6880-3771

**Korea - Daegu**  
Tel: 82-53-744-4301  
Fax: 82-53-744-4302

**Korea - Seoul**  
Tel: 82-2-554-7200  
Fax: 82-2-558-5932 or  
82-2-558-5934

**Malaysia - Kuala Lumpur**  
Tel: 60-3-6201-9857  
Fax: 60-3-6201-9859

**Malaysia - Penang**  
Tel: 60-4-227-8870  
Fax: 60-4-227-4068

**Philippines - Manila**  
Tel: 63-2-634-9065  
Fax: 63-2-634-9069

**Singapore**  
Tel: 65-6334-8870  
Fax: 65-6334-8850

**Taiwan - Hsin Chu**  
Tel: 886-3-5778-366  
Fax: 886-3-5770-955

**Taiwan - Kaohsiung**  
Tel: 886-7-213-7830

**Taiwan - Taipei**  
Tel: 886-2-2508-8600  
Fax: 886-2-2508-0102

**Thailand - Bangkok**  
Tel: 66-2-694-1351  
Fax: 66-2-694-1350

### EUROPE

**Austria - Wels**  
Tel: 43-7242-2244-39  
Fax: 43-7242-2244-393

**Denmark - Copenhagen**  
Tel: 45-4450-2828  
Fax: 45-4485-2829

**France - Paris**  
Tel: 33-1-69-53-63-20  
Fax: 33-1-69-30-90-79

**Germany - Dusseldorf**  
Tel: 49-2129-3766400

**Germany - Munich**  
Tel: 49-89-627-144-0  
Fax: 49-89-627-144-44

**Germany - Pforzheim**  
Tel: 49-7231-424750

**Italy - Milan**  
Tel: 39-0331-742611  
Fax: 39-0331-466781

**Italy - Venice**  
Tel: 39-049-7625286

**Netherlands - Drunen**  
Tel: 31-416-690399  
Fax: 31-416-690340

**Poland - Warsaw**  
Tel: 48-22-3325737

**Spain - Madrid**  
Tel: 34-91-708-08-90  
Fax: 34-91-708-08-91

**Sweden - Stockholm**  
Tel: 46-8-5090-4654

**UK - Wokingham**  
Tel: 44-118-921-5800  
Fax: 44-118-921-5820

03/25/14

## Looking for pricing, stock, or lifecycle information?

Click below to explore more details on WIN SOURCE:

- ⊖ [View RN42-I/RM on WIN SOURCE](#)
- ⊖ [Microchip Technology Information](#)

## Optimize Your Supply Chain with WIN SOURCE Solutions

- ✓ Global Sourcing Solution
- ✓ Obsolete Management
- ✓ Cost Control Management
- ✓ Shortage Management
- ✓ Alternative Solution
- ✓ Excess Inventory Management