



**THE DATASHEET OF  
LMZ31707RVQR**



# LMZ31707 7-A Power Module with 2.95-V to 17-V Input and Current Sharing in QFN Package

## 1 Features

- Complete integrated power solution allows small footprint, low-profile design
- 10-mm × 10-mm × 4.3-mm package
  - Pin compatible with LMZ31710 and LMZ31704
- Efficiencies up to 95%
- Eco-mode™ / light load efficiency (LLE)
- Wide-output voltage adjust  
0.6 V to 5.5 V, with 1% reference accuracy
- Supports parallel operation for higher current
- Optional split power rail allows input voltage down to 2.95 V
- Adjustable switching frequency (200 kHz to 1.2 MHz)
- Synchronizes to an external clock
- Provides 180° out-of-phase clock signal
- Adjustable slow start
- Output voltage sequencing / tracking
- Power good output
- Programmable undervoltage lockout (UVLO)
- Overcurrent and overtemperature protection
- Pre-Bias output start-up
- Operating temperature range: –40°C to +85°C
- Enhanced thermal performance: 13.3°C/W
  - Integrated shielded inductor
- Create a custom design using the LMZ31707 with the [WEBENCH® Power Designer](#)

## 2 Applications

- [Broadband and communications infrastructure](#)
- [Automated test and medical equipment](#)
- [Compact PCI / PCI express / PXI express](#)
- [DSP and FPGA point-of-load applications](#)

## 3 Description

The LMZ31707 SIMPLE SWITCHER® power module is an easy-to-use integrated power solution that combines a 7-A DC-DC converter with power MOSFETs, a shielded inductor, and passives into a low profile, QFN package. This total power solution allows as few as three external components and eliminates the loop compensation and magnetics part selection process.

The 10-mm × 10-mm × 4.3-mm QFN package is easy to solder onto a printed circuit board and allows a compact point-of-load design. Achieves greater than 95% efficiency and excellent power dissipation capability with a thermal impedance of 13.3°C/W. The LMZ31707 offers the flexibility and the feature-set of a discrete point-of-load design and is ideal for powering a wide range of ICs and systems. Advanced packaging technology affords a robust and reliable power solution compatible with standard QFN mounting and testing techniques.

### Simplified Application

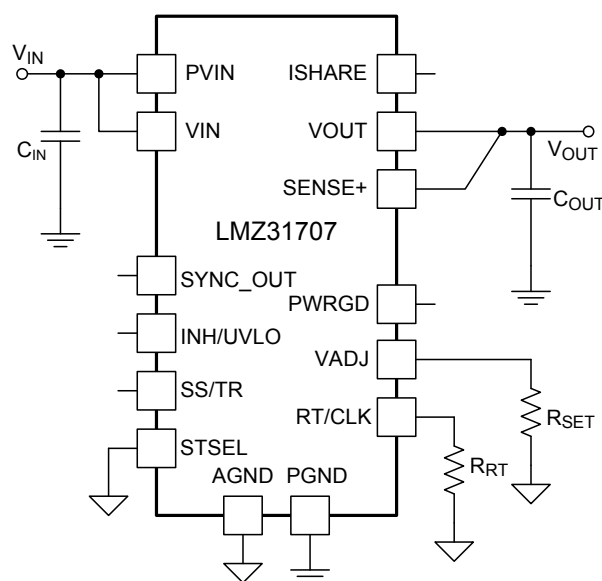

## 4 Revision History

NOTE: Page numbers for previous revisions may differ from page numbers in the current version.

---

### Changes from Revision D (March 2019) to Revision E Page

- Added  $V_{OUT}$  Range values under different  $I_{OUT}$  conditions in [Table 7](#) ..... 24
- 

### Changes from Revision C (April 2018) to Revision D Page

- Added ESD Ratings information ..... 3
  - Corrected TBD values in Synchronization Frequency vs Output Voltage Table ..... 24
- 

### Changes from Revision B (June 2017) to Revision C Page

- Added WEBENCH® design links for the LMZ31707 ..... 1
  - Increased the peak reflow temperature and maximum number of reflows to JEDEC specifications for improved manufacturability ..... 3
  - Added *Device Support* section ..... 29
  - Added *Mechanical, Packaging, and Orderable Information* section ..... 30
- 

### Changes from Revision A (August 2013) to Revision B Page

- Added peak reflow and maximum number of reflows information ..... 3
-

## 5 Specifications

### 5.1 Absolute Maximum Ratings<sup>(1)</sup>

over operating temperature range (unless otherwise noted)

		MIN	MAX	UNIT
Input Voltage	V <sub>IN</sub> , P <sub>VIN</sub>	-0.3	20	V
	INH/UVLO, PWRGD, RT/CLK, SENSE+	-0.3	6	V
	ILIM, VADJ, SS/TR, STSEL, SYNC_OUT, ISHARE, OCP_SEL	-0.3	3	V
Output Voltage	PH	-1	20	V
	PH 10 ns Transient	-3	20	V
	V <sub>OUT</sub>	-0.3	6	V
Source Current	RT/CLK, INH/UVLO		±100	µA
	PH		current limit	A
Sink Current	PH		current limit	A
	P <sub>VIN</sub>		current limit	A
	PWRGD	-0.1	2	mA
Operating Junction Temperature		-40	125 <sup>(2)</sup>	°C
Storage Temperature		-65	150	°C
Peak Reflow Case Temperature <sup>(3)</sup>			245 <sup>(4)</sup>	°C
Maximum Number of Reflows Allowed <sup>(3)</sup>			3 <sup>(4)</sup>	
Mechanical Shock	Mil-STD-883D, Method 2002.3, 1 msec, 1/2 sine, mounted		1500	G
Mechanical Vibration	Mil-STD-883D, Method 2007.2, 20-2000 Hz		20	

- (1) Stresses beyond those listed under absolute maximum ratings may cause permanent damage to the device. These are stress ratings only, and functional operation of the device at these or any other conditions beyond those indicated under recommended operating conditions is not implied. Exposure to absolute-maximum-rated conditions for extended periods may affect device reliability.
- (2) See the temperature derating curves in the Typical Characteristics section for thermal information.
- (3) For soldering specifications, refer to the [Soldering Requirements for BQFN Packages](#) application note.
- (4) Devices with a date code prior to week 14 2018 (1814) have a peak reflow case temperature of 240°C with a maximum of one reflow.

### 5.2 ESD Ratings

		VALUE	UNIT
V <sub>(ESD)</sub> Electrostatic discharge	Human-body model (HBM), per ANSI/ESDA/JEDEC JS-001 <sup>(1)</sup>	±1500	V
	Charged-device model (CDM), per JEDEC specification JESD22-C101 <sup>(2)</sup>	±1000	

- (1) JEDEC document JEP155 states that 500-V HBM allows safe manufacturing with a standard ESD control process.
- (2) JEDEC document JEP157 states that 250-V CDM allows safe manufacturing with a standard ESD control process.

### 5.3 Recommended Operating Conditions

over operating free-air temperature range (unless otherwise noted)

		MIN	NOM	MAX	UNIT
P <sub>VIN</sub>	Input Switching Voltage	2.95		17	V
V <sub>IN</sub>	Input Bias Voltage	4.5		17	V
V <sub>OUT</sub>	Output Voltage	0.6		5.5	V
f <sub>SW</sub>	Switching Frequency	200		1200	kHz

### 5.4 Package Specifications

LMZ31707		UNIT
Weight		1.45 grams
Flammability	Meets UL 94 V-O	
MTBF Calculated reliability	Per Bellcore TR-332, 50% stress, T <sub>A</sub> = 40°C, ground benign	37.4 Mhrs

## 5.5 Thermal Information

THERMAL METRIC <sup>(1)</sup>		LMZ31707	UNIT
		RVQ42	
		42 PINS	
$\theta_{JA}$	Junction-to-ambient thermal resistance <sup>(2)</sup>	13.3	°C/W
$\Psi_{JT}$	Junction-to-top characterization parameter <sup>(3)</sup>	1.6	°C/W
$\Psi_{JB}$	Junction-to-board characterization parameter <sup>(4)</sup>	5.3	°C/W

- (1) For more information about traditional and new thermal metrics, see the [Semiconductor and IC Package Thermal Metrics](#) application report.
- (2) The junction-to-ambient thermal resistance,  $\theta_{JA}$ , applies to devices soldered directly to a 100 mm x 100 mm double-sided PCB with 2-oz. copper and natural convection cooling. Additional airflow reduces  $\theta_{JA}$ .
- (3) The junction-to-top characterization parameter,  $\Psi_{JT}$ , estimates the junction temperature,  $T_J$ , of a device in a real system, using a procedure described in JESD51-2A (sections 6 and 7).  $T_J = \Psi_{JT} * P_{dis} + T_T$ ; where  $P_{dis}$  is the power dissipated in the device and  $T_T$  is the temperature of the top of the device.
- (4) The junction-to-board characterization parameter,  $\Psi_{JB}$ , estimates the junction temperature,  $T_J$ , of a device in a real system, using a procedure described in JESD51-2A (sections 6 and 7).  $T_J = \Psi_{JB} * P_{dis} + T_B$ ; where  $P_{dis}$  is the power dissipated in the device and  $T_B$  is the temperature of the board 1mm from the device.

## 5.6 Electrical Characteristics

Over  $-40^{\circ}\text{C}$  to  $85^{\circ}\text{C}$  free-air temperature,  $P_{VIN} = V_{IN} = 12\text{ V}$ ,  $V_{OUT} = 1.8\text{ V}$ ,  $I_{OUT} = 7\text{ A}$ ,  
 $C_{IN} = 0.1\text{ }\mu\text{F} + 2 \times 22\text{ }\mu\text{F}$  ceramic +  $100\text{ }\mu\text{F}$  bulk,  $C_{OUT} = 4 \times 47\text{ }\mu\text{F}$  ceramic (unless otherwise noted) <sup>(1)</sup>

PARAMETER		TEST CONDITIONS	MIN	TYP	MAX	UNIT		
$I_{OUT}$	Output current	$T_A = 85^{\circ}\text{C}$ , natural convection	0		7	A		
$V_{IN}$	Input bias voltage range	Over output current range	4.5		17	V		
$P_{VIN}$	Input switching voltage range	Over output current range	2.95 <sup>(2)</sup>		17 <sup>(3)</sup>	V		
UVLO	$V_{IN}$ Undervoltage lockout	$V_{IN}$ Increasing		4.0	4.5	V		
		$V_{IN}$ Decreasing	3.5	3.85				
$V_{OUT(adj)}$	Output voltage adjust range	Over output current range	0.6		5.5	V		
$V_{OUT}$	Set-point voltage tolerance	$T_A = 25^{\circ}\text{C}$ , $I_{OUT} = 0\text{ A}$			$\pm 1\%$ <sup>(4)</sup>			
	Temperature variation	$-40^{\circ}\text{C} \leq T_A \leq +85^{\circ}\text{C}$ , $I_{OUT} = 0\text{ A}$		$\pm 0.2\%$				
	Line regulation	Over input voltage range		$\pm 0.1\%$				
	Load regulation	Over output current range		$\pm 0.2\%$				
	Total output voltage variation	Includes set-point, line, load, and temperature variation				$\pm 1.5\%$ <sup>(4)</sup>		
$\eta$	Efficiency	$P_{VIN} = V_{IN} = 12\text{ V}$ $I_O = 4\text{ A}$	$V_{OUT} = 5.0\text{ V}$ , $f_{SW} = 1\text{ MHz}$		94 %			
			$V_{OUT} = 3.3\text{ V}$ , $f_{SW} = 750\text{ kHz}$		92 %			
			$V_{OUT} = 2.5\text{ V}$ , $f_{SW} = 750\text{ kHz}$		90 %			
			$V_{OUT} = 1.8\text{ V}$ , $f_{SW} = 500\text{ kHz}$		89 %			
			$V_{OUT} = 1.2\text{ V}$ , $f_{SW} = 300\text{ kHz}$		87 %			
			$V_{OUT} = 0.9\text{ V}$ , $f_{SW} = 250\text{ kHz}$		85 %			
		$P_{VIN} = V_{IN} = 5\text{ V}$ $I_O = 4\text{ A}$	$V_{OUT} = 3.3\text{ V}$ , $f_{SW} = 750\text{ kHz}$		95 %			
			$V_{OUT} = 2.5\text{ V}$ , $f_{SW} = 750\text{ kHz}$		93 %			
			$V_{OUT} = 1.8\text{ V}$ , $f_{SW} = 500\text{ kHz}$		92 %			
			$V_{OUT} = 1.2\text{ V}$ , $f_{SW} = 300\text{ kHz}$		90 %			
			$V_{OUT} = 0.9\text{ V}$ , $f_{SW} = 250\text{ kHz}$		87 %			
			$V_{OUT} = 0.6\text{ V}$ , $f_{SW} = 200\text{ kHz}$		84 %			
			Output voltage ripple	20 MHz bandwidth		14		mV <sub>P-P</sub>
			$I_{LIM}$	Current limit threshold	ILIM pin open		12	
ILIM pin to AGND		9				A		
Transient response	1.0 A/ $\mu\text{s}$ load step from 25 to 75% $I_{OUT(max)}$	Recovery time		tbd		$\mu\text{s}$		
		$V_{OUT}$ over/undershoot		tbd		mV		

- (1) See the [Light Load Efficiency \(LLE\)](#) section for more information for output voltages < 1.5 V.
- (2) The minimum  $P_{VIN}$  is 2.95 V or ( $V_{OUT} + 0.7\text{ V}$ ), whichever is greater. See for more details.
- (3) The maximum  $P_{VIN}$  voltage is 17 V or ( $22 \times V_{OUT}$ ), whichever is less. See for more details.
- (4) The stated limit of the set-point voltage tolerance includes the tolerance of both the internal voltage reference and the internal adjustment resistor. The overall output voltage tolerance will be affected by the tolerance of the external  $R_{SET}$  resistor.

## Electrical Characteristics (continued)

Over  $-40^{\circ}\text{C}$  to  $85^{\circ}\text{C}$  free-air temperature,  $\text{PV}_{\text{IN}} = \text{V}_{\text{IN}} = 12\text{ V}$ ,  $\text{V}_{\text{OUT}} = 1.8\text{ V}$ ,  $\text{I}_{\text{OUT}} = 7\text{ A}$ ,  
 $\text{C}_{\text{IN}} = 0.1\text{ }\mu\text{F} + 2 \times 22\text{ }\mu\text{F}$  ceramic +  $100\text{ }\mu\text{F}$  bulk,  $\text{C}_{\text{OUT}} = 4 \times 47\text{ }\mu\text{F}$  ceramic (unless otherwise noted) <sup>(1)</sup>

PARAMETER		TEST CONDITIONS	MIN	TYP	MAX	UNIT	
$\text{V}_{\text{INH}}$	Inhibit threshold voltage	Inhibit High Voltage	1.3		open <sup>(5)</sup>	V	
		Inhibit Low Voltage	-0.3		1.1		
$\text{I}_{\text{INH}}$	INH Input current	$\text{V}_{\text{INH}} < 1.1\text{ V}$		-1.15		$\mu\text{A}$	
	INH Hysteresis current	$\text{V}_{\text{INH}} > 1.3\text{ V}$		-3.3		$\mu\text{A}$	
$\text{I}_{\text{I(stby)}}$	Input standby current	INH pin to AGND		2	10	$\mu\text{A}$	
Power Good	PWRGD Thresholds	$\text{V}_{\text{OUT}}$ rising	Good	95%			
			Fault	108%			
		$\text{V}_{\text{OUT}}$ falling	Fault	91%			
			Good	104%			
PWRGD Low Voltage	$\text{I}(\text{PWRGD}) = 0.5\text{ mA}$			0.3	V		
$\text{f}_{\text{SW}}$	Switching frequency	$\text{R}_{\text{RT}} = 169\text{ k}\Omega$	400	500	600	kHz	
$\text{f}_{\text{CLK}}$	Synchronization frequency	CLK Control	200		1200	kHz	
$\text{V}_{\text{CLK-H}}$	CLK High-Level		2.0		5.5	V	
$\text{V}_{\text{CLK-L}}$	CLK Low-Level				0.5	V	
$\text{D}_{\text{CLK}}$	CLK Duty Cycle		20	50	80	%	
	Thermal Shutdown		Thermal shutdown		175		$^{\circ}\text{C}$
		Thermal shutdown hysteresis		10		$^{\circ}\text{C}$	
$\text{C}_{\text{IN}}$	External input capacitance	Ceramic	44 <sup>(6)</sup>			$\mu\text{F}$	
		Non-ceramic		100 <sup>(6)</sup>			
$\text{C}_{\text{OUT}}$	External output capacitance	Ceramic	47 <sup>(7)</sup>	200	1500	$\mu\text{F}$	
		Non-ceramic		220 <sup>(7)</sup>	5000 <sup>(8)</sup>		
		Equivalent series resistance (ESR)				35	m $\Omega$

- (5) This pin has an internal pullup. If it is left open, the device operates when input power is applied. A small, low-leakage MOSFET is recommended for control. When the device is operating and no UVLO resistor divider is present on this pin, the open voltage is typically 2.9 V.
- (6) A minimum of 44  $\mu\text{F}$  of external ceramic capacitance is required across the input ( $\text{V}_{\text{IN}}$  and  $\text{PV}_{\text{IN}}$  connected) for proper operation. An additional 100  $\mu\text{F}$  of bulk capacitance is recommended. It is also recommended to place a 0.1  $\mu\text{F}$  ceramic capacitor directly across the  $\text{PV}_{\text{IN}}$  and  $\text{PGND}$  pins of the device. Locate the input capacitance close to the device. When operating with split  $\text{V}_{\text{IN}}$  and  $\text{PV}_{\text{IN}}$  rails, place 4.7  $\mu\text{F}$  of ceramic capacitance directly at the  $\text{V}_{\text{IN}}$  pin. See [Table 4](#) for more details.
- (7) The amount of required output capacitance varies depending on the output voltage (see [Table 3](#)). The amount of required capacitance must include at least 1x 47- $\mu\text{F}$  ceramic capacitor. Locate the capacitance close to the device. Adding additional capacitance close to the load improves the response of the regulator to load transients. See [Table 3](#) and [Table 4](#) more details.
- (8) When using both ceramic and non-ceramic output capacitors, the combined maximum must not exceed 5000  $\mu\text{F}$ . It may be necessary to increase the slow start time when turning on into the maximum capacitance. See the [Slow Start \(SS/TR\)](#) section for information on adjusting the slow start time.

## 6 Device Information

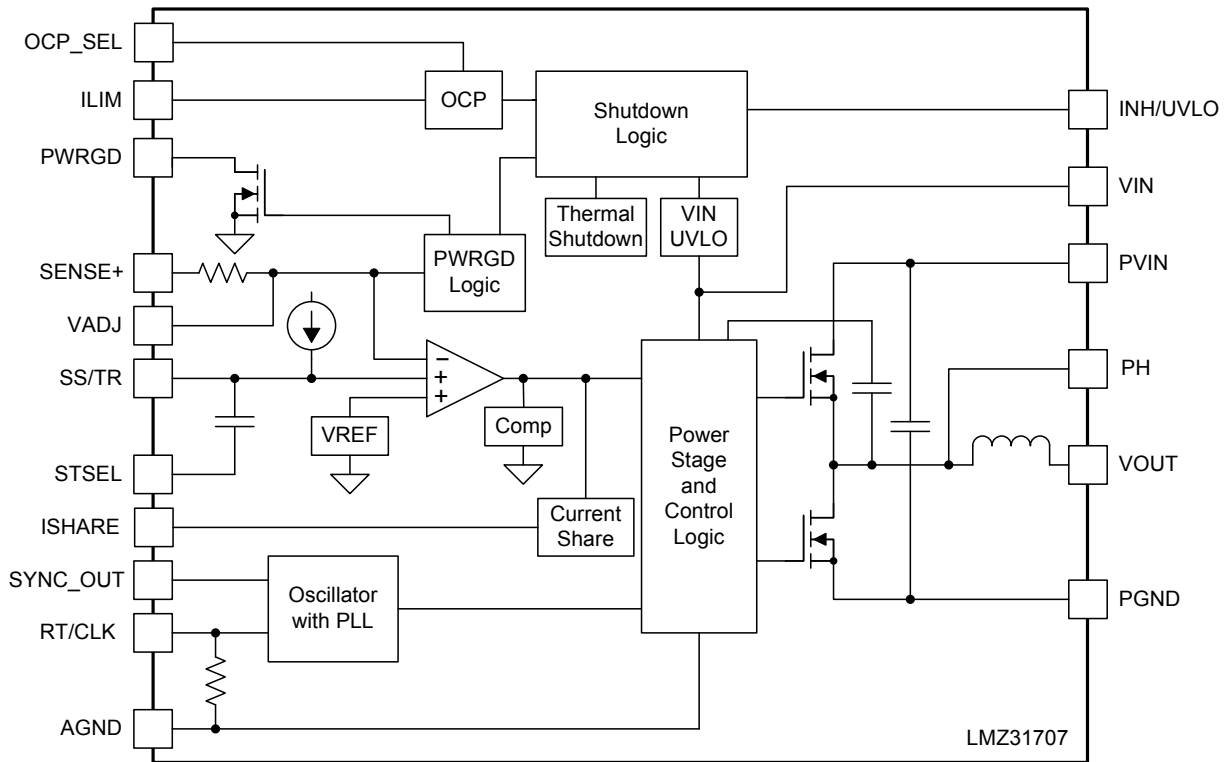
**Functional Block Diagram**

### Pin Functions

TERMINAL		DESCRIPTION
NAME	NO.	
AGND	2	Zero volt reference for the analog control circuit. These pins are not connected together internal to the device and must be connected to one another using an AGND plane of the PCB. These pins are associated with the internal analog ground (AGND) of the device. Keep AGND separate from PGND, as a single connection is made internal to the device. See the <a href="#">Layout Considerations</a> .
	23	
PGND	20	This is the return current path for the power stage of the device. Connect these pins to the load and to the bypass capacitors associated with PVIN and V <sub>OUT</sub> . Keep PGND separate from AGND, as a single connection is made internal to the device.
	21	
	31	
	32	
	33	
VIN	3	Input bias voltage pin. Supplies the control circuitry of the power converter. Connect this pin to the input bias supply. Connect bypass capacitors between this pin and PGND.
PVIN	1	Input switching voltage. Supplies voltage to the power switches of the converter. Connect these pins to the input supply. Connect bypass capacitors between these pins and PGND.
	11	
	12	
	39	
	40	
V <sub>OUT</sub>	34	Output voltage. These pins are connected to the internal output inductor. Connect these pins to the output load and connect external bypass capacitors between these pins and PGND.
	35	
	36	
	37	
	38	
	41	
PH	10	Phase switch node. These pins must be connected to one another using a small copper island under the device for thermal relief. Do not place any external component on these pins or tie them to a pin of another function.
	13	
	14	
	15	
	16	
	17	
	18	
	19	
DNC	5	Do Not Connect. Do not connect these pins to AGND, to another DNC pin, or to any other voltage. These pins are connected to internal circuitry. Each pin must be soldered to an isolated pad.
	9	
	24	
ISHARE	25	Current share pin. Connect this pin to the ISHARE pin of the other LMZ31707 device when paralleling multiple LMZ31707 devices. When unused, treat this pin as a Do Not Connect (DNC) and leave it isolated from all other signals or ground.
OCP_SEL	4	Over current protection select pin. Leave this pin open for hiccup mode operation. Connect this pin to AGND for cycle-by-cycle operation. See the <a href="#">Overcurrent Protection</a> section for more details.
ILIM	6	Current limit pin. Leave this pin open for full current limit threshold. Connect this pin to AGND to reduce the current limit threshold by approximately 3 A.
SYNC_OUT	7	Synchronization output pin. Provides a 180° out-of-phase clock signal.
PWRGD	8	Power Good flag pin. This open drain output asserts low if the output voltage is more than approximately ±6% out of regulation. A pullup resistor is required.
RT/CLK	22	This pin is connected to an internal frequency setting resistor which sets the default switching frequency. An external resistor can be connected from this pin to AGND to increase the frequency. This pin can also be used to synchronize to an external clock.
VADJ	26	Connecting a resistor between this pin and AGND sets the output voltage.
SENSE+	27	Remote sense connection. This pin must be connected to V <sub>OUT</sub> at the load or at the device pins. Connect this pin to V <sub>OUT</sub> at the load for improved regulation.

Pin Functions (continued)

TERMINAL		DESCRIPTION
NAME	NO.	
SS/TR	28	Slow-start and tracking pin. Connecting an external capacitor to this pin adjusts the output voltage rise time. A voltage applied to this pin allows for tracking and sequencing control.
STSEL	29	Slow-start or track feature select. Connect this pin to AGND to enable the internal SS capacitor. Leave this pin open to enable the TR feature.
INH/UVLO	30	Inhibit and UVLO adjust pin. Use an open drain or open collector logic device to ground this pin to control the INH function. A resistor divider between this pin, AGND, and PVIN/VIN sets the UVLO voltage.

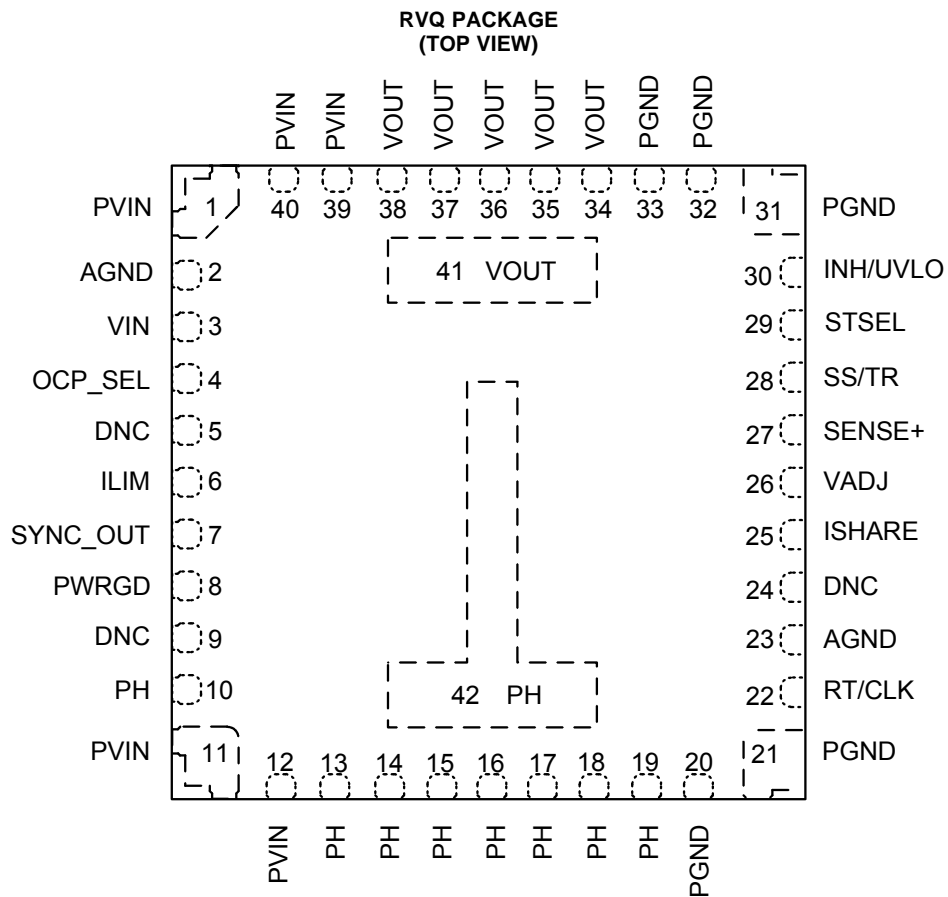

## 7 Typical Characteristics (P<sub>VIN</sub> = V<sub>IN</sub> = 12 V)

The electrical characteristic data has been developed from actual products tested at 25°C. This data is considered typical for the converter. Applies to Figure 1, Figure 2, and Figure 3. The temperature derating curves represent the conditions at which internal components are at or below the manufacturer's maximum operating temperatures. Derating limits apply to devices soldered directly to a 100-mm × 100-mm, 4-layer PCB with 2-oz. copper. Applies to Figure 4.

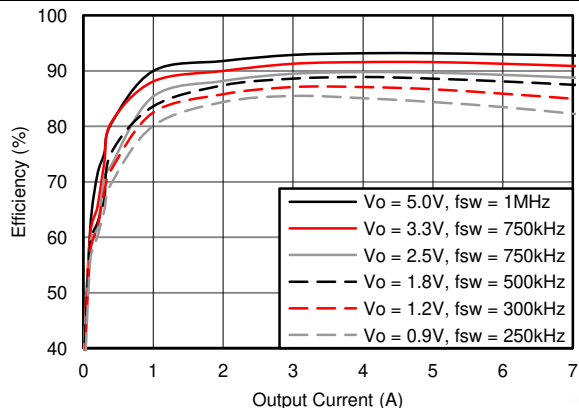

Figure 1. Efficiency versus Output Current

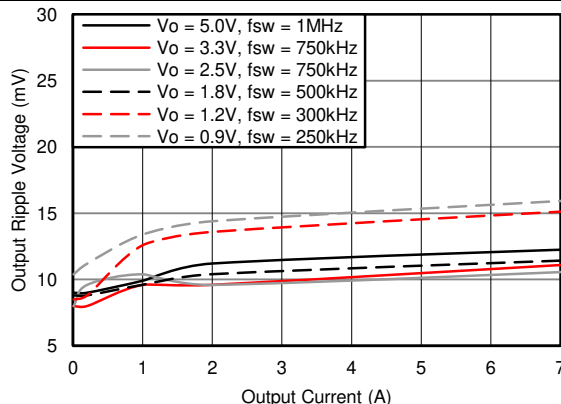

Figure 2. Voltage Ripple versus Output Current

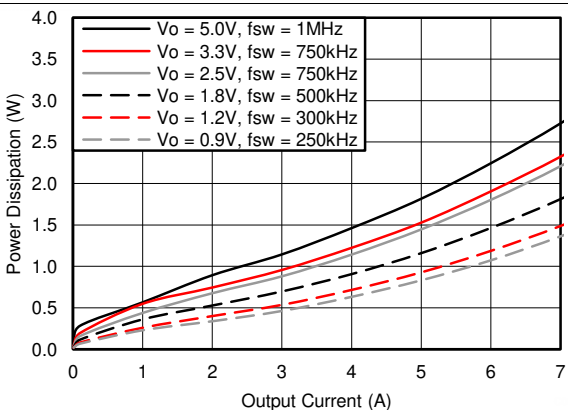

Figure 3. Power Dissipation versus Output Current

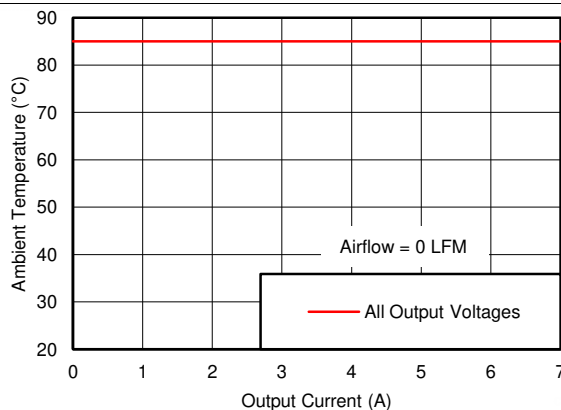

Figure 4. Safe Operating Area

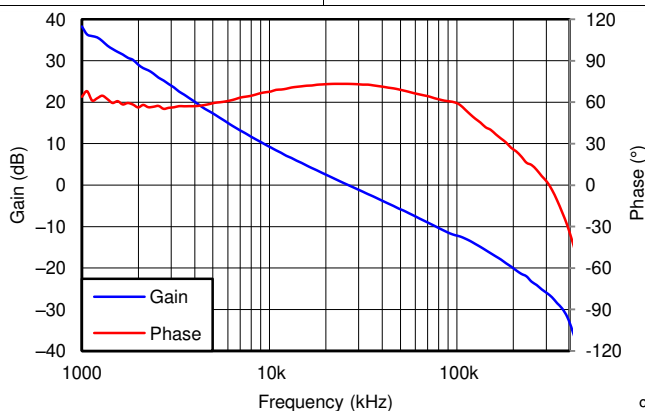

Figure 5. V<sub>OUT</sub> = 1.8 V, I<sub>OUT</sub> = 7 A, C<sub>OUT</sub> = 200 μF Ceramic, f<sub>sw</sub> = 500 kHz

## 8 Typical Characteristics (P<sub>VIN</sub> = V<sub>IN</sub> = 5 V)

The electrical characteristic data has been developed from actual products tested at 25°C. This data is considered typical for the converter. Applies to [Figure 6](#), [Figure 7](#), and [Figure 8](#). The temperature derating curves represent the conditions at which internal components are at or below the manufacturer's maximum operating temperatures. Derating limits apply to devices soldered directly to a 100-mm × 100-mm, 4-layer PCB with 2-oz. copper. Applies to [Figure 9](#).

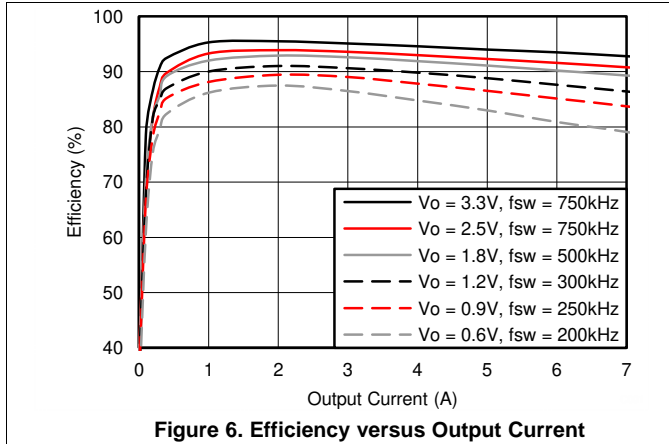

Figure 6. Efficiency versus Output Current

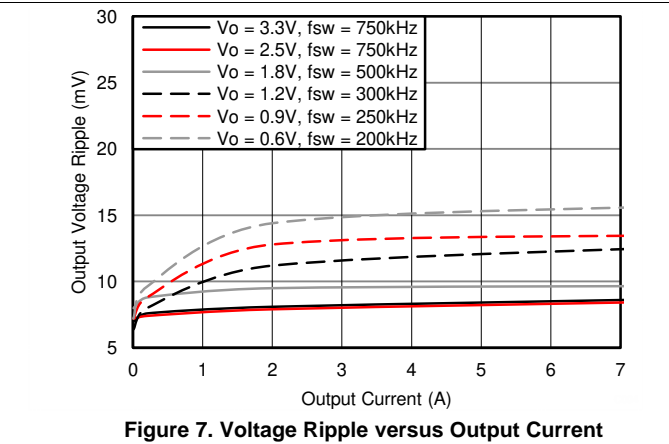

Figure 7. Voltage Ripple versus Output Current

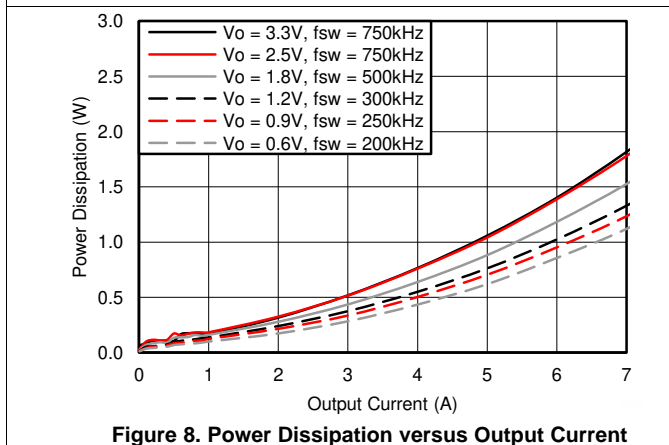

Figure 8. Power Dissipation versus Output Current

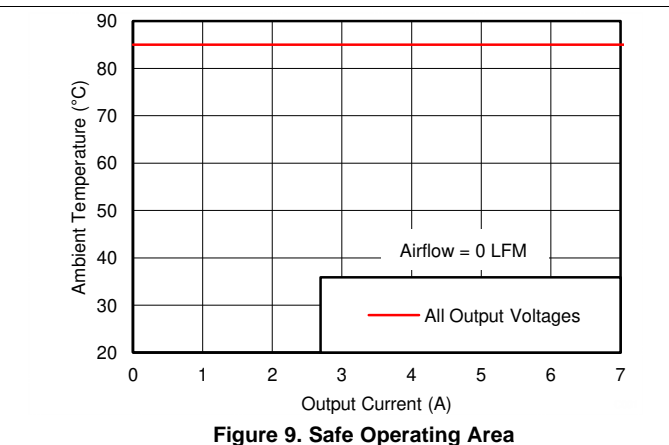

Figure 9. Safe Operating Area

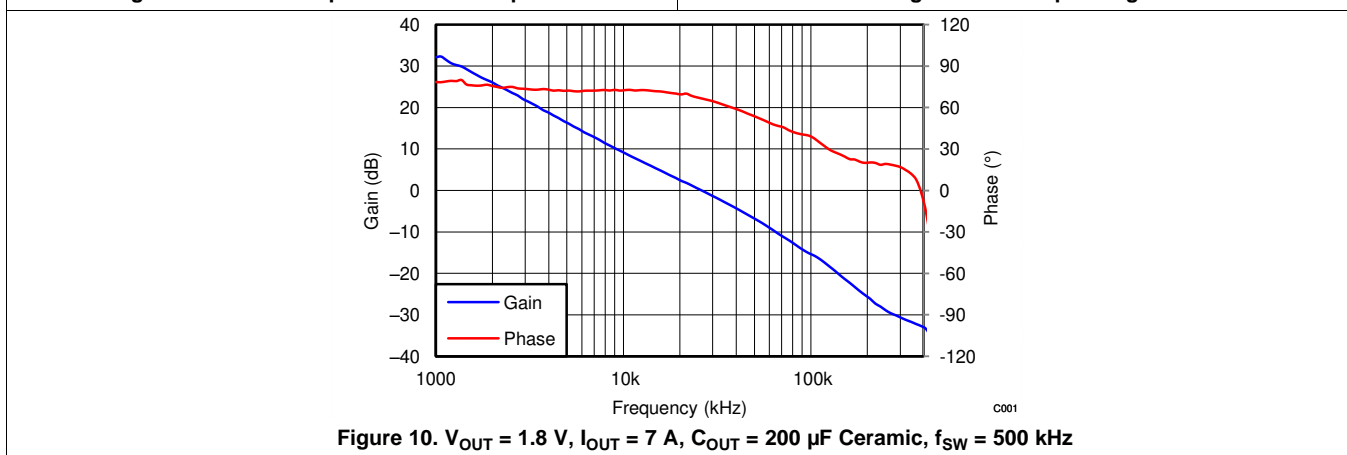

Figure 10. V<sub>OUT</sub> = 1.8 V, I<sub>OUT</sub> = 7 A, C<sub>OUT</sub> = 200 μF Ceramic, f<sub>SW</sub> = 500 kHz

## 9 Typical Characteristics (P<sub>VIN</sub> = 3.3 V, V<sub>IN</sub> = 5 V)

The electrical characteristic data has been developed from actual products tested at 25°C. This data is considered typical for the converter. Applies to Figure 11, Figure 12, and Figure 13. The temperature derating curves represent the conditions at which internal components are at or below the manufacturer's maximum operating temperatures. Derating limits apply to devices soldered directly to a 100-mm x 100-mm, 4-layer PCB with 2-oz. copper. Applies to Figure 14.

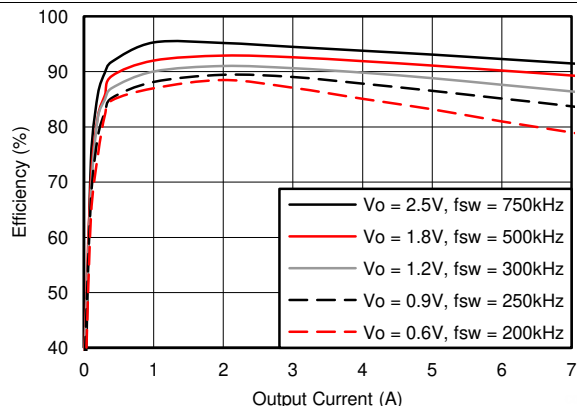

Figure 11. Efficiency versus Output Current

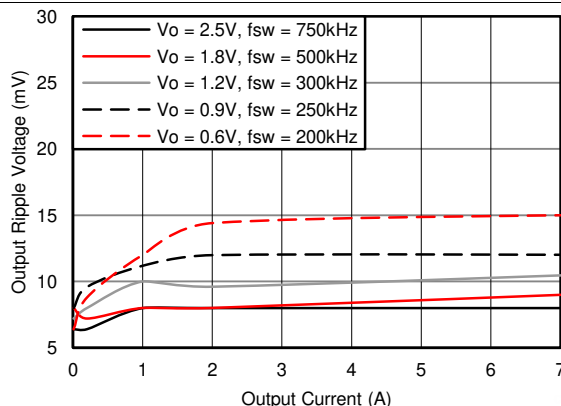

Figure 12. Voltage Ripple versus Output Current

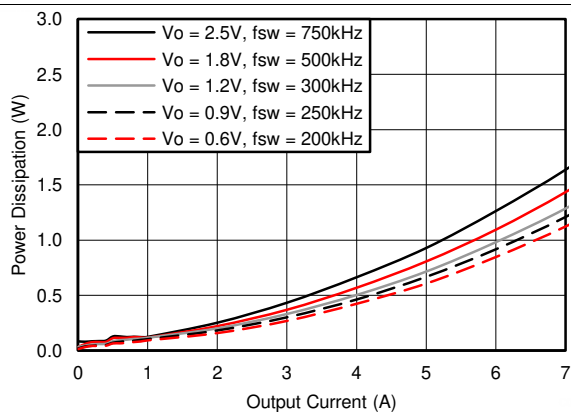

Figure 13. Power Dissipation versus Output Current

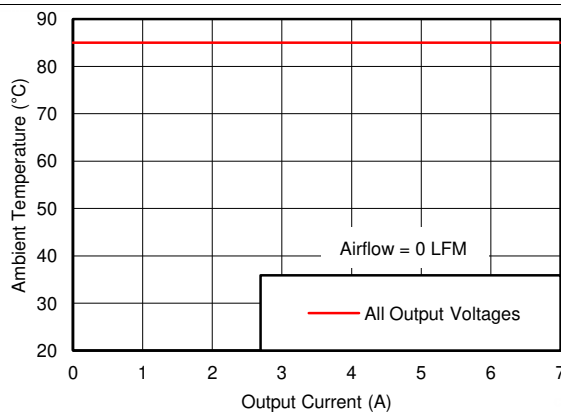

Figure 14. Safe Operating Area

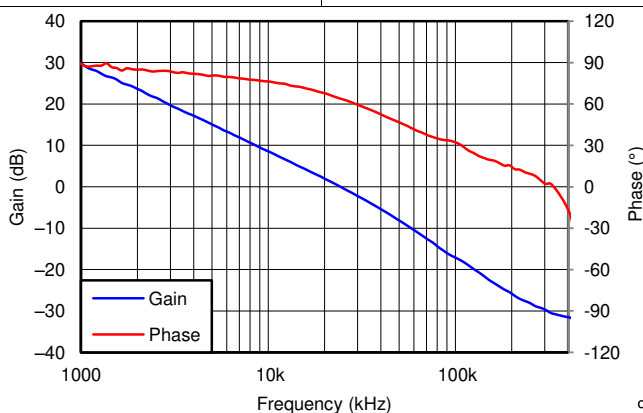

Figure 15. V<sub>OUT</sub> = 1.8 V, I<sub>OUT</sub> = 7 A, C<sub>OUT</sub> = 200 μF Ceramic, f<sub>SW</sub> = 500 kHz

## 10 Application Information

### 10.1 Adjusting the Output Voltage

The VADJ control sets the output voltage of the LMZ31707. The output voltage adjustment range is from 0.6 V to 5.5 V. The adjustment method requires the addition of R<sub>SET</sub>, which sets the output voltage, the connection of SENSE+ to V<sub>OUT</sub>, and in some cases, R<sub>RT</sub> which sets the switching frequency. The R<sub>SET</sub> resistor must be connected directly between the VADJ (pin 26) and AGND (pin 23). The SENSE+ pin (pin 27) must be connected to V<sub>OUT</sub> either at the load for improved regulation or at V<sub>OUT</sub> of the device. The R<sub>RT</sub> resistor must be connected directly between the RT/CLK (pin 22) and AGND (pin 23). [Table 1](#) gives the standard external R<sub>SET</sub> resistor for a number of common bus voltages, along with the recommended R<sub>RT</sub> resistor for that output voltage.

**Table 1. Standard R<sub>SET</sub> Resistor Values for Common Output Voltages**

RESISTORS	OUTPUT VOLTAGE V <sub>OUT</sub> (V)						
	0.9	1.0	1.2	1.8	2.5	3.3	5.0
R <sub>SET</sub> (kΩ)	2.87	2.15	1.43	0.715	0.453	0.316	0.196
R <sub>RT</sub> (kΩ)	1000	1000	487	169	90.9	90.9	63.4

For other output voltages, the value of the required resistor can either be calculated using the following formula, or simply selected from the range of values given in [Table 2](#).

$$R_{SET} = \frac{1.43}{\left(\left(\frac{V_{OUT}}{0.6}\right) - 1\right)} \text{ (k}\Omega\text{)} \quad (1)$$

**Table 2. Standard R<sub>SET</sub> Resistor Values**

V <sub>OUT</sub> (V)	R <sub>SET</sub> (kΩ)	R <sub>RT</sub> (kΩ)	f <sub>sw</sub> (kHz)	V <sub>OUT</sub> (V)	R <sub>SET</sub> (kΩ)	R <sub>RT</sub> (kΩ)	f <sub>sw</sub> (kHz)
0.6	open	OPEN	200	3.1	0.348	90.9	750
0.7	8.66	OPEN	200	3.2	0.332	90.9	750
0.8	4.32	OPEN	200	3.3	0.316	90.9	750
0.9	2.87	1000	250	3.4	0.309	90.9	750
1.0	2.15	1000	250	3.5	0.294	90.9	750
1.1	1.74	1000	250	3.6	0.287	90.9	750
1.2	1.43	487	300	3.7	0.280	90.9	750
1.3	1.24	487	300	3.8	0.267	90.9	750
1.4	1.07	487	300	3.9	0.261	90.9	750
1.5	0.953	487	300	4.0	0.255	90.9	750
1.6	0.866	487	300	4.1	0.243	63.4	1000
1.7	0.787	487	300	4.2	0.237	63.4	1000
1.8	0.715	169	500	4.3	0.232	63.4	1000
1.9	0.665	169	500	4.4	0.226	63.4	1000
2.0	0.619	169	500	4.5	0.221	63.4	1000
2.1	0.576	169	500	4.6	0.215	63.4	1000
2.2	0.536	169	500	4.7	0.210	63.4	1000
2.3	0.511	169	500	4.8	0.205	63.4	1000
2.4	0.475	169	500	4.9	0.200	63.4	1000
2.5	0.453	90.9	750	5.0	0.196	63.4	1000
2.6	0.432	90.9	750	5.1	0.191	63.4	1000
2.7	0.412	90.9	750	5.2	0.187	63.4	1000
2.8	0.392	90.9	750	5.3	0.182	63.4	1000
2.9	0.374	90.9	750	5.4	0.178	63.4	1000
3.0	0.357	90.9	750	5.5	0.174	63.4	1000

## 10.2 Capacitor Recommendations for the LMZ31707 Power Supply

### 10.2.1 Capacitor Technologies

#### 10.2.1.1 Electrolytic, Polymer-Electrolytic Capacitors

When using electrolytic capacitors, high-quality, computer-grade electrolytic capacitors are recommended. Polymer-electrolytic type capacitors are recommended for applications where the ambient operating temperature is less than 0°C. The Sanyo OS-CON capacitor series is suggested due to the lower ESR, higher rated surge, power dissipation, ripple current capability, and small package size. Aluminum electrolytic capacitors provide adequate decoupling over the frequency range of 2 kHz to 150 kHz, and are suitable when ambient temperatures are above 0°C.

#### 10.2.1.2 Ceramic Capacitors

The performance of aluminum electrolytic capacitors is less effective than ceramic capacitors above 150 kHz. Multilayer ceramic capacitors have a low ESR and a resonant frequency higher than the bandwidth of the regulator. They can be used to reduce the reflected ripple current at the input as well as improve the transient response of the output.

#### 10.2.1.3 Tantalum, Polymer-Tantalum Capacitors

Polymer-tantalum type capacitors are recommended for applications where the ambient operating temperature is less than 0°C. The Sanyo POSCAP series and Kemet T530 capacitor series are recommended rather than many other tantalum types due to their lower ESR, higher rated surge, power dissipation, ripple current capability, and small package size. Tantalum capacitors that have no stated ESR or surge current rating are not recommended for power applications.

### 10.2.2 Input Capacitor

The LMZ31707 requires a minimum input capacitance of 44  $\mu\text{F}$  of ceramic type. An additional 100  $\mu\text{F}$  of non-ceramic capacitance is recommended for applications with transient load requirements. The voltage rating of input capacitors must be greater than the maximum input voltage. At worst case, when operating at 50% duty cycle and maximum load, the combined ripple current rating of the input capacitors must be at least 3.5 Arms. [Table 4](#) includes a preferred list of capacitors by vendor. It is also recommended to place a 0.1- $\mu\text{F}$  ceramic capacitor directly across the PVIN and PGND pins of the device. When operating with split VIN and PVIN rails, place 4.7 $\mu\text{F}$  of ceramic capacitance directly at the VIN pin.

### 10.2.3 Output Capacitor

The required output capacitance is determined by the output voltage of the LMZ31707. See [Table 3](#) for the amount of required capacitance. The effects of temperature and capacitor voltage rating must be considered when selecting capacitors to meet the minimum required capacitance. The required output capacitance can be comprised of all ceramic capacitors, or a combination of ceramic and bulk capacitors. The required capacitance must include at least one 47- $\mu\text{F}$  ceramic. When adding additional non-ceramic bulk capacitors, low-ESR devices like the ones recommended in [Table 4](#) are required. The required capacitance above the minimum is determined by actual transient deviation requirements. [Table 4](#) includes a preferred list of capacitors by vendor.

**Table 3. Required Output Capacitance**

V <sub>OUT</sub> RANGE (V)		MINIMUM REQUIRED C <sub>OUT</sub> ( $\mu\text{F}$ )
MIN	MAX	
0.6	< 0.8	500 $\mu\text{F}$ <sup>(1)</sup>
0.8	< 1.2	300 $\mu\text{F}$ <sup>(1)</sup>
1.2	< 3.0	200 $\mu\text{F}$ <sup>(1)</sup>
3.0	< 4.0	100 $\mu\text{F}$ <sup>(1)</sup>
4.0	5.5	47 $\mu\text{F}$ ceramic

(1) Minimum required must include at least one 47  $\mu\text{F}$  ceramic capacitor.

**Table 4. Recommended Input/Output Capacitors<sup>(1)</sup>**

VENDOR	SERIES	PART NUMBER	CAPACITOR CHARACTERISTICS		
			WORKING VOLTAGE (V)	CAPACITANCE (μF)	ESR <sup>(2)</sup> (mΩ)
Murata	X5R	GRM32ER61E226K	25	22	2
TDK	X5R	C3225X5R0J107M	6.3	100	2
TDK	X5R	C3225X5R0J476K	6.3	47	2
Murata	X5R	GRM32ER60J107M	6.3	100	2
Murata	X5R	GRM32ER60J476M	6.3	47	2
Panasonic	EEH-ZA	EEH-ZA1E101XP	25	100	30
Sanyo	POSCAP	16TQC68M	16	68	50
Kemet	T520	T520V107M010ASE025	10	100	25
Sanyo	POSCAP	10TPE220ML	10	220	25
Sanyo	POSCAP	6TPE100MI	6.3	100	25
Sanyo	POSCAP	2R5TPE220M7	2.5	220	7
Kemet	T530	T530D227M006ATE006	6.3	220	6
Kemet	T530	T530D337M006ATE010	6.3	330	10
Sanyo	POSCAP	2TPF330M6	2.0	330	6
Sanyo	POSCAP	6TPE330MFL	6.3	330	15

- (1) **Capacitor Supplier Verification, RoHS, Lead-free, and Material Details**  
 Consult capacitor suppliers regarding availability, material composition, RoHS and lead-free status, and manufacturing process requirements for any capacitors identified in this table.
- (2) Maximum ESR at 100 kHz, 25°C.

### 10.3 Transient Response

**Table 5. Output Voltage Transient Response**

C <sub>IN1</sub> = 3x 22 μF CERAMIC, C <sub>IN2</sub> = 100 μF POLYMER-TANTALUM						
V <sub>OUT</sub> (V)	V <sub>IN</sub> (V)	C <sub>OUT1</sub> CERAMIC	C <sub>OUT2</sub> BULK	VOLTAGE DEVIATION (mV)		RECOVERY TIME (μs)
				2 A LOAD STEP, (1 A/μs)	3.5 A LOAD STEP, (1 A/μs)	
0.6	5	500 μF	220 μF	30	45	90
	12	500 μF	220 μF	30	45	90
0.9	5	300 μF	220 μF	40	65	95
		300 μF	470 μF	35	60	95
	12	300 μF	220 μF	35	60	95
		300 μF	470 μF	30	55	95
1.2	5	200 μF	220 μF	50	85	100
		200 μF	470 μF	45	75	100
	12	200 μF	220 μF	45	80	100
		200 μF	470 μF	40	70	100
1.8	5	200 μF	220 μF	70	105	110
		200 μF	470 μF	65	90	110
	12	200 μF	220 μF	65	100	120
		200 μF	470 μF	60	90	120
3.3	5	100 μF	220 μF	105	177	130
	12	100 μF	220 μF	115	190	150

### 10.4 Transient Waveforms

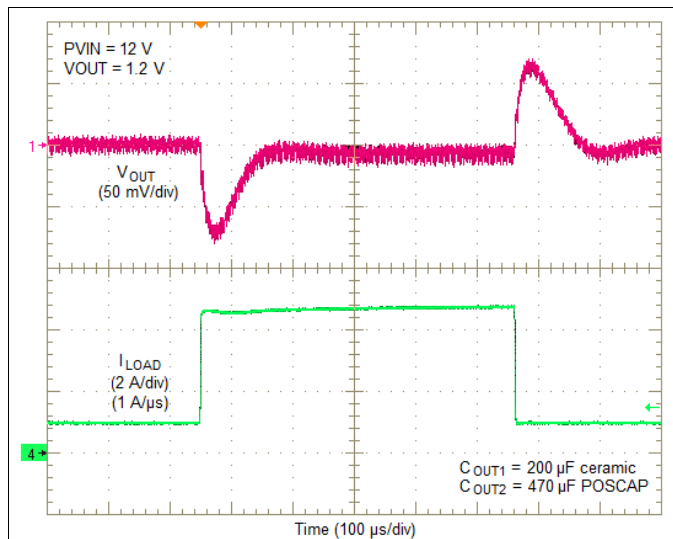

Figure 16. PVIN = 12 V, VOUT = 1.2-V, 3.5-A Load Step

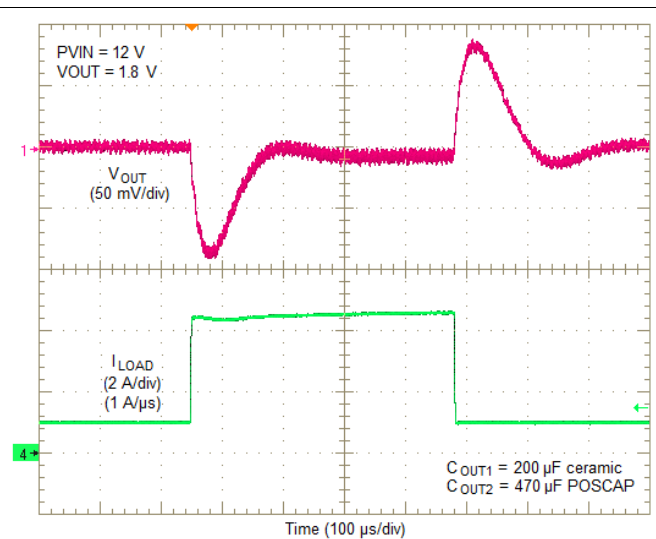

Figure 17. PVIN = 12 V, VOUT = 1.8-V, 3.5-A Load Step

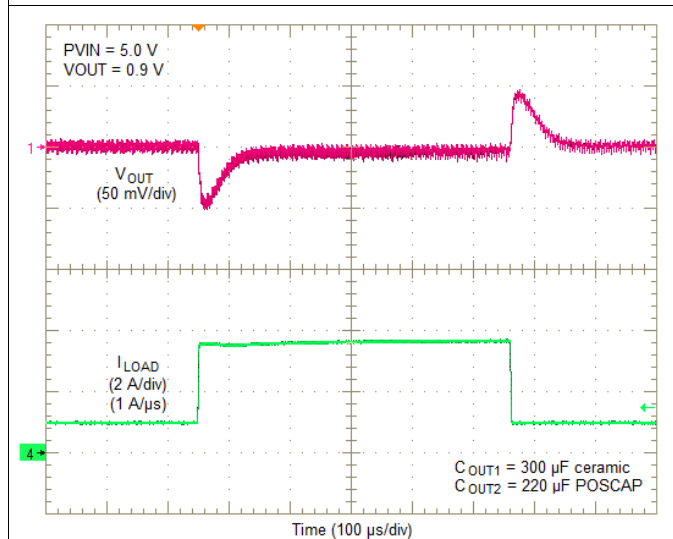

Figure 18. PVIN = 5 V, VOUT = 0.9-V, 2.5-A Load Step

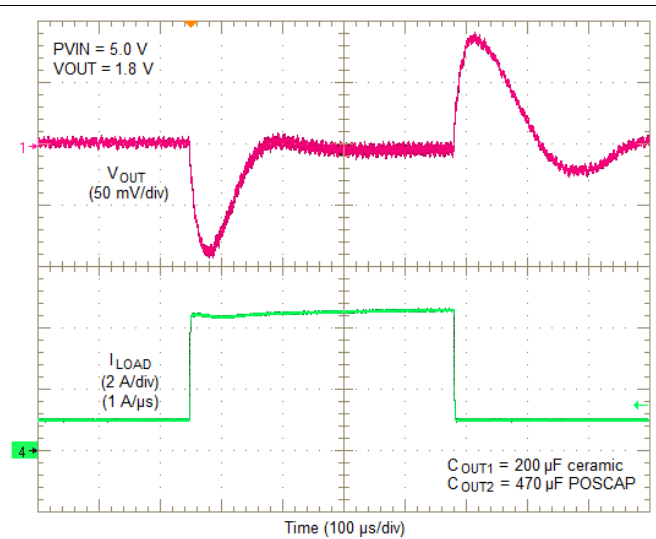
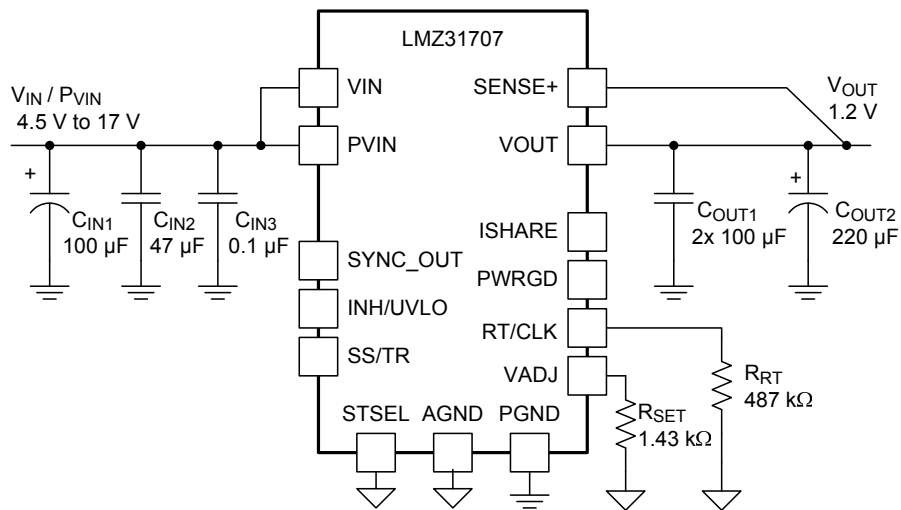
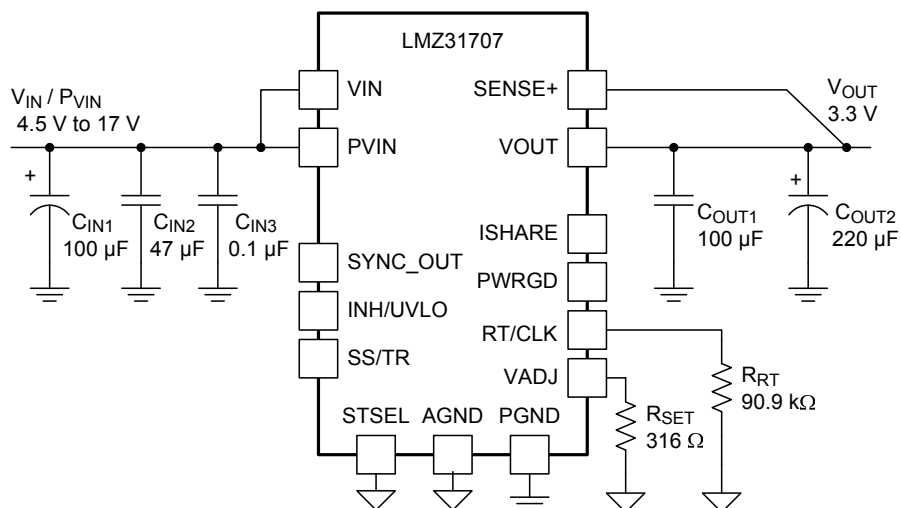

Figure 19. PVIN = 5 V, VOUT = 1.8-V, 3.5-A Load Step

### 10.5 Application Schematics

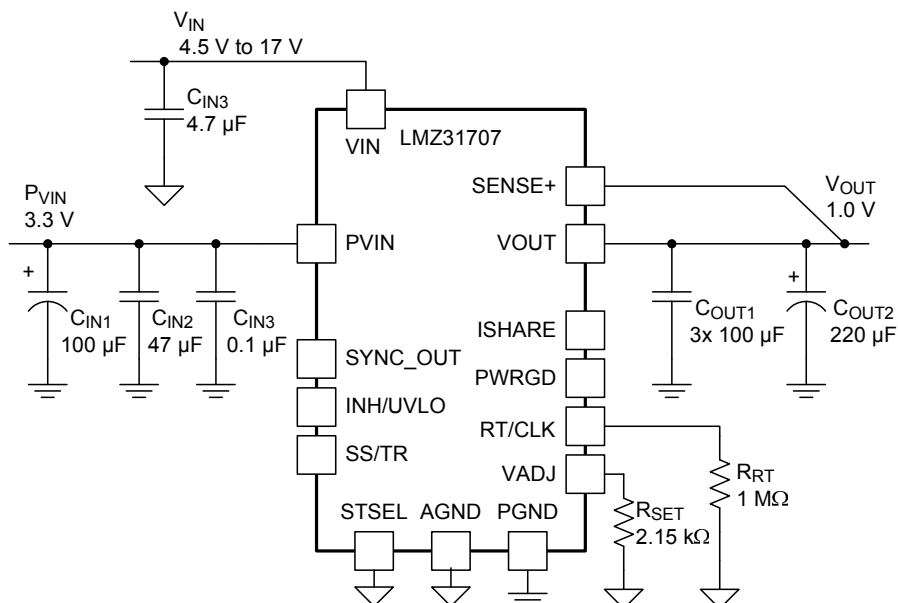

**Figure 20. Typical Schematic**  
 $P_{VIN} = V_{IN} = 4.5 \text{ V to } 17 \text{ V}, V_{OUT} = 1.2 \text{ V}$



**Figure 21. Typical Schematic**  
 $P_{VIN} = V_{IN} = 4.5 \text{ V to } 17 \text{ V}, V_{OUT} = 3.3 \text{ V}$

## Application Schematics (continued)



**Figure 22. Typical Schematic**  
**PVIN = 3.3 V, VIN = 4.5 V to 17 V, VOUT = 1.0 V**

### 10.6 Custom Design With WEBENCH® Tools

Click [here](#) to create a custom design using the LMZ31707 device with the WEBENCH® Power Designer.

1. Start by entering the input voltage ( $V_{IN}$ ), output voltage ( $V_{OUT}$ ), and output current ( $I_{OUT}$ ) requirements.
2. Optimize the design for key parameters such as efficiency, footprint, and cost using the optimizer dial.
3. Compare the generated design with other possible solutions from Texas Instruments.

The WEBENCH Power Designer provides a customized schematic along with a list of materials with real-time pricing and component availability.

In most cases, these actions are available:

- Run electrical simulations to see important waveforms and circuit performance
- Run thermal simulations to understand board thermal performance
- Export customized schematic and layout into popular CAD formats
- Print PDF reports for the design, and share the design with colleagues

Get more information about WEBENCH tools at [www.ti.com/WEBENCH](http://www.ti.com/WEBENCH).

### 10.7 VIN and PVIN Input Voltage

The LMZ31707 allows for a variety of applications by using the VIN and PVIN pins together or separately. The VIN voltage supplies the internal control circuits of the device. The PVIN voltage provides the input voltage to the power converter system.

If tied together, the input voltage for the VIN pin and the PVIN pin can range from 4.5 V to 17 V. If using the VIN pin separately from the PVIN pin, the VIN pin must be greater than 4.5 V, and the PVIN pin can range from as low as 2.95 V to 17 V. When operating from a split rail, it is recommended to supply VIN from 5 V to 12 V, for best performance. A voltage divider connected to the INH/UVLO pin can adjust either input voltage UVLO appropriately. See the [Programmable Undervoltage Lockout \(UVLO\)](#) section of this data sheet for more information.



## 10.12 Light Load Efficiency (LLE)

The LMZ31707 operates in pulse skip mode at light load currents to improve efficiency and decrease power dissipation by reducing switching and gate drive losses.

These pulses can cause the output voltage to rise when there is no load to discharge the energy. For output voltages < 1.5 V, a minimum load is required. The amount of required load can be determined by Equation 2. In most cases, the minimum current drawn by the load circuit will be enough to satisfy this load. Applications requiring a load resistor to meet the minimum load, the added power dissipation will be ≤ 3.6 mW. A single 0402 size resistor across V<sub>OUT</sub> and PGND can be used.

$$I_{\text{MIN}} = 600 \mu\text{A} - \left( \frac{V_{\text{OUT}}}{1.43\text{k} + R_{\text{SET}}} \right) (\text{A}) \quad (2)$$

When V<sub>OUT</sub> = 0.6 V and R<sub>SET</sub> = OPEN, the minimum load current is 600 μA.

## 10.13 Power-Up Characteristics

When configured as shown in the front page schematic, the LMZ31707 produces a regulated output voltage following the application of a valid input voltage. During the power-up, internal soft-start circuitry slows the rate that the output voltage rises, thereby limiting the amount of in-rush current that can be drawn from the input source. Figure 24 shows the start-up waveforms for a LMZ31707, operating from a 5-V input (P<sub>VIN</sub>=V<sub>IN</sub>) and with the output voltage adjusted to 1.8 V. Figure 25 shows the start-up waveforms for a LMZ31707 starting up into a pre-biased output voltage. The waveforms were measured with a 5-A constant current load.

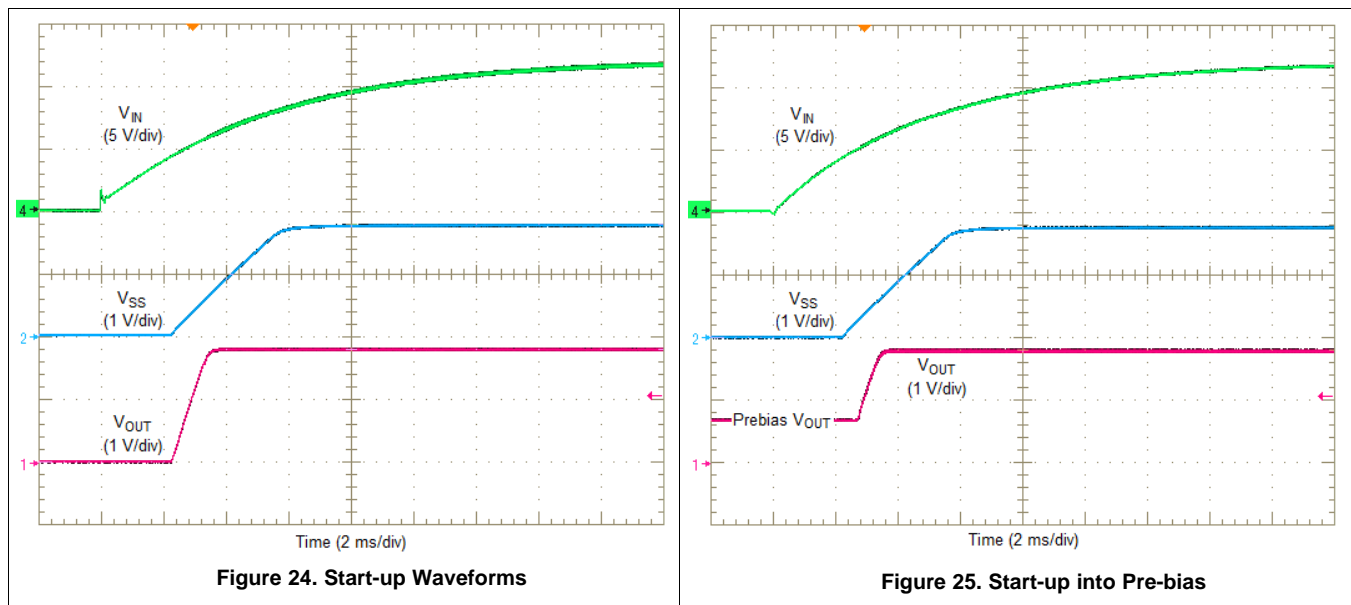

### 10.14 Pre-Biased Start-up

The LMZ31707 has been designed to prevent the low-side MOSFET from discharging a pre-biased output. During pre-biased start-up, the low-side MOSFET does not turn on until the high-side MOSFET has started switching. The high-side MOSFET does not start switching until the slow-start voltage exceeds the voltage on the VADJ pin. Refer to [Figure 25](#).

### 10.15 Remote Sense

The SENSE+ pin must be connected to  $V_{OUT}$  at the load, or at the device pins.

Connecting the SENSE+ pin to  $V_{OUT}$  at the load improves the load regulation performance of the device by allowing it to compensate for any I-R voltage drop between its output pins and the load. An I-R drop is caused by the high output current flowing through the small amount of pin and trace resistance. This should be limited to a maximum of 300 mV.

---

#### NOTE

The remote sense feature is not designed to compensate for the forward drop of nonlinear or frequency dependent components that may be placed in series with the converter output. Examples include OR-ing diodes, filter inductors, ferrite beads, and fuses. When these components are enclosed by the SENSE+ connection, they are effectively placed inside the regulation control loop, which can adversely affect the stability of the regulator.

---

### 10.16 Thermal Shutdown

The internal thermal shutdown circuitry forces the device to stop switching if the junction temperature exceeds 175°C typically. The device reinitiates the power-up sequence when the junction temperature drops below 165°C typically.

### 10.17 Output On/Off Inhibit (INH)

The INH pin provides electrical on/off control of the device. Once the INH pin voltage exceeds the threshold voltage, the device starts operation. If the INH pin voltage is pulled below the threshold voltage, the regulator stops switching and enters low quiescent current state. The INH pin has an internal pullup current source, allowing the user to float the INH pin for enabling the device.

If an application requires controlling the INH pin, use an open drain/collector device, or a suitable logic gate to interface with the pin. Using a voltage supervisor to control the INH pin allows control of the turnon and turnoff of the device as opposed to relying on the ramp up or down if the input voltage source.

Figure 26 shows the typical application of the inhibit function. Turning Q1 on applies a low voltage to the inhibit control (INH) pin and disables the output of the supply, shown in Figure 27. If Q1 is turned off, the supply executes a soft-start power-up sequence, as shown in Figure 28. A regulated output voltage is produced within 2 ms. The waveforms were measured with a 5-A constant current load.

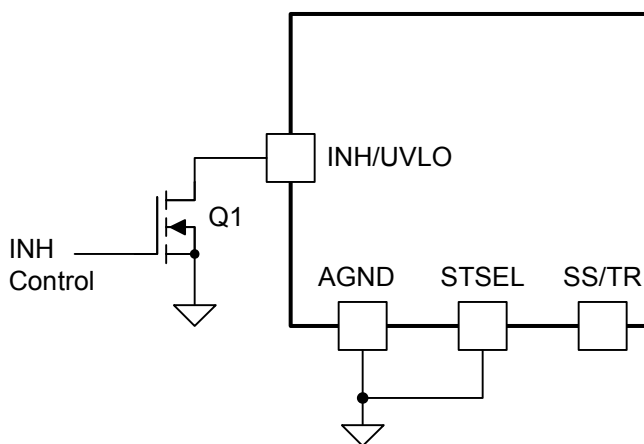

Figure 26. Typical Inhibit Control

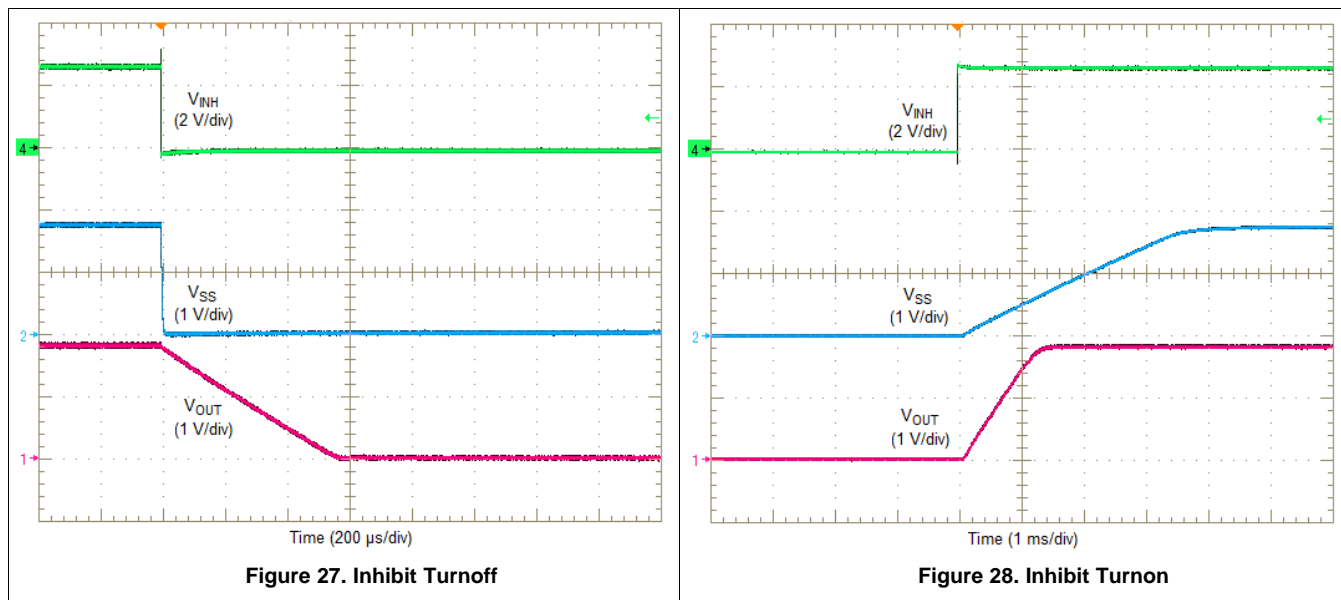

Figure 27. Inhibit Turnoff

Figure 28. Inhibit Turnon

## 10.18 Slow Start (SS/TR)

Connecting the STSEL pin to AGND and leaving SS/TR pin open enables the internal SS capacitor with a slow-start interval of approximately 1.2 ms. Adding additional capacitance between the SS pin and AGND increases the slow-start time. Increasing the slow-start time reduces inrush current seen by the input source and reduce the current seen by the device when charging the output capacitors. To avoid the activation of current limit and ensure proper start-up, the SS capacitor can need to be increased when operating near the maximum output capacitance limit.

Figure 29 shows an additional SS capacitor connected to the SS/TR pin and the STSEL pin connected to AGND. See Table 6 for SS capacitor values and timing interval.

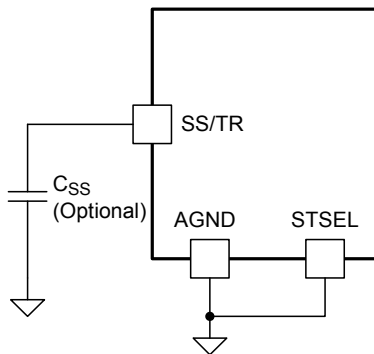

**Figure 29. Slow-Start Capacitor (C<sub>SS</sub>) and STSEL Connection**

**Table 6. Slow-Start Capacitor Values and Slow-Start Time**

C <sub>SS</sub> (nF)	OPEN	3.3	4.7	10	15	22	33
SS Time (msec)	1.2	2.1	2.5	3.8	5.1	7.0	9.8

## 10.19 Overcurrent Protection

For protection against load faults, the LMZ31707 incorporates output overcurrent protection. The overcurrent protection mode can be selected using the OCP\_SEL pin. Leaving the OCP\_SEL pin open selects hiccup mode and connecting it to AGND selects cycle-by-cycle mode. In hiccup mode, applying a load that exceeds the overcurrent threshold of the regulator causes the regulated output to shut down. Following shutdown, the module periodically attempts to recover by initiating a soft-start power-up as shown in Figure 30. This is described as a hiccup mode of operation, whereby the module continues in a cycle of successive shutdown and power-up until the load fault is removed. During this period, the average current flowing into the fault is significantly reduced which reduces power dissipation. Once the fault is removed, the module automatically recovers and returns to normal operation as shown in Figure 31.

In cycle-by-cycle mode, applying a load that exceeds the overcurrent threshold of the regulator limits the output current and reduces the output voltage as shown in Figure 32. During this period, the current flowing into the fault remains high causing the power dissipation to stay high as well. Once the overcurrent condition is removed, the output voltage returns to the set-point voltage as shown in Figure 33.

Overcurrent Protection (continued)

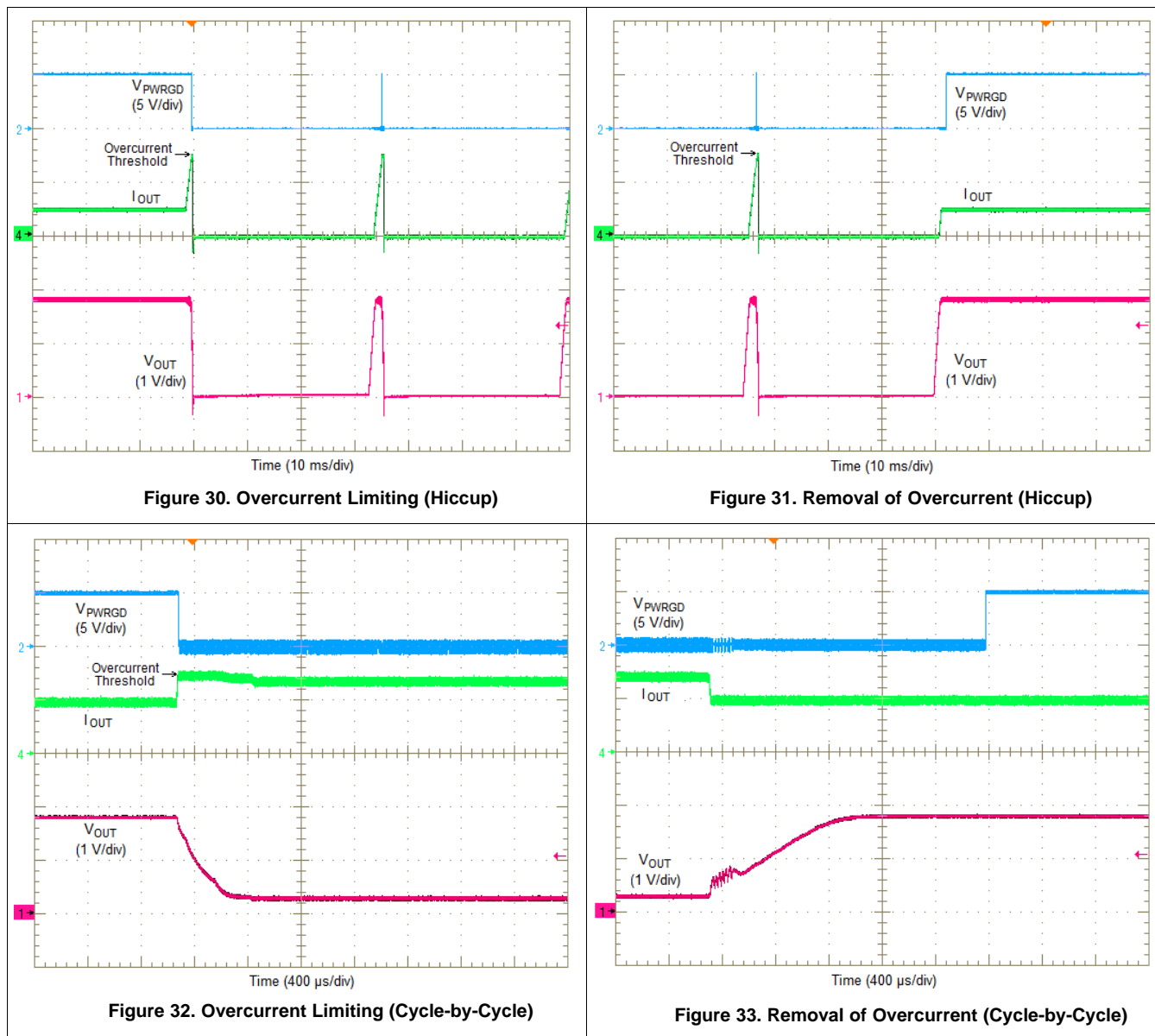

## 10.20 Synchronization (CLK)

An internal phase locked loop (PLL) has been implemented to allow synchronization between 200 kHz and 1200 kHz, and to easily switch from RT mode to CLK mode. To implement the synchronization feature, connect a square wave clock signal to the RT/CLK pin with a duty cycle between 20% to 80%. The clock signal amplitude must transition lower than 0.5 V and higher than 2.0 V. The start of the switching cycle is synchronized to the falling edge of RT/CLK pin. In applications where both RT mode and CLK mode are needed, the device can be configured as shown in [Figure 34](#).

Before the external clock is present, the device works in RT mode and the switching frequency is set by RT resistor. When the external clock is present, the CLK mode overrides the RT mode. The first time the CLK pin is pulled above the RT/CLK high threshold (2.0 V), the device switches from RT mode to CLK mode and the RT/CLK pin becomes high impedance as the PLL starts to lock onto the frequency of the external clock. It is not recommended to switch from CLK mode back to RT mode because the internal switching frequency drops to 100 kHz first before returning to the switching frequency set by the RT resistor ( $R_{RT}$ ).

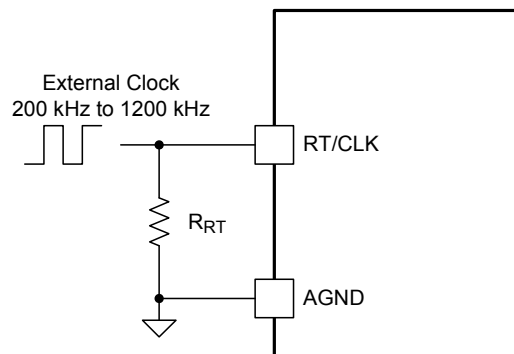

**Figure 34. RT/CLK Configuration**

The switching frequency must be selected based on the output voltage of the device being synchronized. [Table 7](#) shows the allowable frequencies for a given range of output voltages. The allowable switching frequency changes based on the maximum output current ( $I_{OUT}$ ) of an application. The table shows the  $V_{OUT}$  range when  $I_{OUT} \leq 7$  A, 6 A, and 5 A. For the most efficient solution, always synchronize to the lowest allowable frequency. For example, an application requires synchronizing three LMZ31707 devices with output voltages of 1.0 V, 1.2 V, and 1.8 V, all powered from  $P_{VIN} = 12$  V. [Table 7](#) shows that all three output voltages should be synchronized to 300 kHz.

**Table 7. Allowable Switching Frequency versus Output Voltage**

SWITCHING FREQUENCY (kHz)	$P_{VIN} = 12$ V			$P_{VIN} = 5$ V		
	$V_{OUT}$ RANGE (V)			$V_{OUT}$ RANGE (V)		
	$I_{OUT} \leq 7$ A	$I_{OUT} \leq 6$ A	$I_{OUT} \leq 5$ A	$I_{OUT} \leq 7$ A	$I_{OUT} \leq 6$ A	$I_{OUT} \leq 5$ A
200	0.6 - 1.2	0.6 - 1.5	0.6 - 1.9	0.6 - 4.3	0.6 - 4.3	0.6 - 4.3
300	0.8 - 1.9	0.8 - 2.6	0.8 - 3.5	0.6 - 4.3	0.6 - 4.3	0.6 - 4.3
400	1.1 - 2.7	1.1 - 4.1	1.1 - 5.5	0.6 - 4.3	0.6 - 4.3	0.6 - 4.3
500	1.4 - 3.9	1.4 - 5.5	1.4 - 5.5	0.6 - 4.3	0.6 - 4.3	0.6 - 4.3
600	1.6 - 5.5	1.6 - 5.5	1.6 - 5.5	0.9 - 4.2	0.6 - 4.2	0.9 - 4.2
700	1.9 - 5.5	1.8 - 5.5	1.8 - 5.5	0.9 - 4.1	0.9 - 4.1	1.0 - 4.1
800	2.1 - 5.5	2.1 - 5.5	2.1 - 5.5	1.2 - 4.0	1.0 - 4.0	1.0 - 4.0
900	2.4 - 5.5	2.4 - 5.5	2.4 - 5.5	1.2 - 3.9	1.1 - 3.9	1.1 - 3.9
1000	2.7 - 5.5	2.7 - 5.5	2.7 - 5.5	1.2 - 3.8	1.2 - 3.8	1.2 - 3.8
1100	2.9 - 5.5	2.9 - 5.5	2.9 - 5.5	1.5 - 3.7	1.4 - 3.7	1.4 - 3.7
1200	3.2 - 5.5	3.2 - 5.5	3.2 - 5.5	1.5 - 3.6	1.5 - 3.6	1.5 - 3.6

### 10.21 Sequencing (SS/TR)

Many of the common power supply sequencing methods can be implemented using the SS/TR, INH and PWRGD pins. The sequential method is illustrated in Figure 35 using two LMZ31707 devices. The PWRGD pin of the first device is coupled to the INH pin of the second device which enables the second power supply once the primary supply reaches regulation. Figure 36 shows sequential turnon waveforms of two LMZ31707 devices.

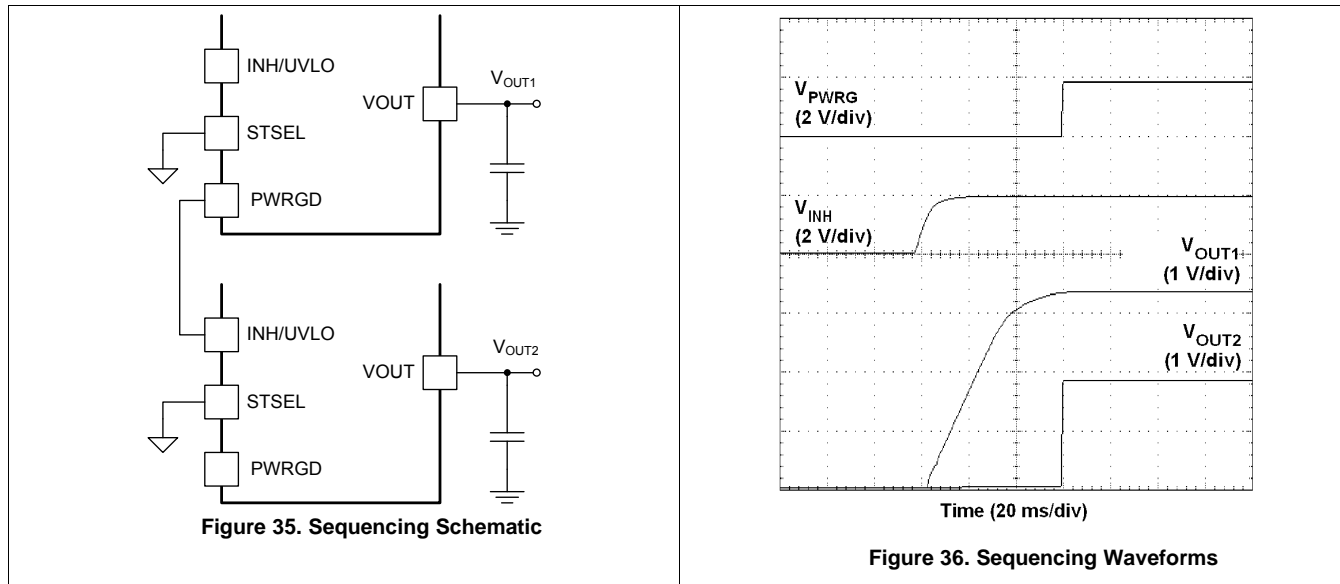

Simultaneous power supply sequencing can be implemented by connecting the resistor network of R1 and R2 shown in Figure 37 to the output of the power supply that needs to be tracked or to another voltage reference source. The tracking voltage must exceed 750 mV before V<sub>OUT2</sub> reaches its set-point voltage. The PWRGD output of the V<sub>OUT2</sub> device can remain low if the tracking voltage does not exceed 1.4 V. Figure 38 shows simultaneous turnon waveforms of two LMZ31707 devices. Use Equation 3 and Equation 4 to calculate the values of R1 and R2.

$$R1 = \frac{(V_{OUT2} \times 12.6)}{0.6} \text{ (k}\Omega\text{)} \quad (3)$$

$$R2 = \frac{0.6 \times R1}{(V_{OUT2} - 0.6)} \text{ (k}\Omega\text{)} \quad (4)$$

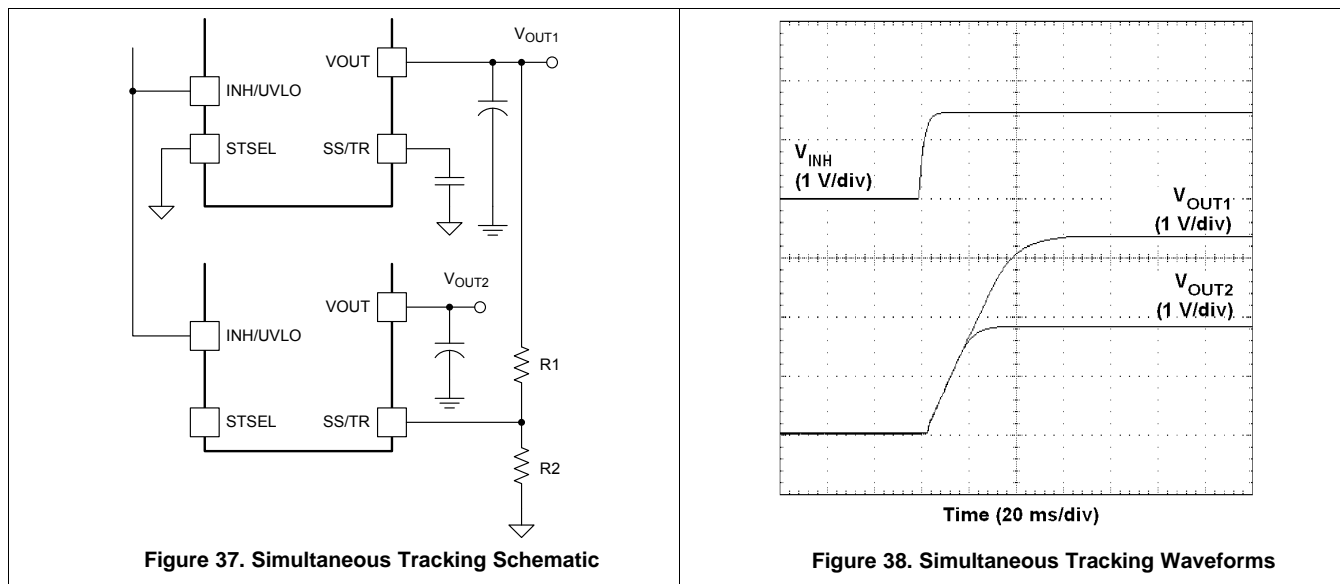

### 10.22 Programmable Undervoltage Lockout (UVLO)

The LMZ31707 implements internal UVLO circuitry on the VIN pin. The device is disabled when the VIN pin voltage falls below the internal VIN UVLO threshold. The internal VIN UVLO rising threshold is 4.5 V (max) with a typical hysteresis of 150 mV.

If an application requires either a higher UVLO threshold on the VIN pin or a higher UVLO threshold for a combined VIN and PVIN, then the UVLO pin can be configured as shown in [Figure 39](#) or [Figure 40](#). [Table 8](#) lists standard values for  $R_{UVLO1}$  and  $R_{UVLO2}$  to adjust the VIN UVLO voltage up.

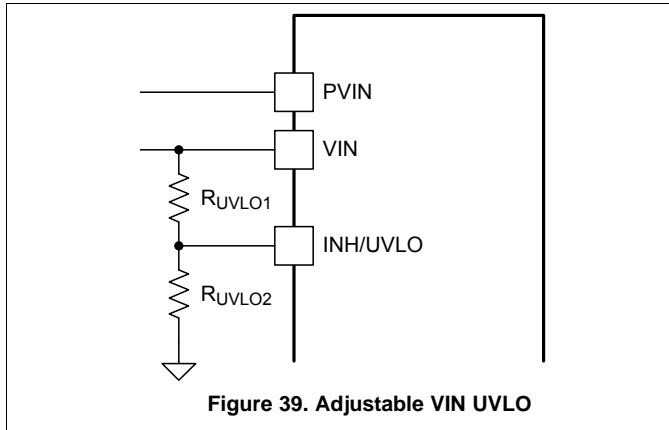

Figure 39. Adjustable VIN UVLO

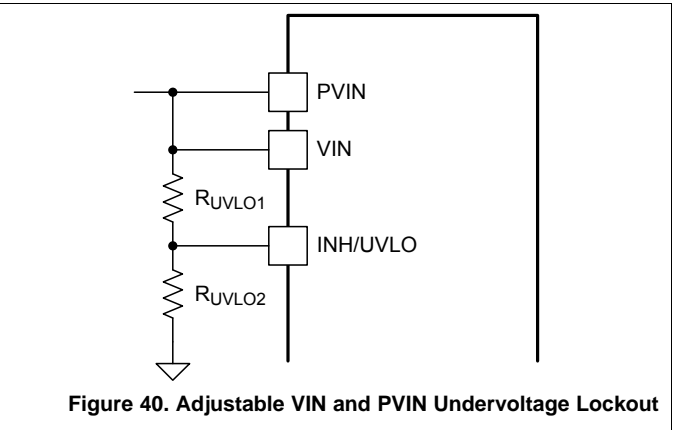

Figure 40. Adjustable VIN and PVIN Undervoltage Lockout

Table 8. Standard Resistor values for Adjusting VIN UVLO

VIN UVLO (V)	5.0	5.5	6.0	6.5	7.0	7.5	8.0	8.5	9.0	9.5	10.0
$R_{UVLO1}$ (k $\Omega$ )	68.1	68.1	68.1	68.1	68.1	68.1	68.1	68.1	68.1	68.1	68.1
$R_{UVLO2}$ (k $\Omega$ )	21.5	18.7	16.9	15.4	14.0	13.0	12.1	11.3	10.5	9.76	9.31
Hysteresis (mV)	400	415	430	450	465	480	500	515	530	550	565

For a split rail application, if a secondary UVLO on PVIN is required, VIN must be  $\geq 4.5$  V. [Figure 41](#) shows the PVIN UVLO configuration. Use [Table 9](#) to select  $R_{UVLO1}$  and  $R_{UVLO2}$  for PVIN. If PVIN UVLO is set for less than 3.5 V, a 5.1-V zener diode should be added to clamp the voltage on the UVLO pin below 6 V.

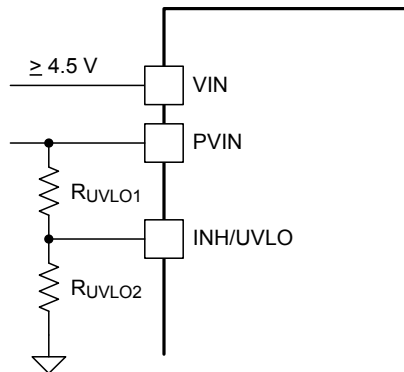

Figure 41. Adjustable PVIN Undervoltage Lockout, (VIN  $\geq 4.5$  V)

Table 9. Standard Resistor Values for Adjusting PVIN UVLO, (VIN  $\geq 4.5$  V)

PVIN UVLO (V)	2.9	3.0	3.5	4.0	4.5	For higher PVIN UVLO voltages, see <a href="#">Table 8</a> for resistor values
$R_{UVLO1}$ (k $\Omega$ )	68.1	68.1	68.1	68.1	68.1	
$R_{UVLO2}$ (k $\Omega$ )	47.5	44.2	34.8	28.7	24.3	
Hysteresis (mV)	330	335	350	365	385	

### 10.23 Layout Considerations

To achieve optimal electrical and thermal performance, an optimized PCB layout is required. Figure 42 through Figure 45 shows a typical PCB layout. Some considerations for an optimized layout are:

- Use large copper areas for power planes (PVIN, V<sub>OUT</sub>, and PGND) to minimize conduction loss and thermal stress.
- Place ceramic input and output capacitors close to the device pins to minimize high frequency noise.
- Locate additional output capacitors between the ceramic capacitor and the load.
- Keep AGND and PGND separate from one another.
- Place R<sub>SET</sub>, R<sub>RT</sub>, and C<sub>SS</sub> as close as possible to their respective pins.
- Use multiple vias to connect the power planes to internal layers.

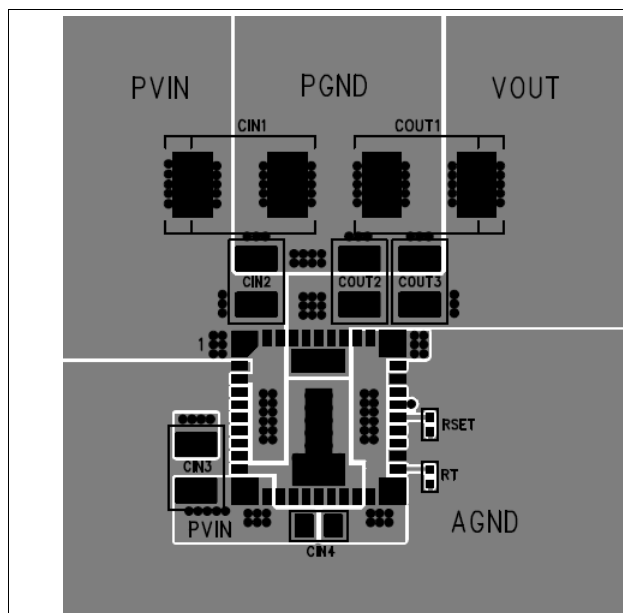

Figure 42. Typical Top-Layer Layout

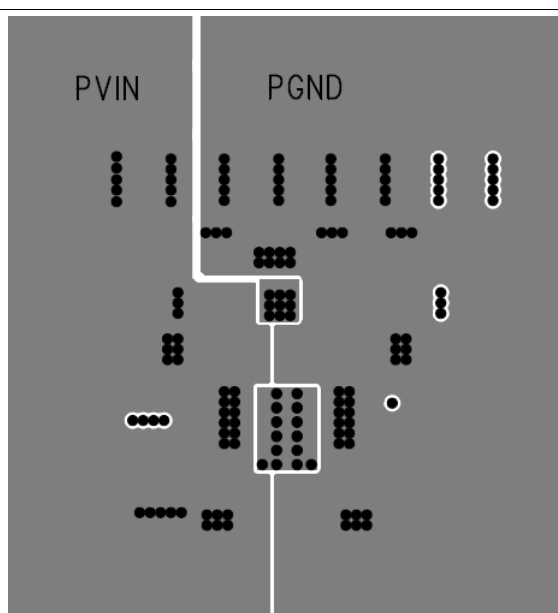

Figure 43. Typical Layer-2 Layout

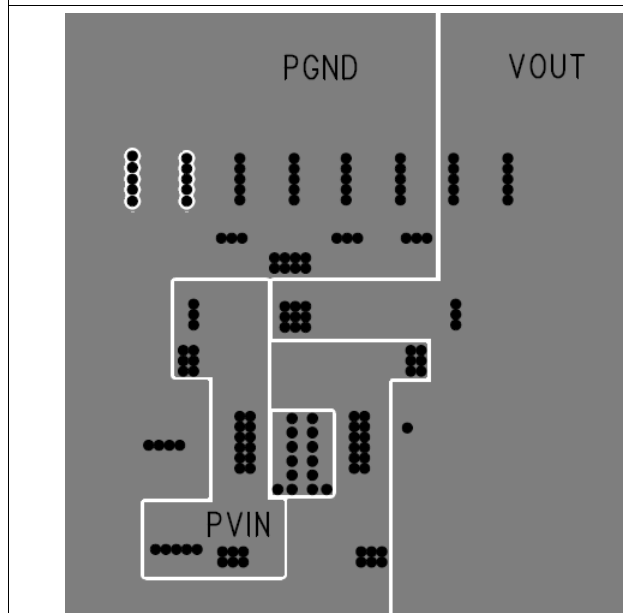

Figure 44. Typical Layer-3 Layout

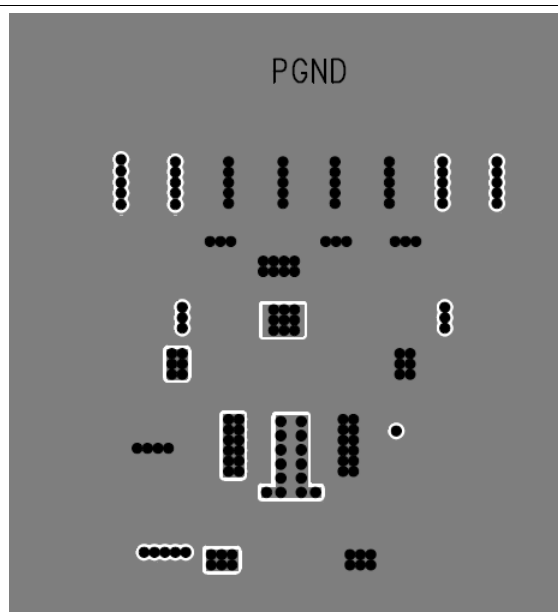
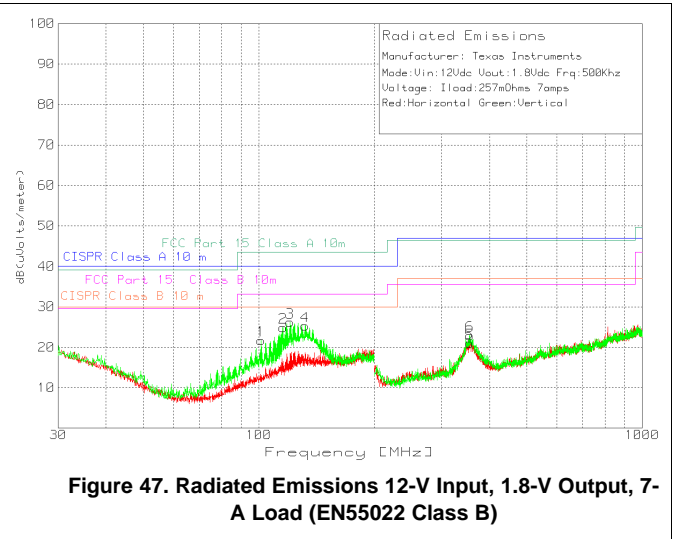
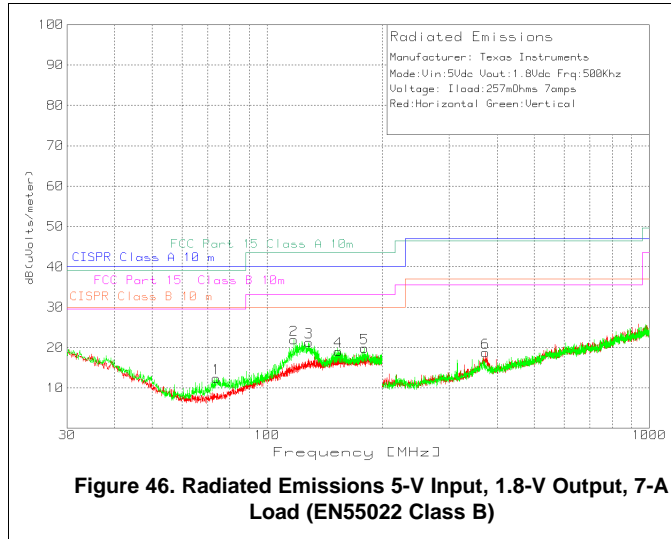

Figure 45. Typical Bottom-Layer Layout

## 10.24 EMI

The LMZ31707 is compliant with EN55022 Class B radiated emissions. [Figure 46](#) and [Figure 47](#) show typical examples of radiated emissions plots for the LMZ31707 operating from 5 V and 12 V, respectively. Both graphs include the plots of the antenna in the horizontal and vertical positions.



## 11 Device and Documentation Support

### 11.1 Device Support

#### 11.1.1 Development Support

##### 11.1.1.1 Custom Design With WEBENCH® Tools

Click [here](#) to create a custom design using the LMZ31707 device with the WEBENCH® Power Designer.

1. Start by entering the input voltage ( $V_{IN}$ ), output voltage ( $V_{OUT}$ ), and output current ( $I_{OUT}$ ) requirements.
2. Optimize the design for key parameters such as efficiency, footprint, and cost using the optimizer dial.
3. Compare the generated design with other possible solutions from Texas Instruments.

The WEBENCH Power Designer provides a customized schematic along with a list of materials with real-time pricing and component availability.

In most cases, these actions are available:

- Run electrical simulations to see important waveforms and circuit performance
- Run thermal simulations to understand board thermal performance
- Export customized schematic and layout into popular CAD formats
- Print PDF reports for the design, and share the design with colleagues

Get more information about WEBENCH tools at [www.ti.com/WEBENCH](http://www.ti.com/WEBENCH).

### 11.2 Documentation Support

#### 11.2.1 Related Documentation

For related documentation see the following:

[Soldering Requirements for BQFN Packages Application Report](#)

### 11.3 Receiving Notification of Documentation Updates

To receive notification of documentation updates, navigate to the device product folder on ti.com. In the upper right corner, click on *Alert me* to register and receive a weekly digest of any product information that has changed. For change details, review the revision history included in any revised document.

### 11.4 Support Resources

[TI E2E™ support forums](#) are an engineer's go-to source for fast, verified answers and design help — straight from the experts. Search existing answers or ask your own question to get the quick design help you need.

Linked content is provided "AS IS" by the respective contributors. They do not constitute TI specifications and do not necessarily reflect TI's views; see TI's [Terms of Use](#).

### 11.5 Trademarks

Eco-mode, E2E are trademarks of Texas Instruments.

WEBENCH, SIMPLE SWITCHER are registered trademarks of Texas Instruments.

All other trademarks are the property of their respective owners.

### 11.6 Electrostatic Discharge Caution



This integrated circuit can be damaged by ESD. Texas Instruments recommends that all integrated circuits be handled with appropriate precautions. Failure to observe proper handling and installation procedures can cause damage.

ESD damage can range from subtle performance degradation to complete device failure. Precision integrated circuits may be more susceptible to damage because very small parametric changes could cause the device not to meet its published specifications.

### 11.7 Glossary

[SLYZ022](#) — *TI Glossary*.

This glossary lists and explains terms, acronyms, and definitions.

## 12 Mechanical, Packaging, and Orderable Information

The following pages include mechanical, packaging, and orderable information. This information is the most current data available for the designated devices. This data is subject to change without notice and revision of this document. For browser-based versions of this data sheet, refer to the left-hand navigation.

### 12.1 Tape and Reel Information

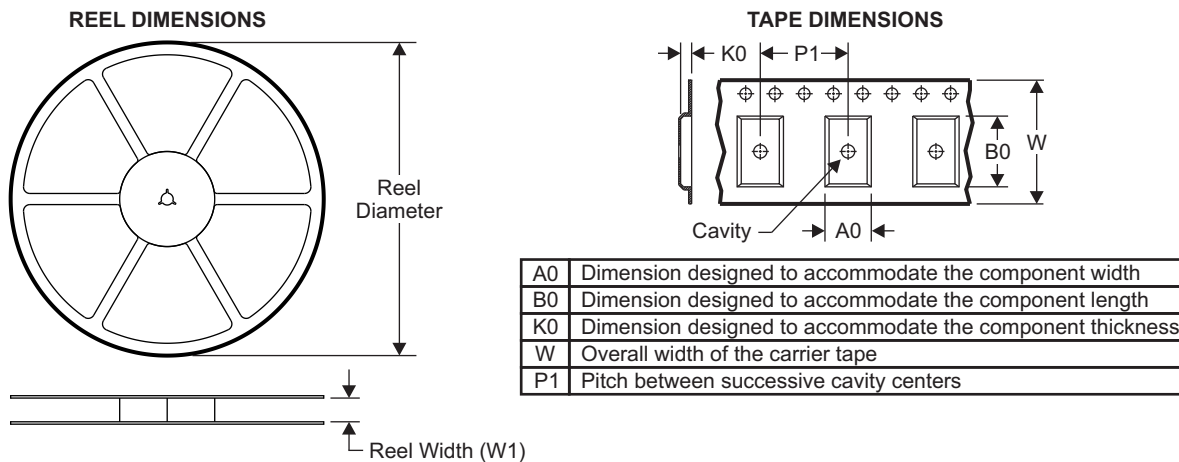

#### QUADRANT ASSIGNMENTS FOR PIN 1 ORIENTATION IN TAPE

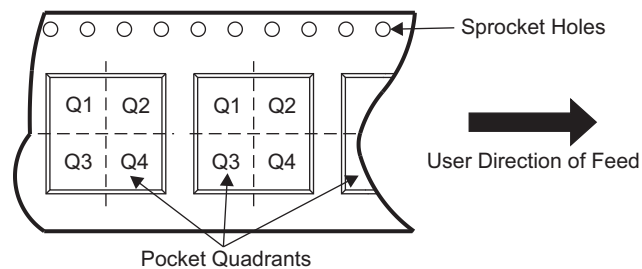

Device	Package Type	Package Drawing	Pins	SPQ	Reel Diameter (mm)	Reel Width W1 (mm)	A0 (mm)	B0 (mm)	K0 (mm)	P1 (mm)	W (mm)	Pin1 Quadrant
LMZ31707RVQR	B3QFN	RVQ	42	500	330.0	24.4	10.35	10.35	4.6	16.0	24.0	Q2
LMZ31707RVQT	B3QFN	RVQ	42	250	330.0	24.4	10.35	10.35	4.6	16.0	24.0	Q2

**TAPE AND REEL BOX DIMENSIONS**

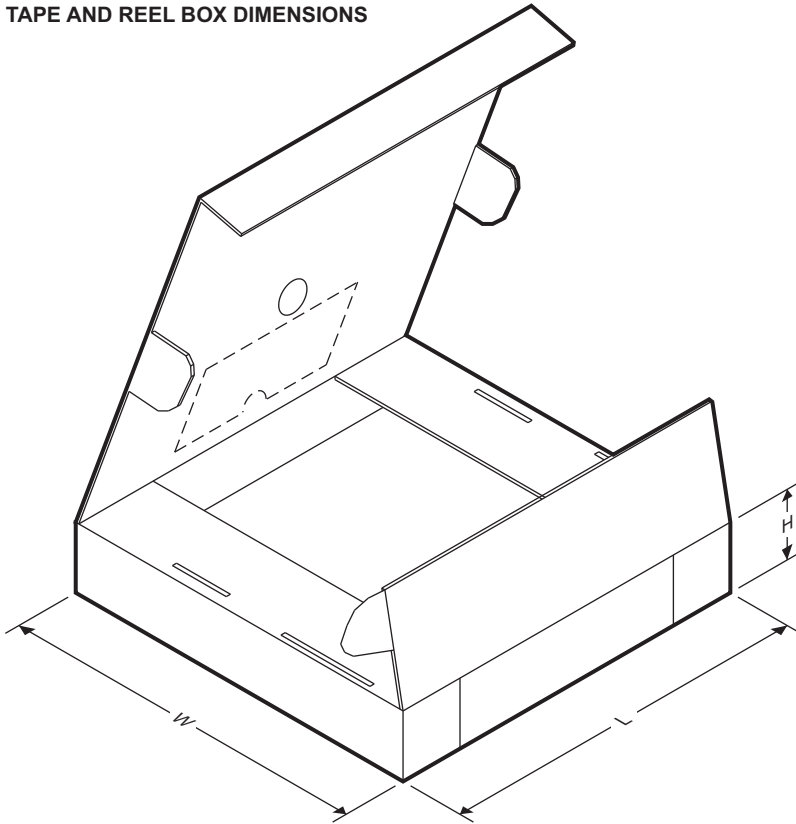

Device	Package Type	Package Drawing	Pins	SPQ	Length (mm)	Width (mm)	Height (mm)
LMZ31707RVQR	B3QFN	RVQ	42	500	383.0	353.0	58.0
LMZ31707RVQT	B3QFN	RVQ	42	250	383.0	353.0	58.0

**PACKAGING INFORMATION**

Orderable Device	Status (1)	Package Type	Package Drawing	Pins	Package Qty	Eco Plan (2)	Lead finish/ Ball material (6)	MSL Peak Temp (3)	Op Temp (°C)	Device Marking (4/5)	Samples
LMZ31707RVQR	ACTIVE	B3QFN	RVQ	42	500	RoHS Exempt & Green	NIPDAU	Level-3-245C-168 HR	-40 to 85	(54020, LMZ31707)	<a href="#">Samples</a>
LMZ31707RVQT	ACTIVE	B3QFN	RVQ	42	250	RoHS Exempt & Green	NIPDAU	Level-3-245C-168 HR	-40 to 85	(54020, LMZ31707)	<a href="#">Samples</a>

(1) The marketing status values are defined as follows:

**ACTIVE:** Product device recommended for new designs.

**LIFEBUY:** TI has announced that the device will be discontinued, and a lifetime-buy period is in effect.

**NRND:** Not recommended for new designs. Device is in production to support existing customers, but TI does not recommend using this part in a new design.

**PREVIEW:** Device has been announced but is not in production. Samples may or may not be available.

**OBSOLETE:** TI has discontinued the production of the device.

(2) **RoHS:** TI defines "RoHS" to mean semiconductor products that are compliant with the current EU RoHS requirements for all 10 RoHS substances, including the requirement that RoHS substance do not exceed 0.1% by weight in homogeneous materials. Where designed to be soldered at high temperatures, "RoHS" products are suitable for use in specified lead-free processes. TI may reference these types of products as "Pb-Free".

**RoHS Exempt:** TI defines "RoHS Exempt" to mean products that contain lead but are compliant with EU RoHS pursuant to a specific EU RoHS exemption.

**Green:** TI defines "Green" to mean the content of Chlorine (Cl) and Bromine (Br) based flame retardants meet JS709B low halogen requirements of <=1000ppm threshold. Antimony trioxide based flame retardants must also meet the <=1000ppm threshold requirement.

(3) MSL, Peak Temp. - The Moisture Sensitivity Level rating according to the JEDEC industry standard classifications, and peak solder temperature.

(4) There may be additional marking, which relates to the logo, the lot trace code information, or the environmental category on the device.

(5) Multiple Device Markings will be inside parentheses. Only one Device Marking contained in parentheses and separated by a "~" will appear on a device. If a line is indented then it is a continuation of the previous line and the two combined represent the entire Device Marking for that device.

(6) Lead finish/Ball material - Orderable Devices may have multiple material finish options. Finish options are separated by a vertical ruled line. Lead finish/Ball material values may wrap to two lines if the finish value exceeds the maximum column width.

**Important Information and Disclaimer:**The information provided on this page represents TI's knowledge and belief as of the date that it is provided. TI bases its knowledge and belief on information provided by third parties, and makes no representation or warranty as to the accuracy of such information. Efforts are underway to better integrate information from third parties. TI has taken and continues to take reasonable steps to provide representative and accurate information but may not have conducted destructive testing or chemical analysis on incoming materials and chemicals. TI and TI suppliers consider certain information to be proprietary, and thus CAS numbers and other limited information may not be available for release.

In no event shall TI's liability arising out of such information exceed the total purchase price of the TI part(s) at issue in this document sold by TI to Customer on an annual basis.



**TAPE AND REEL INFORMATION**

**QUADRANT ASSIGNMENTS FOR PIN 1 ORIENTATION IN TAPE**

\*All dimensions are nominal

Device	Package Type	Package Drawing	Pins	SPQ	Reel Diameter (mm)	Reel Width W1 (mm)	A0 (mm)	B0 (mm)	K0 (mm)	P1 (mm)	W (mm)	Pin1 Quadrant
LMZ31707RVQR	B3QFN	RVQ	42	500	330.0	24.4	10.35	10.35	4.6	16.0	24.0	Q2
LMZ31707RVQT	B3QFN	RVQ	42	250	330.0	24.4	10.35	10.35	4.6	16.0	24.0	Q2

**TAPE AND REEL BOX DIMENSIONS**

\*All dimensions are nominal

Device	Package Type	Package Drawing	Pins	SPQ	Length (mm)	Width (mm)	Height (mm)
LMZ31707RVQR	B3QFN	RVQ	42	500	383.0	353.0	58.0
LMZ31707RVQT	B3QFN	RVQ	42	250	383.0	353.0	58.0



# EXAMPLE BOARD LAYOUT

RVQ0042A

B3QFN - 4.4 mm max height

SUPER THICK QUAD FLATPACK - NO LEAD

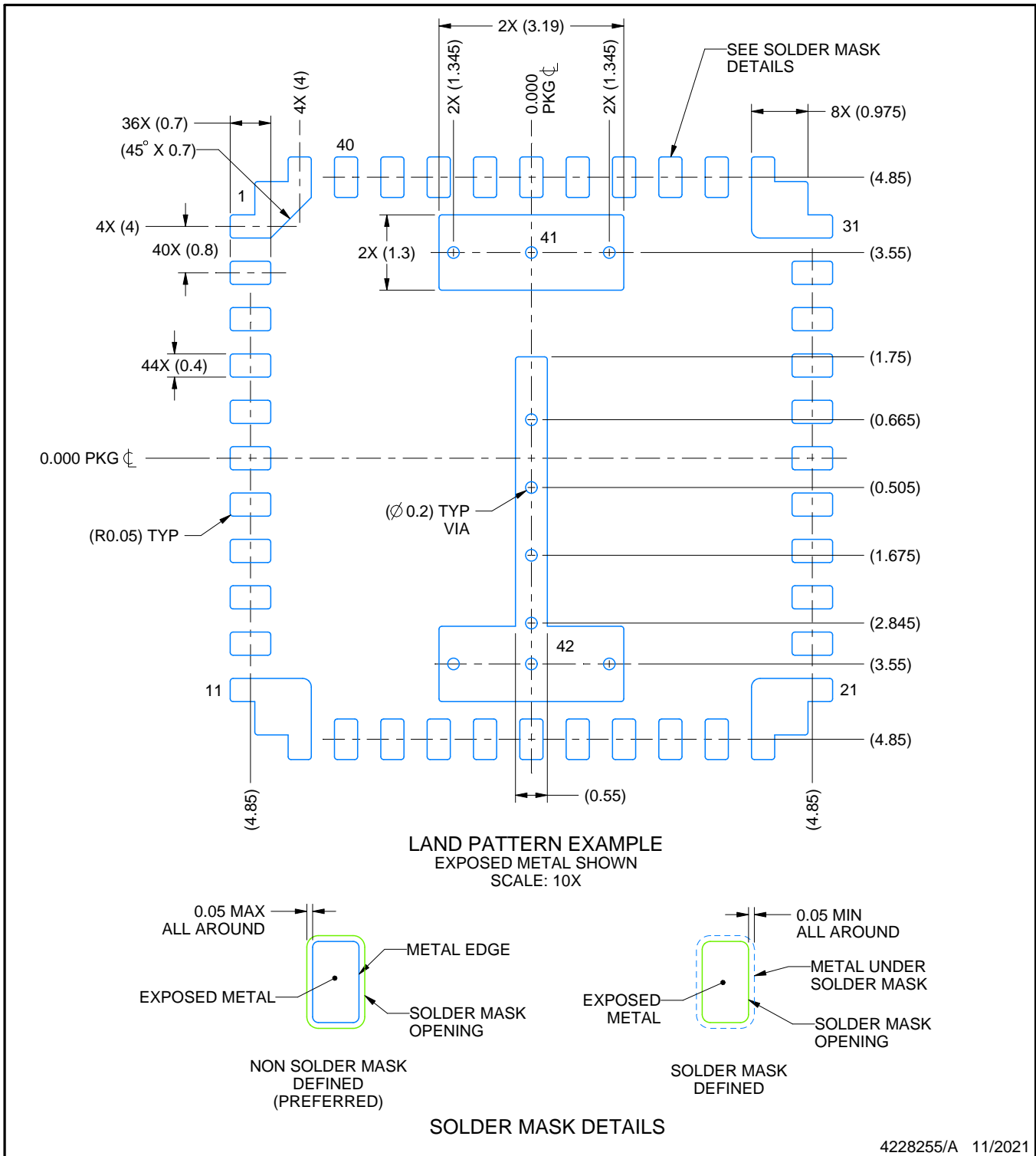

NOTES: (continued)

4. This package is designed to be soldered to a thermal pad on the board. For more information, see Texas Instruments literature number SLUA271 ([www.ti.com/lit/slua271](http://www.ti.com/lit/slua271)).
5. Vias are optional depending on application, refer to device data sheet. If any vias are implemented, refer to their locations shown on this view. It is recommended that vias under paste be filled, plugged or tented.

# EXAMPLE STENCIL DESIGN

RVQ0042A

B3QFN - 4.4 mm max height

SUPER THICK QUAD FLATPACK - NO LEAD

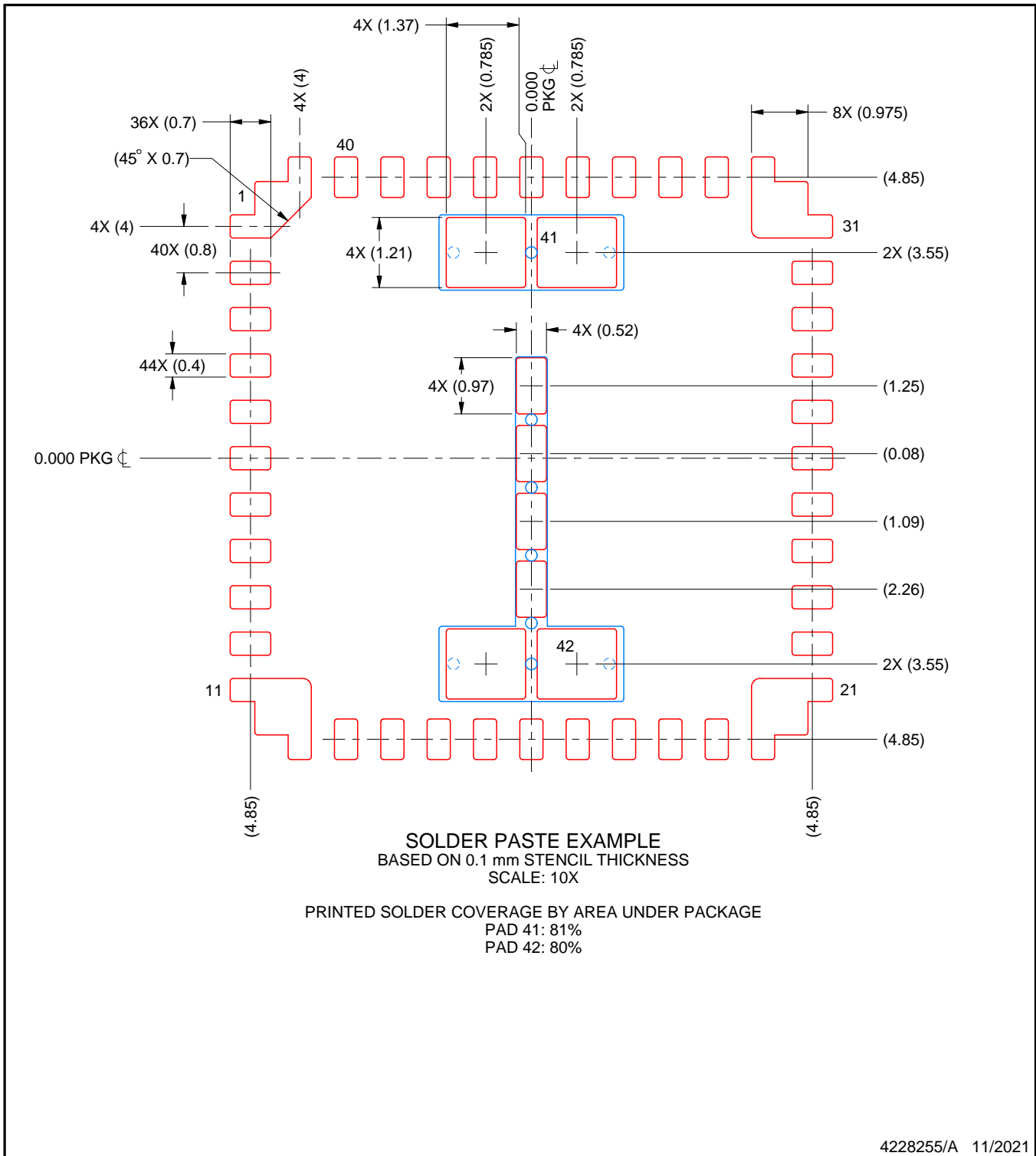

NOTES: (continued)

6. Laser cutting apertures with trapezoidal walls and rounded corners may offer better paste release. IPC-7525 may have alternate design recommendations.

## IMPORTANT NOTICE AND DISCLAIMER

TI PROVIDES TECHNICAL AND RELIABILITY DATA (INCLUDING DATA SHEETS), DESIGN RESOURCES (INCLUDING REFERENCE DESIGNS), APPLICATION OR OTHER DESIGN ADVICE, WEB TOOLS, SAFETY INFORMATION, AND OTHER RESOURCES "AS IS" AND WITH ALL FAULTS, AND DISCLAIMS ALL WARRANTIES, EXPRESS AND IMPLIED, INCLUDING WITHOUT LIMITATION ANY IMPLIED WARRANTIES OF MERCHANTABILITY, FITNESS FOR A PARTICULAR PURPOSE OR NON-INFRINGEMENT OF THIRD PARTY INTELLECTUAL PROPERTY RIGHTS.

These resources are intended for skilled developers designing with TI products. You are solely responsible for (1) selecting the appropriate TI products for your application, (2) designing, validating and testing your application, and (3) ensuring your application meets applicable standards, and any other safety, security, regulatory or other requirements.

These resources are subject to change without notice. TI grants you permission to use these resources only for development of an application that uses the TI products described in the resource. Other reproduction and display of these resources is prohibited. No license is granted to any other TI intellectual property right or to any third party intellectual property right. TI disclaims responsibility for, and you will fully indemnify TI and its representatives against, any claims, damages, costs, losses, and liabilities arising out of your use of these resources.

TI's products are provided subject to [TI's Terms of Sale](#) or other applicable terms available either on [ti.com](http://ti.com) or provided in conjunction with such TI products. TI's provision of these resources does not expand or otherwise alter TI's applicable warranties or warranty disclaimers for TI products.

TI objects to and rejects any additional or different terms you may have proposed.

Mailing Address: Texas Instruments, Post Office Box 655303, Dallas, Texas 75265  
Copyright © 2021, Texas Instruments Incorporated

## Looking for pricing, stock, or lifecycle information?

Click below to explore more details on WIN SOURCE:

 [View LMZ31707RVQR on WIN SOURCE](#)

 [Texas Instruments](#) Information

## Optimize Your Supply Chain with WIN SOURCE Solutions

-  Global Sourcing Solution
-  Obsolete Management
-  Cost Control Management
-  Shortage Management
-  Alternative Solution
-  Excess Inventory Management