



**THE DATASHEET OF  
SN74LV244ADW**



## SN74LV244A Octal Buffers and Drivers With 3-State Outputs

### 1 Features

- 2-V to 5.5-V  $V_{CC}$  Operation
- Max  $t_{pd}$  of 6.5 ns at 5 V
- Typical  $V_{OLP}$  (Output Ground Bounce)  $<0.8$  V at  $V_{CC} = 3.3$  V,  $T_A = 25^\circ\text{C}$
- Typical  $V_{OHV}$  (Output  $V_{OH}$  Undershoot)  $>2.3$  V at  $V_{CC} = 3.3$  V,  $T_A = 25^\circ\text{C}$
- Support Mixed-Mode Voltage Operation on All Ports
- $I_{off}$  Supports Partial-Power-Down Mode Operation
- Latch-Up Performance Exceeds 250-mA Per JESD 17
- ESD Protection Exceeds JESD 22
  - 2000-V Human-Body Model (A114-A)
  - 200-V Machine Model (A115-A)
  - 1000-V Charged-Device Model (C101)

### 2 Applications

- Servers and Network Switches
- LED Displays
- Telecom Infrastructure
- Motor-Drive Control Boards

### 3 Description

The SN74LV244A octal buffers and line drivers are designed for 2-V to 5.5-V  $V_{CC}$  operation.

The SN74LV244A devices are designed specifically to improve both performance and density of the 3-state memory address drivers, clock drivers, and bus-oriented receivers and transmitters. These devices are organized as two 4-bit line drivers with separate output-enable ( $\overline{OE}$ ) inputs.

#### Device Information

| PART NUMBER   | PACKAGE (PIN) | BODY SIZE          |
|---------------|---------------|--------------------|
| SN74LV244ADGV | TVSOP (20)    | 5.00 mm × 4.40 mm  |
| SN74LV244ADW  | SOIC (20)     | 12.80 mm × 7.50 mm |
| SN74LV244ANS  | SOP (20)      | 12.60 mm × 5.30 mm |
| SN74LV244APW  | TSSOP (20)    | 6.50 mm × 4.40 mm  |
| SN74LV244ARGY | VQFN (20)     | 4.50 mm × 3.50 mm  |

#### Logic Diagram (Positive Logic)

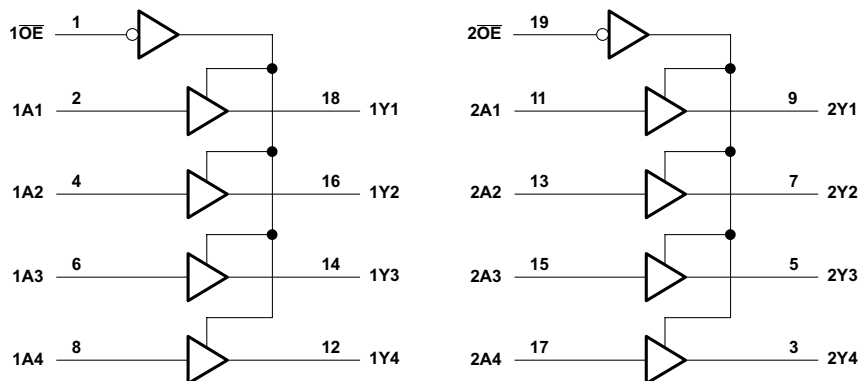

## Table of Contents

|          |                                                                           |           |           |                                                               |           |
|----------|---------------------------------------------------------------------------|-----------|-----------|---------------------------------------------------------------|-----------|
| <b>1</b> | <b>Features</b> .....                                                     | <b>1</b>  | 8.1       | Overview .....                                                | <b>10</b> |
| <b>2</b> | <b>Applications</b> .....                                                 | <b>1</b>  | 8.2       | Functional Block Diagram .....                                | <b>10</b> |
| <b>3</b> | <b>Description</b> .....                                                  | <b>1</b>  | 8.3       | Feature Description .....                                     | <b>10</b> |
| <b>4</b> | <b>Revision History</b> .....                                             | <b>2</b>  | 8.4       | Device Functional Modes .....                                 | <b>10</b> |
| <b>5</b> | <b>Pin Configuration and Functions</b> .....                              | <b>3</b>  | <b>9</b>  | <b>Application and Implementation</b> .....                   | <b>11</b> |
| <b>6</b> | <b>Specifications</b> .....                                               | <b>4</b>  | 9.1       | Application Information .....                                 | <b>11</b> |
| 6.1      | Absolute Maximum Ratings .....                                            | <b>4</b>  | 9.2       | Typical Application .....                                     | <b>11</b> |
| 6.2      | ESD Ratings .....                                                         | <b>4</b>  | <b>10</b> | <b>Power Supply Recommendations</b> .....                     | <b>13</b> |
| 6.3      | Recommended Operating Conditions .....                                    | <b>5</b>  | <b>11</b> | <b>Layout</b> .....                                           | <b>13</b> |
| 6.4      | Thermal Information .....                                                 | <b>5</b>  | 11.1      | Layout Guidelines .....                                       | <b>13</b> |
| 6.5      | Electrical Characteristics .....                                          | <b>6</b>  | 11.2      | Layout Example .....                                          | <b>13</b> |
| 6.6      | Noise Characteristics .....                                               | <b>6</b>  | <b>12</b> | <b>Device and Documentation Support</b> .....                 | <b>14</b> |
| 6.7      | Operating Characteristics .....                                           | <b>6</b>  | 12.1      | Documentation Support .....                                   | <b>14</b> |
| 6.8      | Switching Characteristics: $V_{CC} = 2.5\text{ V} \pm 0.2\text{ V}$ ..... | <b>6</b>  | 12.2      | Community Resources .....                                     | <b>14</b> |
| 6.9      | Switching Characteristics: $V_{CC} = 3.3\text{ V} \pm 0.3\text{ V}$ ..... | <b>7</b>  | 12.3      | Trademarks .....                                              | <b>14</b> |
| 6.10     | Switching Characteristics: $V_{CC} = 5\text{ V} \pm 0.5\text{ V}$ .....   | <b>7</b>  | 12.4      | Electrostatic Discharge Caution .....                         | <b>14</b> |
| 6.11     | Typical Characteristics .....                                             | <b>8</b>  | 12.5      | Glossary .....                                                | <b>14</b> |
| <b>7</b> | <b>Parameter Measurement Information</b> .....                            | <b>9</b>  | <b>13</b> | <b>Mechanical, Packaging, and Orderable Information</b> ..... | <b>14</b> |
| <b>8</b> | <b>Detailed Description</b> .....                                         | <b>10</b> |           |                                                               |           |

## 4 Revision History

NOTE: Page numbers for previous revisions may differ from page numbers in the current version.

| Changes from Revision M (June 2013) to Revision N                                                                                                                                                                                                                                                                                                                                                                    | Page     |
|----------------------------------------------------------------------------------------------------------------------------------------------------------------------------------------------------------------------------------------------------------------------------------------------------------------------------------------------------------------------------------------------------------------------|----------|
| • Added <i>Device Information</i> table, <i>Pin Functions</i> table, <i>ESD Ratings</i> table, <i>Thermal Information</i> table, <i>Detailed Description</i> section, <i>Applications and Implementation</i> section, <i>Power Supply Recommendations</i> section, <i>Layout</i> section, <i>Device and Documentation Support</i> section, and <i>Mechanical, Packaging, and Orderable Information</i> section ..... | <b>1</b> |
| • Deleted SN54LV244A part number from the data sheet .....                                                                                                                                                                                                                                                                                                                                                           | <b>1</b> |
| • Removed the $T_A = -40^\circ\text{C}$ to $85^\circ\text{C}$ test conditions with the same values as the $T_A = -40^\circ\text{C}$ to $125^\circ\text{C}$ Recommended test conditions in the <i>Electrical Characteristics</i> and <i>Switching Characteristics</i> tables .....                                                                                                                                    | <b>6</b> |
| • Removed the word 'Recommended' in the $T_A = -40^\circ\text{C}$ to $125^\circ\text{C}$ Recommended test conditions in the <i>Electrical Characteristics</i> and <i>Switching Characteristics</i> tables .....                                                                                                                                                                                                      | <b>6</b> |

| Changes from Revision L (August 2010) to Revision M                         | Page     |
|-----------------------------------------------------------------------------|----------|
| • Changed document format from Quicksilver to DocZone .....                 | <b>1</b> |
| • Changed Extended operating temperature range to $125^\circ\text{C}$ ..... | <b>1</b> |

## 5 Pin Configuration and Functions

DB, DGV, DW, NS, PW Package  
20-Pin SSOP, TVSOP, SOIC, SO, TSSOP  
Top View

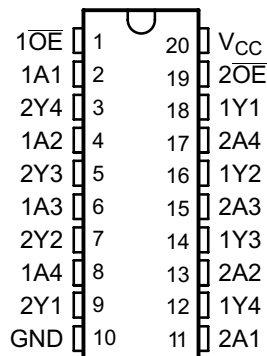

RGY Package  
20-Pin VQFN With Exposed Thermal Pad  
Top View

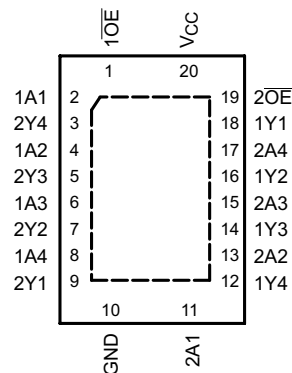

### Pin Functions

| PIN             |     | I/O | DESCRIPTION   |
|-----------------|-----|-----|---------------|
| NAME            | NO. |     |               |
| 1A1             | 2   | I   | Input         |
| 1A2             | 4   | I   | Input         |
| 1A3             | 6   | I   | Input         |
| 1A4             | 8   | I   | Input         |
| 1OE             | 1   | I   | Output enable |
| 1Y1             | 18  | O   | Output        |
| 1Y2             | 16  | O   | Output        |
| 1Y3             | 14  | O   | Output        |
| 1Y4             | 12  | O   | Output        |
| 2A1             | 11  | I   | Input         |
| 2A2             | 13  | I   | Input         |
| 2A3             | 15  | I   | Input         |
| 2A4             | 17  | I   | Input         |
| 2OE             | 19  | I   | Output enable |
| 2Y1             | 9   | O   | Output        |
| 2Y2             | 7   | O   | Output        |
| 2Y3             | 5   | O   | Output        |
| 2Y4             | 3   | O   | Output        |
| GND             | 10  | —   | Ground        |
| V <sub>CC</sub> | 20  | —   | Power pin     |

## 6 Specifications

### 6.1 Absolute Maximum Ratings

over operating free-air temperature range (unless otherwise noted)<sup>(1)</sup>

|                  |                                                                                             | MIN                                   | MAX                   | UNIT |
|------------------|---------------------------------------------------------------------------------------------|---------------------------------------|-----------------------|------|
| V <sub>CC</sub>  | Supply voltage                                                                              | –0.5                                  | 7                     | V    |
| V <sub>I</sub>   | Input voltage <sup>(2)</sup>                                                                | –0.5                                  | 7                     | V    |
| V <sub>O</sub>   | Voltage range applied to any output in the high-impedance or power-off state <sup>(2)</sup> | –0.5                                  | 7                     | V    |
| V <sub>O</sub>   | Output voltage <sup>(2)(3)</sup>                                                            | –0.5                                  | V <sub>CC</sub> + 0.5 | V    |
| I <sub>IK</sub>  | Input clamp current                                                                         | V <sub>I</sub> < 0                    | –20                   | mA   |
| I <sub>OK</sub>  | Output clamp current                                                                        | V <sub>O</sub> < 0                    | –50                   | mA   |
| I <sub>O</sub>   | Continuous output current                                                                   | V <sub>O</sub> = 0 to V <sub>CC</sub> | ±35                   | mA   |
|                  | Continuous current through V <sub>CC</sub> or GND                                           |                                       | ±70                   | mA   |
| T <sub>j</sub>   | Junction temperature                                                                        | –65                                   | 150                   | °C   |
| T <sub>stg</sub> | Storage temperature                                                                         | –65                                   | 150                   | °C   |

- (1) Stresses beyond those listed under *Absolute Maximum Ratings* may cause permanent damage to the device. These are stress ratings only, and functional operation of the device at these or any other conditions beyond those indicated under *Recommended Operating Conditions* is not implied. Exposure to absolute-maximum-rated conditions for extended periods may affect device reliability.
- (2) The input and output negative-voltage ratings may be exceeded if the input and output current ratings are observed.
- (3) This value is limited to 5.5-V maximum.

### 6.2 ESD Ratings

|                    |                         | VALUE                                                                          | UNIT |
|--------------------|-------------------------|--------------------------------------------------------------------------------|------|
| V <sub>(ESD)</sub> | Electrostatic discharge | Human body model (HBM), per ANSI/ESDA/JEDEC JS-001 <sup>(1)</sup>              | V    |
|                    |                         | Charged-device model (CDM), per JEDEC specification JESD22-C101 <sup>(2)</sup> |      |
|                    |                         | ±2000                                                                          |      |
|                    |                         | ±1000                                                                          |      |

- (1) JEDEC document JEP155 states that 500-V HBM allows safe manufacturing with a standard ESD control process.
- (2) JEDEC document JEP157 states that 250-V CDM allows safe manufacturing with a standard ESD control process.

### 6.3 Recommended Operating Conditions

 over operating free-air temperature range (unless otherwise noted)<sup>(1)</sup>

|                 |                                    | MIN                              | MAX                   | UNIT            |
|-----------------|------------------------------------|----------------------------------|-----------------------|-----------------|
| V <sub>CC</sub> | Supply voltage                     | 2                                | 5.5                   | V               |
| V <sub>IH</sub> | High-level input voltage           | V <sub>CC</sub> = 2 V            | 1.5                   | V               |
|                 |                                    | V <sub>CC</sub> = 2.3 V to 2.7 V | V <sub>CC</sub> × 0.7 |                 |
|                 |                                    | V <sub>CC</sub> = 3 V to 3.6 V   | V <sub>CC</sub> × 0.7 |                 |
|                 |                                    | V <sub>CC</sub> = 4.5 V to 5.5 V | V <sub>CC</sub> × 0.7 |                 |
| V <sub>IL</sub> | Low-level input voltage            | V <sub>CC</sub> = 2 V            | 0.5                   | V               |
|                 |                                    | V <sub>CC</sub> = 2.3 V to 2.7 V | V <sub>CC</sub> × 0.3 |                 |
|                 |                                    | V <sub>CC</sub> = 3 V to 3.6 V   | V <sub>CC</sub> × 0.3 |                 |
|                 |                                    | V <sub>CC</sub> = 4.5 V to 5.5 V | V <sub>CC</sub> × 0.3 |                 |
| V <sub>I</sub>  | Input voltage                      | 0                                | 5.5                   | V               |
| V <sub>O</sub>  | Output voltage                     | High or low state                | 0                     | V <sub>CC</sub> |
|                 |                                    | 3-state                          | 0                     | 5.5             |
| I <sub>OH</sub> | High-level output current          | V <sub>CC</sub> = 2 V            | –50                   | μA              |
|                 |                                    | V <sub>CC</sub> = 2.3 V to 2.7 V | –2                    | mA              |
|                 |                                    | V <sub>CC</sub> = 3 V to 3.6 V   | –8                    |                 |
|                 |                                    | V <sub>CC</sub> = 4.5 V to 5.5 V | –16                   |                 |
| I <sub>OL</sub> | Low-level output current           | V <sub>CC</sub> = 2 V            | 50                    | μA              |
|                 |                                    | V <sub>CC</sub> = 2.3 V to 2.7 V | 2                     | mA              |
|                 |                                    | V <sub>CC</sub> = 3 V to 3.6 V   | 8                     |                 |
|                 |                                    | V <sub>CC</sub> = 4.5 V to 5.5 V | 16                    |                 |
| Δt/Δv           | Input transition rise or fall rate | V <sub>CC</sub> = 2.3 V to 2.7 V | 200                   | ns/V            |
|                 |                                    | V <sub>CC</sub> = 3 V to 3.6 V   | 100                   |                 |
|                 |                                    | V <sub>CC</sub> = 4.5 V to 5.5 V | 20                    |                 |
| T <sub>A</sub>  | Operating free-air temperature     | –40                              | 125                   | °C              |

(1) All unused inputs of the device must be held at V<sub>CC</sub> or GND to ensure proper device operation. Refer to the TI application report, *Implications of Slow or Floating CMOS Inputs*, [SCBA004](#).

### 6.4 Thermal Information

| THERMAL METRIC <sup>(1)</sup> | SN74LV244A                                   |                |              |            |               |               | UNIT |      |
|-------------------------------|----------------------------------------------|----------------|--------------|------------|---------------|---------------|------|------|
|                               | DB<br>(SSOP)                                 | DGV<br>(TVSOP) | DW<br>(SOIC) | NS<br>(SO) | PW<br>(TSSOP) | RGY<br>(VQFN) |      |      |
|                               | 20 PINS                                      | 20 PINS        | 20 PINS      | 20 PINS    | 20 PINS       | 20 PINS       |      |      |
| R <sub>θJA</sub>              | Junction-to-ambient thermal resistance       | 94.7           | 115.9        | 79.4       | 76.9          | 102.6         | 34.9 | °C/W |
| R <sub>θJC(top)</sub>         | Junction-to-case (top) thermal resistance    | 56.7           | 31.1         | 43.8       | 43.4          | 36.7          | 43.1 | °C/W |
| R <sub>θJB</sub>              | Junction-to-board thermal resistance         | 49.9           | 57.4         | 47.2       | 44.5          | 53.6          | 12.7 | °C/W |
| ψ <sub>JT</sub>               | Junction-to-top characterization parameter   | 18.7           | 1.0          | 18.8       | 17.0          | 2.4           | 0.9  | °C/W |
| ψ <sub>JB</sub>               | Junction-to-board characterization parameter | 49.5           | 56.7         | 46.7       | 44.1          | 53.1          | 12.8 | °C/W |
| R <sub>θJC(bot)</sub>         | Junction-to-case (bottom) thermal resistance | n/a            | n/a          | n/a        | n/a           | n/a           | 7.8  | °C/W |

(1) For more information about traditional and new thermal metrics, see the *Semiconductor and IC Package Thermal Metrics* application report, [SPRA953](#).

## 6.5 Electrical Characteristics

over recommended operating free-air temperature range (unless otherwise noted)

| PARAMETER        | TEST CONDITIONS                                             |                                 | V <sub>CC</sub> | MIN                   | TYP | MAX | UNIT |
|------------------|-------------------------------------------------------------|---------------------------------|-----------------|-----------------------|-----|-----|------|
| V <sub>OH</sub>  | I <sub>OH</sub> = –50 μA                                    | T <sub>A</sub> = –40°C to 125°C | 2 V to 5.5 V    | V <sub>CC</sub> – 0.1 |     |     | V    |
|                  | I <sub>OH</sub> = –2 mA                                     | T <sub>A</sub> = –40°C to 125°C | 2.3 V           | 2                     |     |     |      |
|                  | I <sub>OH</sub> = –8 mA                                     | T <sub>A</sub> = –40°C to 125°C | 3 V             | 2.48                  |     |     |      |
|                  | I <sub>OH</sub> = 16 mA                                     | T <sub>A</sub> = –40°C to 125°C | 4.5 V           | 3.8                   |     |     |      |
| V <sub>OL</sub>  | I <sub>OL</sub> = 50 μA                                     | T <sub>A</sub> = –40°C to 125°C | 2 V to 5.5 V    | 0.1                   |     |     | V    |
|                  | I <sub>OL</sub> = 2 mA                                      | T <sub>A</sub> = –40°C to 125°C | 2.3 V           | 0.4                   |     |     |      |
|                  | I <sub>OL</sub> = 8 mA                                      | T <sub>A</sub> = –40°C to 125°C | 3 V             | 0.44                  |     |     |      |
|                  | I <sub>OL</sub> = 16 mA                                     | T <sub>A</sub> = –40°C to 125°C | 4.5 V           | 0.55                  |     |     |      |
| I <sub>I</sub>   | V <sub>I</sub> = 5.5 V or GND                               | T <sub>A</sub> = –40°C to 125°C | 0 to 5.5 V      | ±1                    |     |     | μA   |
| I <sub>OZ</sub>  | V <sub>O</sub> = V <sub>CC</sub> or GND                     | T <sub>A</sub> = –40°C to 125°C | 5.5 V           | ±5                    |     |     | μA   |
| I <sub>CC</sub>  | V <sub>I</sub> = V <sub>CC</sub> or GND, I <sub>O</sub> = 0 | T <sub>A</sub> = –40°C to 125°C | 5.5 V           | 20                    |     |     | μA   |
| I <sub>off</sub> | V <sub>I</sub> or V <sub>O</sub> = 0 to 5.5 V               | T <sub>A</sub> = –40°C to 125°C | 0               | 5                     |     |     | μA   |
| C <sub>i</sub>   | V <sub>I</sub> = V <sub>CC</sub> or GND                     | T <sub>A</sub> = –40°C to 125°C | 3.3 V           | 2.3                   |     |     | pF   |

## 6.6 Noise Characteristics

 V<sub>CC</sub> = 3.3 V, C<sub>L</sub> = 50 pF, T<sub>A</sub> = 25°C<sup>(1)</sup>

|                    |                                  | MIN  | TYP  | MAX  | UNIT |
|--------------------|----------------------------------|------|------|------|------|
| V <sub>OL(P)</sub> | Quiet output, maximum dynamic    |      | 0.55 |      | V    |
| V <sub>OL(V)</sub> | Quiet output, minimum dynamic    |      | –0.5 |      | V    |
| V <sub>OH(V)</sub> | Quiet output, minimum dynamic    |      | 2.9  |      | V    |
| V <sub>IH(D)</sub> | High-level dynamic input voltage | 2.31 |      |      | V    |
| V <sub>IL(D)</sub> | Low-level dynamic input voltage  |      |      | 0.99 | V    |

(1) Characteristics are for surface-mount packages only.

## 6.7 Operating Characteristics

 T<sub>A</sub> = 25°C

| PARAMETER                                     | TEST CONDITIONS                    | V <sub>CC</sub> | TYP | UNIT |
|-----------------------------------------------|------------------------------------|-----------------|-----|------|
| C <sub>pd</sub> Power dissipation capacitance | C <sub>L</sub> = 50 pF, f = 10 MHz | 3.3 V           | 14  | pF   |
|                                               |                                    | 5 V             | 16  |      |

## 6.8 Switching Characteristics: V<sub>CC</sub> = 2.5 V ± 0.2 V

 over recommended operating free-air temperature range (unless otherwise noted) (see [Figure 3](#))

| PARAMETER        | FROM (INPUT)           | TO (OUTPUT) | LOAD CAPACITANCE       | TEST CONDITIONS                 | MIN | TYP                | MAX                 | UNIT |
|------------------|------------------------|-------------|------------------------|---------------------------------|-----|--------------------|---------------------|------|
| t <sub>pd</sub>  | A                      | Y           | C <sub>L</sub> = 15 pF | T <sub>A</sub> = 25°C           |     | 7.5 <sup>(1)</sup> | 12.5 <sup>(1)</sup> | ns   |
|                  |                        |             |                        | T <sub>A</sub> = –40°C to 125°C | 1   |                    | 15                  |      |
| t <sub>en</sub>  | $\overline{\text{OE}}$ | Y           | C <sub>L</sub> = 15 pF | T <sub>A</sub> = 25°C           |     | 8.9 <sup>(1)</sup> | 14.6 <sup>(1)</sup> | ns   |
|                  |                        |             |                        | T <sub>A</sub> = –40°C to 125°C | 1   |                    | 17                  |      |
| t <sub>dis</sub> | $\overline{\text{OE}}$ | Y           | C <sub>L</sub> = 15 pF | T <sub>A</sub> = 25°C           |     | 9.1 <sup>(1)</sup> | 14.1 <sup>(1)</sup> | ns   |
|                  |                        |             |                        | T <sub>A</sub> = –40°C to 125°C | 1   |                    | 16                  |      |
| t <sub>pd</sub>  | A                      | Y           | C <sub>L</sub> = 50 pF | T <sub>A</sub> = 25°C           |     | 9.5 <sup>(1)</sup> | 15.3                | ns   |
|                  |                        |             |                        | T <sub>A</sub> = –40°C to 125°C | 1   |                    | 18                  |      |
| t <sub>en</sub>  | $\overline{\text{OE}}$ | Y           | C <sub>L</sub> = 50 pF | T <sub>A</sub> = 25°C           |     | 10.8               | 17.8                | ns   |
|                  |                        |             |                        | T <sub>A</sub> = –40°C to 125°C | 1   |                    | 21                  |      |

(1) On products compliant to MIL-PRF-38535, this parameter is not production tested.

**Switching Characteristics:  $V_{CC} = 2.5 V \pm 0.2 V$  (continued)**

 over recommended operating free-air temperature range (unless otherwise noted) (see [Figure 3](#))

| PARAMETER   | FROM (INPUT)    | TO (OUTPUT) | LOAD CAPACITANCE      | TEST CONDITIONS                                 | MIN | TYP  | MAX  | UNIT |
|-------------|-----------------|-------------|-----------------------|-------------------------------------------------|-----|------|------|------|
| $t_{dis}$   | $\overline{OE}$ | Y           | $C_L = 50 \text{ pF}$ | $T_A = 25^\circ\text{C}$                        |     | 13.4 | 19.2 | ns   |
|             |                 |             |                       | $T_A = -40^\circ\text{C to } 125^\circ\text{C}$ | 1   |      | 21   |      |
| $t_{sk(o)}$ |                 |             | $C_L = 50 \text{ pF}$ | $T_A = 25^\circ\text{C}$                        |     |      | 2    | ns   |
|             |                 |             |                       | $T_A = -40^\circ\text{C to } 125^\circ\text{C}$ |     |      | 2    |      |

**6.9 Switching Characteristics:  $V_{CC} = 3.3 V \pm 0.3 V$** 

 over recommended operating free-air temperature range (unless otherwise noted) (see [Figure 3](#))

| PARAMETER   | FROM (INPUT)    | TO (OUTPUT) | LOAD CAPACITANCE      | TEST CONDITIONS                                 | MIN | TYP                | MAX                 | UNIT |
|-------------|-----------------|-------------|-----------------------|-------------------------------------------------|-----|--------------------|---------------------|------|
| $t_{pd}$    | A               | Y           | $C_L = 15 \text{ pF}$ | $T_A = 25^\circ\text{C}$                        |     | 5.4 <sup>(1)</sup> | 8.4 <sup>(1)</sup>  | ns   |
|             |                 |             |                       | $T_A = -40^\circ\text{C to } 125^\circ\text{C}$ | 1   |                    | 10                  |      |
| $t_{en}$    | $\overline{OE}$ | Y           | $C_L = 15 \text{ pF}$ | $T_A = 25^\circ\text{C}$                        |     | 6.3 <sup>(1)</sup> | 10.6 <sup>(1)</sup> | ns   |
|             |                 |             |                       | $T_A = -40^\circ\text{C to } 125^\circ\text{C}$ | 1   |                    | 12.5                |      |
| $t_{dis}$   | $\overline{OE}$ | Y           | $C_L = 15 \text{ pF}$ | $T_A = 25^\circ\text{C}$                        |     | 7.6 <sup>(1)</sup> | 11.7 <sup>(1)</sup> | ns   |
|             |                 |             |                       | $T_A = -40^\circ\text{C to } 125^\circ\text{C}$ | 1   |                    | 13                  |      |
| $t_{pd}$    | A               | Y           | $C_L = 50 \text{ pF}$ | $T_A = 25^\circ\text{C}$                        |     | 6.8                | 11.9                | ns   |
|             |                 |             |                       | $T_A = -40^\circ\text{C to } 125^\circ\text{C}$ | 1   |                    | 13.5                |      |
| $t_{en}$    | $\overline{OE}$ | Y           | $C_L = 50 \text{ pF}$ | $T_A = 25^\circ\text{C}$                        |     | 7.8                | 14.1                | ns   |
|             |                 |             |                       | $T_A = -40^\circ\text{C to } 125^\circ\text{C}$ | 1   |                    | 16                  |      |
| $t_{dis}$   | $\overline{OE}$ | Y           | $C_L = 50 \text{ pF}$ | $T_A = 25^\circ\text{C}$                        |     | 11                 | 16                  | ns   |
|             |                 |             |                       | $T_A = -40^\circ\text{C to } 125^\circ\text{C}$ | 1   |                    | 18                  |      |
| $t_{sk(o)}$ |                 |             | $C_L = 50 \text{ pF}$ | $T_A = 25^\circ\text{C}$                        |     |                    | 1.5                 | ns   |
|             |                 |             |                       | $T_A = -40^\circ\text{C to } 125^\circ\text{C}$ |     |                    | 1.5                 |      |

(1) On products compliant to MIL-PRF-38535, this parameter is not production tested.

**6.10 Switching Characteristics:  $V_{CC} = 5 V \pm 0.5 V$** 

 over recommended operating free-air temperature range (unless otherwise noted) (see [Figure 3](#))

| PARAMETER   | FROM (INPUT)    | TO (OUTPUT) | LOAD CAPACITANCE      | TEST CONDITIONS                                 | MIN | TYP                | MAX                 | UNIT |
|-------------|-----------------|-------------|-----------------------|-------------------------------------------------|-----|--------------------|---------------------|------|
| $t_{pd}$    | A               | Y           | $C_L = 15 \text{ pF}$ | $T_A = 25^\circ\text{C}$                        |     | 3.9 <sup>(1)</sup> | 5.5 <sup>(1)</sup>  | ns   |
|             |                 |             |                       | $T_A = -40^\circ\text{C to } 125^\circ\text{C}$ | 1   |                    | 6.5                 |      |
| $t_{en}$    | $\overline{OE}$ | Y           | $C_L = 15 \text{ pF}$ | $T_A = 25^\circ\text{C}$                        |     | 4.5 <sup>(1)</sup> | 7.3 <sup>(1)</sup>  | ns   |
|             |                 |             |                       | $T_A = -40^\circ\text{C to } 125^\circ\text{C}$ | 1   |                    | 8.5                 |      |
| $t_{dis}$   | $\overline{OE}$ | Y           | $C_L = 15 \text{ pF}$ | $T_A = 25^\circ\text{C}$                        |     | 6.5 <sup>(1)</sup> | 12.2 <sup>(1)</sup> | ns   |
|             |                 |             |                       | $T_A = -40^\circ\text{C to } 125^\circ\text{C}$ | 1   |                    | 13.5                |      |
| $t_{pd}$    | A               | Y           | $C_L = 50 \text{ pF}$ | $T_A = 25^\circ\text{C}$                        |     | 4.9                | 7.5                 | ns   |
|             |                 |             |                       | $T_A = -40^\circ\text{C to } 125^\circ\text{C}$ | 1   |                    | 8.5                 |      |
| $t_{en}$    | $\overline{OE}$ | Y           | $C_L = 50 \text{ pF}$ | $T_A = 25^\circ\text{C}$                        |     | 5.6                | 9.3                 | ns   |
|             |                 |             |                       | $T_A = -40^\circ\text{C to } 125^\circ\text{C}$ | 1   |                    | 10.5                |      |
| $t_{dis}$   | $\overline{OE}$ | Y           | $C_L = 50 \text{ pF}$ | $T_A = 25^\circ\text{C}$                        |     | 8.8                | 14.2                | ns   |
|             |                 |             |                       | $T_A = -40^\circ\text{C to } 125^\circ\text{C}$ | 1   |                    | 15.5                |      |
| $t_{sk(o)}$ |                 |             |                       | $T_A = 25^\circ\text{C}$                        |     |                    | 1                   | ns   |
|             |                 |             |                       | $T_A = -40^\circ\text{C to } 85^\circ\text{C}$  |     |                    | 1                   |      |

(1) On products compliant to MIL-PRF-38535, this parameter is not production tested.

### 6.11 Typical Characteristics

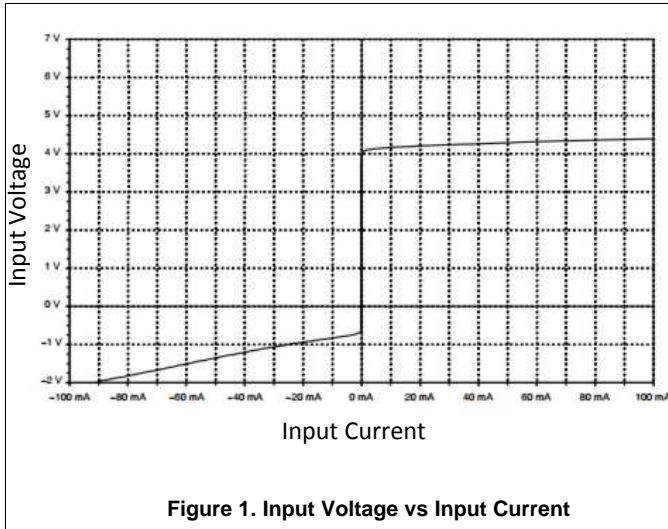

Figure 1. Input Voltage vs Input Current

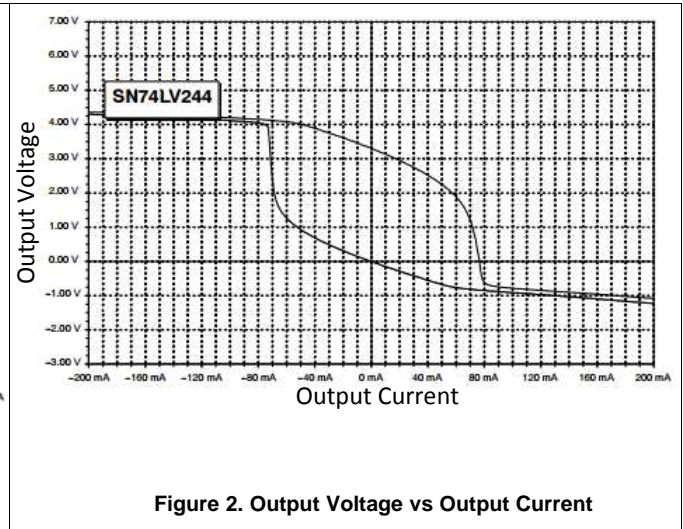
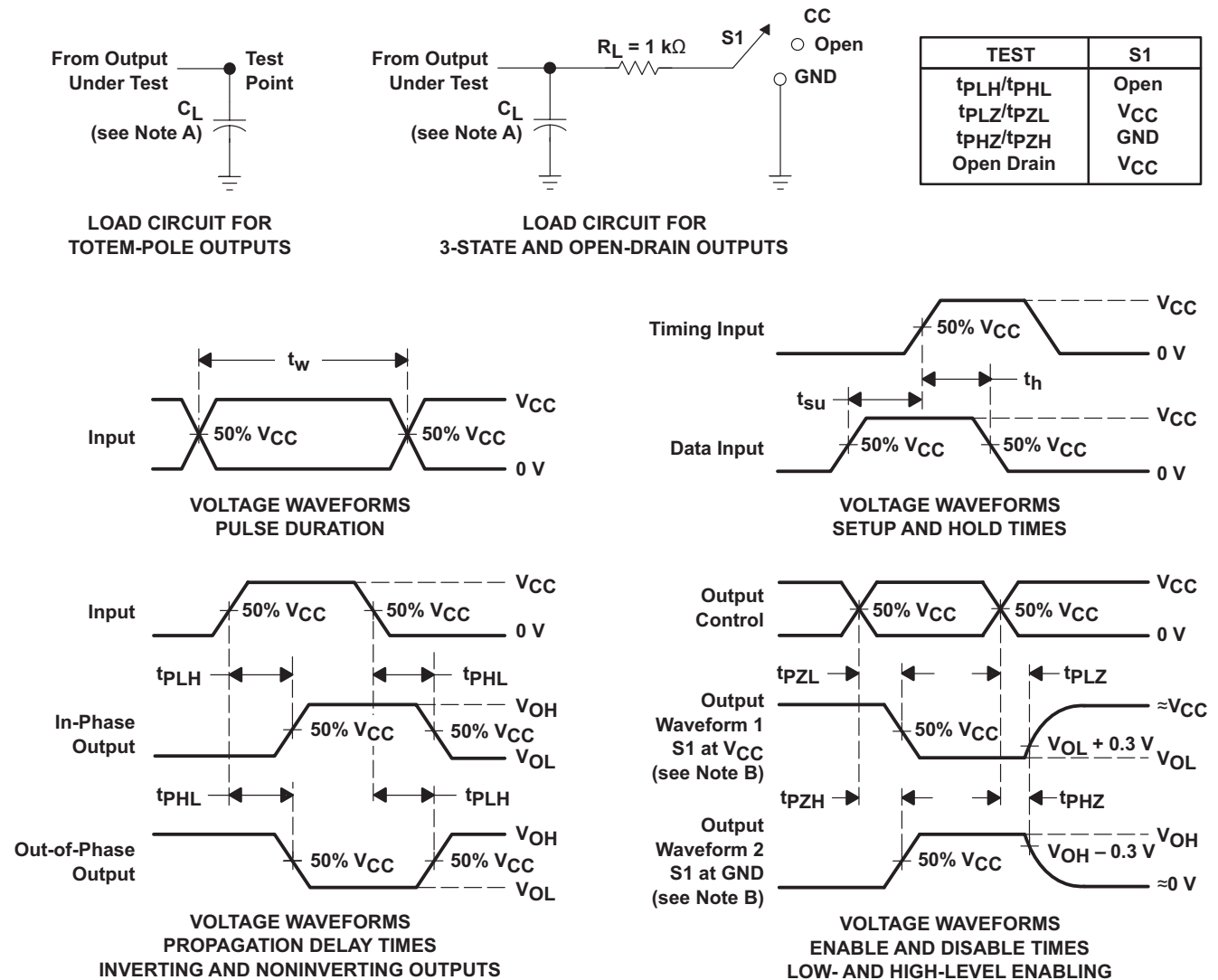

Figure 2. Output Voltage vs Output Current

## 7 Parameter Measurement Information



- A.  $C_L$  includes probe and jig capacitance.
- B. Waveform 1 is for an output with internal conditions such that the output is low, except when disabled by the output control. Waveform 2 is for an output with internal conditions such that the output is high, except when disabled by the output control.
- C. All input pulses are supplied by generators having the following characteristics:  $PRR \leq 1\text{ MHz}$ ,  $Z_O = 50\ \Omega$ ,  $t_r \leq 3\text{ ns}$ ,  $t_f \leq 3\text{ ns}$ .
- D. The outputs are measured one at a time, with one input transition per measurement.
- E.  $t_{PLZ}$  and  $t_{PHZ}$  are the same as  $t_{dis}$ .
- F.  $t_{PZL}$  and  $t_{PZH}$  are the same as  $t_{en}$ .
- G.  $t_{PHL}$  and  $t_{PLH}$  are the same as  $t_{pd}$ .
- H. All parameters and waveforms are not applicable to all devices.

Figure 3. Load Circuit and Voltage Waveforms

## 8 Detailed Description

### 8.1 Overview

The SN74LV244 devices are octal buffers grouped in fours, with each group having its own enable pin. The LV family supports high current drive of about 16 mA, thus making it suitable for driving digital signals over longer board lengths. This device is generally used to buffer or incorporate delays between the signals between two microcontroller or peripheral devices.

### 8.2 Functional Block Diagram

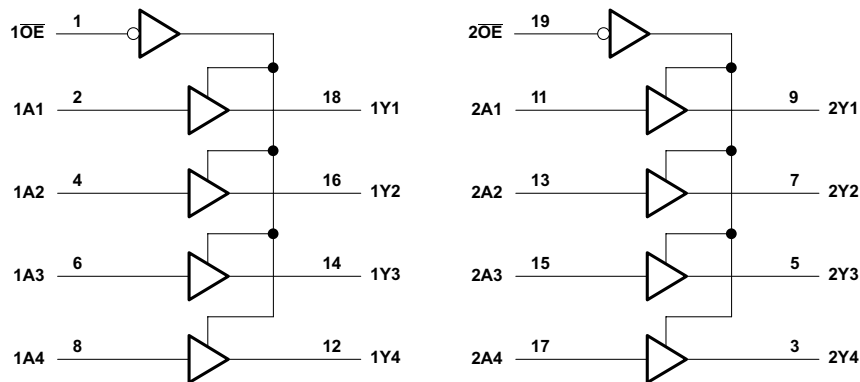

### 8.3 Feature Description

The SN74LV244A, a part of LV family, can work over a wide voltage range from 2 V to 5.5 V. The device features a very low propagation delay of about 6.5 ns when enabled for 5-V  $V_{CC}$ , which allows the device to be used for high-speed applications. The device supports a partial-power-down mode for low quiescent current application, thus making it the buffer of choice in power-efficient circuits. The  $I_{off}$  circuitry also disables the outputs, preventing damaging current backflow through the devices when they are powered down.

### 8.4 Device Functional Modes

The SN74LV244A devices are organized as two 4-bit line drivers with separate output-enable ( $\overline{OE}$ ) inputs. When  $\overline{OE}$  is low, the device passes data from the A inputs to the Y outputs. When  $\overline{OE}$  is high, the outputs are in the high-impedance state. To ensure the high-impedance state during power up or power down,  $\overline{OE}$  must be tied to  $V_{CC}$  through a pullup resistor; the minimum value of the resistor is determined by the current-sinking capability of the driver.

**Table 1. Function Table**

| INPUTS          |   | OUTPUTS |  |
|-----------------|---|---------|--|
| $\overline{OE}$ | A | Y       |  |
| L               | L | L       |  |
| L               | H | H       |  |
| H               | X | Z       |  |

## 9 Application and Implementation

### NOTE

Information in the following applications sections is not part of the TI component specification, and TI does not warrant its accuracy or completeness. TI's customers are responsible for determining suitability of components for their purposes. Customers should validate and test their design implementation to confirm system functionality.

### 9.1 Application Information

The SN74LV244A device can be used as an 8-channel buffer to drive signals from one controller to another device. Buffers are typically used for signals running on long traces on printed circuit boards or going through connectors linking two printed circuit boards together. Buffers are also used to create delay between the lines to match the edges of two clock or data signals. The high-current capability of the SN74LV244A device also allows a controller to drive LEDs up to 16 mA.

### 9.2 Typical Application

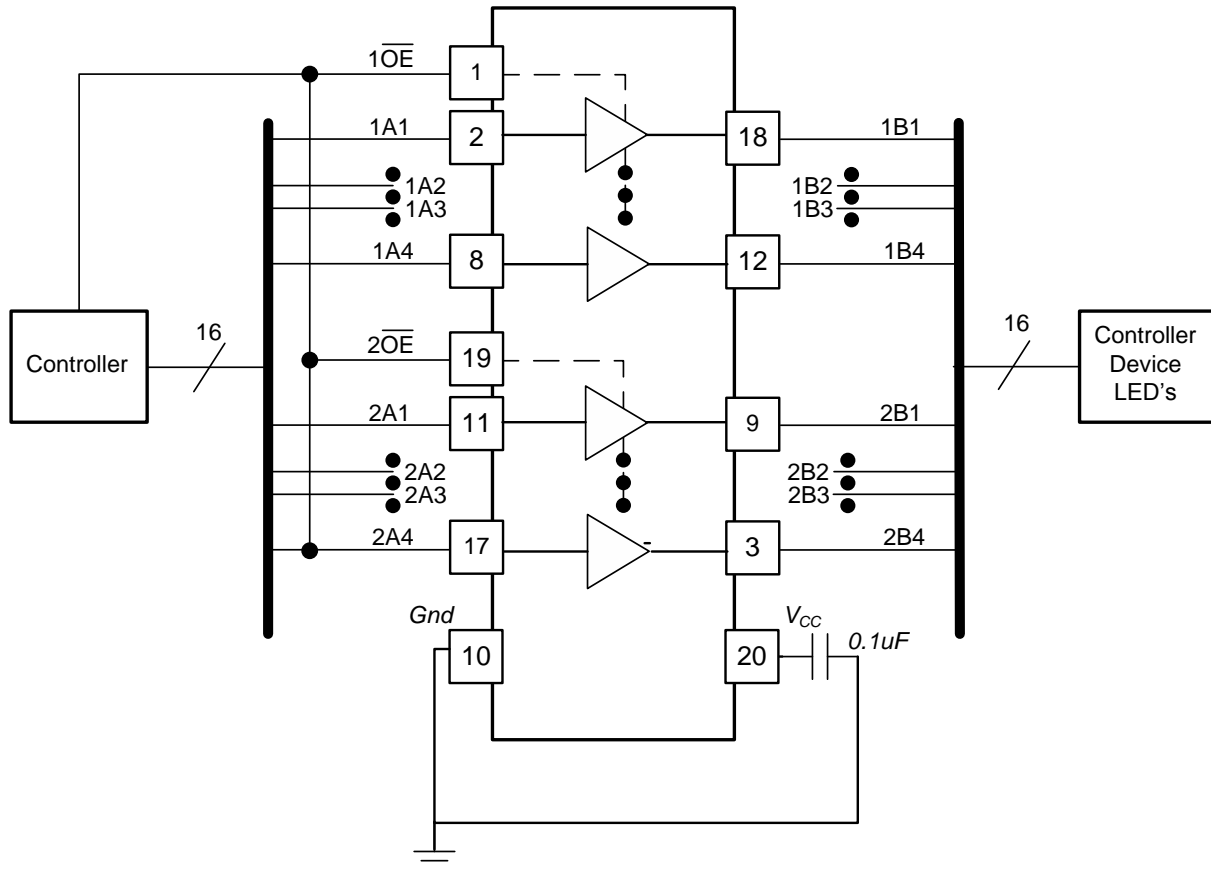

Figure 4. Typical Application Diagram

## Typical Application (continued)

### 9.2.1 Design Requirements

A 0.1- $\mu$ F bypass capacitor must be placed between each  $V_{CC}$  pin and GND. For best results, each capacitor must be placed as close as possible to the SN74LV244A device.

### 9.2.2 Detailed Design Procedure

1. Recommended input conditions:
  - For specified high and low levels, see  $V_{IH}$  and  $V_{IL}$  in [Recommended Operating Conditions](#)
  - Inputs and outputs are overvoltage tolerant, which allows them to go as high as 5.5 V at any valid  $V_{CC}$
2. Recommended output conditions:
  - Load currents must not exceed limits as mentioned in [Recommended Operating Conditions](#)
3. Frequency selection criterion:
  - Added trace resistance or capacitance can reduce maximum frequency capability; use layout practices as directed in [Layout Guidelines](#)

### 9.2.3 Application Curve

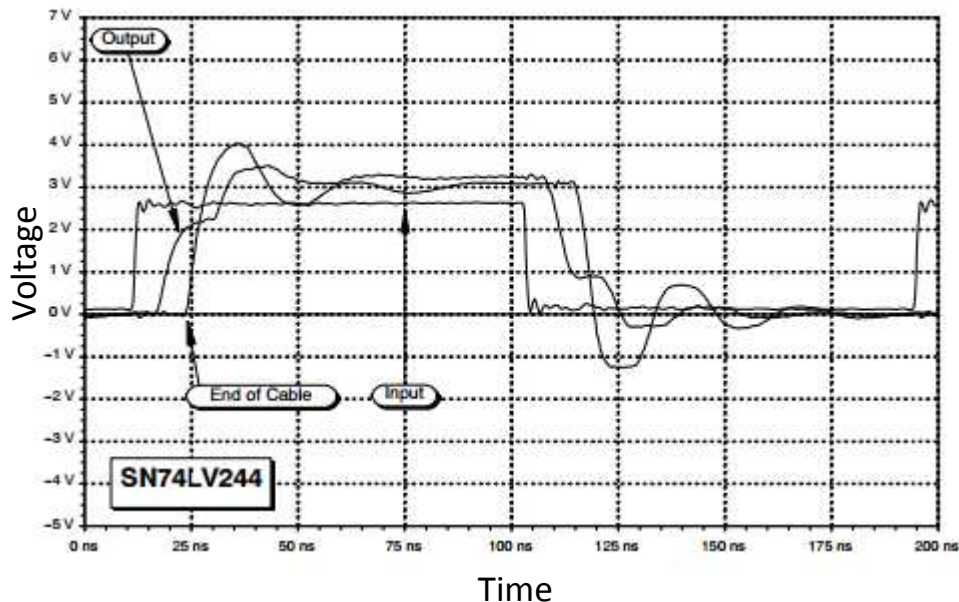

Figure 5. SN74LV244A Transient response

## 10 Power Supply Recommendations

The power supply can be any voltage between the minimum and maximum supply-voltage rating listed in the [Absolute Maximum Ratings](#) table.

Each  $V_{CC}$  terminal must have a good bypass capacitor to prevent power disturbance. For devices with a single supply, a 0.1- $\mu\text{F}$  bypass capacitor is recommended. If multiple pins are labeled  $V_{CC}$ , then a 0.01- $\mu\text{F}$  or 0.022- $\mu\text{F}$  capacitor is recommended for each  $V_{CC}$  because the  $V_{CC}$  pins are tied together internally. For devices with dual-supply pins operating at different voltages, for example  $V_{CC}$  and  $V_{DD}$ , a 0.1- $\mu\text{F}$  bypass capacitor is recommended for each supply pin. To reject different frequencies of noise, use multiple bypass capacitors in parallel. Capacitors with values of 0.1  $\mu\text{F}$  and 1  $\mu\text{F}$  are commonly used in parallel. For best results, the bypass capacitor must be installed as close as possible to the power terminal.

## 11 Layout

### 11.1 Layout Guidelines

Reflections and matching are closely related to the loop antenna theory but are different enough to be discussed separately from the theory. When a PCB trace turns a corner at a 90° angle, a reflection can occur. A reflection occurs primarily because of the change of width of the trace. At the apex of the turn, the trace width increases to 1.414 times the width. This increase upsets the transmission-line characteristics, especially the distributed capacitance and self-inductance of the trace, which results in the reflection. Not all PCB traces can be straight; therefore, some traces must turn corners. [Figure 6](#) shows progressively better techniques of rounding corners. Only the last example (BEST) maintains constant trace width and minimizes reflections.

### 11.2 Layout Example

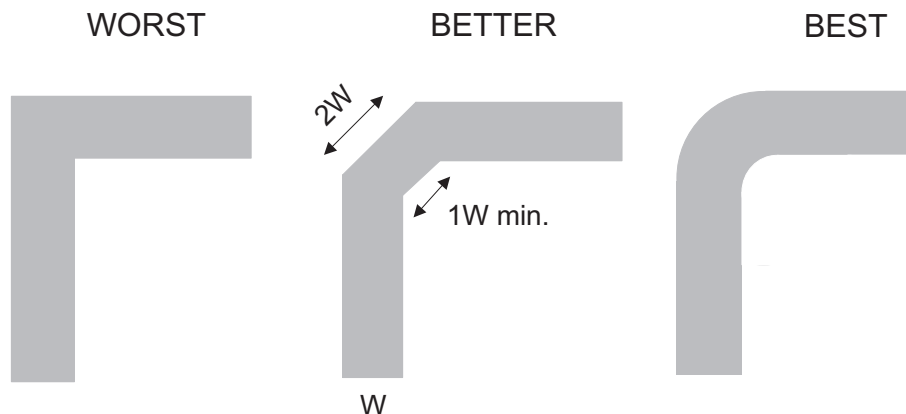

Figure 6. Trace Example

## 12 Device and Documentation Support

### 12.1 Documentation Support

#### 12.1.1 Related Documentation

For related documentation, see the following:

*Implications of Slow or Floating CMOS Inputs*, [SCBA004](#)

### 12.2 Community Resources

The following links connect to TI community resources. Linked contents are provided "AS IS" by the respective contributors. They do not constitute TI specifications and do not necessarily reflect TI's views; see TI's [Terms of Use](#).

**TI E2E™ Online Community** *TI's Engineer-to-Engineer (E2E) Community*. Created to foster collaboration among engineers. At [e2e.ti.com](#), you can ask questions, share knowledge, explore ideas and help solve problems with fellow engineers.

**Design Support** *TI's Design Support* Quickly find helpful E2E forums along with design support tools and contact information for technical support.

### 12.3 Trademarks

E2E is a trademark of Texas Instruments.

All other trademarks are the property of their respective owners.

### 12.4 Electrostatic Discharge Caution



These devices have limited built-in ESD protection. The leads should be shorted together or the device placed in conductive foam during storage or handling to prevent electrostatic damage to the MOS gates.

### 12.5 Glossary

[SLYZ022](#) — *TI Glossary*.

This glossary lists and explains terms, acronyms, and definitions.

## 13 Mechanical, Packaging, and Orderable Information

The following pages include mechanical, packaging, and orderable information. This information is the most current data available for the designated devices. This data is subject to change without notice and revision of this document. For browser-based versions of this data sheet, refer to the left-hand navigation.

**PACKAGING INFORMATION**

| Orderable Device | Status<br>(1) | Package Type | Package Drawing | Pins | Package Qty | Eco Plan<br>(2)         | Lead/Ball Finish<br>(6) | MSL Peak Temp<br>(3) | Op Temp (°C) | Device Marking<br>(4/5) | Samples                 |
|------------------|---------------|--------------|-----------------|------|-------------|-------------------------|-------------------------|----------------------|--------------|-------------------------|-------------------------|
| SN74LV244ADBR    | ACTIVE        | SSOP         | DB              | 20   | 2000        | Green (RoHS & no Sb/Br) | CU NIPDAU               | Level-1-260C-UNLIM   | -40 to 125   | LV244A                  | <a href="#">Samples</a> |
| SN74LV244ADBRE4  | ACTIVE        | SSOP         | DB              | 20   | 2000        | Green (RoHS & no Sb/Br) | CU NIPDAU               | Level-1-260C-UNLIM   | -40 to 125   | LV244A                  | <a href="#">Samples</a> |
| SN74LV244ADBRG4  | ACTIVE        | SSOP         | DB              | 20   | 2000        | Green (RoHS & no Sb/Br) | CU NIPDAU               | Level-1-260C-UNLIM   | -40 to 125   | LV244A                  | <a href="#">Samples</a> |
| SN74LV244ADGVR   | ACTIVE        | TVSOP        | DGV             | 20   | 2000        | Green (RoHS & no Sb/Br) | CU NIPDAU               | Level-1-260C-UNLIM   | -40 to 125   | LV244A                  | <a href="#">Samples</a> |
| SN74LV244ADW     | ACTIVE        | SOIC         | DW              | 20   | 25          | Green (RoHS & no Sb/Br) | CU NIPDAU               | Level-1-260C-UNLIM   | -40 to 125   | LV244A                  | <a href="#">Samples</a> |
| SN74LV244ADWE4   | ACTIVE        | SOIC         | DW              | 20   | 25          | Green (RoHS & no Sb/Br) | CU NIPDAU               | Level-1-260C-UNLIM   | -40 to 125   | LV244A                  | <a href="#">Samples</a> |
| SN74LV244ADWG4   | ACTIVE        | SOIC         | DW              | 20   | 25          | Green (RoHS & no Sb/Br) | CU NIPDAU               | Level-1-260C-UNLIM   | -40 to 125   | LV244A                  | <a href="#">Samples</a> |
| SN74LV244ADWR    | ACTIVE        | SOIC         | DW              | 20   | 2000        | Green (RoHS & no Sb/Br) | CU NIPDAU               | Level-1-260C-UNLIM   | -40 to 125   | LV244A                  | <a href="#">Samples</a> |
| SN74LV244ADWRG4  | ACTIVE        | SOIC         | DW              | 20   | 2000        | Green (RoHS & no Sb/Br) | CU NIPDAU               | Level-1-260C-UNLIM   | -40 to 125   | LV244A                  | <a href="#">Samples</a> |
| SN74LV244ANSR    | ACTIVE        | SO           | NS              | 20   | 2000        | Green (RoHS & no Sb/Br) | CU NIPDAU               | Level-1-260C-UNLIM   | -40 to 125   | 74LV244A                | <a href="#">Samples</a> |
| SN74LV244APW     | ACTIVE        | TSSOP        | PW              | 20   | 70          | Green (RoHS & no Sb/Br) | CU NIPDAU               | Level-1-260C-UNLIM   | -40 to 125   | LV244A                  | <a href="#">Samples</a> |
| SN74LV244APWG4   | ACTIVE        | TSSOP        | PW              | 20   | 70          | Green (RoHS & no Sb/Br) | CU NIPDAU               | Level-1-260C-UNLIM   | -40 to 125   | LV244A                  | <a href="#">Samples</a> |
| SN74LV244APWR    | ACTIVE        | TSSOP        | PW              | 20   | 2000        | Green (RoHS & no Sb/Br) | CU NIPDAU   CU SN       | Level-1-260C-UNLIM   | -40 to 125   | LV244A                  | <a href="#">Samples</a> |
| SN74LV244APWRE4  | ACTIVE        | TSSOP        | PW              | 20   | 2000        | Green (RoHS & no Sb/Br) | CU NIPDAU               | Level-1-260C-UNLIM   | -40 to 125   | LV244A                  | <a href="#">Samples</a> |
| SN74LV244APWRG3  | ACTIVE        | TSSOP        | PW              | 20   | 2000        | Green (RoHS & no Sb/Br) | CU SN                   | Level-1-260C-UNLIM   | -40 to 125   | LV244A                  | <a href="#">Samples</a> |
| SN74LV244APWRG4  | ACTIVE        | TSSOP        | PW              | 20   | 2000        | Green (RoHS & no Sb/Br) | CU NIPDAU               | Level-1-260C-UNLIM   | -40 to 125   | LV244A                  | <a href="#">Samples</a> |
| SN74LV244APWT    | ACTIVE        | TSSOP        | PW              | 20   | 250         | Green (RoHS & no Sb/Br) | CU NIPDAU               | Level-1-260C-UNLIM   | -40 to 125   | LV244A                  | <a href="#">Samples</a> |

| Orderable Device | Status<br>(1) | Package Type | Package<br>Drawing | Pins | Package<br>Qty | Eco Plan<br>(2)            | Lead/Ball Finish<br>(6) | MSL Peak Temp<br>(3) | Op Temp (°C) | Device Marking<br>(4/5) | Samples        |
|------------------|---------------|--------------|--------------------|------|----------------|----------------------------|-------------------------|----------------------|--------------|-------------------------|----------------|
| SN74LV244ARGYR   | ACTIVE        | VQFN         | RGY                | 20   | 3000           | Green (RoHS<br>& no Sb/Br) | CU NIPDAU               | Level-2-260C-1 YEAR  | -40 to 125   | LV244A                  | <b>Samples</b> |

(1) The marketing status values are defined as follows:

**ACTIVE:** Product device recommended for new designs.

**LIFEBUY:** TI has announced that the device will be discontinued, and a lifetime-buy period is in effect.

**NRND:** Not recommended for new designs. Device is in production to support existing customers, but TI does not recommend using this part in a new design.

**PREVIEW:** Device has been announced but is not in production. Samples may or may not be available.

**OBSOLETE:** TI has discontinued the production of the device.

(2) Eco Plan - The planned eco-friendly classification: Pb-Free (RoHS), Pb-Free (RoHS Exempt), or Green (RoHS & no Sb/Br) - please check <http://www.ti.com/productcontent> for the latest availability information and additional product content details.

**TBD:** The Pb-Free/Green conversion plan has not been defined.

**Pb-Free (RoHS):** TI's terms "Lead-Free" or "Pb-Free" mean semiconductor products that are compatible with the current RoHS requirements for all 6 substances, including the requirement that lead not exceed 0.1% by weight in homogeneous materials. Where designed to be soldered at high temperatures, TI Pb-Free products are suitable for use in specified lead-free processes.

**Pb-Free (RoHS Exempt):** This component has a RoHS exemption for either 1) lead-based flip-chip solder bumps used between the die and package, or 2) lead-based die adhesive used between the die and leadframe. The component is otherwise considered Pb-Free (RoHS compatible) as defined above.

**Green (RoHS & no Sb/Br):** TI defines "Green" to mean Pb-Free (RoHS compatible), and free of Bromine (Br) and Antimony (Sb) based flame retardants (Br or Sb do not exceed 0.1% by weight in homogeneous material)

(3) MSL, Peak Temp. - The Moisture Sensitivity Level rating according to the JEDEC industry standard classifications, and peak solder temperature.

(4) There may be additional marking, which relates to the logo, the lot trace code information, or the environmental category on the device.

(5) Multiple Device Markings will be inside parentheses. Only one Device Marking contained in parentheses and separated by a "~" will appear on a device. If a line is indented then it is a continuation of the previous line and the two combined represent the entire Device Marking for that device.

(6) Lead/Ball Finish - Orderable Devices may have multiple material finish options. Finish options are separated by a vertical ruled line. Lead/Ball Finish values may wrap to two lines if the finish value exceeds the maximum column width.

**Important Information and Disclaimer:** The information provided on this page represents TI's knowledge and belief as of the date that it is provided. TI bases its knowledge and belief on information provided by third parties, and makes no representation or warranty as to the accuracy of such information. Efforts are underway to better integrate information from third parties. TI has taken and continues to take reasonable steps to provide representative and accurate information but may not have conducted destructive testing or chemical analysis on incoming materials and chemicals. TI and TI suppliers consider certain information to be proprietary, and thus CAS numbers and other limited information may not be available for release.

In no event shall TI's liability arising out of such information exceed the total purchase price of the TI part(s) at issue in this document sold by TI to Customer on an annual basis.

**OTHER QUALIFIED VERSIONS OF SN74LV244A :**

- Enhanced Product: [SN74LV244A-EP](#)

NOTE: Qualified Version Definitions:

- Enhanced Product - Supports Defense, Aerospace and Medical Applications

## TAPE AND REEL INFORMATION



### QUADRANT ASSIGNMENTS FOR PIN 1 ORIENTATION IN TAPE



\*All dimensions are nominal

| Device          | Package Type | Package Drawing | Pins | SPQ  | Reel Diameter (mm) | Reel Width W1 (mm) | A0 (mm) | B0 (mm) | K0 (mm) | P1 (mm) | W (mm) | Pin1 Quadrant |
|-----------------|--------------|-----------------|------|------|--------------------|--------------------|---------|---------|---------|---------|--------|---------------|
| SN74LV244ADBR   | SSOP         | DB              | 20   | 2000 | 330.0              | 16.4               | 8.2     | 7.5     | 2.5     | 12.0    | 16.0   | Q1            |
| SN74LV244ADGVR  | TVSOP        | DGV             | 20   | 2000 | 330.0              | 12.4               | 6.9     | 5.6     | 1.6     | 8.0     | 12.0   | Q1            |
| SN74LV244ADWR   | SOIC         | DW              | 20   | 2000 | 330.0              | 24.4               | 10.8    | 13.3    | 2.7     | 12.0    | 24.0   | Q1            |
| SN74LV244ANSR   | SO           | NS              | 20   | 2000 | 330.0              | 24.4               | 8.4     | 13.0    | 2.5     | 12.0    | 24.0   | Q1            |
| SN74LV244APWR   | TSSOP        | PW              | 20   | 2000 | 330.0              | 16.4               | 6.95    | 7.1     | 1.6     | 8.0     | 16.0   | Q1            |
| SN74LV244APWRG3 | TSSOP        | PW              | 20   | 2000 | 330.0              | 16.4               | 6.95    | 7.1     | 1.6     | 8.0     | 16.0   | Q1            |
| SN74LV244APWT   | TSSOP        | PW              | 20   | 250  | 330.0              | 16.4               | 6.95    | 7.1     | 1.6     | 8.0     | 16.0   | Q1            |
| SN74LV244ARGYR  | VQFN         | RGY             | 20   | 3000 | 330.0              | 12.4               | 3.8     | 4.8     | 1.6     | 8.0     | 12.0   | Q1            |

**TAPE AND REEL BOX DIMENSIONS**

\*All dimensions are nominal

| Device          | Package Type | Package Drawing | Pins | SPQ  | Length (mm) | Width (mm) | Height (mm) |
|-----------------|--------------|-----------------|------|------|-------------|------------|-------------|
| SN74LV244ADBR   | SSOP         | DB              | 20   | 2000 | 367.0       | 367.0      | 38.0        |
| SN74LV244ADGVR  | TVSOP        | DGV             | 20   | 2000 | 367.0       | 367.0      | 35.0        |
| SN74LV244ADWR   | SOIC         | DW              | 20   | 2000 | 367.0       | 367.0      | 45.0        |
| SN74LV244ANSR   | SO           | NS              | 20   | 2000 | 367.0       | 367.0      | 45.0        |
| SN74LV244APWR   | TSSOP        | PW              | 20   | 2000 | 364.0       | 364.0      | 27.0        |
| SN74LV244APWRG3 | TSSOP        | PW              | 20   | 2000 | 364.0       | 364.0      | 27.0        |
| SN74LV244APWT   | TSSOP        | PW              | 20   | 250  | 367.0       | 367.0      | 38.0        |
| SN74LV244ARGYR  | VQFN         | RGY             | 20   | 3000 | 367.0       | 367.0      | 35.0        |

RGY (R-PVQFN-N20)

PLASTIC QUAD FLATPACK NO-LEAD



- NOTES:
- A. All linear dimensions are in millimeters. Dimensioning and tolerancing per ASME Y14.5M-1994.
  - B. This drawing is subject to change without notice.
  - C. QFN (Quad Flatpack No-Lead) package configuration.
  - D. The package thermal pad must be soldered to the board for thermal and mechanical performance.
  - E. See the additional figure in the Product Data Sheet for details regarding the exposed thermal pad features and dimensions.
  - F. Pin 1 identifiers are located on both top and bottom of the package and within the zone indicated. The Pin 1 identifiers are either a molded, marked, or metal feature.
  - G. Package complies to JEDEC MO-241 variation BA.

RGY (R-PVQFN-N20)

PLASTIC QUAD FLATPACK NO-LEAD

**THERMAL INFORMATION**

This package incorporates an exposed thermal pad that is designed to be attached directly to an external heatsink. The thermal pad must be soldered directly to the printed circuit board (PCB). After soldering, the PCB can be used as a heatsink. In addition, through the use of thermal vias, the thermal pad can be attached directly to the appropriate copper plane shown in the electrical schematic for the device, or alternatively, can be attached to a special heatsink structure designed into the PCB. This design optimizes the heat transfer from the integrated circuit (IC).

For information on the Quad Flatpack No-Lead (QFN) package and its advantages, refer to Application Report, QFN/SON PCB Attachment, Texas Instruments Literature No. SLUA271. This document is available at [www.ti.com](http://www.ti.com).

The exposed thermal pad dimensions for this package are shown in the following illustration.



Bottom View

Exposed Thermal Pad Dimensions

4206353-4/P 03/14

NOTE: All linear dimensions are in millimeters

RGY (R-PVQFN-N20)

PLASTIC QUAD FLATPACK NO-LEAD



4208122-4/P 03/14

- NOTES:
- A. All linear dimensions are in millimeters.
  - B. This drawing is subject to change without notice.
  - C. Publication IPC-7351 is recommended for alternate designs.
  - D. This package is designed to be soldered to a thermal pad on the board. Refer to Application Note, Quad Flat-Pack QFN/SON PCB Attachment, Texas Instruments Literature No. SLUA271, and also the Product Data Sheets for specific thermal information, via requirements, and recommended board layout. These documents are available at [www.ti.com](http://www.ti.com) <<http://www.ti.com>>.
  - E. Laser cutting apertures with trapezoidal walls and also rounding corners will offer better paste release. Customers should contact their board assembly site for stencil design recommendations. Refer to IPC 7525 for stencil design considerations.
  - F. Customers should contact their board fabrication site for minimum solder mask web tolerances between signal pads.

# MECHANICAL DATA

NS (R-PDSO-G\*\*)

PLASTIC SMALL-OUTLINE PACKAGE

14-PINS SHOWN



- NOTES:
- A. All linear dimensions are in millimeters.
  - B. This drawing is subject to change without notice.
  - C. Body dimensions do not include mold flash or protrusion, not to exceed 0,15.

DGV (R-PDSO-G\*\*)

PLASTIC SMALL-OUTLINE

24 PINS SHOWN



- NOTES: A. All linear dimensions are in millimeters.  
 B. This drawing is subject to change without notice.  
 C. Body dimensions do not include mold flash or protrusion, not to exceed 0,15 per side.  
 D. Falls within JEDEC: 24/48 Pins – MO-153  
 14/16/20/56 Pins – MO-194

PW (R-PDSO-G20)

PLASTIC SMALL OUTLINE



4040064-5/G 02/11

- NOTES:
- A. All linear dimensions are in millimeters. Dimensioning and tolerancing per ASME Y14.5M-1994.
  - B. This drawing is subject to change without notice.
  - C. Body length does not include mold flash, protrusions, or gate burrs. Mold flash, protrusions, or gate burrs shall not exceed 0,15 each side.
  - D. Body width does not include interlead flash. Interlead flash shall not exceed 0,25 each side.
  - E. Falls within JEDEC MO-153

PW (R-PDSO-G20)

PLASTIC SMALL OUTLINE



- NOTES:
- A. All linear dimensions are in millimeters.
  - B. This drawing is subject to change without notice.
  - C. Publication IPC-7351 is recommended for alternate design.
  - D. Laser cutting apertures with trapezoidal walls and also rounding corners will offer better paste release. Customers should contact their board assembly site for stencil design recommendations. Refer to IPC-7525 for other stencil recommendations.
  - E. Customers should contact their board fabrication site for solder mask tolerances between and around signal pads.

# DB0020A



# PACKAGE OUTLINE

## TSSOP - 2 mm max height

SMALL OUTLINE PACKAGE

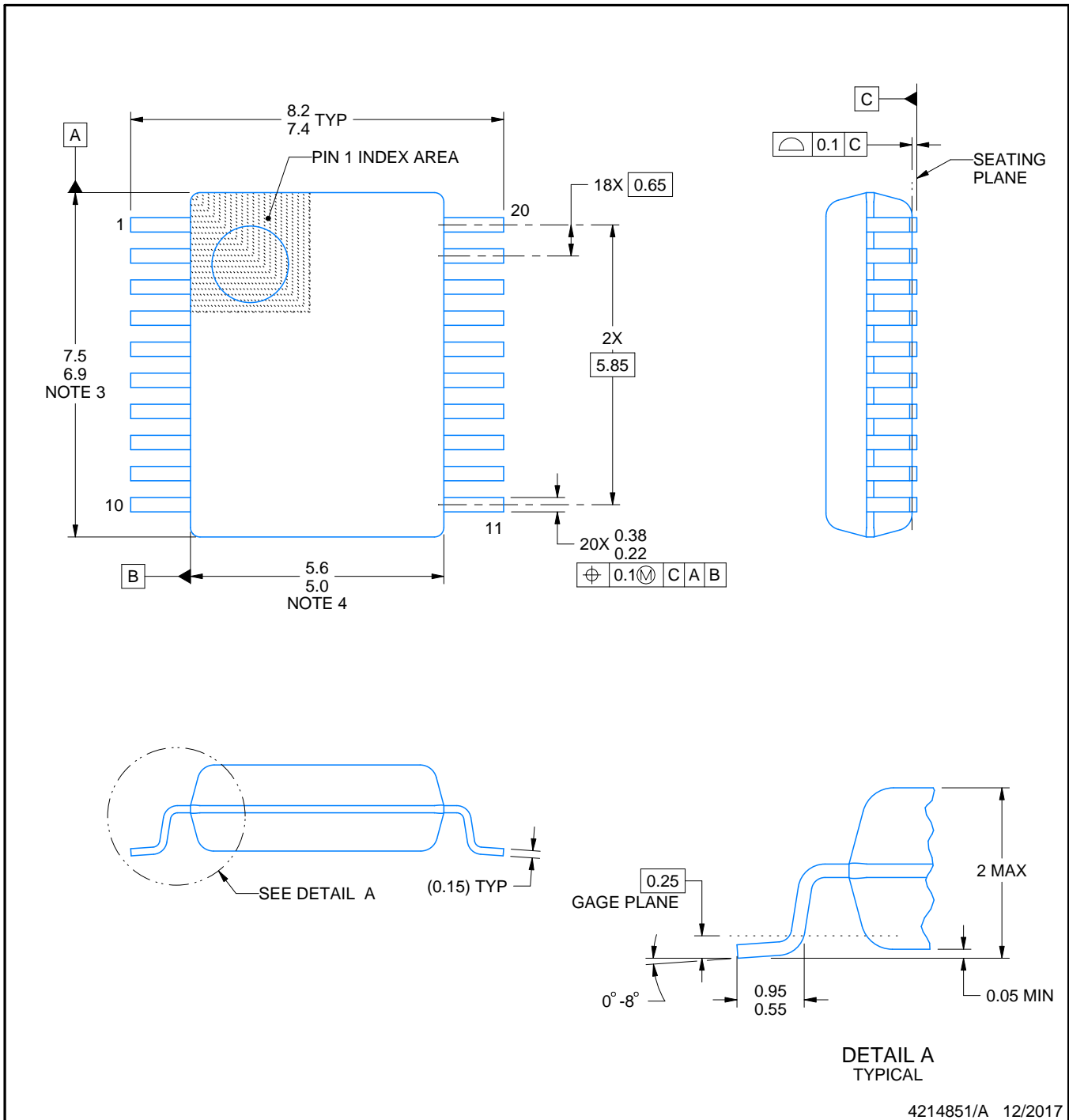

4214851/A 12/2017

### NOTES:

1. All linear dimensions are in millimeters. Any dimensions in parenthesis are for reference only. Dimensioning and tolerancing per ASME Y14.5M.
2. This drawing is subject to change without notice.
3. This dimension does not include mold flash, protrusions, or gate burrs. Mold flash, protrusions, or gate burrs shall not exceed 0.15 mm per side.
4. This dimension does not include interlead flash. Interlead flash shall not exceed 0.25 mm per side.
5. Reference JEDEC registration MO-150.

# EXAMPLE BOARD LAYOUT

DB0020A

TSSOP - 2 mm max height

SMALL OUTLINE PACKAGE



LAND PATTERN EXAMPLE  
EXPOSED METAL SHOWN  
SCALE: 10X



SOLDER MASK DETAILS

4214851/A 12/2017

NOTES: (continued)

- 6. Publication IPC-7351 may have alternate designs.
- 7. Solder mask tolerances between and around signal pads can vary based on board fabrication site.

# EXAMPLE STENCIL DESIGN

DB0020A

TSSOP - 2 mm max height

SMALL OUTLINE PACKAGE



SOLDER PASTE EXAMPLE  
BASED ON 0.125 mm THICK STENCIL  
SCALE: 10X

4214851/A 12/2017

NOTES: (continued)

8. Laser cutting apertures with trapezoidal walls and rounded corners may offer better paste release. IPC-7525 may have alternate design recommendations.
9. Board assembly site may have different recommendations for stencil design.

# DW0020A



# PACKAGE OUTLINE

## SOIC - 2.65 mm max height

SOIC



4220724/A 05/2016

**NOTES:**

1. All linear dimensions are in millimeters. Dimensions in parenthesis are for reference only. Dimensioning and tolerancing per ASME Y14.5M.
2. This drawing is subject to change without notice.
3. This dimension does not include mold flash, protrusions, or gate burrs. Mold flash, protrusions, or gate burrs shall not exceed 0.15 mm per side.
4. This dimension does not include interlead flash. Interlead flash shall not exceed 0.43 mm per side.
5. Reference JEDEC registration MS-013.

# EXAMPLE BOARD LAYOUT

DW0020A

SOIC - 2.65 mm max height

SOIC



LAND PATTERN EXAMPLE  
SCALE:6X



SOLDER MASK DETAILS

4220724/A 05/2016

NOTES: (continued)

- 6. Publication IPC-7351 may have alternate designs.
- 7. Solder mask tolerances between and around signal pads can vary based on board fabrication site.

# EXAMPLE STENCIL DESIGN

DW0020A

SOIC - 2.65 mm max height

SOIC

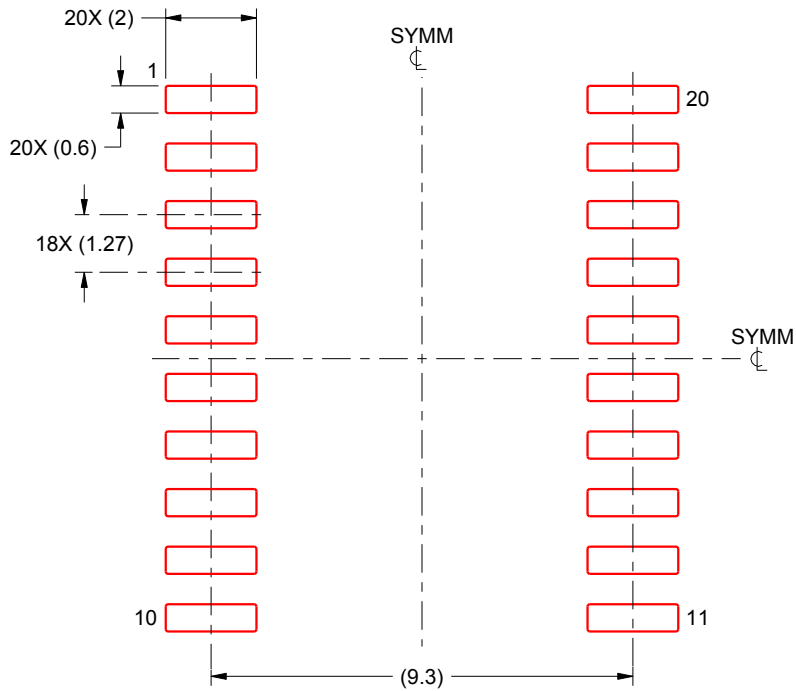

SOLDER PASTE EXAMPLE  
BASED ON 0.125 mm THICK STENCIL  
SCALE:6X

4220724/A 05/2016

NOTES: (continued)

8. Laser cutting apertures with trapezoidal walls and rounded corners may offer better paste release. IPC-7525 may have alternate design recommendations.
9. Board assembly site may have different recommendations for stencil design.

## IMPORTANT NOTICE AND DISCLAIMER

TI PROVIDES TECHNICAL AND RELIABILITY DATA (INCLUDING DATASHEETS), DESIGN RESOURCES (INCLUDING REFERENCE DESIGNS), APPLICATION OR OTHER DESIGN ADVICE, WEB TOOLS, SAFETY INFORMATION, AND OTHER RESOURCES "AS IS" AND WITH ALL FAULTS, AND DISCLAIMS ALL WARRANTIES, EXPRESS AND IMPLIED, INCLUDING WITHOUT LIMITATION ANY IMPLIED WARRANTIES OF MERCHANTABILITY, FITNESS FOR A PARTICULAR PURPOSE OR NON-INFRINGEMENT OF THIRD PARTY INTELLECTUAL PROPERTY RIGHTS.

These resources are intended for skilled developers designing with TI products. You are solely responsible for (1) selecting the appropriate TI products for your application, (2) designing, validating and testing your application, and (3) ensuring your application meets applicable standards, and any other safety, security, or other requirements. These resources are subject to change without notice. TI grants you permission to use these resources only for development of an application that uses the TI products described in the resource. Other reproduction and display of these resources is prohibited. No license is granted to any other TI intellectual property right or to any third party intellectual property right. TI disclaims responsibility for, and you will fully indemnify TI and its representatives against, any claims, damages, costs, losses, and liabilities arising out of your use of these resources.

TI's products are provided subject to TI's Terms of Sale ([www.ti.com/legal/termsofsale.html](http://www.ti.com/legal/termsofsale.html)) or other applicable terms available either on [ti.com](http://ti.com) or provided in conjunction with such TI products. TI's provision of these resources does not expand or otherwise alter TI's applicable warranties or warranty disclaimers for TI products.

Mailing Address: Texas Instruments, Post Office Box 655303, Dallas, Texas 75265  
Copyright © 2019, Texas Instruments Incorporated

## Looking for pricing, stock, or lifecycle information?

Click below to explore more details on WIN SOURCE:

 [View SN74LV244ADW](#) on WIN SOURCE

 [Texas Instruments](#) Information

## Optimize Your Supply Chain with WIN SOURCE Solutions

-  Global Sourcing Solution
-  Obsolete Management
-  Cost Control Management
-  Shortage Management
-  Alternative Solution
-  Excess Inventory Management