



# THE DATASHEET OF STM86312



---

**1/4 to 1/11-duty VFD controller/driver**

---

**General features**

- Many display modes (11 segments & 11 digits to 16 segments & 4 digits)
- Key scanning (6 x 4 matrix)
- Dimming circuit (eight steps)
- High-voltage output ( $V_{DD} - 35V$  max)
- LED ports (4 chs, 20mA max)
- General purpose input port (4 bits)
- No external resistor necessary for driver output (P-channel open drain + pull down resistor output)
- Serial interface (CLK, STB,  $D_{IN}$ ,  $D_{OUT}$ )

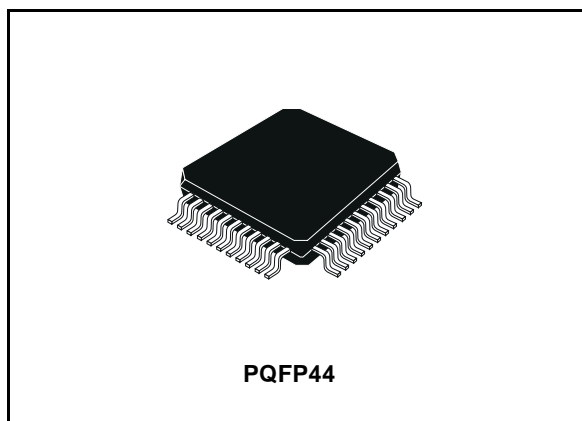
**Description**

The STM86312 is a VFD (Vacuum Fluorescent Display) controller/driver that is driven on a 1/4 to 1/11-duty factor. It consists of 11-segments output lines, 6 grid output lines, 5 segments/grid output drive lines, a display memory, a control circuit, and a key scan circuit. Serial data are input to the STM86312 through a three-line serial interface. This VFD controller/driver is ideal as a peripheral device for a single-chip microcomputer.

**Order codes**

Part number	Temperature range	Package	Tube
STM86312	-40 to 85 °C	PQFP44	Tray

# Contents

<b>1</b>	<b>Block diagram</b> .....	<b>3</b>
<b>2</b>	<b>Pin settings</b> .....	<b>4</b>
2.1	Pin connection .....	4
2.2	Pin description .....	5
<b>3</b>	<b>Maximum rating</b> .....	<b>6</b>
3.1	Thermal data .....	6
3.2	Recommended operating conditions .....	6
<b>4</b>	<b>Electrical characteristics</b> .....	<b>8</b>
<b>5</b>	<b>Display RAM address and display mode</b> .....	<b>10</b>
<b>6</b>	<b>LED port</b> .....	<b>12</b>
<b>7</b>	<b>SW data</b> .....	<b>13</b>
<b>8</b>	<b>Commands</b> .....	<b>14</b>
8.1	Display mode setting command .....	14
8.2	Data setting command .....	15
8.3	Address setting command .....	15
8.4	Display control command .....	16
<b>9</b>	<b>Serial communication format</b> .....	<b>17</b>
<b>10</b>	<b>Application</b> .....	<b>19</b>
<b>11</b>	<b>Mechanical data</b> .....	<b>21</b>
<b>12</b>	<b>Revision history</b> .....	<b>23</b>

# 1 Block diagram

Figure 1. Block diagram

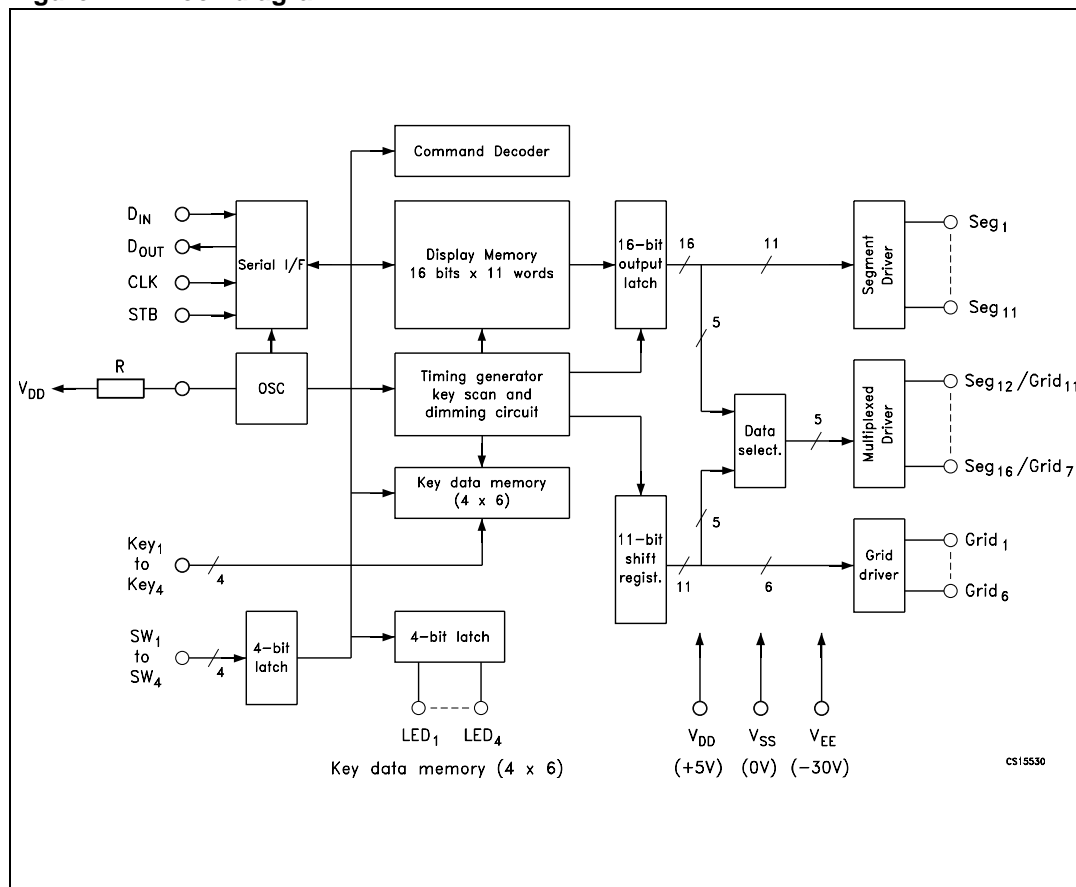

## 2 Pin settings

### 2.1 Pin connection

Figure 2. Pin connection

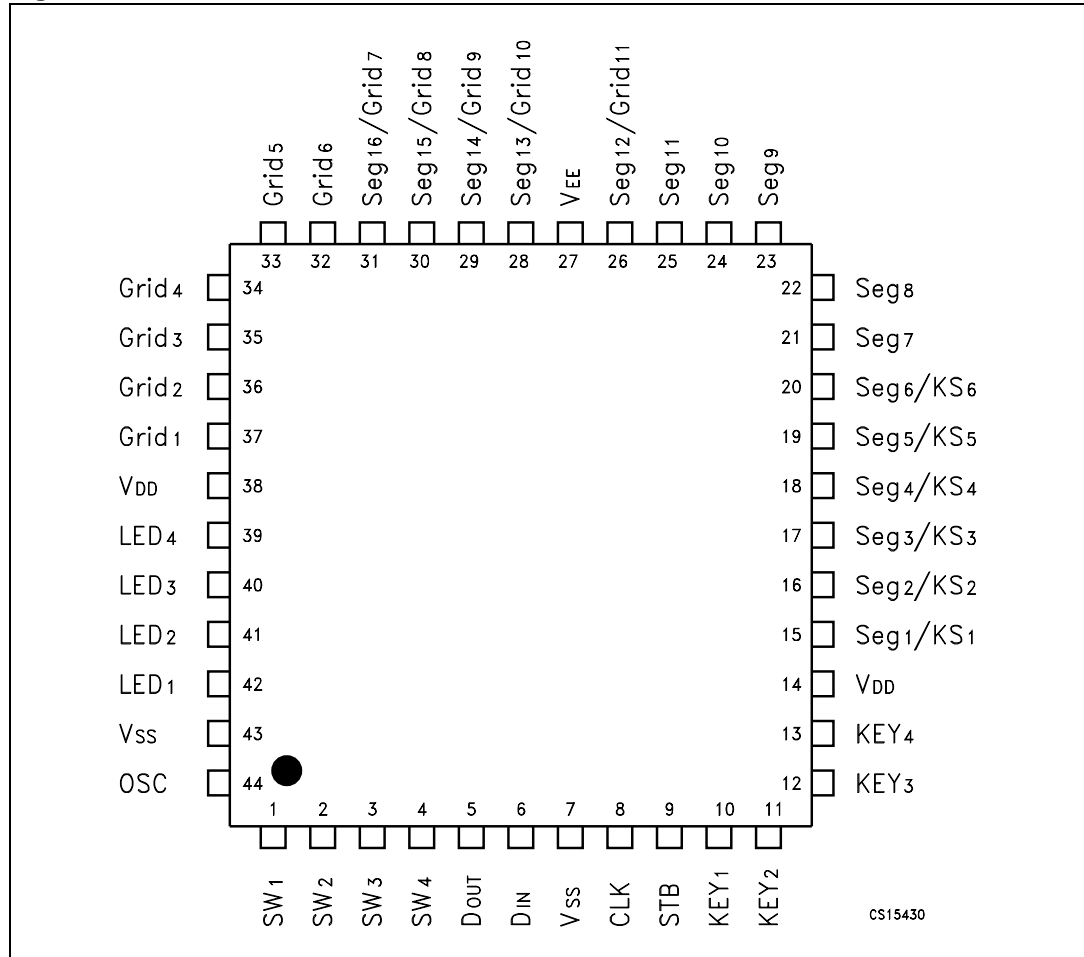

## 2.2 Pin description

Table 1. Pin description

Pin N°	Symbol	Name and function
1, 2, 3, 4	SW1, SW2, SW3, SW4	General-purpose switch inputs.
5	D <sub>OUT</sub>	Output serial data at falling edge of the shift clock, starting from lower bit. This is N-ch open-drain output pin.
6	D <sub>IN</sub>	Input serial data at rising edge of the shift clock, starting from lower bit.
8	CLK	Reads serial data at rising edge, and outputs data at falling edge.
9	STB	Initializes serial interface at rising or falling edge to make STM86312 waiting for reception of command. Data input after STB has fallen are processed as a command. While command data are processed, current processing is stopped, and the serial interface is initialized. While STB is high, CLK is ignored.
10, 11, 12, 13	KEY1, KEY2, KEY3, KEY4	Input data to these pins are latched at end of the display cycle.
14, 38	V <sub>DD</sub>	5V ± 10%.
15, 16, 17, 18, 19, 20	SEG1/KS1 to SEG6/KS6	Segment output pins (Dual function as key source).
21, 22, 23, 24, 25	SEG7 to SEG11	Segment output pins.
26, 28, 29, 30, 31	SEG12/GRID11 to SEG16/GRID7	These pins are selectable for segment or grid driving.
32, 33, 34, 35, 36, 37	GRID1 to GRID6	Grid output pins.
39, 40, 41, 42	LED1 to LED4	CMOS outputs. +20 mA max.
7, 43	V <sub>SS</sub>	Connect this pin to system GND.
27	V <sub>EE</sub>	Pull-down level. V <sub>DD</sub> - 35V max.
44	OSC	Connect to an external resistor.

### 3 Maximum rating

Stressing the device above the rating listed in the “Absolute Maximum Ratings” table may cause permanent damage to the device. These are stress ratings only and operation of the device at these or any other conditions above those indicated in the Operating sections of this specification is not implied. Exposure to Absolute Maximum Rating conditions for extended periods may affect device reliability. Refer also to the STMicroelectronics SURE Program and other relevant quality documents.

**Table 2. Absolute maximum ratings**

Symbol	Parameter	Value	Unit
V <sub>DD</sub>	Logic Supply Voltage	-0.5 to 7	V
V <sub>EE</sub>	Driver Supply Voltage	V <sub>DD</sub> +0.5 to V <sub>DD</sub> -40	V
V <sub>I</sub>	Logic Input Voltage	-0.5 to V <sub>DD</sub> +0.5	V
V <sub>O2</sub>	VFD Driver Output Voltage	V <sub>EE</sub> -0.5 to V <sub>DD</sub> +0.5	V
I <sub>O1</sub>	LED Driver Output Current	25	mA
I <sub>O2</sub>	VFD Driver Output Current	-40 (Grid)	mA
		-15 (Segment)	
T <sub>A</sub>	Operating Ambient Temperature	-40 to 85	°C

#### 3.1 Thermal data

**Table 3. Thermal data**

Symbol	Parameter	Value	Unit
R <sub>thJC</sub>	Thermal Resistance Junction-case	56	°C/W

#### 3.2 Recommended operating conditions

**Table 4. Recommended operating conditions**

Symbol	Parameter	Min	Typ	Max	Unit
V <sub>DD</sub>	Logic Supply Voltage	4.5	5	5.5	V
V <sub>IH</sub>	High Level Input Voltage	0.7xV <sub>DD</sub>		V <sub>DD</sub>	V
V <sub>IL</sub>	Low Level Input Voltage	0		0.3xV <sub>DD</sub>	V
V <sub>EE</sub>	Driver Supply Voltage	0		V <sub>DD</sub> -35	V

Maximum power consumption  $P_{MAX} = \text{VFD driver dissipation} + R_L \text{ dissipation} + \text{LED driver dissipation} + \text{dynamic power consumption}$ .

Where segment current = 3 mA, grid current = 15 mA, and LED current = 20 mA,

VFD driver dissipation = number of segments x 6 + number of grids/(number of grids + 1) x 30 (mW)

$R_L$  dissipation =  $(V_{DD} - V_{EE})^2/50 \times (\text{segment} + 1)$  (mW)

LED driver dissipation = number of LEDs x 20 (mW)

Dynamic power consumption =  $V_{DD} \times 5$  (mW)

#### Example

Where  $V_{EE} = -25$  V,  $V_{DD} = 5$  V, and in 16-segment and 6-digit modes,

VFD driver dissipation =  $16 \times 6 + 6/7 \times 30 = 122$

$R_L$  dissipation =  $30^2/50 \times 17 = 306$

LED driver dissipation =  $4 \times 20 = 80$

Dynamic power consumption =  $5 \times 5 = 25$

Total 553 mW.

## 4 Electrical characteristics

**Table 5. Electrical characteristics** ( $V_{DD} = 4.5$  to  $5.5V$ ,  $V_{SS} = 0V$ ,  $V_{EE} = V_{DD} - 35V$ ,  $T_A = -20$  to  $70^\circ C$ , unless otherwise noted. Typical values are at  $T_A = 25^\circ C$ )

Symbol	Parameter	Test Conditions	Value			Unit
			Min.	Typ.	Max.	
$V_{OH1}$	High Level Output Voltage	LED1-LED4, $I_{OH1} = -1mA$	$0.9V_{DD}$			V
$V_{OL1}$	Low Level Output Voltage	LED1-LED4, $I_{OL1} = 20mA$			1	V
$V_{OL2}$	Low Level Output Voltage	$D_{OUT}$ , $I_{OL2} = 4mA$			0.4	V
$I_{OH21}$	High Level Output Current	$V_O = V_{DD} - 2V$ , Seg1 to Seg11	-3			mA
$I_{OH22}$	High Level Output Current	$V_O = V_{DD} - 2V$ , Grid1 to Grid6, Seg12/Grid11 to Seg16/Grid7	-15			mA
$I_{OLEAK}$	Driver Leakage Current	$V_O = V_{DD} - 35V$ , driver off			-10	$\mu A$
$R_L$	Output Pull-Down Resistor	Driver Output	50	100	150	$k\Omega$
$I_I$	Input Current	$V_I = V_{DD}$ or $V_{SS}$			$\pm 1$	$\mu A$
$V_{IH}$	High Level Input Voltage		$0.7V_{DD}$			V
$V_{IL}$	Low Level Input Voltage				$0.3V_{DD}$	V
$V_{HYS}$	Hysteresis Voltage	CLK, $D_{IN}$ , STB		0.35		V
$I_{DDdyn}$	Dynamic Current Consumption	Under no load, display off			5	mA

**Table 6. Switching characteristics** ( $V_{DD} = 4.5$  to  $5.5V$ ,  $V_{SS} = 0V$ ,  $V_{EE} = V_{DD} - 35V$ ,  $T_A = -20$  to  $70^\circ C$ , unless otherwise noted. Typical values are at  $T_A = 25^\circ C$ )

Symbol	Parameter	Test Conditions	Value			Unit
			Min.	Typ.	Max.	
$t_{PLZ}$	Propagation Delay	CLK $\rightarrow$ $D_{OUT}$ $R_L = 10 k\Omega$ , $C_L = 15 pF$			300	ns
$t_{PZL}$					100	
$t_{TZH1}$	Rise Time	$C_L = 300 pF$ Seg1 to Seg11			2	$\mu s$
$t_{TZH2}$			Grid1 to Grid6, Seg12/Grid11 to Seg16/Grid7			
$t_{THZ}$	Fall Time	$C_L = 300 pF$ , Segn, Gridn			120	$\mu s$
$f_{MAX}$	Maximum Clock Frequency	Duty = 50%	1			MHz
$C_I$	Input Capacitance				15	pF

**Table 7. Timing Characteristics** ( $V_{DD} = 4.5$  to  $5.5V$ ,  $T_A = -20$  to  $70^\circ C$ , unless otherwise noted. Typical values are at  $T_A = 25^\circ C$ )

Symbol	Parameter	Test Conditions	Value			Unit
			Min.	Typ.	Max.	
$PW_{CLK}$	Clock Pulse Width		400			ns
$PW_{STB}$	Strobe Pulse Width		1			$\mu s$
$t_{SETUP}$	Data Setup Time		100			ns
$t_{HOLD}$	Data Hold Time		100			ns
$t_{CLK-STB}$	Clock-Strobe Time	CLK $\uparrow$ $\rightarrow$ STB $\uparrow$	1			$\mu s$
$t_{WAIT}$	Wait Time (Note 1)	CLK $\uparrow$ $\rightarrow$ CLK $\downarrow$	1			$\mu s$

Note: Refer to page Serial Communication Format.

## 5 Display RAM address and display mode

The display RAM stores the data transmitted from an external device to the STM86312 through the serial interface; addresses are as follows, in 8-bits unit:

RAM stores addresses

Seg1	Seg4	Seg8	Seg12	Seg16	
00 H <sub>L</sub>		00 H <sub>U</sub>	01 H <sub>L</sub>	01 H <sub>U</sub>	DIG1
02 H <sub>L</sub>		02 H <sub>U</sub>	03 H <sub>L</sub>	03 H <sub>U</sub>	DIG2
04 H <sub>L</sub>		04 H <sub>U</sub>	05 H <sub>L</sub>	05 H <sub>U</sub>	DIG3
06 H <sub>L</sub>		06 H <sub>U</sub>	07 H <sub>L</sub>	07 H <sub>U</sub>	DIG4
08 H <sub>L</sub>		08 H <sub>U</sub>	09 H <sub>L</sub>	09 H <sub>U</sub>	DIG5
0A H <sub>L</sub>		0A H <sub>U</sub>	0B H <sub>L</sub>	0B H <sub>U</sub>	DIG6
0C H <sub>L</sub>		0C H <sub>U</sub>	0D H <sub>L</sub>	0D H <sub>U</sub>	DIG7
0E H <sub>L</sub>		0E H <sub>U</sub>	0F H <sub>L</sub>	0F H <sub>U</sub>	DIG8
10 H <sub>L</sub>		10 H <sub>U</sub>	11 H <sub>L</sub>	11 H <sub>U</sub>	DIG9
12 H <sub>L</sub>		12 H <sub>U</sub>	13 H <sub>L</sub>	13 H <sub>U</sub>	DIG10
14 H <sub>L</sub>		14 H <sub>U</sub>	15 H <sub>L</sub>	15 H <sub>U</sub>	DIG11



Note: "0" in memory means V<sub>EE</sub> on output; "1" in memory means V<sub>DD</sub> on output.

The key matrix is of 6 x 4 configuration, as shown below

Figure 3. Key matrix and key-input data storage RAM

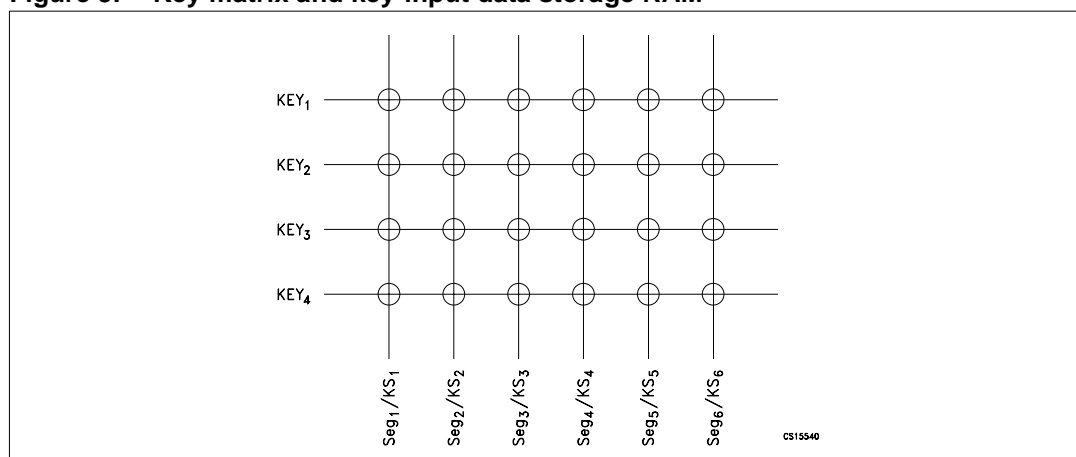

The data of each key are stored as illustrated below, and are read by the appropriate read command, starting from the least significant bit

KEY1	KEY4	KEY1	KEY4	
Seg1/KS1			Seg2/KS2	∅
Seg3/KS3			Seg4/KS4	
Seg5/KS5			Seg6/KS6	
b0	b3	b4	b7	

## 6 LED port

Data are written to the LED port by a write command, starting from the least significant bit of the port. When a bit of this port is 0, the corresponding LED lights; when the bit is 1, the LED goes off. The data of bits 5 through 8 are ignored.

**Figure 4. LED port**

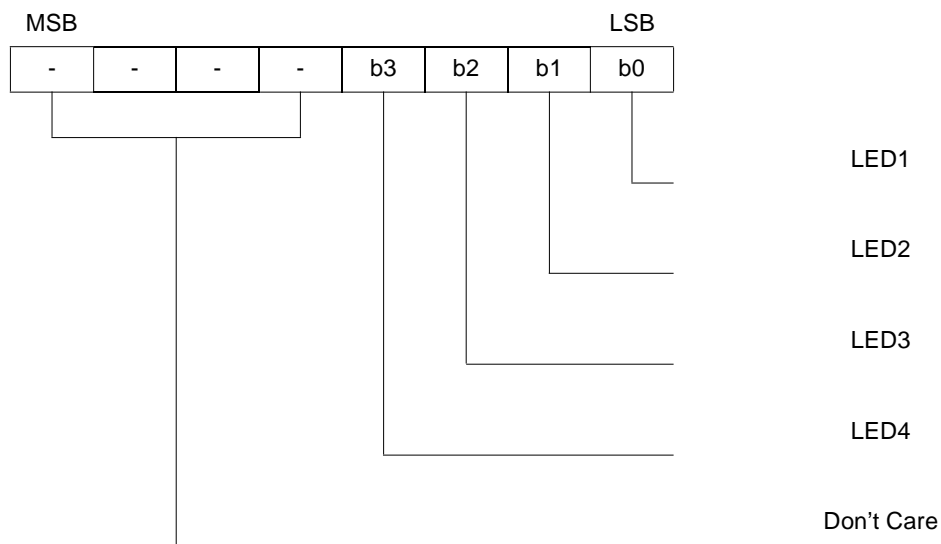

On power application, all the LEDs remain dark.

## 7 SW data

The SW data are read by the appropriate read command, starting from the least significant bit. Bits 5 through 8 of the SW data are 0.

**Figure 5. SW data**

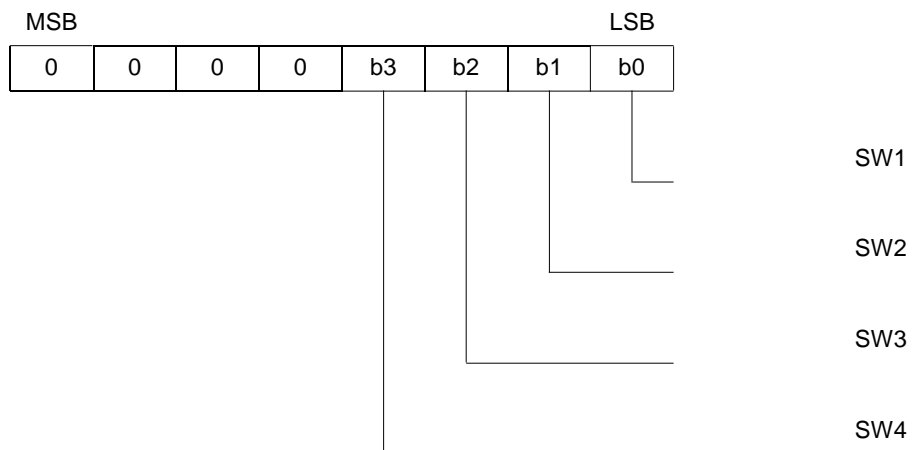

# 8 Commands

A command sets the display mode and status of the VFD driver.

The first 1 byte input to the STM86312 through the D<sub>IN</sub> pin after the STB pin has fallen is regarded as a command. If STB is set high while commands/data are transmitted, serial communication is initialized, and the commands/data being transmitted are invalid (however, the commands/data already transmitted remain valid).

## 8.1 Display mode setting command

This command initializes the STM86312 and selects the number of segments and number of grids (1/4 to 1/11 duty, 11 segments to 16 segments).

When this command is executed, display is forcibly turned off, and key scanning is also stopped. To resume display, the display ON command must be executed. If the same mode is selected, however, nothing is performed.

**Figure 6. Display mode settings**

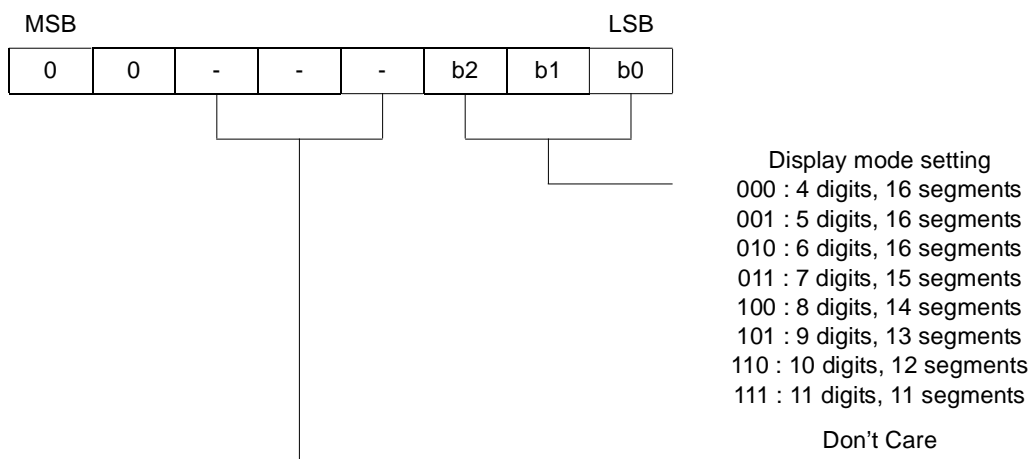

On power application, the 11-digit 11-segment mode is selected.

## 8.2 Data setting command

This command sets data write and data read modes.

**Figure 7. Data setting command**

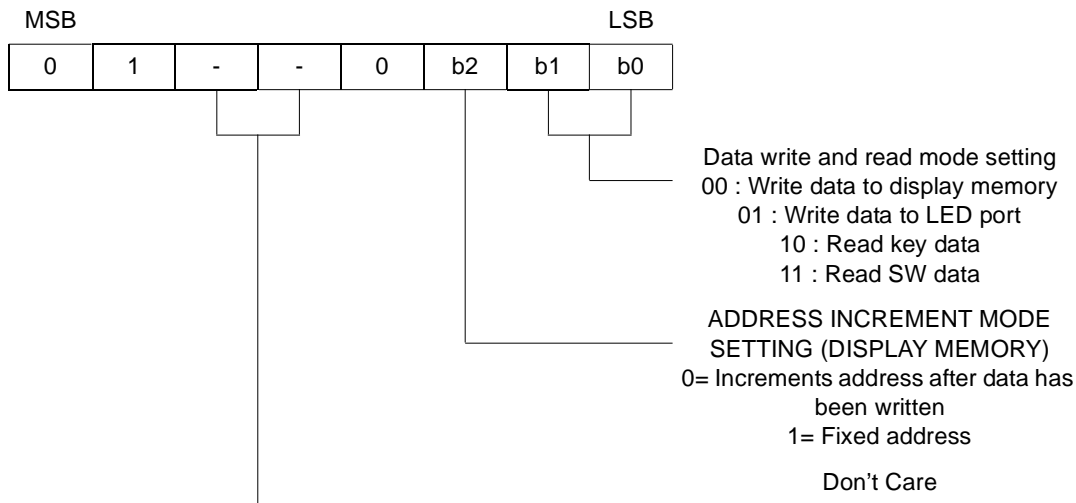

On power application, the normal operation mode and address increment mode are set. Do not use STM86312 in test mode.

## 8.3 Address setting command

This command sets an address of the display memory

**Figure 8. Address setting command**

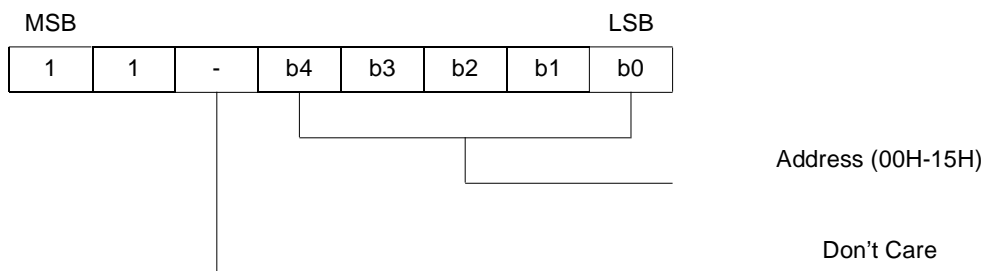

If address 16H or higher is set, the data are ignored, until a correct address is set. On power application, the address is set to 00H.

### 8.4 Display control command

Figure 9. Display control command

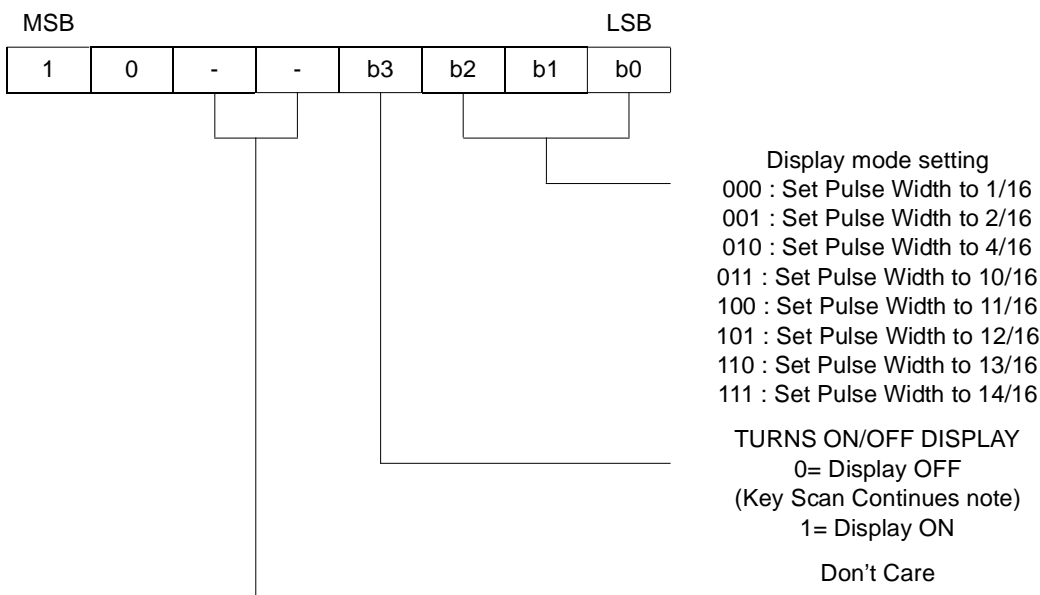

On power application, the 1/16-pulse width is set and the display is turned off.

Note: On power application, key scanning is stopped.

Figure 10. Key scanning and display timing

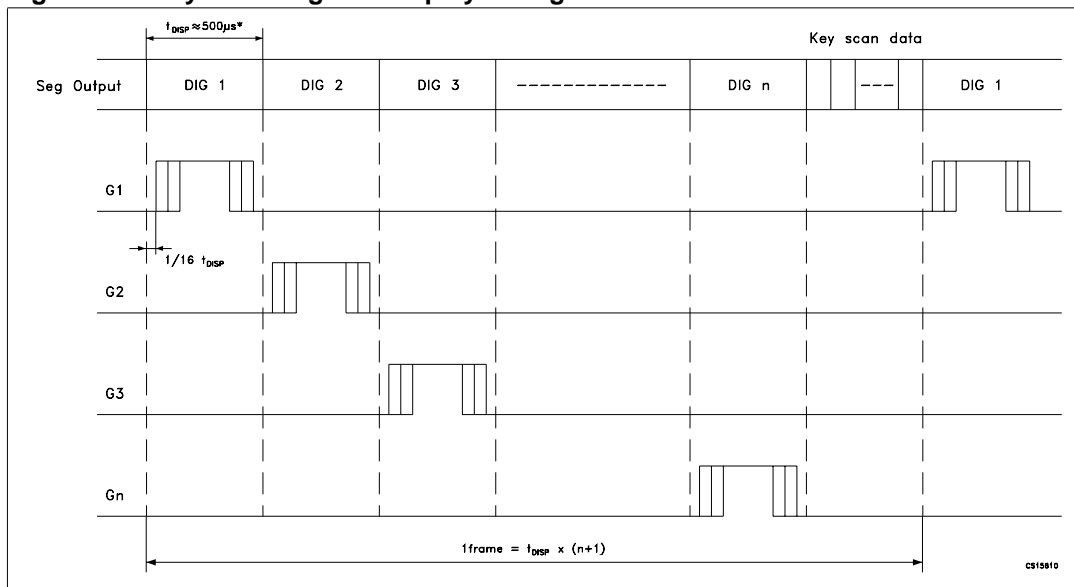

Note: \* The value can be modified by trimming  $R_{OSC}$ .

One cycle of key scanning consists of one frame, and data of 6 x 4 matrices are stored in RAM.

# 9 Serial communication format

Figure 11. Reception (command/data write)

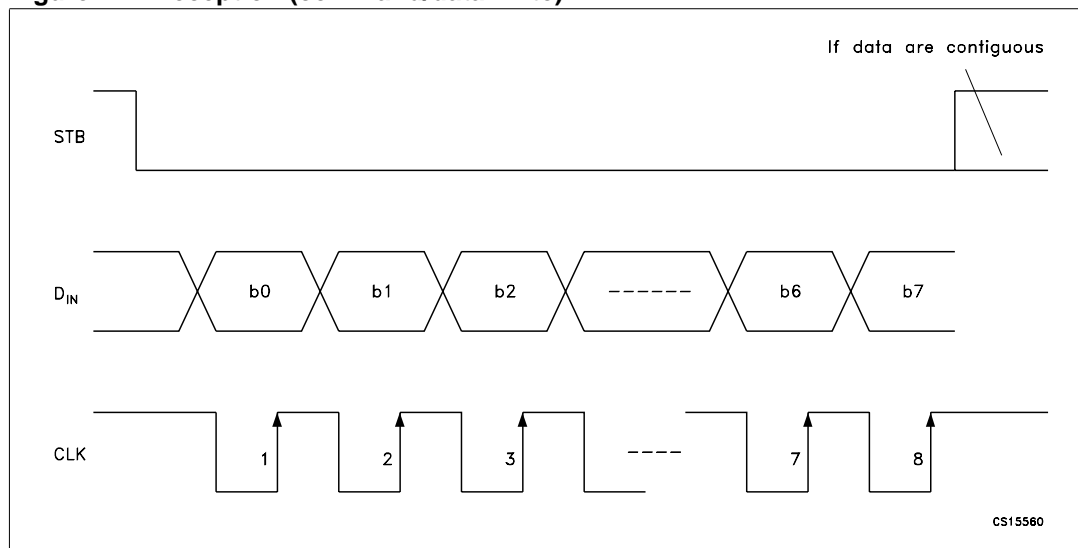
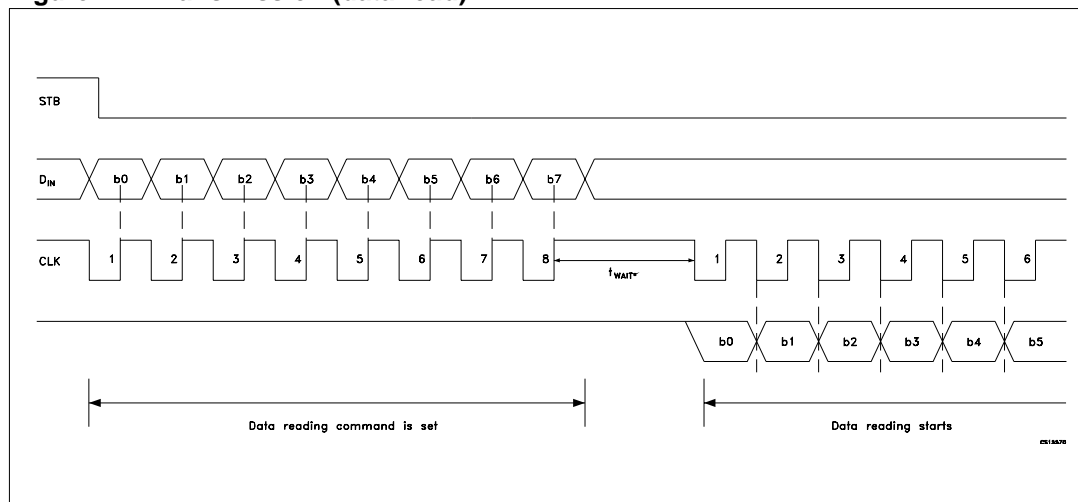

Figure 12. Transmission (data read)



Because the D<sub>OUT</sub> pin is an N-ch open-drain output pin, be sure to connect an external pull-up resistor to this pin (1 kΩ to 10 kΩ).

Note: \*: When data are read, a wait time  $t_{WAIT}$  of 1μs is necessary within the rising edge of the eighth clock that has set the command and the falling one of the first clock that has read the data.

Figure 13. Switching characteristics waveform

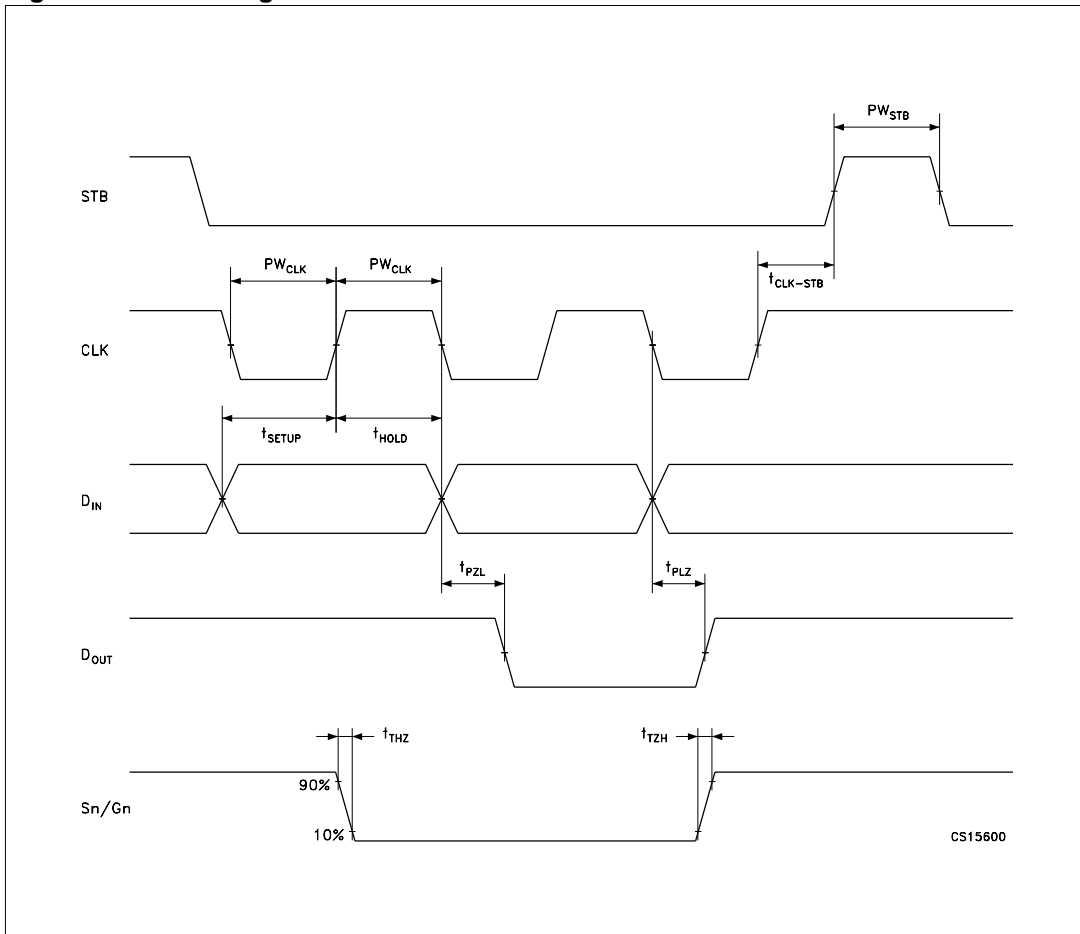

# 10 Application

**Figure 14. Updating display memory by incrementing address**

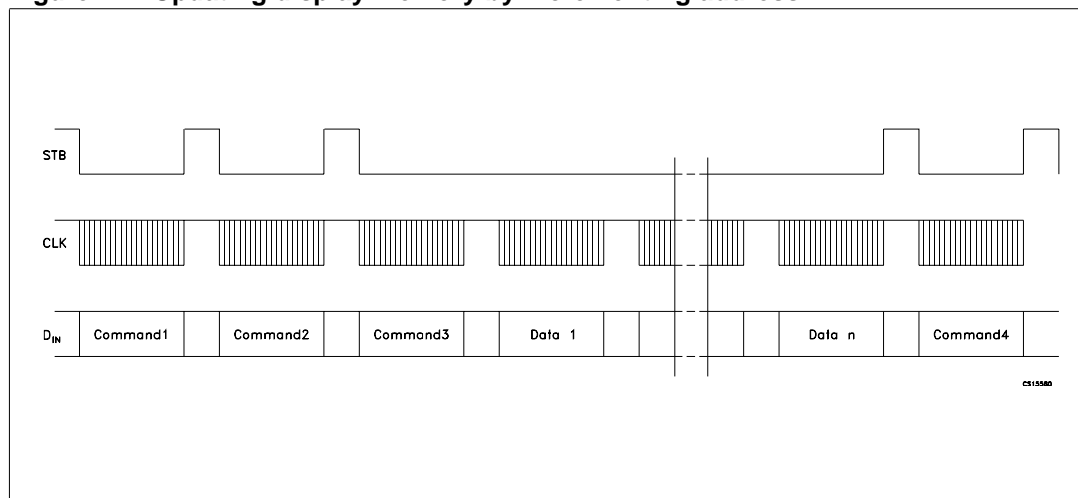

- Command 1: sets display mode
- Command 2: sets data
- Command 3: sets address
- Data 1 to n: transfers display data (22 bytes max.)
- Command 4: controls display

**Figure 15. Updating specific address**

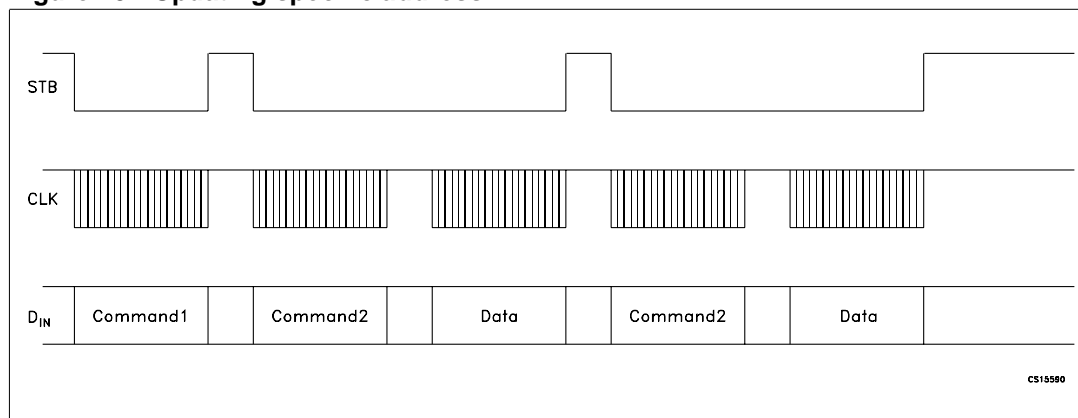

- Command 1: sets data
- Command 2: sets address
- Data: display data

Figure 16. Application circuit

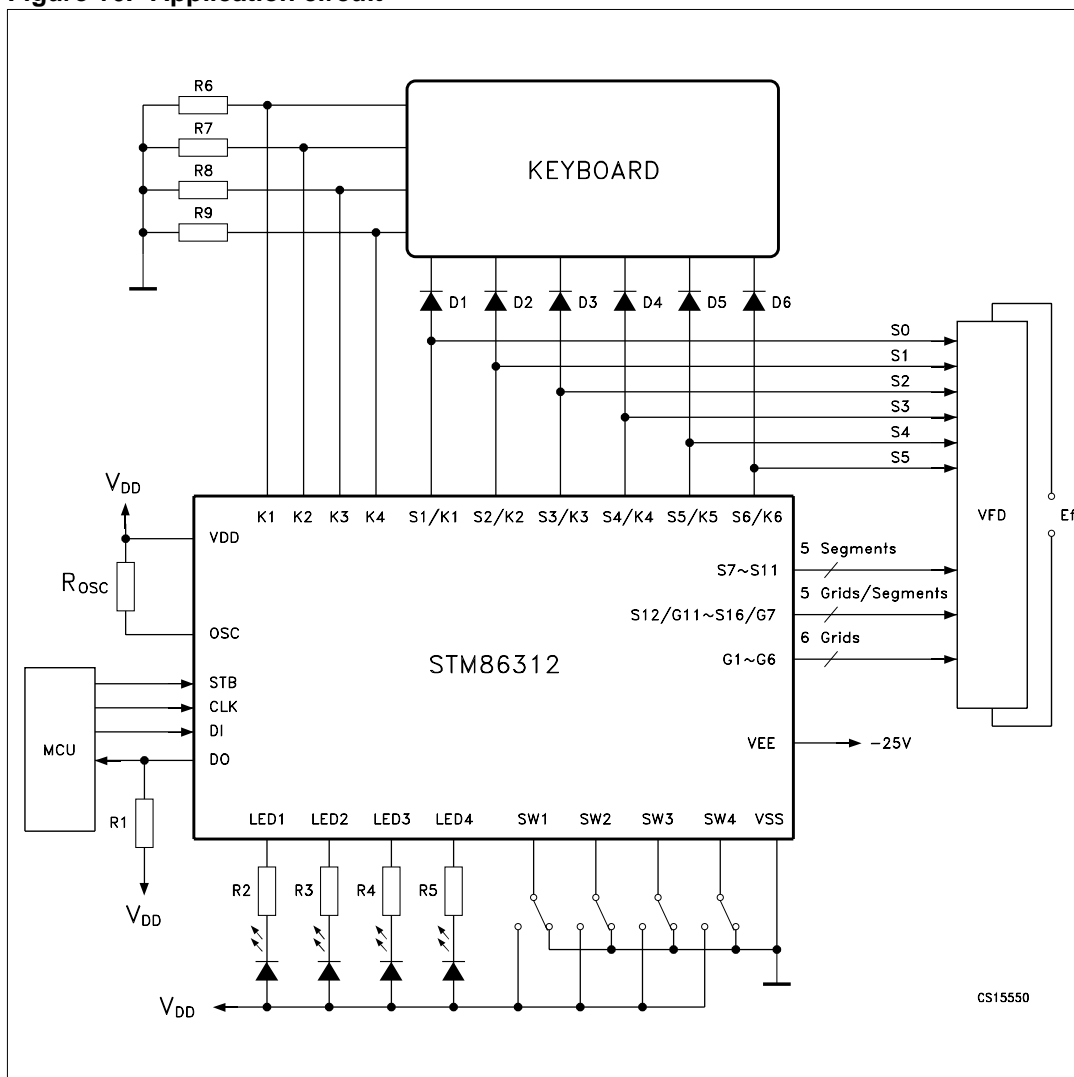

- Note:
- 1  $R_{OSC} = 47k\Omega$  for oscillator resistor
  - 2  $R1 = 1\sim 10 k\Omega$  for external pull-high resistor
  - 3  $R2\sim R5 = 750\Omega\sim 1.2 k\Omega$
  - 4  $R6\sim R9 = 10k\Omega$  for external pull-low resistor
  - 5  $D1\sim D6 = 1N4001$
  - 6  $Ef =$  Filament voltage for VFD.

## 11 Mechanical data

In order to meet environmental requirements, ST offers these devices in ECOPACK® packages. These packages have a Lead-free second level interconnect . The category of second level interconnect is marked on the package and on the inner box label, in compliance with JEDEC Standard JESD97. The maximum ratings related to soldering conditions are also marked on the inner box label. ECOPACK is an ST trademark. ECOPACK specifications are available at: [www.st.com](http://www.st.com)

**PQFP44 MECHANICAL DATA**

DIM.	mm.			inch		
	MIN.	TYP	MAX.	MIN.	TYP.	MAX.
A			2.45			0.096
A1			0.25			0.010
A2	1.80	2.00	2.20	0.071	0.079	0.087
b	0.29		0.45	0.011		0.018
c	0.11		0.23	0.004		0.009
D		13.2			0.520	
D1		10.00			0.394	
D3		8.00			0.315	
E		13.2			0.520	
E1		10.00			0.394	
E3		8.00			0.315	
e		0.80			0.031	
L	0.73	0.88	1.03	0.029	0.035	0.041
L1		1.6			0.063	
K	0°	3.5°	7°	0°	3.5°	7°

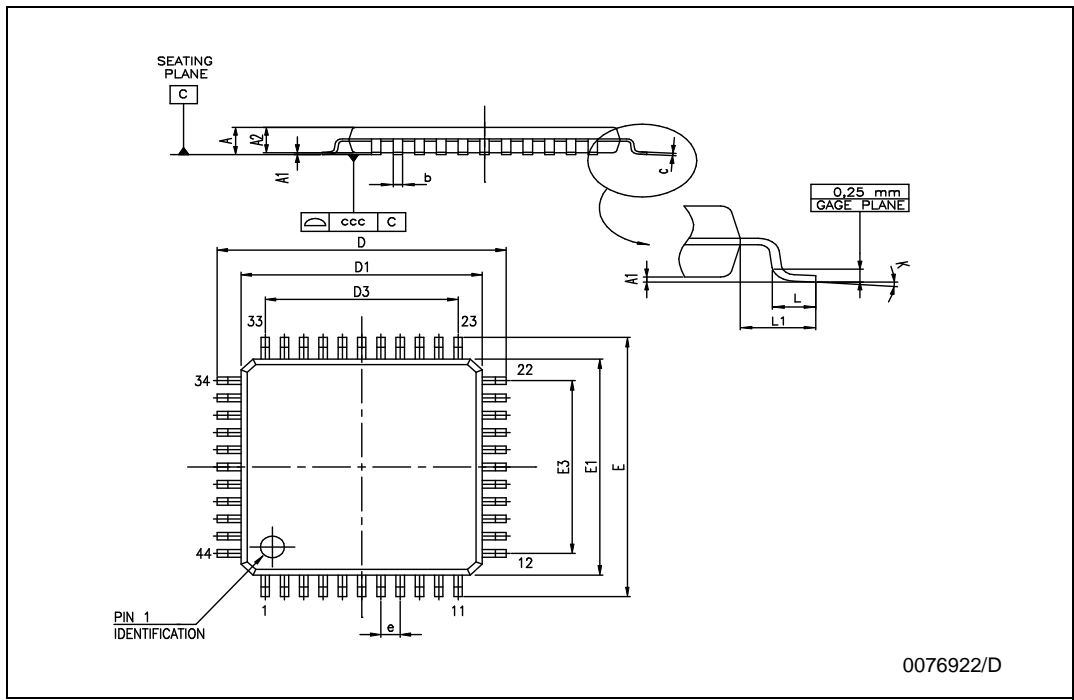

## 12 Revision history

**Table 8. Revision history**

<b>Date</b>	<b>Revision</b>	<b>Changes</b>
27-May-2004	1	First Release
27-Mar-2006	2	New Temp, few changes

**Please Read Carefully:**

Information in this document is provided solely in connection with ST products. STMicroelectronics NV and its subsidiaries ("ST") reserve the right to make changes, corrections, modifications or improvements, to this document, and the products and services described herein at any time, without notice.

All ST products are sold pursuant to ST's terms and conditions of sale.

Purchasers are solely responsible for the choice, selection and use of the ST products and services described herein, and ST assumes no liability whatsoever relating to the choice, selection or use of the ST products and services described herein.

No license, express or implied, by estoppel or otherwise, to any intellectual property rights is granted under this document. If any part of this document refers to any third party products or services it shall not be deemed a license grant by ST for the use of such third party products or services, or any intellectual property contained therein or considered as a warranty covering the use in any manner whatsoever of such third party products or services or any intellectual property contained therein.

**UNLESS OTHERWISE SET FORTH IN ST'S TERMS AND CONDITIONS OF SALE ST DISCLAIMS ANY EXPRESS OR IMPLIED WARRANTY WITH RESPECT TO THE USE AND/OR SALE OF ST PRODUCTS INCLUDING WITHOUT LIMITATION IMPLIED WARRANTIES OF MERCHANTABILITY, FITNESS FOR A PARTICULAR PURPOSE (AND THEIR EQUIVALENTS UNDER THE LAWS OF ANY JURISDICTION), OR INFRINGEMENT OF ANY PATENT, COPYRIGHT OR OTHER INTELLECTUAL PROPERTY RIGHT.**

**UNLESS EXPRESSLY APPROVED IN WRITING BY AN AUTHORIZED REPRESENTATIVE OF ST, ST PRODUCTS ARE NOT DESIGNED, AUTHORIZED OR WARRANTED FOR USE IN MILITARY, AIR CRAFT, SPACE, LIFE SAVING, OR LIFE SUSTAINING APPLICATIONS, NOR IN PRODUCTS OR SYSTEMS, WHERE FAILURE OR MALFUNCTION MAY RESULT IN PERSONAL INJURY, DEATH, OR SEVERE PROPERTY OR ENVIRONMENTAL DAMAGE.**

Resale of ST products with provisions different from the statements and/or technical features set forth in this document shall immediately void any warranty granted by ST for the ST product or service described herein and shall not create or extend in any manner whatsoever, any liability of ST.

ST and the ST logo are trademarks or registered trademarks of ST in various countries.

Information in this document supersedes and replaces all information previously supplied.

The ST logo is a registered trademark of STMicroelectronics. All other names are the property of their respective owners.

© 2006 STMicroelectronics - All rights reserved



STMicroelectronics group of companies

Australia - Belgium - Brazil - Canada - China - Czech Republic - Finland - France - Germany - Hong Kong - India - Israel - Italy - Japan - Malaysia - Malta - Morocco - Singapore - Spain - Sweden - Switzerland - United Kingdom - United States of America

[www.st.com](http://www.st.com)

## Looking for pricing, stock, or lifecycle information?

Click below to explore more details on WIN SOURCE:

-  [View STM86312 on WIN SOURCE](#)
-  [STMicroelectronics Information](#)

## Optimize Your Supply Chain with WIN SOURCE Solutions

-  Global Sourcing Solution
-  Obsolete Management
-  Cost Control Management
-  Shortage Management
-  Alternative Solution
-  Excess Inventory Management