



**THE DATASHEET OF  
SN54S283J**





# SN54283, SN54LS283, SN54S283, SN74283, SN74LS283, SN74S283 4-BIT BINARY FULL ADDERS WITH FAST CARRY

SDLS095A - OCTOBER 1976 - REVISED MARCH 1988

## logic symbol†

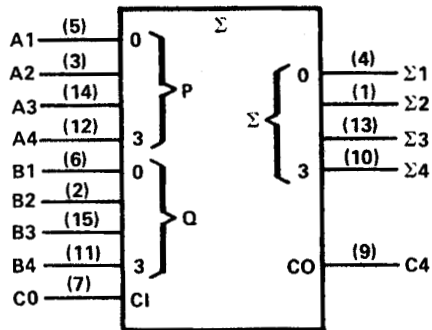

†This symbol is in accordance with ANSI/IEEE Std. 91-1984 and IEC Publication 617-12.

Pin numbers shown are for D, J, N, and W packages.

## logic diagram (positive logic)

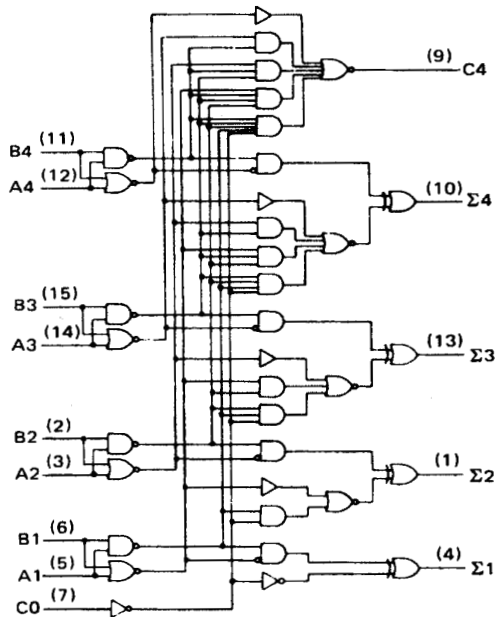

Pin numbers shown are for D, J, N, and W packages.

## schematics of inputs and outputs '283

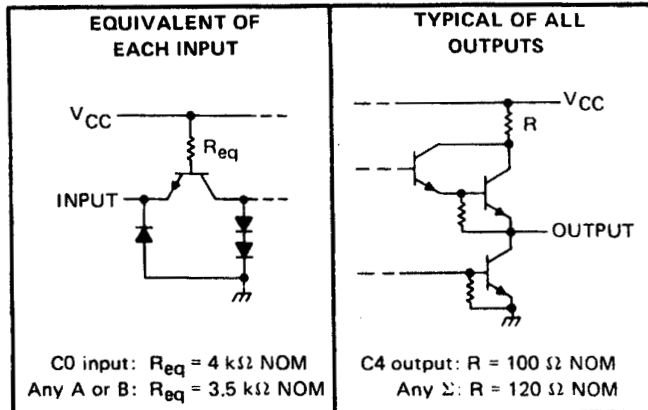

## 'LS283

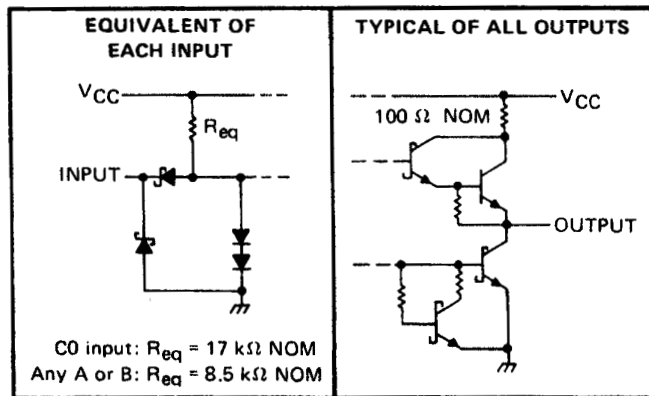

## 'S283

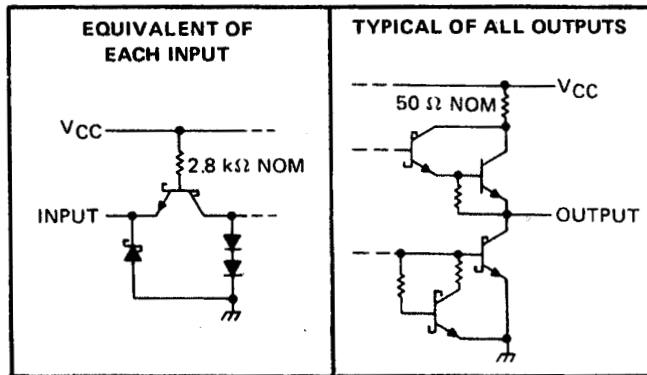

## absolute maximum ratings over operating free-air temperature (unless otherwise noted)

Supply voltage, $V_{CC}$ (see Note 1)	7V
Input voltage: '283, 'S283	5.5V
'LS283	7V
Interemitter voltage (see Note 2)	5.5V
Operating free-air temperature range: SN54283, SN54LS283, SN54S283	-55°C to 125°C
SN74283, SN74LS283, SN74S283	0°C to 70°C
Storage temperature range	-65°C to 150°C

NOTES: 1. Voltage values, except interemitter voltage, are with respect to network ground terminal.

2. This is the voltage between two emitters of a multiple-emitter transistor. This rating applies for the '283 and 'S283 only between the following pairs: A1 and B1, A2 and B2, A3 and B3, A4 and B4.

# SN54283, SN74283

## 4-BIT BINARY FULL ADDERS WITH FAST CARRY

SDLS095A - OCTOBER 1976 - REVISED MARCH 1988

### recommended operating conditions

		SN54283			SN74283			UNIT
		MIN	NOM	MAX	MIN	NOM	MAX	
Supply Voltage, $V_{CC}$		4.5	5	5.5	4.75	5	5.25	V
High-level output current, $I_{OH}$	Any output except C4	-800			-800			$\mu$ A
	Output C4	-400			-400			
Low-level output current, $I_{OL}$	Any output except C4	16			16			mA
	Output C4	8			8			
Operating free-air temperature, $T_A$		-55	125		0	70		$^{\circ}$ C

### electrical characteristics over recommended operating free-air temperature range (unless otherwise noted)

PARAMETER		TEST CONDITIONS <sup>†</sup>	SN54283			SN74283			UNIT	
			MIN	TYP <sup>‡</sup>	MAX	MIN	TYP <sup>‡</sup>	MAX		
$V_{IH}$	High-level input voltage		2			2			V	
$V_{IL}$	Low-level input voltage		0.8			0.8			V	
$V_{IK}$	Input clamp voltage	$V_{CC} = \text{MIN}$ , $I_I = -12 \text{ mA}$	-1.5			-1.5			V	
$V_{OH}$	High-level output voltage	$V_{CC} = \text{MIN}$ , $V_{IH} = 2 \text{ V}$ , $V_{IL} = 0.8 \text{ V}$ , $I_{OH} = \text{MAX}$	2.4	3.6		2.4	3.6		V	
$V_{OL}$	Low-level output voltage	$V_{CC} = \text{MIN}$ , $V_{IH} = 2 \text{ V}$ , $V_{IL} = 0.8 \text{ V}$ , $I_{OL} = \text{MAX}$		0.2	0.4		0.2	0.4	V	
$I_I$	Input current at maximum input voltage	$V_{CC} = \text{MAX}$ , $V_I = 5.5 \text{ V}$	1			1			mA	
$I_{IH}$	High-level input current	$V_{CC} = \text{MAX}$ , $V_I = 2.4 \text{ V}$	40			40			$\mu$ A	
$I_{IL}$	Low-level input current	$V_{CC} = \text{MAX}$ , $V_I = 0.4 \text{ V}$	-1.6			-1.6			mA	
$I_{OS}$	Short-circuit output current $\S$	Any output except C4	$V_{CC} = \text{MAX}$			-20	-55	-18	-55	mA
		Output C4	$V_{CC} = \text{MAX}$			-20	-70	-18	-70	
$I_{CC}$	Supply current	$V_{CC} = \text{MAX}$ , Outputs open	All B low, other inputs at 4.5 V		56		56		mA	
			All inputs at 4.5 V		66	99	66	110		

<sup>†</sup> For conditions shown as MIN or MAX, use the appropriate value specified under recommended operating conditions.

<sup>‡</sup> All typical values are at  $V_{CC} = 5 \text{ V}$ ,  $T_A = 25^{\circ}\text{C}$ .

$\S$  Only one output should be shorted at a time.

### switching characteristics, $V_{CC} = 5 \text{ V}$ , $T_A = 25^{\circ}\text{C}$

PARAMETER <sup>¶</sup>	FROM (INPUT)	TO (OUTPUT)	TEST CONDITIONS	MIN	TYP	MAX	UNIT
$t_{PLH}$	C0	Any $\Sigma$	$C_L = 15 \text{ pF}$ , $R_L = 400 \Omega$ , See Note 3	14	21	ns	
$t_{PHL}$				12	21		
$t_{PLH}$	$A_i$ or $B_i$	$\Sigma_i$		16	24	ns	
$t_{PHL}$				16	24		
$t_{PLH}$	C0	C4	$C_L = 15 \text{ pF}$ , $R_L = 780 \Omega$ , See Note 3	9	14	ns	
$t_{PHL}$				11	16		
$t_{PLH}$	$A_i$ or $B_i$	C4		9	14	ns	
$t_{PHL}$				11	16		

<sup>¶</sup>  $t_{PLH}$  = propagation delay time, low-to-high-level output

$t_{PHL}$  = propagation delay time, high-to-low-level output

NOTE 3: Load circuits and voltage waveforms are shown in Section 1.



# SN54LS283, SN74LS283

## 4-BIT BINARY FULL ADDERS WITH FAST CARRY

SDLS095A – OCTOBER 1976 – REVISED MARCH 1988

### recommended operating conditions

	SN54LS283			SN74LS283			UNIT
	MIN	NOM	MAX	MIN	NOM	MAX	
Supply voltage, $V_{CC}$	4.5	5	5.5	4.75	5	5.25	V
High-level output current, $I_{OH}$			-400			-400	$\mu$ A
Low-level output current, $I_{OL}$			4			8	mA
Operating free-air temperature, $T_A$	-55		125	0		70	$^{\circ}$ C

### electrical characteristics over recommended operating free-air temperature range (unless otherwise noted)

PARAMETER		TEST CONDITIONS <sup>†</sup>	SN54LS283			SN74LS283			UNIT		
			MIN	TYP <sup>‡</sup>	MAX	MIN	TYP <sup>‡</sup>	MAX			
$V_{IH}$	High-level input voltage		2			2			V		
$V_{IL}$	Low-level input voltage				0.7			0.8	V		
$V_{IK}$	Input clamp voltage	$V_{CC} = \text{MIN}, I_I = -18 \text{ mA}$			-1.5			-1.5	V		
$V_{OH}$	High-level output voltage	$V_{CC} = \text{MIN}, V_{IH} = 2 \text{ V}, V_{IL} = V_{IL \text{ max}}, I_{OH} = -400 \mu\text{A}$	2.5	3.4		2.7	3.4		V		
$V_{OL}$	Low-level output voltage	$V_{CC} = \text{MIN}, V_{IH} = 2 \text{ V}, V_{IL} = V_{IL \text{ max}}$	$I_{OL} = 4 \text{ mA}$		0.25	0.4	$I_{OL} = 4 \text{ mA}$		0.25	0.4	V
			$I_{OL} = 8 \text{ mA}$				$I_{OL} = 8 \text{ mA}$		0.35	0.5	
$I_I$	Input current at maximum input voltage	Any A or B	$V_{CC} = \text{MAX}, V_I = 7 \text{ V}$		0.2		0.2		mA		
		C0									
$I_{IH}$	High-level input current	Any A or B	$V_{CC} = \text{MAX}, V_I = 2.7 \text{ V}$		40		40		$\mu$ A		
		C0									
$I_{IL}$	Low-level input current	Any A or B	$V_{CC} = \text{MAX}, V_I = 0.4 \text{ V}$		-0.8		-0.8		mA		
		C0									
$I_{OS}$	Short-circuit output current <sup>§</sup>	$V_{CC} = \text{MAX}$	-20	-100	-20	-100			mA		
$I_{CC}$	Supply current	$V_{CC} = \text{MAX},$ Outputs open	All inputs grounded		22	39	22	39	mA		
			All B low, other inputs at 4.5 V		19	34	19	34			
			All inputs at 4.5 V		19	34	19	34			

<sup>†</sup> For conditions shown as MIN or MAX, use the appropriate value specified under recommended operating conditions.

<sup>‡</sup> All typical values are at  $V_{CC} = 5 \text{ V}, T_A = 25^{\circ} \text{ C}$ .

<sup>§</sup> Only one output should be shorted at a time and duration of the short-circuit should not exceed one second.

### switching characteristics, $V_{CC} = 5 \text{ V}, T_A = 25^{\circ} \text{ C}$

PARAMETER <sup>¶</sup>	FROM (INPUT)	TO (OUTPUT)	TEST CONDITIONS		MIN	TYP	MAX	UNIT
$t_{PLH}$	C0	Any $\Sigma$	$C_L = 15 \text{ pF},$ See Note 3	$R_L = 2 \text{ k}\Omega,$	16	24	ns	
$t_{PHL}$					15	24		
$t_{PLH}$	$A_i$ or $B_i$	$\Sigma_j$			15	24	ns	
$t_{PHL}$					15	24		
$t_{PLH}$	C0	C4			11	17	ns	
$t_{PHL}$					11	22		
$t_{PLH}$	$A_i$ or $B_i$	C4			11	17	ns	
$t_{PHL}$					12	17		

<sup>¶</sup>  $t_{PLH}$  = propagation delay time, low-to-high-level output

$t_{PHL}$  = propagation delay time, high-to-low-level output

NOTE 3: Load circuits and voltage waveforms are shown in Section 1.



# SN54S283, SN74S283 4-BIT BINARY FULL ADDERS WITH FAST CARRY

SDLS095A - OCTOBER 1976 - REVISED MARCH 1988

## recommended operating conditions

		SN54S283			SN74S283			UNIT	
		MIN	NOM	MAX	MIN	NOM	MAX		
Supply voltage, $V_{CC}$		4.5	5	5.5	4.75	5	5.25	V	
High-level output current, $I_{OH}$	Any output except C4	-1			-1			mA	
	Output C4	-500			-500			$\mu$ A	
Low-level output current, $I_{OL}$	Any output except C4	20			20			mA	
	Output C4	10			10				
Operating free-air temperature, $T_A$		-55			0			70	$^{\circ}$ C

## electrical characteristics over recommended operating free-air temperature range (unless otherwise noted)

PARAMETER		TEST CONDITIONS <sup>†</sup>	MIN	TYP <sup>‡</sup>	MAX	UNIT	
$V_{IH}$	High-level input voltage		2			V	
$V_{IL}$	Low-level input voltage				0.8	V	
$V_{IK}$	Input clamp voltage	$V_{CC} = \text{MIN}$ , $I_I = -18 \text{ mA}$			-1.2	V	
$V_{OH}$	High-level output voltage	SN54S283 $V_{CC} = \text{MIN}$ , $V_{IH} = 2 \text{ V}$ ,	2.5	3.4		V	
		SN74S283 $V_{IL} = 0.8 \text{ V}$ , $I_{OH} = \text{MAX}$	2.7	3.4			
$V_{OL}$	Low-level output voltage	$V_{CC} = \text{MIN}$ , $V_{IH} = 2 \text{ V}$ , $V_{IL} = 0.8 \text{ V}$ , $I_{OL} = \text{MAX}$			0.5	V	
$I_I$	Input current at maximum input voltage	$V_{CC} = \text{MAX}$ , $V_I = 5.5 \text{ V}$			1	mA	
$I_{IH}$	High-level input current	$V_{CC} = \text{MAX}$ , $V_I = 2.7 \text{ V}$			50	$\mu$ A	
$I_{IL}$	Low-level input current	$V_{CC} = \text{MAX}$ , $V_I = 0.5 \text{ V}$			-2	mA	
$I_{OS}$	Short-circuit output current <sup>§</sup>	Any output except C4 Output C4	$V_{CC} = \text{MAX}$		-40	-100	mA
					-20	-100	
$I_{CC}$	Supply current	$V_{CC} = \text{MAX}$ , Outputs open	All B low, other inputs at 4.5 V		80		mA
			All inputs at 4.5 V		95	160	

<sup>†</sup>For conditions shown as MIN or MAX, use the appropriate value specified under recommended operating conditions for the applicable device type.

<sup>‡</sup>All typical values are at  $V_{CC} = 5 \text{ V}$ ,  $T_A = 25^{\circ}\text{C}$ .

<sup>§</sup>Only one output should be shorted at a time, and duration of the short-circuit should not exceed one second.

## switching characteristics, $V_{CC} = 5 \text{ V}$ , $T_A = 25^{\circ}\text{C}$

PARAMETER <sup>†</sup>	FROM (INPUT)	TO (OUTPUT)	TEST CONDITIONS	MIN	TYP	MAX	UNIT
$t_{PLH}$	C0	Any $\Sigma$	$C_L = 15 \text{ pF}$ , $R_L = 280 \Omega$ , See Note 3		11	18	ns
$t_{PHL}$					12	18	
$t_{PLH}$	$A_i$ or $B_i$	$\Sigma_i$			12	18	ns
$t_{PHL}$					11.5	18	
$t_{PLH}$	C0	C4	$C_L = 15 \text{ pF}$ , $R_L = 560 \Omega$ , See Note 3		6	11	ns
$t_{PHL}$					7.5	11	
$t_{PLH}$	$A_i$ or $B_i$	C4			7.5	12	ns
$t_{PHL}$					8.5	12	

<sup>†</sup> $t_{PLH}$  = propagation delay time, low-to-high-level output

$t_{PHL}$  = propagation delay time, high-to-low-level output

NOTE 3: Load circuits and voltage waveforms are shown in Section 1.



**PACKAGING INFORMATION**

Orderable Device	Status (1)	Package Type	Package Drawing	Pins	Package Qty	Eco Plan (2)	Lead finish/ Ball material (6)	MSL Peak Temp (3)	Op Temp (°C)	Device Marking (4/5)	Samples
5962-7604301VEA	ACTIVE	CDIP	J	16	25	Non-RoHS & Green	SNPB	N / A for Pkg Type	-55 to 125	5962-7604301VE A SNV54LS283J	<a href="#">Samples</a>
76043012A	ACTIVE	LCCC	FK	20	55	Non-RoHS & Green	SNPB	N / A for Pkg Type	-55 to 125	76043012A SNJ54LS 283FK	<a href="#">Samples</a>
7604301EA	ACTIVE	CDIP	J	16	25	Non-RoHS & Green	SNPB	N / A for Pkg Type	-55 to 125	7604301EA SNJ54LS283J	<a href="#">Samples</a>
7604301FA	ACTIVE	CFP	W	16	25	Non-RoHS & Green	SNPB	N / A for Pkg Type	-55 to 125	7604301FA SNJ54LS283W	<a href="#">Samples</a>
JM38510/31202BEA	ACTIVE	CDIP	J	16	25	Non-RoHS & Green	SNPB	N / A for Pkg Type	-55 to 125	JM38510/ 31202BEA	<a href="#">Samples</a>
JM38510/31202BFA	ACTIVE	CFP	W	16	25	Non-RoHS & Green	SNPB	N / A for Pkg Type	-55 to 125	JM38510/ 31202BFA	<a href="#">Samples</a>
M38510/31202BEA	ACTIVE	CDIP	J	16	25	Non-RoHS & Green	SNPB	N / A for Pkg Type	-55 to 125	JM38510/ 31202BEA	<a href="#">Samples</a>
M38510/31202BFA	ACTIVE	CFP	W	16	25	Non-RoHS & Green	SNPB	N / A for Pkg Type	-55 to 125	JM38510/ 31202BFA	<a href="#">Samples</a>
SN54LS283J	ACTIVE	CDIP	J	16	25	Non-RoHS & Green	SNPB	N / A for Pkg Type	-55 to 125	SN54LS283J	<a href="#">Samples</a>
SN54S283J	ACTIVE	CDIP	J	16	25	Non-RoHS & Green	SNPB	N / A for Pkg Type	-55 to 125	SN54S283J	<a href="#">Samples</a>
SN74LS283D	ACTIVE	SOIC	D	16	40	RoHS & Green	NIPDAU	Level-1-260C-UNLIM	0 to 70	LS283	<a href="#">Samples</a>
SN74LS283N	ACTIVE	PDIP	N	16	25	RoHS & Green	NIPDAU	N / A for Pkg Type	0 to 70	SN74LS283N	<a href="#">Samples</a>
SN74LS283NE4	ACTIVE	PDIP	N	16	25	RoHS & Green	NIPDAU	N / A for Pkg Type	0 to 70	SN74LS283N	<a href="#">Samples</a>
SN74LS283NSR	ACTIVE	SO	NS	16	2000	RoHS & Green	NIPDAU	Level-1-260C-UNLIM	0 to 70	74LS283	<a href="#">Samples</a>
SN74S283N	ACTIVE	PDIP	N	16	25	RoHS & Green	NIPDAU	N / A for Pkg Type	0 to 70	SN74S283N	<a href="#">Samples</a>
SNJ54LS283FK	ACTIVE	LCCC	FK	20	55	Non-RoHS & Green	SNPB	N / A for Pkg Type	-55 to 125	76043012A SNJ54LS 283FK	<a href="#">Samples</a>

Orderable Device	Status (1)	Package Type	Package Drawing	Pins	Package Qty	Eco Plan (2)	Lead finish/ Ball material (6)	MSL Peak Temp (3)	Op Temp (°C)	Device Marking (4/5)	Samples
SNJ54LS283J	ACTIVE	CDIP	J	16	25	Non-RoHS & Green	SNPB	N / A for Pkg Type	-55 to 125	7604301EA SNJ54LS283J	<a href="#">Samples</a>
SNJ54LS283W	ACTIVE	CFP	W	16	25	Non-RoHS & Green	SNPB	N / A for Pkg Type	-55 to 125	7604301FA SNJ54LS283W	<a href="#">Samples</a>
SNJ54S283J	ACTIVE	CDIP	J	16	25	Non-RoHS & Non-Green	SNPB	N / A for Pkg Type	-55 to 125	SNJ54S283J	<a href="#">Samples</a>

(1) The marketing status values are defined as follows:

**ACTIVE:** Product device recommended for new designs.

**LIFEBUY:** TI has announced that the device will be discontinued, and a lifetime-buy period is in effect.

**NRND:** Not recommended for new designs. Device is in production to support existing customers, but TI does not recommend using this part in a new design.

**PREVIEW:** Device has been announced but is not in production. Samples may or may not be available.

**OBSOLETE:** TI has discontinued the production of the device.

(2) **RoHS:** TI defines "RoHS" to mean semiconductor products that are compliant with the current EU RoHS requirements for all 10 RoHS substances, including the requirement that RoHS substance do not exceed 0.1% by weight in homogeneous materials. Where designed to be soldered at high temperatures, "RoHS" products are suitable for use in specified lead-free processes. TI may reference these types of products as "Pb-Free".

**RoHS Exempt:** TI defines "RoHS Exempt" to mean products that contain lead but are compliant with EU RoHS pursuant to a specific EU RoHS exemption.

**Green:** TI defines "Green" to mean the content of Chlorine (Cl) and Bromine (Br) based flame retardants meet JS709B low halogen requirements of <=1000ppm threshold. Antimony trioxide based flame retardants must also meet the <=1000ppm threshold requirement.

(3) MSL, Peak Temp. - The Moisture Sensitivity Level rating according to the JEDEC industry standard classifications, and peak solder temperature.

(4) There may be additional marking, which relates to the logo, the lot trace code information, or the environmental category on the device.

(5) Multiple Device Markings will be inside parentheses. Only one Device Marking contained in parentheses and separated by a "~" will appear on a device. If a line is indented then it is a continuation of the previous line and the two combined represent the entire Device Marking for that device.

(6) Lead finish/Ball material - Orderable Devices may have multiple material finish options. Finish options are separated by a vertical ruled line. Lead finish/Ball material values may wrap to two lines if the finish value exceeds the maximum column width.

**Important Information and Disclaimer:**The information provided on this page represents TI's knowledge and belief as of the date that it is provided. TI bases its knowledge and belief on information provided by third parties, and makes no representation or warranty as to the accuracy of such information. Efforts are underway to better integrate information from third parties. TI has taken and continues to take reasonable steps to provide representative and accurate information but may not have conducted destructive testing or chemical analysis on incoming materials and chemicals. TI and TI suppliers consider certain information to be proprietary, and thus CAS numbers and other limited information may not be available for release.

In no event shall TI's liability arising out of such information exceed the total purchase price of the TI part(s) at issue in this document sold by TI to Customer on an annual basis.

**OTHER QUALIFIED VERSIONS OF SN54LS283, SN54LS283-SP, SN54S283, SN74LS283, SN74S283 :**

- Catalog : [SN74LS283](#), [SN54LS283](#), [SN74S283](#)
- Military : [SN54LS283](#), [SN54S283](#)
- Space : [SN54LS283-SP](#)

## NOTE: Qualified Version Definitions:

- Catalog - TI's standard catalog product
- Military - QML certified for Military and Defense Applications
- Space - Radiation tolerant, ceramic packaging and qualified for use in Space-based application

**TAPE AND REEL INFORMATION**

**QUADRANT ASSIGNMENTS FOR PIN 1 ORIENTATION IN TAPE**



\*All dimensions are nominal

Device	Package Type	Package Drawing	Pins	SPQ	Reel Diameter (mm)	Reel Width W1 (mm)	A0 (mm)	B0 (mm)	K0 (mm)	P1 (mm)	W (mm)	Pin1 Quadrant
SN74LS283NSR	SO	NS	16	2000	330.0	16.4	8.2	10.5	2.5	12.0	16.0	Q1

**TAPE AND REEL BOX DIMENSIONS**

\*All dimensions are nominal

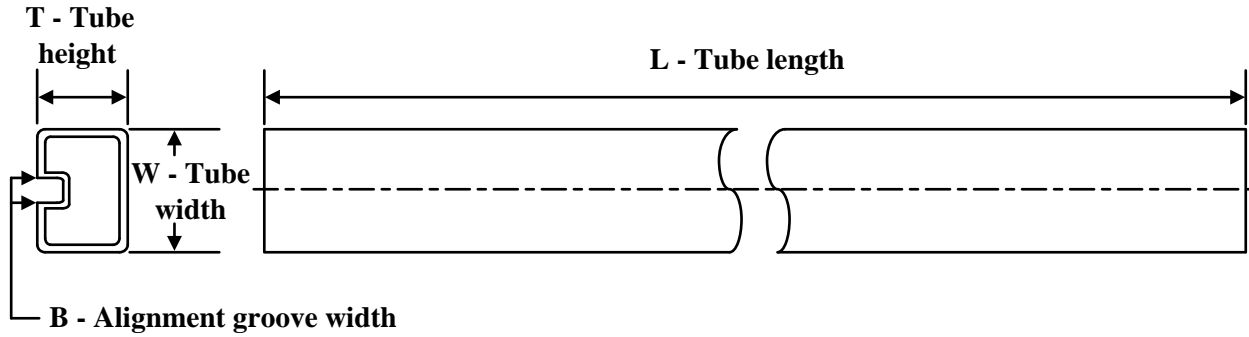
Device	Package Type	Package Drawing	Pins	SPQ	Length (mm)	Width (mm)	Height (mm)
SN74LS283NSR	SO	NS	16	2000	356.0	356.0	35.0

**TUBE**

\*All dimensions are nominal

Device	Package Name	Package Type	Pins	SPQ	L (mm)	W (mm)	T (μm)	B (mm)
76043012A	FK	LCCC	20	55	506.98	12.06	2030	NA
7604301FA	W	CFP	16	25	506.98	26.16	6220	NA
JM38510/31202BFA	W	CFP	16	25	506.98	26.16	6220	NA
M38510/31202BFA	W	CFP	16	25	506.98	26.16	6220	NA
SN74LS283D	D	SOIC	16	40	507	8	3940	4.32
SN74LS283N	N	PDIP	16	25	506	13.97	11230	4.32
SN74LS283N	N	PDIP	16	25	506	13.97	11230	4.32
SN74LS283NE4	N	PDIP	16	25	506	13.97	11230	4.32
SN74LS283NE4	N	PDIP	16	25	506	13.97	11230	4.32
SN74S283N	N	PDIP	16	25	506	13.97	11230	4.32
SN74S283N	N	PDIP	16	25	506	13.97	11230	4.32
SNJ54LS283FK	FK	LCCC	20	55	506.98	12.06	2030	NA
SNJ54LS283W	W	CFP	16	25	506.98	26.16	6220	NA

## IMPORTANT NOTICE AND DISCLAIMER

TI PROVIDES TECHNICAL AND RELIABILITY DATA (INCLUDING DATA SHEETS), DESIGN RESOURCES (INCLUDING REFERENCE DESIGNS), APPLICATION OR OTHER DESIGN ADVICE, WEB TOOLS, SAFETY INFORMATION, AND OTHER RESOURCES "AS IS" AND WITH ALL FAULTS, AND DISCLAIMS ALL WARRANTIES, EXPRESS AND IMPLIED, INCLUDING WITHOUT LIMITATION ANY IMPLIED WARRANTIES OF MERCHANTABILITY, FITNESS FOR A PARTICULAR PURPOSE OR NON-INFRINGEMENT OF THIRD PARTY INTELLECTUAL PROPERTY RIGHTS.

These resources are intended for skilled developers designing with TI products. You are solely responsible for (1) selecting the appropriate TI products for your application, (2) designing, validating and testing your application, and (3) ensuring your application meets applicable standards, and any other safety, security, regulatory or other requirements.

These resources are subject to change without notice. TI grants you permission to use these resources only for development of an application that uses the TI products described in the resource. Other reproduction and display of these resources is prohibited. No license is granted to any other TI intellectual property right or to any third party intellectual property right. TI disclaims responsibility for, and you will fully indemnify TI and its representatives against, any claims, damages, costs, losses, and liabilities arising out of your use of these resources.

TI's products are provided subject to [TI's Terms of Sale](#) or other applicable terms available either on [ti.com](https://www.ti.com) or provided in conjunction with such TI products. TI's provision of these resources does not expand or otherwise alter TI's applicable warranties or warranty disclaimers for TI products.

TI objects to and rejects any additional or different terms you may have proposed.

Mailing Address: Texas Instruments, Post Office Box 655303, Dallas, Texas 75265  
Copyright © 2024, Texas Instruments Incorporated

## Looking for pricing, stock, or lifecycle information?

Click below to explore more details on WIN SOURCE:

 [View SN54S283J on WIN SOURCE](#)

 [Texas Instruments](#) Information

## Optimize Your Supply Chain with WIN SOURCE Solutions

-  Global Sourcing Solution
-  Obsolete Management
-  Cost Control Management
-  Shortage Management
-  Alternative Solution
-  Excess Inventory Management